



Compact Refrigerators & Freezers

Service and Installation Manual

Please read this manual completely before attempting to install or operate this equipment! **Notify carrier of damage!** Inspect all components immediately.



400 & 4000 Series

Work-Top And Undercounter Refrigerator Or Freezer Bases



Important Information
Read Before Use
Please Save These Instructions!

February 2013



Important Warning And Safety Information



WARNING

Read This Manual Thoroughly Before Operating, Installing, Or Performing Maintenance On The Equipment.



WARNING

Failure To Follow Instructions In This Manual Can Cause Property Damage, Injury Or Death.



WARNING

Do Not Store Or Use Gasoline Or Other Flammable Vapors Or Liquids In The Vicinity Of This Or Any Other Appliance.



WARNING

Unless All Cover And Access Panels Are In Place And Properly Secured, Do Not Operate This Equipment.



WARNING

This Appliance Is Not Intended For Use By Persons Who Lack Experience Or Knowledge, Unless They Have Been Given Supervision Or Instruction Concerning Use Of The Appliance By A Person Responsible For Their Safety.



WARNING

This Appliance Is Not To Be Played With.



WARNING

Do Not Clean With Water Jet.



WARNING

Do Not Use Electrical Appliances Inside The Food Storage Compartment Of This Appliance.



CAUTION

Observe the following:

- Minimum clearances must be maintained from all walls and combustible materials.
- Keep the equipment area free and clear of combustible material.
- Allow adequate clearance for air openings.
- Operate equipment only on the type of electricity indicated on the specification plate.
- Unplug the unit before making any repairs.
- Retain this manual for future reference.

Contents

Receiving & Inspecting Equipment.....	3
Serial Number Location	4
Warranty Information.....	4
Regulatory Certifications.....	4
Specifications.....	5
Installation	6
Caster Or Leg Installation	7
Caster & Leg Mounting Detail.....	7
Refrigerator Temperature Control Operation.....	8
Freezer Model 4148 Temperature Control Operation	8
Freezer Models 403 & 407 Temperature Control Operation.....	9
Evaporator Fan Operation	9
Maintenance.....	10-11
Refrigerator Wiring Diagram.....	12
Refrigerator Replacement Parts Lists	12
Freezer Wiring Diagram	13
Freezer Replacement Parts Lists.....	13
Standard Labor Guidelines.....	14
Notes	15

Receiving And Inspecting The Equipment

Even though most equipment is shipped crated, care should be taken during unloading so the equipment is not damaged while being moved into the building.

1. Visually inspect the exterior of the package and skid or container. Any damage should be noted and reported to the delivering carrier immediately.
2. If damaged, open and inspect the contents with the carrier.
3. In the event that the exterior is not damaged, yet upon opening, there is concealed damage to the equipment notify the carrier. Notification should be made verbally as well as in written form.
4. Request an inspection by the shipping company of the damaged equipment. This should be done within 10 days from receipt of the equipment.
5. Check the lower portion of the unit to be sure legs or casters are not bent.
6. Be sure to check the compressor compartment housing and visually inspect the refrigeration package. Be sure lines are secure and base is still intact.
7. Freight carriers can supply the necessary damage forms upon request.
8. Retain all crating material until an inspection has been made or waived.

Serial Number Location

The serial number on 400 series compact refrigerators and freezers is printed on the right side of the interior back wall.

The serial tag on 4000 series compact refrigerators and freezers is located either on the left upper sidewall inside the cabinet or under the top nosing directly above the door when the door is in the closed position (right hand door when there are two doors).

Always have the serial number of your unit available when calling for parts or service. A complete list of authorized Delfield parts depots is on www.delfield.com.

This manual covers standard units only. If you have a custom unit, consult the customer service department at 1-800-733-8829

©2013 The Delfield Company. All rights reserved. Reproduction without written permission is prohibited.

"Delfield" is a registered trademark of The Delfield Company.

Warranty Information

Visit http://www.delfield.com/minisite/service/warranty_info to:

- Register your product for warranty.
- Verify warranty information.
- View and download a copy of your warranty.

Regulatory Certifications

Models are certified by:



National Sanitation Foundation (NSF)



Underwriters Laboratories (UL)

Underwriters Laboratories of Canada (ULC)

Specifications

Work Top Refrigerator Bases With Stainless Steel Top & Backsplash

<i>Model</i>	<i>L</i>	<i>D</i>	<i>H</i>	<i>Volume Ft.³</i>	<i>Shelves Ft.²</i>	<i>H.P.</i>	<i>Refrg. Charge</i>	<i>Amp</i>	<i>NEMA Plug</i>	<i>Ship Weight</i>
402	27" (68.6cm)	28.5" (72.4cm)	39.5" (100.3cm)	5.7	4.6	1/5	7.0	4.0	5-15P	176lbs (80kg)
ST4048	48" (121.9cm)	28.5" (72.4cm)	39.5" (100.3cm)	10.80	8.0	1/5	7.0	4.0	5-15P	234lbs (106kg)

Undercounter Refrigerator Bases With Stainless Steel Top

<i>Model</i>	<i>L</i>	<i>D</i>	<i>H</i>	<i>Volume Ft.³</i>	<i>Shelves Ft.²</i>	<i>H.P.</i>	<i>Refrg. Charge</i>	<i>Amp</i>	<i>NEMA Plug</i>	<i>Ship Weight</i>
406	27" (68.6cm)	28.5" (72.4cm)	35.5" (90.2cm)	5.7	4.6	1/5	7.0	4.0	5-15P	176lbs (80kg)
UC4048	48" (121.9cm)	28.5" (72.4cm)	35.5" (90.2cm)	10.80	8.0	1/5	7.0	4.0	5-15P	236lbs (107kg)

Undercounter Refrigerator With Subtop And 3.75" Casters

<i>Model</i>	<i>L</i>	<i>D</i>	<i>H</i>	<i>Volume Ft.³</i>	<i>Shelves Ft.²</i>	<i>H.P.</i>	<i>Refrg. Charge</i>	<i>Amp</i>	<i>NEMA Plug</i>	<i>Ship Weight</i>
406-CA	27" (68.6cm)	27.75" (70.5cm)	33.25" (84.5cm)	5.7	4.6	1/5	7.0	4.0	5-15P	168lbs (76kg)

Work Top Freezer Bases With Stainless Steel Top & Backsplash

<i>Model</i>	<i>L</i>	<i>D</i>	<i>H</i>	<i>Volume Ft.³</i>	<i>Shelves Ft.²</i>	<i>H.P.</i>	<i>Refrg. Charge</i>	<i>Amp</i>	<i>NEMA Plug</i>	<i>Ship Weight</i>
403	27" (68.6cm)	28.5" (72.4cm)	39.5" (100.3cm)	5.7	4.6	1/5	7.0	5.8	5-15P	184lbs (83kg)
ST4148	48" (121.9cm)	28.5" (72.4cm)	39.5" (100.3cm)	10.80	8.0	1/3	7.0	5.6	5-15P	242lbs (110kg)

Undercounter Freezer Bases With Stainless Steel Top

<i>Model</i>	<i>L</i>	<i>D</i>	<i>H</i>	<i>Volume Ft.³</i>	<i>Shelves Ft.²</i>	<i>H.P.</i>	<i>Refrg. Charge</i>	<i>Amp</i>	<i>NEMA Plug</i>	<i>Ship Weight</i>
407	27" (68.6cm)	28.5" (72.4cm)	35.5" (90.2cm)	5.7	4.6	1/5	7.0	5.8	5-15P	176lbs (80kg)
UC4148	48" (121.9cm)	28.5" (72.4cm)	35.5" (90.2cm)	10.80	8.0	1/3	7.0	5.6	5-15P	236lbs (107kg)

Undercounter Freezer With Subtop And 3.75" Casters

<i>Model</i>	<i>L</i>	<i>D</i>	<i>H</i>	<i>Volume Ft.³</i>	<i>Shelves Ft.²</i>	<i>H.P.</i>	<i>Refrg. Charge</i>	<i>Amp</i>	<i>NEMA Plug</i>	<i>Ship Weight</i>
407-CA	27" (68.6cm)	27.75" (70.5cm)	33.25" (84.5cm)	5.7	4.6	1/5	7.0	5.8	5-15P	168lbs (76kg)



Installation

Location

Units represented in this manual are intended for indoor use only. Be sure the location chosen has a floor strong enough to support the total weight of the cabinet and contents. Reinforce the floor as necessary to provide for maximum loading.

For the most efficient refrigeration, be sure to provide good air circulation inside and out.

Inside cabinet: Do not pack refrigerator so full that air cannot circulate.

Outside cabinet: Be sure that the unit has access to ample air. On all 400 and 4000 Series equipment a minimum space of 3" (7.6cm) at the back of the unit and 1" (2.5cm) at the top and sides is required to conform to Underwriters Laboratories' standards. On undercounter units it is imperative that the proper air flow be maintained. The refrigeration system is designed so air will flow under the unit, over the compressor/condenser area, and out at the top rear of the unit. Avoid hot corners and locations near stoves and ovens.



Any restriction of the proper air flow outlined above, total or partial, will void the warranty on the unit.

Leveling

A level cabinet will perform better because the drain pan will drain properly, the doors will line up with the frames and the cabinet will not be subject to undue strain.

All four legs are adjustable. Adjust each leg until the unit is stable and level left to right. If necessary adjusting the front legs slightly higher than the rear by about 1/8" (0.3cm) will help the door remain closed.

If the unit is supplied with casters, no adjustments are available. Ensure the floor where the unit is to be located is level.



Never stand on the unit! Doing so may result in bodily injury. They are not designed to hold the weight of an adult and will collapse if misused in this manner.

Stabilizing

Some models are supplied on casters for your convenience, for ease of cleaning underneath and mobility.



The unit must be installed in a stable condition with the front wheels locked. Locking the front casters after installation is the owner's responsibility.

Plumbing

Self-contained models are standard with a condensate evaporator. If, for some reason, a unit does not have a condensate evaporator, or the evaporator fails, the unit's drain must have an outlet to an appropriate drainage area or container.



Moisture collecting from improper drainage can create a slippery surface on the floor and a hazard to employees. It is the owner's responsibility to provide a container or outlet for drainage.

Electrical connection

Refer to the amperage data on the specifications page, the serial tag, your local code or the National Electrical Code to be sure the unit is connected to the proper power source. A protected circuit of the correct voltage and amperage must be run for connection of the line cord, or permanent connection to the unit.

A 6' (1.8 m) long grounded supply cord and plug are provided with standard units. Simply plug the unit in to begin operation.



The thermostat must be turned to OFF and the unit disconnected from the power source whenever performing service, maintenance functions or cleaning the refrigerated area.

Stacked 400 series electrical connection

Models 406 and 407 may be stacked using a stacking collar, Delfield model 409. In this case two 6' (1.8m) long grounded supply cords and plugs are standard. Simply plug them in to begin operation.



For Cord Connected Units - Risk of Electric Shock. This equipment has two power supply cords. Unplug all cords before moving or servicing this equipment.

Caster Or Leg Installation - 400 & 4000 Series

1. Carefully place the unit on its back (see illustration at right).
2. Located at each caster mounting location are 4 Phillips head screws, for a total of 16 screws. Remove them.
3. Place a locking plate caster or leg over one of the front holes, matching the 4 mounting holes to the pre-drilled holes in the underside of the unit. Insert 4 Phillips head screws and tighten. Repeat with the other locking front caster or leg.
4. Repeat step 3 with the non-locking casters or legs in the rear of the unit.
5. Carefully lift the unit upright.

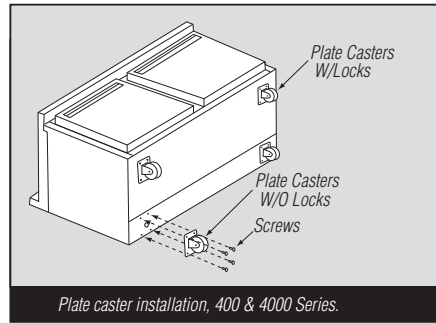

WARNING  After installing casters or legs, the unit must stand upright for twenty-four (24) hours before being powered up to assure oil return to the compressor sump.

2", 3" and 5" Caster and Leg Mounting Detail

A universal bolt hole pattern is provided on the bottom of the cabinet. It will accommodate any leg or caster. Simply line up the plate holes with the corresponding cabinet holes.

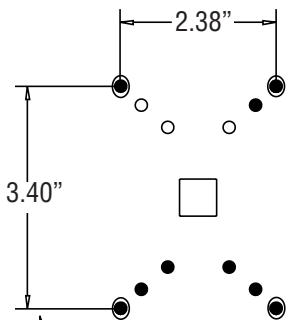

NOTE:

If hole pattern on caster/leg matches the one above mount in outer set of holes.

6" Leg - [3234569](#)

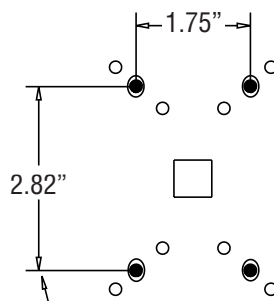

NOTE:

If hole pattern on caster/leg matches the one above mount in middle set of holes.

3" Caster - [3234024](#)
5" Caster - [3234161](#)

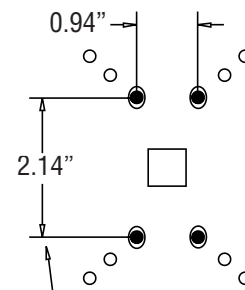

NOTE:

If hole pattern on caster/leg matches the one above mount in inner set of holes.

2" Caster - [3234148](#)

Refrigerator Temperature Control Operation

After the unit is connected to power it will automatically begin operating. With the doors closed, the temperature of the cabinet should reach 36°F to 40°F (2°C to 4°C) on refrigerators in about one hour.

A thermostat located in the evaporator housing on interior rear of the unit, controls the temperature in the box. The factory setting for the control is “4” and maintains about 38°F (3°C) in the box. Set toward “1” for higher temperatures and toward “7” for lower temperatures.

Continuous opening and closing of the doors will hamper the unit’s ability to maintain optimum refrigeration temperature.

Refrigerators defrost automatically with every cycle of the

compressor. The water generated is routed to a pan on the rear of the unit and is evaporated by the heat given off by the compressor.



Turn the defrost timer screw ONLY in a clockwise direction, turning the screw counter-clockwise will break the cam motor.

Service Alert

During normal operation the evaporator fan may cycle and/or pulse independently of the compressor. Consult the service manual or contact Technical Support at 1-800-733-8829 if you are unsure of the proper function.

Freezer Model 4148 Temperature Control Operation

After the unit is connected to power it will automatically begin operating. With the doors closed, the temperature of the cabinet should reach 0°F (-18°C) on freezers in about one hour.

A thermostat located in the evaporator housing on interior rear of the unit, controls the temperature in the box. The factory setting for the control is “4” and maintains about -3°F (-18°C) in the box. Set toward “1” for higher temperatures and toward “7” for lower temperatures.

Continuous opening and closing of the doors will hamper the unit’s ability to maintain optimum refrigeration temperature.

When the mechanical timer initiates a defrost cycle, power to the condensing unit and evaporator fans is interrupted and the defrost heater is energized. The defrost heater warms the

evaporator coil thereby melting all frost accumulated during the previous refrigeration cycle. Once all frost is eliminated, the temperature of the coil continues to rise until it reaches 27 minutes. The defrost control switches to refrigeration mode. Defrost will initiate every six hours.



Turn the defrost timer screw ONLY in a clockwise direction, turning the screw counter-clockwise will break the cam motor.

Service Alert

During normal operation the evaporator fan may cycle and/or pulse independently of the compressor. Consult the service manual or contact Technical Support at 1-800-733-8829 if you are unsure of the proper function.

Freezer Models 403 & 407 Temperature Control Operation

After the unit is connected to power it will automatically begin operating. With the doors closed, the temperature of the cabinet should reach 0°F (-18°C) on freezers in about one hour. Continuous opening and closing of the doors will hamper the unit's ability to maintain optimum temperature.

The electronic temperature control constantly monitors box temperature as well as evaporator coil temperature to maintain consistent product temperatures. As an added energy-saving feature, the electronic controller will switch the evaporator fan motor on and off with the compressor and condenser fan motor.

At initial start-up or anytime power is disconnected, then reconnected to the unit, the control will delay all operations for a short time (up to 10 minutes.) While in this delay period, the control initializes the control parameters and confirms that the temperature sensors and circuits are operational.

Service Alert: During normal operation the evaporator fan may cycle and/or pulse independently of the compressor. Consult the service manual or contact Technical Support at 1-800-733-8829 if you are unsure of the proper function.

IMPORTANT NOTE REGARDING FREEZERS:

After initializing, the control will immediately enter a DEFROST mode. The compressor and condenser fan as well as the evaporator fan will remain off until initial defrost is complete. This initial defrost cycle may take up to 15 minutes to complete, at which time the freezing cycle will begin.

Whenever the freezer is plugged in, and the control has completed initializing including the initial defrost cycle (see above), the electronic temperature control will cycle the compressor, evaporator fan motor, and condenser fan motor to maintain box temperature at the control setting.

Freezer Automatic Defrost

The control also monitors compressor total running time and will enter a defrost cycle after total compressor running time is greater than 5-hours since the last defrost cycle OR if evaporator coil temperature drops below -34°F (indicating excessive frost on the coil).

Freezer Manual Defrost

If a manual defrost is desired, simply unplug the unit for several seconds, then plug unit back in. This will cause the control to re-initialize and then enter a defrost cycle.

When the control enters the defrost mode, whether manual or automatic, it switches off the evaporator fan motor, compressor and condenser fan motor, and switches on the defrost heater to warm the evaporator coil and melt all frost accumulated during the previous refrigeration cycle. The control will continue the defrost cycle for a MINIMUM of 8 minutes and a MAXIMUM of 30 minutes depending on the amount of frost accumulated on the evaporator coil.

After the defrost cycle is complete, the control returns to a normal refrigeration cycle, however the evaporator fan motor will not switch on for 2 minutes AFTER the compressor and condenser fan motor have begun operating.

Electronic Temperature Control Location & Adjustment

Never turn the knob more than 1 dial number and always allow 8 hours for temperature stabilization before making any additional adjustments. The control is located in the control box at the rear of the unit (see photo). It is factory set at mid-range to maintain about -3°F (-18°C) box temperature. To adjust for colder temperatures, turn the knob clockwise. For warmer temperatures, turn the knob counter-clockwise. Turn the knob fully counter-clockwise to turn the refrigeration system off.

Evaporator Fan Operation

		Cooling Cycle				Defrost Cycle	
		Compressor On		Compressor Off		Compressor Off	
		Evap Fan On	Evap Fan Off	Evap Fan On	Evap Fan Off	Evap Fan On	Evap Fan Off
400	Refrigerator	X		X		X	
400	Freezer	X			X		X
4000	Refrigerator	X		X		X	
4000	Freezer	X		X			X

Maintenance



The thermostat must be turned to OFF and the unit disconnected from the power source whenever performing service, maintenance functions or cleaning the refrigerated area.

Refrigerators and Freezers

The interior and exterior can be cleaned using soap and warm water. If this isn't sufficient, try ammonia and water or a nonabrasive liquid cleaner. When cleaning the exterior, always rub with the "grain" of the stainless steel to avoid marring the finish.

Do not use an abrasive cleaner because it will scratch the stainless steel and plastic and can damage the breaker strips and gaskets.

Cleaning the Condenser Coil

The condenser coil requires regular cleaning, recommended is every 90 days. In some instances though you may find that there is a large amount of debris and dust or grease accumulated prior to the 90 day time frame. In these cases the condenser coil should be cleaned every 30 days.

If the build up on the coil consists of only light dust and debris the condenser coil can be cleaned with a simple brush, heavier dust build up may require a vacuum or even compressed air to blow through the condenser coil.

If heavy grease is present there are de-greasing agents available for refrigeration use and specifically for the condenser coils. The condenser coil may require a spray with the de-greasing agent and then blown through with compressed air.

Failure to maintain a clean condenser coil can initially cause high temperatures and excessive run times, continuous operation with dirty or clogged condenser coils can result in compressor failures. Neglecting the condenser coil cleaning procedures will void any warranties associated with the compressor or cost to replace the compressor.



Never use a high pressure water wash for this cleaning procedure as water can damage the electrical components located near or at the condenser coil.

In order to maintain proper refrigeration performance, the condenser fins must be cleaned of dust, dirt and grease regularly. It is recommended that this be done at least every three months. If conditions are such that the condenser is totally blocked in three months, the frequency of cleaning should be increased. Clean the condenser with a vacuum cleaner or stiff brush. If extremely dirty, a commercially available condenser cleaner may be required.

Stainless Steel Care and Cleaning

To prevent discoloration or rust on stainless steel several important steps need to be taken. First, we need to understand the properties of stainless steel. Stainless steel contains 70-80% iron which will rust. It also contains 12-30% chromium which forms an invisible passive film over the steel's surface which acts as a shield against corrosion. As long as the protective layer is intact, the metal is still stainless. If the film is broken or contaminated, outside elements can begin to breakdown the steel and begin to form rust or discoloration.

Proper cleaning of stainless steel requires soft cloths or plastic scouring pads.



NEVER USE STEEL PADS, WIRE BRUSHES OR SCRAPERS!

Cleaning solutions need to be alkaline based or non-chloride cleaners. Any cleaner containing chlorides will damage the protective film of the stainless steel. Chlorides are also commonly found in hard water, salts, and household and industrial cleaners. If cleaners containing chlorides are used be sure to rinse repeatedly and dry thoroughly upon completion.

Routine cleaning of stainless steel can be done with soap and water. Extreme stains or grease should be cleaned with a non-abrasive cleaner and plastic scrub pad. It is always good to rub with the grain of the steel. There are also stainless steel cleaners available which can restore and preserve the finish of the steel's protective layer.

Early signs of stainless steel breakdown can consist of small pits and cracks. If this has begun, clean thoroughly and start to apply stainless steel cleaners in attempt to restore the passivity of the steel.



Never use an acid based cleaning solution! Many food products have an acidic content which can deteriorate the finish. Be sure to clean the stainless steel surfaces of ALL food products. Common items include, tomatoes, peppers and other vegetables.

If your freezer seems to vibrate excessively when the compressor is running, loosen (but do not remove) the bolts on the compressor. Semi hermetic models should be loosened before operating.

Gasket Maintenance

Gaskets require regular cleaning to prevent mold and mildew build up and also to keep the elasticity of the gasket. Gasket cleaning can be done with the use of warm soapy water. Avoid full strength cleaning products on gaskets as this can cause

Maintenance, continued

them to become brittle and prevent proper seals. Also, never use sharp tools or knives to scrape or clean the gasket which could possibly tear the gasket and rip the bellows.

Gaskets can easily be replaced and do not require the use of tools or authorized service persons. The gaskets are "Dart" style and can be pulled out of the groove in the door and new gaskets can be "pressed" back into place.

Doors/Hinges

Over time and with heavy use doors the hinges may become loose. If it is noticed that the door is beginning to sag, it may become necessary to tighten the screws that mount the hinge brackets to the frame of the unit. If the doors are loose or sagging this can cause the hinge to pull out of the frame which may damage both the doors and the door hinges. In some cases this can require qualified service agents or maintenance personnel.

If it becomes necessary to adjust a door, follow these instructions:

1. If the door needs lowering at the handle, use a 5/16" wrench to loosen the hinge screws and install a spacer outside of the hinge (see illustration 1). Tighten the screws.
2. If the door needs to be higher at the handle, use a 5/16" wrench to loosen the hinge screws and install a spacer inside of the hinge (see illustration 2). Tighten the screws.

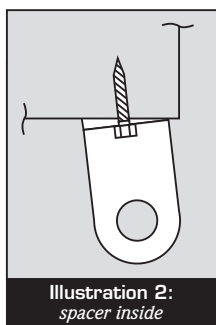
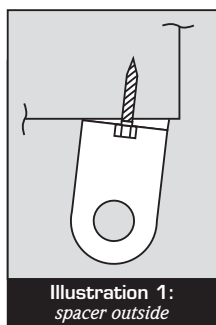

Drain Maintenance

Each unit has a drain located inside the unit which removes the condensation from the evaporator coil and evaporates it at an external condensate evaporator pan. Each drain can become loose or disconnected from moving or bumping the drain. If you notice excessive water accumulation on the inside of the unit be sure the drain tube is connected from the evaporator housing to the condensate evaporator drain pan. If water is collected underneath the unit you may want to check the condensate evaporator drain tube to be sure it is still located inside the drain pan. The leveling of the unit is important as the units are designed to drain properly when on a level surface, if your floor is not level this can also cause drain problems. Be sure all drain lines are free of obstructions, typically food product is found blocking drain lines causing water to back up and overflow the drain pans.

Service Alert

During normal operation the evaporator fan may cycle and/or pulse independently of the compressor. Consult the service manual or contact Technical Support at 1-800-733-8829 if you are unsure of the proper function.

Refrigerator Wiring Diagram - 400 and 4000 Series

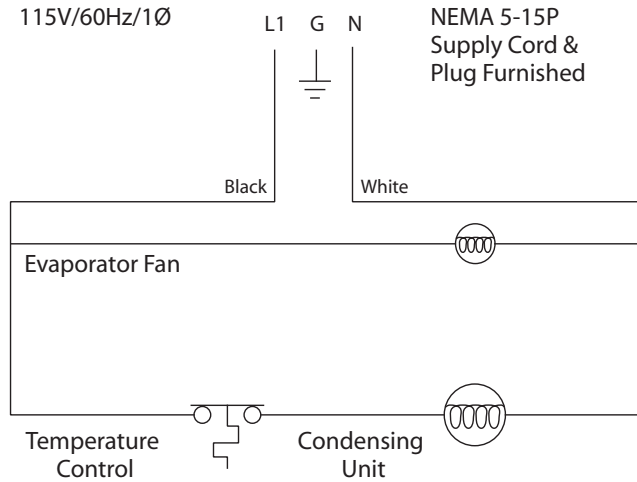

Refrigerator Replacement Parts List

402/406/406CA

Part #	Description
3234025	3" Caster, brake
3234024	3" Caster, no brake
3234160	5" Caster, no brake
3234161	5" Caster, brake
3234791	6" Leg
000-B3I-0031	27" Door, left hand
000-B3I-0030	27" Door, right hand
0074057	Capillary tube (.044 id x 144")
3526997	Compressor
3516446	Compressor relay
2194787	Compressor start capacitor
158-ATA-0050	Condensate coil, hot gas
149-AWM-0040	Condensate pan
3516275	Condenser coil
3516172	Condenser fan blade, clear lexan
2162691	Condenser fan motor
1702623	Door gasket
3516116	Evaporator coil
3516172	Evaporator fan blade, clear lexan
2162691	Evaporator fan motor
3516321	Filter drier
3237569	Hinge, Btm LT, McDonalds
3237563	Hinge, Btm RT, McDonalds
3237516	Hinge, Cartridge, McDonalds
3237568	Hinge, Top LT, McDonalds
3237562	Hinge, Top RT, McDonalds
0420067	Hinge kit (left or right hinged)
3978271	Shelf
3235014	Shelf clip
2194759KT	Temp control (control, knob, and dial plate)
2194761	Temperature control knob

ST4048/UC4048

Part #	Description
3234025	3" Caster, brake
3234024	3" Caster, no brake
3234160	5" Caster, no brake
3234161	5" Caster, brake
3234791	6" Leg
000-B3I-0035	24" Door, left hand
000-B3I-0034	24" Door, right hand
0074057	Capillary tube (.044 id x 144")
3526997	Compressor
3516446	Compressor relay
2194787	Compressor start capacitor
158-ATA-0050	Condensate coil, hot gas
149-AWM-0040	Condensate pan
3516275	Condenser coil
3516172	Condenser fan blade, clear lexan
3516173	Condenser fan guard
2162691	Condenser fan motor
1702622	Door gasket
3516116	Evaporator coil
3516172	Evaporator fan blade, clear lexan
3516173	Evaporator fan guard
2162691	Evaporator fan motor
3516321	Filter drier
0420067	Hinge kit (left or right hinged)
3978272	Shelf
2194759KT	Temp control (control, knob and dial plate)
2194761	Temperature control knob

Freezer Wiring Diagrams - 400 and 4100 Series

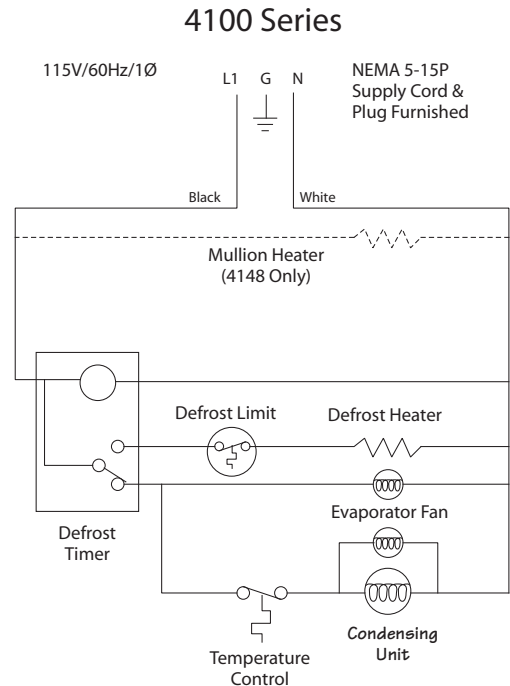
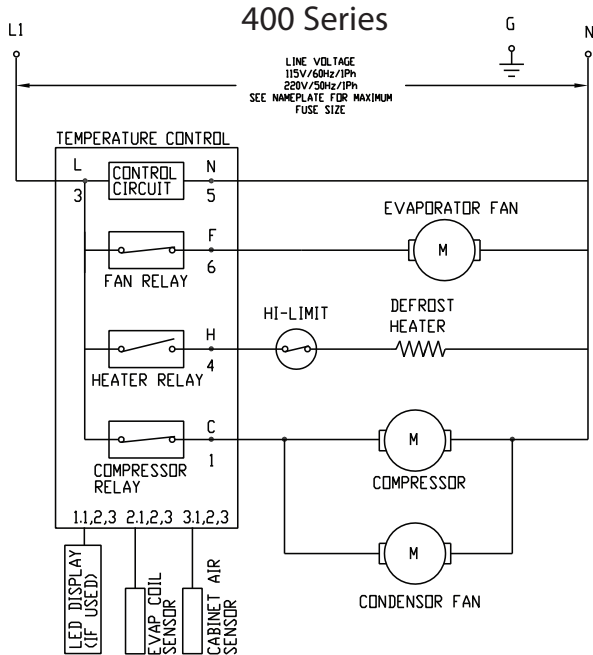

Freezer Replacement Parts List

403/407/407CA

Part #	Description
3234025	3" Caster, brake
3234024	3" Caster, no brake
3234160	5" Caster, no brake
3234161	5" Caster, brake
3234791	6" Leg
000-B31-0031	27" Door, left hand
000-B31-0030	27" Door, right hand
0074058	Capillary tube (.036 id x 168")
3526996	Compressor
3516446	Compressor relay
2194787	Compressor start capacitor
158-ATA-0050	Condensate coil, hot gas
149-AWM-0040	Condensate pan
3516275	Condenser coil
3516172	Condenser fan blade, clear lexan
3516173	Condenser fan guard
2162715	Condenser fan motor
2194774	Defrost heater
1702623	Door gasket
3516418	Evaporator Coil
3516172	Evaporator fan blade, clear lexan
3516173	Evaporator fan guard
2162691	Evaporator fan motor
3516321	Filter Drier
3978055	Heater guard, 18"
0420067	Hinge kit (left or right hinged)
3978271	Shelf
3235014	Shelf clip
2194817KT	Temp. control kit, electronic, w/sensors
9294472	Wiring Diagram

ST4148/UC4148

Part #	Description
3234025	3" Caster, brake
3234024	3" Caster, no brake
3234160	5" Caster, no brake
3234161	5" Caster, brake
000-B31-0035	24" Door, left hand
000-B31-0034	24" Door, right hand
3234791	6" Leg
0074058	Capillary tube (.036 id x 168")
3527000	Compressor
158-ATA-0050	Condensate coil, hot gas
149-AWM-0040	Condensate pan
3516276	Condenser coil
3516172	Condenser fan blade, clear lexan
2162715	Condenser fan motor
2194774	Defrost heater
3516156	Defrost timer
1702622	Door gasket
3516418	Evaporator coil
3517356	Evaporator fan blade, black
3516173	Evaporator fan guard
2162715	Evaporator fan motor
3516321	Filter drier
3978055	Heater guard, 18"
0420067	Hinge kit (left or right hinged)
3978272	Shelf
3517400	Thermostat, Mechanical, Freezer

Standard Labor Guidelines To Repair Or Replace Parts On Delfield Equipment

Advice and recommendations given by Delfield Service Technicians do not constitute or guarantee any special coverage.

- A maximum of 1-hour is allowed to **diagnose a defective component**.
- A maximum of 1-hour is allowed for **retrieval of parts** not in stock.
- A maximum **travel distance** of 100 miles round trip and 2-hours will be reimbursed.
- Overtime, installation/start-up, normal control adjustments, general maintenance, glass breakage, freight damage, and/or correcting and end-user installation error will not be reimbursed under warranty unless pre-approved with a **Service Work Authorization** from Delfield. You must submit the number with the service claim.

Labor Of 1-Hour Is Allowed To Replace:

- Thermostat
- Infinite Switch
- Door Jam Switch
- Solenoid Coil
- Hi-limit/Thermal Protector Switch
- Fan Delay/Defrost Termination Switch
- Compressor Start Components and Overload Protector
- Defrost Timer
- Thermometer
- Gear Box
- Contractor/Relay
- Transformer
- Evaporator/Condenser Fan Motor and Blade
- Circulating Fan Motor and Blade
- Microprocessor Control
- Water Level Sensor/Probe
- Door Hinges, Locks, and Gaskets
- Condensate Element
- Springs/Lowerator

Labor Of 2 Hours To Replace:

- Defrost Element
- Heating Element
- Locate/Repair Leak
- Pressure Control
- Solenoid Valve

Labor Of 3 Hours To Replace:

- EPR or CPR Valve
- Expansion Valve
- Condenser or Evaporator Coil

Labor Of 4 Hours To Replace:

- Compressor

This includes recovery of refrigerant and leak check.

\$55.00 maximum reimbursement for refrigerant recovery (includes recovery machine, pump, torch, oil, flux, minor fittings, solder, brazing rod, nitrogen, or similar fees.)

Refrigerants:

- R22 A maximum of \$4.00/lb. or 25¢/oz. will be reimbursed.
- R134A A maximum of \$5.00/lb. or 31¢/oz. will be reimbursed.
- R404A A maximum of \$15.00/lb. or \$1.00/oz. will be reimbursed.

Notes





Mt. Pleasant, MI



Covington, TN

Thank you for choosing Delfield!

Help is a phone call away. Help our team of professional, courteous customer service reps by having your model number and serial number available at the time of your call (800) 733-8829.

Model: _____ S/N: _____

Installation Date: _____



For a list of Delfield's authorized parts depots, visit our website at www.delfield.com

Register your Delfield warranty online. Go to www.delfield.com under the service tab to complete.

