

Aladdin®

Aladdin Synergetics, Inc.
Nashville, TN 37214
1-800-888-8018

R61THKD R62THKD RE THERMALIZATION REFRIGERATORS

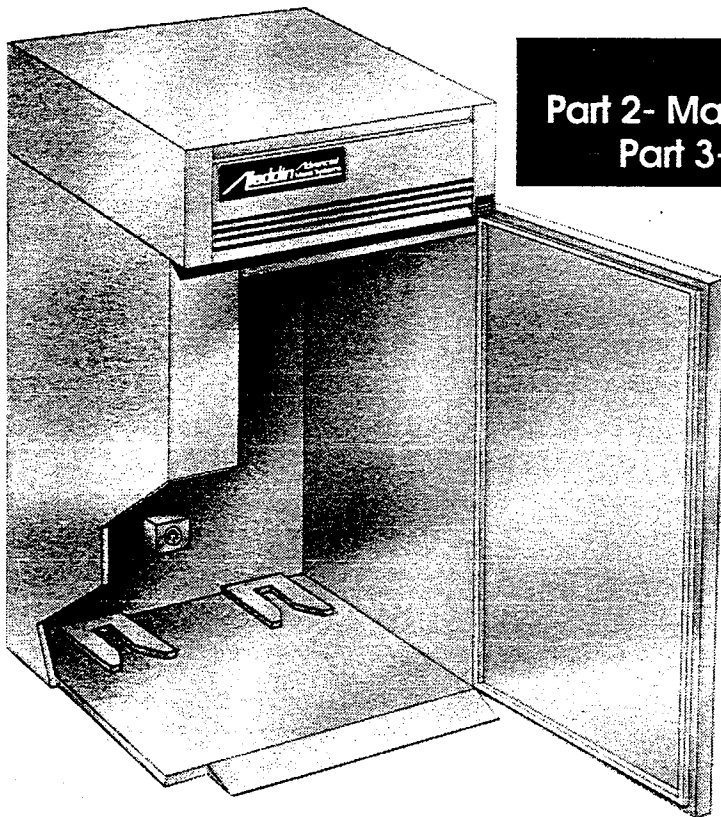

REFRIGERATOR SHOWN
R61THKD

Part 1 - Rethermalization Refrigerators
Part 2 - Magic Touch Controller & Troubleshooting
Part 3 - Drawings, Parts List & Wiring Diagrams

INSTALLATION, OPERATION & MAINTENANCE MANUAL

Manual P/N 75351



Copyright © 1995 Aladdin Synergetics, Inc.

Changes may be made to the information in this document without notification.

RE THERMALIZATION REFRIGERATORS

CONTENTS

PART 1	
R61THKD/R62THKD	5
PART 2	
MAGIC TOUCH CONTROLLER	15
PART 3	
DIAGRAMS, PARTS LIST & WIRING DIAGRAMS.....	29

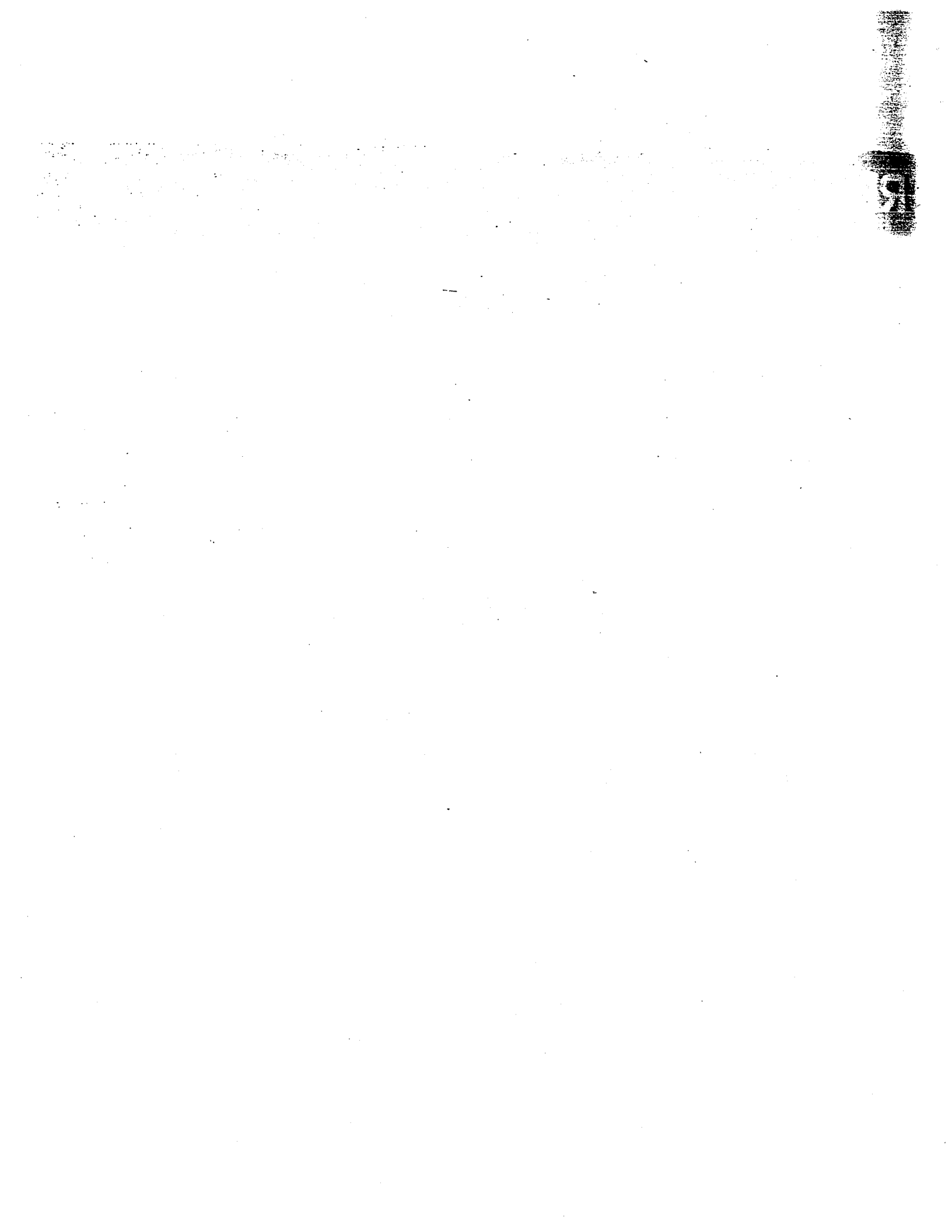

RE THERMALIZATION REFRIGERATORS

PART 1

CONTENTS

I. MODELS	6
II. RECEIVING INSPECTIONS	6
III. STORAGE SUGGESTIONS	7
IV. INSTALLATION	7
V. ELECTRICAL	9
VI. START-UP	10
VII. CLEANING	12
VIII. PREVENTIVE MAINTENANCE	12
IX. SERVICE	13
X. WARRANTY.....	13

RE THERMALIZATION REFRIGERATORS

I. MODELS: R61THKD, Single Bay Unit / R62THKD, Double Bay Unit- Air Cooled

A. Dimensions

Model	Width	Depth ¹	Height ²
R61THKD	40"(101.6cm)	35"(88.9cm)	83-7/8"(213.04cm)
R62THKD	68-1/4"(173.36cm)	35"(88.9cm)	83-7/8"(213.04cm)

B. Dimensions of units without doors, hinges, and front panel.

Model	Width	Depth ¹	Height ²
R61THKD	40"(101.6cm)	32-1/2"(82.6cm)	83-7/8"(213.04cm)
R62THKD	68-1/4"(173.36cm)	32-1/2"(82.6cm)	83-7/8"(213.04cm)

C. Overall Weight

Model	Crated	Uncrated
R61THKD	744 lbs.(338kg)	673 lbs.(305kg)
R62THKD	1,102 lbs.(500kg)	1,019 lbs.(462kg)

D. Electrical

Model	Voltage ³	Cycle	Min. Cir. Ampacity	Max Over Current Protection
R61THKD	120v/208v or 240v	60 Hz	36.39A	45
R62THKD	120v/208v or 240v	60Hz	55.50A	60

E. Refrigeration

Model	Refrigerant	Cond. Unit	Heat Rejected ⁴	Room Temperature Not To Exceed
R61THKD	R404A, 20 oz.	1/2 hp	5544 BTU/HR	90°F (32.2°C)
R62THKD	R404A, 22 oz.	1 hp	11,221 BTU/HR	90°F (32.2°C)

1. Door handle protrudes 1-7/16" beyond 35" depth.
2. A minimum of 12" ceiling clearance above condensing unit is required.
3. Refer to Electrical Section for 240v Service Installation Procedure.
4. Based on 100% Run time at maximum load. The refrigeration systems are designed to run 50% of the time at 90°F, (32.2°C). Ambient temperature.

II. RECEIVING INSPECTIONS

NOTE:

All Aladdin® units are factory tested for performance and certified free from defects.

ALADDIN DAMAGED GOODS POLICY

There are two types of damaged merchandise: A. VISIBLE DAMAGE B. CONCEALED DAMAGE

A. VISIBLE DAMAGE- (The product being received is visibly damaged).

1. The receiver should refuse the damaged merchandise.
2. Receiver should sign packing slip "refused merchandise due to damage" when receiving partial shipment.
3. Contact Aladdin Customer Service Representative and alert them to the situation.

- B. CONCEALED DAMAGE**-(Damaged merchandise cannot be externally detected). Any receiving operation should inspect for this type of damage.

IF PRODUCT IS DAMAGED:

1. Save all packing material.
2. Contact Aladdin Customer Service Representative and alert them to the situation.
3. Receiver must call the carrier to schedule an inspection of the damaged merchandise.

III. STORAGE SUGGESTIONS

IMPORTANT: If possible, store the unit(s) with all packaging intact in a weather proof enclosure. **Do Not** expose the units to extreme high or low temperatures, excessive humidity, or dusty conditions. Store units **UPRIGHT** on a level surface.

IV. INSTALLATION

NOTE: The installation instructions are similar for both the R61THKD single bay unit and the R62THKD double bay unit.

A. LOCATION REQUIREMENTS

1. To ensure optimum performance the top of all units **MUST HAVE A MINIMUM 12" CLEARANCE ABOVE THE UNIT.** The 12" overhead clearance is also necessary to access the unit should servicing be required. (This is required for the front panel to swing up).
THE MINIMUM FINISHED FLOOR TO CEILING HEIGHT REQUIRED FOR PROPER OPERATION OF THE RETHERMALIZATION REFRIGERATORS IS 96".
2. The normal temperature of the room where the rethermalization refrigerators are placed must not exceed 90°F (32.2°C) for the units to operate properly.

B. MOVING THE UNIT THROUGH DOORWAYS

The doors hinges and top fascia should be removed if location doorways are 34" (86.4cm) or narrower.

C. REMOVAL OF DOORS, HARDWARE & TOP FASCIA

CAUTION

1. Each door weighs approximately 72 lbs. (32.7 kg). Utmost care should be taken whenever the door is lifted off its hinges. **ATTENTION:** If more than one unit is being moved, care should be taken when doors are re-installed. **DOORS MUST BE RETURNED TO THE SAME UNIT THEY WERE REMOVED FROM.**
2. The doors on the units feature lift-off self-closing hinges. Open door to a full 180 degrees and lift upward.

RE THERMALIZATION REFRIGERATORS

3. **Removal of the hinges from the cabinet body is not recommended.** If it becomes necessary to remove the hinges, mark hinge location prior to removal from the cabinet to ensure proper door re-alignment.
4. **Removal of top fascia.** If it is necessary to remove the top fascia, disconnect polarized wire connectors from the back of the MAGIC TOUCH CONTROLLER before removing the front lift up panel. Remove the stainless steel fascia from the condensing unit area to reduce overall height of unit. Reassemble fascia and MAGIC TOUCH CONTROLLER.

NOTE: When reconnecting the Magic Touch Controller, **be sure that the 11 pin connector is in the "A" side, not the "D" side.** To check that the connections are correct, press the view button 3 times. If 80 volts is displayed, check connections again.

D. SETTING THE UNIT IN PLACE

1. **ATTENTION:** The unit should remain on its skid during movement to the point of installation to prevent damage to bottom of unit.
2. **CAUTION:** The single unit weighs 673 lbs. (305kg.) and the double unit weighs 1019 lbs. (462kg.) **Extreme Care** must be taken whenever the unit is moved or tilted to remove the skid.
3. **The unit rests on the skid and is not secured by bolts.** The removal from the skid requires several people to slowly slide the unit off the skid. **Avoid tilting the unit when removing it from the skid.** **CAUTION: If it was necessary to tilt the unit during installation, it must not be plugged in for a period of 24 hours after being set in place.**

E. LEVELING

1. Units must be level within 1/8" (3.18mm) to ensure proper door closure. Level installation is critical for the double door units. If problems are encountered when closing the doors, bottom door seal is binding, or door locks are not engaging properly, the unit is most likely not level.
2. If the unit is more than 1/8" (3.18mm) out of level, the unit should be shimmed. The recommended shim material is 12" x 12" (30.5cm) vinyl floor tile.
3. **EXAMPLE:** If the right hand end of the double door unit is about 1/4" (6.35mm) low, due to flooring inconsistencies, use a pry bar to lift the low end, then slide a full tile under that end as far as possible. If necessary, take a second tile to push the piece as far under the unit as possible. Cut off any tile extending outside the cabinet body. Add a second layer and a third, if necessary, until the unit is level. Be sure to trim off any tile projecting out from the sides of the unit. The objective is to support the entire bottom of the refrigerator so that the unit floor will not sag with use.

F. RAMP INSTALLATION

A stainless steel ramp is shipped with the units. The front edge of the refrigerator interior floor has stainless steel shoulder bolts to receive and secure the entry ramp. Simply position the slots on the ramp over the shoulder bolts and lower the ramp into position. This ramp can be easily removed for cleaning by reversing the installation steps.

V. ELECTRICAL

1. ELECTRICAL REQUIREMENTS

R61THKD (single unit): 120/208 or 240v*, 60 Cycle, Single Phase, 45 Amp maximum over current protection.

R62THKD (double unit): 120/208 or 240v*, 60 Cycle, Single Phase, 60 Amp maximum over current protection.

NOTE: The roll-in refrigerators are set-up for 120/208v power supply. If a 240v application is necessary see following

* 240 Volt Service

For 240v service a field wiring change must be performed. **A qualified electrician is required for this modification.** This modification is a one step procedure: A **NEUTRAL** wire must be connected from the panel to the capped **BLACK WIRE w/ blue label** on the boost transformer. Consult wiring diagram for the location of the boost transformer.

NOTE: All factory wiring has been made in compliance with electrical codes and UL requirements.

WARNING: All installation electrical and grounding connections must comply with the applicable portions of the National Electrical Code and/or all local electrical codes. **A qualified electrician should make all required installation connections. Consult wiring diagram provided.**

2. ELECTRICAL CONNECTION

A breaker panel/load center with circuit breakers is provided for field connections. This panel is marked FIELD CONNECTION and should be the only panel entered into for electrical connection during installation.

A separate electrical circuit should be used when installing the roll-in refrigerators. Size wiring to handle the indicated load and provide the necessary over current circuit protection.

REITHERMALIZATION REFRIGERATORS

WARNING: When making electrical connections, it is mandatory that the incoming neutral line be laid down on a neutral bus. If a hot leg is connected to a neutral bus, 208 or 240 volts will be across the 120 volt transformer and will destroy the primary side of the transformer.

RECOMMENDATION: Check the supply voltage prior to connection to be certain the proper voltage for the unit is available. Check the serial nameplate inside unit for correct voltage.

VI. START-UP

1. DEFROST CYCLE

Set the current time on the Paragon clock. Set defrost cycle on Paragon clock for four (4) 20 minute defrost cycles per day. Clock setting instructions are inside the clock cover.

NOTE: Defrost cycles are factory set for 12AM, 2PM, 10PM, and 4AM Central Time. If a defrost time schedule change is required, it can be changed. Follow the instructions located inside the defrost timer cover. **DO NOT SET THE DEFROST TIME DURING SCHEDULED REITHERM CYCLES.**

2. MAGIC TOUCH CONTROLLER BATTERY

A standard 9 Volt battery is provided for the Magic Touch Controller. During shipment, this battery is reversed in the battery harness, so that it will maintain its charge. Prior to operation the battery(s) must be installed correctly for the controller to function.

R61THKD, Single Bay Unit has (1) one 9V. Battery, R62THKD, Double Bay Unit has (2) two 9V. Batteries

3. STARTING UNIT

CAUTION: Before starting the unit, make sure the evaporator fan blades are securely fastened

Lift up the front panel high enough to engage panel support bracket locking mechanism. Turn power circuit breakers on.

4. START-UP CHECKS

Check that the compressor is running and the air circulating fans are also functioning. *The compressor will run for approximately one hour, or until the empty cabinet is cooled to a temperature of 32 °F (0°C).*

NOTE: Wait until cabinet temperature stabilizes between 32-40°F (0-4.4°C) before placing cart(s) loaded with product into the cabinet. Running the unit with the door closed will cause the compressor to cycle and maintain the internal cabinet temperature of 32-40°F (0-4.4°C).

5. ELECTRIC CONDENSATE EVAPORATOR

All units are equipped with electric condensate evaporators. To verify that the condensate evaporator pan is working correctly, feel the exterior side wall. The exterior side wall should feel warm to hot after a 15 minute warm-up period.

6. CLOSE FRONT PANEL

Close front panel by first pushing the panel in an upwards direction to disengage the support bracket lock and carefully lower the panel. Be careful not to let the panel fall and bang into the cabinet.

7. CART PRESENT INDICATOR

Open the refrigerator door(s) and roll cart(s) all the way into the cabinet. Check the Magic Touch Controller to see if the CART PRESENT indicator is highlighted.

Figure 1
Retherm Cart

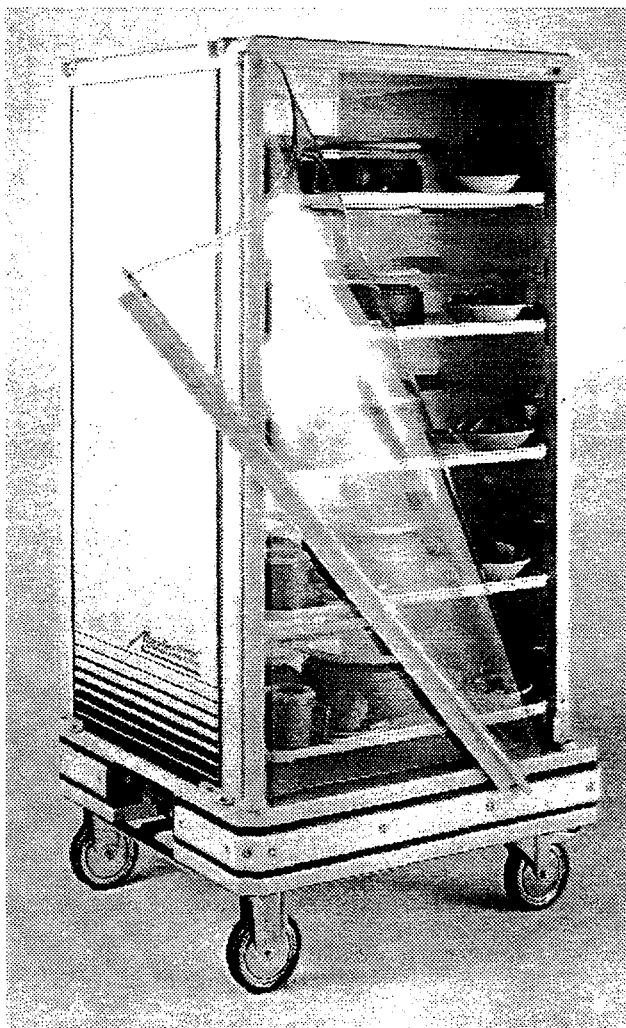

RE THERMALIZATION REFRIGERATORS

VII. CLEANING

1. CABINET - INTERIOR & EXTERIOR

Clean and sanitize the interior and exterior surfaces initially prior to placing a cart loaded with product into the cabinet. Regular cleaning requires only mild soap and water.

NOTE: *Do not use abrasives, harsh chemicals, or chlorine products for cleaning.*

2. CONDENSER COIL

A. Turn off unit

- B. Cleaning of the condenser coil is critical for top performance and efficiency of the Aladdin Rethermalization Refrigerator. Clean coil with a solution of warm soapy water and a soft bristle brush. **DO NOT BEND FINS ON COIL.**

Use a soft cloth to absorb any excess water. Restart unit and allow the interior temperature to return to normal operating range before loading product.

Check the condenser coil for cleanliness weekly and clean as necessary.

VIII. PREVENTIVE MAINTENANCE

BATTERY REPLACEMENT

A standard 9 Volt Battery is provided for the Magic Touch Controller. This battery is easily replaced. On the front of the controller the **LOW BATTERY** indicator will be highlighted when the battery needs to be replaced. Raise the front panel high enough to engage the panel lock. The battery is located on the back of the front panel above the controller. Reach up and grasp the battery and gently pull from right to left until the terminals disengage. Remove the expired battery holder and dispose of properly.

INSTALL THE NEW BATTERY IN REVERSE ORDER, PAYING ATTENTION TO THE BATTERY TERMINAL POLARITY.

NOTE: Replace batteries annually or as needed. **ALWAYS** replace annually as part of a preventive maintenance program.

IX. SERVICE

In the event service is required on your Aladdin Rethermalization Refrigerator Unit, please call
ALADDIN SYNERGETICS, INC., SERVICE DEPARTMENT, 1-800-888-5426

X. WARRANTY

ALADDIN SYNERGETICS, INC. EQUIPMENT LIMITED WARRANTY

Effective July 1, 1995

Aladdin Synergetics, Inc. ("Aladdin") warrants to the original purchaser that the equipment listed below shall be free from defects in material and workmanship under normal use for the applicable warranty term set forth below. Aladdin's obligation under this warranty is limited to the repair or replacement, at the sole option of Aladdin, of any part which upon inspection and examination by Aladdin or its authorized agent is found to be defective. A written description detailing the nature of the claimed defect, together with the equipment claimed to be defective if required by Aladdin, must be delivered to Aladdin or its authorized agent within 30 days of discovery of the claimed defect (but in no event later than 30 days after the expiration of the applicable warranty term).

EQUIPMENT	WARRANTY TERM*		COMPRESSOR WARRANTY TERM** PARTS ONLY***
	PARTS	LABOR	
R61THKD	1 Year	90 Days	5 Years
R62THKD	1 Year	90 Days	5 Years

*The warranty term commences 30 days after Aladdins invoice for the equipment.

**The compressor warranty covers the compressor only and does not include any shipping charges, other transportation costs, any external parts or electrical components, labor, refrigerants and taxes.

THE WARRANTIES AND REPRESENTATIONS OF ALADDIN CONTAINED HEREIN ARE EXPRESSLY IN LIEU OF, AND THE BUYER WAIVES, ANY AND ALL OTHER WARRANTIES EXPRESS OR IMPLIED, INCLUDING THE WARRANTIES OF MERCHANTABILITY AND FITNESS FOR A PARTICULAR PURPOSE, AND ANY OTHER REMEDIES AGAINST ALADDIN, WHETHER BASED UPON CONTRACT, NEGLIGENCE, STRICT LIABILITY OR OTHERWISE. ALADDIN SHALL NOT BE LIABLE FOR ANY CONSEQUENTIAL OR INCIDENTAL DAMAGES OR ECONOMIC LOSS OF ANY NATURE (INCLUDING WITHOUT LIMITATION LOSS OF REVENUES AND/OR PROFITS) THAT MAY BE CLAIMED TO RESULT FROM ANY NEGLIGENCE OR BREACH OF WARRANTY OR CONTRACT BY ALADDIN.

Exceptions and Exclusions

This warranty is issued only to the original purchaser, and is not transferable and applies only to the products installed within the United States of America, its territories and Canada. During the term of any labor warranty, Aladdin will pay all pre-approved shipping charges incurred in returning defective equipment to Aladdin and labor costs incurred in the removal and reinstallation of such equipment. Contact Aladdin before returning any claimed defective equipment or otherwise performing warranty repairs. Aladdin assumes no liability for any work or repair performed without its prior approval. After the expiration of any labor warranty, the original purchaser is responsible for all shipping charges incurred in returning defective equipment to Aladdin and labor for removing and reinstalling such equipment. Aladdin shall not be responsible for the replacement of expendable items like lamps and fuses or product failure resulting from normal wear and tear, improper installation, misuse, sabotage, abuse, neglect, accident, unauthorized alterations or repair, or other factors beyond the control of Aladdin. Neither this warranty nor the liability of Aladdin may be modified or extended by action of any agent, distributor or other person or by custom or practice.

CALL ALADDIN TOLL FREE AT 1-800-888-5426 IF YOU HAVE ANY QUESTIONS ABOUT THIS WARRANTY OR YOUR ALADDIN PRODUCT.

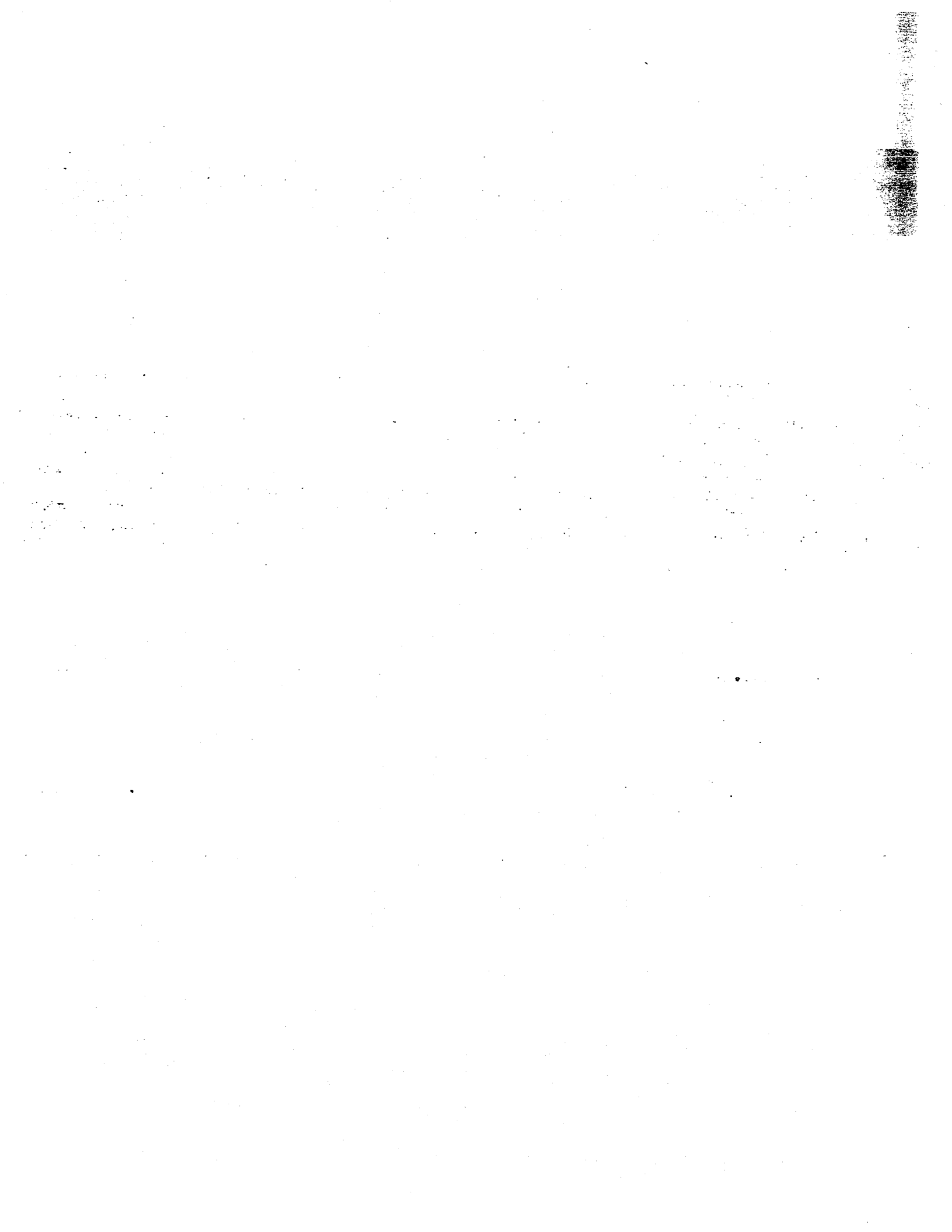

Aladdin®

Aladdin Synergetics, Inc.
Nashville, TN 37214
1-800-888-8018

MAGIC TOUCH CONTROLLER -3

Part 2

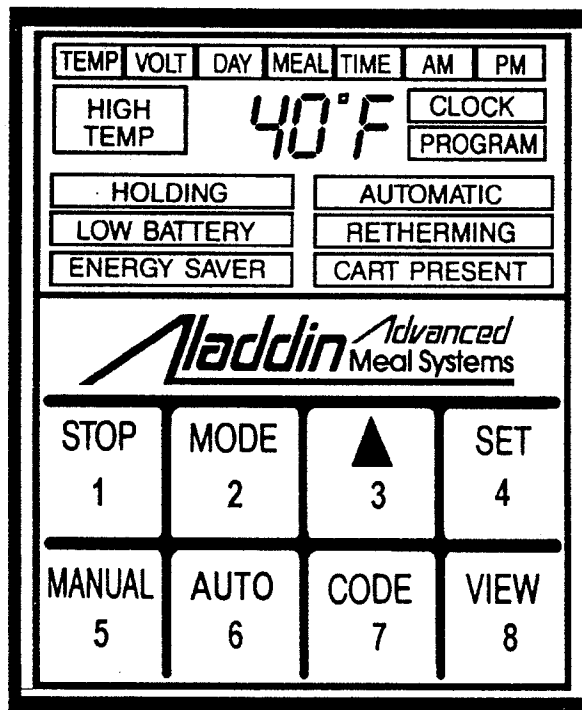

INSTALLATION, OPERATION & MAINTENANCE MANUAL

Manual P/N 39855

MAGIC TOUCH CONTROLLER -3

CONTENTS

I. THE CONTROLLER FACE	16
II. The View Mode	16
III. Programming Controller	16
A. Security Level 2	16
B. Programming Meal Times	17
C. Setting 12 Hour AM/PM Clock	18
D. Energy Saver	19
E. Retherm Cycle Countdown	20
F. High Temp/High Temp Time	20
G. Temperature Display	21
H. Holding Cycle	21
I. Changing Security Codes	22
J. Leaving Security Level 2	23
IV. Cart Present Indicator	23
V. Starting a Retherm Cycle Manually	23
VI. Stopping a Retherm Cycle	24
VII. Placing Controller in Automatic Mode	24
VIII. Getting Out of Automatic Mode	25
IX. Low Battery Indicator	25
X. Set Clock Indicator	26
XI. Compensation of Low Voltage	26
XII. Other Controller Features	26

Part III

Troubleshooting Tips & Service.....27

NOTE: When programming the Magic Touch Controller, all button sequences must be done in intervals of less than ten seconds

II. The View Mode



The **VIEW** button can be pressed successively to display the following in the controller window:

1. Refrigerator Cabinet Temperature
2. Time of Day
3. Available Voltage

I. The Controller Face

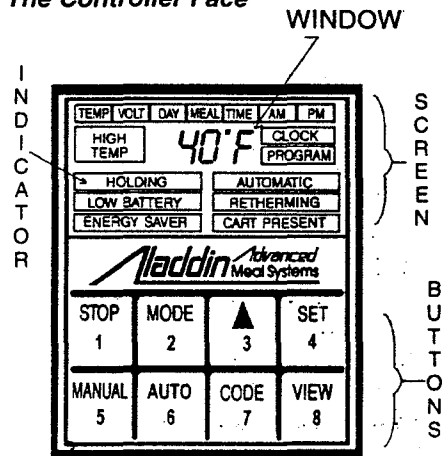

Several locations on the controller will be referred to throughout this manual. It may be helpful to spend a few seconds looking at the figure above. Note that the window and indicators are situated inside the screen. Notice also that there are a total of 16 separate indicators. The buttons will be pressed as directed to perform many controller functions.

III. Programming Controller

NOTE: Controller must not be in "Automatic" mode-See Section VI

A. Security Level 2

To program Magic Touch Controller, Security Level 2 Must be accessed.

- (1) Press **BUTTON 7 (CODE)** -



The **CODE** indicator will appear in the window. A 10 second time limit between button selections is in effect until the completion of Step (3).

- (2) Enter the 4 (four) button security level 2 code in sequence (The default code is shown below).

- BUTTON 1 (STOP)
- BUTTON 4 (SET)
- BUTTON 4 (SET)
- BUTTON 1 (STOP)

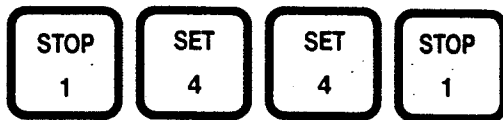

- (3) Press BUTTON 7 (CODE) -

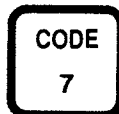

The **SL-2** indicator will appear briefly in the window, and the **PROGRAM** indicator will be highlighted on the screen; proceed to "Section B" after "SL-2" disappears, and the window clears. Repeat Step (1) through Step (3) if "SL-O" or the refrigerator temperature appears in the controller window

B. Programming Meal Times

- (1) Press BUTTON 4 (SET) -



The **DAY** indicator and a number representing the day of week will flash.

- (2) Press BUTTON 3 (▲) to select the day of the week (1 to 7). (Example: 1 = Sunday)



- (3) Press BUTTON 4 (SET) -



The **MEAL** indicator and the meal number will flash.

- (4) Press BUTTON 3 (▲) to select meal (1-6, which indicates the different meals.) (Example: 1 = Breakfast)



- (5) Press BUTTON 4 (SET) -



The **TIME** indicator and the hour will flash.

- (6) Press BUTTON 3 (▲) to select the hour of time the meal is to be completed.

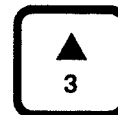

- (7) Press BUTTON 4 (SET) -



The **TIME** indicator and the ten's digit will flash.

- (8) Press BUTTON 3 (▲) to select the minute (ten's digit) the meal is to be completed.



MAGIC TOUCH CONTROLLER -3

- (9) Press **BUTTON 4 (SET)** -



The **TIME** indicator and the one's digit will flash.

- (10) Press **BUTTON 4 (SET)** -



The current **AM** or **PM** setting will flash.

- (11) Press **BUTTON 3 (▲)** to select the **AM** or **PM** indicator.



- (12) Press **BUTTON 4 (SET)** -



The window will clear, setting complete.

- (13) To continue setting meal times proceed with Step 1 through Step 12*.



- (14) **PROCEED TO NEXT SECTION**

*12:00 AM is ignored by the controller. Any meal time set to 12:00 AM will not retherm.

C. Setting the 12 Hour AM/PM Clock

The controller's clock can be set by following the steps below:

- (1) Press **BUTTON 2 (MODE)** until the **CLOCK** indicator is highlighted.



- (2) Press **BUTTON 4 (SET)**



The **DAY** indicator along with "1" will flash.

- (3) Press **BUTTON 3 (▲)** to select the day of the week (1-7). (Example: 1 = Sunday)



- (4) Press **BUTTON 4 (SET)** -



The **TIME** indicator along with the hour will flash.

- (5) Press **BUTTON 3 (▲)** to select the hour of time.



- (6) Press **BUTTON 4 (SET)** -



The **TIME** indicator and the ten's digit will flash.

- (7) Press **BUTTON 3 (▲)** to select the minute (ten's digit).



- (8) Press **BUTTON 4 (SET)**



The **TIME** indicator and the one's digit will flash.

- (9) Press **BUTTON 3 (▲)** to select the minute (one's digit).



- (10) Press **BUTTON 4 (SET)** -



The **AM** or **PM** indicator will flash.

- (11) Press **BUTTON 3 (▲)** to select **AM** or **PM**.



- (12) Press **BUTTON 4 (SET)** - the window will clear, setting complete.

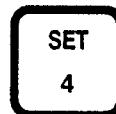

- (13) **PROCEED TO NEXT SECTION**

D. Energy Saver

The **ENERGY SAVER** feature works as follows:

If **ENERGY SAVER** is turned on, 15 minutes after the last programmed meal time of the day, and up until 1 1/2 hours before the first programmed meal time of the day, the refrigeration is "off". If, however, a cart is plugged in during the "off" period, the refrigeration will automatically come back on. At all times other than those mentioned above, the refrigeration is "on".

Follow the Steps below to initiate the **ENERGY SAVER** feature.

- (1) Press **BUTTON 2 (MODE)** until the **ENERGY SAVER** is highlighted.

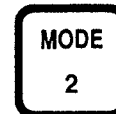

- (2) Press **BUTTON 4 (SET)** -

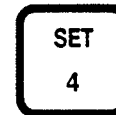

The current **ON** or **OFF** time will appear.

- (3) Press **BUTTON 3 (▲)** to select **ON** or **OFF**.

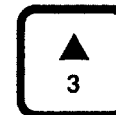

- (4) Press **BUTTON 4 (SET)** -



MAGIC TOUCH CONTROLLER -3

The window will clear, setting complete.

- (5) PROCEED TO NEXT SECTION

E. Retherm Cycle Countdown

The standard 36 minute countdown can be changed from 1 to 99 minutes.

IT IS NOT ADVISABLE TO CHANGE THIS SETTING WITHOUT CONSULTING ALADDIN SYNERGETICS, INC.

- (1) Press **BUTTON 2 (MODE)** until the **REHERMING** and **TIME** indicators are highlighted.

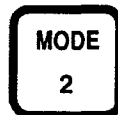

- (2) Press **BUTTON 4 (SET)** -



The current retherm time will appear in window.

- (3) Press **BUTTON 3 (▲)** to select the new retherm time.



- (4) Press **BUTTON 4 (SET)** -



The window will clear, setting complete.

- (5) PROCEED TO NEXT SECTION.

F. High Temp/High Temp Time

The **HIGH TEMP** feature works as follows:

While a cart is present, the controller the amount of time that the refrigerator cabinet has been above a preset temperature. (see below to set the temperature). Should this time add up to more than a preset amount of time, the **HIGH TEMP** indicator will flash, an alarm will sound, and all controller rethermalization functions will lock up. **If this situation occurs, All Food Should Be Discarded.** The system will reset when the cart is unplugged and re-engaged.

The cabinet temperature and the time frame mentioned above are both adjustable. The temperature is adjustable from 32° to 50° F., and the time from 60 to 180 minutes.

- (1) Press **BUTTON 2 (MODE)** until the **HIGH TEMP** indicator is highlighted.

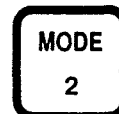

- (2) Press **BUTTON 4 (SET)** -



The current temperature setting will flash.

- (3) Press **BUTTON 3 (▲)** to select temperature limit (32° to 50° F.)



- (4) Press **BUTTON 4 (SET)** - the window will clear.



- (5) Press **BUTTON 2 (MODE)** -



The **HIGH TEMP** and **TIME** indicators will be highlighted.

- (6) Press **BUTTON 4 (SET)** -



- (7) Press **BUTTON 3 (▲)** to select time setting (60 to 180 minutes in 10 minute increments.)



- (8) Press **BUTTON 4 (SET)** -



- (9) PROCEED TO NEXT SECTION

G. Temperature Display (Degrees Fahrenheit or Degrees Celsius)

The temperature readout in the controller window is displayed in degrees Fahrenheit; however, this can be changed to display degrees Celsius. Follow the steps below to set:

- (1) Press **BUTTON 2 (MODE)** until the **C** or **F** indicator is displayed in the window.

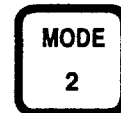

The **C** or **F** will be displayed in the window.

- (2) Press **BUTTON 4 (SET)** -



The current setting will appear in the window.

- (3) Press **BUTTON 3 (▲)** to select Celsius or Fahrenheit.



- (4) Press **BUTTON 4 (SET)**



The **C** or **F** indicator will reappear in the window, setting complete.

- (5) PROCEED TO NEXT SECTION

H. The HOLDING Cycle

At the completion of a **MANUAL** or **AUTOMATIC** retherm cycle, the controller can begin a **HOLDING** cycle, in which it waits 4 minutes and then powers the cart 2 extra minutes. This cycle is repeated twice. During the cycle, the **HOLDING** indicator will flash.

MAGIC TOUCH CONTROLLER -3

Follow the steps below to activate or incorporate the **HOLDING** feature:

- (1) Press **BUTTON 2 (MODE)**



The **HOLDING** indicator is highlighted.

- (2) Press **BUTTON 4 (SET)** -



The current **ON** or **OFF** indicator will appear in the window.

- (3) Press **BUTTON 3 (▲)** to select **ON** or **OFF** indicator.



- (4) Press **BUTTON 4 (SET)** - the window will clear.



- (5) PROCEED TO NEXT SECTION

I. Changing Security Codes

If desired, the two security codes can be changed by the following steps:

Changing Security Level 1:

- (1) Press **BUTTON 2 (MODE)**

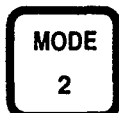

"Cod1" appears in the window.

- (2) Press **BUTTON 4 (SET)** -



- (3) Press and remember any button or sequence of buttons. **Do not use BUTTON 7 (CODE)** -

The **CODE** indicator will appear, setting complete

The security level 1 code is now the sequence of buttons chosen in Step (3)

Changing Security Level 2:

- (1) Press **BUTTON 2 (MODE)** until the description "**Cod2**" appears in the window.

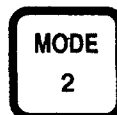

- (2) Press **BUTTON 4 (SET)** -

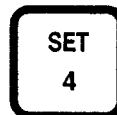

The **CODE** indicator will appear in the window.

- (3) Press and remember any button or sequence of buttons **except BUTTON 7 (CODE)** -

The **CODE** indicator will remain in the window

The security level 2 code is now the sequence of buttons chosen in Step (3).

Contact Aladdin's Service Department (1-800-888-5426) if this coded information is lost.

- (4) PROCEED TO NEXT SECTION

J. Leaving Security Level 2

As mentioned previously, the second security level must be exited at the end of any programming session. This can be accomplished by simply pressing **BUTTON 7 (CODE)** once, and waiting 10 seconds, or just press **BUTTON 7 (CODE)** twice to exit immediately. In either case, "SL-0" will appear briefly and then the refrigerator temperature will display on the screen.

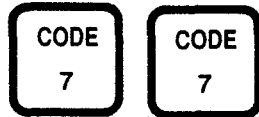

IV. Cart Present Indicator

The **CART PRESENT** indicator is highlighted when a cart is electrically mated inside a refrigerator. Each time a cart is plugged into a refrigerator, glance at the controller screen and make sure **CART PRESENT** is highlighted.



V. Placing Controller in Automatic Mode

The Magic Touch Controller defaults to the **AUTOMATIC** mode after completion of a manual cycle.

In order for the controller to acknowledge and initiate programmed meal times, the controller must be in the **AUTOMATIC** mode.

The desired meal times must be programmed into the controller's memory before running the **AUTOMATIC** mode (See Section III, "Programming Controller" for complete instructions

Follow the steps below to place controller into **AUTOMATIC** mode:

- (1) Press **BUTTON 7 (CODE)** -



The **CODE** indicator will appear in the window, a 10 second time limit between button selections is in effect until the completion of Step (3).

- (2) Enter the two button **SECURITY LEVEL 1** code in sequence (The default code is shown below):

- **BUTTON 1 (STOP)**
- **BUTTON 4 (SET)**



- (3) Press **BUTTON 7 (CODE)** -

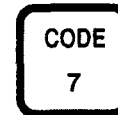

Wait for the **SL-1** indicator to disappear from the controller window and the temperature display to return. Repeat Step (1) through Step (3) should "SL-0" briefly appear in the controller window.

- (4) Press **BUTTON 6 (AUTO)** -

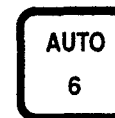

The **AUTOMATIC** indicator will be highlighted on the screen if the previous steps have been correctly implemented.

A cart must be mated inside the refrigerator before the scheduled retherm time.

MAGIC TOUCH CONTROLLER -3

Should the cart be plugged into the refrigerator after the scheduled start time, a solid tone alarm will sound and the **CART PRESENT** indicator will flash. Unplugging the cart will silence the alarm and reset the system. If the cart needs to be immediately rethermed, the cycle *must be started manually* (see Section VII "Starting a Retherm Cycle Manually" for complete instructions). **WARNING:** The controller does not allow a cart to be removed during a retherm cycle. The countdown will be abandoned should this occur.

VI. Getting Out Of Automatic

The controller's **AUTOMATIC** mode must be exited in order to start a manual retherm cycle or to program in the second security level. (If the **AUTOMATIC** indicator is darkened on the controller screen, then this mode has already been exited.)

- (1) Press **BUTTON 1 (STOP)** -



The **CODE** indicator will appear in the window, a 10 second time limit between button selections is in effect until the completion of Step (3).

- (2) Enter the two button **SECURITY LEVEL 1** code in sequence (The default code is shown below).

- **BUTTON 1 (STOP)**
- **BUTTON 4 (SET)**



- (3) Press **BUTTON 7 (CODE)** -

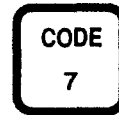

The **AUTOMATIC** indicator will darken. Repeat these steps if "nogo" appears briefly in the window and the **AUTOMATIC** indicator continues to be highlighted.

VII. Starting a Retherm Cycle Manually

You must leave the **AUTOMATIC** mode before proceeding (see section VI, "Getting out of the **AUTOMATIC** mode" for complete instructions). Upon completion of a manual retherm cycle, the controller will default to **AUTOMATIC**.

Follow the steps below to manually start a retherm cycle:

- (1) Place cart inside refrigerator - the **CART PRESENT** indicator will be highlighted.

- (2) Press **BUTTON 7 (CODE)** - the **CODE** indicator will appear, a 10 second time limit between button selections is in effect until the completion of Step (4).

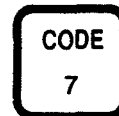

- (3) Enter the two button **SECURITY LEVEL 1** code in sequence (The default code is shown below):

- **BUTTON 1 (STOP)**
- **BUTTON 4 (SET)**





- (4) Press **BUTTON 7 (CODE)** - the **SL-1** indicator will briefly appear in the window, proceed to Step (5) after "SL-1" disappears and the temperature display returns.

Repeat Steps (2) through (4) should "**SL-0**" briefly appear in the window, this means that the code sequence was entered incorrectly or too much time was taken between button selections.



- (5) Press **BUTTON 5 (MANUAL)** - the **REHERMING** indicator will be highlighted and the countdown display will appear.*

*Attempting to start a manual retherm cycle without a cart being present will result in a 3 second alarm, and the **SECURITY LEVEL 1** code will have to be reentered. Should a cart be removed during a retherm cycle, the rethermalization power will be switched off, and the countdown abandoned.

VIII. Stopping a Retherm Cycle

There are two ways to stop a retherm cycle in progress. The first is to simply unplug the cart. The second is by following the steps below:

- (1) Press **BUTTON 1 (STOP)** -



The **CODE** indicator will appear

in the window, a 10 second time limit between button selections is in effect until the completion of Step (3).

- (2) Enter the two button **SECURITY LEVEL 1** code in sequence (The following is the default code.)

- **BUTTON 1 (STOP)**
- **BUTTON 4 (SET)**

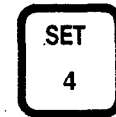

- (3) Press **BUTTON 7 (CODE)** -

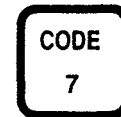

The countdown display will disappear and the **REHERMING** indicator will darken.

Repeat Steps (1) through Step (3) if "**nogo**" appears briefly in the window and the controller continues to count down.

The cart must be removed before initiating another retherm cycle.

IX. Low Battery Indicator

The controller's clock is protected from power outages by a standard 9v battery. When this battery needs replacing, the **LOW BATTERY** indicator will flash.

See section VI. B. in Retherm Refrigerator Manual (BATTERY REPLACEMENT)

MAGIC TOUCH CONTROLLER -3

X. Set Clock Indicator

The Set Clock Indicator will flash "Set Clock" if power to the Magic Touch Controller has been discontinued. If this indicator is flashing, the 12 hour clock must be set before Magic Touch Controller can be put into an automatic cycle. The Controller can be run in manual mode, if required, before resetting the 12 hour clock. Refer to Section III. C. "Setting the 12 Hour AM/PM Clock" and Section V. A. in Retherm Refrigerator Manual "Defrost Cycle".

XI. Compensation of Low Voltage and Voltage Display

Voltage available to the system can be displayed on the controller screen by pressing the **BUTTON 8 (VIEW)** button.



Should this voltage drop to inadequate levels, the controller will automatically compensate in the manner described below.

During any retherm cycle, should the cart voltage drop below 117 volts AC, the controller switches in a boost transformer. The controller updates its decision to boost every minute; therefore, food will not be scorched should the voltage drop for a few minutes and then return to normal.

Voltage displayed is input voltage. Should voltage be boosted, only input voltage will be displayed, not boosted voltage.

XII. Other Controller Features

- A. The controller allows for up to three minute power outages during a retherm cycle without abandoning the countdown. Should power return after 3 minutes, a solid alarm sounds and **CART PRESENT** flashes. The system can be reset by unplugging the cart and re-engaging it.
- B. At the end of a retherm cycle, **MEALTIME** flashes, **HOLDING** flashes (if this feature has been enabled), an alarm sounds. After the **HOLDING** cycle has been completed, the refrigerator cabinet temperature display returns.
- C. During a power outage and with a properly charged battery, the **CART PRESENT** indicator will appear even if no cart is plugged in.

Troubleshooting Tips and Service

<i>Problem/Concern</i>	<i>Possible Causes and Solutions</i>
1. A programmed meal time was skipped.	<ol style="list-style-type: none"> 1. Verify the controller is in the AUTOMATIC mode. 2. Verify the controller's clock is set correctly. 3. Verify the program setting is correct. 4. Cart engaged after programmed start of mealtime. 5. The refrigerator door was open. 6. Check controller's complete wiring harness for loose connections (electrician).
2. The CART PRESENT indicator does not come on when a cart is present.	<ol style="list-style-type: none"> 1. Verify the cart is fully engaged. 2. Verify cart sensing switch, (underneath receptacle in refrigerator) is operating properly (place metal object over switch and observe CART PRESENT indicator). 3. Verify metal bar is on cart directly below plug.
3. The CART PRESENT indicator remains on screen, even if no cart is present.	<ol style="list-style-type: none"> 1. Check if cart sensing switch, underneath cart male receptacle in refrigerator is operating properly (place metal object over switch and observe CART PRESENT indicator). 2. Check if controller's wiring harness is loose (electrician). 3. Check resistor connection in controller wiring harness (electrician). 4. Check to see if controller is running on DC power only.
4. The controller counts down, but the cart does not heat.	<ol style="list-style-type: none"> 1. The refrigerator door was open. 2. Check all refrigerator breakers (electrician). 3. Check for power to refrigerator (electrician). 4. Check controller's complete wiring harness for loose connections. (electrician). 5. Check refrigerator contactors for proper switching operation (electrician).
5. The controller is displaying excessively high temperatures.	<ol style="list-style-type: none"> 1. A warm cart may have been placed inside refrigerator recently. 2. The refrigerator door may have been open. 3. Check if the energy saver feature is active. 4. Check refrigerator breakers and voltage (electrician). 5. See if refrigerator is in a defrost cycle. 6. Contact Aladdin's Service Department.
6. The temperature reading drops when a cart is plugged into the refrigerator.	<ol style="list-style-type: none"> 1. Check the proximity switch resistor - should be 4.7 Kohms (electrician). 2. Check if temperature sensors metal case is shorting to ground (electrician). 3. Check temperature probes wiring for any shorts (electrician).
7. A continuous alarm is sounding and the HIGH TEMP indicator is flashing.	<ol style="list-style-type: none"> 1. The cart inside the refrigerator has been exposed to excessively high temperature for a specified period of time (see Section III F of this manual) Unplug cart to reset.

MAGIC TOUCH CONTROLLER -3

Troubleshooting Tips and Service (Continued)

<i>Problem/Concern</i>	<i>Possible Cause and Solutions</i>
8. A continuous alarm is sounding and the CART PRESENT indicator is flashing.	<ol style="list-style-type: none"> 1. The cart inside the refrigerator was plugged in after an AUTOMATIC cycle was set to begin (see Section 5 of this manual). Unplug and reset. 2. Power went out to the refrigerator for over 3 minutes during a retherm cycle (see Section XII of this manual). Unplug cart to reset. 3. Check controller voltage display. If reading is less than 100 volts, check voltage at refrigerator load center (electrician). If readings do not agree, within a few volts, contact Aladdin Service Department.
9. A continuous alarm sounded for only a few seconds.	<ol style="list-style-type: none"> 1. A manual retherm cycle was attempted with no cart plugged in (see Section of this manual).
10. A pulsing alarm is sounding and the MEAL TIME indicator is flashing.	<ol style="list-style-type: none"> 1. The cart inside the refrigerator has been rethermed. remove. Indicator is flashing the cart to reset.
11. The LOW BATTERY indicator is flashing.	<ol style="list-style-type: none"> 1. Replace controller's 9v battery (see Section IX of this manual).
12. Only every other shelf in a cart heated.	<ol style="list-style-type: none"> 1. Not associated with the controller, check cart mating. 2. Check all contactors (electrician). 3. Check power to refrigerator (electrician). 4. Check cart.
13. Individual shelves (or pods) in cart not heating.	<ol style="list-style-type: none"> 1. Not associated with the controller, check retherm cart.
14. Controller indicators (excluding LOW BATTERY and HOLDING) are flashing without an alarm.	<ol style="list-style-type: none"> 1. Unplug all controller connectors and then re-plug. If flashing still occurs, replace controller (electrician).
15. A retherm cycle was completed but no alarm sounded.	<ol style="list-style-type: none"> 1. Check alarm by attempting to start a manual retherm cycle with <u>no</u> cart present. 2. Check alarm wirings for loose connections (electrician).
16. "SL-0" briefly appeared while entering a security code.	<ol style="list-style-type: none"> 1. The code was incorrectly entered or too much time elapsed between button selections.
17. I thought I was in security level 1 but pressed START MANUAL and the controller did not begin retherm.	<ol style="list-style-type: none"> 1. Re-enter the security level 1 code and watch for "SL-1" to briefly appear in the window before pressing START MANUAL. See number 17 if "SL-0" appears.
18. I thought I was in security level 1, but pressed START AUTO and the AUTOMATIC indicator did not appear.	<ol style="list-style-type: none"> 1. Re-enter the security level 1 code and watch for "SL-1" to briefly appear in the window, before pressing START AUTO. See number 15 if "SL-0" appears.
19. I thought I exited the AUTOMATIC mode, but the automatic indicator is still displayed.	<ol style="list-style-type: none"> 1. You may have forgotten to press STOP first before entering your security code. See Section 6 of this manual.
20. I thought I properly stopped the retherm cycle, but the controller is still counting down and displaying the REHERMING indicator.	<ol style="list-style-type: none"> 1. You may have forgotten to press STOP first before entering your security code. See Section 4 of this manual.

**R61THKD
R62THKD
REETHERMALIZATION
REFRIGERATORS**

Part 3

**DRAWINGS, PARTS LIST
& WIRING DIAGRAMS**

INSTALLATION, OPERATION & MAINTENANCE MANUAL

RE THERMALIZATION REFRIGERATORS

DRAWINGS / R61THKD

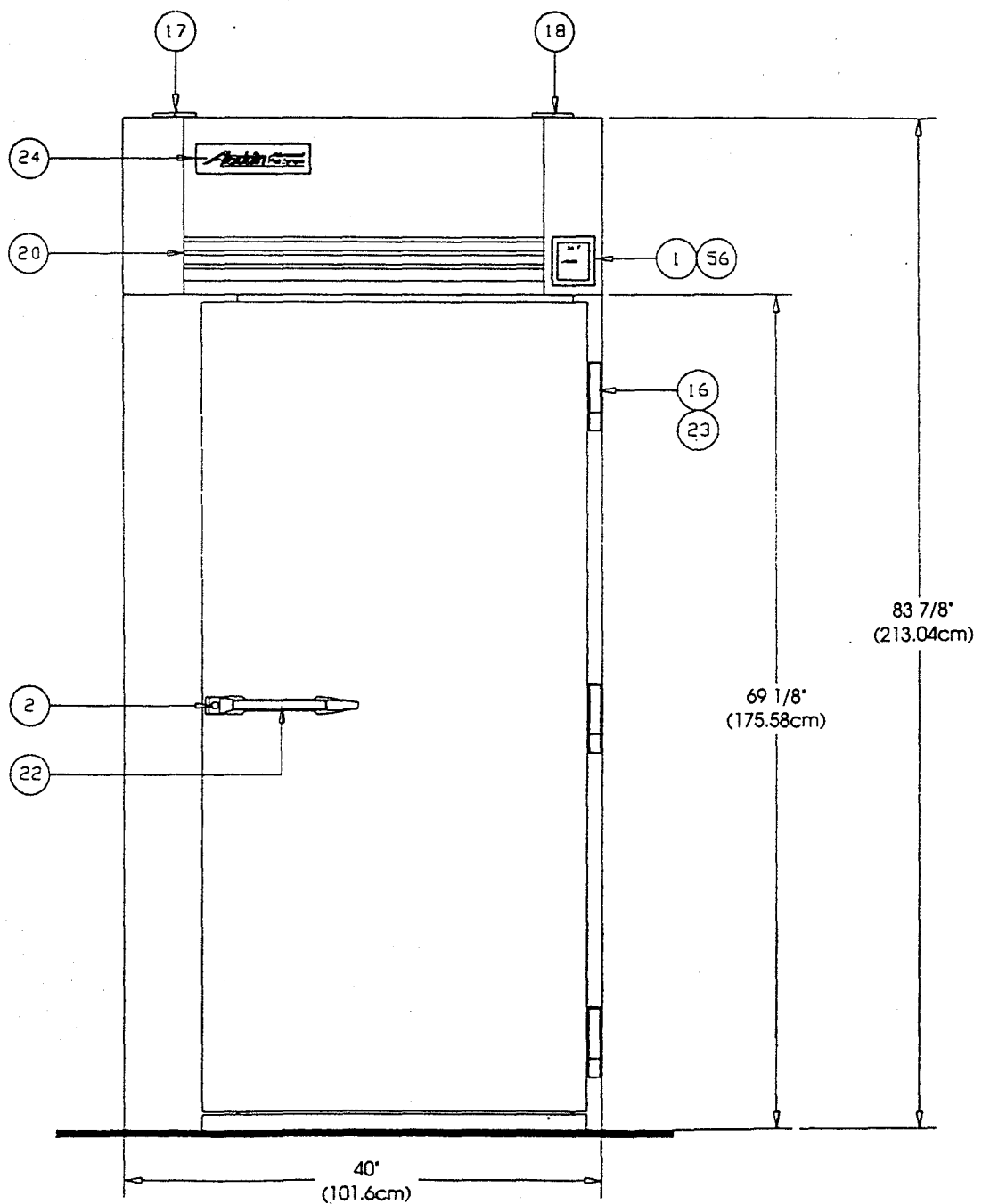

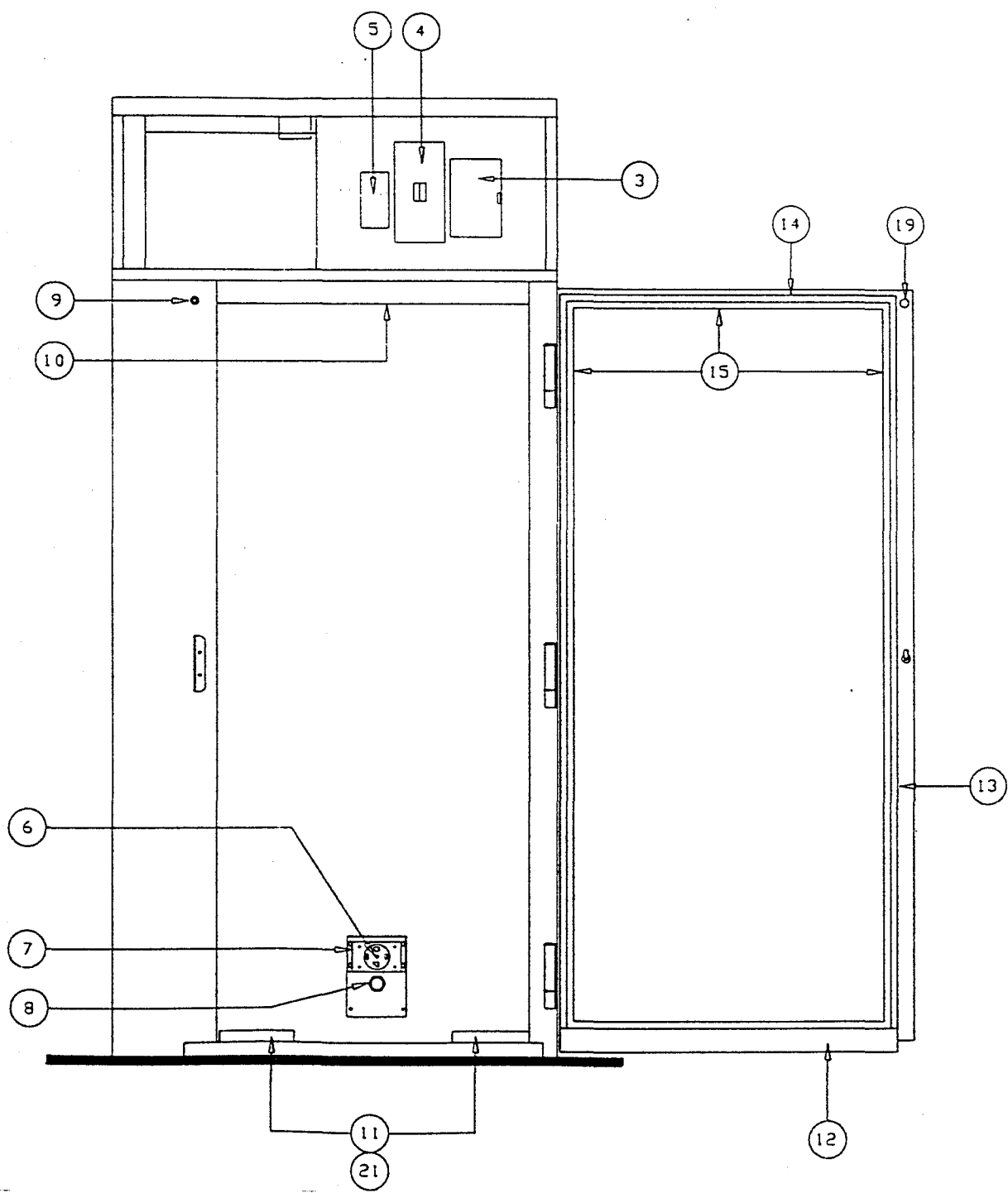

RE THERMALIZATION REFRIGERATORS

PARTS LIST

R61THKD Single Bay

Refer to Drawing R61THKD on pages 30 & 31 for item # Correlation

No.	Part No.	Qty.	Description	No.	Part No.	Qty.	Description
1	39855	1	Magic Touch Timer 3	29	28803	1	Piezo Alarm Buzzer
2	39656	1	Handle Lock Assembly #1315	30	E-14-29	1	Bridge Rectifier
	39396	2	Door Key #1315	31	E-3-2-1	1	3 Wire 70A Load Center w/Cover
	39393	1	Door Lock Cylinder #1315	32	E-3-8-1	1	Square "D" Ground Bar
3	39468	1	Defrost Timer (120v, 60hz)	33	24677	1	9v Alkaline Battery
4	E-3-2-1	1	Breaker Enclosure	34	E-14-22	1	9v Battery Holder
5	39660	1	Thermostat Control	35	E-3-18-2	1	Square "D" Handle Tie
6	39182	1	Cart Receptacle 4-Prong	36	39524	2	20A, 2Pole Circuit Breaker
7	29313	1	Valox Spacer	37	29918	1	15-Pin Amp Terminal Housing
8	39058	1	Proximity Sensor	38	29917	1	14-Pin Amp Terminal Housing
9	21043	1	Door Switch	39	29919	1	6-Pin Amp Terminal Housing
10	39053	1	Temperature Sensor	40	29916	1	11-Pin Amp Terminal Housing
11	28511	2	Cart Caster Guide	41	39185	1	P&B Relay
12	39655	2.4	Door Sweep Gasket	42	28407	1	Boost Transformer
13	39654	2	Gasket Retainer 65-9/16	43	29528	1	Voltage Sensor, ACMU
14	39653	2	Gasket Retainer 30-1/4	44	39183	1	Contactora
15	39652	1	3-Sided Magnetic Gasket	45	39579	1	2Amp Circuit Breaker
16	39225	3	Door Hinges	46	28849	1	Resister, 4.7K
17	39650	1	LH Access Panel Hinge	47	E-5-210	1	Heater Tape, 210" (double) 155V/3W
18	39651	1	RH Access Panel Hinge	48	24726	2	C-Frame motor,#4M073, 300RPM
19	ALD006.005	1	Door Switch Bumper	49	P-1-209	1	FJAF-A050-IAA, Condensing unit
20	39218	3'	Refrigerator Trim Tape	50	39660	1	Control Thermostat
21	29654	8	Cart Guide Plug	51	24725	1	Condensate Pan 160Watt
22	39410	1	Black Plastic Strip for door Handle	52	E-14-41	1	Harness Main Control, #257-1119
23	39226	3	Plastic Hinge Insert	53	E-14-42	1	Harness, Main Power, #257-1118
24	28273	1	AMS Plain Name Plate	54	39763	1	Capacitor 470 UF
25	E-14-15	1	Dayton 30a DPDT 24V AC Coil Contactor	55	39788	1	Potentiometer
26	39184	3	20a 2 Pole 24V AC Coil Contactor	56	39609	1	Mallory Glare Shield
27	39657	1	Control Transformer				
28	39659	1	AC Line Filter				



OPEN FOR R61THKD WIRING DIAGRAM

RE THERMALIZATION REFRIGERATORS

DRAWINGS / R62THKD

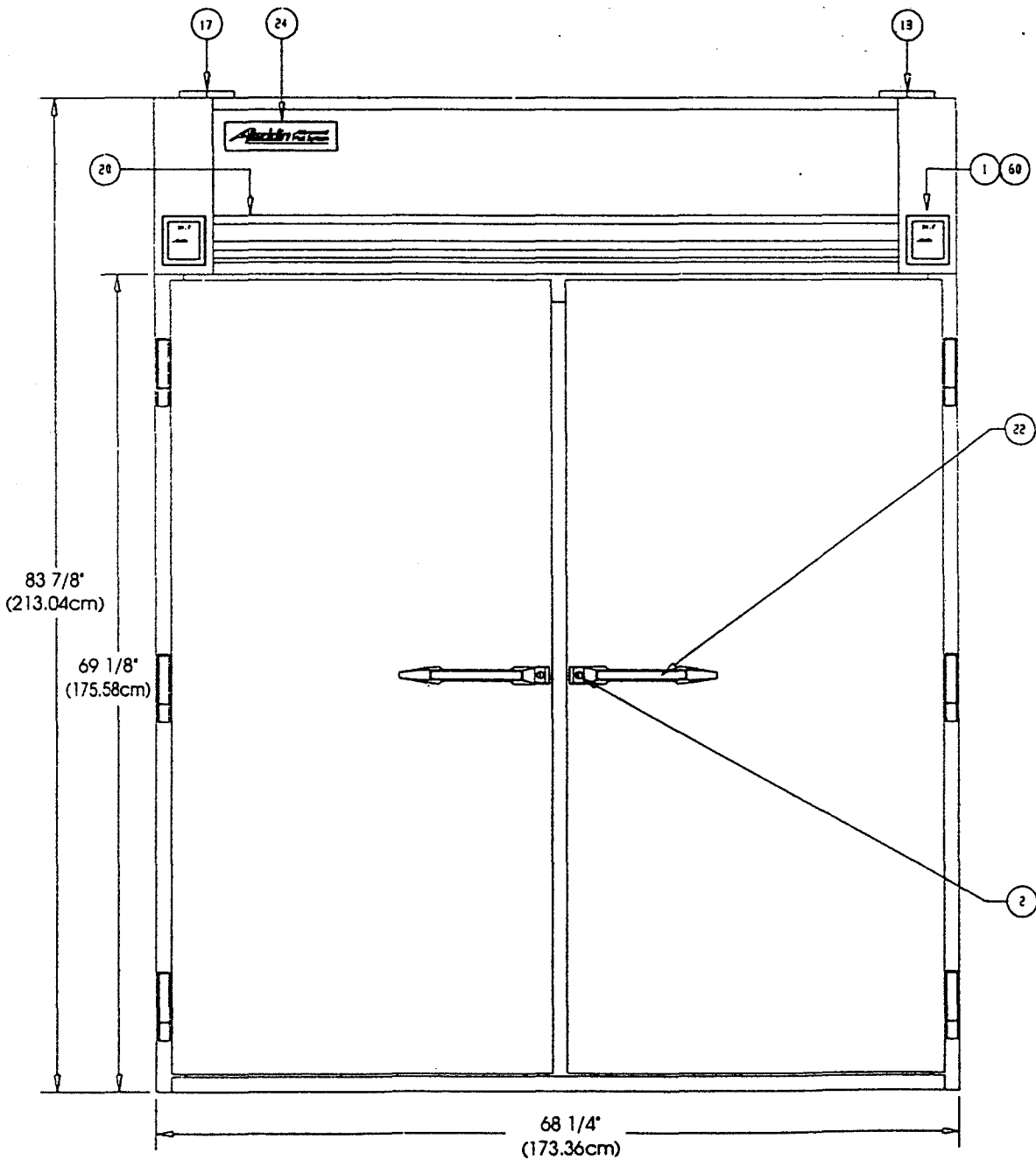

RE THERMALIZATION REFRIGERATORS

WIRING DIAGRAMS R61THKD

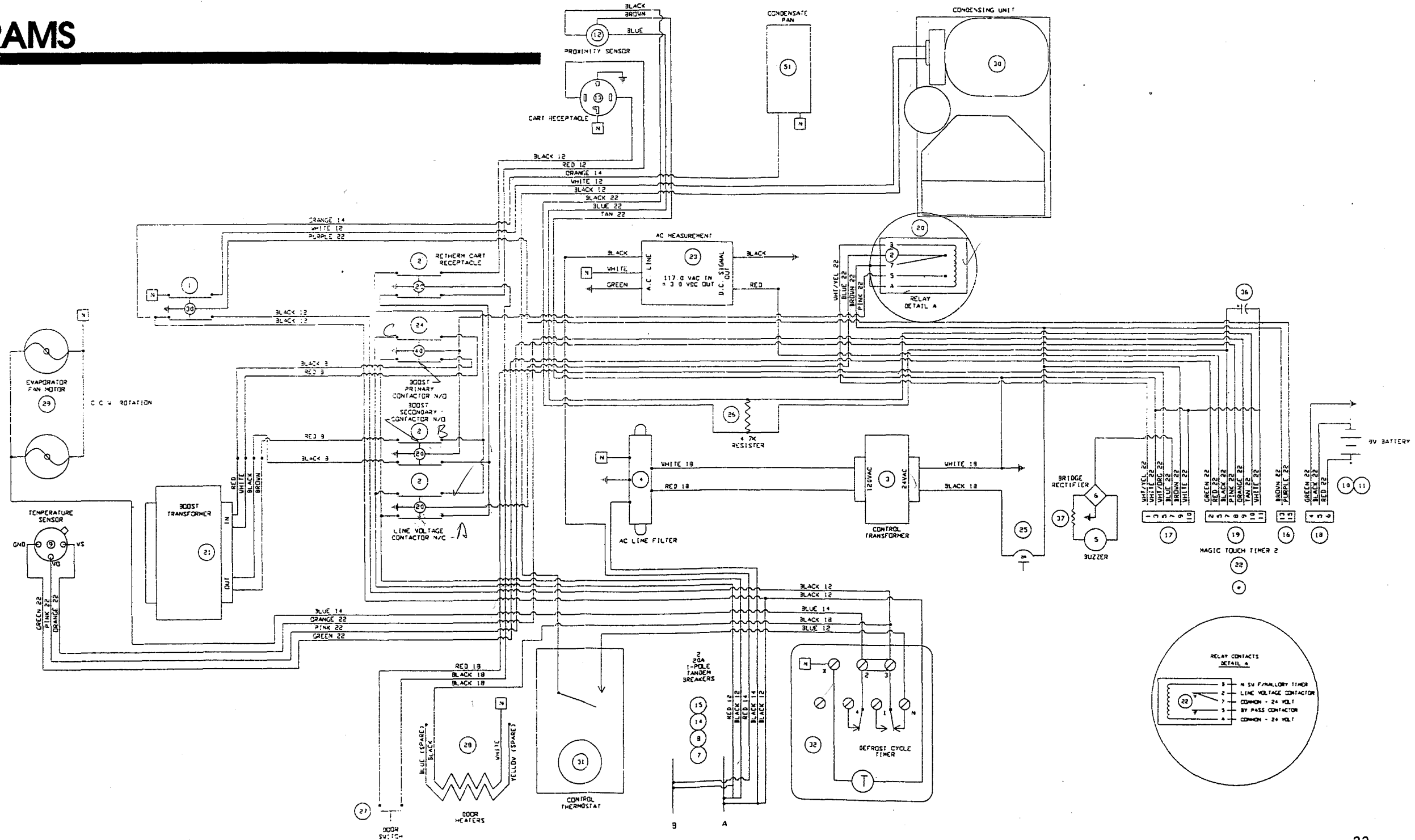

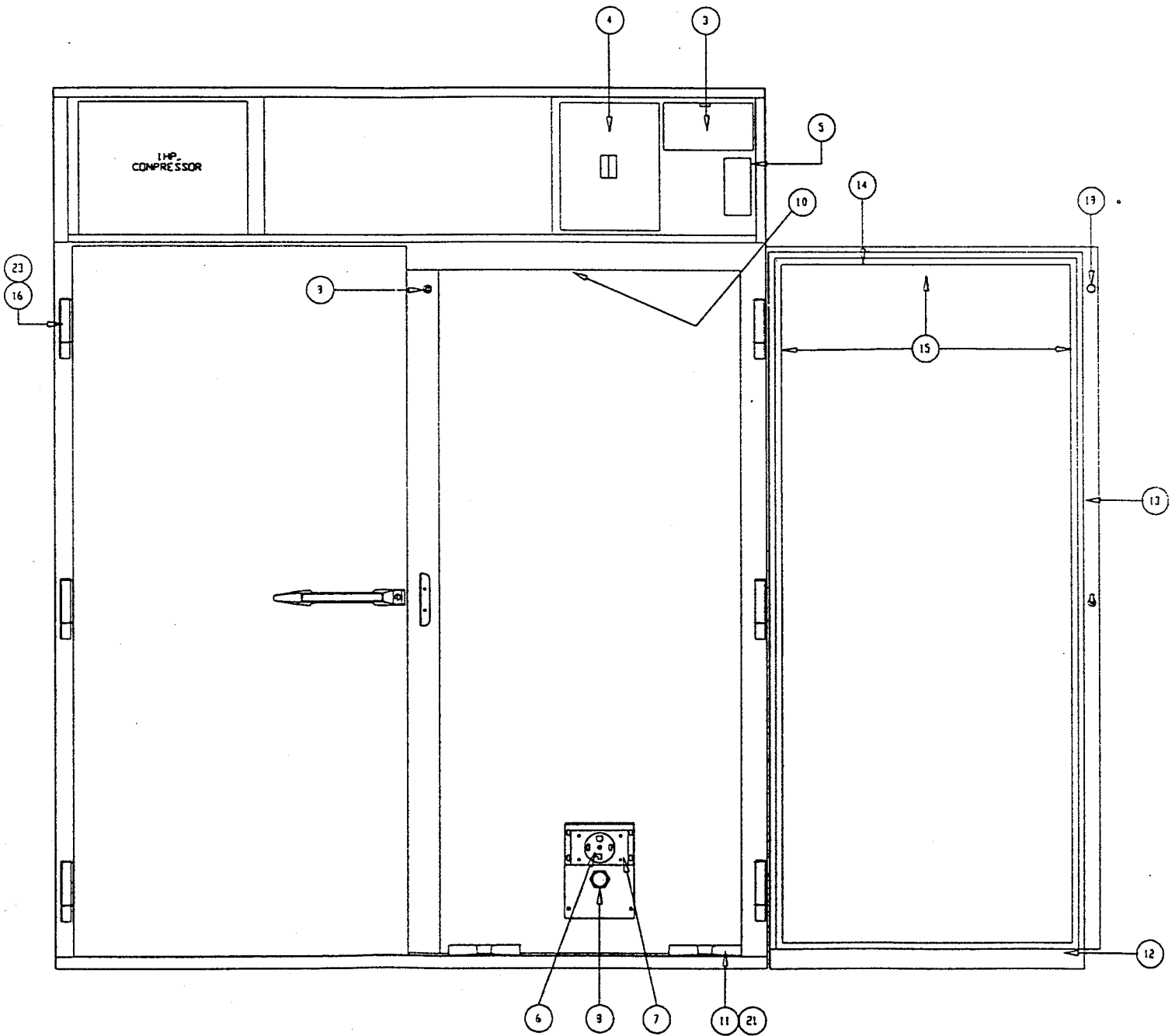

PARTS LIST

R62THKD Double Bay

Refer to Drawing R62THKD on page 35 & 36 for item# Correlation

No.	Part No.	Qty.	Description	No.	Part No.	Qty.	Description
1	39855	2	Magic Touch Controller 3	31	E-3-30-4	1	20A, 2 Pole Circuit Breaker
2	39656	2	Handle Lock Assembly #1315	32	24677	2	9v Alkaline Battery
	39396	4	Door Key #1315	33	E-14-22	2	9v Battery Holder
	39393	2	Lock Cylinder #1315	34	E-3-13	1	SQD 40a 2Pole Breaker Q0220
3	39668	1	Defrost Timer (120v, 60hz)	35	E-3-15	1	SQD 20a 2Pole Breaker Q0240
4	E-3-2	1	Breaker Enclosure	36	29918	2	15-Pin Amp Terminal Housing
5	39660	1	Thermostat Control	37	29917	2	14-Pin Amp Terminal Housing
6	39182	2	Receptacle	38	29919	2	6-Pin Amp Terminal Housing
7	29313	2	Valox Spacer	39	29916	2	11- Pin Amp Terminal Housing
8	39058	2	Proximity Sensor	40	E-3-18-1	1	SQD Ground Bar #PK7GTA
9	21043	2	Door Switch	41	39185	1	P&B Relay
10	39053	1	Temp. Controller Thermister	42	39183	2	40A 2Pole Contactor
11	28511	2	Cart Caster Guide	43	28407	1	Boost Transformer
12	39655	4.8	Door Sweep Gasket	44	29526	2	Magic Touch Timer
13	39654	4	Gasket Retainer 65-9/16	45	29528	1	Voltage Sensor, ACMU
14	39653	4	Gasket Retainer 30-1/4	46	39579	1	2Amp Circuit Breaker
15	39652	2	3-Sided Magnetic Gasket	47	28849	2	Resister. 4.7K
16	39225	6	Door Hinge	48	E-3-30-5	2	Bracket. ITE #Smp-6
17	39650	1	LH Access Panel Hinge	49	E-5-256	1	Heater Tape.256' (Double) 120v/3w
18	39651	1	RH Access Panel Hinge	50	24726	2	C-Frame Motor,#4M073, 300RPM
19	ALD006.005	2	Door Switch Bumper	51	P-1-211	1	FJAF-A100-CAV, Condensing Unit
20	39218	5.5'	Refrigerator Trim Tape	52	39660	1	Control Thermostat
21	29654	8	Cart Stall Plug	53	39468	1	Defrost Timer, 120v/60hz
22	39410	2	Black Plastic Strip for Handle	54	24725	1	Condensate Pan 160 Watt
23	39226	6	Plastic Hinge Insert	55	E-5-25	1	S/S Tublar Heater-LH
24	28273	1	AMS Plain Name Plate	56	E-5-26	1	S/S Tublar Heater-RH
25	E-14-15	1	Dayton 30a DPDT 24v AC Coil Contactor	57	E-3-412	1	SQD 75a 24v Coil Contactor DPA-72V14
26	39184	2	20a 2Pole 24v AC Coil Contactor	58	39763	2	Capacitor-470 UF
27	39658	1	Control Transformer	59	39788	2	Potentiometer
28	39659	1	AC Line Filter	60	39609	2	Mallory Glare Shield
29	28803	2	Piezo Alarm Buzzer				
30	E-14-29	2	Bridge Rectifier				



OPEN FOR R62THKD WIRING DIAGRAM

RE THERMALIZATION REFRIGERATORS

WIRING DIAGRAMS

R62THKD

