

ALTO-SHAAM®

**Convection Oven
Gas**

PLATINUM SERIES



Model:

ASC-4G

**Electronic
Control**

- **INSTALLATION**
- **OPERATION**
- **MAINTENANCE**

W164 N9221 Water Street • P.O. Box 450
Menomonee Falls, Wisconsin 53052-0450 U.S.A.

PHONE: 262.251.3800 • 800.558.8744 U.S.A. / CANADA
FAX: 262.251.7067 • 800.329.8744 U.S.A. ONLY
www.alto-shaam.com



Consult instructions
for operation and use.





Delivery. 1
Unpacking 1
Safety Procedures and Precautions. 2

Installation

Site Installation 4
Clearance Requirements 4
Installation Requirements 5
Leveling 5
Dimension Drawings 5
Capacity. 5
Gas Specifications. 6-8
Electrical Connection 9
Ventilation 10
Stacking Instructions. 11-12
Oven Stand Assembly Option 13

Operating Instructions

User Safety Information. 14
Options & Accessories 14
Start-Up Operation 15
Electronic Control Operation and Features 16-19
Chef Operating Tips 20

Care and Cleaning

Cleaning and Preventive Maintenance 21
Protecting Stainless Steel Surfaces 21
Cleaning Agents 21
Cleaning Materials. 21
Clean Daily. 22
Exterior 22
Motor Care. 22

Service

Troubleshooting Guide 23
Full Assembly View 24
Electrical Chassis 25
Interior Oven Compartment View 26
Motor 27
Door Package 28
Door Mechanism 29
Door Hardware 30
Leg Assembly 31

Wire Diagrams

Always refer to the wire diagram(s) included with the unit for most current version.

Warranty

Transportation Damage and Claims . Back Cover
Limited Warranty Back Cover

Delivery

This Alto-Shaam appliance has been thoroughly tested and inspected to ensure only the highest quality unit is provided. Upon receipt, check for any possible shipping damage and report it at once to the delivering carrier. *See Transportation Damage and Claims section located in this manual.*

This appliance, complete with unattached items and accessories, may be delivered in one or more packages. Ensure all standard items and options have been received with each model as ordered.

Save all the information packed with the appliance. Register online at www.alto-shaam.com to ensure prompt service in the event of a warranty parts and labor claim.

This manual must be read and understood by all people using or installing the equipment model. Contact the Alto-Shaam Tech Team Service Department if you have any questions concerning installation, operation, or maintenance.

1-800-558-8744; servicedept@alto-shaam.com

The serial number is required for all inquiries.

Always include both model and serial number(s) in any correspondence regarding the appliance.

Model: _____

Serial number: _____

Purchased from: _____

Date installed: _____ **Voltage:** _____

Unpacking

- Carefully remove the appliance from the carton or crate.

NOTICE: Do not discard the carton and other packaging material until you have inspected the unit for hidden damage and tested it for proper operation.

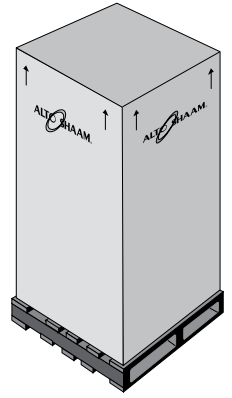

- Read all instructions in this manual carefully before installing this appliance, using the appliance or performing routine maintenance. Following procedures other than those indicated in this guide to use and clean the appliance is considered inappropriate and may cause damage, injury or fatal accidents, in addition to invalidating the guarantee and relieving Alto-Shaam of all liability.
- DO NOT DISCARD THIS MANUAL.** This manual is considered part of the appliance and is provided for the owner or manager of the business and for training personnel. *Additional manuals are available from the Alto-Shaam Tech Team Service Department.*
- Remove all protective plastic film, packaging materials, and accessories from the appliance before connecting electrical power. Store any accessories in a convenient place for future use.



CAUTION



Appliance and accessories may be heavy. To prevent serious injury, **always** use a sufficient number of trained and experienced workers when moving or leveling appliance and handling accessories.

ENVIRONMENTAL CONDITIONS

- Operational Environmental Conditions
- Unit must acclimate to room temperature in the environment it is placed. 24 hours is recommended.
- Ambient temperature range of 60°F to 110°F (16°C to 43°C).
- Relative humidity of less than 95% non-condensation.
- Atmospheric pressure range of 50KPa to 106KPa.

Safety Procedures and Precautions

- This appliance is intended to cook, hold or process foods for the purpose of human consumption. No other use for this appliance is authorized and is therefore considered dangerous. The appliance must not be used to cook food containing flammable materials (such as food with alcohol). Substances with a low flash point can ignite spontaneously and cause a fire.
- This appliance is intended for use in commercial establishments where all operators are familiar with the purpose, limitations, and associated hazards of this appliance. Operating instructions and warnings must be read and understood by all operators and users. We recommend regular training of your staff to avoid the risk of accident or damage to the unit. Operators must also receive regular safety instructions.
- Any trouble shooting guides, component views, and parts lists included in this manual are for general reference only and are intended for use by qualified and trained technicians.
- This manual should be considered a permanent part of this appliance. This manual and all supplied instructions, diagrams, schematics, parts lists, notices, and labels must remain with the appliance if the item is sold or moved to another location.

Knowledge of proper procedures is essential to the safe operation of electrically and/or gas energized equipment. The following hazard signal words and symbols may be used throughout this manual.

DANGER



Used to indicate the presence of a hazard that **WILL** cause severe personal injury, death, or substantial property damage if the warning included with this symbol is ignored.

WARNING



Used to indicate the presence of a hazard that **CAN** cause personal injury, possible death, or major property damage if the warning included with this symbol is ignored.

CAUTION



Used to indicate the presence of a hazard that can or will cause minor or moderate personal injury or property damage if the warning included with this symbol is ignored.

CAUTION

Used to indicate the presence of a hazard that can or will cause minor personal injury, property damage, or a potential unsafe practice if the warning included with this symbol is ignored.

NOTICE: Used to notify personnel of installation, operation, or maintenance information that is important but not hazard related.



Used to indicate that referral to operating instructions is a mandatory action. If not followed the operator could suffer personal injury.



Used to indicate that referral to operating instructions is recommended to understand operation of equipment.

NOTICE: For equipment delivered for use in any location regulated by the following directive: 2012/95/EC WEEE



DO NOT dispose of electrical or electronic equipment with other municipal waste.

Additional Safety Procedures and Precautions

- To prevent serious injury, death or property damage, your appliance should be inspected and serviced at least every twelve (12) months by an authorized service partner or trained technician.
- ONLY allow an authorized service partner or trained technician to service or to repair your appliance. Installation or repairs that are not performed by an authorized service partner or trained technician, or the use of non-factory authorized parts will void the warranty and relieve Alto-Shaam of all liability.
- When working on this appliance, observe precautions in the literature, on tags, on labels attached to or shipped with the appliance and other safety precautions that may apply.
- If the appliance is installed on casters freedom of movement of the appliance must be restricted so that utility connections (including gas, water, and electricity) cannot be damaged when the unit is moved. If the appliance is moved, make sure that all utility connections are properly disconnected. If the unit is returned to its original position, make sure that any retention devices and utility connections are properly connected.
- ONLY use the appliance when it is stationary. Mobile oven racks, mobile plate racks, transport trolleys, and appliances on casters can tip over when being moved over an uneven floor or threshold and cause serious injury.
- ALWAYS apply caster brakes on mobile appliances or accessories when these are not being moved. These items could move or roll on uneven floors and cause property damage or serious injury.
- Be extremely careful when moving appliances because the food trays may contain hot fluids that may spill, causing serious injury.
- ALWAYS open the appliance door very slowly. Escaping hot vapors or steam can cause serious injury or death.

INSTALLATION

⚠ WARNING

Improper installation, alteration, adjustment, service, cleaning, or maintenance could result in property damage, severe injury, or death.

Read and understand the installation, operating and maintenance instructions thoroughly before installing, servicing, or operating this equipment.

⚠ CAUTION



To prevent **personal injury** or **property damage**:

Always use hand protection when operating this appliance to avoid burns. Metal parts of this equipment become extremely hot when in operation.

CAUTION



Do not lift or move the oven by using the doors or the door handles.

⚠ WARNING



To prevent personal injury, death or property damage:

Do not store or use gasoline or other flammable vapors or liquids in the vicinity of this or any other appliance.

SITE INSTALLATION

The Alto-Shaam convection oven must be installed in a location that will permit the oven to function for its intended purpose and to allow adequate clearance for ventilation, proper cleaning, and maintenance.

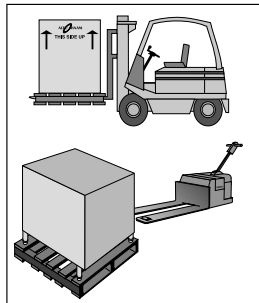

1. Hood installation is required.
(CHECK LOCAL CODES.)
2. The oven must be installed on a stable and level surface. A non-combustible, heat resistant, and fireproof surface is highly recommended. If the oven is to be installed on a combustible surface, factory supplied legs or oven stand **MUST** be used.
3. **DO NOT** install this oven in any area where it may be affected by any adverse conditions such as steam, grease, dripping water, high temperatures, etc.
4. This appliance must be kept free and clear of any combustible materials.
5. This appliance must be kept free and clear of any obstructions blocking access for maintenance or service.

WEIGHT

NET	420 lb	(191 kg)
SHIPPING	465 lb	(211 kg)
CRATE DIMENSIONS:	45" L x 53" W x 49" H (1143mm x 1346mm x 1245mm)	
MINIMUM ENTRY CLEARANCE	31-1/2" (800mm) UNCRATED	

DIMENSIONS H x W x D:

EXTERIOR:	58-1/2" x 38" x 44-1/2" (1486mm x 964mm x 1130mm)	
INTERIOR:	24" x 29-1/8" x 25" (610mm x 740mm x 635mm)	

MINIMUM CLEARANCE REQUIREMENTS

	COMBUSTIBLE SURFACES	NON-COMBUSTIBLE SURFACES
BACK	0" (0mm)	0" (0mm)
LEFT SIDE	2" (51mm)	0" (0mm)
RIGHT SIDE	2" (51mm)	2" (51mm)
FROM GREASE PRODUCING EQUIPMENT	6" (152mm)	6" (152mm)
ENTRY CLEARANCE:	31-1/2" (800mm) UNCRATED	
RECOMMENDED SERVICE ACCESS:	20" (508mm) RIGHT CONTROL SIDE	

GAS SUPPLY & INSTALLATION

GAS SPECIFICATIONS

DANGER



Connecting to the wrong gas supply could result in fire or an explosion causing severe injury and property damage.

GAS PRESSURE CHART

The gas valve and burner have been fitted according to the gas type specified on the identification name plate.

TECHNICAL SPECIFICATIONS

Natural Gas

Min. connected pressure	7.0" W.C.	1.74 kPa
Max. connected pressure	14.0" W.C.	3.48 kPa
Orifice Size	#31	
Manifold pressure	5.0" W.C.	1.25 kPa
Gross thermal output	50,000 Btu/hr	

Propane Gas

Min. connected pressure	11.0" W.C.	2.74 kPa
Max. connected pressure	14.0" W.C.	3.48 kPa
Orifice Size	2.15mm	
Manifold pressure	10.0" W.C.	2.49 kPa
Gross thermal output	50,000 Btu/hr	

INSTALLATION REQUIREMENTS

GAS CONNECTION: 1/2" NPT

CHECK PLUMBING CODES FOR PROPER SUPPLY LINE SIZING TO ATTAIN BURNER MANIFOLD

NOTICE: If a flexible gas line is used, it must be AGA approved, commercial type, and at least 1" I.D.

WARNING



To prevent **SERIOUS PERSONAL INJURY**, installation of this appliance must conform to local, state, and national codes; the current edition of the American National Standard Z223.1, National Fuel Gas Code, and all local municipal building codes. In Canada, installation must be in accordance with Standard CAN/CSA B 149.1 and Installation Codes - Gas Burning Appliances, and local codes.

GAS SUPPLY & INSTALLATION

WARNING



To prevent SERIOUS INJURY, DEATH, or PROPERTY DAMAGE:

Installation, air adjustment and/or service work must be in accordance with all local codes and must be performed by a trained service technician qualified to work on gas appliances.

Gas Requirements

The gas inlet is located at the back of the oven. Code requires the installation of a manual gas shutoff valve to be installed in the gas line ahead of the oven. This oven is also equipped with fixed burner orifices determined by the elevation specified as the initial installation location.

The oven is furnished with a regulator integral to the operation of the gas solenoid valve and may not require an additional external regulator. To ensure safe and proper operation, the gas pressure regulator installed in the oven is required for use with both natural gas and propane. If the connected pressure exceeds 14.0" W.C. (3.48 kPa), a step-down regulator is required. A step-down regulator is not the responsibility of the manufacturer.

Use an approved pipe sealant at all connections. Do not use Teflon® tape. Gas supply connections and pipe joint compound must be resistant to the action of propane gases. Pipes must be clean, free of obstructions and pipe joint compound.

Gas Connection

In the U.S.A., installation must conform to local codes or, in the absence of local codes, with the current edition of the *National Fuel Gas Code*, NFPA-54 and ANSI Z223.1-1980 (latest edition). In Canada, installation must be in accordance with local codes, CAN/CGA-B149.1, *Installation for Natural Gas Burning Appliances and Equipment* (latest edition) or CAN/CGA-B149.2 *Installation for Propane Burning Appliances and Equipment* (latest edition).

The inlet supply line must be properly sized to accommodate all individual appliances simultaneously used on the same line but must never be smaller than 1/2" NPT.

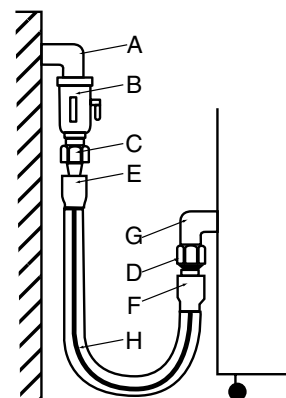
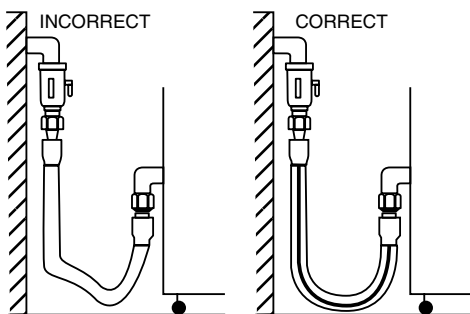

GAS INTAKE

- A-G Installation elbow
- B Ball Valve
- C-D Three-piece union fitting (minimum 1 per installation)
- E-F End connector for the flexible tube
- H Marking line

GAS SUPPLY & INSTALLATION

Gas Connection For Ovens On Casters

The oven must be supplied with a flexible connector that complies with *The Standard for Connectors for Movable Gas Appliances*, ANSI Z21.69, CGA 6.16 and addenda Z21.69a (latest editions). A quick disconnect device must be installed to comply with *The Standard for Quick Disconnect Devices for Use with Gas Fuel*, ANSI Z21.41 and CAN1-6.9 (latest editions). A flexible connector is not supplied by the factory.

Adequate means must be provided to limit the movement of the appliance. Limitation of movement must be made without depending on the connector, the quick disconnect device, or the associated piping designed to limit oven movement. Mounting holes for a restraining device are located on the lower back flange of the oven chassis.

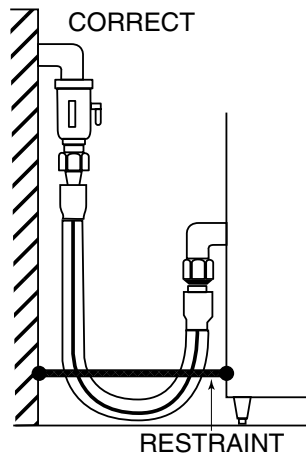

Shut the gas supply OFF if it becomes necessary to disconnect the restraint. Reconnect the restraint immediately following the return of the oven to its original position. Turn the gas supply ON after the restraint has been reconnected.

Leak Testing

Use a soap and water solution on all gas supply line connections.

WARNING



Never use an open flame or other ignition sources to check for gas leakage. Failure to do so may cause a fire or explosion and result in serious injury or death.

INSTALLATION

ELECTRICAL CONNECTION

This appliance is equipped with a three-prong grounding plug. For your protection against shock hazard this appliance should be plugged directly into a properly grounded three-prong receptacle. Do not cut or remove the grounding prong from this plug.

Plug the unit into a properly grounded receptacle **ONLY**, positioning the unit so that the plug is easily accessible in case of an emergency. Arcing will occur when connecting or disconnecting the unit unless all controls are in the **OFF** position.

Proper receptacle or outlet configuration or permanent wiring for this unit must be installed by a licensed electrician in accordance with applicable local electrical codes.

CAUTION



Power source must match voltage identified on appliance rating tag. The rating tag provides essential technical information required for any appliance installation, maintenance or repairs. Do not remove, damage or modify the rating tag.

WARNING



To prevent serious injury, death, or property damage:

All electrical connections must be made by a qualified and trained service technician in accordance with applicable electrical codes.

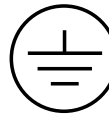

This appliance must be adequately grounded in accordance with local electrical codes or, in the absence of local codes, with the current edition of the National Electrical Code ANSI/NFPA No. 70. In Canada, all electrical connections are to be made in accordance with CSA C22.1, Canadian Electrical Code Part 1 or local codes.



CE-approved appliances include an equipotential-bonding terminal marked with the symbol shown on the left. Provisions for earthing are to be made in accordance with IEC:2010 60335-1 section 27 or local codes.

ELECTRICAL				
VOLTAGE	PHASE	CYCLE/HZ	AMPS	kW
120	1	60	7.5	0.9
9' (2743mm) cord with plug included: NEMA 5-15P 				

INSTALLATION

VENTILATION

WARNING



Failure to properly vent this appliance may cause **SERIOUS INJURY, DEATH, or PROPERTY DAMAGE**. The formation of volatile substances may cause suffocation, equipment damage, operational problems and unsatisfactory cooking performance as a consequence of improper venting and is not covered by your warranty.

Ventilation Hoods

Proper venting along with a sufficient quantity of make-up air is essential for proper oven operation. A mechanically driven, canopy exhaust hood is the preferred method of ventilation and must conform to local codes along with the current version of NFPA-96 *Vapor Removal from Cooking Equipment* (latest edition). The oven hood must extend 6" (152mm) beyond all sides of the oven. The distance from the floor to the bottom edge of the hood should be between 6' (1829mm) and 7' (2134mm).

A ventilation hood that supplies make-up air down the back vertical wall should be avoided since air currents can interfere with the oven flue exits. If such installation is unavoidable, an additional draft hood, specifically designed to deflect downdrafts, must be installed.

Ventilation hoods and exhaust systems shall be permitted to be used to vent appliances installed in commercial applications.

In accordance with NFPA 54 for the Commonwealth of Massachusetts only:

Where automatically operated appliances are vented through a ventilation hood or exhaust system equipped with a damper or with a power means of exhaust, provisions shall be made to allow the flow of gas to the main burners only when the damper is open to a position to properly vent the appliance and when the power means of exhaust is in operation.

Direct Venting

When necessary, direct venting can be used in situations where space is limited or to help offset the high cost of ventilation hoods.

WARNING



To prevent **SERIOUS INJURY, DEATH, or PROPERTY DAMAGE**:

Installation, air adjustment and/or service work must be in accordance with all local codes and must be performed by a trained service technician qualified to work on gas appliances.

Direct venting should be installed in compliance with local codes by a certified professional. In the absence of local codes, refer to National Fuel Code NFPA 54, ANSI Z223.1 (latest revision).

INSTALLATION

STACKING KIT (5005783)

Stacking Instructions

- A) Remove side panels.
- B) Knock out the mounting holes on top of the intended bottom oven.
- C) After legs or casters have been installed on the bottom oven, place the upper oven on top of lower unit. Align.
- D) Bolt at 1 and 2.
- E) Using mounting holes on bottom oven, bolt at 4.

ITEM	DESCRIPTION	PART NO.	QTY
1	BRACKET, ATTACHMENT, FSCO	1004369	2
2	SCREW, #10 SMS .5LG	SC-26520	20
3	SCREW, HEX HEAD, 5/16-18X 1"LG	SC-2191	2
4	5/16 FLAT WASHER	WS-23725	2
5	WASHER, LOCK, 5/16 DIA.	WS-2867	2

Note: Actual unit may be different than shown.

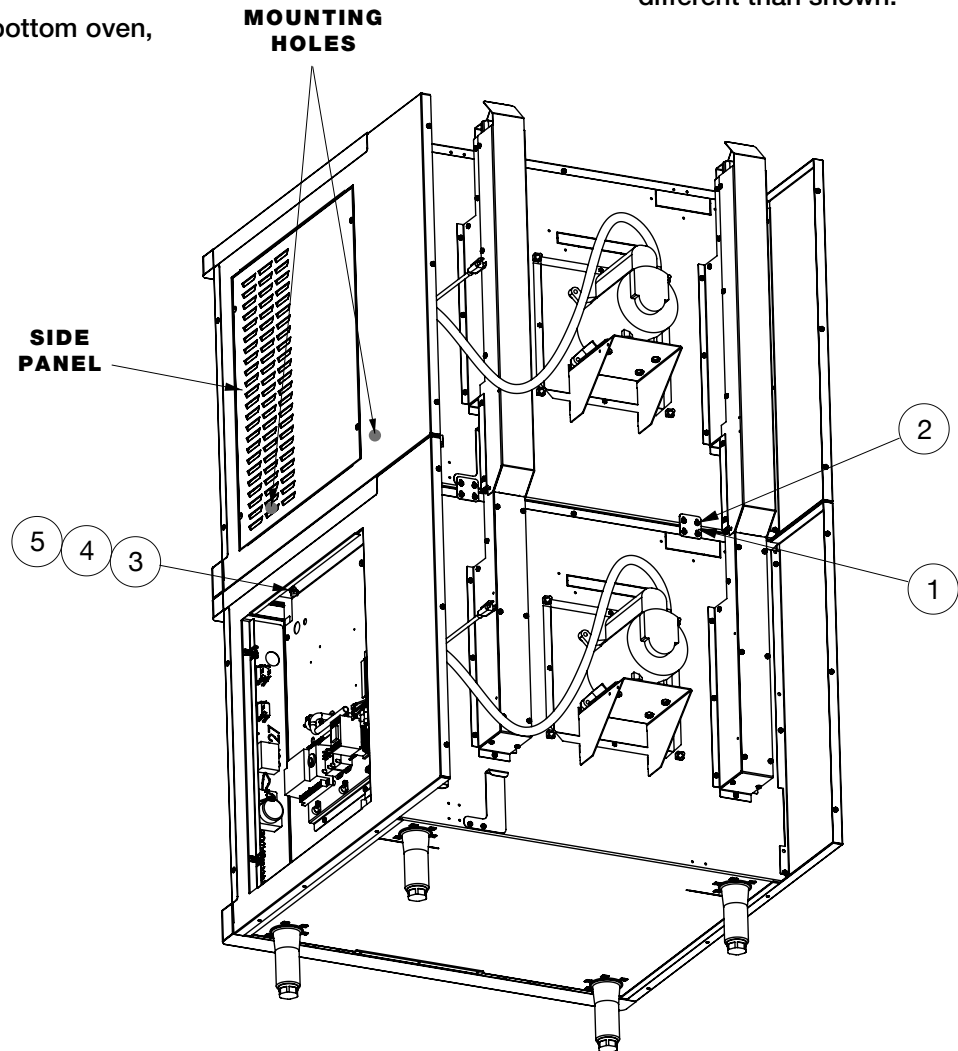

CAUTION



Appliance and accessories may be heavy. To prevent serious injury, **always** use a sufficient number of trained and experienced workers when moving or leveling appliance and handling accessories.

Rev 07/14

INSTALLATION

STACKING, GAS PLUMBING & FLUE INTERCONNECT (5003788)

Assembly Instructions

1: Assemble plumbing items 3-4 and 6-8 as shown

2: Assemble items 1, 2 & 5 as shown

ITEM	DESCRIPTION	PART NO.	QTY
1	OUTER FLUE BOX, DBL STACK	1004372	2
2	SCREW, #10 SMS .5LG	SC-26520	24
3	ELBOW 90 DEG STREET 3/4" NPT	EB-26489	1
4	FITTING, UNION 3/4" NPT	FT-26488	1
5	CAP, FLUE BOX, DBL STACK	1004373	2
6	3/4" MANIFOLD PIPE	PP-26529	1
7	FITTING, TEE 3/4" NPT	FT-26487	1
8	3/4" MANIFOLD PIPE	PP-26528	1
9*	BUSHING	BU-26440	2

* NOT SHOWN

Note: Actual unit may be different than shown.

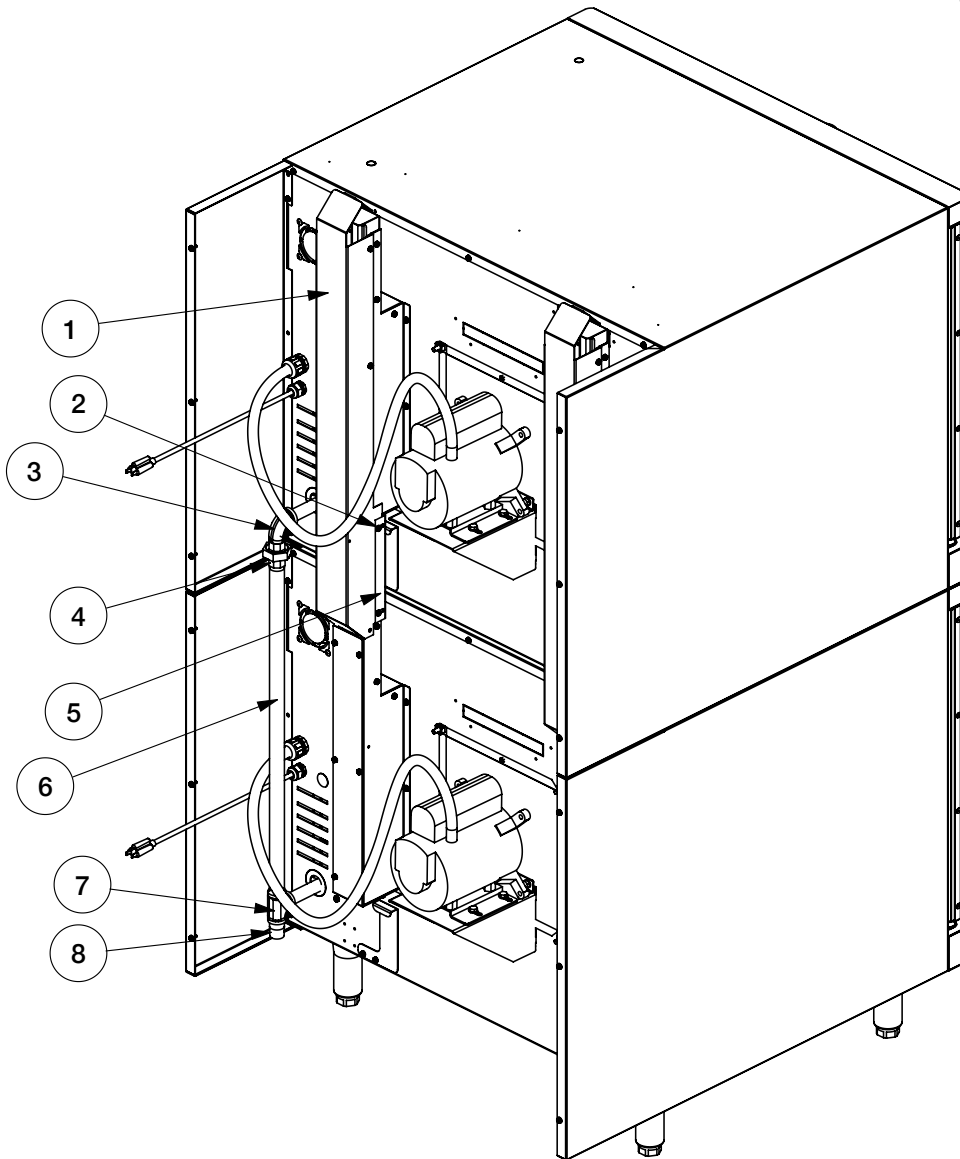

Rev 07/14

Part numbers and drawings are subject to change without notice.

INSTALLATION

Oven Stand Assembly

Oven stand **5003489** shown

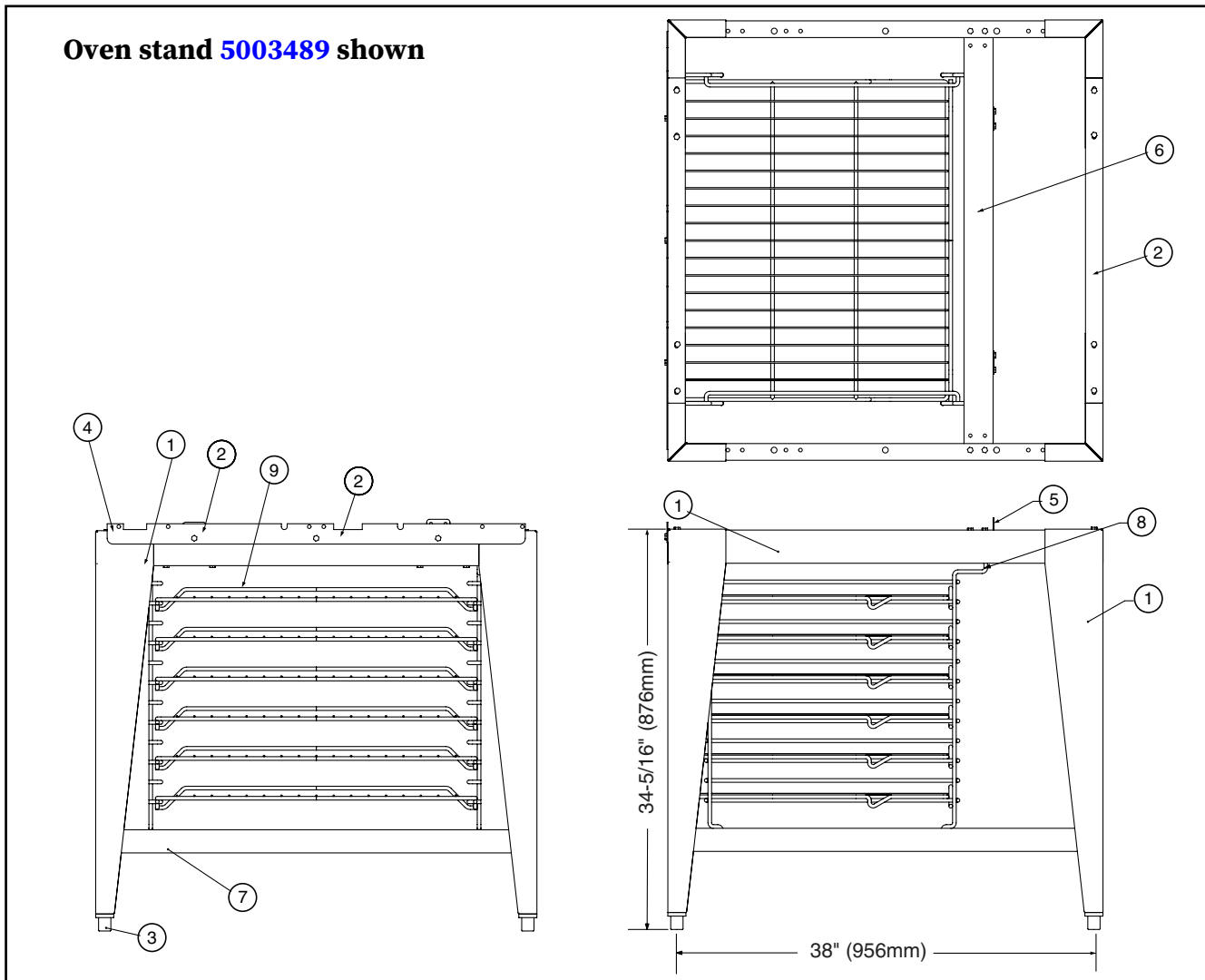

Item	Description	Part No.	Qty
1	Leg Support Assembly	5003488	2
2	Channel, Support	1004459	2
3	Leg	LG-22185	4
*	Casters, Rigid	CS-25674	2
*	Casters, Swivel W/Brake	CS-25675	2
4	Bracket, Stand	1004461	1
5	Bracket, Attachment	1004369	2
6	Channel, Back	1004460	1
7	Shelf, Stand	1004466	1
8	Rack, Oven Support	SR-26551	2
9	Oven Rack	SH-26795	6
10*	Screws, 1/4-20 X 1/2 Hex Head	SC-22729	27
11*	Nut, 1/4-20 Nylon Insert, 18-8 S/S	NU-23984	27
128	Lock Washer, 1/4" Stainless Steel	WS-2294	27

*Not shown

Part numbers and drawings are subject to change without notice.

OPERATING INSTRUCTIONS

USER SAFETY INFORMATION



CAUTION



To prevent **personal injury** or **property damage**:

Always use hand protection when operating this appliance to avoid burns. Metal parts of this equipment become extremely hot when in operation.

The Platinum Series gas convection oven is intended for use in commercial establishments by qualified operating personnel where all operators are familiar with the purpose, limitations, and associated hazards of this appliance. Operating instructions and warnings must be read and understood by all operators and users.

Instructions to be followed in the event the odor of gas is detected should be posted in a prominent location. Specific instructions are available from your local gas supplier.

DANGER



Before starting the appliance, make certain you do not detect the odor of gas.

If you smell gas:

- Shut off the gas supply immediately.
- Do not attempt to light any appliance.
- Do not touch any electrical elements.
- Extinguish any open flame.
- Evacuate the area.
- Use a telephone outside the property and immediately contact your gas supplier.
- If unable to contact your gas supplier, contact the fire department.

FACTORY INSTALLED OPTIONS

Direct Vent Kit (TO VENT DIRECTLY TO OUTSIDE)
Increases height 8" (203mm)

- Single oven 5003797
- Stacked ovens 5012618

Stacking Hardware

See individual stacking combination specification sheets.

Security Device FOR CORRECTIONAL FACILITY USE

Includes security back panel, door locking hasp, security screw package, security control cover. 5020687

ACCESSORIES

- Caster Set, 6" (152mm)** 5003790
FOR MOBILE STACK APPLICATIONS

Leg Kit (4)

- 6" (152mm), with Bullet Feet 5003794
- 6" (152mm), with Seismic Feet 5003795
- 25" (635mm), with Seismic Feet 5003785

- Rear Enclosure Panel**, stainless steel 5005876

Shelf, Oven Rack

- Interchangeable with cooling rack SH-26795

Stand, Stainless Steel

- Mobile with Cooling Racks & Casters 5003786
- Stationary with Cooling Racks & Bullet Feet 5003489
- Stationary with Cooling Racks & Seismic Feet 5003787

In the event of a power failure:

- Turn all switches off.
- Wait until power is restored before attempting to operate the oven.

NOTICE: If such an event has occurred, it is strongly recommended that you ensure the food in the oven is safe for consumption according to local health regulations.

OPERATING INSTRUCTIONS

START-UP OPERATION

Before Initial Use:

Interior oven surfaces must be heated to remove surface oils and the accompanying odors produced during the first use of the oven.

1. Wipe all wire shelves, side racks, and the full oven interior with a clean, damp cloth.
2. Close the oven doors, press the power switch to the **ON** position, and set the thermostat to 300°F (149°C).
3. Allow the oven to cycle for approximately 2 hours, or until no odor is detected.

Preheating:

Always preheat the oven for a minimum of 20 minutes before cooking product. Follow the operating instructions indicated on the next page of this manual.

Pan/Shelf Positions:

The oven includes 6 chrome plated wire shelves with two removable side racks and 12 shelf positions spaced at 1-3/4" (43mm).

1. **POSITION** The best arrangement for broiling, baking cookies and for other baked goods under 2-1/2" (65mm) in height.
2
4
6
8
12
This arrangement can also be used as the maximum capacity for reconstituting frozen entrées.
2. **POSITION** General baking with the use of sheet pans for products under 3-1/2" (89mm) in height. Products include cakes, pies, muffins, or extended dishes in 12" x 20" x 2-1/2" deep pans (530mm x 325mm x 65mm GN 1/1).
1
4
7
10
3. **POSITION** Ideal positions for baking bread, meringue, or extended dishes and roasts in pans not to exceed 5-1/2" (140mm) in height.
1
5
9
4. **POSITION** Arrangement necessary for roasting whole turkey or roasts up to 7" (178mm) in height.
1
6

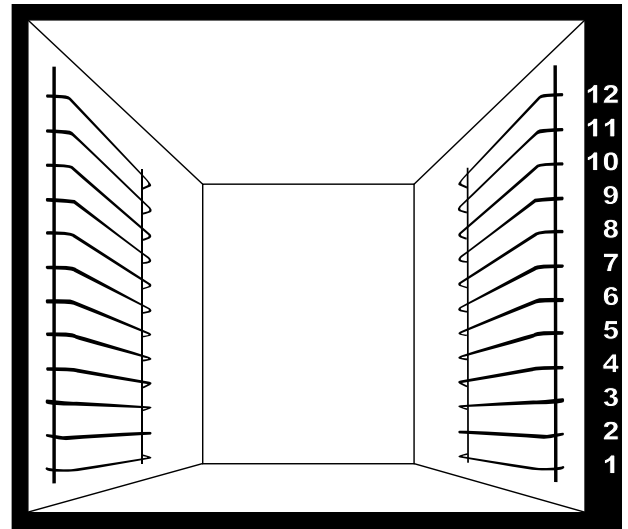

**CAUTION**

To prevent **personal injury** or **property damage**:



Always use hand protection when operating this appliance to avoid burns. Metal parts of this equipment become extremely hot when in operation.

OPERATING INSTRUCTIONS

CONTROL IDENTIFICATION

- 1** PREHEAT INDICATOR
- 2** READY INDICATOR
- 3** LED DISPLAY
- 4** UP/DOWN ARROWS
- 5** COOK INDICATOR
- 6** TEMPERATURE INDICATOR
- 7** PROBE INDICATOR
- 8** PRESET LOCK INDICATOR
- 9** COOK
- 10** PROBE
- 11** TIME
- 12** PRESET LOCK
- 13** START/STOP
- 14** PRESETS
- 15** CANCEL
- 16** FAN SPEED
- 17** COOL DOWN
- 18** MAIN POWER SWITCH

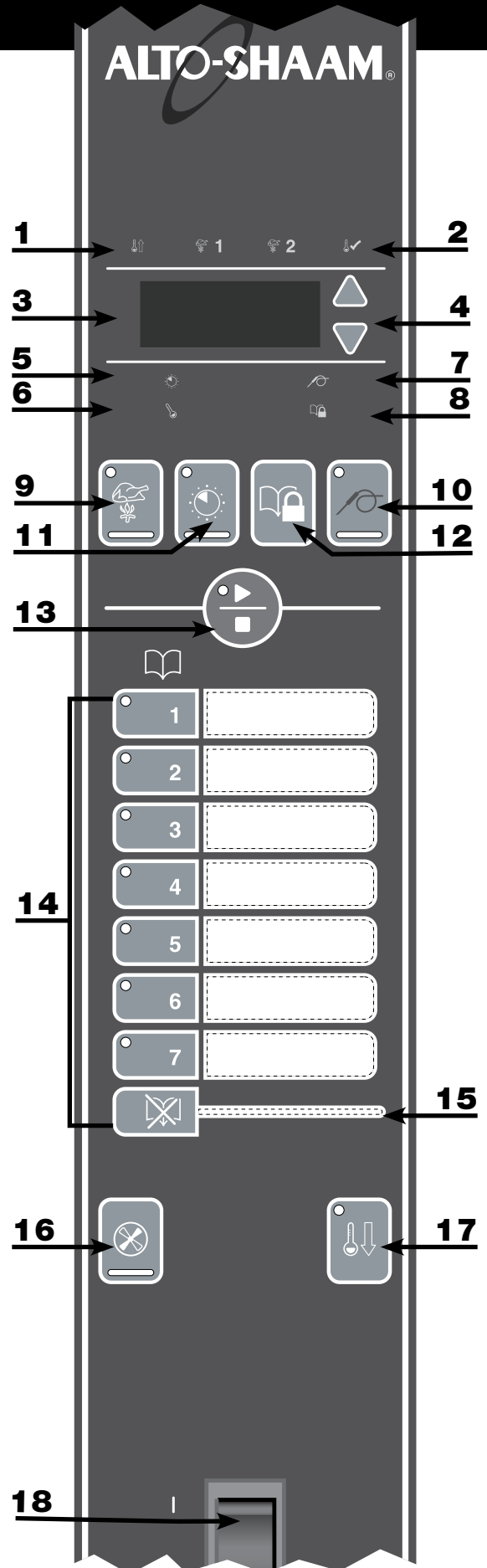

OPERATING INSTRUCTIONS

ELECTRONIC CONTROL OPERATION

A. Push MAIN POWER SWITCH (18) ON.

- The **DISPLAY (3)** will alternate between last cook set temperature and actual cavity temperature.
- The oven will preheat to previous cook temperature, and the **PREHEAT (1)** indicator will illuminate.

To terminate procedure,
push **START/STOP (13)** button twice.

B. If the previous cook cycle is acceptable, proceed to step C.

- **To cook by time:***
 - Push **COOK (9)**.
 - Push **TIME (11)**.
 - Confirm fan speed.
 - Adjust the cooking temperature with the **UP/DOWN (4)** arrows.
- **To cook by probe (optional):***
 - Push **COOK (9)**.
 - Push **PROBE (11)**.
 - Confirm fan speed.
 - Adjust the cooking temperature with the **UP/DOWN (4)** arrows.

C. When the cook preheat temperature has been reached:

- The **START/STOP (13)** button and **READY INDICATOR (2)** will flash.
- The control will produce an audible beep every 30 seconds.
- **Load product in a timely manner.**
 - **To cook by time:**
 - When cooking by **TIME (11)**, the **DISPLAY (3)** will alternate between cook temperature and remaining cooking time.

• To cook by probe (optional):

- If cooking by probe, remove probe from its bracket, wipe the probe tip with a disposable alcohol pad and properly insert probe into product.
- When cooking by **PROBE (11)**, the **DISPLAY (3)** will alternate between cook temperature, probe temperature, and elapsed time.

• Close the oven door — push START/STOP (13) button.

• After cook cycle is complete and product is ready:

- The **DISPLAY (3)** will indicate "DONE".
- The **START/STOP (13)** button and **READY INDICATOR (2)** will flash.
- The control will produce an audible beep every 30 seconds.

• Remove product promptly to avoid overcooking.

To terminate procedure,
push **START/STOP (13)** button twice.

D. Cooling the oven:

- Open door.
- Push **COOL DOWN (17)** button.
- **Cool continuously***
 - Fan will run continuously.
 - Shut off power to terminate.
- **Set cool down temperature***
 - Set desired cool down temperature with **UP/DOWN (4)** arrows. *The cool down temperature ranges from 80°F-450°F (27°C-232°C).*
 - Fan will run continuously.
 - When the desired cool down temperature is reached, **DISPLAY (3)** will indicate "DONE".

START/STOP (13) button will stop the fan and terminate the **COOL DOWN (17)** feature.

E. At the end of the day, shut off oven power before leaving the premises.

* If more than 5 seconds elapse before a decision is made, the mode button must be pushed again to continue.

OPERATING INSTRUCTIONS

MENU PRESETS

Programming

This Alto-Shaam electronic convection oven allows the operator to program up to seven cooking procedures. Each cooking program entered can be preset in any program function to cook by time (or probe, if a probe is included on the oven). Cooking programs are stored and recalled with the **PRESET (14)** buttons labeled 1 through 7.

Push the **MAIN POWER SWITCH (18) ON**.

- The **DISPLAY (3)** will alternate between last cook set temperature and actual cavity temperature. The oven will begin preheating and the **PREHEAT (1)** indicator will illuminate. The fan will operate at high speed "FnHi".

FOLLOW INSTRUCTIONS LISTED ON THE PREVIOUS PAGES OF THIS MANUAL.

Push and hold selected **PRESET (1 through 7)** for 4 seconds.

- A beep sounds.
- The numbered button indicator light will illuminate.

The programmed procedure is now stored in memory for the specific number button selected. To lock a **PRESET (14)** (1 through 7), push **PRESET LOCK (12)** simultaneously with up arrow. To unlock, push **PRESET LOCK (12)** simultaneously with the down arrow.

At this point, push **START/STOP (13)** twice. This will protect the **PRESET (14)** in case of a power outage.

Important

After programming a specific product into memory of a preset, it is very important to make a written permanent record of the product and the program letter assigned.

Erasing A Program

To erase a program, the oven must be in the preheat mode. The oven cannot be running a preset menu program.

- When the oven is in the preheat mode, push and hold both the **CANCEL (15)** button and the appropriate number **PRESET (14)** button to be erased. Hold both buttons until the oven beeps for one second and the program's indicator light goes out. This indicates the program has been erased.

Cook — Using Preset Menu Buttons

- Push desired **PRESET (14)** (1 through 7). Preheat will begin.
- The oven will beep when the preheat temperature has been reached.
- Load food inside the oven. *If cooking by probe, remove probe from its bracket, wipe the tip with a disposable alcohol pad and insert probe properly into product.*
- Close the oven door.
- Push **START (13)**.

- NOTICE:**
- If the oven temperature is higher than the **PRESET** program, utilize the **COOL DOWN** mode.
 - Time and Temperature have been programmed in **PRESET** -- they cannot be adjusted during the **PRESET** cooking cycle.

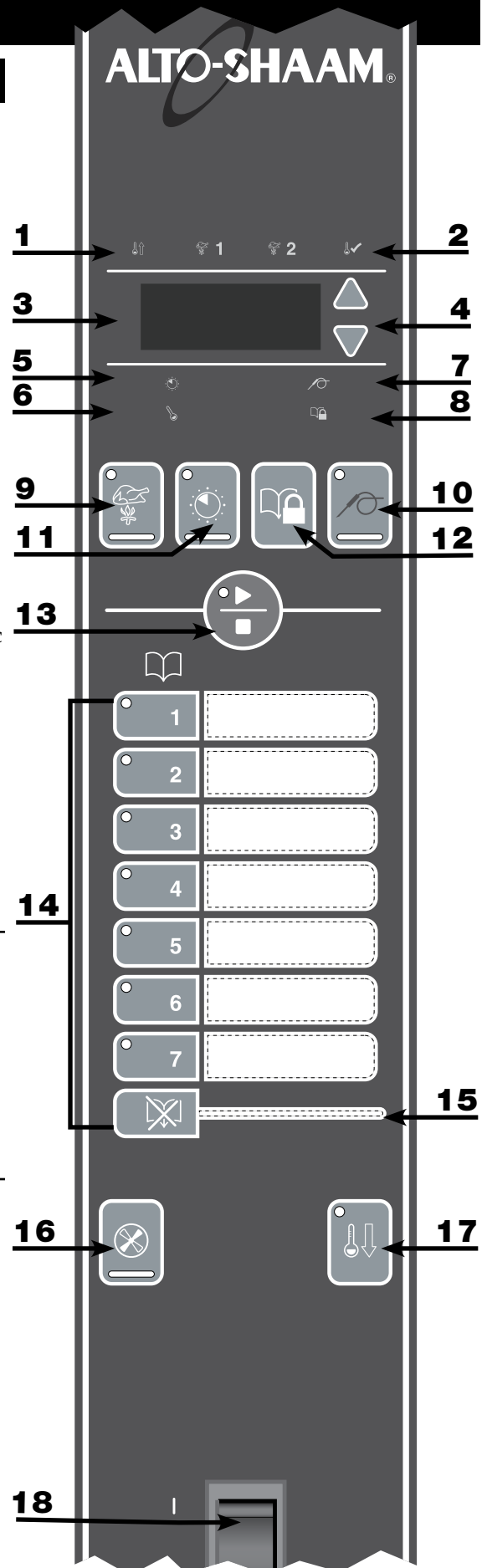

OPERATING INSTRUCTIONS

Stop an Operation:

Push **START/STOP (13)** button. The oven will remain in a power-on state, and the operation will be cancelled. Push **COOK (9)** to set procedure again.

Adding product after Start:

If the door is opened during cook cycle, the heater, fan, and timer will disengage. "Door" will illuminate in the display. The timer will be held to the last value at the point of interruption. The oven will continue operation from the point of interruption when the door is closed.

Arrows:

COOK (9) and **PROBE (10)** temperature settings can be adjusted by pushing the up/down arrows. Pushing and releasing the arrow button will change the setting in increments of one. To change a setting more rapidly, push and hold the up/down arrows. Once the setting reaches a number divisible by 10, it will begin to increase in increments of 10.

The **TIME (11)** setting is adjusted in increments of 1 minute by pushing the arrow buttons. To make adjustment in steps of 10 minutes, push and hold the arrow button. Once the setting reaches a number divisible by 10, it will begin to increase in increments of 10.

To Run Oven Continuously at a Set Temperature:

Set **COOK (9)** temperature, set **TIME (11)** to "--:--". The oven will run continuously at that set temperature. The display will alternate between the set temperature and "--:--", signifying continuous cooking. The operator is then responsible for timing the cooking loads. To disengage, push **START/STOP (13)**.

Fan Speed:

The fan speed can be adjusted to high or low during any **PREHEAT (1)** or **COOK (9)** cycle (including **PRESETS (12)**). When high speed is selected, the underscore bar below the **FAN SPEED (16)** button will illuminate. The display will indicate "FnHi". When low speed is selected, the underscore bar below the **FAN SPEED (16)** button will not be illuminated. The display will indicate "FnLo".

NOTE: The time and temperature can be adjusted during the cooking mode, unless a preset program is used.

Probe Usage:

When the oven probe remains inserted in the probe bracket, the LED temperature display will indicate the ambient air temperature inside the oven. To use the probe for cooking remove it from the bracket and wipe the full length of the metal probe with a disposable alcohol pad to clean and sanitize before using.

Only the tip of the probe senses the internal product temperature; therefore, it is important the tip be placed correctly in the product for internal temperature accuracy. Push the probe tip halfway into the product, positioning the tip at the center of the food mass. When inserting the probe into solid foods, such as meat roast or poultry breasts, push the probe in from a straight downward position or in from the side to the center position. If placing into a semi-liquid or liquid product, the probe cable must be secured to keep the probe positioned properly. Do not let the probe tip touch the edges, bottom or side of a container. Tape the probe cable to the lip or edge of the container.

NOTICE: When cooking by probe, insert the probe into the raw product after the oven has been preheated.

Wait one full minute to allow the probe temperature to decrease to the internal temperature of the product. Push the start button to begin the cooking process after this probe temperature adjustment period. A false probe reading of the internal product temperature will cause the oven to default to a holding temperature.

Probe Calibration:

1. To verify product probe calibration, place the probe in a warm glass of water along with a quality independent digital thermometer and push the probe button for two (2) seconds to display the probes actual temperature. Compare readings.
2. If calibration is required, push the probe button for eight (8) seconds until the unit beeps twice and the probe offset is displayed. Adjust the probe offset to match the difference between the independent probe temperature and the control probe temperature by pushing the up or down arrows to increase or decrease the offset.
3. Repeat steps 1 and 2 to verify the probe calibration as necessary.

CHEF OPERATING TIPS

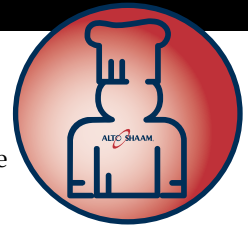

The Alto-Shaam convection oven will provide the best results and longest possible service with the utilization of the following suggestions and guidelines.

NOTICE: Moisture will escape around the doors when baking products with a heavy moisture content such as chicken, potatoes, etc. This is a normal operating condition.

1. Thoroughly preheat the oven for approximately 20 minutes before use.
2. As a general rule, the cooking temperature can be set lower than the temperature used in a conventional oven. Cooking time may also be shorter. It is suggested the first batch of each product prepared be monitored closely to check for variances.
3. Maintain a record of the temperatures, times, and load capacities established for products cooked on a regular basis since they will be the same or similar for succeeding loads.
4. When practical, start cooking the lowest temperature products first and gradually work up to products with a higher cooking temperature.
5. If the cooking temperature setting for the previous product is more than 10°F (5°C to 6°C) higher than the temperature needed for the next load, use the FAN COOL DOWN feature to decrease the oven temperature before setting the oven to a lower temperature.
6. Work as quickly as possible when loading the oven to prevent heat loss.
7. When the audible signal indicates the time has expired, remove the food product from the oven as quickly as possible to avoid overcooking.
8. Pans should be centered between side racks and each shelf should be loaded evenly to allow proper air circulation within the oven compartment.
9. To ensure even cooking when baking, weigh or measure the product in each pan.
10. When cooking six pans of product, start from the top of the oven and use side rack positions 2, 4, 6, 8, 10, and 12.
11. Do not overload the oven. A maximum 6 sheet pan capacity is suggested for most items such as cakes, cookies, rolls, etc. A maximum of 12 sheet pans may be used for items such as fish sticks, chicken nuggets, and hamburgers. It will be necessary to adjust cooking times accordingly. Refer to product/pan capacities indicated in this manual.
12. To obtain an evenly baked product, muffin pans should be placed in the oven with the short side of each pan facing the front of the oven.
13. When rethermalizing frozen casseroles, preheat the oven 100°F (38°C) over the suggested temperature to compensate for the introduction of a large quantity of frozen product into the oven compartment. Reset the thermostat to the correct cooking temperature after the oven is loaded.
14. Use a pan extender or 2" (51mm) deep, 18" x 26", pan for batter-type products that weigh more than 8 lbs (3 to 4 kg), i.e. pineapple upside-down cake.
15. To avoid obstructing airflow that would result in uneven cooking results, never place anything directly on the bottom of the oven cavity.

Cooking Guidelines							
Food	Temperature		Time (Minutes)	Food	Temperature		Time (Minutes)
Cakes, Sheet	325°F	163°C	25	Macaroni & Cheese (FROZEN, FULL OVEN)	350°F	177°C	90
Chicken pieces (30 BREASTS & THIGHS, 25 LEGS & WINGS)	400°F	204°C	25	Macaroni & Cheese (REFRIGERATED)	350°F	177°C	30
Chicken halves	400°F	204°C	40	Muffins	325°F	163°C	13-15
Beef patties	400°F	204°C	8	Pies, Frozen	325°F	163°C	40
Bacon	350°F	177°C	16	Pizzas, Individual	325°F	163°C	15
Fish, frozen (5 OZ.)	350°F	177°C	15	Potatoes, Baked	350°F	177°C	50
Macaroni & Cheese (FROZEN, 1 PAN)	350°F	177°C	50	Sandwiches, Grilled Cheese	400°F	204°C	4-6
				Tater tots	450°F	232°C	10

AT THE END OF THE DAY, UTILIZE THE COOL-DOWN MODE AND OPEN THE OVEN DOORS.

Do not place anything directly on the bottom of the oven cavity.

CARE AND CLEANING

Protecting Stainless Steel Surfaces



It is important to guard against corrosion in the care of stainless steel surfaces. Harsh, corrosive, or inappropriate chemicals can completely destroy the protective surface layer of stainless steel. Abrasive pads, steel wool, or metal implements

will abrade surfaces causing damage to this protective coating and will eventually result in areas of corrosion. Even water, particularly hard water that contains high to moderate concentrations of chloride, will cause oxidation and pitting that result in rust and corrosion. In addition, many acidic foods spilled and left to remain on metal surfaces are contributing factors that will corrode surfaces.

Proper cleaning agents, materials, and methods are vital to maintaining the appearance and life of this appliance. Spilled foods should be removed and the area wiped as soon as possible but at the very least, a minimum of once per day. Always thoroughly rinse surfaces after using a cleaning agent and wipe standing water as quickly as possible after rinsing.

Cleaning Agents

Use non-abrasive cleaning products designed for use on stainless steel surfaces. Cleaning agents must be chloride-free compounds and must not contain quaternary salts. Never use hydrochloric acid (muriatic acid) on stainless steel surfaces. Failure to observe this precaution will void the warranty. Always use the proper cleaning agent at the manufacturer's recommended strength. Contact your local cleaning supplier for product recommendations.

Cleaning Materials

Cleaning can usually be accomplished with the proper cleaning agent and a soft, clean cloth. When more aggressive methods are needed, use a non-abrasive scouring pad on difficult areas and make certain to scrub with the visible grain of surface metal to avoid surface scratches. Never use wire brushes, metal scouring pads, or scrapers to remove food residue. Failure to observe this precaution will void the warranty.

NOTICE



To protect stainless steel surfaces, completely avoid the use of abrasive cleaning compounds, chloride based cleaners, or cleaners containing quaternary salts. **Never** use hydrochloric acid (muriatic acid) on stainless steel. **Never** use wire brushes, metal scouring pads or scrapers.

! WARNING



To prevent **serious personal injury, death, or property damage:**

The appliance must be cleaned thoroughly to avoid deposits of grease and or food residue inside the appliance that may catch fire. If fat deposits and/or food waste inside the appliance ignite, shut down the appliance immediately and keep the appliance door closed to extinguish the fire. If further extinguishing is required, disconnect the appliance from the main power and use a fire extinguisher (do not use water to extinguish a grease fire!). Failure to clean the appliance properly invalidates the warranty and relieves Alto-Shaam of all liability.

CARE AND CLEANING

WARNING



To prevent serious personal injury, death, or property damage:

Do not steam clean, hose down or flood the interior or exterior with water or liquid solution of any kind. **Do not** use water jet to clean. Failure to observe this precaution will void the warranty.

The oven is fabricated with an easy to clean porcelain enamel interior or an optional stainless steel interior.

NOTICE: Always allow the oven to cool before cleaning. If the oven is hot, allow the interior surfaces to become cool to the touch by opening the oven doors and engaging the cool down function.

Do not use abrasive cleaning compounds.

Completely avoid the use of abrasive cleaning compounds, chloride-based cleaners, or cleaners containing quaternary salts. To protect metal finish on stainless steel, never use hydrochloric acid (muriatic acid).

Clean The Oven On A Daily Basis

1. After the oven has cooled, remove all detachable items such as wire shelves, side racks, and drip pan. Clean these items separately.
2. Remove any food scraps from shelves, shelf supports, and blower fan wheel. Convection baffle openings must be kept clear of food scraps and grease.
3. Wipe the interior metal surfaces of the oven with a paper towel to remove any remaining food debris.
4. Clean interior with a damp cloth or sponge and any good commercial detergent at the recommended strength.
5. For baked-on food deposits, use a non-caustic and non-toxic commercial oven cleaner appropriate for the interior oven surface of your oven. Follow the product manufacturer's instructions carefully for the use of this product. Any commercial oven cleaner must be approved for use on food contact areas. Remove soil with the use of a plastic scouring pad.

WARNING

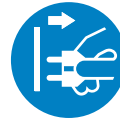

To prevent serious injury, death, or property damage, **always** disconnect the appliance from the power source before cleaning or servicing.

6. Wipe door gaskets thoroughly since these areas harbor food debris and grease.
7. Rinse surfaces by wiping with a clean cloth or sponge and clean warm water.
8. Remove excess water with a sponge and wipe dry with a clean cloth or air dry. Leave doors open until interior is completely dry. Replace side racks and shelves.

Always follow appropriate state or local health (hygiene) regulations regarding all applicable cleaning and sanitation requirements for food service equipment.

Exterior

To help maintain the protective film coating on polished stainless steel, clean the exterior of the cabinet with a cleaner recommended for stainless steel surfaces. Spray the cleaning agent on a clean cloth and wipe with the grain of the stainless steel.

Wipe control panel, door vents and door handles, thoroughly since these areas harbor food debris.

Clean exterior glass surfaces with a commercial window cleaner.

Do not use abrasive cleaning compounds

Motor Care

The convection oven motor contains self-lubricating, sealed ball bearings and is generally maintenance-free. During operation, the interior of the motor is cooled by air flowing into the rear of the motor case. This is a general operating feature when proper clearances have been allowed.

At the end of the day, utilize the cool-down mode and open the oven doors.

TROUBLESHOOTING GUIDE

Code	Description	Possible Causes
E-10	Cavity air sensor shorted	Cavity air sensor reading < 5°F (-15°C). Verify sensor integrity.
E-11	Cavity air sensor open	Cavity air sensor reading > 517°F (269°C). Verify sensor integrity.
E-20	Product probe is shorted <i>Oven will cook in time only</i>	Product probe reading < 5°F (-15°C). Verify sensor integrity.
E-21	Product probe is open <i>Oven will cook in time only</i>	Product Probe reading > 517°F (269°C). Verify sensor integrity.
E-30	Under temperature	Unit has been more than 25°F (14°C) below set point for longer than 90 minutes.
E-31	Over temperature	Unit has been more than 60°F (33°C) above the maximum set-point for longer than 3 minutes. Holding Cabinets with this error code are more than 145°F (81°C) above the maximum set-point.
E-32	Safety switch open (Aux hi-limit switch)	Contact factory.
E-38	Internal software error	Contact factory.
E-39	Sensor error	Contact factory.
E-50	Temp. measurement error	Contact factory.
E-51	Temp. measurement error	Contact factory.
E-60	Real time clock error	Data set to factory default. Ensure that date and time are correct if applicable.
E-61	Real time clock error	Contact factory.
E-64	Clock is not oscillating	Contact factory.
E-70	Configuration connector error (DIP switch)	Refer to wiring diagram for the particular model and ensure dip switches on the control match the settings called out on the WD. If the dip switch settings are correct according to the print replace the control.
E-78	Voltage low	Voltage below 90 VAC on a 125 VAC unit, or below 190 VAC on a 208-240 VAC unit. Correct voltage.
E-79	Voltage high	Voltage over 135 VAC on a 125 VAC unit, or over 250 VAC on a 208-240 VAC unit. Correct voltage.
E-80	EEPROM Error	Ensure that all temperatures and times are properly set. Contact factory if problem persists.
E-81	EEPROM Error	Contact factory.
E-82	EEPROM Error	Contact factory.
E-83	EEPROM Error	Contact factory.
E-85	EEPROM Error	All timers, if previously on, are now off. Possible bad EEPROM.
E-86	EEPROM Error	Stored HACCP memory corrupted. HACCP Address reset to 1. Possible bad EEPROM. Contact factory if problem persists.
E-87	EEPROM Error	Stored offsets corrupted. Offsets reset to 0. Control may need a recalibration. Possible bad EEPROM. Contact factory if problem persists.
E-88	EEPROM Error	All timer set-points are reset to 1 minute. Timers, if previously on, are now off. Possible bad EEPROM.
E-90	Button stuck	A button has been held down for > 60 seconds. Adjust control. Error will reset when the problem has been resolved.
E-91	Input failure	Contact factory.
E-dS	Datakey error	Datakey digital signature incompatible. Cycle power, and install compatible Datakey if error persists.
E-dT	Datakey error	Datakey incompatible with control. Install compatible Datakey.
E-dU	Datakey unplugged	Install Datakey and cycle power to control to clear error.
dLto	Datalogger has timed out	Cycle power. Contact factory if error persists.
dLSD	Micro SD card not plugged in	Plug in SD card and cycle power. Contact factory if error persists.
NOTE: If in doubt, always cycle the power to the control and contact factory if the problem persists.		

FULL ASSEMBLY - ASC-4G

9 CONTROL ASSEMBLY

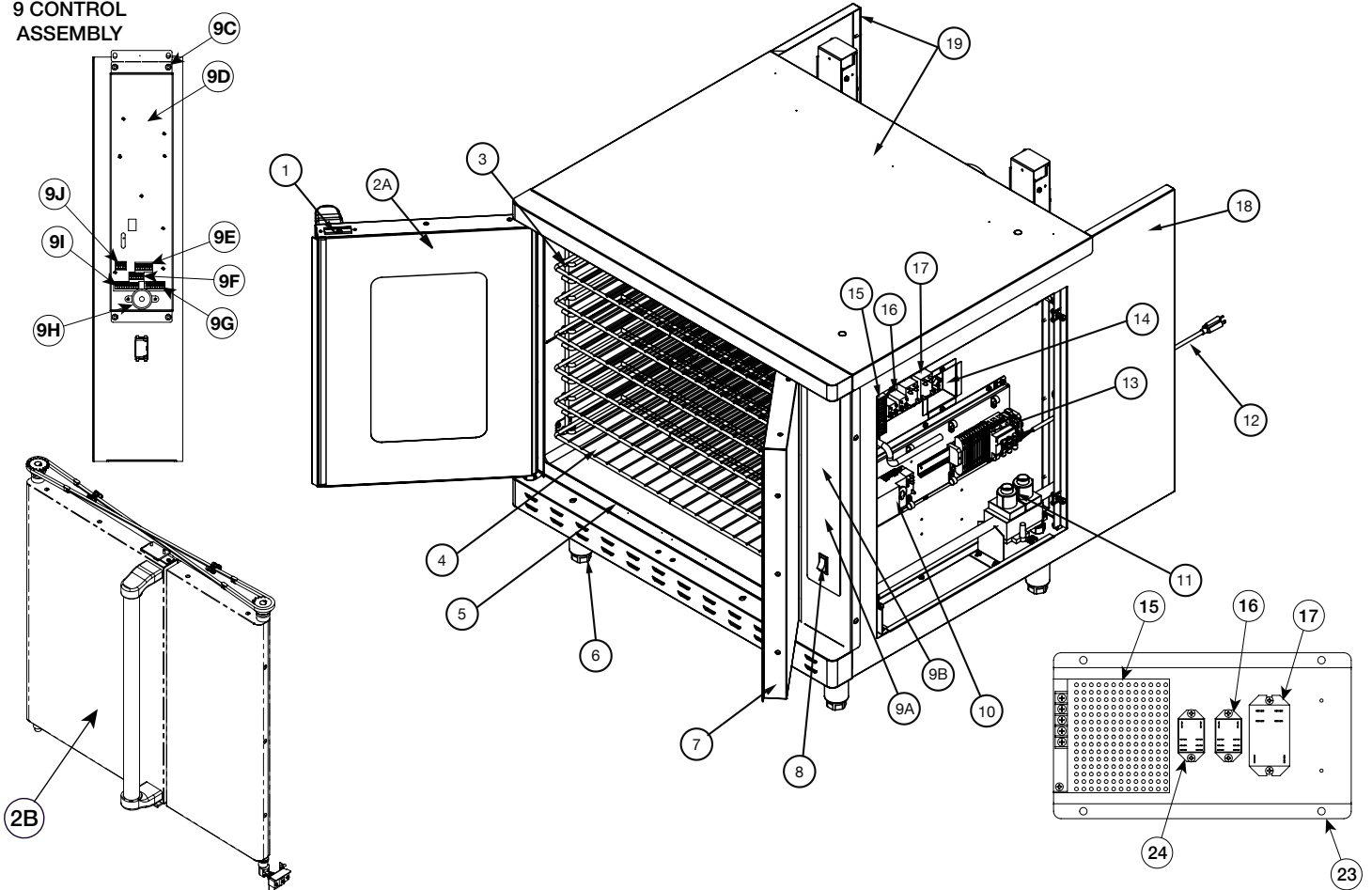

ITEM	DESCRIPTION	PART NO.	QTY	ITEM	DESCRIPTION	PART NO.	QTY
1	LATCH	LT-26976	2	10	IGNITION CONTROL W/ SENSOR	5010046	1
2A	DOOR ASSEMBLY, LH WINDOW	DR-27850	1	11	SOLENOIDS VALVES	VA-28189	2
2B	DOOR ASSEMBLY, LH SOLID	DR-36068	1	12	CORD	CD-34094	1
3	SIDE RACK	SR-26396	2	13	ELEC CHASSIS ASSY CHASSIS ASSY NEXT PAGE		1
4	OVEN RACK	SH-26795	6		TERMINAL BLOCK-1, TB-2, TB-3	TM-34307	6
5	GASKET	1000605	2		TERMINAL BLOCK-4	TM-34308	4
	TOP/BOTTOM	1000605	2		TERMINAL BLOCK-5	TM-34306	1
	SIDE	1000605	2	14	HIGH LIMIT	SW-34150	1
6	LEG	SEE PG 13	4	15	BOARD, POWER SUPPLY, 12V 50W	BA-36144	1
7	DOOR ASSEMBLY, RH	DR-27849	1	16	LIGHT RELAY, IGNITION RELAY	RL-33930	2
8	SWITCH, POWER	SW-34101	1	17	MOTOR RELAY, POWER	RL-34434	1
9A	PANEL OVERLAY	PE-26977	1	18	PANEL OUTER, RH	1006671	1
9B	CONTROL	5005350	1	19	PANEL OUTER, TOP AND LH	1006623	1
9C	NUT, #8-32 UNC KEPS ZP	NU-26526	4	20*	PANEL, LOUVERED ACCESS	1006672	1
9D	ASSEMBLY, CONTROLS, ELECTRIC	FW-37114	1	21*	COVER, BOTTOM	1006678	1
9E	CONNECTOR, 7 PIN	CR-33761	1	22*	FAN, BOX 3" 34CFM, 125V, 50-60Hz	FA-3973	1
9F	CONNECTOR, 6 PIN	CR-33762	1		FAN, BOX 4-11/16" 70CFM, 125V, 50-60Hz	FA-3599	1
9G	CONNECTORY, 8 PIN	CR-33719	1	23	BRACKET, MOUNTING	1006660	1
9H	BEEPER, SOLID STATE, 1.5-20V	BP-3567	1	24	SCREW 6-32 x 1/4" PAN HD	SC-22500	8
9I	CONNECTOR, 10 PIN, PLUGGABLE	CR-33717	1				
9J	CONNECTOR, 4 PIN	CR-33763	1				

*Not Shown

Part numbers and drawings are subject to change without notice.

ELECTRICAL CHASSIS ASSEMBLY - ASC-4G 120V 1PH

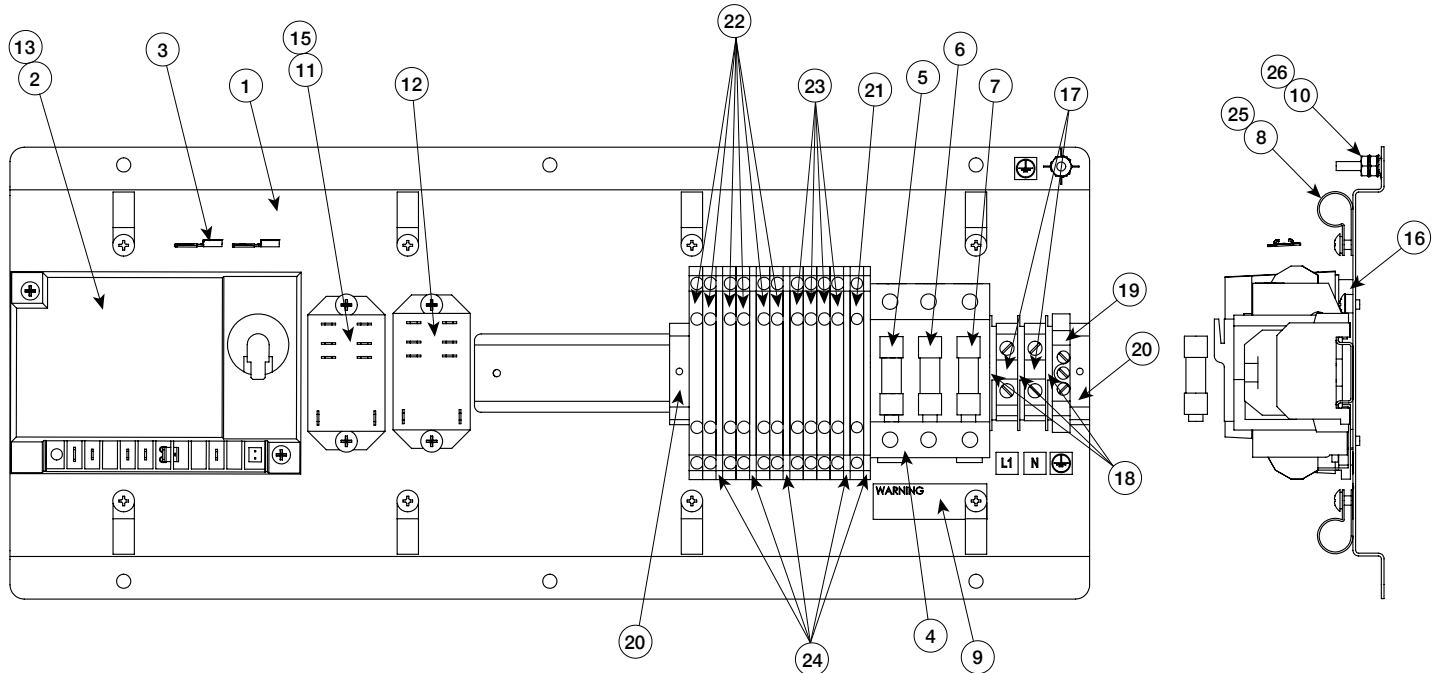

ITEM	DESCRIPTION	PART NO.	QTY
1	WELD, ASSY, ELEC CHAS BRACKET	1015418	1
2	CONTROL MODULE	CC-34088	1
3	CONNECTOR	CR-34559	2
4	FUSE HOLDER, 3 BANK	FU-34770	1
5	FUSE, 15 AMP	FU-34772	1
6	FUSE, 30 AMP	FU-34773	1
7	FUSE, 8 AMP	FU-35475	1
8	HOLDER, 1/2", OD PIPE	HL-27774	8
9	LABEL, FUSE REPLACEMENT	LA-36711	1
10	NUT, 10-32 UNF HEX MS, 18-8 SST	NU-2215	2
11	RELAY, POWER, DPDT, 30A, 12VDC, 277VA	RL-36452	1
12	RELAY, POWER, DPDT, 30A, 12VDC, 277VA	RL-37113	1
13	SCREW, 8-32 x 5/8" PAN	SC-2077	2
14	SCREW, 8-32 x 1/4" PHIL	SC-2459	8
15	SCREW, 8-32 x 1/4" TRH	SC-2459	4
16	SPACER	SP-26418	2
17	TERMINAL BLOCK	TM-3779	2
18	PARTITION	TM-3785	3
19	TERMINAL, GROUND	TM-3932	1
20	TERMINAL, SCREWLESS END	TM-34305	2
21	TERMINAL, GROUND, 6mm, SPRING	TM-34306	1
22	TERMINAL, 6mm, ORANGE, SPRING	TM-34307	6
23	TERMINAL, 6mm, BLUE, SPRING	TM-34308	4
24	TERMINAL, END SECTION, SPRING	TM-34309	5
25	WASHER, #8, LOCK WASHER	WS-27045	8
26	WASHER, #10 EXT LOCK	WS-29007	2
27*	CONNECTOR, DUAL SPADE, 1/4"	CR-3849	1

*Not Shown

Part numbers and drawings are subject to change without notice.

SERVICE

INTERIOR OVEN COMPARTMENT

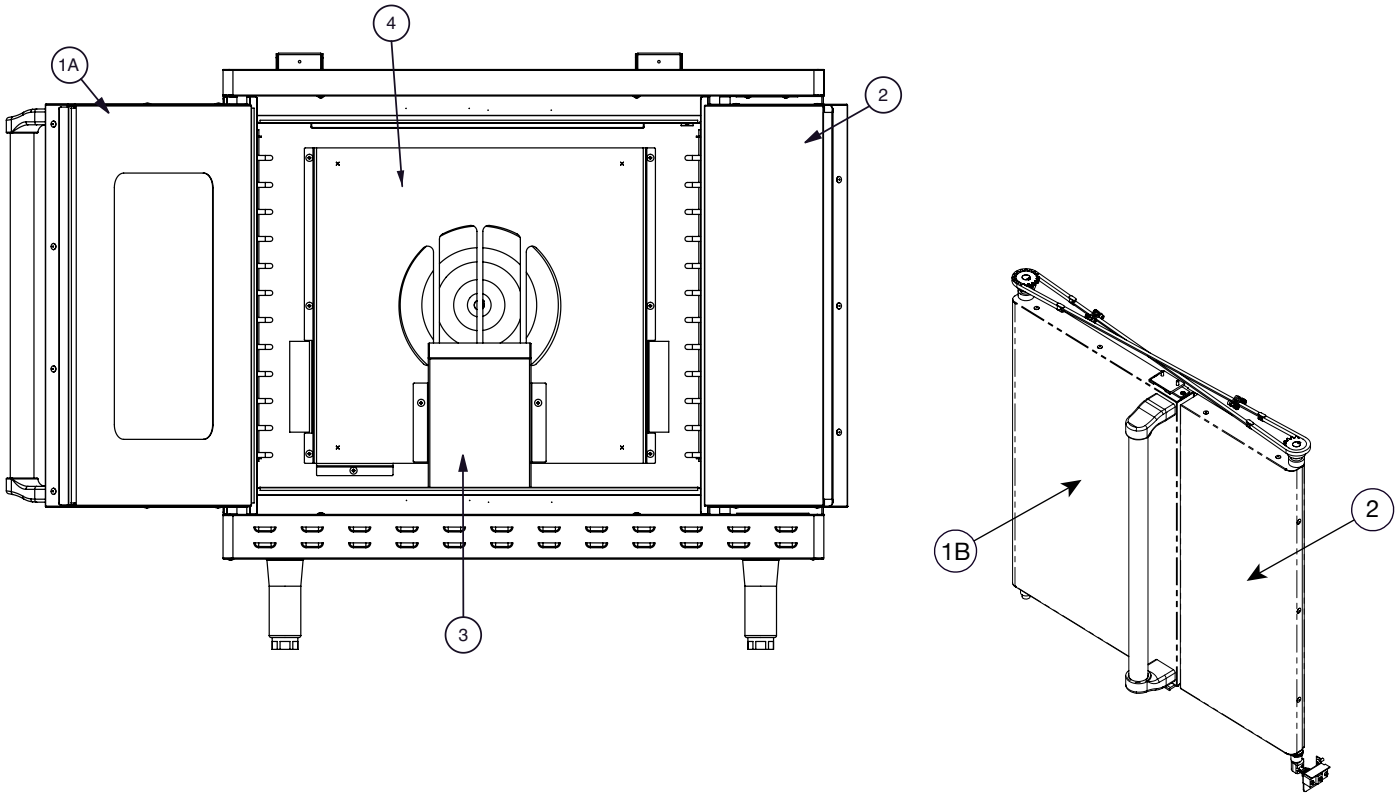

ITEM	DESCRIPTION	PART NO.	QTY
1A	DOOR ASSEMBLY, LEFT HAND WINDOW	DR-27850	1
1B	DOOR ASSEMBLY, LEFT HAND SOLID	DR-36068	1
2	DOOR ASSEMBLY, RIGHT HAND	DR-27849	1
3	HEAT BOX	5013197	1
4	BAFFLE, REAR	1004114	1

WARNING



To prevent **SERIOUS INJURY, DEATH,** or **PROPERTY DAMAGE:**

Installation, air adjustment and/or service work must be in accordance with all local codes and must be performed by a trained service technician qualified to work on gas appliances.



WARNING

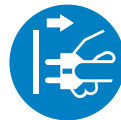

To prevent serious injury, death, or property damage, **always** disconnect the appliance from the power source before cleaning or servicing.

Part numbers and drawings are subject to change without notice.

MOTOR

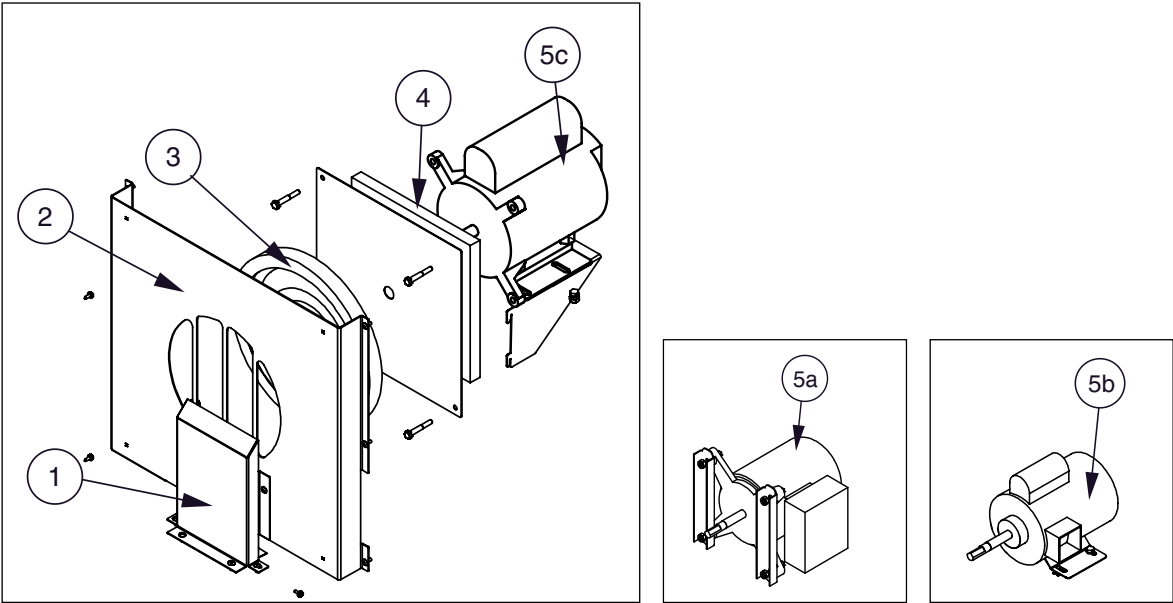

ITEM	DESCRIPTION	PART NO.	QTY
1	HEAT BOX	5013197	1
2	BAFFLE, REAR	1004114	1
3	BLOWER WHEEL	WH-26397	1
4	INSULATION	IN-27866	1
5a	CONVECTION MOTOR 115V FOR MO-34214	5010354*	1
5b	CONVECTION MOTOR CONVERSION KIT 115V FOR MO-34791	5017055**	1
5c	CONVECTION MOTOR 115V	MO-36344***	1

* Back panel X bolt mounted
** Platform mounted prior to serial number 1206029
*** Platform mounted

Part numbers and drawings are subject to change without notice.

SERVICE

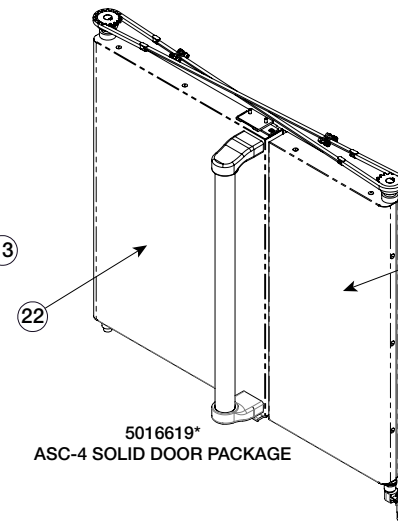
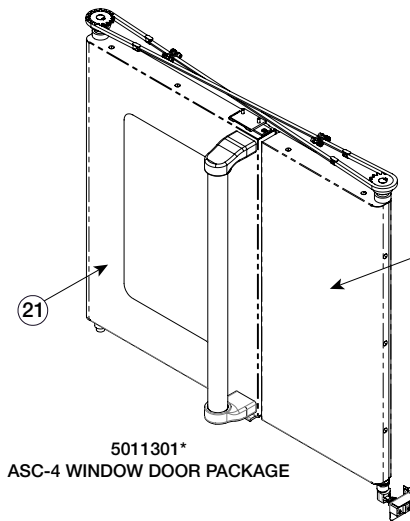
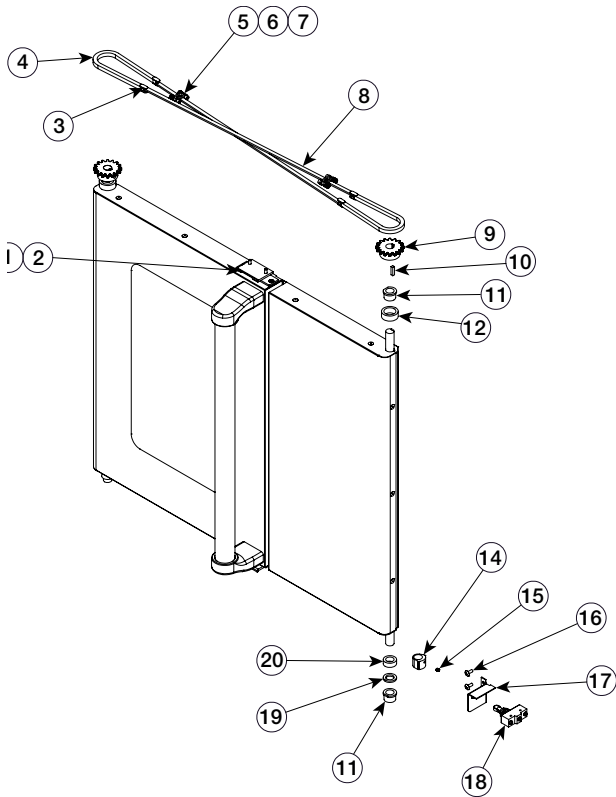

*REFERENCE NUMBERS ONLY

Item	Description	Part No.	5011301/Qty	5016619/Qty
1	Screw, 10-32 x 1/2, NF Phil, flat	SC-23670	8	8
2	Roller latch with strike	LT-26976	2	2
3	Chain, master link	CH-26622	4	4
4	Chain, door drive	CH-26623	2	2
5	Linkage assy, short	5003667	2	2
6	Screw, #10-32 x 0.75 SHC	SC-26704	4	4
7	Nut, 10-32 unf hex MS, 18-8 sst	NU-2215	8	8
8	Linkage assy, long	5003666	2	2
9	Sprocket, 0.625" Bore, 35 bs 16t	SO-26620	2	2
10	Block, key sprocket	BK-26625	2	2
11	Bushing, 0.63 x 0.63	BU-26433	4	4
12	Spacer	SP-27997	2	2
13	Door assy, RH	DR-27849	1	1
14	Hinge, door cam switch	HG-27334	1	1
15	Screw, set #10-32 x 0.25 lg	SC-27433	1	1
16	Screw, 10-32 x 1/2, NF Phil truss M/S, 18-8 S/S	SC-2661	2	2
17	Bracket, door switch	1006712	1	1
18	Switch, door roller	SW-34164	1	1
19	Spacer, door	1005449	2	2
20	Spacer, door	SP-26442	2	2
21	Door, window LH assembly	DR-27850	1	-
22	Door, solid LH assembly	DR-36068	-	1

Part numbers and drawings are subject to change without notice.

DOOR MECHANISM

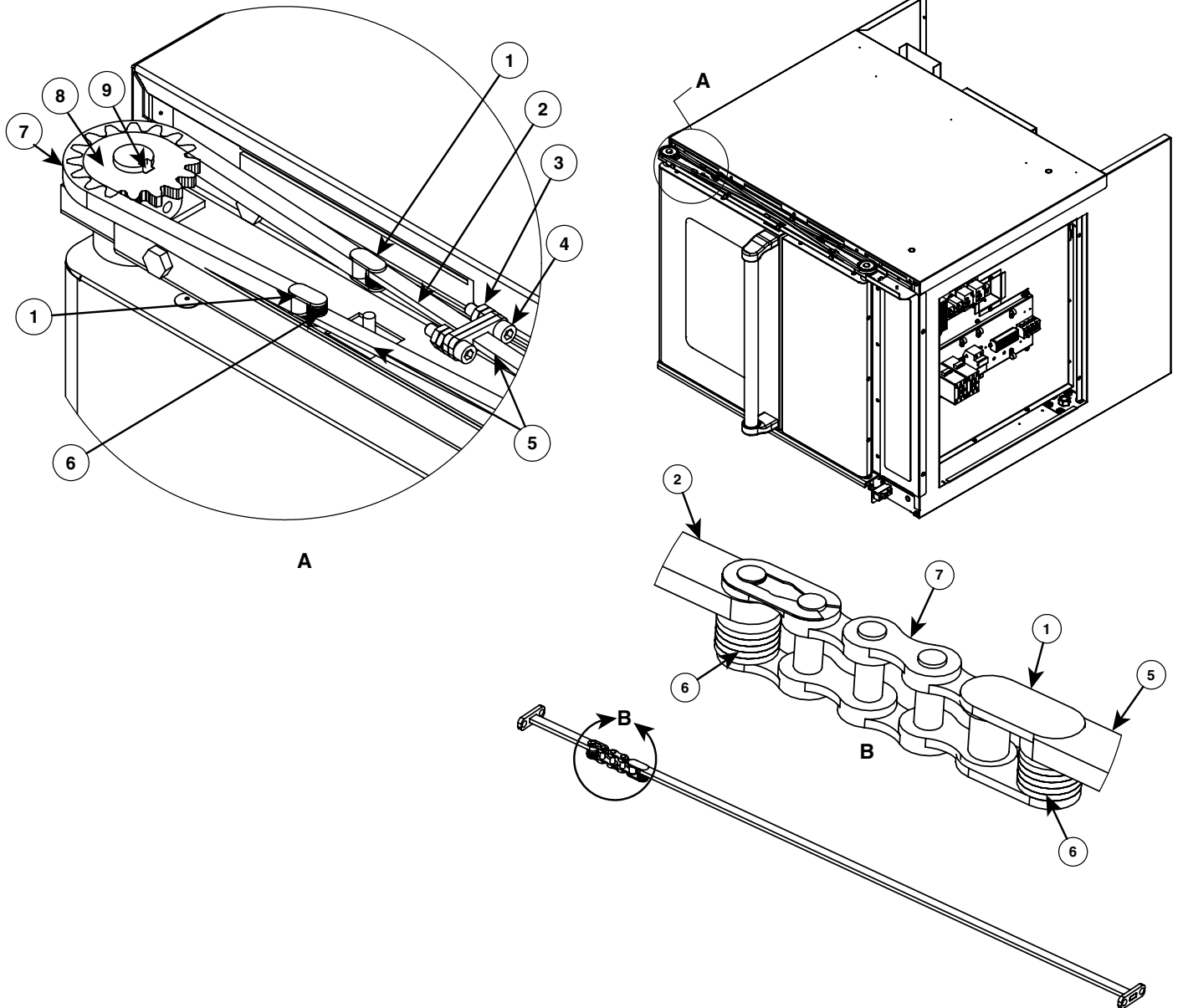

ITEM	DESCRIPTION	PART NO.	QTY
1	CHAIN, MASTER LINK	CH-26622	4
2	LINKAGE ASSEMBLY, SHORT	5003667	2
3	NUT, 10-32 UNF HEX MS, 18-8 SST	NU-2215	8
4	SCREW, 10-32 x 0.75 SCH	SC-26704	4
5	LINKAGE ASSEMBLY, LONG	5003666	2
6	WASHER, 6-32, FLAT, NYLON	WS-23148	20
7	CHAIN, DOOR DRIVE	CH-26623	2
8	SPROCKET, DOOR	SO-26620	2
9	BLOCK, KEY SPROCKET	BK-26625	2

Part numbers and drawings are subject to change without notice.

SERVICE

DOOR HARDWARE

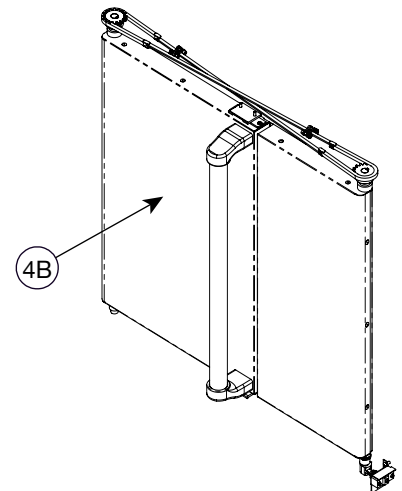
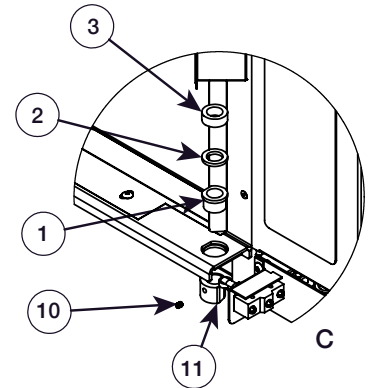
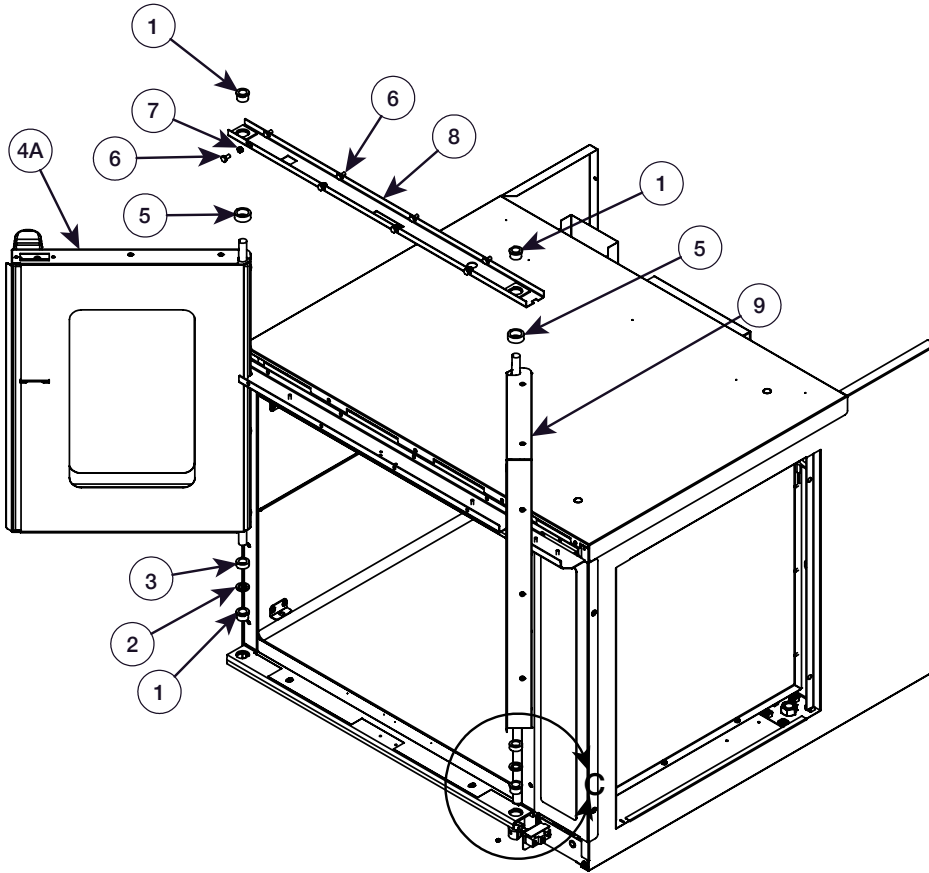

ITEM	DESCRIPTION	PART NO.	QTY
1	BUSHING	BU-26433	4
2	SPACER, DOOR	1005449	2
3	SPACER, DOOR	SP-26442	2
4A	DOOR ASSEMBLY, LH WINDOW	DR-27850	1
4B	DOOR ASSEMBLY, LH SOLID	DR-36068	1
5	SPACER	SP-27997	2
6	SCREW, 1/4-20 x 1/2" HEX HEAD	SC-22729	8
7	NUT, 1-4-20 NYLON INSERT 18-8 S/S	NU-23984	4
8	TOP PLATE ASSEMBLY	5005404	1
9	DOOR ASSEMBLY, RH	DR-27849	1
10	SCREW, EST 10-32 x 0.25LG	SC-27433	1
11	HINGE, DOOR CAM SWITCH	HG-27334	1

Part numbers and drawings are subject to change without notice.

LEG ASSEMBLY (5003784)

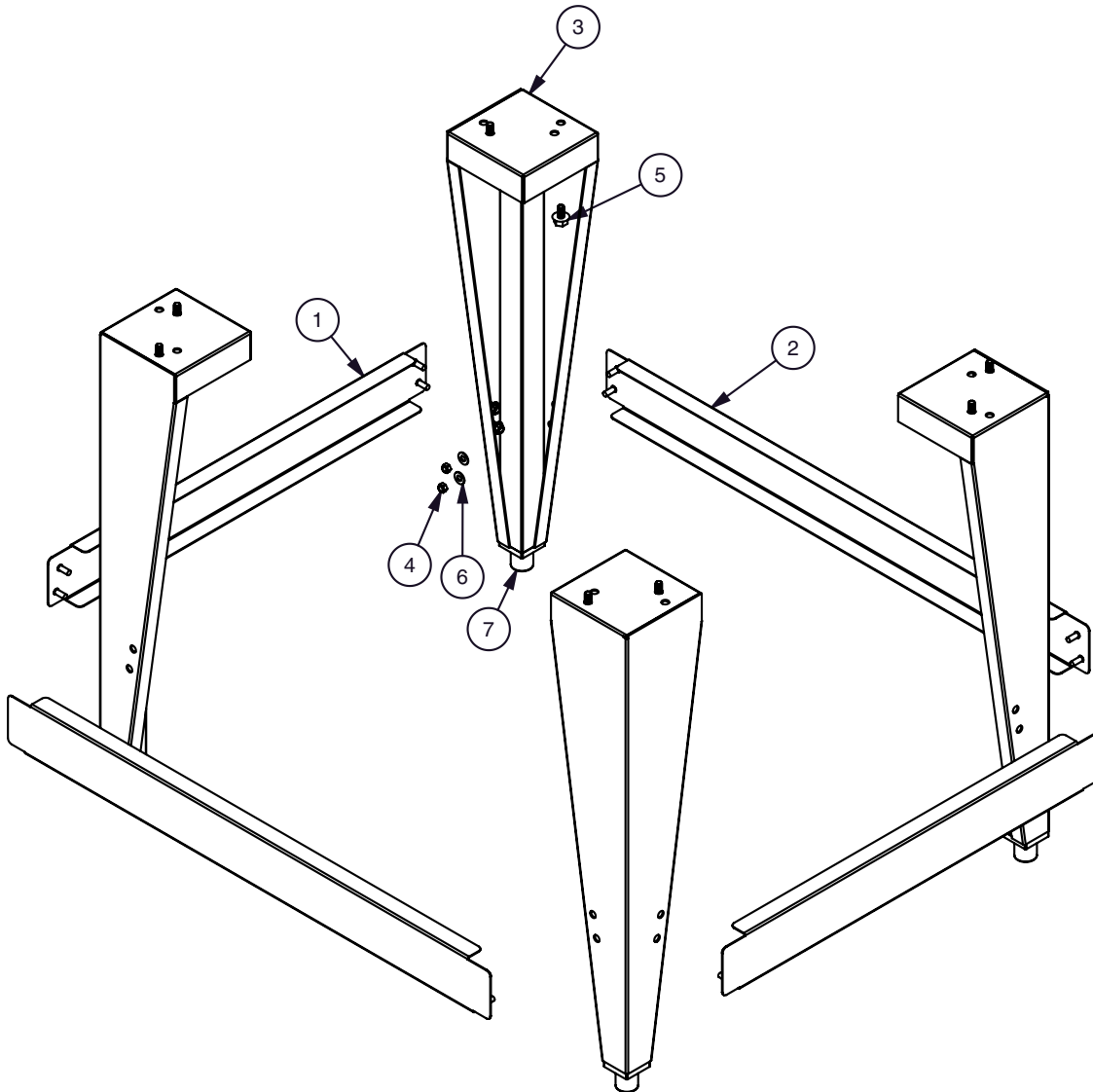

ITEM	DESCRIPTION	PART NO.	QTY
1	SUPPORT, LEG, SIDE, ASSEMBLY	5009564	2
2	SUPPORT, LEG, REAR, ASSEMBLY	5009565	2
3	LEG ASSEMBLY, 25"	LG-27829	4
4	NUT, 1/4-20 NYLON INSERT 18-8 S/S	NU-23984	16
5	SCREW, 5/16-18 x 5/8 SERR. HEX HD	SC-2351	8
6	WASHER, 1/4", FLAT, 5/8 OD 18-8 S/S	WS-22094	16
7	LEGS, CT, ADJUST, LEVELING	LG-22185	4

Part numbers and drawings are subject to change without notice.

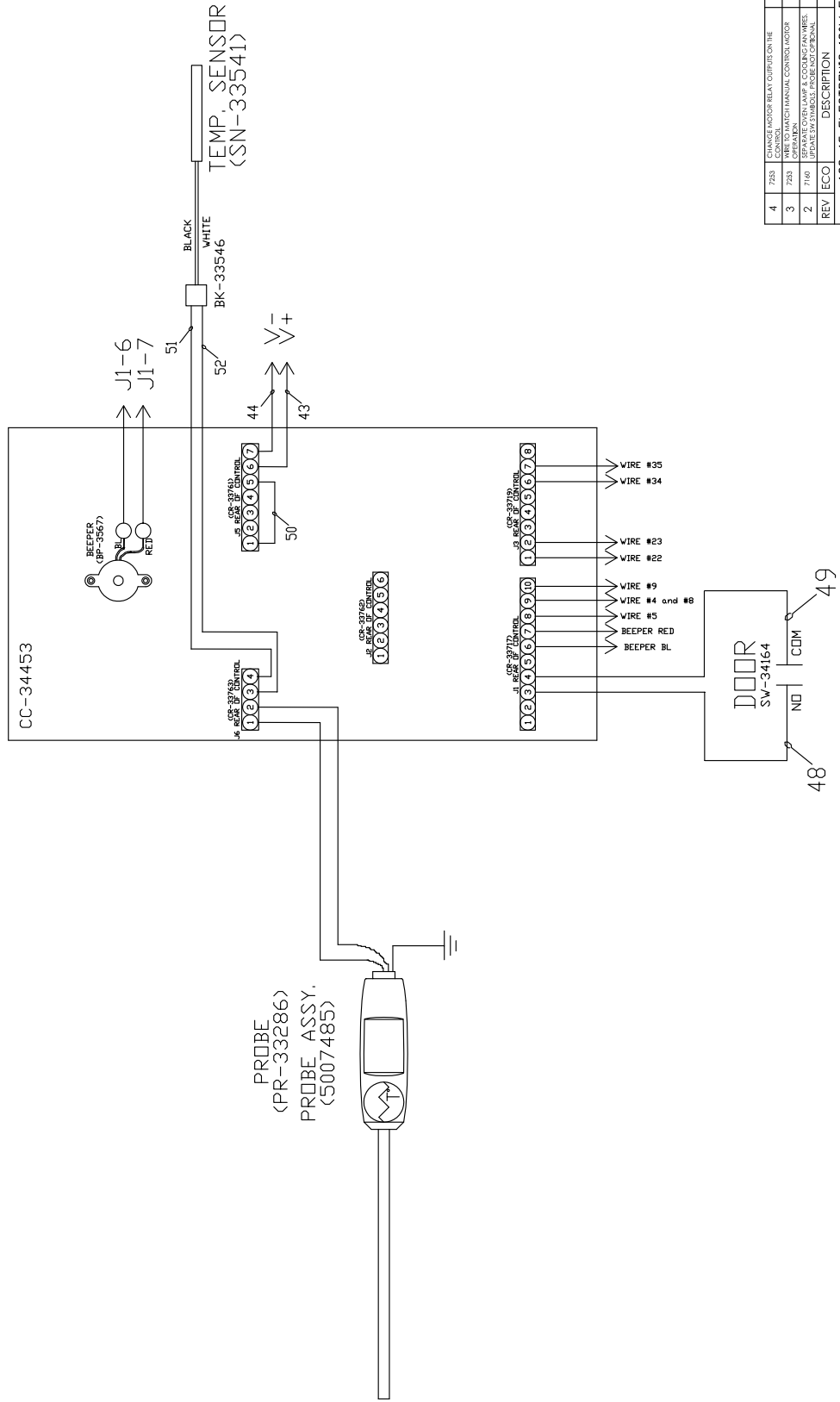

4	7233	CHANGE MOTOR RELAY COMPARE ON THE CONTROL	12/17/14	NVD
3	7233	WIRE TO MATCH MANUAL CONTROL MOTOR	10/28/14	NVD
2	7169	SEPARATE OVEN LAMP & COOLING FAN WIRES. UPDATE W/33 LABELS AND RESET OPTIONAL	8/26/14	NVD
REV	ECO	DESCRIPTION	DATE	APP
ASC-4G ELECTRONIC 120V 50/60HZ				
ALTO-SHAAM			WIRING DIAGRAM	
BY: NVA/DAE 09/06/13			DWG: 77565	
			SHEET	
			2_OF_2	

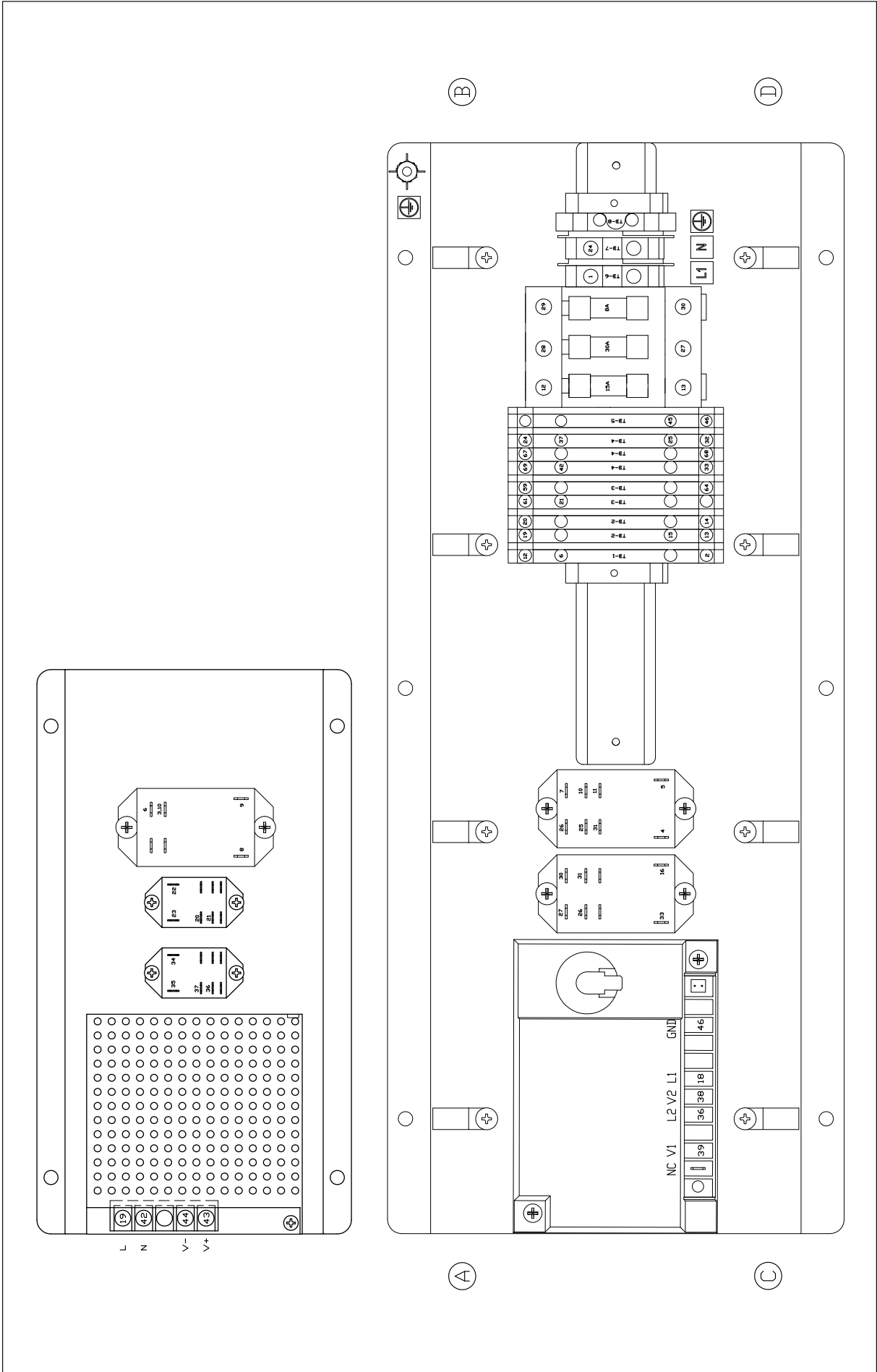

TRANSPORTATION DAMAGE and CLAIMS



All Alto-Shaam equipment is sold F.O.B. shipping point, and when accepted by the carrier, such shipments become the property of the consignee.

Should damage occur in shipment, do not put the appliance into service until the damage has been inspected by an authorized Alto-Shaam service provider.

Shipping damages are a matter between the carrier and the consignee. In such cases, the carrier is assumed to be responsible for the safe delivery of the merchandise, unless negligence can be established on the part of the shipper.

1. Make an immediate inspection while the equipment is still in the truck or immediately after it is moved to the receiving area. Do not wait until after the material is moved to a storage area.
2. Do not sign a delivery receipt or a freight bill until you have made a proper count and inspection of all merchandise received.
3. Note all damage to packages directly on the carrier's delivery receipt.
4. Make certain the driver signs this receipt. If he refuses to sign, make a notation of this refusal on the receipt.
5. If the driver refuses to allow inspection, write the following on the delivery receipt:
Driver refuses to allow inspection of containers for visible damage.
6. Telephone the carrier's office immediately upon finding damage, and request an inspection. Mail a written confirmation of the time, date, and the person called.
7. Save any packages and packing material for further inspection by the carrier.
8. Promptly file a written claim with the carrier and attach copies of all supporting paperwork.

We will continue our policy of assisting our customers in collecting claims which have been properly filed and actively pursued. We cannot, however, file any damage claims for you, assume the responsibility of any claims, or accept deductions in payment for such claims.

LIMITED WARRANTY

Alto-Shaam, Inc. warrants to the original purchaser only that any original part that is found to be defective in material or workmanship will, at Alto-Shaam's option, subject to provisions hereinafter stated, be replaced with a new or rebuilt part.

The original parts warranty period is as follows:

For the refrigeration compressor on Alto-Shaam Quickchillers™, five (5) years from the date of installation of appliance.

For the heating element on Halo Heat® cooking and holding ovens, as long as the original purchaser owns the oven. This excludes holding only equipment.

For all other original parts, one (1) year from the date of installation of appliance or fifteen (15) months from the shipping date, whichever occurs first.

The labor warranty period is one (1) year from the date of installation or fifteen (15) months from the shipping date, whichever occurs first.

Alto-Shaam will bear normal labor charges performed during standard business hours, excluding overtime, holiday rates or any additional fees.

To be valid, a warranty claim must be asserted during the applicable warranty period. This warranty is not transferable.

THIS WARRANTY DOES NOT APPLY TO:

1. Calibration.
2. Replacement of light bulbs, door gaskets, and/or the replacement of glass due to damage of any kind.
3. Equipment damage caused by accident, shipping, improper installation or alteration.
4. Equipment used under conditions of abuse, misuse, carelessness or abnormal conditions, including but not limited to, equipment subjected to harsh or inappropriate chemicals, including but not limited to, compounds containing chloride or quaternary salts, poor water quality, or equipment with missing or altered serial numbers.
5. Damage incurred as a direct result of poor water quality, inadequate maintenance of steam generators and/or surfaces affected by water quality. Water quality and required maintenance of steam generating equipment is the responsibility of the owner/operator.
6. Damage caused by use of any cleaning agent other than Alto-Shaam's Combitherm® Cleaner, including but not limited to damage due to chlorine or other harmful chemicals. **Use of Alto-Shaam's Combitherm® Cleaner on Combitherm® ovens is highly recommended.**
7. Any losses or damage resulting from malfunction, including loss of product, food product, revenue, or consequential or incidental damages of any kind.
8. Equipment modified in any manner from original model, substitution of parts other than factory authorized parts, removal of any parts including legs, or addition of any parts.

This warranty is exclusive and is in lieu of all other warranties, express or implied, including the implied warranties of merchantability and fitness for a particular purpose. In no event shall Alto-Shaam be liable for loss of use, loss of revenue or profit, or loss of product, or for any indirect, special, incidental, or consequential damages. No person except an officer of Alto-Shaam, Inc. is authorized to modify this warranty or to incur on behalf of Alto-Shaam any other obligation or liability in connection with Alto-Shaam equipment.

The logo for Alto-Shaam, featuring the company name in a bold, sans-serif font. The letter 'O' in 'SHAAM' is stylized with a circular graphic element around it.

Effective November 1, 2012

W164 N9221 Water Street • P.O. Box 450
Menomonee Falls, Wisconsin 53052-0450 U.S.A.

PHONE: 262.251.3800 • 800.558.8744 U.S.A. / CANADA
FAX: 262.251.7067 • 800.329.8744 U.S.A. ONLY

www.alto-shaam.com

PRINTED IN U.S.A.