

Vector[®] Multi-Cook Oven

**Commercial Gas Oven with
Simple or Deluxe Control**

VMC-F3G
VMC-F4G



Manufacturer's Information

Copyright © Copyright 11/2021 by Alto-Shaam, Inc.
 All rights reserved.
 This manual or any portion thereof may not be reproduced or used in any manner whatsoever without the express written permission of Alto-Shaam, Inc

Trademarks All trademarks referenced in this documentation are the property of their respective owners.

Manufacturer Alto-Shaam, Inc.
 P.O. Box 450
 W164 N9221 Water Street
 Menomonee Falls, WI 53052

Models Covered

Full-Size Sheet Pan Models VMC-F3G (Simple and Deluxe Control) VMC-F4G (Simple and Deluxe Control)	US (UL Certified) Models International (CE Certified) Models
---	--

Serial Number The unit serial number is required for ordering the correct service parts. Record the unit serial number in the space provided below.

Serial Number

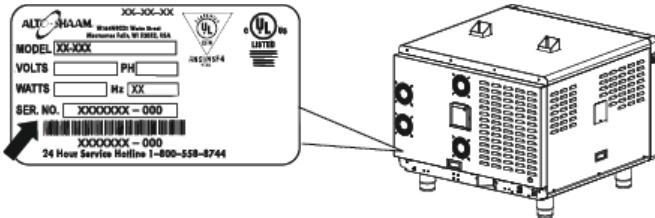

Parts Ordering Information Original manufacturer's replacement parts may be ordered directly from the Alto-Shaam network of Authorized Service Agents and Parts Distributors. Follow this link for a map to a local partner: <https://www.alto-shaam.com/en/how-to-buy>. If you are an Authorized Service Agent or Parts Distributor, please submit your purchase order to parts@alto-shaam.com.

Non-OEM parts may be substituted; however, these parts must be of equal quality and specifications as those provided by Alto-Shaam.

Table of Contents

- Manufacturer’s Information 2
- Table of Contents 3
- Core Assembly Front View—F3G 4
- Core Assembly Rear View—F3G 5
- Core Assembly Gas Components—F3G 6
- Core Assembly Front View—F4G 7
- Core Assembly Rear View—F4G 8
- Core Assembly Gas Components—F4G 9
- Motor/Fan Assembly (all models)..... 10
- Left Door Assembly, Simple—F3G 11
- Left Door Assembly, Deluxe—F3G 12
- Right Door Assembly (Simple and Deluxe)—F3G 13
- Left Door Assembly, Simple—F4G 14
- Left Door Assembly, Deluxe—F4G 15
- Right Door Assembly (Simple and Deluxe)—F4G 16
- Control Assembly, Simple—F3G 17
- Control Assembly, Deluxe—F3G 18
- Control Assembly, Simple—F4G 19
- Control Assembly, Deluxe—F4G 20
- Electrical Package, 120V—F3G..... 21
- Electrical Chassis, 120V—F3G 22
- Electrical Package, 220V—F3G..... 23
- Electrical Chassis, 220V—F3G 24
- Electrical Package, 208-240V—F3G 25
- Electrical Chassis, 208-240V—F3G 26
- Chassis, Ignition Module—F3G 27
- Electrical Package, 120V—F4G..... 28
- Electrical Chassis, 120V—F4G 29
- Electrical Package, 220V—F4G..... 30
- Electrical Chassis, 220V—F4G 31
- Electrical Package, 220-240V—F4G 32
- Electrical Chassis, 208-240V—F4G 33
- Chassis, Ignition Module—F4G 34
- Control Board Service Kit (All Models) 35
- Intake Flap Assemblies and Air Return (All Models) 36
- Probes (All Models) 37
- Mobile Base and Casters (All Models)..... 38

Core Assembly Front View—F3G

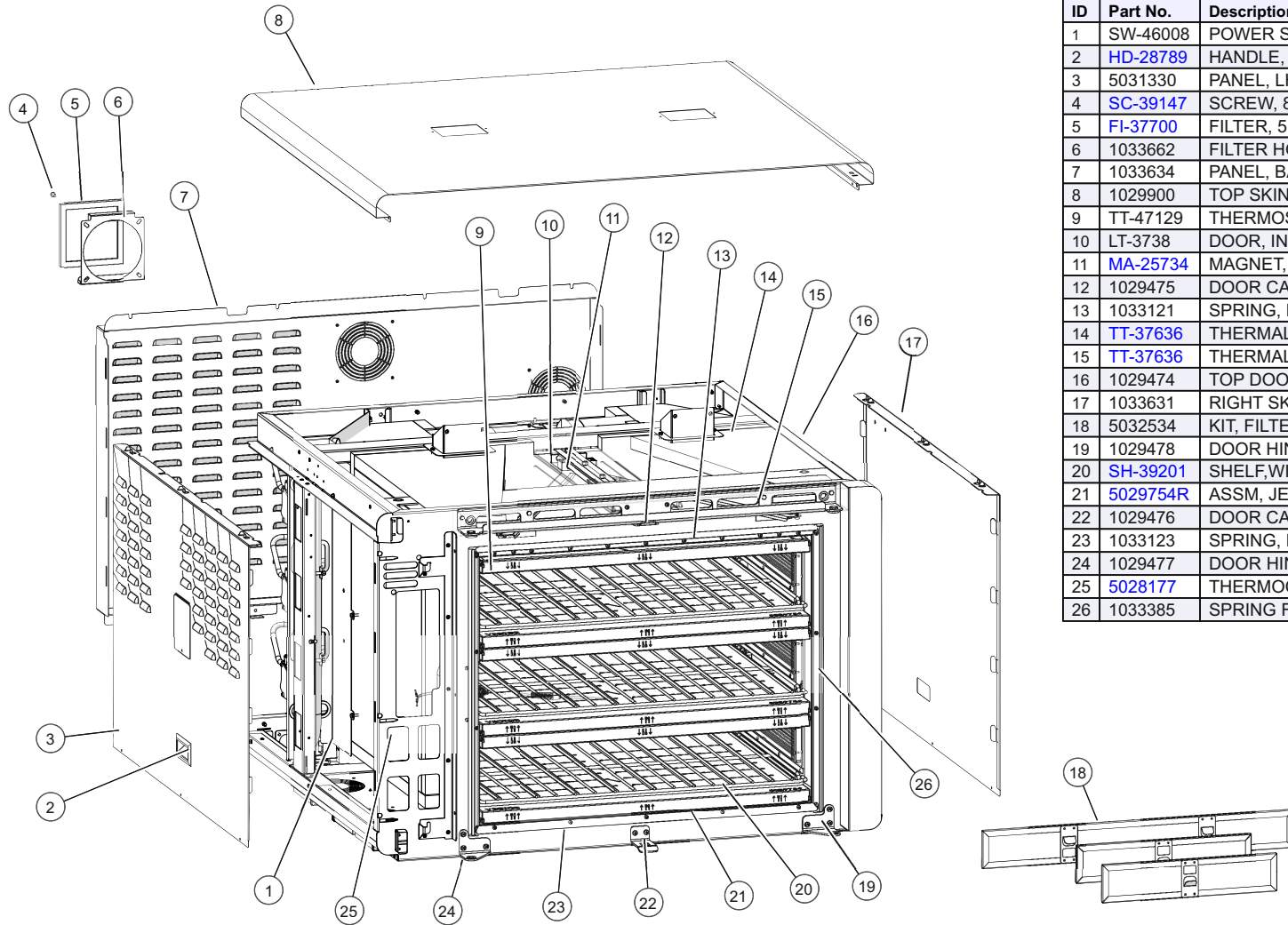

ID	Part No.	Description
1	SW-46008	POWER SWITCH,DISCONNECT 40A
2	HD-28789	HANDLE, PULL RECESSED, BLACK
3	5031330	PANEL, LH ASSEMBLY VF3
4	SC-39147	SCREW, 8-18 X .480 HEX WASHER
5	FI-37700	FILTER, 5IN X 5IN
6	1033662	FILTER HOLDER, SINGLE
7	1033634	PANEL, BACK CAV, F3 GAS
8	1029900	TOP SKIN, VOLPI F
9	TT-47129	THERMOSTAT,AUTO RESET,
10	LT-3738	DOOR, INTERLOCK SWITCH
11	MA-25734	MAGNET, DOOR, AR-7E,BLACK
12	1029475	DOOR CATCH, TOP, VOLPI F
13	1033121	SPRING, FLANGE, TOP, HORZ FULL
14	TT-37636	THERMAL CUTOFF, MECHANICAL,
15	TT-37636	THERMAL CUTOFF, BULB END
16	1029474	TOP DOOR HINGE, VOLPI F
17	1033631	RIGHT SKIN, VF3 GAS
18	5032534	KIT, FILTER ASSEMBLY (1 kit/chamber)
19	1029478	DOOR HINGE, BOT RT, VOLPI F
20	SH-39201	SHELF,WIRE,COOK,RACK
21	5029754R	ASSM, JET PLATE, FULL
22	1029476	DOOR CATCH, BOTTOM, VOLPI F
23	1033123	SPRING, FLANGE, BTM, HORZ FULL
24	1029477	DOOR HINGE, BOT LF, VOLPI F
25	5028177	THERMOCOUPLE/GASKET KIT
26	1033385	SPRING FLANGE, DOOR, SIDE, F3

Core Assembly Rear View—F3G

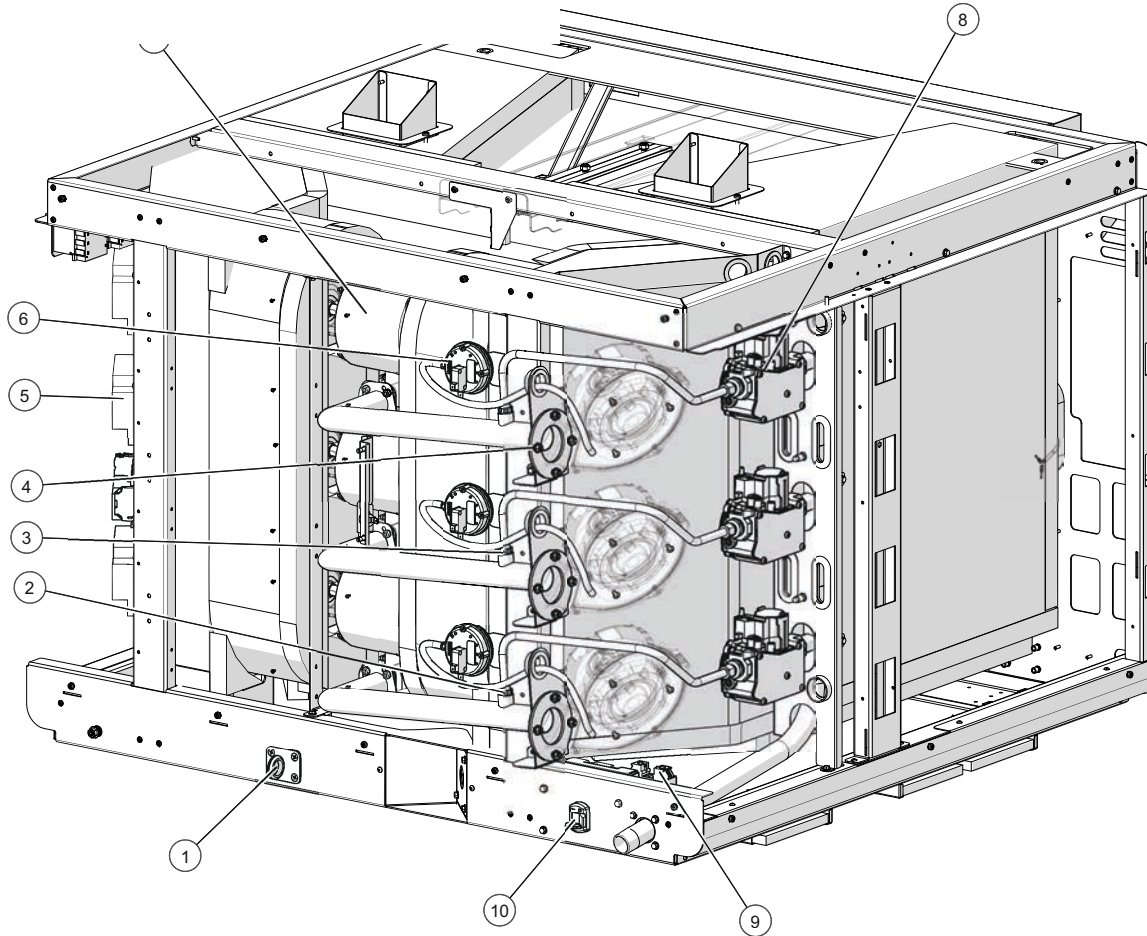

ID	Part No.	Description
1	BT-26884	BRACKET, TETHER.
2	OR-39862	ORIFICE, NATURAL
3	OR-39986	ORIFICE, PROPANE
4	SA-27006	SEAL-FAN BURNER
5	5032285	CHASSIS, IGNITION MOD, 3 CAV
6	SW-46990	SWITCH, PRESSURE
7	5024168R	MOTOR FAN ASSEMBLY
8	5032490	KIT, REPLACEMENT GAS VALVE, LP
9	TM-47500	TERMINAL, GROUND, 16MM, 800V
10	SW-46008	POWER SWITCH,DISCONNECT 40A

Core Assembly Gas Components—F3G

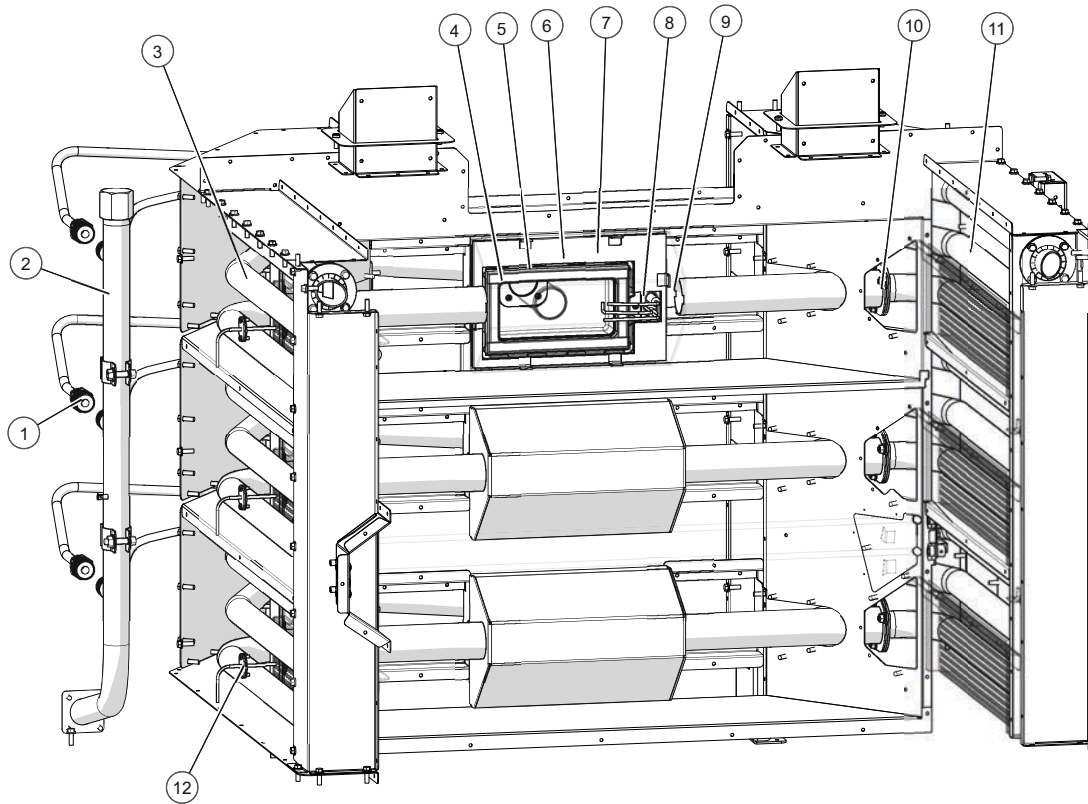

ID	Part No.	Description
1	FT-39888	FITTING, COMPRESSION
2	PP-46033	MANIFOLD, GAS F3 SERIES
3	5032481	HEAT EXCHANGER SVC KIT, LH 28mm
4	GS-46022	GASKET,MIX TUBE/BURNER
5	5030914	WELDMENT, BURNER
6	1033910	GASKET, BURNER BOX, FULL FACE
7	5029045	COMBUSTION BOX ASM
8	5032483	IGNITER KIT
9	GS-46024	GASKET,IGNITER/BURNER BOX
10	GS-46020	GASKET BURNERBOX TO HEAT EXCH
11	5032482	HEAT EXCHANGER SVC KIT, RT 28mm
12	5027177	THERMOCOUPLE/GASKET KIT
13	5031882	CONVERSION KIT, GAS TO LP (not shown)
14	5031923	CONVERSION KIT, LP TO GAS (not shown)
15	5032484	BURNER SERVICE KIT (not shown)
16	5033089	INSULATION KIT, COMBUSTION BOX (not shown)
17	5033368	INSULATION KIT, MOTOR/BURNER (not shown)

Core Assembly Front View—F4G

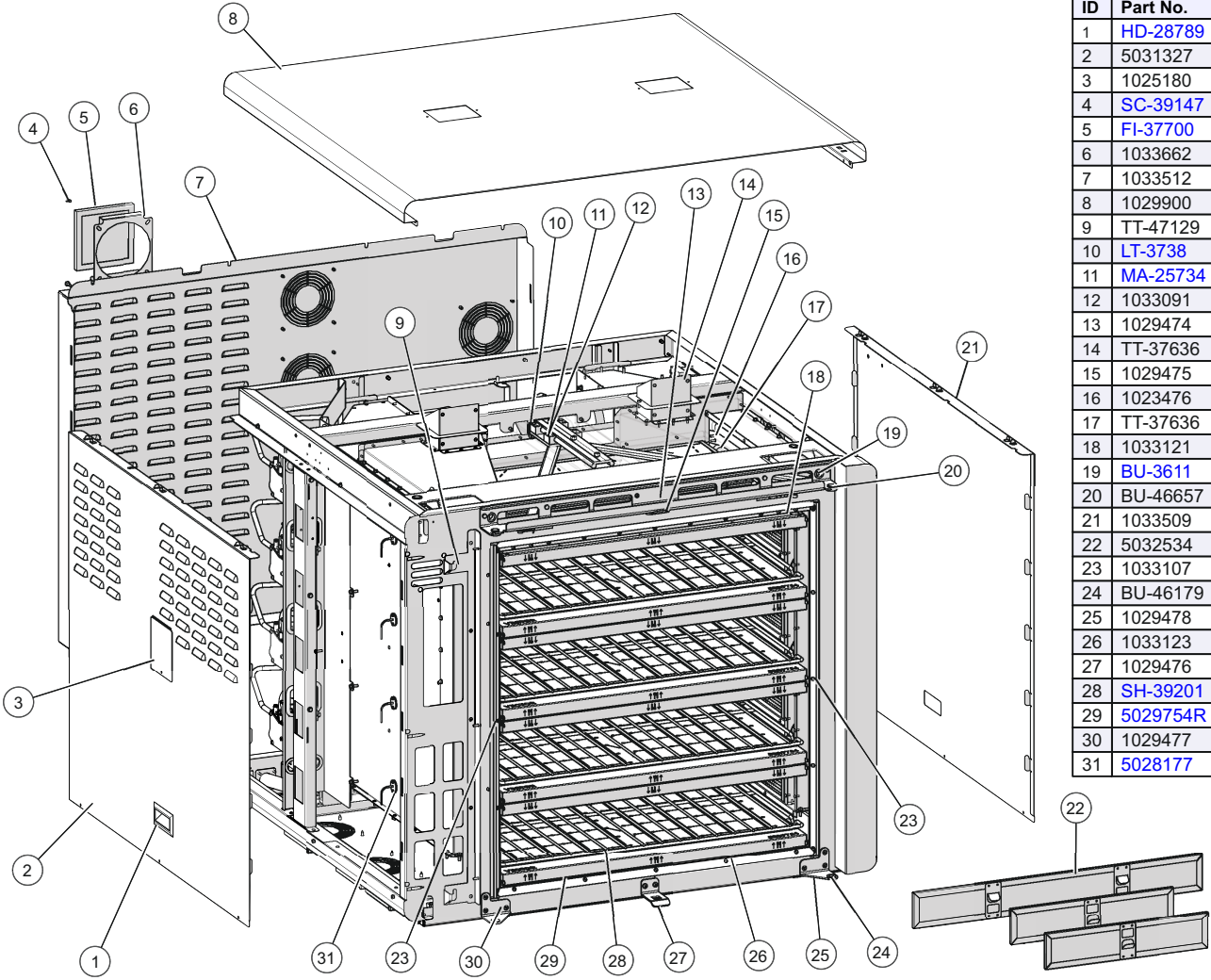

ID	Part No.	Description
1	HD-28789	HANDLE, PULL RECESSED, BLACK
2	5031327	PANEL, LH ASSEMBLY VF4
3	1025180	DOOR, FUSE COVER
4	SC-39147	SCREW, 8-18 X .480 HEX WASHER
5	FI-37700	FILTER, 5IN X 5IN
6	1033662	FILTER HOLDER, SINGLE, HALF
7	1033512	PANEL, BACK CAV, F4 GAS
8	1029900	TOP SKIN, VOLPI F
9	TT-47129	THERMOSTAT,AUTO RESET,
10	LT-3738	DOOR, INTERLOCK SWITCH
11	MA-25734	MAGNET, DOOR, AR-7E,BLACK
12	1033091	COVER, MAGNET, INSIDE, SINGLE
13	1029474	TOP DOOR HINGE, VOLPI F
14	TT-37636	THERMAL CUTOFF, MECHANICAL,
15	1029475	DOOR CATCH, TOP, VOLPI F
16	1023476	BULB HOLDER, HIGH LIMIT
17	TT-37636	THERMAL CUTOFF, BULB END
18	1033121	SPRING, FLANGE, TOP, HORZ FULL
19	BU-3611	5/8" SNAP BUSHING BLACK
20	BU-46657	BUSHING,FLNG ID.625,OD 3/4X5/8
21	1033509	RIGHT SKIN, VOLPI F4 GAS
22	5032534	KIT, FILTER ASSEMBLY (1 set/chamber)
23	1033107	SPRING FLANGE, DOOR, SIDE, F4
24	BU-46179	BUSHING,FLNG ID.625,OD 3/4X5/8
25	1029478	DOOR HINGE, BOT RT, VOLPI F
26	1033123	SPRING, FLANGE, BTM, HORZ FULL
27	1029476	DOOR CATCH, BOTTOM, VOLPI F
28	SH-39201	SHELF,WIRE,COOK,RACK
29	5029754R	ASSM, JET PLATE, FULL
30	1029477	DOOR HINGE, BOT LF, VOLPI F
31	5028177	THERMOCOUPLE/GASKET KIT

Core Assembly Rear View—F4G

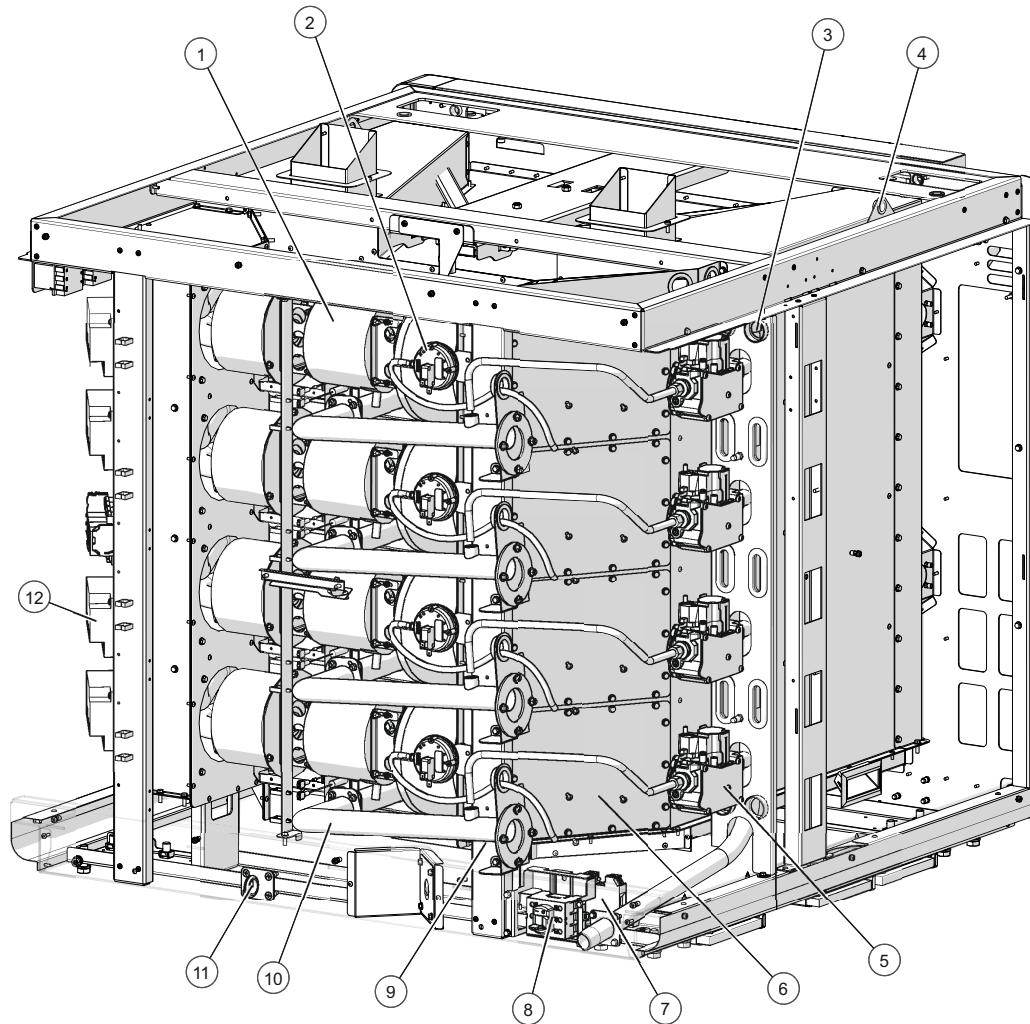

ID	Part No.	Description
1	5024168R	MOTOR FAN ASSEMBLY
2	SW-46990	SWITCH, PRESSURE
3	BU-37626	1-1/4" SNAP BUSHING
4	BU-3611	5/8" SNAP BUSHING BLACK
5	5032490	KIT, REPLACEMENT GAS VALVE, LP
6	1028026	COVER, HEAT EXCHANGER
7	TM-47500	TERMINAL, GROUND, 16MM, 800V
8	SW-46008	POWER SWITCH, DISCONNECT 40A
9	SA-27006	SEAL-FAN BURNER
10	5026790	TUBE, COMBUSTION AIR MIXING
11	BT-26884	BRACKET, TETHER.
12	5032284	CHASSIS, IGNITION MOD, 4 CAV
13	CB-47255	CABLE, MOTOR DRIVE (not shown)
14	HO-37315	PRESSURE SWITCH TUBE, 18-3/8" LG (not shown)

Core Assembly Gas Components—F4G

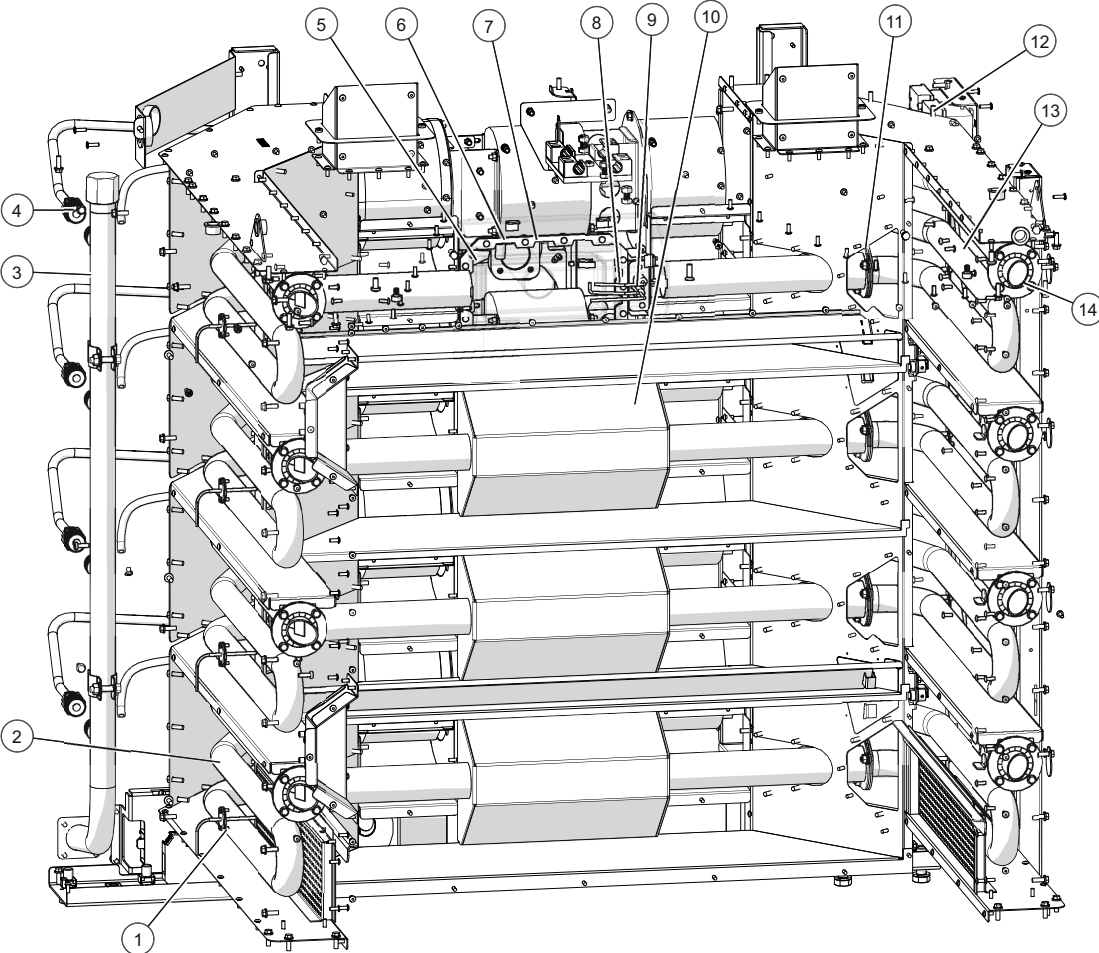

ID	Part No.	Description
1	5028177	THERMOCOUPLE/GASKET KIT
2	5032481	SVC KIT, HEAT EXCHANGER, LH 28mm
3	PP-46025	MANIFOLD, GAS F4 SERIES
4	FT-39888	FITTING, COMPRESSION
5	5030914	WELDMENT, BURNER
6	GS-46022	GASKET,MIX TUBE/BURNER
7	1033910	GASKET, BURNER BOX, FULL FACE
8	5032483	IGNITER KIT
9	GS-46024	GASKET,IGNITOR/BURNER BOX
10	5029044	KIT, COMBUSTION BOX ASM
11	GS-46020	GASKET BURNERBOX TO HEAT EXCH
12	TT-37636	THERMAL CUTOFF, MECHANICAL,
13	5032482	SVC KIT,HEAT EXCHANGER, RT 28mm
14	1033520	GASKET, FLUE INSERT
15	5031881	CONVERSION KIT, NG TO LP (not shown)
16	5031924	CONVERSION KIT, LP TO NG (not shown)
17	5032484	BURNER SERVICE KIT (not shown)
18	5033088	INSULATION KIT, COMBUSTION BOX (not shown)
19	5033367	INSULATION KIT, MOTOR/BURNER (not shown)

Motor/Fan Assembly (all models)

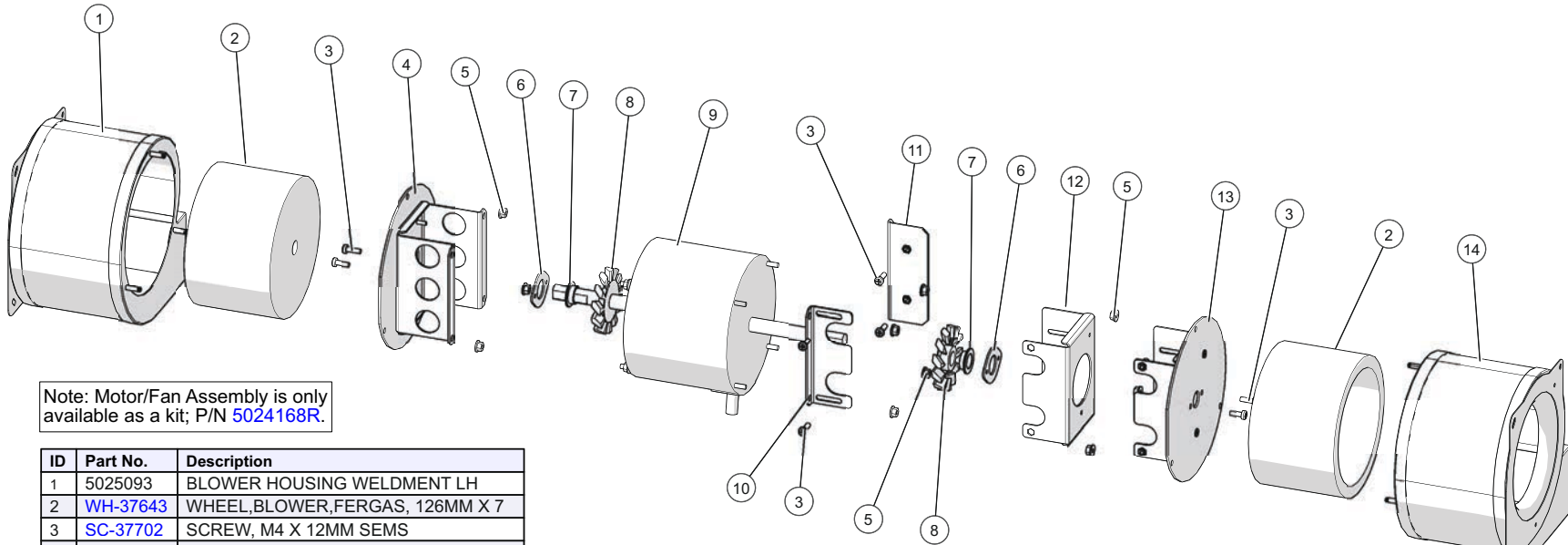

Note: Motor/Fan Assembly is only available as a kit; P/N [5024168R](#).

ID	Part No.	Description
1	5025093	BLOWER HOUSING WELDMENT LH
2	WH-37643	WHEEL,BLOWER,FERGAS, 126MM X 7
3	SC-37702	SCREW, M4 X 12MM SEMS
4	5031662	BRACKET, FAN MOTOR MTG
5	NU-39180	NUT,M4-0.7 HEX FLG-SERR CL8 SS
6	1023557	PLATE, SEAL RETAINER
7	BU-37698	BUSHING, FLANGE, 0.5 ID X .25
8	WH-37632	RADIAL BLOWER WHEEL, R-STYLE W
9	MO-39194	MOTOR,TELCO DOUBLE SHAFT
10	1025132	BRACKET, ADJ MOTOR MOUNT FRONT
11	5031700	BRKT, TOP MOTOR MOUNT ADJ
12	1034609	BRACKET, ADJ MOTOR MOUNT
13	5031663	BRACKET, MOTOR MOUNT ADJ
14	5025094	BLOWER HOUSING WELDMENT RH

Left Door Assembly, Simple—F3G

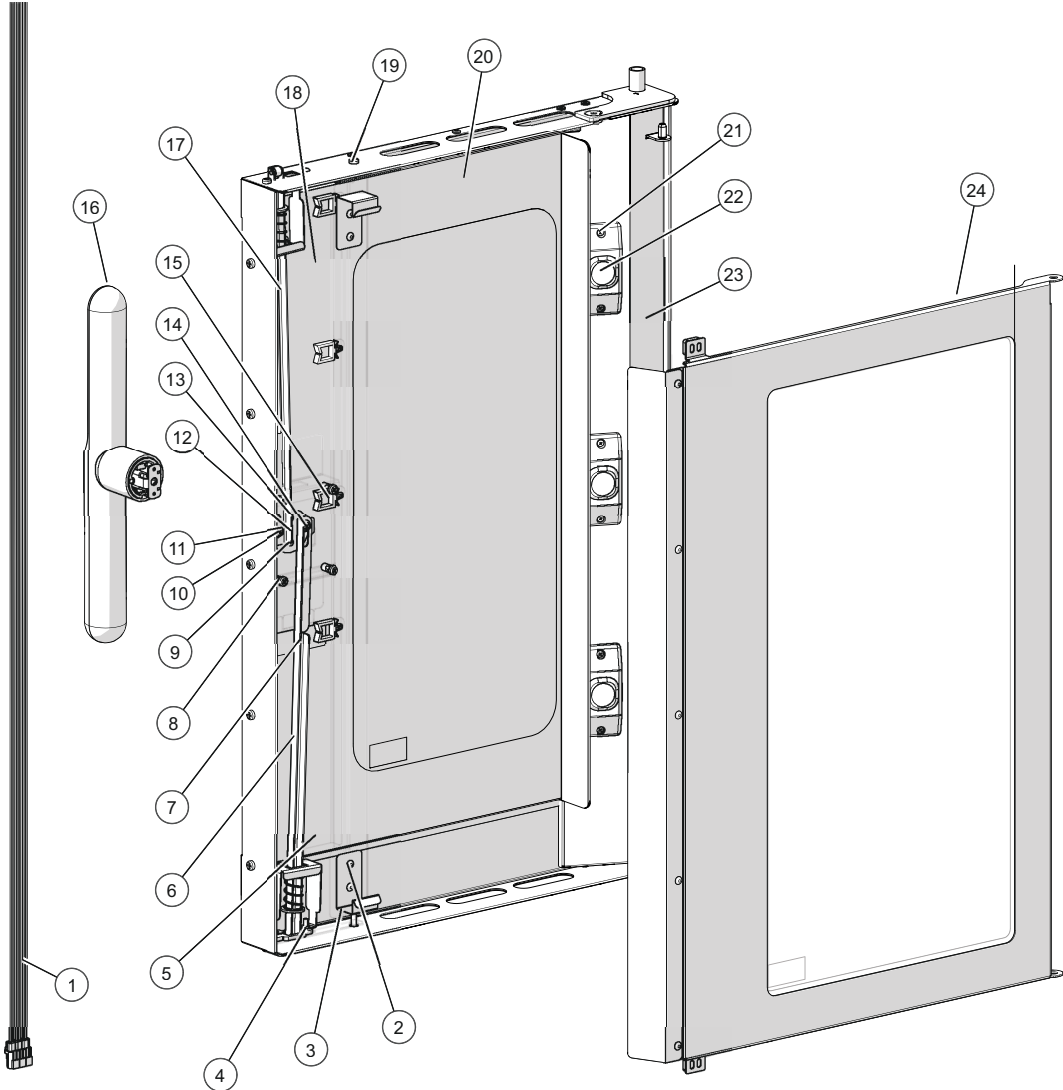

ID	Part No.	Description
1	CB-46688	CABLE HARNESS,CAVITY LIGHT,44"
2	RI-38125	RIVET,SEALED,.125", G.R. .039"-0.0118"
3	LT-47300	LATCH, INNER GLASS
4	RI-38404	RIVET,SEALED,.125", G.R. 0.197" - 0.276"
5	5032384	ASSY, LATCH PLATE, LF VF3
6	5029395	LATCH, LH VF3 LOWER DOOR ASM
7	TA-38589	LINERLESS SPLICING TAPE .75"
8	SC-37702	SCREW, M4 X 12MM SEMS
9	SC-47301	SCREW,FLAT HEAD PHILPS M3-4MM
10	WS-22293	WASHER, FLAT
11	5032808	SPACER, DOOR ASSY, WELDMENT
12	5028305	WELD ASSY, HANDLE ADAPTER
13	SC-22273	SCREW,M4x0.7X10MM PAN
14	SC-46521	SCREW, M3X0.5X4MM SCH
15	TI-35719	PUSH IN WIRE RETAINER
16	HD-46826R	HANDLE, MULTI-PT LATCH NO LED
17	5029394	LATCH, LH VF3 UPPER DOOR ASM
18	5032382	ASM, LF DOOR LATCH COVER VF3
19	RI-27108	RIVET, SEALED
20	TA-24637	TAPE, DOUBLE SIDED, 2.71FT
21	SC-22268	SCREW,M3x0.5X8MM PAN
22	5028680	LIGHT, CABINET LED
23	GS-23622	GASKET @ 1.83 Ft
24	5032378	ASSY, DOOR, INNER, LF VF3

Left Door Assembly, Deluxe—F3G

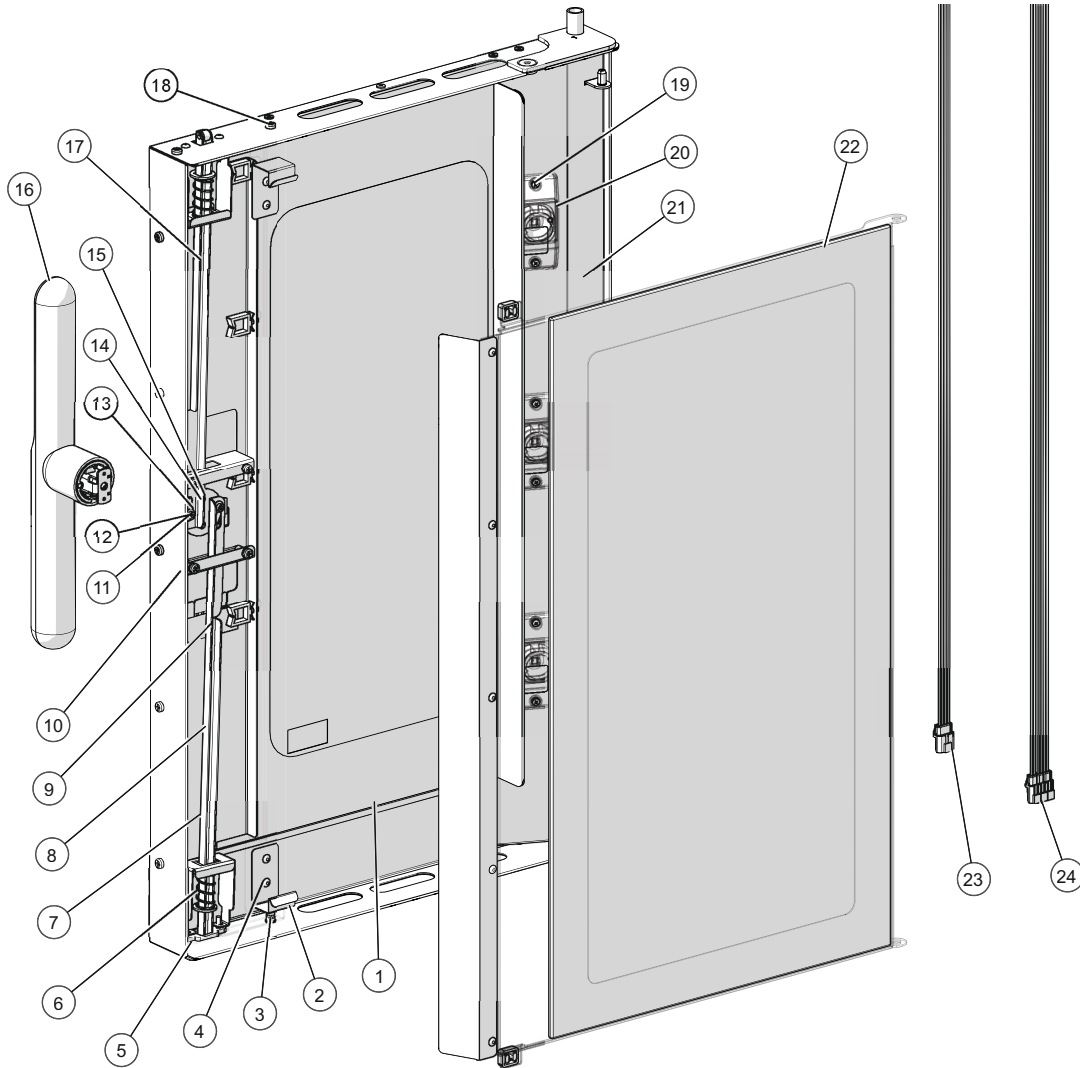

ID	Part No.	Description
1	TA-24637	TAPE, DOUBLE SIDED, 2.71FT
2	LT-47300	LATCH, INNER GLASS
3	SC-37702	SCREW, M4 X 12MM SEMS
4	RI-38125	RIVET,SEALED,.125", G.R. .039"-0.118"
5	RI-38404	RIVET,SEALED,.125", G.R. 0.197" - 0.276"
6	5032382	ASM, LF DOOR LATCH COVER VF3
7	5032384	ASSY, LATCH PLATE, LF VF3
8	5029395	LATCH, LH VF3 LOWER DOOR ASM
9	TA-38589	LINERLESS SPLICING TAPE .75"
10	BU-36038	3/8" BUSHING, SPLIT
11	SC-46521	SCREW, M3X0.5X4MM SCH
12	WS-22293	WASHER, FLAT
13	5032808	SPACER, DOOR ASSY, WELDMENT
14	SC-47301	SCREW,FLAT HEAD PHILPS M3-4MM
15	SC-22273	SCREW,M4x0.7X10MM PAN
16	HD-39991R	HANDLE, MULTI-PT LATCH W/LIGHT
17	5029394	LATCH, LH VF3 UPPER DOOR ASM
18	RI-27108	RIVET, SEALED
19	SC-22268	SCREW,M3x0.5X8MM PAN
20	5028680	LIGHT, CABINET LED
21	GS-23622	GASKET @ 1.83 Ft
22	5032378	ASSY, DOOR, INNER, LF VF3
23	CB-46182	CABLE HARNESS,HANDLE LIGHT,54"
24	CB-46688	CABLE HARNESS,CAVITY LIGHT,44"

Right Door Assembly (Simple and Deluxe)—F3G

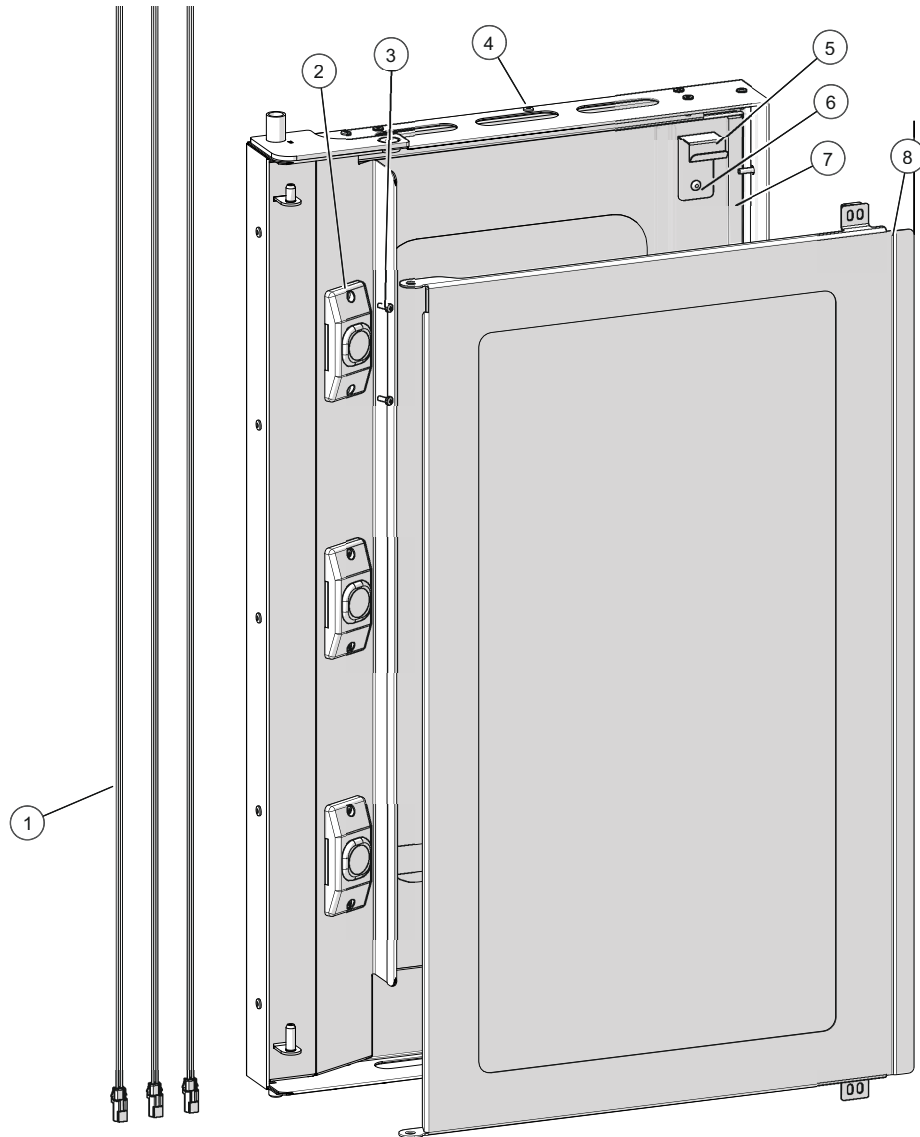

ID	Part No.	Description
1	CB-46690	CABLE HARNESS,CAVITY LIGHT,89"
2	5028680	LIGHT, CABINET LED
3	SC-22268	SCREW,M3x0.5X8MM PAN
4	RI-27108	RIVET, SEALED
5	LT-47300	LATCH, INNER GLASS
6	RI-38125	RIVET,SEALED,.125"
7	GS-23622	GASKET @ 1.83 Ft
8	5032375	ASSY, DOOR, INNER, RT VF3

Left Door Assembly, Simple—F4G

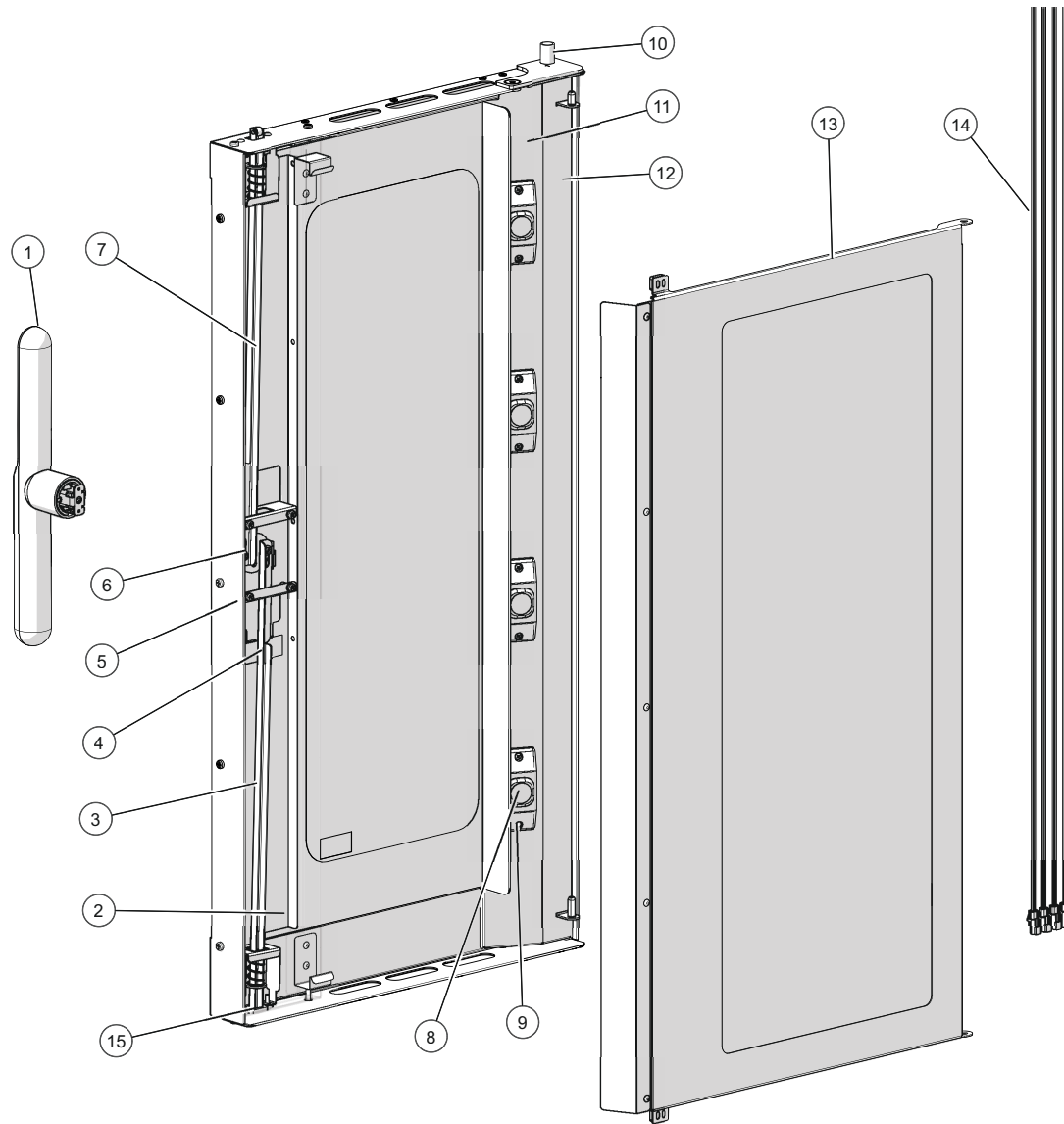

ID	Part No.	Description
1	HD-46826R	HANDLE, MULTI-PT LATCH NO LED
2	5032398	ASM, LATCH PLATE, LF VF4
3	5029398	LATCH, LH VF4 LOWER DOOR ASM
4	TA-38589	LINERLESS SPLICING TAPE .75"
5	BU-36038	3/8" BUSHING, SPLIT
6	5032808	SPACER, DOOR ASSY, WELDMNT
7	5029397	LATCH, LH VF4 UPPER DOOR ASM
8	5028680	LIGHT, CABINET LED
9	SC-22268	SCREW,M3x0.5X8MM PAN
10	1029501	PIN, UPPER HINGE, VOLPI F
11	5028933	BRACE, HINGE SIDE ASM VF4L
12	GS-23622	GASKET @ 2.43 Ft
13	5032394	ASSY,DOOR,INNER, LF VF4
14	CB-46688	CABLE HARNESS,CAVITY LIGHT,44"
15	1023790	GUIDE,LATCHING SYSTEM TOP/BOT

Left Door Assembly, Deluxe—F4G

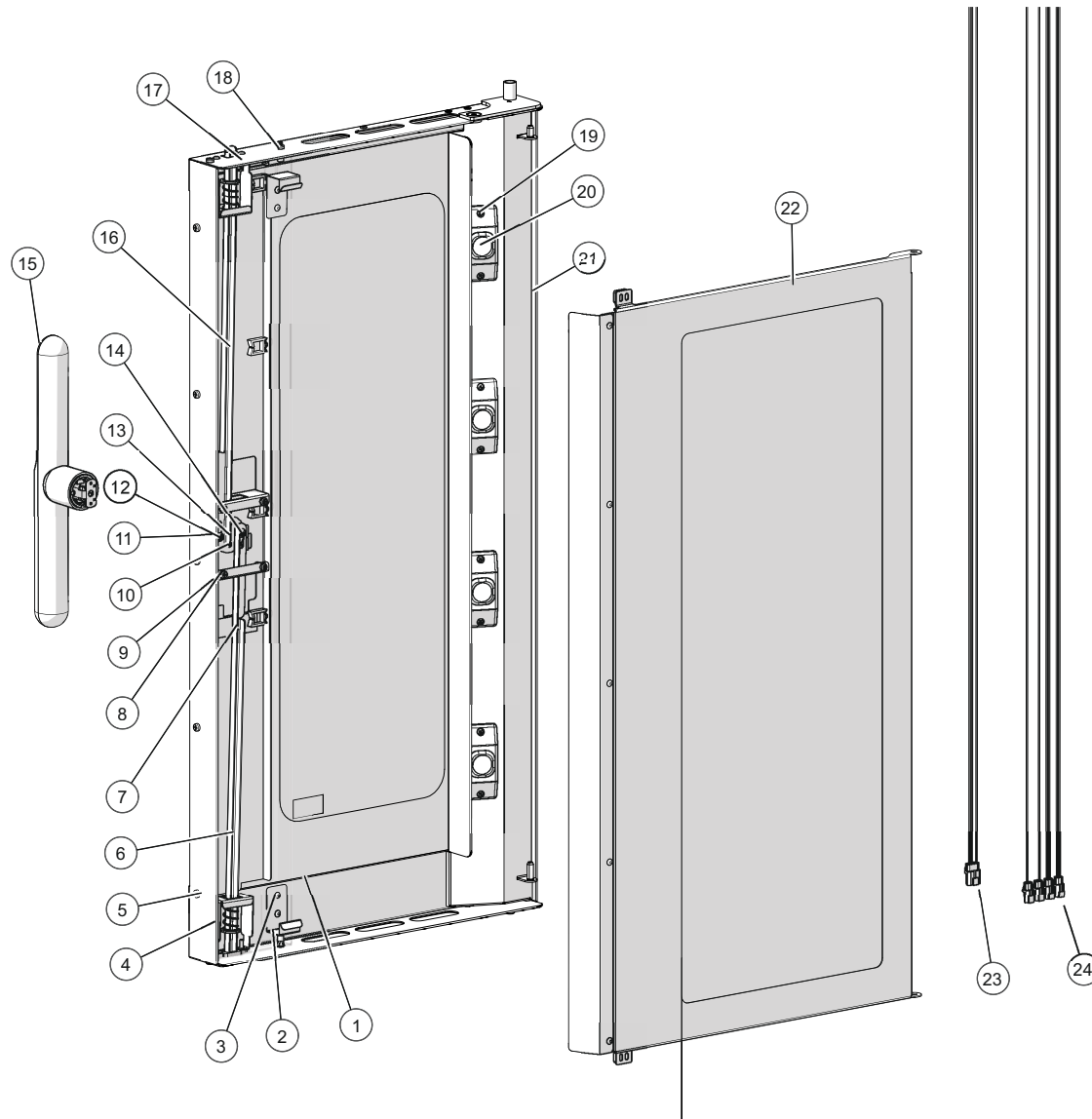

ID	Part No.	Description
1	TA-24637	TAPE, DOUBLE SIDED, 2.71FT
2	LT-47300	LATCH, INNER GLASS
3	RI-38125	RIVET,SEALED,.125"
4	5032400	ASM, LF DOOR LATCH COVER VF4
5	SC-37702	SCREW, M4 X 12MM SEMS
6	5029398	LATCH, LH VF4 LOWER DOOR ASM
7	TA-38589	LINERLESS SPLICING TAPE .75"
8	SC-37702	SCREW, M4 X 12MM SEMS
9	BU-36038	3/8" BUSHING, SPLIT
10	SC-47301	SCREW,FLAT HEAD PHILPS M3-4MM
11	SC-22273	SCREW,M4x0.7X10MM PAN
12	WS-22293	WASHER, FLAT
13	5028305	WELD ASSY, HANDLE ADAPTER
14	SC-46521	SCREW, M3X0.5X4MM SCH
15	HD-39991R	HANDLE, MULTI-PT LATCH W/LIGHT
16	5029397	LATCH, LH VF4 UPPER DOOR ASM
17	RI-38404	RIVET,SEALED,0.125 X 0.54
18	RI-27108	RIVET, SEALED, 0.125 X 0.46
19	SC-22268	SCREW,M3x0.5X8MM PAN
20	5028680	LIGHT, CABINET LED
21	GS-23622	GASKET @ 2.43 Ft
22	5032394	ASSY,DOOR,INNER, LF VF4
23	CB-46182	CABLE HARNESS,HANDLE LIGHT,54"
24	CB-46688	CABLE HARNESS,CAVITY LIGHT,44"

Right Door Assembly (Simple and Deluxe)—F4G

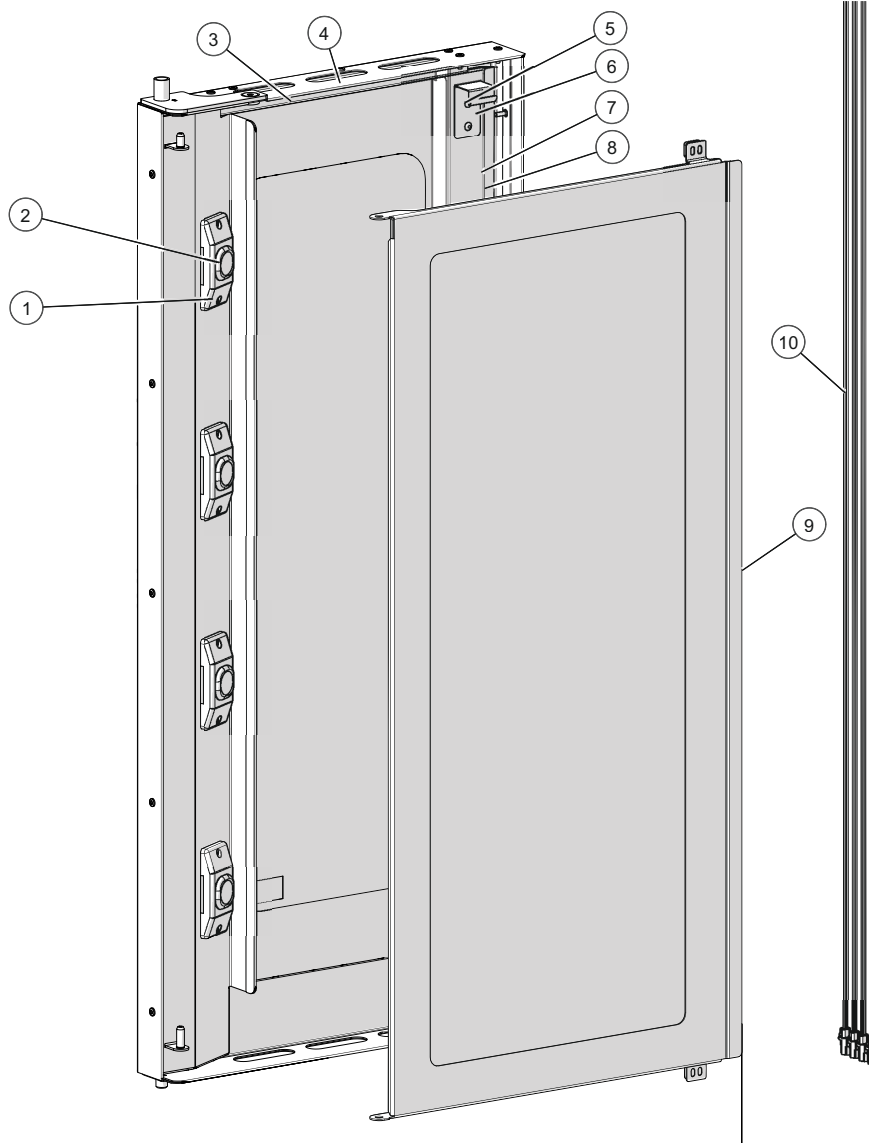

ID	Part No.	Description
1	SC-22268	SCREW,M3x0.5X8MM PAN
2	5028680	LIGHT, CABINET LED
3	TA-24637	TAPE, DOUBLE SIDED, 4.53FT
4	1029138	DOOR CABLE RUNNER, VOLPI FULL
5	RI-38125	RIVET,SEALED,.125"
6	LT-47300	LATCH, INNER GLASS
7	1035577	BRACE, RT DOOR, VF4
8	GS-23622	GASKET @ 2.43 Ft
9	5032396	ASSY,DOOR,INNER, RF VF4
10	CB-46690	CABLE HARNESS,CAVITY LIGHT,89"

Control Assembly, Simple—F3G

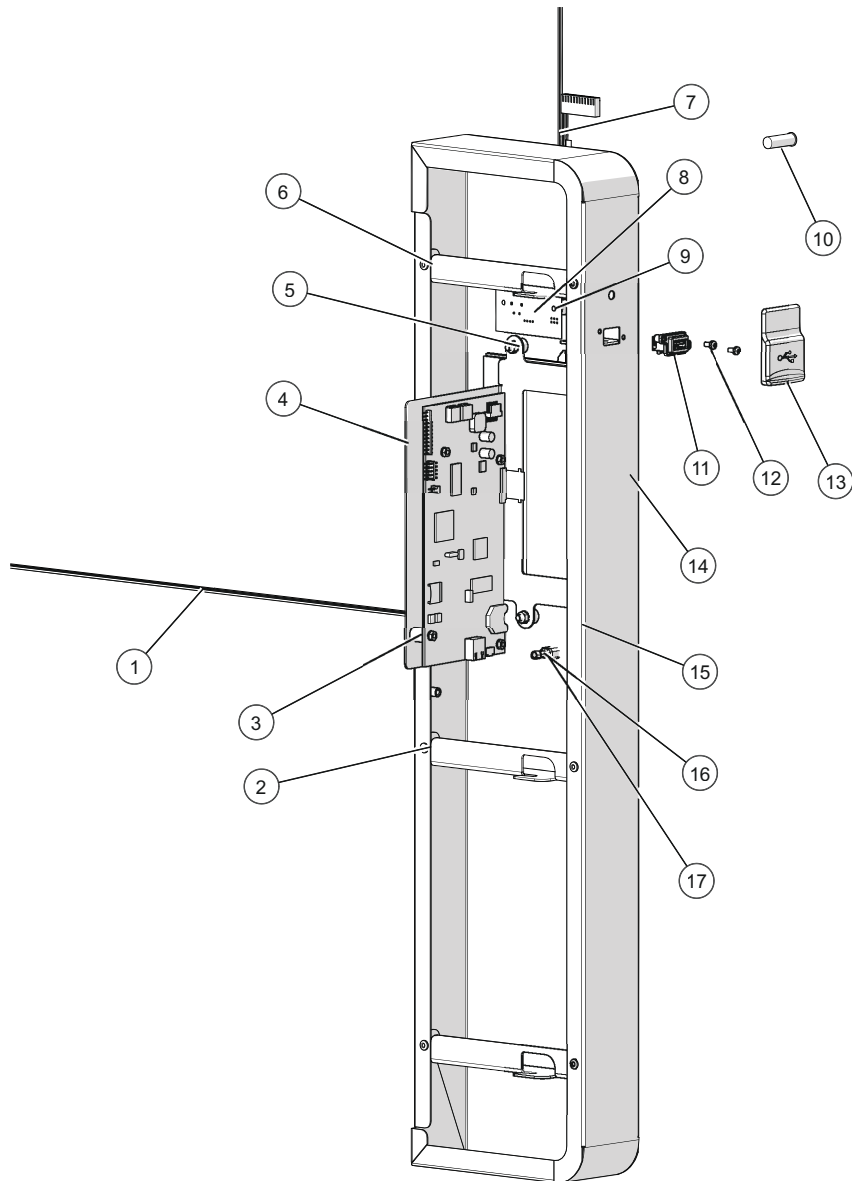

ID	Part No.	Description
1	CB-39169	CABLE, USER INTERFACE
2	RI-27108	RIVET, SEALED
3	BU-25094	BUSHING,*CT,ML,BRASS,DISTANCE
4	5032371R	LCD,IB COMB
5	BU-37710	BUSHING, BRASS, .280X .394
6	NU-26866	NUT, HEX INSERT M4
7	CB-39168	CABLE, ON OFF SWITCH
8	CC-36871	BOARD, ON/OFF, ONE BUTTON
9	NU-35846	NUT, KEPS, M3X0.5, SS
10	LI-37681R	LED, PANEL MOUNT 125/250V
11	BA-39847	BOARD,USB RECEPTACLE
12	SC-22266	SCREW,M3x0.5X6MM PAN
13	CP-39848	CAP,USB
14	5031516	SERVICE KIT, F3 SIMPLE CONTROL
15	NU-36319	NUT, M4, KEPS, ZINC PLATED
16	CR-34639	CONNECTOR, QUICK DISCONNECT
17	CC-46758R	MICRO SD CARD,W/FIRMWARE

Control Assembly, Deluxe—F3G

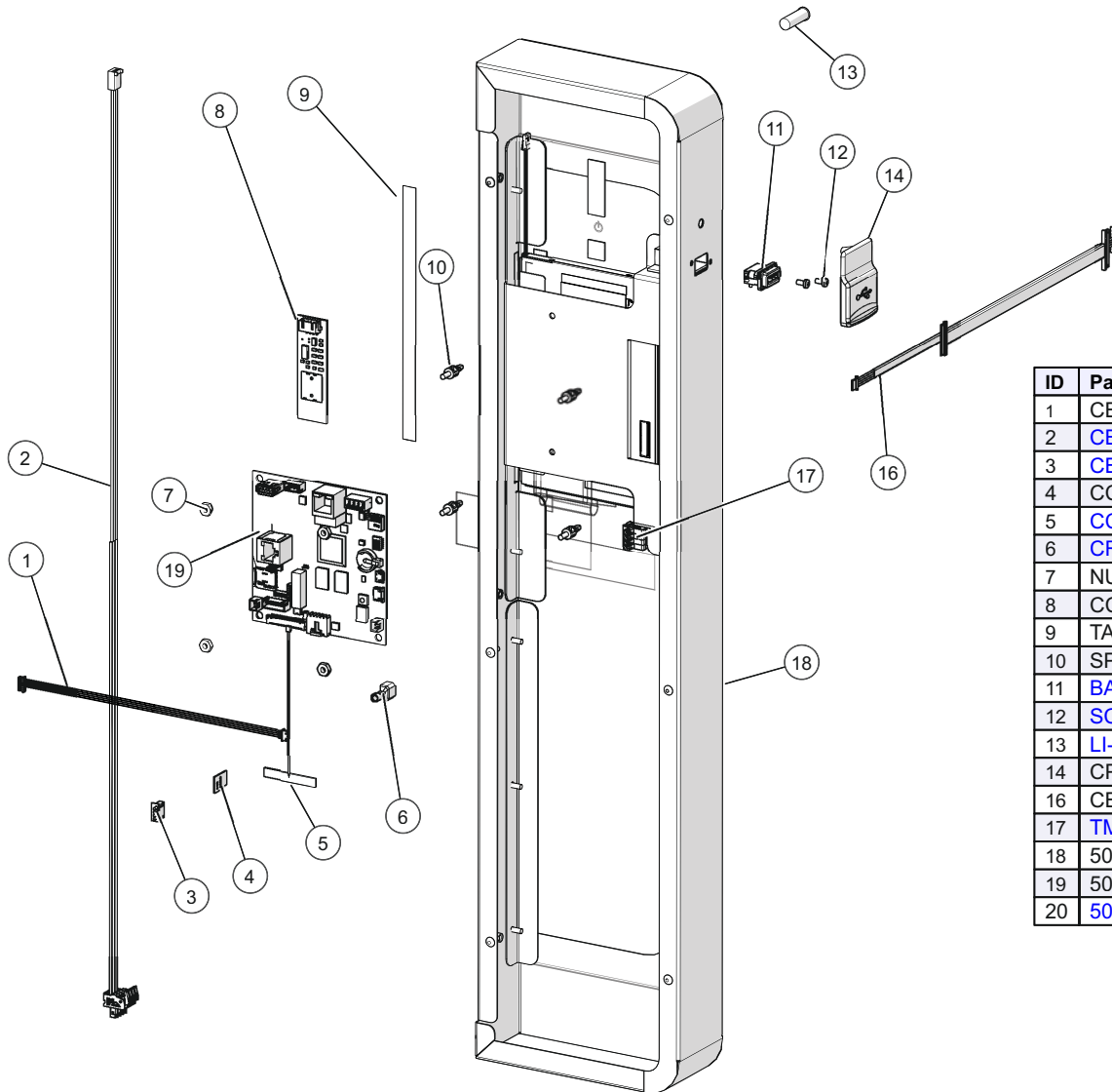

ID	Part No.	Description
1	CB-39912	CABLE,PCAP
2	CB-39703	CABLE, USER INTERFACE TO CB
3	CB-34917	CABLE,ON-OFF/BOARD,TOUCH
4	CC-46028R	CONTROL, CARD W/ PROGRAM
5	CC-46559	ANTENNA, WIFI CONTROL
6	CR-34639	CONNECTOR, QUICK DISCONNECT
7	NU-39735	NUT,HEX,6-32,NYLON
8	CC-39975	BOARD,ON/OFF BUTTON,PCAP
9	TA-46558	TAPE,SHIELDING,COND., 7" LONG
10	SP-33902	SPACER, 1/4", CIRCUIT BRD
11	BA-39847	BOARD,USB RECEPTACLE
12	SC-22266	SCREW,M3x0.5X6MM PAN
13	LI-37681R	LED, PANEL MOUNT 125/250V
14	CP-39848	CAP,USB
16	CB-46664	CABLE, LVDS & BL, AMPIRE
17	TM-34881	TERMINAL, 3.5MM PLUGGABLE, 4 POLE
18	5030668	CONTROL ASSEMBLY
19	5028178	BOARD,INTERFACE,VARIOUS
20	5030518	ETHERNET KIT (optional; not shown)

Control Assembly, Simple—F4G

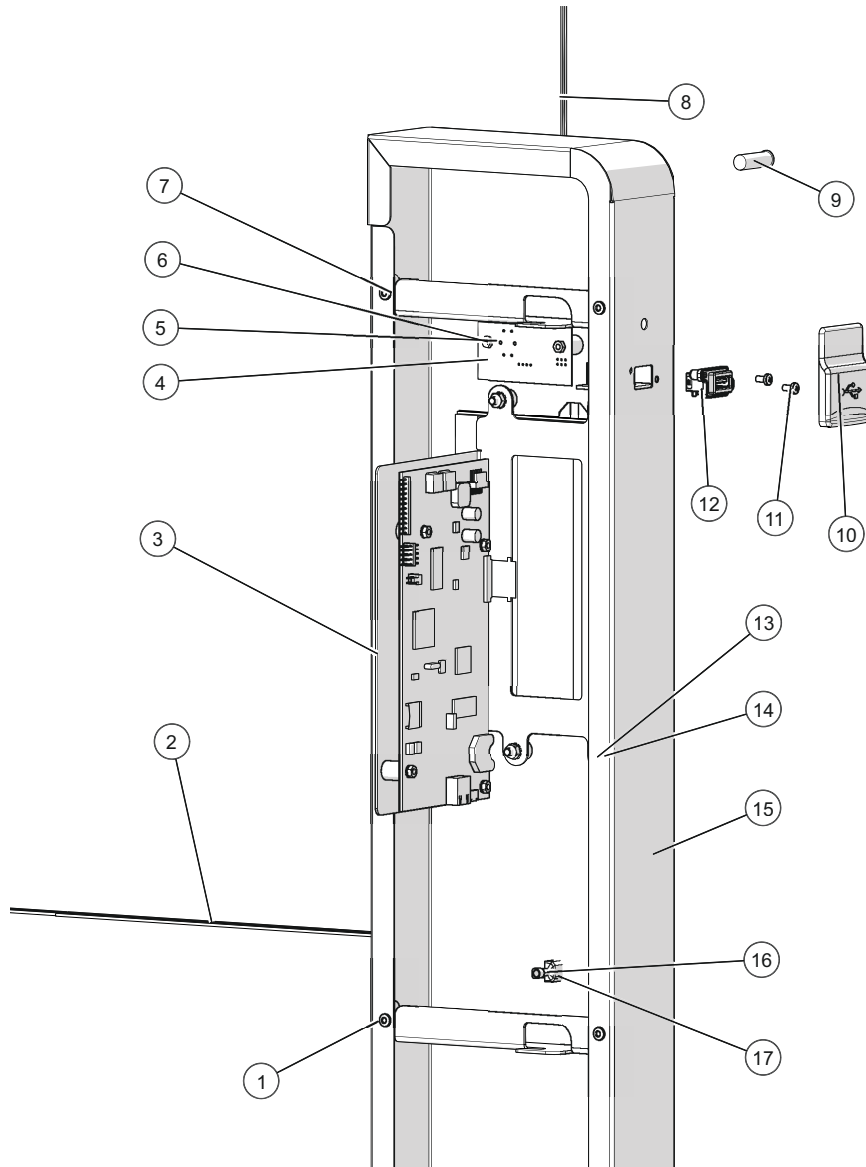

ID	Part No.	Description
1	NU-26866	NUT, HEX INSERT M4
2	CB-39169	CABLE, USER INTERFACE
3	5032371R	LCD,IB COMB
4	CC-36871	BOARD, ON/OFF, ONE BUTTON
5	BU-25094	BUSHING,*CT,ML,BRASS,DISTANCE
6	NU-35846	NUT, KEPS, M3X0.5, SS
7	RI-27108	RIVET, SEALED
8	CB-39168	CABLE, ON OFF SWITCH
9	LI-37681R	LED, PANEL MOUNT 125/250V
10	CP-39848	CAP,USB
11	SC-22266	SCREW,M3x0.5X6MM PAN
12	BA-39847	BOARD,USB RECEPTACLE
13	NU-36319	NUT, M4, KEPS, ZINC PLATED
14	BU-37710	BUSHING, BRASS, .280X .394
15	5028817	CONTROL SIMPLE WELDMENT VF4
16	CR-34639	CONNECTOR, QUICK DISCONNECT
17	CC-46758R	MICRO SD CARD W/FIRMWARE

Control Assembly, Deluxe—F4G

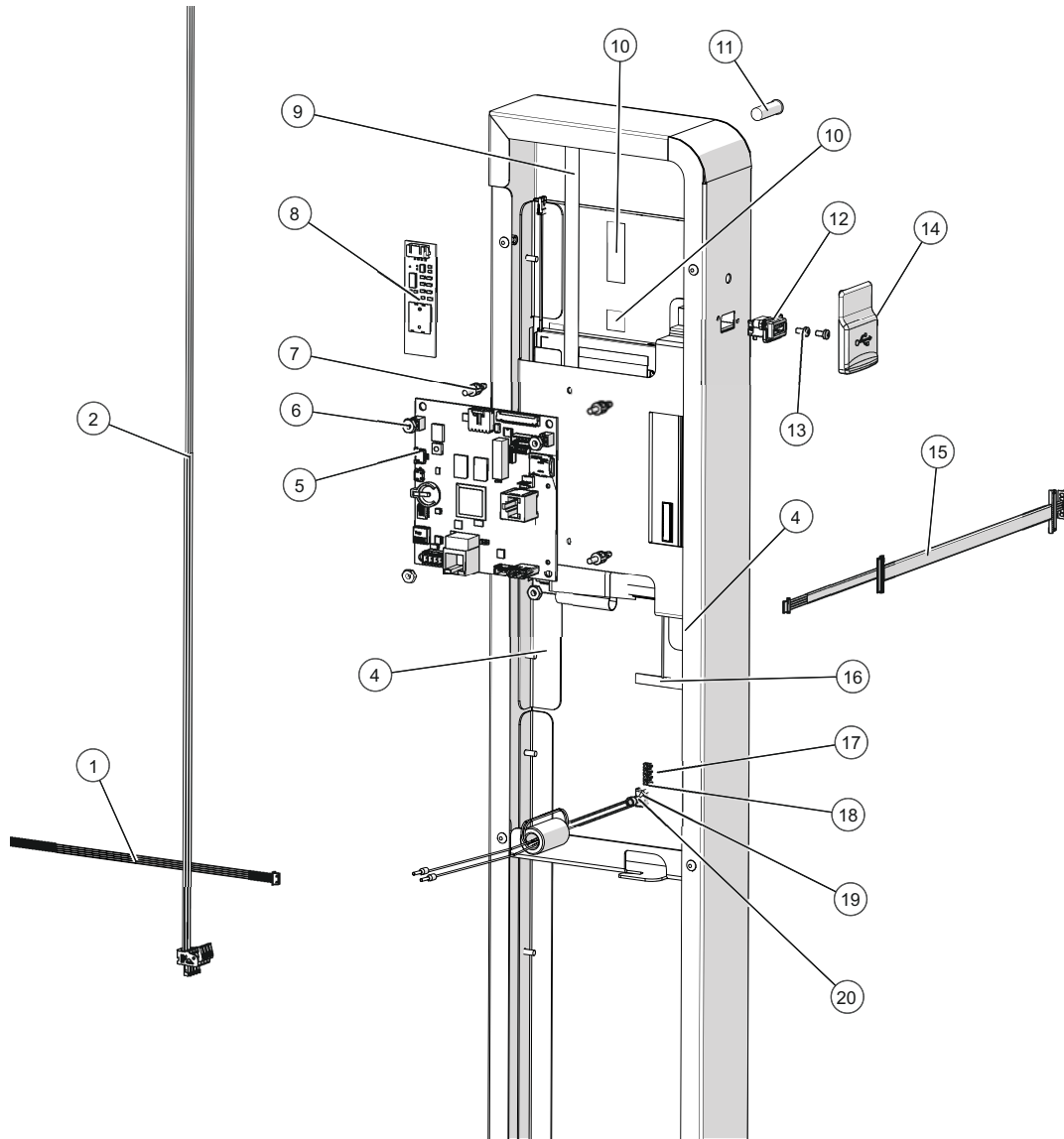

ID	Part No.	Description
1	CB-39912	CABLE,PCAP
2	CB-39703	CABLE, USER INTERFACE TO CB
4	TA-24637	1/2" VHB TAPE
5	5028178	SERVICE KIT, IB W/WIFI ANTENNA
6	NU-39735	NUT,HEX,6-32,NYLON
7	SP-33902	SPACER, 1/4", CIRCUIT BRD
8	CC-39975	BOARD,ON/OFF BUTTON,PCAP
9	TA-46558	TAPE,SHIELDING,COND., 7" LONG
10	TA-46816	1/2" VHB TAPE,1mm THK
11	LI-37681R	LED, PANEL MOUNT 125/250V
12	BA-39847	BOARD,USB RECEPTACLE
13	SC-22266	SCREW,M3x0.5X6MM PAN
14	CP-39848	CAP,USB
15	CB-46664	CABLE, LVDS & BL, AMPIRE
16	CC-46559	ANTENNA, WIFI CONTROL
17	TM-34881	TERMINAL, 3.5MM PLUGGABLE, 4 POLE
18	CB-34917	CABLE,ON-OFF/BOARD,TOUCH
19	CC-46028R	CONTROL, CARD W/ PROGRAM
20	CR-34639	CONNECTOR, QUICK DISCONNECT
21	5030518	ETHERNET KIT (optional; not shown)

Electrical Package, 120V—F3G

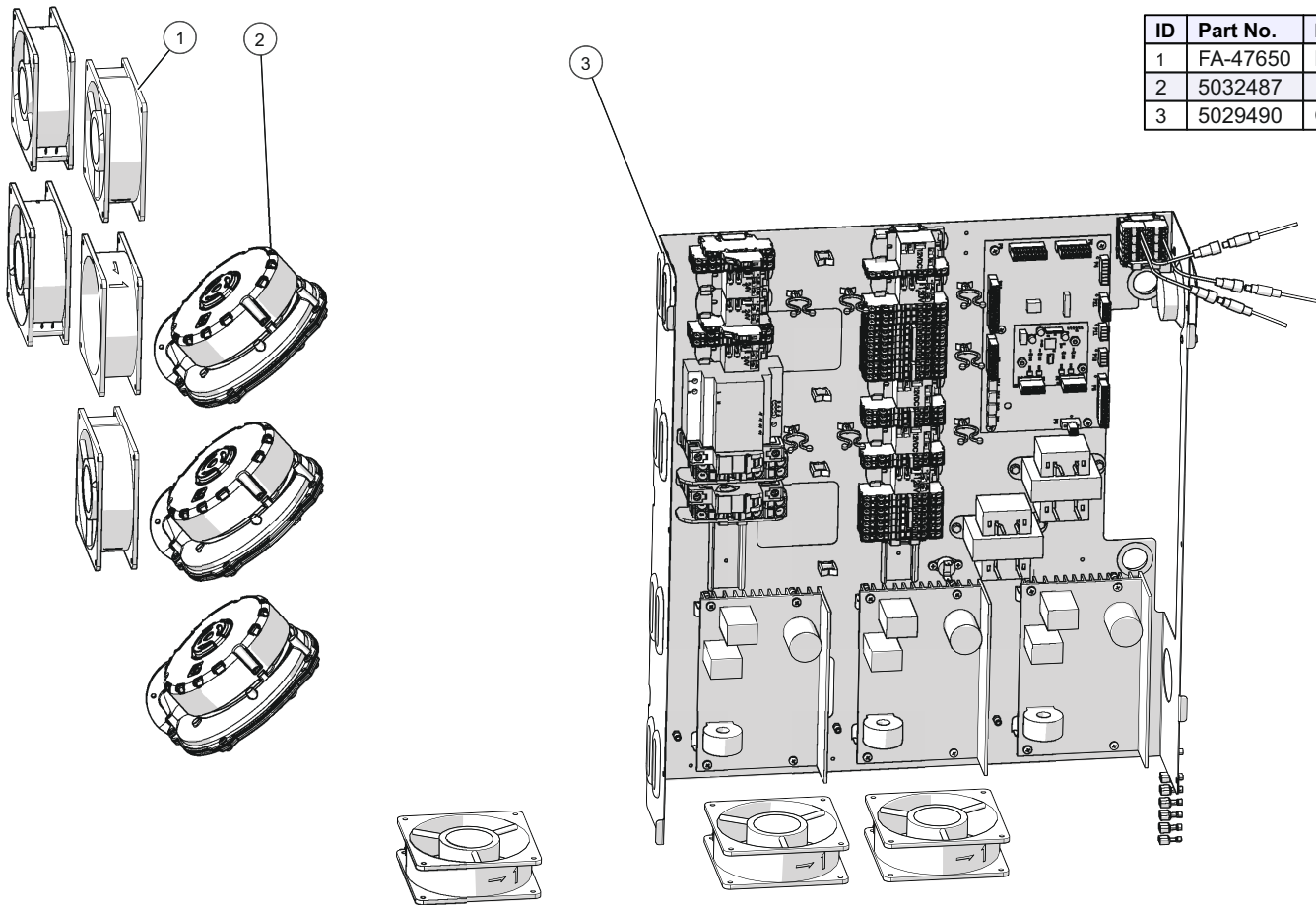

ID	Part No.	Description
1	FA-47650	FAN,115V,50/60HZ
2	5032487	KIT, COMBUSTION BLOWER 120V
3	5029490	CHASSIS,ELEC ASSEM,F3 GAS 120V

Electrical Chassis, 120V—F3G

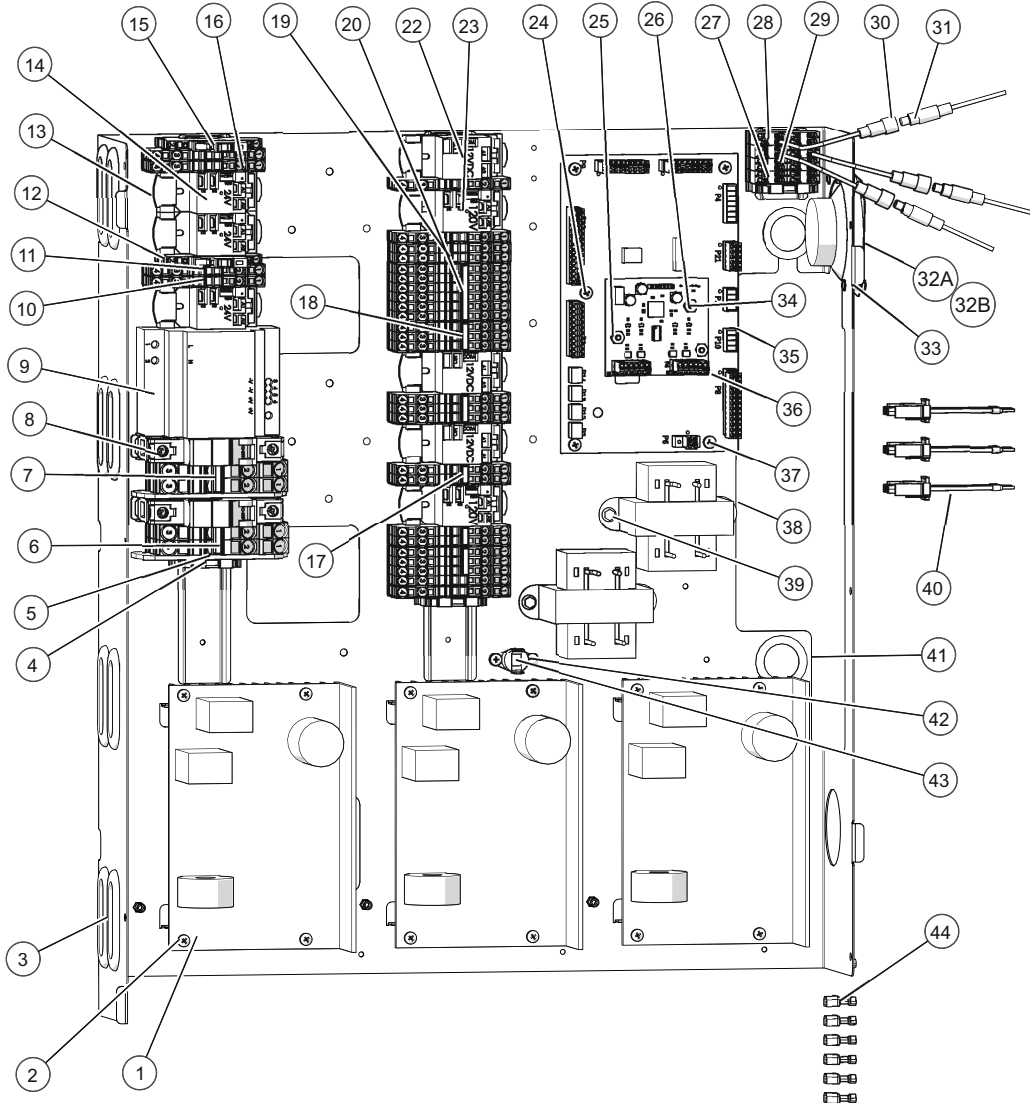

ID	Part No.	Description
1	BA-46311	CONTROLLER,120V,W/HEATSINK
2	SC-29276	SCREW,M4x0.7X30MM PAN
3	GS-46746	GROMMET, WIRE, 1-3/8"IDX2"OD
4	TM-39606	TERMINAL, SCREWLESS END
5	TM-37726	TERMINAL, 10MM END
6	TM-37660	TERMINAL, 10mm, ORANGE, SPRING
7	TM-37727	JUMPER BAR 2 POLE
8	FU-39058	CIRCUIT BREAKER, 20A
9	BA-46801	POWER SUPPLY, 12VDC, 100W
10	TM-39574	TERMINAL, 6mm, ORANGE, SPRING
11	TM-39575	TERMINAL, 6mm, BLUE, SPRING
12	FU-33184	5X20MM, SLOW BLO, 2 AMP, 250V
13	TM-37674	T BLOCK, RELAY MOUNT
14	RL-39901	RELAY, 40AMP MIN POWER 24V
15	TM-39577	TERMINAL, FUSE HOLDER,
16	TM-39576	TERMINAL, END SECTION, SPRING
17	TM-39585	JUMPER, 2 POLE
18	TM-39584	JUMPER, 3 POLE
19	TM-39579	TERMINAL,GROUND, 6mm, SPRING
20	TM-46073	JUMPER, 6 POLE
22	RE-37704	RELAY, 12VDC
23	RL-46318	RELAY, 40AMP MIN POWER 120V
24	SC-35729	SCREW,M4x0.7X8MM PAN
25	SC-46084	SCREW,NYLON 6-32 X 1/4"
26	ST-46083	SPACER,M/F HEX STANDOFF 6/32
27	TM-46689	TERMINAL, DIST BLOCK WHITE
28	TM-46667	TERMINAL, DIST BLOCK BLACK
29	TM-46668	TERMINAL, SUPPORT BRACKET
30	FU-36762	IN-LINE FUSE HOLDER, 5X20MM 150 SERIES
31	FU-46554	FUSE, 630mA, 250V,FAST ACTING,
32A	BZ-37655	SPEAKER W/LEADS, SIMPLE
32B	BZ-39711	SPEAKER W/LEADS, DELUXE
33	SC-37702	SCREW, M4 X 12MM SEMS
34	NU-39735	NUT,HEX,6-32,NYLON
35	CC-39528R	CONTROL BOARD SVC KIT
36	CC-46662	DAUGHTER BOARD,LVIO, PWM, SIT
37	WS-22300	WASHER, M4 SPLIT LOCK
38	TN-46026	TRANSFORMER,120V-24V,50VA
39	SC-39147	SCREW, 8-18 X .480 HEX WASHER
40	5032252	CABLE, COMBUSTION POWER 3 PIN
41	BU-37626	1-1/4" SNAP BUSHING
42	SC-38693	SCREW, #8-18 X 1/2", PHIL, PAN
43	TT-37680	THERMOSTAT,AUTO RESET,
44	CR-34639	CONNECTOR, QUICK DISCONNECT
45	5032250	WIRE ASSEMBLY, FAN CONNECTOR (not shown)
46	5032287	CABLE,COOLING FAN HIGH LIMIT (not shown)
47	CB-47267	CABLE, BOARD TO BLOWER 46" (not shown)

Electrical Package, 220V—F3G

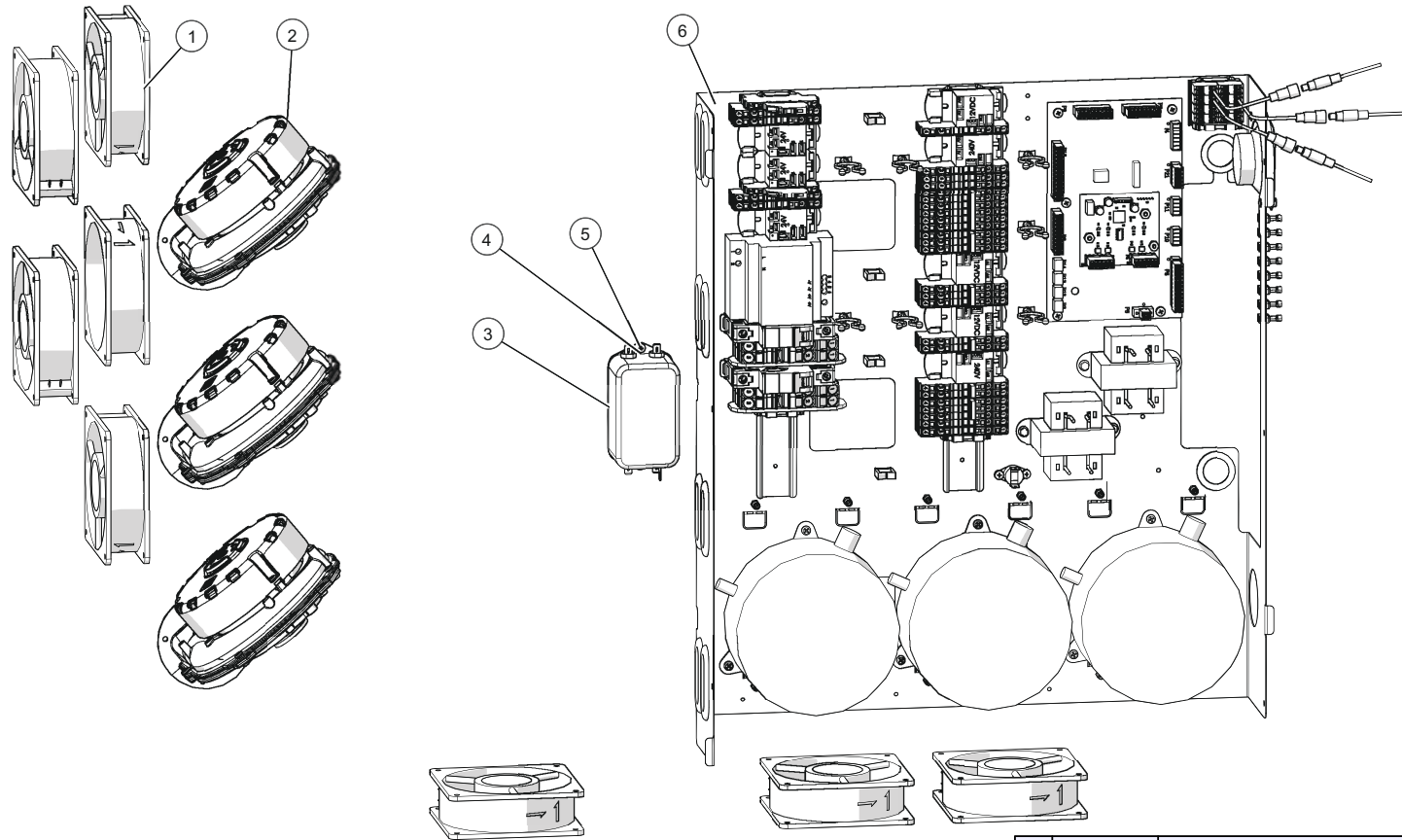

ID	Part No.	Description
1	FA-47651	FAN,230V,MECHATRONICS,HI-TEMP
2	5032488	KIT, COMBUSTION BLOWER 230V
3	FI-46392	FILTER, TWO STAGE 250VAC
4	NU-26866	NUT, HEX INSERT M4
5	SC-22273	SCREW,M4x0.7X10MM PAN
6	5029492	CHASSIS,ELEC ASSEM,F3 GAS 220V (see detail view)

Electrical Chassis, 220V—F3G

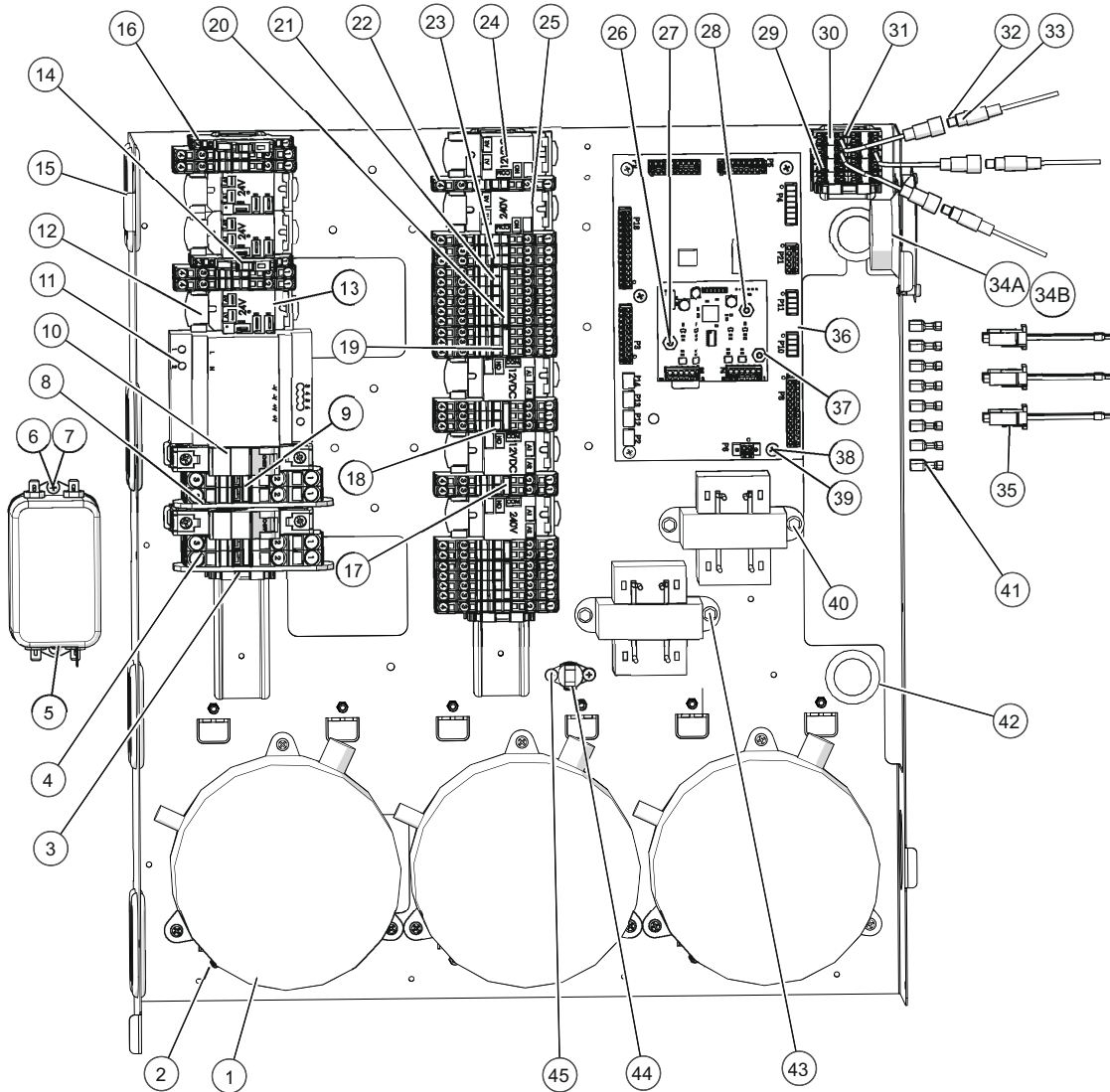

ID	Part No.	Description
1	BA-39727	BOARD CONTROLLER, TELCO
2	SC-37702	SCREW, M4 X 12MM SEMS
3	TM-39606	TERMINAL, SCREWLESS END
4	TM-37660	TERMINAL, 10mm, ORANGE, SPRING
5	FI-46392	FILTER, TWO STAGE 250VAC
6	SC-22273	SCREW, M4x0.7X10MM PAN
7	NU-26866	NUT, HEX INSERT M4
8	TM-37726	TERMINAL, 10MM END
9	TM-37727	JUMPER BAR 2 POLE
10	FU-39058	CIRCUIT BREAKER, 20A
11	BA-46801	POWER SUPPLY, 12VDC, 100W
12	TM-37674	T BLOCK, RELAY MOUNT
13	RL-39901	RELAY, 40AMP MIN POWER 24V
14	TM-39577	TERMINAL, FUSE HOLDER,
15	GS-46746	GROMMET, WIRE, 1-3/8"IDX2"OD
16	FU-33184	5X20MM, SLOW BLO, 2 AMP, 250V
17	TM-39585	JUMPER, 2 POLE
18	TM-39576	TERMINAL, END SECTION, SPRING
19	TM-39584	JUMPER, 3 POLE
20	TM-46073	JUMPER, 6 POLE
21	TM-39574	TERMINAL, 6mm, ORANGE, SPRING
22	TM-39575	TERMINAL, 6mm, BLUE, SPRING
23	TM-39579	TERMINAL, GROUND, 6mm, SPRING
24	RE-37704	RELAY, 12VDC
25	RE-37725	RELAY, 240V AC
26	NU-39735	NUT, HEX, 6-32, NYLON
27	ST-46083	SPACER, M/F HEX STANDOFF 6/32
28	SC-46084	SCREW, NYLON 6-32 X 1/4"
29	TM-46689	TERMINAL, DIST BLOCK WHITE
30	TM-46667	TERMINAL, DIST BLOCK BLACK
31	TM-46668	TERMINAL, SUPPORT BRACKET
32	FU-36762	IN-LINE FUSE HOLDER, 5X20MM 150 SERIES
33	FU-46554	FUSE, 630mA, 250V, FAST ACTING,
34A	BZ-37655	SPEAKER W/LEADS, SIMPLE
34B	BZ-39711	SPEAKER W/LEADS, DELUXE
35	5032252	CABLE, COMBUSTION POWER 3 PIN
36	CC-39528R	CONTROL BOARD SVC KIT
37	CC-46662	DAUGHTER BOARD, LVIO, PWM, SIT
38	SC-35729	SCREW, M4x0.7X8MM PAN
39	WS-22300	WASHER, M4 SPLIT LOCK
40	TN-46388	TRANSFORMER, 240V-24V, 50VA
41	CR-34639	CONNECTOR, QUICK DISCONNECT
42	BU-37626	1-1/4" SNAP BUSHING
43	SC-39147	SCREW, 8-18 X .480 HEX WASHER
44	TT-37680	THERMOSTAT, AUTO RESET,
45	SC-38693	SCREW, #8-18 X 1/2", PHIL, PAN
46	5032250	WIRE ASSEMBLY, FAN CONNECTOR (not shown)
47	5032287	CABLE, COOLING FAN HIGH LIMIT (not shown)
48	CB-47267	CABLE, BOARD TO BLOWER 46" (not shown)

Electrical Package, 208-240V—F3G

ID	Part No.	Description
1	5031194	CHASSIS,ELEC,F3 GAS 208-240V (see detail view)
2	1033634	PANEL, BACK CAV, F3 GAS
3	FA-47651	FAN,230V,50/60HZ
4	5032488	KIT, COMBUSTION BLOWER, 230V

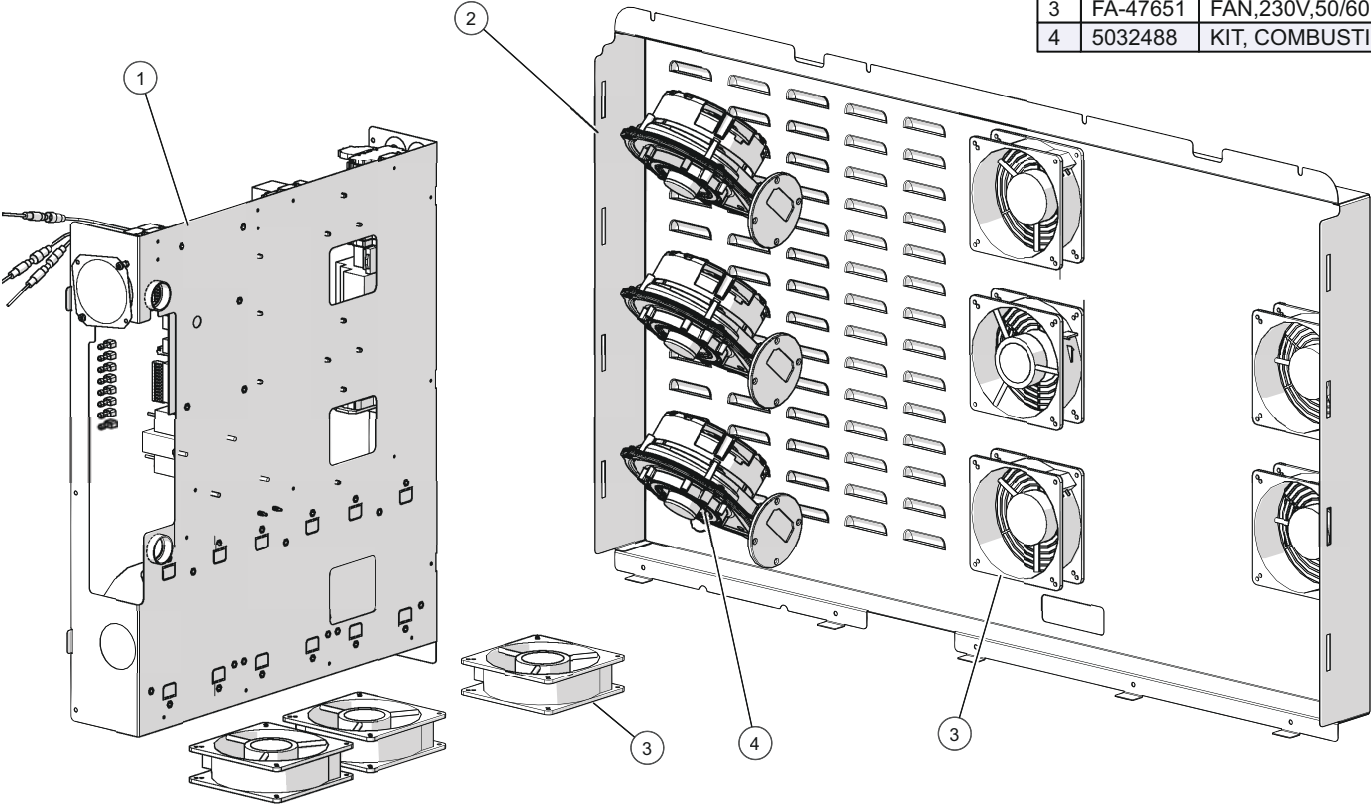

Electrical Chassis, 208-240V—F3G

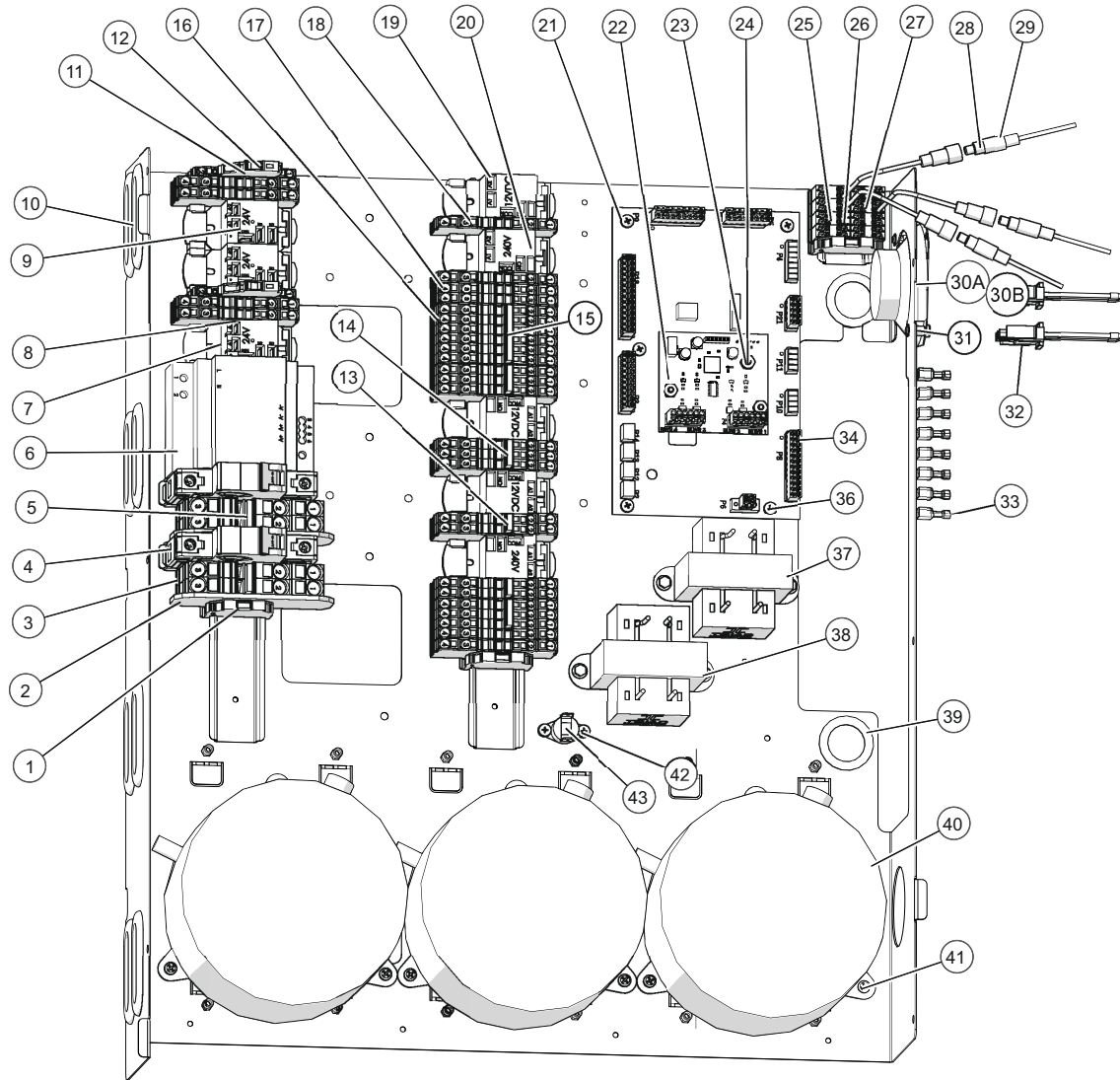

ID	Part No.	Description
1	TM-39606	TERMINAL, SCREWLESS END
2	TM-37726	TERMINAL, 10MM END
3	TM-37660	TERMINAL, 10mm, ORANGE, SPRING
4	FU-39058	CIRCUIT BREAKER, 20A
5	TM-37727	JUMPER BAR 2 POLE
6	BA-46801	POWER SUPPLY, 12VDC, 100W
7	RL-39901	RELAY, 40AMP MIN POWER 24V
8	TM-39576	TERMINAL, END SECTION, SPRING
9	TM-37674	T BLOCK, RELAY MOUNT
10	GS-46746	GROMMET, WIRE, 1-3/8"IDx2"OD
11	TM-39577	TERMINAL, FUSE HOLDER,
12	FU-33184	5X20MM, SLOW BLO, 2 AMP, 250V
13	TM-39585	JUMPER, 2 POLE
14	TM-39584	JUMPER, 3 POLE
15	TM-46073	JUMPER, 6 POLE
16	TM-39574	TERMINAL, 6mm, ORANGE, SPRING
17	TM-39579	TERMINAL, GROUND, 6mm, SPRING
18	TM-39575	TERMINAL, 6mm, BLUE, SPRING
19	RE-37704	RELAY, 12VDC
20	RE-37725	RELAY, 240V AC
21	SC-35729	SCREW, M4x0.7X8MM PAN
22	SC-46084	SCREW, NYLON 6-32 X 1/4"
23	ST-46083	SPACER, M/F HEX STANDOFF 6/32
24	NU-39735	NUT, HEX, 6-32, NYLON
25	TM-46689	TERMINAL, DIST BLOCK WHITE
26	TM-46668	TERMINAL, SUPPORT BRACKET
27	TM-46667	TERMINAL, DIST BLOCK BLACK
28	FU-46554	FUSE, 630mA, 250V, FAST ACTING,
29	FU-36762	IN-LINE FUSE HOLDER, 5X20MM 150 SERIES
30A	BZ-37655	SPEAKER W/LEADS, SIMPLE
30B	BZ-39711	SPEAKER W/LEADS, DELUXE
31	SC-37702	SCREW, M4 X 12MM SEMS
32	5032252	CABLE, COMBUSTION POWER 3 PIN
33	CR-34639	CONNECTOR, QUICK DISCONNECT
34	CC-39528R	SVC KIT, CONTROL BOARD
36	WS-22300	WASHER, M4 SPLIT LOCK
37	TN-46388	TRANSFORMER, 240V-24V, 50VA
38	SC-39147	SCREW, 8-18 X .480 HEX WASHER
39	BU-37626	1-1/4" SNAP BUSHING
40	BA-39727	BOARD CONTROLLER, TELCO
41	NU-26866	NUT, HEX INSERT M4
42	SC-38693	SCREW, #8-18 X 1/2", PHIL, PAN
43	TT-37680	THERMOSTAT, AUTO RESET,
44	CB-47267	CABLE, BOARD TO BLOWER 46" (not shown)

Chassis, Ignition Module—F3G

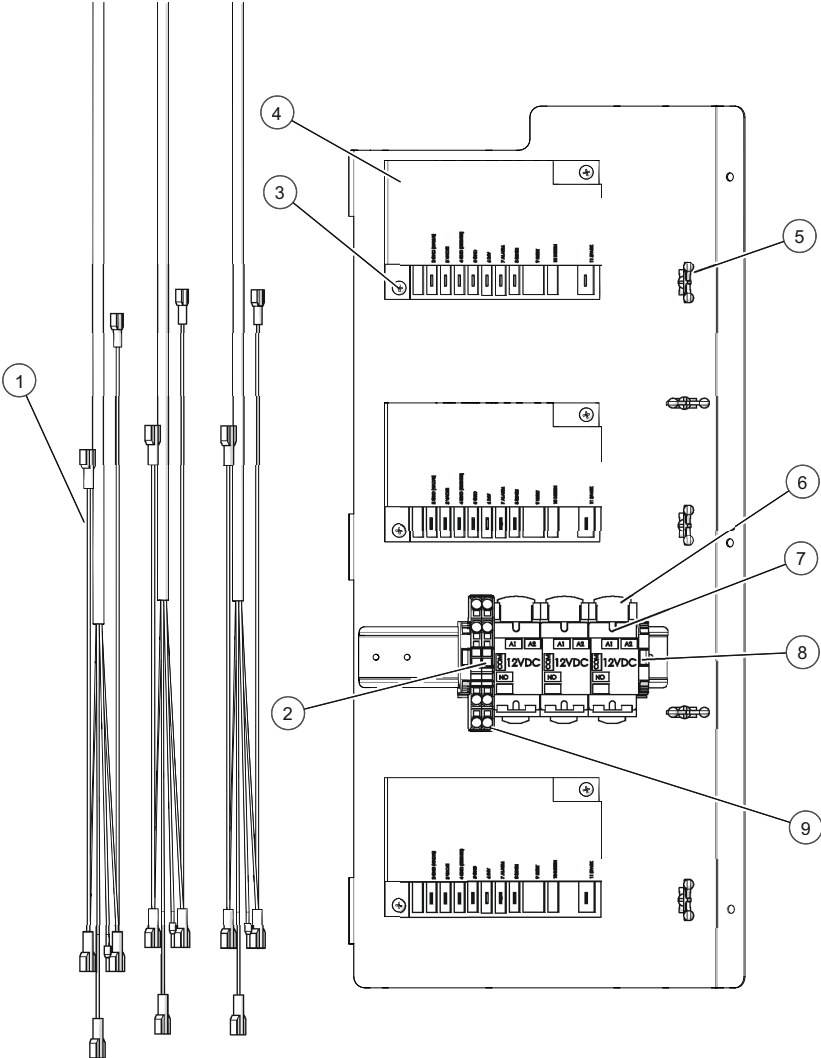

ID	Part No.	Description
1	CB-46078	CABLE, IGNITION MODULE 123"
2	TM-39579	TERMINAL,GROUND, 6mm, SPRING
3	SC-22765	SCREW,M4x0.7X20MM PAN
4	BA-46469	BOARD, IGNITION CONTROL
5	TI-35719	TIE, TWIST LOCK 0.5" STANDOFF
6	TM-37674	T BLOCK, RELAY MOUNT
7	RE-37704	RELAY, 12VDC
8	TM-39606	TERMINAL, SCREWLESS END
9	TM-39576	TERMINAL, END SECTION, SPRING
10	5032557	COMMON WIRE SET, F3G/F4G (not shown)

Electrical Package, 120V—F4G

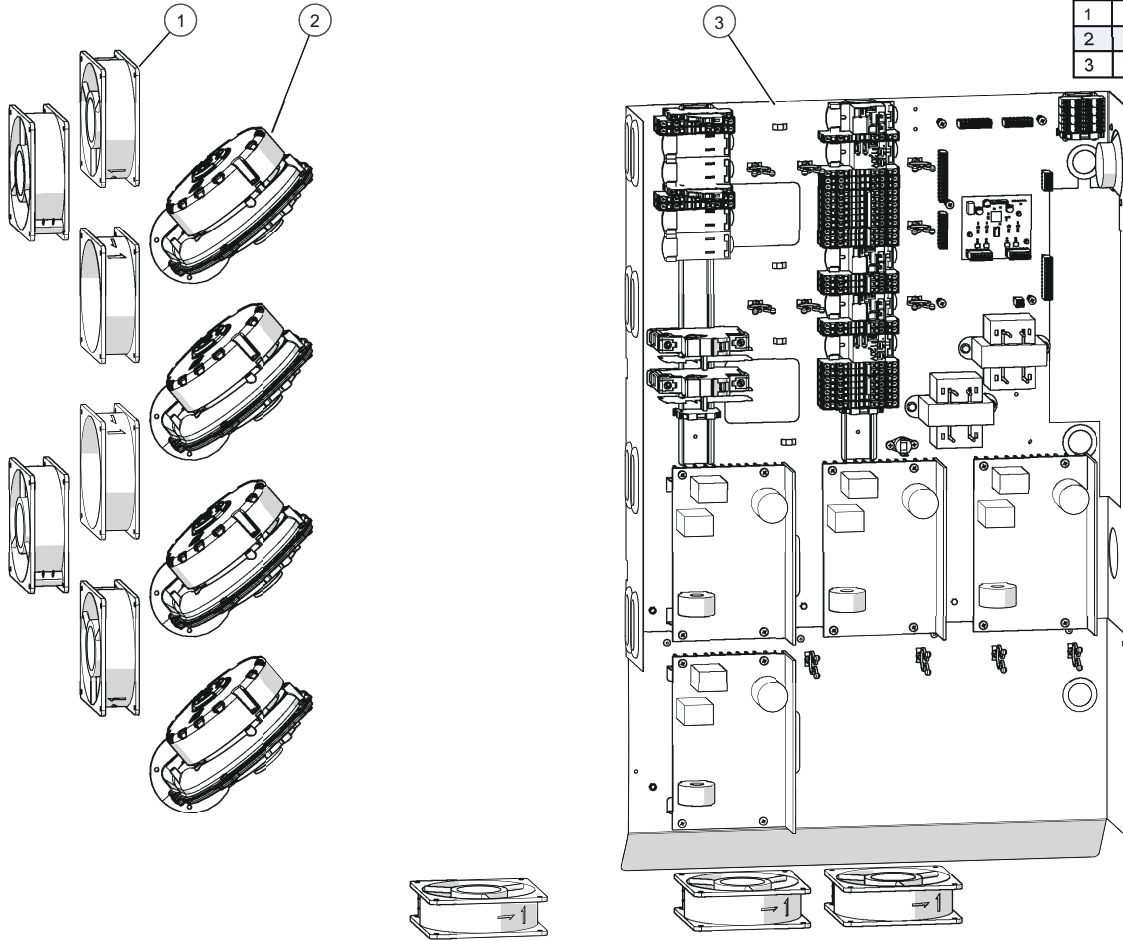

ID	Part No.	Description
1	FA-47650	FAN,115V,50/60HZ
2	5032487	KIT, COMBUSTION BLOWER 120V
3	5029153	CHASSIS,ELEC ASSEM,F4 GAS 120V (see detail view)

Electrical Chassis, 120V—F4G

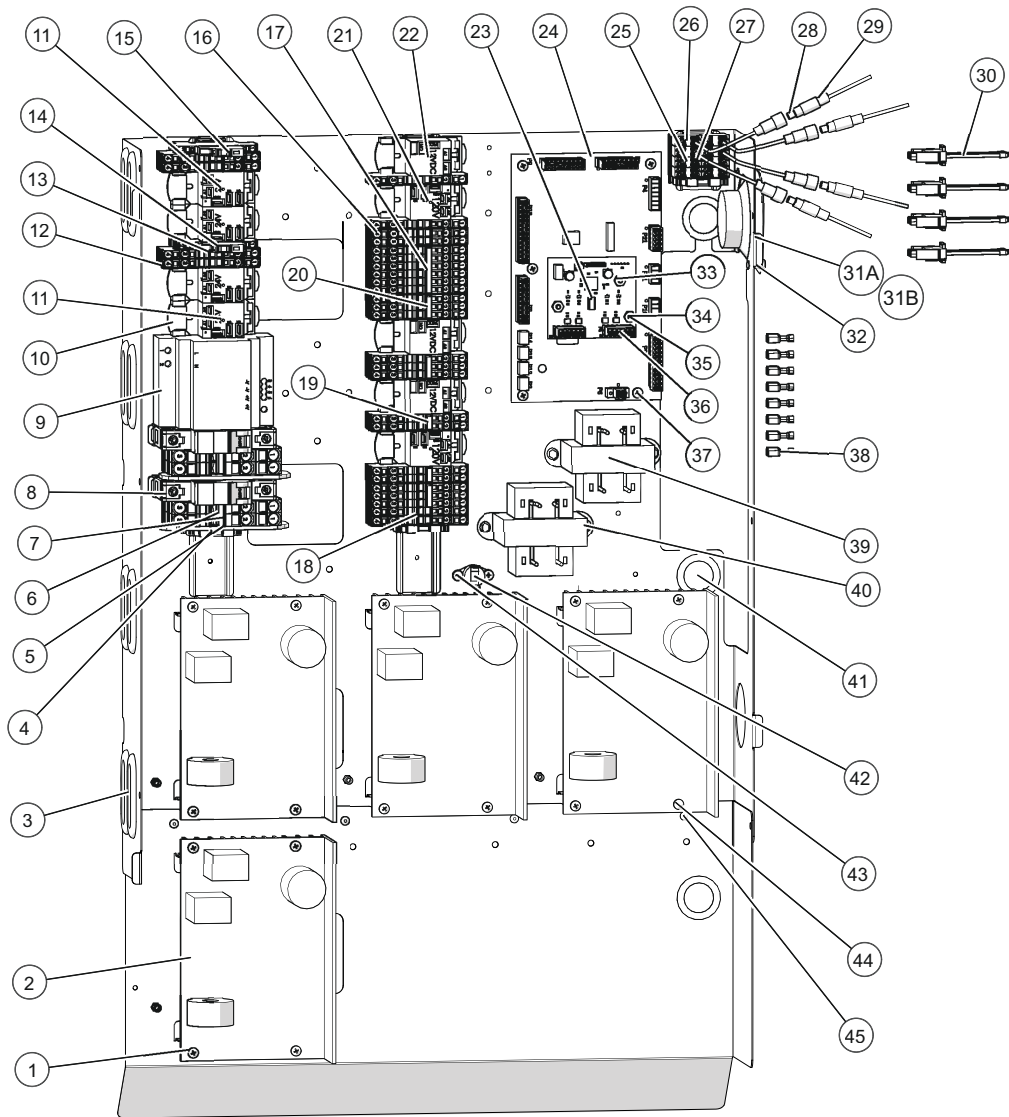

ID	Part No.	Description
1	NU-26866	NUT, HEX INSERT M4
2	BA-46311	CONTROLLER, 120V,W/HEATSINK
3	GS-46746	GROMMET, WIRE, 1-3/8"IDX2"OD
4	TM-39606	TERMINAL, SCREWLESS END
5	TM-37726	TERMINAL, 10MM END
6	TM-37727	JUMPER BAR 2 POLE
7	TM-37660	TERMINAL, 10mm, ORANGE, SPRING
8	FU-39058	CIRCUIT BREAKER, 20A
9	BA-46801	POWER SUPPLY, 12VDC, 100W
10	TM-37674	T BLOCK, RELAY MOUNT
11	RL-39901	RELAY, 40AMP MIN POWER 24V
12	TM-39574	TERMINAL, 6mm, ORANGE, SPRING
13	TM-39575	TERMINAL, 6mm, BLUE, SPRING
14	TM-39577	TERMINAL, FUSE HOLDER,
15	FU-33184	5X20MM, SLOW BLO, 2 AMP, 250V
16	TM-39579	TERMINAL, GROUND, 6mm, SPRING
17	TM-46073	JUMPER, 6 POLE
18	TM-39576	TERMINAL, END SECTION, SPRING
19	TM-39585	JUMPER, 2 POLE
20	TM-39584	JUMPER, 3 POLE
21	RL-46318	RELAY, 40AMP MIN POWER 120V
22	RE-37704	RELAY, 12VDC
23	CC-46662	DAUGHTER BOARD,LVIO, PWM, SIT
24	CC-39528R	CONTROL BOARD SVC KIT
25	TM-46689	TERMINAL, DIST BLOCK WHITE
26	TM-46667	TERMINAL, DIST BLOCK BLACK
27	TM-46668	TERMINAL, SUPPORT BRACKET
28	FU-46554	FUSE, 630mA, 250V,FAST ACTING,
29	FU-36762	IN-LINE FUSE HOLDER, 5X20MM 150 SERIES
30	5032252	CABLE, COMBUSTION POWER 3 PIN
31A	BZ-37655	SPEAKER,W/LEADS
31B	BZ-39711	SPEAKER W/LEADS, DELUXE
32	SC-37702	SCREW, M4 X 12MM SEMS
33	SC-46084	SCREW,NYLON 6-32 X 1/4"
34	ST-46083	SPACER,M/F HEX STANDOFF 6/32
35	NU-39735	NUT,HEX,6-32,NYLON
36	TM-47279	TERMINAL, CONNECTOR, 6 PIN
37	SC-35729	SCREW,M4x0.7X8MM PAN
38	CR-34639	CONNECTOR, QUICK DISCONNECT
39	TN-46026	TRANSFORMER, 120V-24V,50VA
40	SC-39147	SCREW, 8-18 X .480 HEX WASHER
41	BU-37626	1-1/4" SNAP BUSHING
42	TT-37680	THERMOSTAT,AUTO RESET,
43	SC-38693	SCREW, #8-18 X 1/2", PHIL, PAN
44	SC-29276	SCREW,M4x0.7X30MM PAN
45	RI-38125	RIVET,SEALED,.125"
46	5032250	WIRE ASSEMBLY, FAN CONNECTOR (not shown)
47	5032287	CABLE, COOLING FAN HIGH LIMIT (not shown)
48	CB-47267	CABLE, BOARD TO BLOWER 46" (not shown)

Electrical Package, 220V—F4G

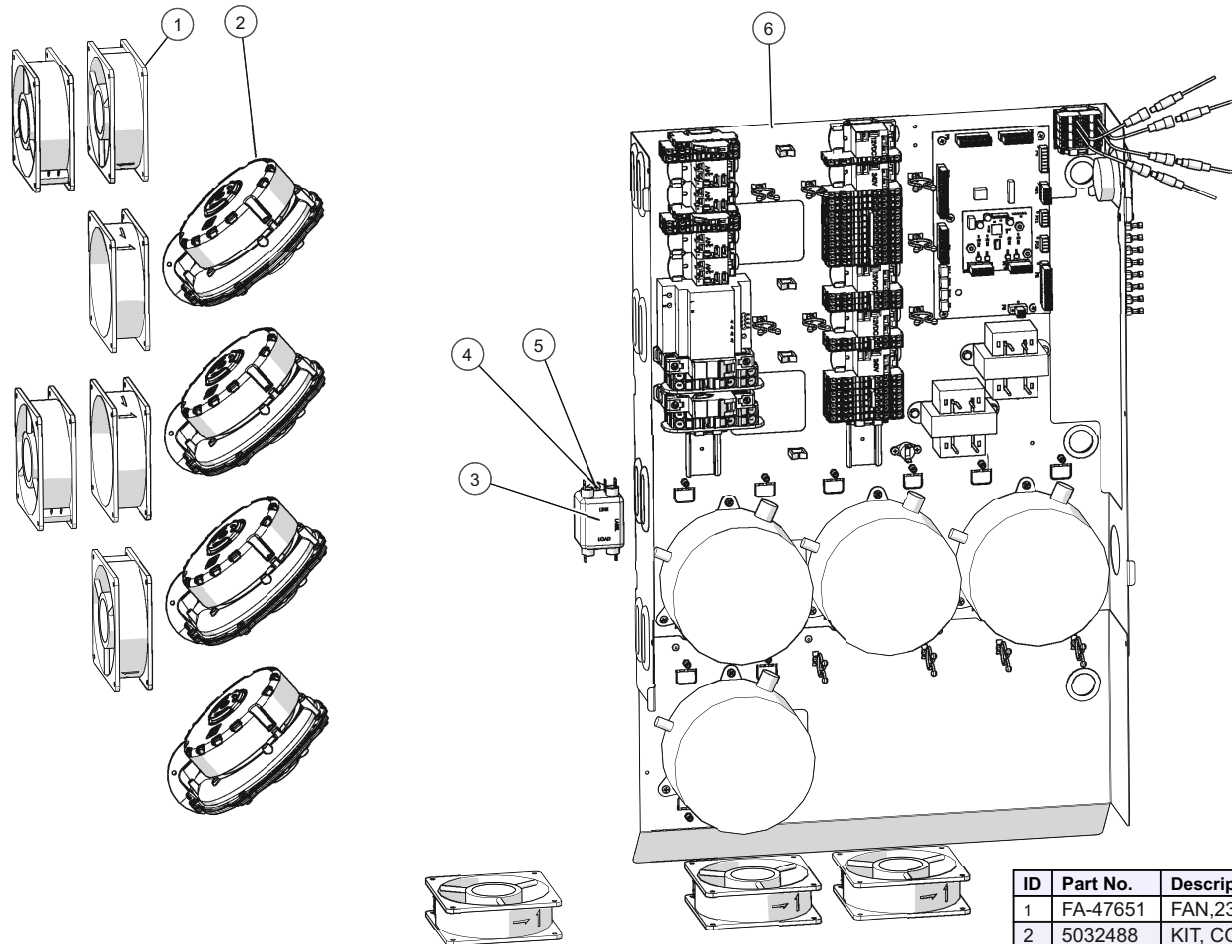

ID	Part No.	Description
1	FA-47651	FAN,230V,MECHATRONICS,HI-TEMP
2	5032488	KIT, COMBUSTION BLOWER 230V
3	FI-39629	FILTER, EMC, 10A, STD
4	NU-26866	NUT, HEX INSERT M4
5	SC-22273	SCREW,M4x0.7X10MM PAN
6	5029488	CHASSIS,ELEC ASSEM,F4 GAS 220V (see detail view)

Electrical Chassis, 220V—F4G

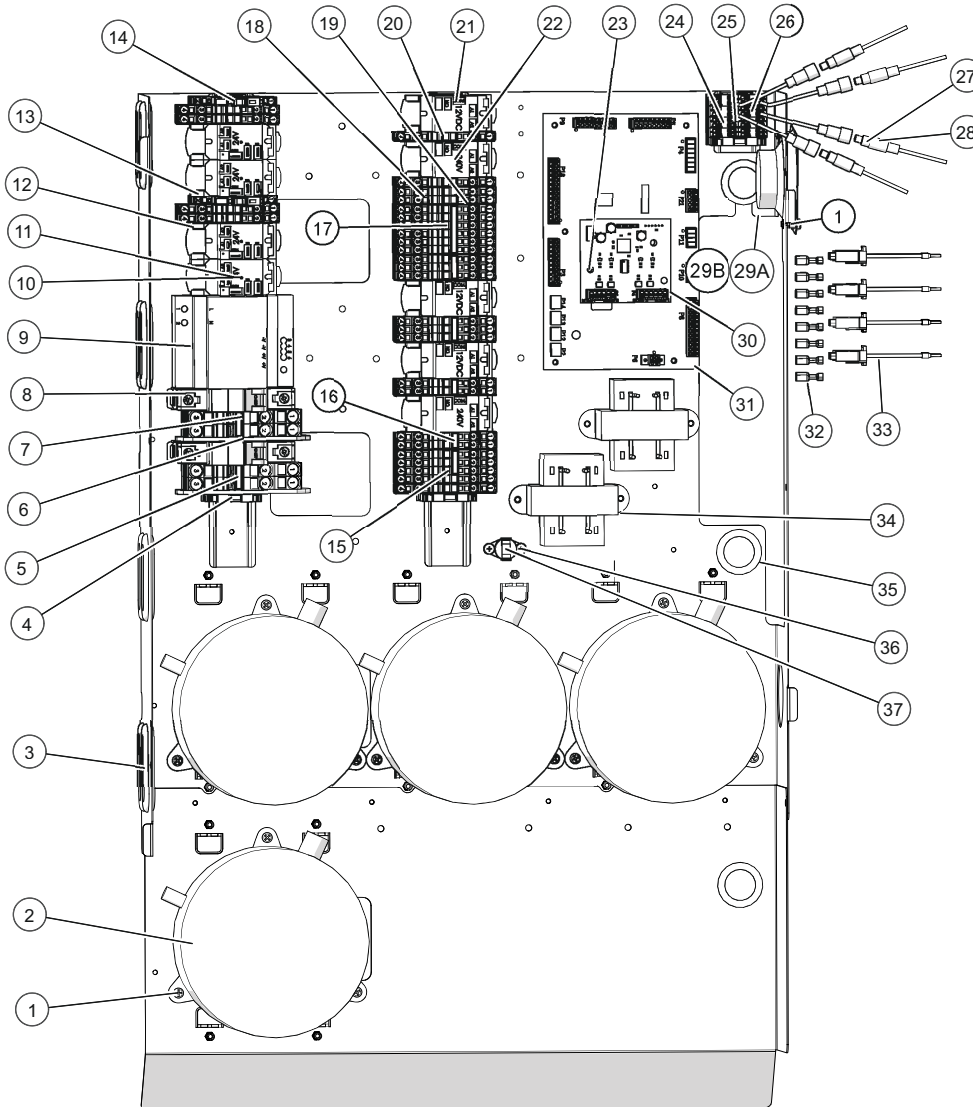

ID	Part No.	Description
1	SC-37702	SCREW, M4 X 12MM SEMS
2	BA-39727	BOARD CONTROLLER, TELCO
3	GS-46746	GROMMET, WIRE, 1-3/8"IDX2"OD
4	TM-39606	TERMINAL, SCREWLESS END
5	TM-37727	JUMPER BAR 2 POLE
6	TM-37726	TERMINAL, 10MM END
7	TM-37660	TERMINAL, 10mm, ORANGE, SPRING
8	FU-39058	CIRCUIT BREAKER, 20A
9	BA-46801	POWER SUPPLY, 12VDC, 100W
10	RL-39901	RELAY, 40AMP MIN POWER 24V
11	TM-37674	T BLOCK, RELAY MOUNT
12	TM-39574	TERMINAL, 6mm, ORANGE, SPRING
13	FU-33184	5X20MM, SLOW BLO, 2 AMP, 250V
14	TM-39577	TERMINAL, FUSE HOLDER,
15	TM-39584	JUMPER, 3 POLE
16	TM-39585	JUMPER, 2 POLE
17	TM-46073	JUMPER, 6 POLE
18	TM-39579	TERMINAL, GROUND, 6mm, SPRING
19	TM-39576	TERMINAL, END SECTION, SPRING
20	TM-39575	TERMINAL, 6mm, BLUE, SPRING
21	RE-37704	RELAY, 12VDC
22	RE-37725	RELAY, 240V AC
23	SC-46084	SCREW, NYLON 6-32 X 1/4"
24	TM-46689	TERMINAL, DIST BLOCK WHITE
25	TM-46668	TERMINAL, SUPPORT BRACKET
26	TM-46667	TERMINAL, DIST BLOCK BLACK
27	FU-46554	FUSE, 630mA, 250V, FAST ACTING,
28	FU-36762	IN-LINE FUSE HOLDER, 5X20MM 150 SERIES
29A	BZ-37655	SPEAKER, W/LEADS (Deluxe)
29B	BZ-39711	SPEAKER W/LEADS (Simple)
30	CC-46662	DAUGHTER BOARD, LVIO, PWM, SIT
31	CC-39528R	SERVICE KIT, CONTROL BOARD
32	CR-34639	CONNECTOR, QUICK DISCONNECT
33	5032252	CABLE, COMBUSTION POWER 3 PIN
34	TN-46388	TRANSFORMER, 240V-24V, 50VA
35	BU-37626	1-1/4" SNAP BUSHING
36	SC-38693	SCREW, #8-18 X 1/2", PHIL, PAN
37	TT-37680	THERMOSTAT, AUTO RESET,
39	5032287	CABLE, COOLING FAN HIGH LIMIT (not shown)
41	5032250	WIRE ASSEMBLY, FAN CONNECTOR (not shown)
42	5024271	WIRE PKG, COOLING FAN (not shown)
43	CB-47267	CABLE, BOARD TO BLOWER 46" (not shown)

Electrical Package, 220-240V—F4G

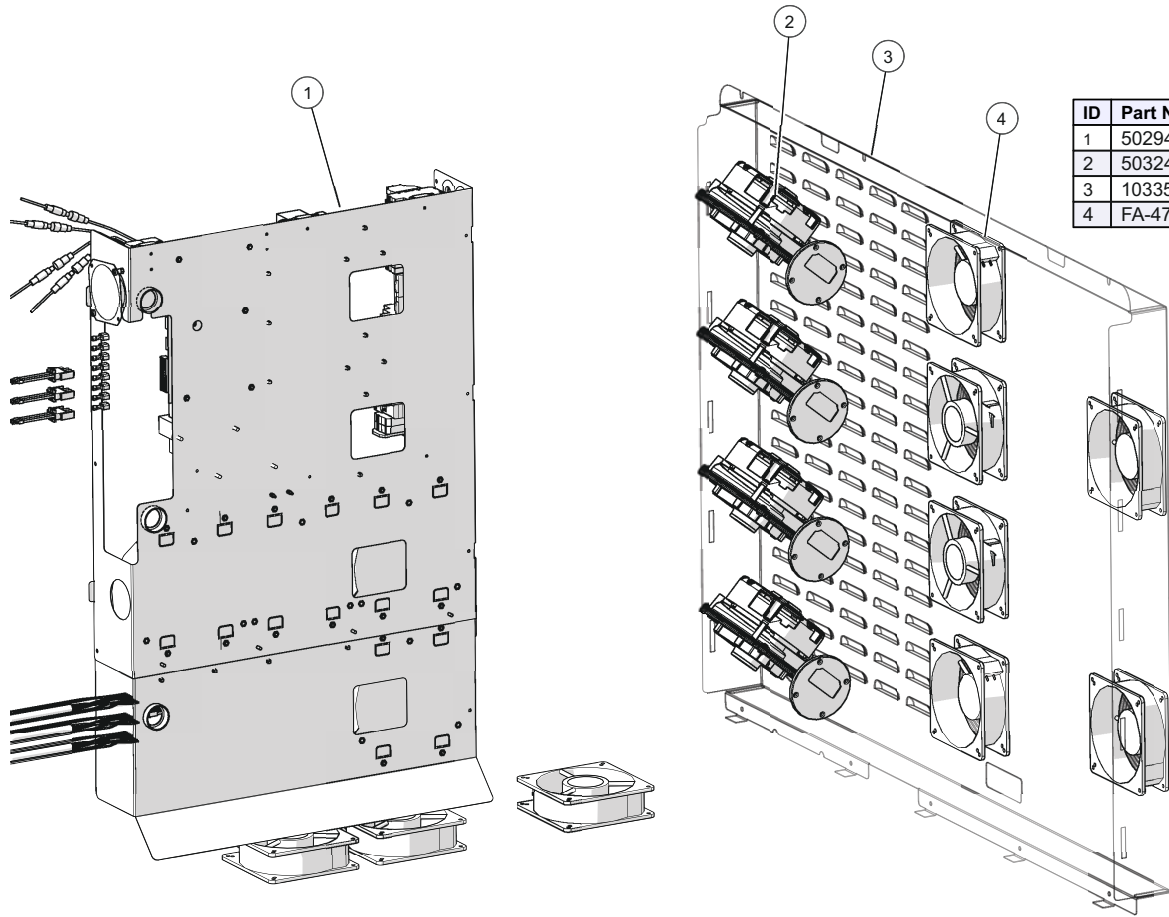

ID	Part No.	Description
1	5029475	CHASSIS,ELEC ASSEM,F4 GAS 240V (see detail view)
2	5032488	KIT, COMBUSTION BLOWER, 230V
3	1033512	PANEL, BACK CAV, F4 GAS
4	FA-47651	FAN,230V,50/60HZ

Electrical Chassis, 208-240V—F4G

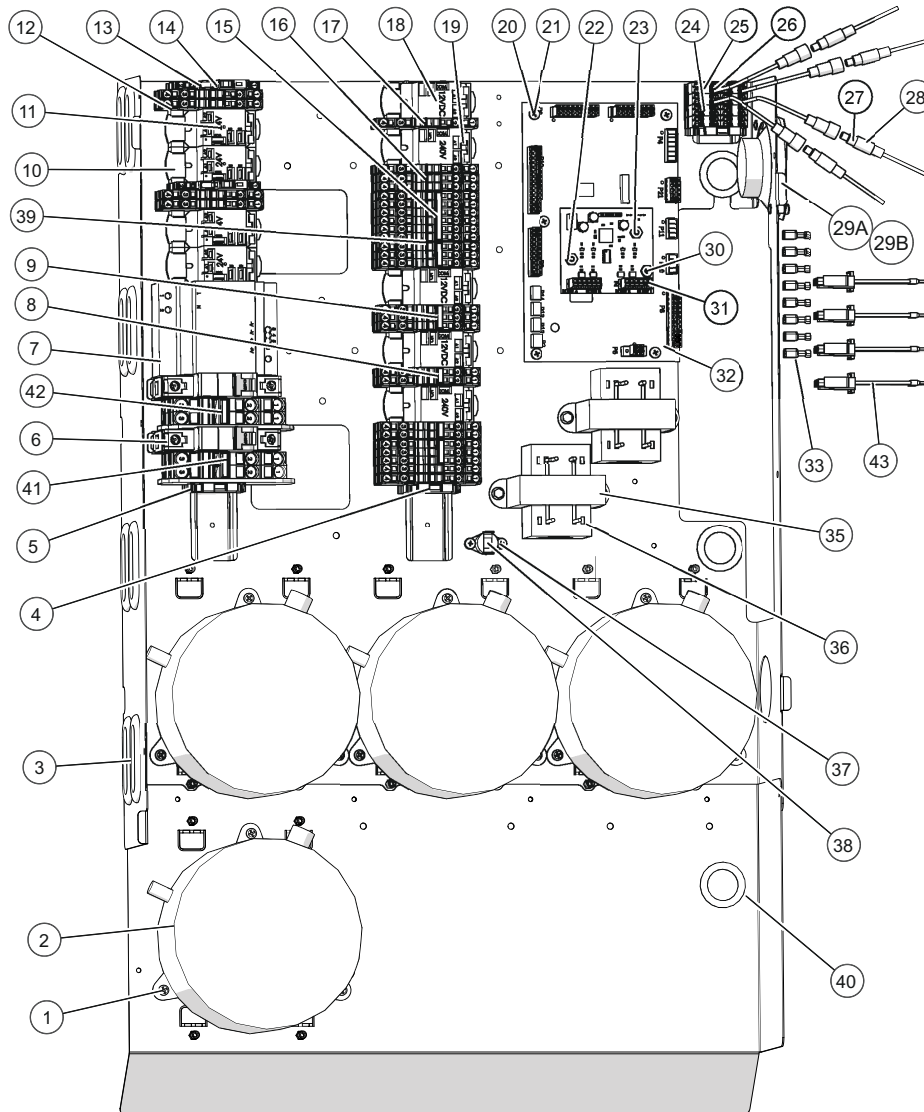

ID	Part No.	Description
1	SC-37702	SCREW, M4 X 12MM SEMS
2	BA-39727	BOARD CONTROLLER, TELCO
3	GS-46746	GROMMET, WIRE, 1-3/8"DX2"OD
4	TM-39606	TERMINAL, SCREWLESS END
5	TM-37726	TERMINAL, 10MM END
6	FU-39058	CIRCUIT BREAKER, 20A
7	BA-46801	POWER SUPPLY, 12VDC, 100W
8	TM-39585	JUMPER, 2 POLE
9	TM-39584	JUMPER, 3 POLE
10	TM-37674	T BLOCK, RELAY MOUNT
11	RL-39901	RELAY, 40AMP MIN POWER 24V
12	TM-39574	TERMINAL, 6mm, ORANGE, SPRING
13	FU-33184	5X20MM, SLOW BLO, 2 AMP, 250V
14	TM-39577	TERMINAL, FUSE HOLDER,
15	TM-46073	JUMPER, 6 POLE
16	TM-39579	TERMINAL, GROUND, 6mm, SPRING
17	TM-39575	TERMINAL, 6mm, BLUE, SPRING
18	RE-37704	RELAY, 12VDC
19	RE-37725	RELAY, 240V AC
20	SC-35729	SCREW, M4x0.7X8MM PAN
21	WS-22300	WASHER, M4 SPLIT LOCK
22	SC-46084	SCREW, NYLON 6-32 X 1/4"
23	ST-46083	SPACER, M/F HEX STANDOFF 6/32
24	TM-46689	TERMINAL, DIST BLOCK WHITE
25	TM-46667	TERMINAL, DIST BLOCK BLACK
26	TM-46668	TERMINAL, SUPPORT BRACKET
27	FU-46554	FUSE, 630mA, 250V, FAST ACTING,
28	FU-36762	IN-LINE FUSE HOLDER, 5X20MM 150 SERIES
29A	BZ-39711	SPEAKER W/LEADS, DELUXE
29B	BZ-37655	SPEAKER W/LEADS, SIMPLE
30	NU-39735	NUT, HEX, 6-32, NYLON
31	CC-46662	DAUGHTER BOARD, LVQ, PWM, SIT
32	CC-39528R	CONTROL BOARD SVC KIT
33	CR-34639	CONNECTOR, QUICK DISCONNECT
35	SC-39147	SCREW, 8-18 X .480 HEX WASHER
36	TN-46388	TRANSFORMER, 240V-24V, 50VA
37	SC-38693	SCREW, #8-18 X 1/2", PHIL, PAN
38	TT-37680	THERMOSTAT, AUTO RESET,
39	TM-39576	TERMINAL, END SECTION, SPRING
40	BU-37626	1-1/4" SNAP BUSHING
41	TM-37660	TERMINAL, 10mm, ORANGE, SPRING
42	TM-37727	JUMPER BAR 2 POLE
43	5032252	CABLE, COMBUSTION POWER 3 PIN
44	5032250	WIRE ASSEMBLY, FAN CONNECTOR (not shown)
45	5032287	CABLE, COOLING FAN HIGH LIMIT (not shown)

Chassis, Ignition Module—F4G

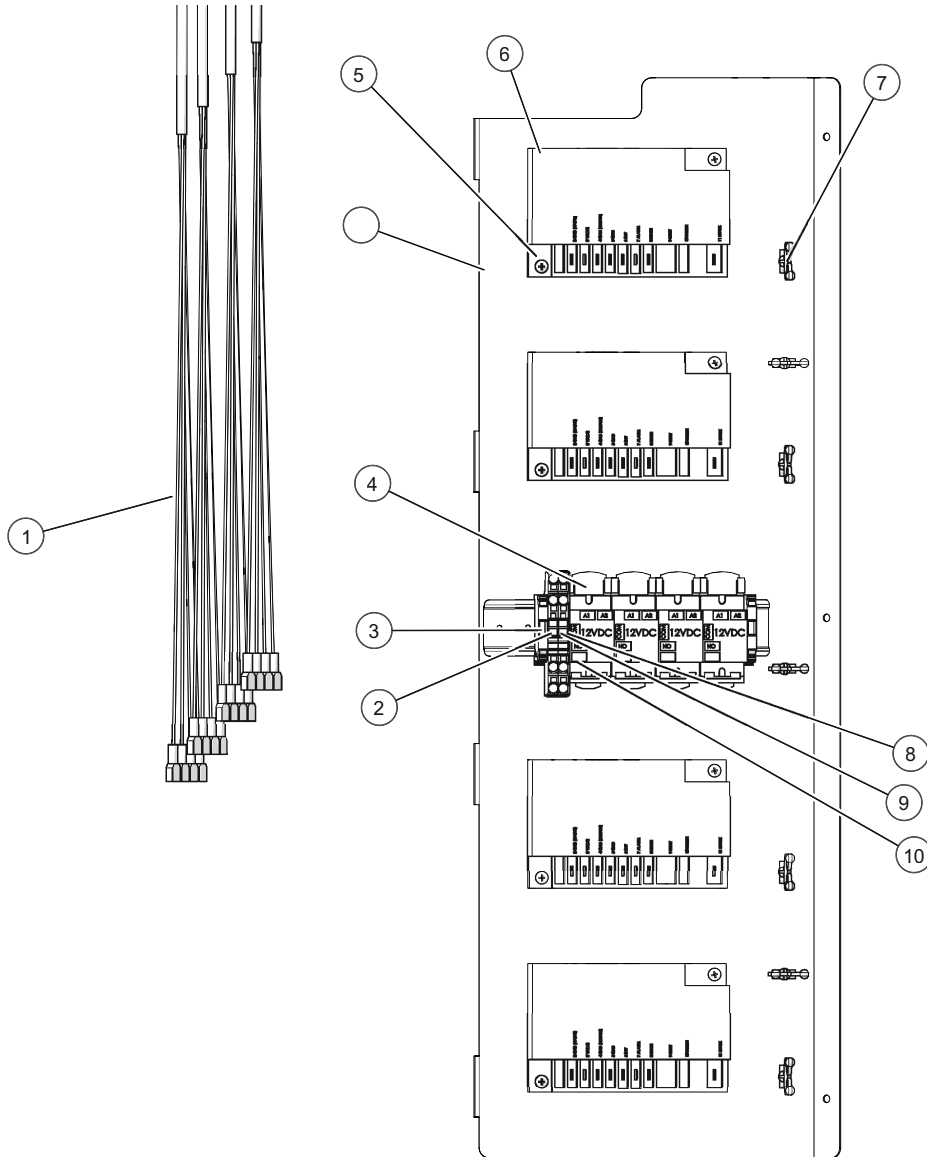

ID	Part No.	Description
1	CB-46078	CABLE, IGNITION MODULE 123"
2	TM-39579	TERMINAL,GROUND, 6mm, SPRING
3	TM-39606	TERMINAL, SCREWLESS END
4	TM-37674	T BLOCK, RELAY MOUNT
5	SC-22765	SCREW,M4x0.7X20MM PAN
6	BA-46469	BOARD, IGNITION CONTROL
7	TI-35719	TIE, TWIST LOCK 0.5" STANDOFF
8	TM-39576	TERMINAL, END SECTION, SPRING
9	TM-39579	TERMINAL,GROUND, 6mm, SPRING
10	RE-37704	RELAY, 12VDC
11	5032557	COMMON WIRE SET FOR F3G & F4G (not shown)
12	5032558	WIRE SET FOR F4G (not shown)

Control Board Service Kit (All Models)

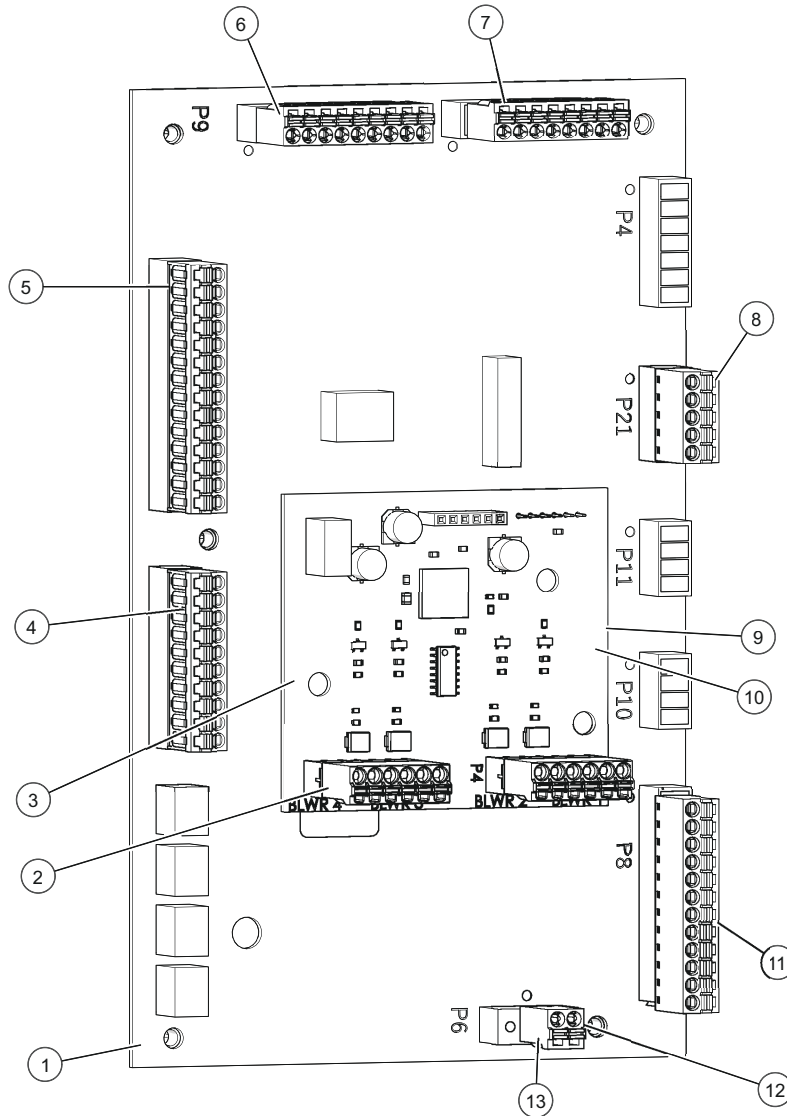

ID	Part No.	Description
1	CC-39528R	SERVICE KIT, CONTROL BOARD
2	TM-47279	TERMINAL, CONNECTOR, 6 PIN
3	SC-46084	SCREW,NYLON 6-32 X 1/4"
4	TM-37717	TERMINAL, CONNECTOR, 10 PIN
5	TM-37719	TERMINAL, CONNECTOR, 14 PIN
6	TM-37716	TERMINAL, CONNECTION, 9 PIN
7	TM-37715	TERMINAL, CONNECTION, 8 PIN
8	TM-37713	TERMINAL, CONNECTION, 5 PIN
9	CC-46662	DAUGHTER BOARD,LVIO, PWM, SIT
10	BA-46661	PCBA, PWM, SIT GAS BLOWER
11	TM-37718	TERMINAL, CONNECTOR, 12 PIN
12	NU-26866	NUT, HEX INSERT M4
13	TM-37711	TERMINAL, CONNECTION, 2 PIN
14	5032287	CABLE,COOLING FAN HIGH LIMIT (not shown)

Intake Flap Assemblies and Air Return (All Models)

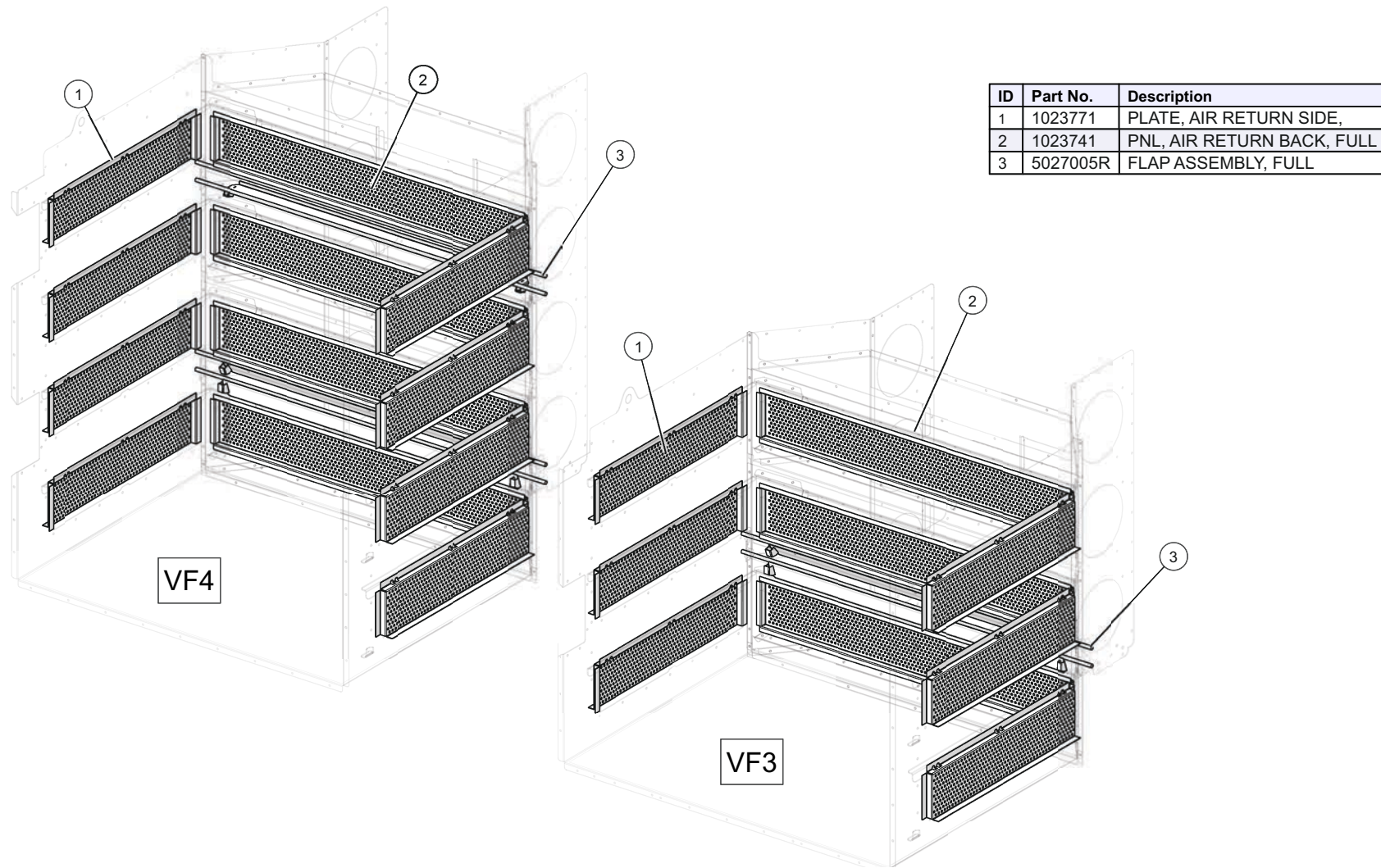

Probes (All Models)

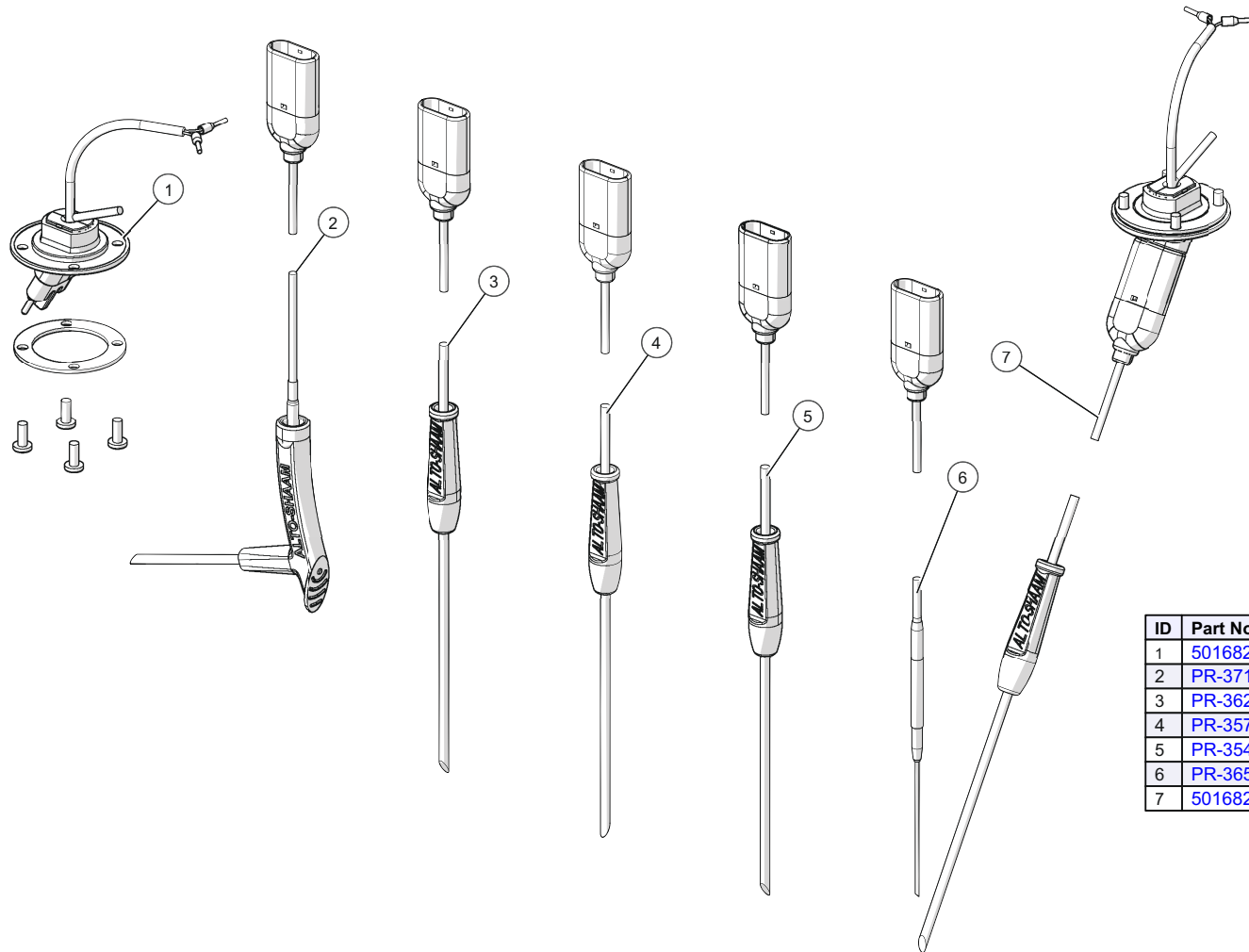

ID	Part No.	Description
1	5016820	SERVICE KIT, PROBE PKG
2	PR-37158	PROBE, QUICK RELEASE, 820mm
3	PR-36201	PROBE, QUICK RELEASE, 820mm
4	PR-35770	PROBE, QUICK RELEASE, 1000mm
5	PR-35487	PROBE, QUICK RELEASE, 1600mm
6	PR-36576	PROBE, SOUS VIDE, 1000MM
7	5016820R	SERVICE KIT, PROBE ,DETACHABLE

Mobile Base and Casters (All Models)

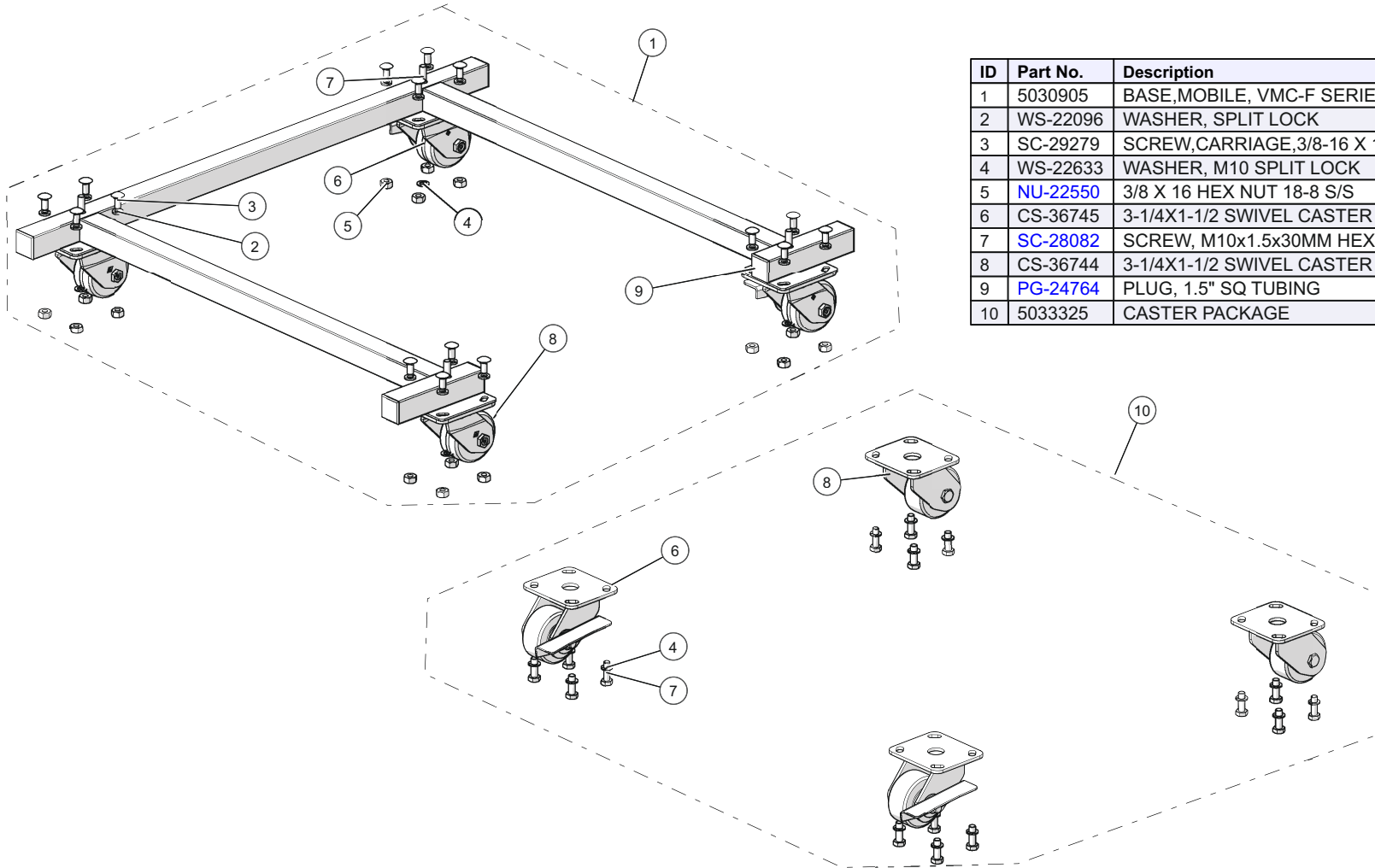

ID	Part No.	Description
1	5030905	BASE,MOBILE, VMC-F SERIES GAS
2	WS-22096	WASHER, SPLIT LOCK
3	SC-29279	SCREW,CARRIAGE,3/8-16 X 1,S/S
4	WS-22633	WASHER, M10 SPLIT LOCK
5	NU-22550	3/8 X 16 HEX NUT 18-8 S/S
6	CS-36745	3-1/4X1-1/2 SWIVEL CASTER W/BRAKE
7	SC-28082	SCREW, M10x1.5x30MM HEX
8	CS-36744	3-1/4X1-1/2 SWIVEL CASTER
9	PG-24764	PLUG, 1.5" SQ TUBING
10	5033325	CASTER PACKAGE



ALTO-SHAAM.

Menomonee Falls, WI U.S.A.

Phone 800-558-8744 | +1-26 2-251-3800 | alto-shaam.com

ASIA

Shanghai, China
Phone +86-21-6173-0336

AUSTRALIA

Brisbane, Queensland
Phone 800-558-8744

CANADA

Concord, Ontario Canada
Toll Free Phone 866-577-4484
Phone +1-905-660-6781

FRANCE

Aix en Provence, France
Phone +33(0)4-88-78-21-73

GMBH

Bochum, Germany
Phone +49 (0)234 298798-0

ITALY

Padua, Italy
Phone +39 3476073504

INDIA

Pune, India
Phone +91 9657516999

MEXICO

Phone +52 1 477-717-3108

MIDDLE EAST & AFRICA

Dubai, UAE
Phone +971-4-321-9712

CENTRAL & SOUTH AMERICA

Miami, FL USA
Phone +1 954-655-5727

RUSSIA

Moscow, Russia
Phone +7 903 7932331