

This Base Manual covers all
Commercial Combination/Convection
Microwave Ovens with 230/208 V, 60 Hz.
Refer to individual Technical Sheet
for information on specific models.

ACE208
ACE230

Service

Commercial Combination/ Convection Microwave Oven with 230/208 V, 60 Hz

Service Manual for
Amana®

This manual is to be used by qualified appliance technicians only. Amana does not assume any responsibility for property damage or personal injury for improper service procedures done by an unqualified person.

Amana®

RS2220002
Revision 0
November 2000

Important Product Information



WARNING

Precautions to be observed before and during servicing to avoid possible exposure to excessive microwave energy, or electrical shock disconnect power to oven.

Do not operate or allow oven to be operated with door open.

Make the following safety checks on all ovens to be serviced before activating the magnetron or other microwave source, and make repairs as necessary:

- Interlock operation
- Proper door closing
- Seal and sealing surfaces (arcing, wear, and other damage)
- Damage to or loosening of hinges and latches
- Evidence of dropping or abuse

Before turning on microwave power for any service test or inspection within the microwave generating compartments, check the magnetron, waveguide or transmission line, and cavity for proper alignment, integrity, and connections.

Any defective or misadjusted components in the interlock, monitor, door seal, and microwave generation and transmission systems shall be repaired, replaced or adjusted by procedures described in this manual before oven is released to the consumer.

Check microwave leakage to verify compliance with the federal performance standard should be performed on each oven prior to release to the consumer.

WIRING

Good service practice is to never route wiring over terminals and/or sharp edges. This applies to any wiring without regard to the circuit voltage. Wire insulation material and thickness is designed and regulated for electrical spacing purpose only, but cannot always be relied upon because of possible cuts and/or abrasions, which can occur during servicing.



WARNING

To avoid risk of electrical shock, injury, or death, make sure these grounding instructions are followed.

Grounding Instructions



WARNING

Do not remove grounding prong when installing grounded appliance in a home or business that does not have three wire grounding receptacle, under no condition is grounding prong to be cut off or removed. It is the personal responsibility of the consumer to contact a qualified electrician and have properly grounded three prong wall receptacle installed in accordance with appropriate electrical codes

Should a two prong adapter plug be required temporarily it is the personal responsibility of the consumer to have it replaced with properly grounded three prong receptacle or the two prong adapter properly grounded by a qualified electrician in accordance with appropriate electrical codes.

Servicing of Grounded Products

The standard accepted color coding for grounding wires is GREEN or GREEN WITH YELLOW STRIPE. These ground leads are NOT to be used as current carrying conductors. It is extremely important that the technician replace any and all grounds prior to completion of the service call. Under no condition should ground wire be left off causing a potential hazard to technicians and consumer.

Table of Contents

Important Product Information	2	Component Testing Procedures	19
Important Information	4	Test Modes	
Important Safety Information	5	Microwave Power Test	23
Product Information		Temperature Chart	23
Strirrer Blade	7	Convection Temperature Test	24
Blower/Fan Assembly	7	Convection Temperature Calibration	24
Stirrer Cover	7	Radiation Leakage Testing	25
Door Interlock and Monitoring Switch	7	Equipment	25
Transformer High Voltage	7	Procedure For Measuring Radiation Leakage	25
High Voltage Capacitor	7	Measurement With the Outer Panel Removed	25
High Voltage Diode (Rectifier)	7	Measurement With a Fully Assembled Oven	25
Magnetron	7	Record Keeping and	
Thermal Protectors	7	Notification After Measurement	25
Touch Panels	7	Display Diagnostics	
Triacs	7	Error Codes	26
RTD (Resistive Thermal Device)	7	Service Test	27
Heating Elements	7	Troubleshooting	
Installation		Power up	29
Grounding Instructions	8	Preheat/Convection Condition	29
Unpacking Oven	8	Microwave Condition	30
Radio Interference	8	Disassembly	
Oven Placement	8	Door Handle	31
Care and Cleaning		Outer Door	31
Recommended Maintenance Schedule	9	Inner Door Assembly	31
Recommended Cleaning Schedule	9	Hinge	31
Cleaning Oven Exterior	9	Outer Case	32
Cleaning Oven Cavity	9	Back Panel	32
Oven Racks and Rack Guides	9	Stirrer Cover	32
Air Filter	9	RTD (Resistance Thermal Device)	32
Discharge Air Vents	9	Top Touch Panel Assembly	32
Display and Features	10	Side Touch Panel Assembly	33
Programming		High Voltage Circuit Board	33
Programming Pads	13	Interlock Switch Module	33
Programming Multiple Stages	13	Adjustment	33
Programming Preheat Setting	13	Display Module	34
Convection Cooking		Magnetron	34
Convection Cooking with Programmed Pads	14	Magnetron, Control, and	
Convection Cooking Using Manual Time Entry	14	Fan Thermal Cutout (TCO)	34
Combination Cooking(microwave and convection)		Triacs	34
Combination Cooking with Preprogrammed Pads	15	Microwave Blower Wheel and Motor	34
Using Maunal Time Entry	15	Fan Blade	35
Combination Cooking	15	Transformer	35
User Options	16	Capacitor	35
User Maintenance		Heater Box	35
Replacing Oven Light	17	Heating Elements	35
Moving Oven Rack Guides	17	Convection Fan and Motor	35
Service Codes	17	Fuse	35
Specifications	18	Power Cord	36
		Light Socket	36
		Replacing Oven Light Bulb	36
		Component Location	37

Important Information

Pride and workmanship go into every product to provide our customers with quality products. It is possible, however, that during its lifetime a product may require service. Products should be serviced only by a qualified service technician who is familiar with the safety procedures required in the repair and who is equipped with the proper tools, parts, testing instruments and the appropriate service manual. **REVIEW ALL SERVICE INFORMATION IN THE APPROPRIATE SERVICE MANUAL BEFORE BEGINNING REPAIRS.**

Important Notices for Consumers and Servicers

WARNING

To avoid risk of serious injury or death, repairs should not be attempted by an unauthorized person, dangerous conditions (such as exposure to electrical shock) may result.

CAUTION

Amana will not be responsible for any injury or property damage from improper service procedures. If performing service on your own product, assume responsibility for any personal injury or property damage which may result.

To locate an authorized servicer, please consult your telephone book or the dealer from whom you purchased this product. For further assistance, please contact:

CONSUMER AFFAIRS DEPT.
AMANA REFRIGERATION, INC.
AMANA, IOWA 52204

**OR
CALL**

1-319-622-5511
and ask for
Consumer Affairs

If outside the United States contact:

AMANA
ATTN: CONSUMER AFFAIRS DEPT
AMANA, IOWA 52204, USA
Telephone: (319) 622-5511
Facsimile: (319) 622-2180
TELEX: 4330076 AMANA
CABLE: "AMANA", AMANA, IOWA, USA

Recognize Safety Symbols, Words, and Labels

DANGER

DANGER - Immediate hazards which **WILL** result in severe personal injury or death.

WARNING

WARNING - Hazards or unsafe practices which **COULD** result in severe personal injury or death.

CAUTION

CAUTION - Hazards or unsafe practices which **COULD** result in minor personal injury or product or property damage.

Important Safety Information



CAUTION

Do not become exposed to radiation from the microwave generator or other parts conducting microwave energy.

Basic design of this microwave oven makes it an inherently safe device to both use and service. However, there are some precautions which should be followed when servicing microwave oven to maintain this safety. These are as follows:

1. Always operate unit from an adequately grounded outlet. Do not operate on a two-wire extension cord.
2. Before servicing unit (if unit is operable) perform microwave leakage test.
3. Oven should never be operated if door does not fit properly against seal, hinge/hinge bearings are damaged or broken; choke is damaged, (pieces missing, etc.); or any other visible damage can be noted. Check choke area to ensure that this area is clean and free of all foreign matter. If any above problems occur take the following steps:
 - Tell the user not to operate the oven.
 - Contact Amana immediately.
4. If oven operates with door open and produces microwave energy, take the following steps:
 - Tell the user not to operate the oven.
 - Contact Amana immediately.
5. Always have oven disconnected when outer case is removed except when making "live" tests called for in the service manual. Do not reach into equipment area while unit is energized. Make all connections for the test and check them for tightness before plugging cord into outlet.
6. Always ground capacitors on magnetron filter box and H.V. capacitor with an insulated-handle screwdriver before working in high voltage area of equipment compartment. Some types of failures will leave a charge in capacitors and the discharge could cause a reflex action which could make you injure yourself.
7. In the area of the transformer, capacitor, diode, and magnetron there is HIGH VOLTAGE. When unit is operating, keep area clean and free of anything which could possibly cause an arc or ground, etc.
8. **DO NOT** for any reason defeat interlock switches, there is no valid reason for this action at any time; nor will it be condoned by Amana.
9. Microwave oven should never be operated with:
 - Any components removed and/or bypassed
 - Any of the safety interlocks are found to be defective
 - Any of the seal surfaces are defective, missing, or damaged
10. To ensure that unit does not emit excessive microwave leakage and to meet Department of Health and Human Services guidelines check oven for microwave leakage using Narda Model 8100, 8200, Holaday HI1500, HI1501, or Simpson 380M leakage monitor as outlined in instructions. Maximum leakage level allowed is 4mw/cm².
11. If servicer encounters an emission reading over 4mw/cm², servicer is to cease repair and contact Amana Service Department immediately for further direction. Amana will contact the proper Government Agency upon verification of test results.
12. Install or locate this equipment **ONLY** in accordance with the installation instructions in this manual.
13. Some products such as whole eggs and sealed containers – for example, closed glass jars – may explode and **SHOULD NOT** be **HEATED** in this equipment.
14. Use this equipment **ONLY** for its intended use as described in this manual. Do not use corrosive chemicals or vapors in this equipment. This type of equipment is specifically designed to heat or cook. It is not designed for industrial or laboratory use.
15. As with any equipment, **CLOSE SUPERVISION** is necessary when used by **CHILDREN**.
16. **DO NOT** operate this equipment if it has a damaged cord or plug, if it is not working properly, or if it has been damaged or dropped.
17. This equipment, including power cord, must be serviced **ONLY** by qualified service personnel. Special tools are required to service equipment. Contact nearest authorized service facility for examination, repair, or adjustment.
18. **DO NOT** cover or block any openings on the equipment.
19. **DO NOT** store this equipment outdoors. **DO NOT** use this product near water – for example, near a kitchen sink, in a wet basement, or near a swimming pool, and the like.
20. **DO NOT** immerse cord or plug in water.
21. Keep cord **AWAY** from **HEATED** surfaces.
22. **DO NOT** let cord hang over edge of table or counter.

Important Safety Information

CAUTION

To avoid risk of personal injury or death of fire in the oven cavity:

- **DO NOT** overcook food. Carefully attend equipment if paper, plastic, or other combustible materials are placed inside the equipment to facilitate cooking.
- Remove wire twist-ties from paper or plastic bags before placing bag in equipment.
- **KEEP equipment DOOR CLOSED**, turn equipment off, and disconnect the power cord, or shut off power at the fuse or circuit breaker panel, if materials inside the equipment should ignite. Fire may spread if door is opened.
- **DO NOT** use the cavity for storage purposes. **DO NOT** leave paper products, cooking utensils, or food in the cavity when not in use.

CAUTION

To avoid personal injury or property damage, observe the following:

1. Briskly stir or pour liquids before heating with microwave energy to prevent spontaneous boiling or eruption. Do not overheat. If air is not mixed into a liquid, liquid can erupt in equipment or after removal from equipment.
2. Do not deep fat fry in equipment. Fat could overheat and be hazardous to handle.
3. Do not cook or reheat eggs in shell or with an unbroken yolk using microwave energy. Pressure may build up and erupt. Pierce yolk with fork or knife before cooking.
4. Pierce skin of potatoes, tomatoes, and similar foods before cooking with microwave energy. When skin is pierced, steam escapes evenly.
5. Pop popcorn in microwave mode only. If equipment is preheated or hot, allow equipment to cool before popping popcorn or bag may ignite.
7. Do not use regular cooking thermometers in equipment when cooking in microwave or combination mode. Most cooking thermometers contain mercury and may cause an electrical arc, malfunction, or damage to equipment.
8. Do not heat baby bottles in equipment.
9. Do not use metal utensils in equipment except when recommended by microwave food manufacturers or recipe requires metal utensils in convection or combination mode. Heat food in containers made of glass or china if possible.
10. Never use paper, plastic, or other combustible materials that are not intended for cooking. If equipment temperature is high, material may ignite.
12. Do not use paper towels which contain nylon or other synthetic fibers. Heated synthetics could melt and cause paper to ignite.
13. Do not heat sealed containers or plastic bags in equipment. Food or liquid could expand quickly and cause container or bag to break. Pierce or open container or bag before heating.
14. Racks, utensils, and equipment surfaces may become hot during or after use. Use utensils or protective clothing, like pan grips or dry oven mitts, when necessary to avoid burns.
15. Do not use rack position if rack hook breaks. Replace broken hooks immediately.
16. Do not unplug equipment immediately after use. Internal fan must cool equipment to avoid damage of electrical components.

Product Information

Stirrer Blade

Distributes microwave energy throughout the cavity.

Blower/Fan Assembly

Circulates cooling air throughout the convection or microwave oven compartment and cavity.

Stirrer Cover

Covers and protects the stirrer blade assembly.

Door Interlock and Monitoring Switch

NOTE: When the line fuse is blown the Interlock Switch Assembly must be replaced.

Interlock switch (assembly) mounts behind oven cavity front bulkhead. It is actuated by door hook and guide attached to the door.

Monitoring switch (contacts 7 and 8) is actuated by the door guide.

The secondary interlock switch (contacts 2 and 3) and primary interlock switch (contacts 4 and 5) are actuated by the door hook.

The secondary interlock switch is in series with the interlock monitoring switch in the monitor circuit.

If a malfunction occurs in the secondary interlock when door opens, current will flow through the monitor switch causing the oven fuse to open.

If a faulty door interlock switch has allowed current through the monitor switch, the switch assembly must be replaced (see interlock switch testing) before replacing fuse.



DANGER

To avoid severe personal injury or death avoid contacting any high voltage parts. The capacitors are at high voltage (4000 volt) potential and it is extremely important that they be grounded before handling.

Transformer High Voltage

High voltage transformer is used in this unit, which supplies high voltage A.C. for operation of the magnetron tube.

High Voltage Capacitor

Doubles the A.C. output voltage from the high voltage transformer.

High Voltage Diode (Rectifier)

Is connected at the output side of the high voltage capacitor. It changes voltage from A.C. to D.C. It passes current in one direction and blocks it in the other. Also called a rectifier.

Magnetron

With filament voltage and high D.C. voltage from the output of the H.V. capacitor, diode junction the magnetron will put out an electromagnetic radio frequency of 2450 MHz to heat the food load in the oven.

Thermal Protectors

At a predetermined temperature the thermal cut-outs will open or close. The oven will indicate an error code in the display, initiate cooling fan operation, or prevent the generation of microwave energy.

- Magnetron thermal cut-out is mounted directly on the body of the magnetron
- Fan thermal cut-out is mounted directly on the exhaust duct
- Control thermal cut-out is mounted directly on the heater box

Touch Panels

Allows consumer operation and programming of oven.

Triacs

Triacs are controlled by high voltage circuit boards. Triacs control one side of the power line going to the high voltage power transformer and heating elements.

- Microwave triacs, heating elements A, and B triacs are mounted inside oven chassis behind oven cavity front bulkhead

RTD (Resistance Thermal Device)

Senses temperature inside oven cavity.

Heating Elements

Heating elements are used to produce convection heat.

Installation

Grounding Instructions

NOTE: Do not under any circumstances cut or remove grounding prong from the plug or bend power prongs to fit receptacle other than one shown for your equipment. Such abuse of the plug can result in electrical shock or overheating.

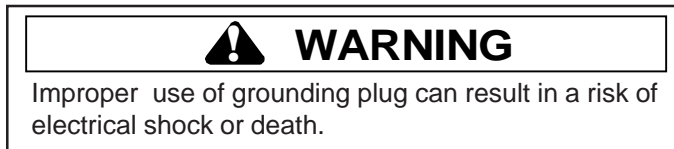

This equipment **MUST** be grounded. In the event of an electrical short circuit, grounding reduces risk of electric shock by providing an escape wire for electric current. This oven is equipped with a cord having grounding wire with a grounding plug. Plug must be plugged into an outlet that is properly installed and grounded. **DO NOT** use a two-prong adapter.

Consult a qualified electrician or servicer if grounding instructions are not completely understood, or if doubt exists as to whether the equipment is properly grounded.

Do not use an extension cord. If product power cord is too short, have a qualified electrician install an appropriate receptacle. This equipment should be plugged into a separate 60 Hz circuit with the appropriate electrical rating label. Models **ACE208** require a 208 voltage supply and model **ACE230** requires a 230/240 voltage supply. When the combination oven is on a circuit with other equipment, an increase in cooking times may be required and fuses can be blown.

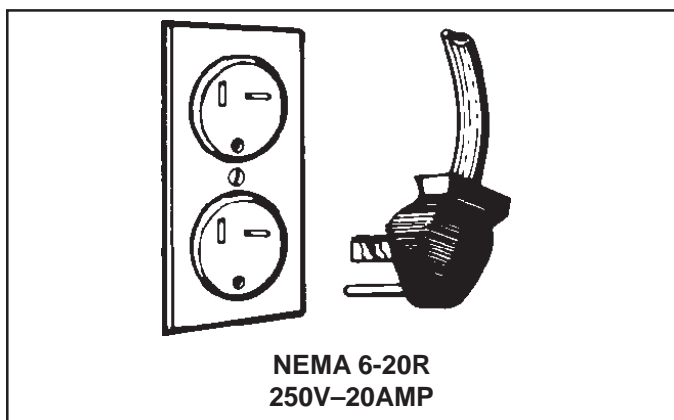

Unpacking Oven

- Inspect oven for damage such as dents in door or inside oven cavity.
- Report any dents or breakage to source of purchase immediately.
- **Do not attempt to use oven if damaged.**
- Remove all materials from oven interior.
- If oven has been stored in extremely cold area, wait a few hours before connecting power.

Radio Interference

Microwave operation may cause interference to radio, television, or a similar oven. Reduce or eliminate interference by doing the following:

- Clean door and sealing surfaces of oven according to instructions in *Care and Cleaning* section.
- Place radio, television, etc. as far as possible from oven.
- Use a properly installed antenna on radio, television, etc. to obtain stronger signal reception.

Oven Placement

- Do not install oven next to or above source of heat, such as pizza oven or deep fat fryer. This could cause microwave oven to operate improperly and could shorten life of electrical parts.
- Do not block or obstruct oven filter. Allow access for cleaning.
- Install oven on level countertop surface.
- Place warning label in a conspicuous place close to microwave oven.
- Outlet should be located so that plug is accessible when oven is in place.

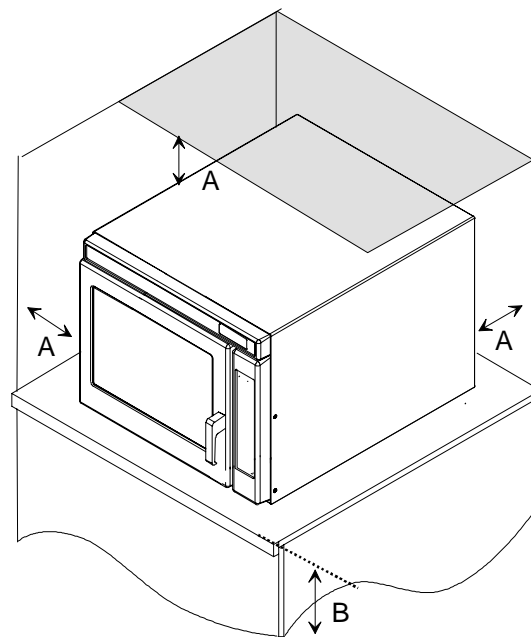

- A—Allow at least 1 1/4" (3.18 cm) of clearance around top and sides of oven. Proper air flow around oven cools electrical components. With restricted air flow, oven may not operate properly and life of electrical parts is reduced.
- B—Install combination oven so oven bottom is at least 3 feet (91.5 cm) above floor.

Care and Cleaning

Clean oven frequently to maximize oven life, performance, and efficiency. A dirty oven cooks inefficiently because moisture, spills, and grease absorb convection and microwave energy.



WARNING

To avoid electrical shock which can cause severe personal injury or death, disconnect power to appliance before cleaning.



CAUTION

To prevent personal injury, handle utensils, racks, and door with care. Utensils, racks, and door may become hot during operation.

Recommended Maintenance Schedule

Schedule Maintenance Cleaning (**Not Covered Under Warranty**)

- Contact an authorized servicer to remove and clean heater box.
- Schedule appointment every 12 months or when heavy grease buildup is apparent on back of oven cavity.

Recommended Cleaning Schedule

Schedule **Several Daily Cleanings**

- Clean interior, exterior, door, and racks according to instructions.
- If possible, clean spills immediately.
- Clean air filter and air vents regularly to prevent overheating.
- Wipe dry after cleaning.

Clean After Use

- Remove oven racks and rack guides, and clean according to Oven Racks and Rack Guides instructions.
- Clean exterior according to Cleaning Oven Exterior instructions.
- Clean oven cavity according to Cleaning Oven Cavity instructions.
- Wipe dry after cleaning.

Cleaning Oven Exterior

Clean door and other exterior surfaces with a clean cloth, sponge, or nylon pad using a mild detergent diluted in warm water. Use commercial degreasers if heavily soiled.

- If spraying solutions into oven cavity, protect interior rear wall from moisture or mist.

- Do not use harsh or abrasive cleaners, or cleaners containing ammonia.
- Do not use water pressure type cleaning systems.
- Remove excess water from cloth before wiping oven.

Cleaning Oven Cavity

Remove racks and rack guides for best results. Recommended cleaning solution is **Convection Express Cleaner**. Repeat cleaning several times if necessary. Saturate oven interior surfaces with Amana Convection Express Cleaner and let sit for 2 to 5 minutes. Rub vigorously with nylon scouring pad to loosen debris. Wipe clean with warm, damp clean cloth.

NOTE: A plastic putty knife or equivalent may be used to remove baked on debris.

- Wear protective rubber gloves when cleaning oven.
- Use only a plastic putty knife, nylon scouring pad or equivalent, to aid in removing soil or build-up from the oven interior.
- **Do not use** knife, **metal** utensil, or **steel wool pad** to remove baked on material. This will damage the teflon coating.
- Refer to warranty for limitations regarding teflon interior and cleaning requirements.

Oven Racks and Rack Guides

Clean the oven racks and rack guides with a detergent solution made with warm water. Scrub with a soft nylon pad to loosen and remove any baked on materials. **DO NOT use a lye based oven cleaner, such as many of the 'instant' oven cleaners.** This will damage the finish of the oven, the racks, and rack guides.

Air Filter

Air filter must be cleaned regularly to prevent overheating of oven. The air filter is located directly below the oven door.

1. Remove the filter retaining screws, located on the outside edges of the filter.
2. Remove the air filter.
3. Wash filter in a mild detergent solution made with warm water.
4. Rinse and dry thoroughly.
5. Replace filter and screws.

NOTE: Clean air filter regularly to prevent overheating, which may damage oven.

Discharge Air Vents

Check for a buildup of cooking vapors along discharge louvers in back of oven. Clean air vent with damp cloth to ensure proper airflow. Dry thoroughly.

Display and Features

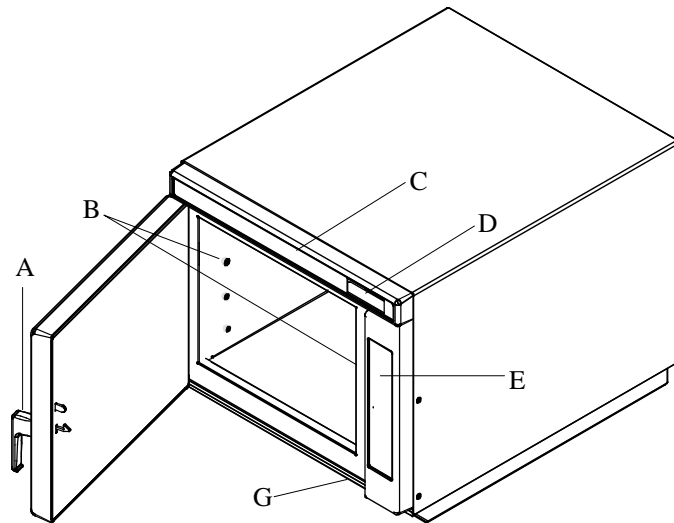

A—Oven Door Handle (Lift to open.)
 B—Rack Guides
 C—Top Control Panel

D—Display
 E—Side Control Panel
 G—Air Intake Filter

Oven Features

Item flashes in display indicating keypads can be used and cooking entries can be made.

Temperature is displayed in the time field.

Display



Preheat not ready indicates the oven is not at preheat temperature. NOT flashes while the oven heats to preheat temperature.

Display and Features (cont'd)

Item is not displayed indicating keypad will not accept entries. To activate keypad, open and close oven door—Item will then display.



Preheat ready displays when oven has reached the preset preheat temperature.

Displays stage the oven is cooking in during multi-stage cooking cycles.

Displays menu number selected by user.

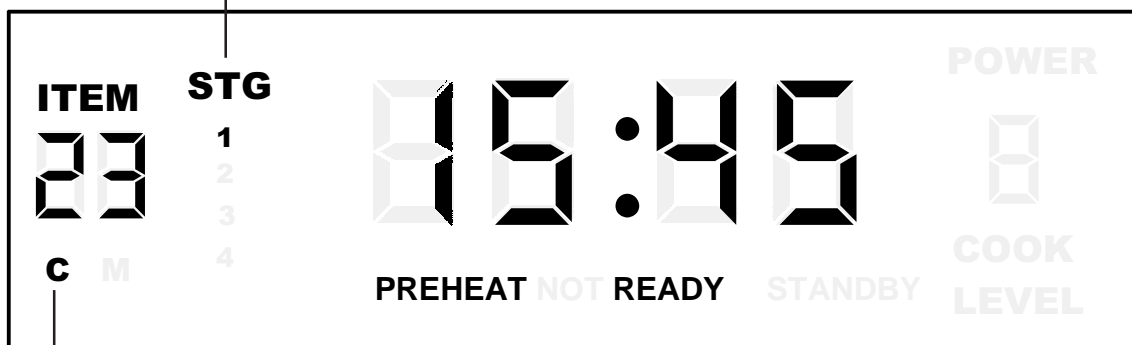

Convection cooking only.

Power displays when oven is actively generating microwave energy. Will not display when set at 0, and will turn on and off when set less than HI.

Time left in cooking condition



Indicates percentage of microwave power (0 to 100%). 9 is 90%, 5 is 50%, H is High (100%).

Combination cooking: both convection (C) and microwave energy (M) are used.

Cook level displays with the amount of microwave energy used.

Display and Features (cont'd)

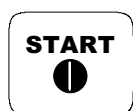
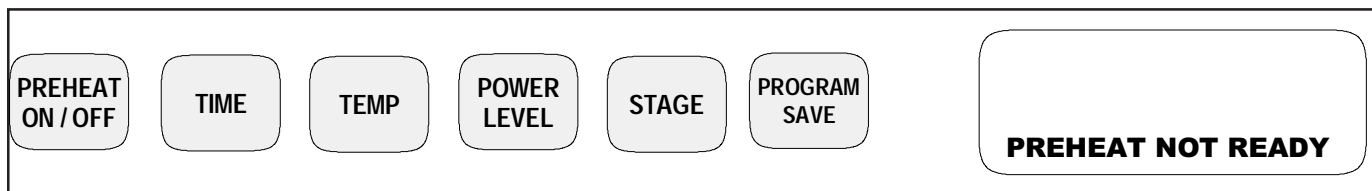

Start Pad

The start pad is used to begin a manual time entry cooking cycle.



STOP/RESET pad

The STOP/RESET pad stops a cooking sequence in progress, clears out any remaining time, and also ends a programming or user option cycle. When the STOP/RESET pad is used to end a programming or option change, the changes are discarded.

Temperature warnings

The combination oven has two distinct temperature warnings:

- A warning when the preheat temperature does not match the preprogrammed temperature of a cooking condition.
- A warning when the actual oven cavity temperature is not to preheat temperature, such as when the oven is first started.

Cooking Display

DISPLAYS	DESCRIPTION
PREHEAT READY	PREHEAT READY displays when oven has reached preheat temperature and is ready to cook.
00:00	Displays cooking time. If stage cooking is programmed, total cooking time is displayed.
PREHEAT NOT READY	PREHEAT NOT READY displays and NOT flashes when oven is turned on and is warming up to the selected preheat temperature.
COOK LEVEL	COOK LEVEL displays the current microwave power level. HI is the highest setting, and 0 is lowest (no microwave energy used).
ITEM	ITEM displays the single or double digit entry of a programmed cooking condition when using a programmed pad. ITEM also flashes when a cooking condition can be started or programmed.
STG	STG displays with a single number. This is the stage the oven is at in the cooking condition.
STANDBY	STANDBY displays when oven is turned off, and also after the oven is plugged in, the door is opened, and then shut.
C M	C M displays when oven is convection cooking.
C M	C M displays when oven is cooking using both microwave energy and convection.
POWER	POWER displays during active microwave generation in the oven. POWER will not display when power setting is at 0; and POWER will turn on and off when microwave energy is set at less than HI.

Programming Display

DISPLAYS	DESCRIPTION
PROG	Displays when oven is in programming mode for single pad or double pad memory.
OP: --	Displays when oven is in user option mode. User options can then be set or specified.
STG	Displays stage number during cooking or when programming a specific cooking stage. Stage number (1 through 4) indicates the stage that is being used.

Programming

Programming Pads

Oven is shipped from the factory for single pad programming. To change the oven default to double pad programming, see *User Option* section. To program the amount of time, power level, or temperature setting for a pad.

1. Oven must be ON.
 - Press PREHEAT ON/OFF.
 - ITEM must flash in display.
2. Press PROGRAM SAVE.
 - Programming mode begins.
 - PROG displays.
 - Oven is in programming mode.
3. Press pad to be programmed or reprogrammed.
 - Display will change to review all settings for the pad.
 - The pad number that is being programmed displays below the word ITEM.
4. Press TIME to program amount of cooking time.
 - Enter desired cooking time by using numeric key pads.
5. Press TEMP pad to program the cooking temperature.
 - Enter desired convection temperature by using numeric pads.
6. Press POWER LEVEL to program level of microwave power.
 - Press POWER LEVEL again to set to H (High).
 - For a lower microwave power, press pads 1 (for 10%) through 9 (for 90%). **0 turns off the microwave power and cooking is by convection only.**
7. Press PROGRAM SAVE to save the program changes.
8. To discard changes, press STOP/RESET.

PREHEAT
ON / OFF

PROGRAM
SAVE

TIME

TEMP

POWER
LEVEL

PROGRAM
SAVE

Programming Preheat Setting

The convection temperature setting can be set between 150°F to 475°F. It is recommended to set the preheat setting to the most commonly used temperature for that oven. The factory default preheat setting is 450°F.

To program the preheat setting:

1. Press PREHEAT ON/OFF pad.
2. Press PROGRAM SAVE pad.
3. Press TEMP pad.
4. Enter desired temperature by using the numeric key pads.
5. Preheat temperature is changed.

STAGE

What is stage cooking?

Stage cooking enables several different cooking cycles, or stages, to be used consecutively without repeated input from the user. Stage cooking can be set to defrost food initially, then cook it, and then keep the food warm until serving time.

Programming Multiple Stages

Stage cooking allows consecutive cooking cycles without interruption. Up to four different cooking cycles can be programmed into a memory pad.

To use stage cooking:

1. Follow steps 1 through 6 above.
7. Press STAGE.
 - This will begin programming for the next cooking stage.
 - Display indicates stage to be programmed.
 - Enter cook time, temp and power level as in steps 4, 5 and 6.
 - To enter another cooking stage for that pad, press STAGE pad again.
 - Up to four different stages can be programmed.
8. Press PROGRAM SAVE to save the program and changes.
9. To discard changes, press STOP/RESET before pressing PROGRAM SAVE.

STAGE

PROGRAM
SAVE

Example of Stage Cooking Conditions

	Stage 1	Stage 2	Stage 3
Temp	450°F	450°F	450°F
Power	H (high)	3	0
Time	2:30	1:30	1:30

Convection Cooking



CAUTION

To avoid risk of burns, handle utensils, racks, and door with care. Allow oven, utensils, and racks to cool before cleaning. Oven, utensils, and racks, become hot during operation.

Convection Cooking

Convection cooking utilizes both a convection element and fan to evenly distribute heated air throughout the oven cavity. By circulating air, no hot or cold spots occur, creating a consistent temperature envelope around the food. These consistent temperatures cook food evenly and reduces cooking time. Oven will always operate in convection mode.



All the pad does is beep.

Ovens are not shipped preprogrammed. Any preset cooking conditions must be set by the customer. If a pad is pressed that has not been programmed, a rapid triple beep will sound and no cooking condition will initiate.

To operate the oven for convection cooking only, you can use preprogrammed pads or manual time entry. **The following instructions are for convection cooking only.** For combination cooking, see that section.

Convection Cooking with Programmed Pads

1. Press PREHEAT ON/OFF to start the oven.
 - Oven begins a preheat cycle.
 - PREHEAT NOT READY displays.
 - To change preheat settings, see *Programming*.
2. Oven reaches preheat temperature.
 - Signal sounds and PREHEAT READY displays.
3. Press selected pad.
 - ITEM must be flashing in display. If not, open and close door.
 - If using single pad programming, press pad and oven begins automatically.
 - For double pad programming, press pads in proper sequence and oven begins automatically.
4. Cooking cycle begins
 - Total cooking time is displayed.
 - To display the temperature while a program is running, press the TEMP button and the temperature will briefly display.
5. Oven finishes cooking sequence
 - An end of cycle beep signals the end of the cooking cycle.
 - **Oven interior and cooking dish will be hot.**
6. Press PREHEAT ON/OFF to shut off oven.

PREHEAT
ON / OFF

Convection Cooking Using Manual Time Entry

1. Press PREHEAT ON/OFF to start the oven.
 - Oven begins a preheat cycle.
 - PREHEAT NOT READY displays.
 - To change preheat settings, see *Programming*.
2. Oven reaches preheat temperature.
 - Signal sounds and **PREHEAT READY** displays.
3. Press TIME.
 - Enter desired cooking time by using the keypad.
4. Press TEMP if cooking temperature is different than preheat temperature.
 - Enter the new temperature.
5. Press POWER LEVEL.
 - **For convection cooking only, press 0.**
6. To activate stage cooking, press STAGE and repeat steps 3, 4, and 5.
 - Up to 4 different stages can be programmed.
7. Press the START pad to begin the cooking cycle.

PREHEAT
ON / OFF

TIME

TEMP

POWER
LEVEL

START
●

Combination Cooking (microwave and convection)



CAUTION

To avoid risk of burns, handle utensils, racks, and door with care. Allow oven, utensils, and racks to cool before cleaning. Oven, utensils, and racks, become hot during operation.

To operate the oven for combination cooking, you can use preprogrammed pads or manual time entry. **The following instructions are for combination cooking only.** For convection only cooking, see that section.

Combination Cooking with Preprogrammed Pads

1. Press PREHEAT ON/OFF to start the oven.
 - Oven begins a preheat condition.
 - PREHEAT NOT READY displays with NOT flashing.
 - To change preheat temperature, see *Programming* section.
2. Oven reaches preheat temperature.
 - Signal sounds and PREHEAT READY displays.
3. Press desired pad.
 - For double pad programming, press pads in proper sequence.
 - Oven begins automatically.
4. Cooking cycle begins
 - Total cooking time is displayed.
 - To display the temperature while a program is running, press the TEMP button and the temperature will briefly display.
5. Oven finishes cooking sequence
 - An end of cycle beep signals the end of the cooking cycle.

Oven interior and cooking dish will be hot.
6. Press PREHEAT ON/OFF to shut off oven.

PREHEAT
ON / OFF

Combination Cooking

The combination mode uses both the speed of **microwave energy** and browning of **convection** cooking to yield fast, high quality food.

- Microwave cooking uses high frequency energy waves to heat the food. When cooking, microwave energy causes food molecules to move rapidly. This rapid movement between the food molecules creates heat, which cooks the food. POWER displays when oven is generating microwave energy for the current cycle.
- Convection cooking uses the selected oven temperature to bake and brown foods. The circulating air surrounds food in an envelope of evenly heated air.
- Oven will maintain a minimum convection temperature of 150°F (66°C) to ensure drier air and more even cooking.

Using Manual Time Entry

1. Press PREHEAT ON/OFF to start the oven.
 - Oven begins a preheat condition.
 - PREHEAT NOT READY displays with NOT flashing.
 - To change the preheat temperature, see *Programming*.
2. Oven reaches preheat temperature.
 - Signal sounds and PREHEAT READY displays.
3. Press TIME.
 - Enter desired cooking time by using numeric keypad.
4. Press TEMP if cooking temperature differs from preheat temperature.
 - Enter the new temperature.
5. Press POWER LEVEL.
 - To have microwave power on HIGH, press the POWER LEVEL pad again. H displays.
 - For a lower microwave power, press pads 1 (for 10%) through 9 (for 90%). 0 turns off the microwave power and cooking is by convection only.
6. If stage cooking is desired, press STAGE and repeat steps 3, 4, and 5.
 - Up to 4 different stages can be programmed.
7. Press the START pad to begin the cooking cycle.

PREHEAT
ON / OFF

TIME

TEMP

POWER
LEVEL

START
●

User Options



**HIDDEN
PAD**

PREHEAT
ON / OFF

TIME

Didn't like an option?

Factory settings are marked in bold. To change the oven back to the factory setting, simply select the option that is marked in bold.

My changes weren't saved.

In order for any changes to be saved, the PROGRAM SAVE pad must be pressed after selecting an option. Pressing the STOP/RESET pad will not save changes.

Changing user options

Options such as single or double pad programming, beep volume, and maximum cooking time can be changed to suit individual preferences.

To change options, oven must display **STANDBY**.

1. Press hidden pad.
 - Pad is unmarked and located to the direct left of PREHEAT ON/OFF pad.
 - Nothing will be displayed when hidden pad is pressed.
2. Press PROGRAM SAVE pad.
 - OP: displays. Oven is now in options mode.
3. Press number pad that controls option to be changed.
 - See table below for options.
 - Current option will display.
4. Press number pad again to change the option.
 - Each time pad is pressed, option will change.
 - Match code displayed with code for desired option.
5. Press PROGRAM SAVE pad to save changes.
 - To change additional options, repeat steps 3 and 4.
 - Changes take affect after PROGRAM SAVE pad is pressed.
6. Press STOP/RESET to return to STANDBY, or open and close oven door.

Numbered Pads	Display	Options (Factory Settings in Bold)
1 Preprogrammed Pads	OP:10	Allows 10 (0-9) preprogrammed pads.
	OP:11	Allows 100 (00-99) preprogrammed pads.
2 Manual Time Entry	OP:20	Manual time entry/cooking not allowed
	OP:21	Manual time entry/cooking allowed
3 Reset to READY mode	OP:30	Opening oven door does not reset oven back to ready mode
	OP:31	Opening oven door resets the oven back to ready mode
4 Keybeep	OP:40	Keys do not beep when pressed (keybeep off)
	OP:41	Keys beep when pressed (keybeep on)
5 Keybeep Volume	OP:50	Keybeep volume OFF
	OP:51	Keybeep volume low
	OP:52	Keybeep volume medium
	OP:53	Keybeep volume high
6 Food Done Signal	OP:60	Food done signal is a continuous beep until reset by user
	OP:61	Food done signal is a three second beep
	OP:62	Food done signal is four beeps, one time only
	OP:63	Food done signal is four beeps, four times
7 Keypad Time Entry	OP:70	Keypad time entry window is 15 seconds
	OP:71	Keypad time entry window is 30 seconds
	OP:72	Keypad time entry window is one minute
	OP:73	Keypad time entry window is two minutes
8 Temperature Warnings	OP:80	Both temperature warnings off
	OP:81	Warning only when preheat temperature does not match preprogrammed temperature
	OP:82	Warning only when actual oven cavity temperature is not to preheat temperature
	OP:83	Both temperature warnings on
TEMP PAD Temperature Scale	OP:bo	°F
	OP:b1	°C

User Maintenance

Replacing Oven Light

1. Disconnect electrical supply.
2. Remove screw from access cover on top left wall of oven exterior.
3. While wearing protective gloves, unscrew the light bulb counterclockwise.
4. Replace light bulb with 230-volt (rated 250V), 40-watt appliance bulb.
 - **Do not over tighten bulb or it may be difficult to remove later.**
5. Replace light bulb cover and access cover before use.
6. Reconnect power supply.

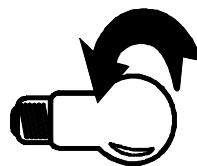

WARNING

To avoid risk of burns or electrical shock:

- disconnect electrical supply to oven before changing light bulb.
- before replacing light bulb make sure oven and bulb are cool.
- do not operate oven without bulb and access cover in place.

Moving Oven Rack Guides

The oven rack guides can be moved to one of three positions within the oven, allowing for versatility in cooking and placement of food. The middle rack position is the most common. Guides can also be removed for easier cleaning.

To remove rack guides:

1. Oven cavity must be cool to touch.
2. Remove oven rack by lifting up and sliding to the front of the oven.
3. Apply gentle pressure by pulling upwards on the front of rack guide.
4. Lift the rear of the rack guide to remove. Guide may be snug.



CAUTION

Wear gloves to protect hands from accidental bulb breakage.

To replace rack guides:

1. Oven cavity must be cool to touch.
 - UP on guide rack should be in correct direction for placement.
2. Place rear of rack guide over desired anchor in back of oven and push down.
3. Place front of rack guide over desired anchor in front of oven.
 - Apply firm pressure to front and rear of rack guide to fit onto anchor.
 - Fit may be tight.
 - Rack guide should not move after being set in place.
4. Replace oven rack as desired.
 - Slide oven rack towards rear of oven, holding upwards to avoid detents.
 - Oven rack can be placed upwards or downwards. Upwards is recommended.
 - Oven rack must be seated in detents.



Service codes

During operation, the oven may display one of the following codes. **If this should occur:**

1. Unplug oven and leave unplugged for approximately one minute. Plug oven in and see if code reappears.
 - If code does not reappear, continue normal use with the oven.
2. If service code reappears, write down the service code displayed and contact the nearest authorized Amana Servicer.
 - Do not use oven until contacting the Amana Servicer.

Error Codes

ERR1

ERR2

ERR3

ERR4

ERR5

ERR6

ERR7

Specifications

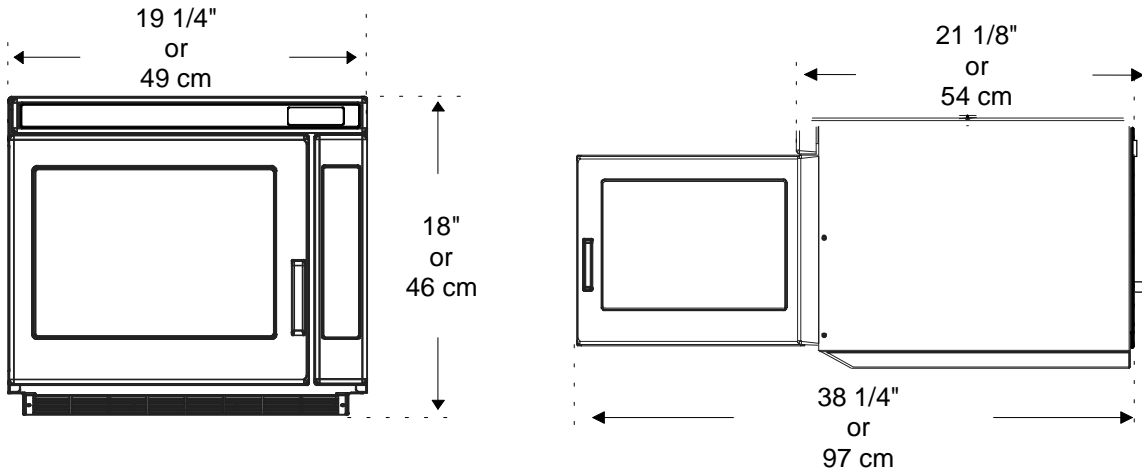

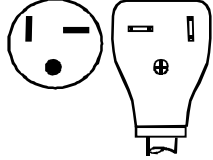
MODEL	ACE*** (** indicates model number)	
Power Source	ACE208	ACE230
Voltage AC	208 VAC	230 VAC
Frequency	60 Hz	
Amperage	20 A	
Power		
Frequency	2450 MHz	
Nominal Microwave Energy (IEC705)	1000 Watts	
Power Consumption	Combination: 3300 watts Convection only: 2700 watts	
Power Cord Length	5' 6" (168 cm)	
Oven Cavity Dimensions inches (cm)	13" (33 cm) x 10½" (27 cm) x 15" (38 cm)	
Net Weight	112lbs. (51 kg)	
Oven Cavity Capacity	1.2 Cu. Ft. (34 L)	
Receptacle and plug	NEMA 6-20R	



Product specifications can change at any time without notice.

Component Testing Procedures



WARNING

To avoid risk of electrical shock, personal injury, or death, disconnect power to oven and discharge capacitor before servicing, unless testing requires it.

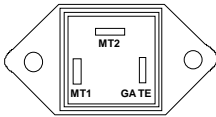
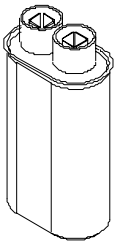
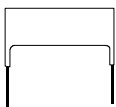
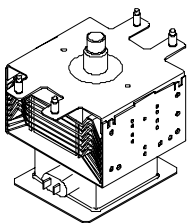
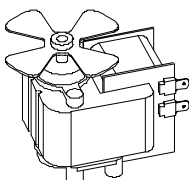
Illustration	Component	Test	Results
	Thermal cutout	Disconnect all wires from TCO. Measure resistance across terminals. Control TCO..... Fan TCO..... Magnetron TCO.....	Open at 300°F (149°C) and closed at 257°F (125°C) Closed at 160°F (71°C) and open at 125°F (52°C) Open at 235°F (113°C) and closed at 150°F (66°C)
	Diode	Discharge Capacitor Remove diode lead from capacitor and connect ohmmeter. Reverse leads for second test.	Infinite resistance should be measured in one direction and 50KΩ or more in the opposite direction. NOTE: Ohmmeter must contain a battery of 6 volts minimum.
	Triac	Disconnect wires to triac. Measure resistance from: MT1 to MT2 MT1 to Gate..... MT2 to Gate..... All terminals to ground	Caution - Do not operate oven with wire to terminal MT2 removed. Infinite Approximately 15 Ω, then reverse meter leads 30 Ω Infinite Infinite
Triac 1 (top) is for front element Triac 2 (middle) is for rear element Triac 3 (bottom) is for microwave		Measure voltage from: MT1 to Gate	0.8 VAC when energized If no voltage, check H.V. board and wiring.
	Capacitor	Discharge Capacitor Remove wires from capacitor terminals and connect ohmmeter, set on highest resistance scale to terminals. Also check between each terminal and capacitor case.	Between Terminals: Meter should momentarily deflect towards zero then return to over 5 MΩ. IF no deflection occurs, or if continuous deflection occurs, replace capacitor. Terminal to Case: Infinite resistance
	Snubber assembly	Disconnect wires to snubber. Measure resistance across terminals.	Infinite
	Magnetron	Discharge Capacitor Remove wires from magnetron and connect ohmmeter to terminals. Also check between each terminal and ground.	Between Terminals: Less than 1 Ω Each terminal to ground measures Infinite resistance. Note: This test is not conclusive. If oven does not heat and all other components test good replace the magnetron and retest.
	Microwave blower motor	Remove all wires from motor. Measure resistance across coil.	Approximately 33 Ω

Component Testing Procedures



WARNING

To avoid risk of electrical shock, personal injury, or death, disconnect power to oven and discharge capacitor before servicing, unless testing requires it.

Illustration	Component	Test	Results
	Transformer	<p>Discharge Capacitor Remove all wires from terminals.</p> <p>Measure resistance from: 230 to COM 208 to COM 230 to Ground 208 to Ground Terminal 5 to 6 Terminal 4 to Ground</p>	<p>Less than 1 Ω Less than 1 Ω Infinite Infinite Less than 1 Ω Approximately 70 Ω</p>
<p>Door Closed</p> <p>2 —•— 3 Secondary 4 —•— 5 Primary 7 —•— 8 Monitor</p>	Interlock switch	<p>Disconnect wires to switch.</p> <p>With door open measure resistance from: Terminal 2 to 3 Terminal 4 to 5 Terminal 7 to 8</p> <p>With door closed measure resistance from: Terminal 2 to 3 Terminal 4 to 5 Terminal 7 to 8</p>	<p>Infinite Infinite Indicates continuity</p> <p>Indicates continuity Indicates continuity Infinite</p>
	Convection blower motor	<p>Remove wires from motor.</p> <p>Measure resistance across terminals A and B.</p>	Approximately 20 Ω
	Heating element assembly	<p>Disconnect wires from terminals.</p> <p>Measure resistance across heating element.</p> <p>Front element 1200 W</p> <p>Rear element 1500 W</p>	<p>Indicates continuity</p> <p>ACE208 ACE230 35 Ω 43 Ω</p> <p>29 Ω 35 Ω</p>
	Resistance thermal device (RTD)	<p>Temperature</p> <p>32°F</p> <p>350°F</p>	<p>Resistance</p> <p>1000 Ω</p> <p>1654 Ω</p>
	Lamp receptacle	Test continuity of receptacle terminals.	Indicates continuity with bulb screwed in.

Component Testing Procedures

⚠ WARNING

To avoid risk of electrical shock, personal injury, or death, disconnect power to oven and discharge capacitor before servicing, unless testing requires it.

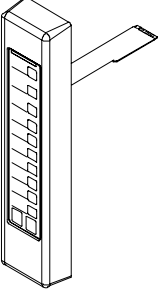
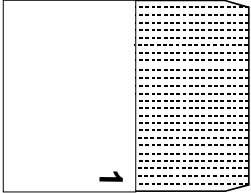
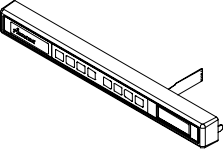
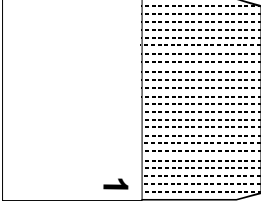
Illustration	Component	Test	Results		
	Side touch panel	Continuity is indicated as 100 Ω and below. 	Pad 1 2 3 4 5 6 7 8 9 0 Start Stop/Reset	Trace 3 & 5 3 & 6 3 & 7 3 & 8 3 & 9 4 & 5 4 & 6 4 & 7 4 & 8 4 & 9 5 & 6 6 & 9	Measurement Continuity Continuity Continuity Continuity Continuity Continuity Continuity Continuity Continuity Continuity Continuity Continuity
	Top touch panel	Continuity is indicated as 100 Ω and below. 	Pad Preheat Time Temp Power Level Stage Program Save Hidden Pad	Trace 3 & 4 5 & 7 7 & 8 5 & 8 5 & 9 6 & 7 8 & 9	Measurement Continuity Continuity Continuity Continuity Continuity Continuity Continuity
Wire harness	High voltage board to display module harness	Test continuity of wires.	Indicates continuity		

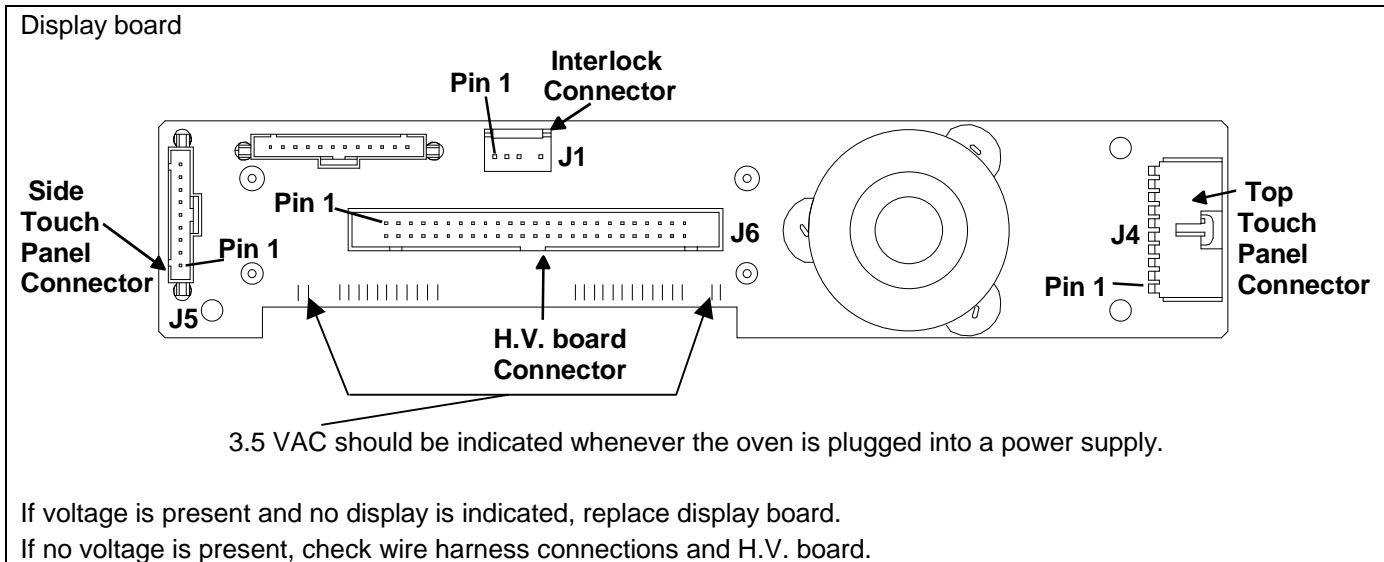

Component Testing Procedures



WARNING

To avoid risk of electrical shock, personal injury, or death, disconnect power to oven and discharge capacitor before servicing, unless testing requires it.

H.V. board

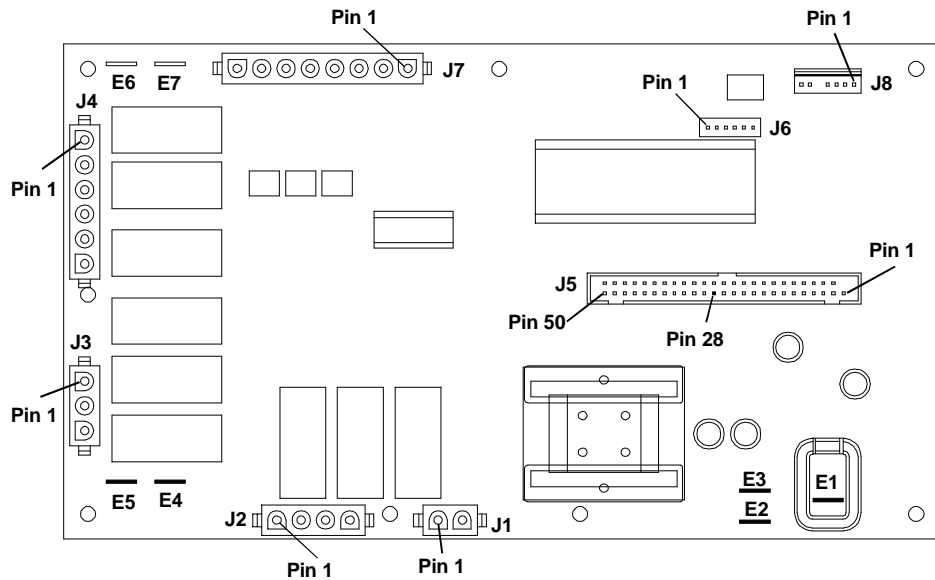

In straight convection mode, both elements operate simultaneously.

In combination mode, the rear element will operate simultaneously with either the microwave or front element.

Function	Test Set-Up	Meter Setting	Probe Placement	Results
Input to H.V. board	At H.V. board	Volts	J1 pin 1 (Black wire) & J1 pin 2 (Red wire)	Line voltage
Output to display board	Disconnect J5 connector	Volts	J5 pin 28 & J5 pin 50	- 24 VDC

NOTE: For the following test, place oven in Service Test Mode (see page 27).

Relay	Function	Test Set-Up	Meter Setting	Probe Placement	Results
K1	Cooling fan	Disconnect J2 connector	Ohms	J1 pin 1 (Black wire) & J2 pin 4	Test mode 5 off - no continuity Test mode 5 on - < 1 Ω
K2	Convection motor	Disconnect J2 connector	Ohms	J1 pin 1 (Black wire) & J2 pin 3	Test mode 4 off - no continuity Test mode 4 on - < 1 Ω
K3	Cavity light	Disconnect J2 connector	Ohms	J2 pin 1 & J2 pin 2	Test mode 6 off - no continuity Test mode 6 on - < 1 Ω
K4	Heater A (front)	Disconnect J3 connector	Ohms	E4 & J3 pin 3	Test mode 2 off - no continuity Test mode 2 on - < 1 Ω
K7	Microwave	Disconnect J4 connector	Ohms	J4 pin 4 & J4 pin 5	Test mode 3 off - no continuity Test mode 3 on - < 1 Ω
K9	Heater B (rear)	Disconnect J4 connector	Ohms	E6 & J4 pin 1	Test mode 1 off - no continuity Test mode 1 on - < 1 Ω

Test Modes

Microwave Power Test

(TRADITIONAL TEST METHOD)

Test Equipment Needed:

- Amana power test kit R0157397 or
 - Menumaster power test kit M95D5.
1. Place one rack in the oven using lowest rack position.
 2. Fill the plastic container to the bottom of the 1000 ml. lines with cool tap water.
 3. Using the thermometer; Fahrenheit or Centigrade, stir the water, measure and record the water temperature. **IMPORTANT:** Initial water temperature should be approximately 60°F (20°C).
 4. Place the container on the center of the oven rack and heat the water for 62 seconds.
 - a. Close the door.
 - b. Press Hidden Pad, 1, 3, 5, 7, 9.
 - c. Press 3 to activate microwave mode.
 - d. Display counts up to 62 seconds, and unit shuts off.
 - e. Open the door.

5. Stir the water, measure and record the temperature of the water after heating time is completed.
6. Subtract the starting water temperature (Step 3) from the ending water temperature (Step 5) to obtain the temperature rise.
7. Refer to the Temperature Chart.

NOTE: Variation or errors in the test procedure will cause a variance in the temperature rise indication. Additional power tests should be made if temperature rise appears marginal.

NOTE: Low line voltage may cause lower power output (temperature rise).

NOTE: Always perform 3 tests for accuracy. Change water after each test.

Temperature Chart

ONE MINUTE, TWO SECONDS run time chart for units less than 1550 watts cooking power.

ΔT (°F)	Cooking Power Output	ΔT (°F)	Cooking Power Output
12	464	20	775
13	504	21	814
14	542	22	852
15	581	23	891
16	620	24	930
17	659	25	969
18	697	26	1007
19	736		

ΔT (°C)	Cooking Power Output	ΔT (°C)	Cooking Power Output
7	490	12	840
8	560	13	910
9	630	14	980
10	700	15	1050
11	770		

Test Modes

Convection Temperature Test

NOTE: It is absolutely necessary to own and use a thermocouple type oven tester to accurately measure oven temperature. No other type of thermometer can take its place.

NOTE: Before testing an oven to check calibration, inspect the RTD for proper mounting.

1. Place one wire rack in center position. Remove any other racks and utensils.
2. Clip thermocouple to the center rack and run lead outside oven door, or wrap thermocouple around rack and have tip of thermocouple extend upward towards top of cavity approximately 1".
3. Press *PREHEAT ON/OFF* pad.
4. Press *PROGRAM SAVE* pad.
5. Press *TEMP* pad.
6. Enter 450°F.
7. Allow oven to cycle one time.
8. Record high and low peaks from next two cycles.

NOTE: Display **does not** indicate if heating elements are on or off.

Example:

	<u>LOW</u>	<u>HIGH</u>
Cycle 1	440°F	460°F
Cycle 2	439°F	461°F
	879°F +	921°F = 1800°F

$$1800^{\circ}\text{F} / 4 = 450^{\circ}\text{F} \text{ average temperature}$$

If the average temperature is too high or too low the oven temperature offset needs to be calibrated.

Convection Temperature Calibration

NOTE: It is normal for the average oven temperature to vary from the oven setting by as much as 25°F. Difference will not effect cooking since recipes are written with this difference in mind.

Calibration

NOTE: Door must be closed.

1. Press *HIDDEN PAD*.
2. Press pads 1,3,5,7, 9.
3. Press "0" pad.



NOTE: Display will show the current offset setting.

4. Press the "0" pad to change the offset.

NOTE: Offset temperature range is +40°F to -40°F and advances in 2 and 3° increments.

5. Press *STOP/RESET* pad to save offset changes.

NOTE: Retest the oven after any offset changes are made.

Example:

- Oven temperature is set for 450°F
- Average of temperature test is 475°F
- Offset setting must be reduced by 25°F
- If offset is shown as 10°F, press the "0" pad until -15 is shown in the display (10 – 25 = -15)

Radiation Leakage Testing



WARNING

Check for radiation leakage after servicing. Should the leakage be more than 4mW/cm² inform Amana immediately. After repairing or replacing any radiation safety device, keep a written record for future reference, as required by D.H.H.S. and HEW regulations. This requirement must be strictly observed. In addition, the leakage reading must be recorded on the service repair ticket while at the customer's location.

Equipment

- Electromagnetic radiation monitor
- 600 cc glass beaker

Procedure For Measuring Radiation Leakage

Note before measuring -

- Do not exceed meter full scale deflection. Leak monitor should initially be set to the highest scale.
 - To prevent false readings the test probe should be held by the grip portion of the handle only.
 - The scan speed is equal to one inch per antenna revolution or one inch per second if antenna speed is unknown.
 - Areas to be checked are all door seal areas and any venting parts.
 - Leakage with the outer panel removed, 4mW/cm² or less.
 - Leakage for fully assembled oven with door normally closed, 4mW/cm² or less.
 - Leakage for a fully assembly oven (before the latch switch (primary) is interrupted) while pulling the door, 4mW/cm² or less.
1. Open the oven door and verify that there is only one rack in place on the bottom rack hooks.
 2. Pour 275 ± 15 cc (9 oz ± 1/2 oz) of 20 ± 5°C. (68± 9°F.) water in a glass beaker which is graduated to 600 cc and place the beaker in the center of rack.
 3. Set the radiation monitor to 2450 MHz and use it following the manufacturer's recommended test procedure to assure correct results.
 4. While measuring the leakage, always use the two inch (5 cm) spacer supplied with the probe.
 5. Press the start pad or turn on the timer and with the magnetron oscillating, measure the leakage by holding the probe perpendicular to the surface being measured.

Measurement With the Outer Case Removed



DANGER

To avoid risk of personal injury or death avoid contacting any high voltage components.

Whenever you replace the magnetron, measure for radiation leakage before the outer case is installed and after all necessary components are replaced or adjusted. Special care should be taken in measuring around the magnetron.

Measurement With a Fully Assembled Oven

After all components, including the outer panel are fully assembled, measure for radiation leakage around the door periphery, the door viewing window, the exhaust opening, and air inlet openings.

Record Keeping and Notification After Measurement

1. After any adjustment or repair to a microwave oven, a leakage reading must be taken. Record this leakage reading on the repair ticket even if it is zero.
2. A copy of the repair ticket and the microwave leakage reading should be kept by the repair facility.

Display Diagnostics

CAUTION

All repairs as described in this troubleshooting section are to be performed only after the caution procedures one through eight listed below have been followed.

1. Check grounding before checking for possible causes.
2. Be careful of the high voltage circuit.
3. Discharge high voltage capacitor.
4. When checking the continuity of the switches or the high voltage transformer, disconnect one lead wire from these parts and then check continuity with the AC plug removed. To do otherwise may result in a false reading or damage to your meter.
5. Do not touch any parts of the circuitry on the P.C. Board circuit since static electric discharge may damage this control panel. Always touch yourself to ground while working on this panel to discharge any static charge in your body.
6. 208/230 VAC is present in the high voltage circuit board, power relay and primary circuit of low voltage transformer.
7. When troubleshooting, be cautious of possible electrical hazard.
8. When testing convection operation, convection fan may start at any time or if oven is hot.

Error Codes

During operation, the display may show the following service codes:

NOTE: Before scheduling service for any error codes, instruct customer to unplug oven for 1 minute, reconnect power, and retest. If unit operates properly, no service call is required.

Display	Description	Corrective Action
Err1	Checksum Error	See note above. Replace H.V. board.
Err2	Hardware Problem	See note above. Verify wiring at H.V. board. If wiring is good, replace H.V. board.
Err3	Hardware Problem	See note above. Verify wiring at H.V. board. If wiring is good, replace H.V. board.
Err4	Hardware Problem	See note above. Check green jumper at J8 connector on H.V. board. If jumper is good, replace H.V. board.
Err5	Defective Touch Panel	See note above. If Touch Panel is pressed for more than 30 seconds, this error code will appear. Replace touch panel.
Err6	RAM Error	See note above. Replace H.V. board.
Err7	Error with RTD circuit If power level shows 0-Uncalibrated..... 1-Shorted RTD circuit 2-Open RTD circuit	See note above. Replace H.V. board. Check RTD and wiring to H.V. board. Check RTD and wiring to H.V. board.
HOT		See note above. Open TCO. Convection motor inoperative. Restricted air filter. H.V. board inoperative. Broken or loose wire.
Door	Door Interlock Primary Switch	See note above. Verify latch mechanism moves freely on door. Verify J1 connector on display board is properly seated. Test interlock switch assembly and perform door adjustment if necessary. Replace interlock switch assembly if failed.

Service Test

NOTE: Unit must be in STANDBY mode.

To Enter Service Mode, oven door must be closed.

NOTE: Pads will not beep when pressed.

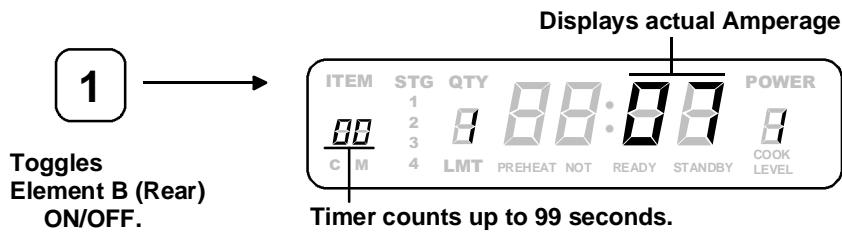
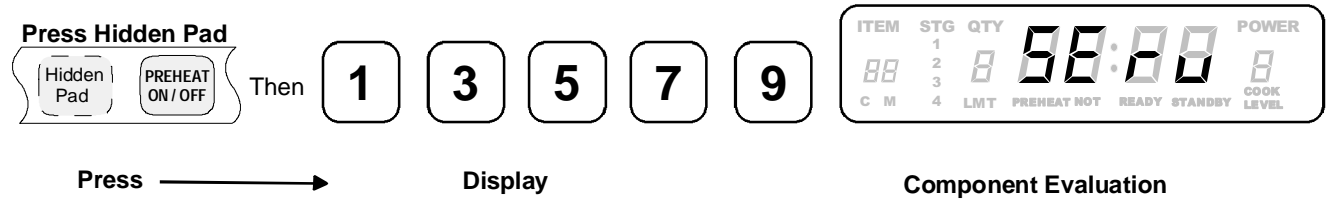

- If no Amperage, check:
- Heating element
 - Triac 2 (middle)
 - H.V. board (relay K9 and triac 2 drive voltage)
 - Wiring

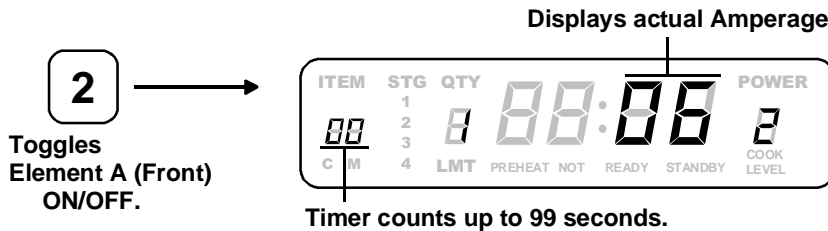

- If no Amperage, check:
- Heating element
 - Triac 1 (top)
 - H.V. board (relay K4 and triac 1 drive voltage)
 - Wiring

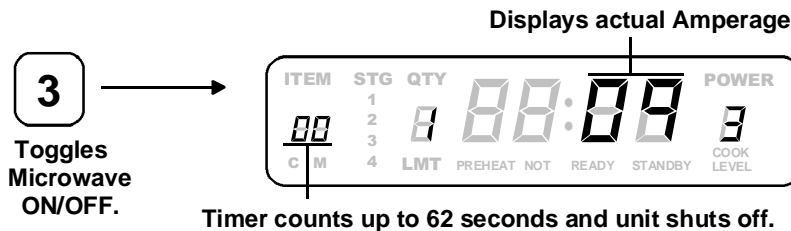

- If no Amperage, check for line voltage at H.V. transformer primary winding.
If no voltage, check:
- Interlock switch (secondary)
 - Magnetron TCO
 - Triac 3 (bottom)
 - H.V. board (relay K7 and triac 3 drive voltage)
 - Wiring
- If voltage is present, check H.V. components and wiring.

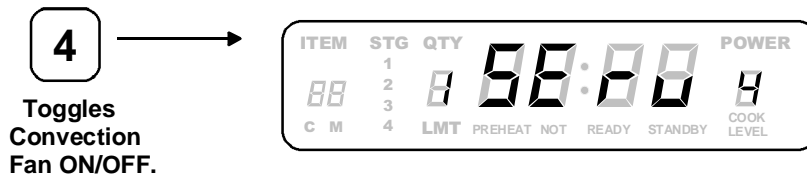

- If no fan operation, check:
- Convection fan motor and wheel
 - H.V. board (relay K2)
 - Wiring

Service Test

Press →

Display

Component Evaluation

5

Toggles Cooling Fan ON/OFF.



If no fan operation, check:

- Cooling fan motor and wheel
- H.V. board (relay K1)
- Wiring

6

Toggles Oven Light ON/OFF.



If no light operation, check:

- Oven light
- H.V. board (relay K3)
- Wiring

7

Displays # of Magnetron Hours.

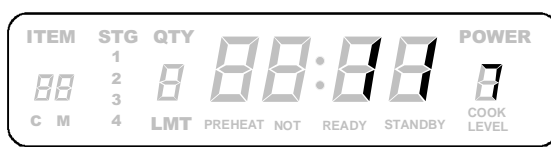

8

Displays # of Door Cycles with a 1 to 1 ratio rounded to the nearest ten



9

Clears Hours and Cycles (press START to activate) (Resets to 0).



0

Displays current Temperature OFFSET.



TEMP

Display current oven Temperature as sensed by RTD.

To Exit Service Mode Press



Troubleshooting

Power Up

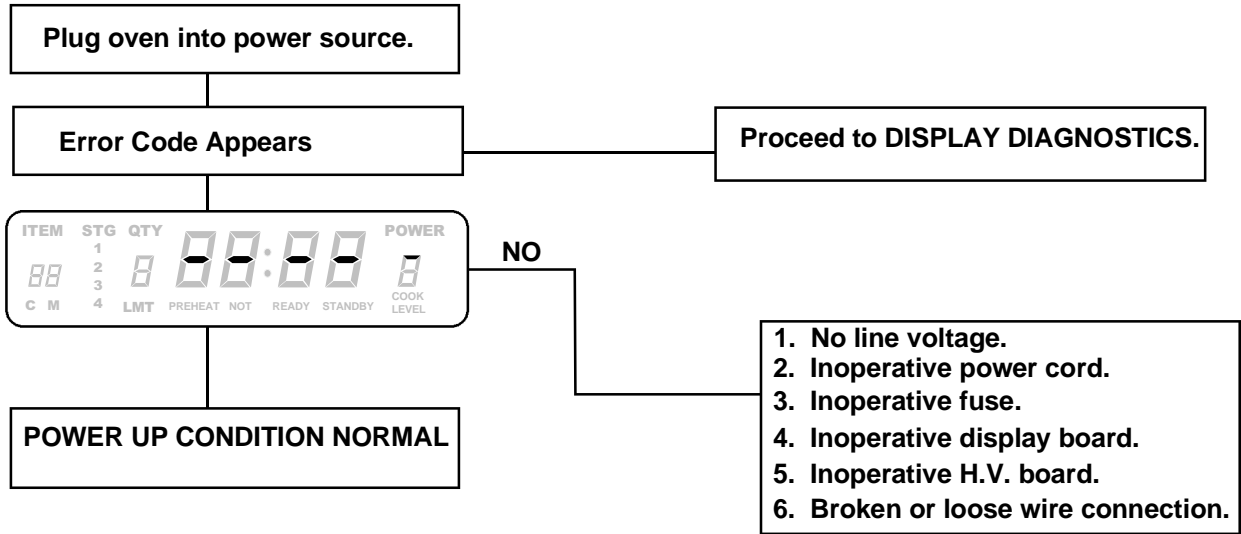

Preheat/Convection Condition

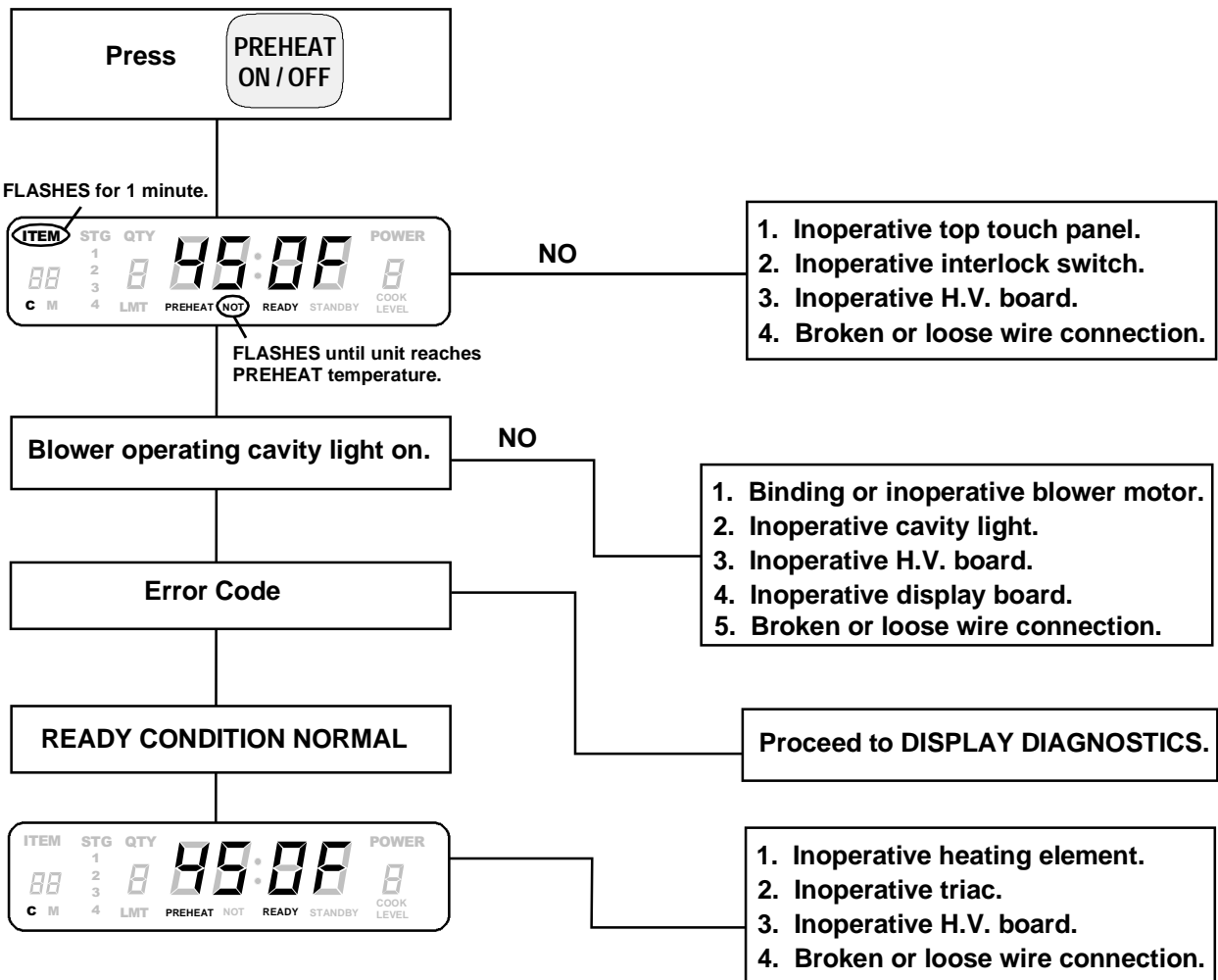

Troubleshooting

Microwave Condition

Open door, place cup of water in oven.
Close oven door.

Press **PREHEAT ON/OFF** **TIME** enter desired time **TEMP** enter 150°F **POWER LEVEL** enter desired microwave power level.

Press **START**

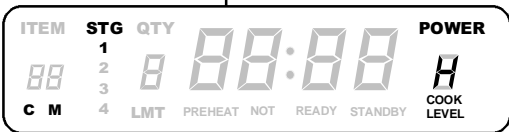

NO

1. Inoperative top touch panel.
2. Inoperative side touch panel.
3. Inoperative H.V. board.
4. Broken or loose wire connection.

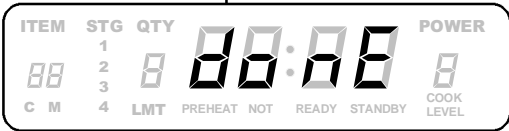

End of cycle tone sounds.

Open door and remove water.
Is water heated?

NO

- Heats Slowly**
1. Inoperative or misadjusted interlock switch module.
 2. Inoperative magnetron.
 3. Inoperative thermal cutout.
 4. Broken or loose wire connection.
- No Heat**
1. Inoperative or misadjusted interlock switch module.
 2. Inoperative thermal cutout.
 3. Inoperative triac.
 4. Inoperative diode.
 5. Inoperative capacitor.
 6. Inoperative H.V. transformer.
 7. Inoperative magnetron.
 8. Broken or loose wire connection.

YES

**MICROWAVE CONDITION
OPERATING PROPERLY**

Disassembly



WARNING

To avoid the risk of electrical shock, personal injury, or death, disconnect power to oven and discharge capacitors before following any disassembly procedure.

Door Handle

Remove door handle by removing plastic plugs to gain access to set screws. Loosen set screws using a (3/32 inch allen screws), one located to the left of the door handle and one located on the bottom of the door handle.

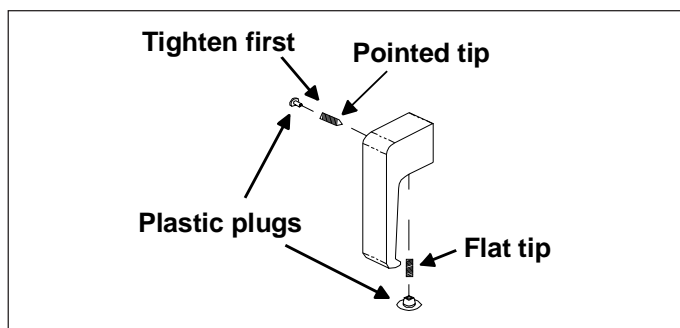

NOTE: When replacing door handle, tighten side set screw first.

NOTE: If set screws are removed, the set screw with the flat end must be used in the bottom of the door handle.

Outer Door

1. Remove door handle.
2. Remove plastic plugs covering screws with a thin flat blade screwdriver.
3. Remove crows foot screws using crows foot driver (92113P01), securing outer door to inner door assembly.
4. Remove outer door from inner door assembly.
5. Reassemble outer door in reverse order.

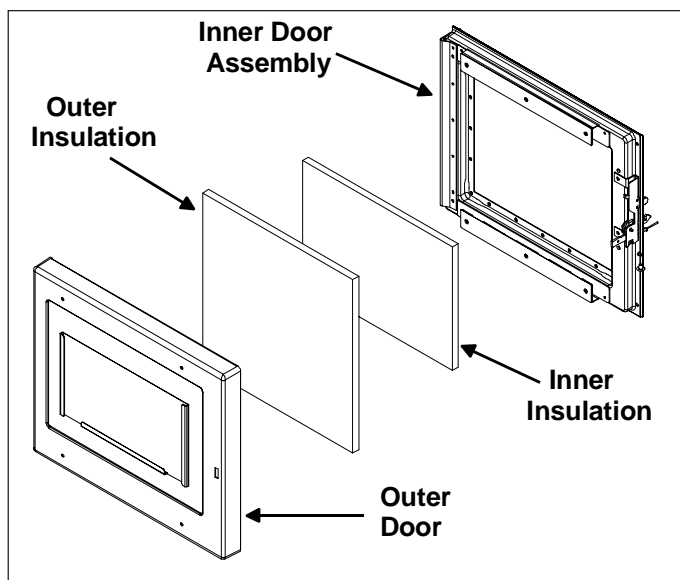

Inner Door Assembly

1. Remove door handle.
2. Remove outer door.
3. Remove insulation pads from inner door assembly.
4. Remove screws securing inner door assembly to hinge.
5. Reassemble inner door assembly in reverse order.

Hinge

1. Remove outer case.
2. Remove door handle.
3. Remove outer door assembly.
4. Remove hinge mounting screws from hinge (five on front, four on side).

NOTE: Discard foam gasket on side of hinge.

5. When reinstalling hinge mounting screws, keep the side screws loose and the front screws tight, close door, press door against oven on the hinge side and tighten side hinge mounting screws in the sequence shown below.

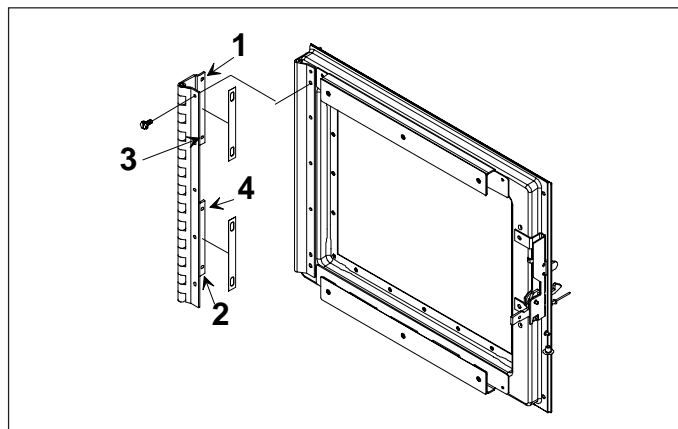

Disassembly



WARNING

To avoid the risk of electrical shock, personal injury, or death, disconnect power to oven and discharge capacitors before following any disassembly procedure.

Outer Case

1. Remove screws securing outer case to chassis, see illustration below.
2. Slide outer case back and lift off.
3. Reassemble outer case in reverse order.

Back Panel

1. Remove outer case.
2. Remove screws securing back panel.
3. Reassemble back panel in reverse order.

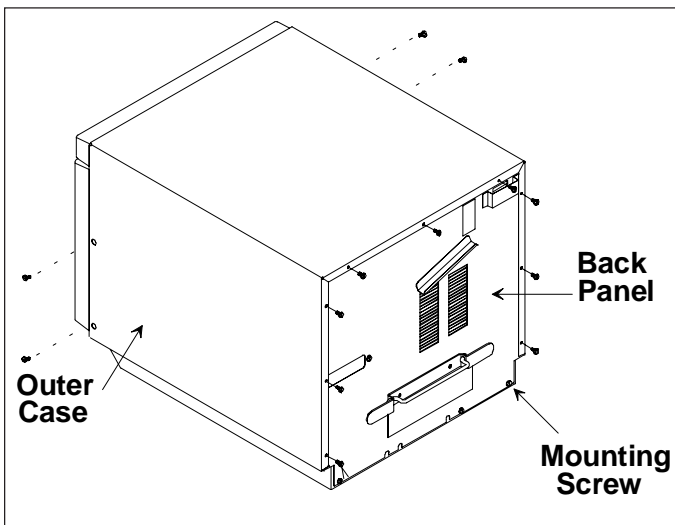

Stirrer Cover

1. See "Component Location" Figure 4, for location.
2. Unplug oven before removing stirrer cover to access stirrer assembly.
3. Loosen screw securing stirrer cover mounting clip and rotate clip to the side.
4. Slowly lower front of stirrer cover, then pull gently towards front of unit to release cover.
5. Replace stirrer cover by fitting stirrer blade on stirrer insert. Place back of stirrer cover into place, align stirrer insert onto stirrer shaft. Lift front of cover into position, rotate mounting clip into position, tighten screw.



CAUTION

If mounting clip is loose arcing will occur.

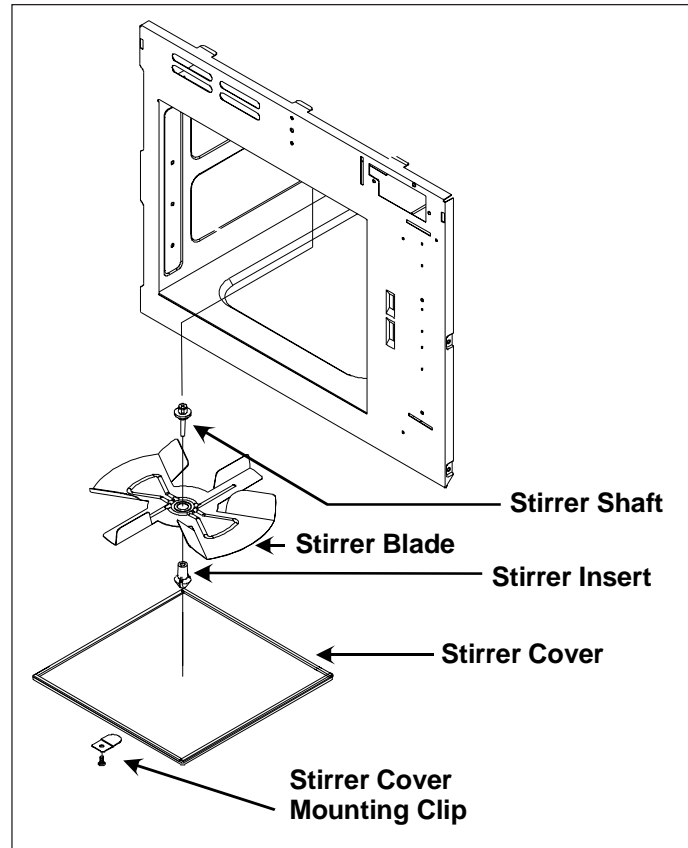

RTD (Resistance Thermal Device)

1. See "Component Location" Figure 4, for location.
2. Remove outer case.
3. Disconnect RTD harness connector.
4. Remove mounting screw located inside oven.
5. Lift RTD from top of the oven.
6. Reassemble RTD in reverse order.

Top Touch Panel Assembly

1. See "Component Location" Figure 1, for location.
2. Remove outer case.
3. Disconnect all wire connectors at display board.
4. Remove screws securing top touch panel to unit.
5. Remove screws securing display board to top touch panel assembly.
6. Reassemble touch panel in reverse order.

Disassembly



WARNING

To avoid the risk of electrical shock, personal injury, or death, disconnect power to oven and discharge capacitors before following any disassembly procedure.

Side Touch Panel Assembly

1. See "Component Location" Figure 1, for location.
2. Remove outer case.
3. Remove ribbon cable from display board.
4. Remove mounting screws securing side touch panel to unit.
5. Reassemble touch panel in reverse order.

High Voltage Circuit Board

1. See "Component Location" Figure 2, for location.
2. Remove outer case.
3. Unplug connectors.
4. Disconnect wires from terminal locations on H.V. board.
5. Release mounting clips and remove board.
6. Reassemble high voltage board in reverse order.

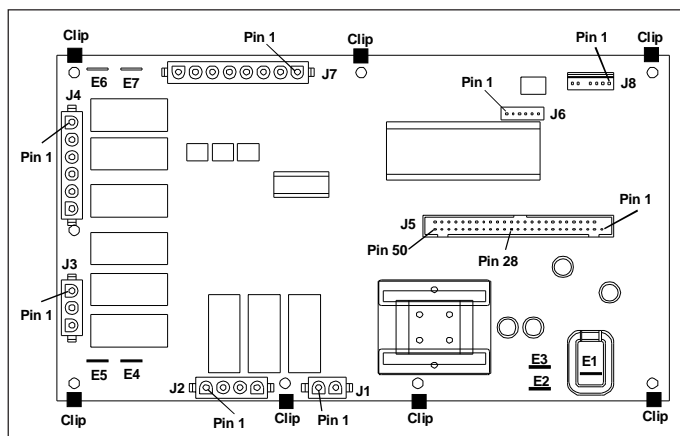

NOTE: When reassembling, verify cable connection with illustration of cable locations.

Interlock Switch Module

1. See "Component Location" Figure 2, for location.
2. Remove outer case.
3. Disconnect wiring from interlock switch assembly.
4. Remove mounting screws securing interlock switch.
5. When replacing assembly, all wires must be connected before operating oven.

NOTE: When the line fuse is blown **interlock switch module** must be replaced.

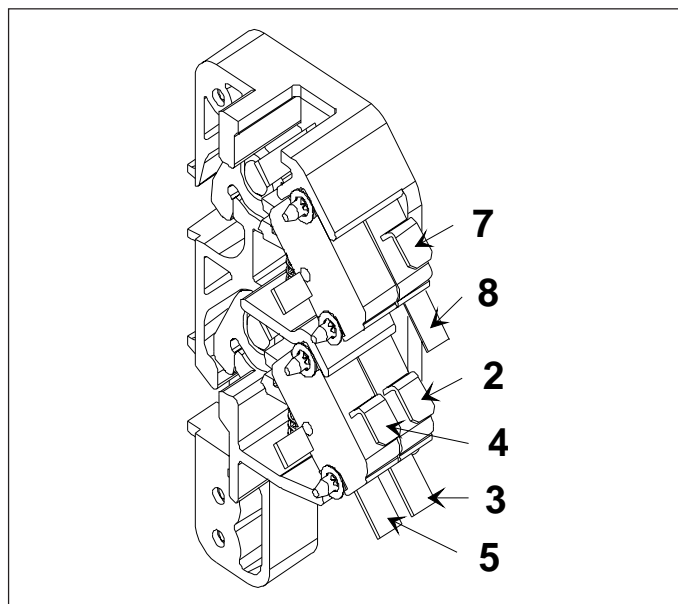

Adjustment

1. To adjust interlock switch assembly, close door.
2. Loosen bottom and top screw on the interlock switch assembly, allowing switch assembly to move in or out.
3. With door closed, push forward on interlock assembly to engage door latch. Then pull back on interlock assembly until door is "snug" against front oven cavity and tighten bottom screw first, then top screw.
4. Door will remain latched when proper adjustment is made.

NOTE: If door is not properly adjusted display will indicate *DOOR* when the door is closed.

Disassembly



WARNING

To avoid the risk of electrical shock, personal injury, or death, disconnect power to oven and discharge capacitors before following any disassembly procedure.

Display Module

1. See "Component Location" Figure 1, for location.
2. Remove outer case.
3. Remove top touch panel, see Top Touch Panel Assembly procedure.
4. Reassemble display module in reverse order.

Magnetron

1. See "Component Location" Figure 3, for location.
2. Remove outer case.
3. Remove screws securing magnetron inlet cover and remove cover.
4. Remove screws securing waveguide duct.
5. Remove wires from magnetron.
6. Remove allen screws securing magnetron thermal cutout bracket to magnetron.
7. Remove magnetron mounting nuts and remove front magnetron cover bracket..
8. Remove magnetron.
9. When replacing magnetron, verify wire mesh gasket is reinstalled properly.

NOTE: When reinstalling magnetron, slide air baffle inside magnetron before mounting magnetron in place.

NOTE: Place front magnetron cover bracket in place before securing magnetron.

Magnetron, Control, and Fan Thermal Cutout (TCO)

1. See "Component Location" Figure 3, for location.
2. Remove outer case.
3. Remove wiring from selected thermal cutout.
4. Remove screws securing thermal cutout.
5. Reassemble thermal cutout in reverse order.

Triacs

1. See "Component Location" Figure 1, for location.
2. Remove outer case and back panel.
3. Remove wires from terminals of selected triac.
4. Remove screws securing triac to chassis.
5. Reassemble triac in reverse order.

Microwave Blower Wheel and Motor

1. Remove outer case and back panel.
2. Remove wiring from blower motor terminals.
3. Remove screws securing blower assembly to bracket.
4. Remove assembly from oven.
5. Loosen allen set screw securing blower wheel to motor shaft.
6. Remove blower wheel.
7. Remove screws securing motor to scroll.
8. Reassemble blower wheel and motor in reverse order.

NOTE: When reinstalling blower wheel, push blower wheel on shaft, tighten, and rotate to insure clearance between blower wheel, and blower housing.

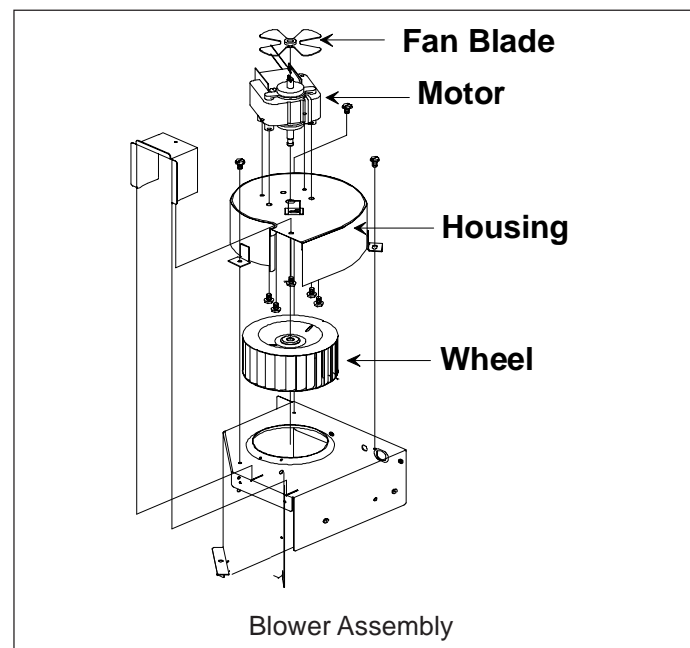

Disassembly



WARNING

To avoid the risk of electrical shock, personal injury, or death, disconnect power to oven and discharge capacitors before following any disassembly procedure.

Fan Blade

1. Pull blade off shaft.
2. When reinstalling blade, push blade on shaft and rotate to insure clearance between fan blade and motor mounting bolt.

Transformer

1. See “Component Location” Figure 3, for location.
2. Remove outer case and back panel.
3. Remove screws securing transformer to chassis.
4. Pry upward and back to release transformer from chassis.
5. Remove wire connections from transformer.

NOTE: When placing transformer back into chassis. Front portion of transformer **must** slide into base pan tab.

6. Reassemble transformer in reverse order.

Capacitor

1. See “Component Location” Figure 2, for location.
2. Remove outer case and back panel.
3. Discharge capacitor and remove wires from terminals.
4. Remove capacitor bracket mounting screw.
5. Reassemble capacitor in reverse order.

NOTE: Capacitor case must be installed into indent in back panel.

Heater Box

1. See “Component Location” Figure 3, for location.
2. Remove outer case and back panel.
3. Remove wires connected to heating elements, convection fan, and control thermal cutout.
4. Remove screws securing heater box.
5. Slide heater box sideways from chassis.
6. Reassemble heater box in reverse order

Heating Elements

1. See “Component Location” Figure 5, for location.
2. Remove outer case and back panel.
3. Remove heater box.
4. Remove screws securing heater assembly to heater box.
5. Reassemble heating element in reverse order.

NOTE: Center heating element around convection fan blade.

Convection Fan and Motor

1. See “Component Location” Figure 5, for location.
2. Remove outer case and back panel.
3. Remove heater box.
4. Remove left handed threaded nut on fan blade, and slide fan off.
5. Remove screws securing convection motor to heater box.
6. Reassemble convection motor in reverse order.

Fuse

1. See “Component Location” Figure 2, for location.
2. Remove outer case.
3. Replace fuse and reassemble in reverse order.

Disassembly



WARNING

To avoid the risk of electrical shock, personal injury, or death, disconnect power to oven and discharge capacitors before following any disassembly procedure.

Power Cord

1. See "Component Location" Figure 3, for location.
2. Remove outer case and back panel.
3. Disconnect wiring.
4. Remove strain relief by compressing with pliers.
5. Remove power cord.
6. Reassemble power cord in reverse order.

Light Socket

1. Remove outer case.
2. Remove screws securing lamp cover bracket.
3. Unscrew light bulb from socket.
4. Disconnect wire terminals to light socket.
5. Remove screw securing light socket to light retainer.
6. Reassemble light socket in reverse order.

Replacing Oven Light Bulb



WARNING

To avoid electrical shock which can cause severe personal injury or death, unplug power cord or open circuit breaker to oven before replacing light bulb. After replacing light bulb, restore power.



CAUTION

To avoid personal injury or property damage, observe the following:

- Allow oven and light bulb to cool.
- Wear gloves when replacing light bulb.

Tools Needed

- Protective gloves
- Phillips screwdriver
- 40-watt, 250-volt appliance bulb (available from authorized distributor or servicer)

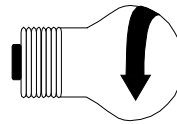

To remove bulb, turn in direction shown.

1. Remove screw from access cover on top left wall of oven exterior. Remove access cover.
2. Remove old bulb and replace with new bulb.
3. Replace access cover and screw by reversing procedure in step 1.

Disassembly



WARNING

To avoid the risk of electrical shock, personal injury, or death, disconnect power to oven and discharge capacitors before following any disassembly procedure.

Component Location

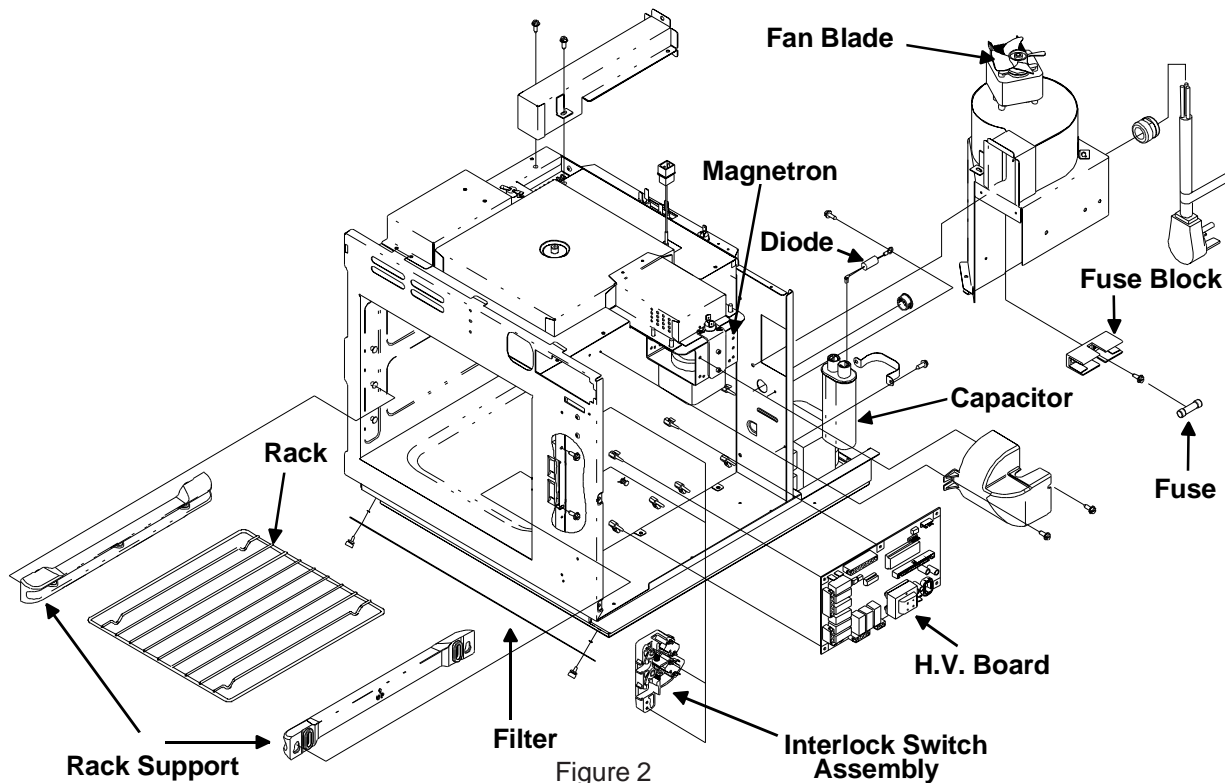
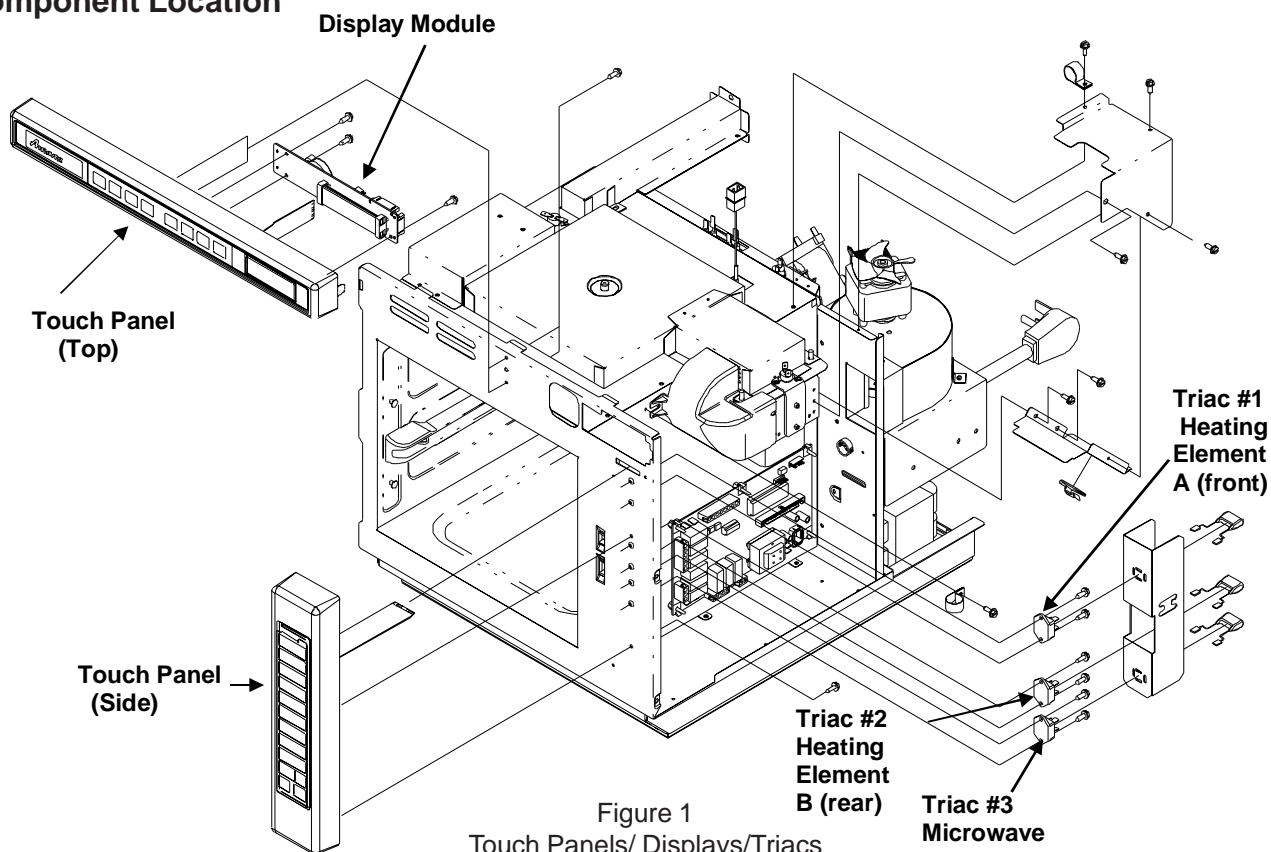

Disassembly



WARNING

To avoid the risk of electrical shock, personal injury, or death, disconnect power to oven and discharge capacitors before following any disassembly procedure.

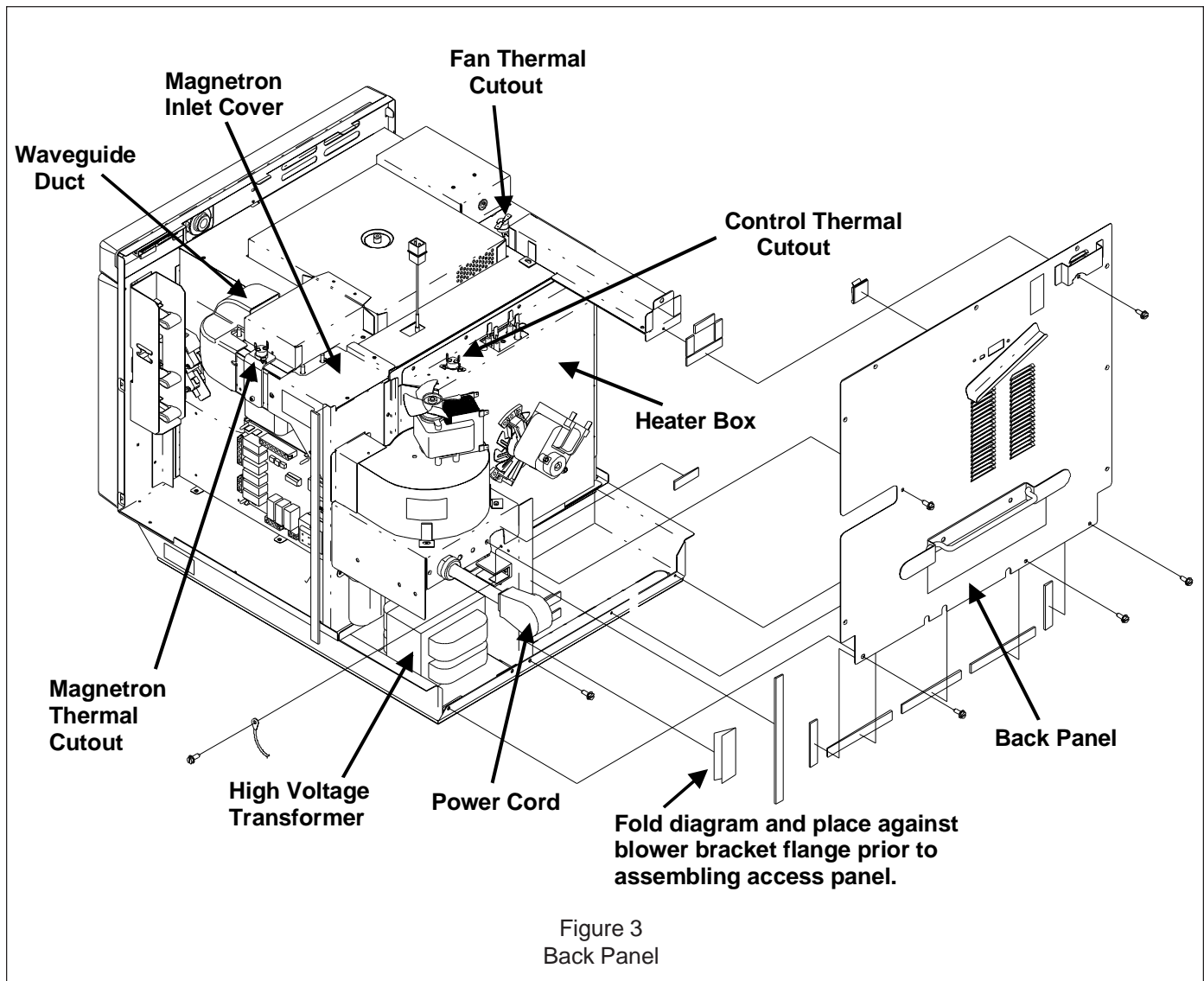

Disassembly



WARNING

To avoid the risk of electrical shock, personal injury, or death, disconnect power to oven and discharge capacitors before following any disassembly procedure.

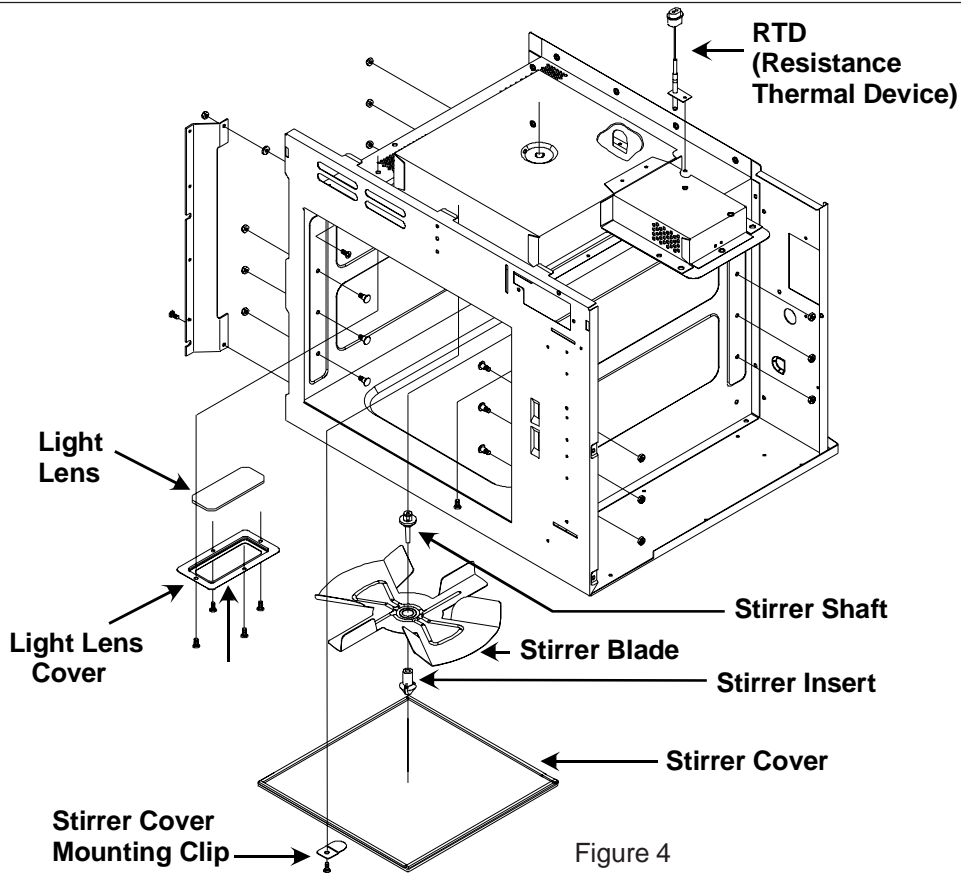

Figure 4
Stirrer Assembly

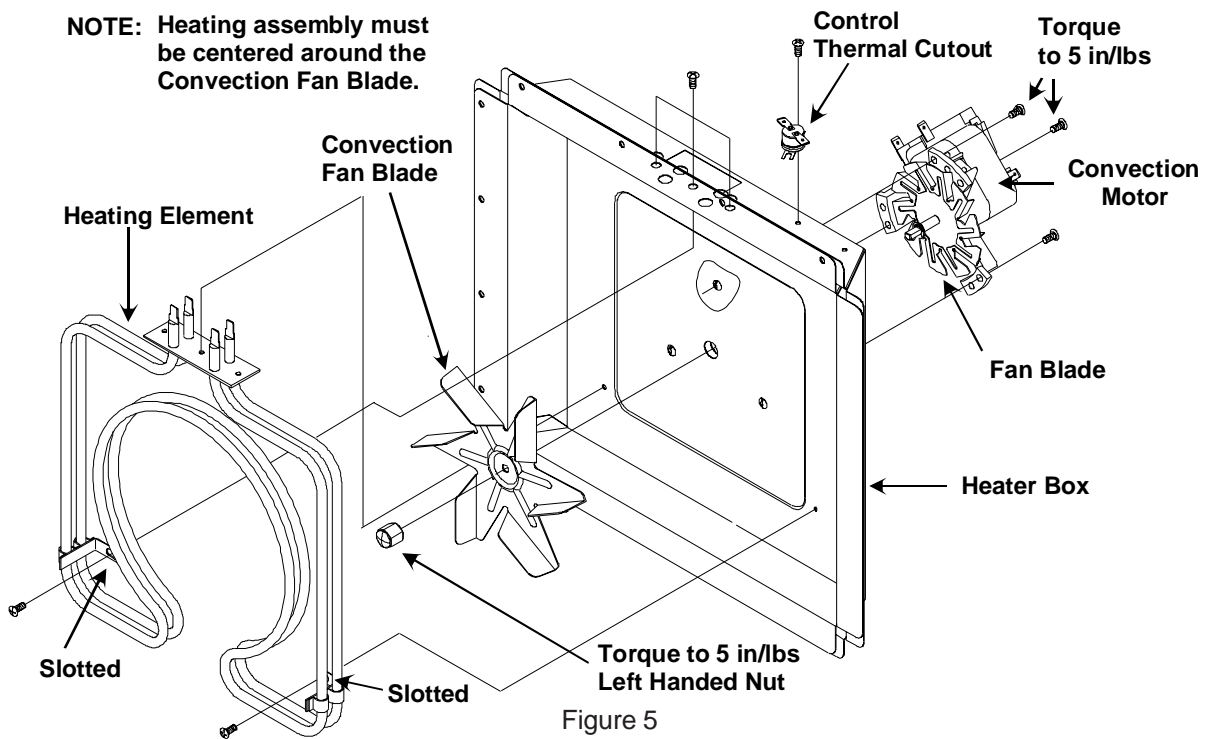

Figure 5
Heater Assembly