

AyrKing Corporation

Breader/Blender/Sifter



AyrKing offers an automatic Blender/Sifter machine for hand breading operations. Rotary brush sifter operates without detrimental vibration or agitation. Spirally configured nylon bristles form an auger to eject unwanted dough balls to a waste container. Ingredients are fully blended as brush tumbles breading media before it exits through sifter screen. Unique process prevents dough ball grinding, eliminates usual sifting noise, & blends ingredients as it ejects waste. The sifter machine is mountable to any customized s/s worktable. Sifter orientation is specified either right or left.

Photo of BBS-U-RHW



INCLUDED ACCESSORIES

- B101 Red plastic lug plug
- B302 White plastic breading lug with hole
- B303 White plastic breading lug without hole
- B325 White plastic lug cover
- B304 White plastic dough ball pan
- B122 Round dip basket, stainless steel wire
- B123 Round dip pot, stainless steel

OPTIONAL ACCESSORIES

- B126 Feathering basket, stainless steel wire
- B124 Round dip pot lid, stainless steel
- B302G Gray plastic breading lug with hole
- B303G Gray plastic breading lug without hole
- B325G Gray plastic lug cover



ADVANTAGES

Sift and blend 30 lbs (14 kg) of breading in 60 seconds!

Rotary auger brush blends, sifts, and ejects dough balls simultaneously

Blending brush action prevents ingredient segregation, unlike vibrating or agitating systems

Quiet, vibration-free operation creates results, not disturbances

Sixty second timed cycle frees labor and saves energy

Raised s/s lip around sifter opening prevents tabletop spills from contaminating sifted breading

Fully enclosed sifter with only four internal parts, reduces dust and allows quick and easy cleaning

Direct drive, steel geared motor & solid stainless steel fabrication provide lasting performance

MODEL

BBS-U-RHW Breader/Blender/Sifter machine assembled with RIGHT SIDE motor compartment

BBS-U-LHW Breader/Blender/Sifter machine assembled with LEFT SIDE motor compartment

AyrKing Corporation
2013 Cobalt Drive
Louisville, KY 40299-2417

Telephone 502-266-6270
Facsimile 502-266-6274
www.ayrking.com

AyrKing Corporation

Breader/Blender/Sifter

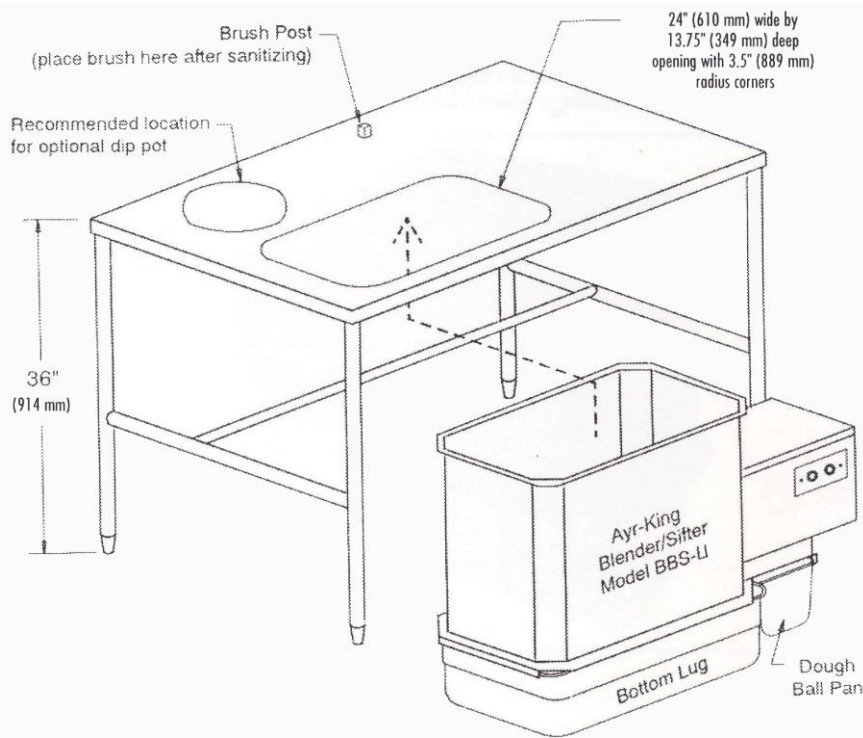

- 1) Locate BRUSH POST in a non-intrusive position on the tabletop. The post facilitates overnight air-drying of brush after cleaning to prevent flattening of brush bristles. Minimum of 4" (10cm) clearance all around post to keep bristles clear of any contact. As an alternative, a brush post is also available to hang on typical metal shelving (part #B219H).
- 2) Recommend angle framing under the perimeter of the tabletop and above the sifter motor compartment area to support the weight load of the sifter hanging down from the tabletop.
- 3) Welded studs should be used to fasten the sifter to the underside of the tabletop. No fasteners should be exposed on the tabletop surface.
- 4) Continuous bead of food grade silicone should be applied to the seam between the tabletop and the sifter machine enclosure where the two mate together.
- 5) An approximate 3/16" (5mm) high continuous lip should be bent up around perimeter of the sifter opening in tabletop to create a barrier for table surface contaminants from entering sifter.
- 6) The motor and/or motor compartment cannot be altered or field located to a different location.
- 7) Only order black sifter brush replacements from AyrKing, model B150.

CARTON MEASUREMENTS

MODEL	LENGTH	WIDTH	HEIGHT	WEIGHT	UNCRATED
BBS-U	41" (1040mm)	20" (510mm)	28" (700mm)	93 lb (42kg)	86 lb (39kg)

ELECTRICAL

Timed control board automatically senses voltage & operates at either:
 115V, 50/60Hz, 1 phase, 1.6 AMP, 184W
 230V, 50/60Hz, 1 phase, 0.9 AMP, 207W
 Includes universal male three prong, recessed
 AC receptacle (IEC 320 C13) mating to an 8 foot
 (2438mm) cord with NEMA 5-15P male three prong plug

WARRANTY

One Year Parts
 Ninety Days Labor
 No Travel Time

Specifications subject to change without notice. Version 05/19

AyrKing Corporation
 2013 Cobalt Drive
 Louisville, KY 40299-2417

Telephone 502-266-6270
 Facsimile 502-266-6274
 www.ayrking.com

