

e-90E Smart Pump

Close-Coupled In-Line Centrifugal Pumps

Table of Contents

1	Introduction and Safety.....	3
1.1	Introduction.....	3
1.2	Safety.....	3
1.2.1	Safety terminology and symbols.....	3
1.2.2	User safety.....	4
1.2.3	Protecting the environment.....	5
2	Transportation and Storage.....	6
2.1	Examine the delivery.....	6
2.1.1	Examine the package.....	6
2.1.2	Examine the unit.....	6
2.2	Pump lifting.....	6
2.3	Long-term storage.....	7
3	Product Description.....	8
3.1	General description.....	8
3.2	Operational specifications.....	8
3.3	Data plates.....	8
3.3.1	Motor specifications.....	9
3.3.2	Motor type data.....	9
3.4	Design and layout.....	11
3.5	Nomenclature.....	13
4	Installation.....	14
4.1	Preinstallation.....	14
4.1.1	Pump location guidelines.....	14
4.1.2	Unit installation.....	15
4.1.3	Piping checklist.....	16
4.1.4	Typical installation.....	17
4.2	Electrical installation.....	17
4.2.1	Electrical requirements.....	17
4.3	Wire types and ratings.....	18
4.4	Power supply connection.....	19
5	Commissioning, Startup, Operation, and Shutdown.....	24
5.1	Preparation for startup.....	24
5.1.1	Check the rotation.....	24
5.2	Lubrication requirements.....	25
5.3	Wait times.....	25
5.4	System setup and operation.....	25
5.4.1	Programming precautions.....	25
5.4.2	Control panel description.....	25
5.4.3	Push button descriptions.....	26
5.4.4	LED description.....	26
5.4.5	Display.....	28
5.4.6	Software parameters.....	30
5.5	Prime the pump.....	41
5.6	Start the pump.....	41
5.7	Pump operation precautions.....	42
5.8	Shut down the pump.....	42

- 6 Maintenance.....43
 - 6.1 Disassembly..... 43
 - 6.1.1 Disassembly precautions..... 43
 - 6.1.2 Drain the pump..... 44
 - 6.1.3 Typical cross section.....44
 - 6.1.4 Remove the seal assembly for all sizes.....45
 - 6.2 Pre-assembly inspections.....45
 - 6.2.1 Replacement guidelines.....45
 - 6.3 Reassembly.....46
 - 6.3.1 Reassemble the seal assembly..... 46
 - 6.3.2 Capscrew torque values..... 46
 - 6.3.3 Dealer servicing 47

- 7 Troubleshooting..... 48
 - 7.1 Alarm codes.....48
 - 7.2 Error codes..... 48

- 8 Technical Specification..... 51
 - 8.1 Electrical and environmental specifications.....51
 - 8.2 Dimensions and weights.....53

- 9 Cybersecurity..... 55

- 10 Product Warranty..... 57

1 Introduction and Safety

1.1 Introduction

Purpose of this manual

The purpose of this manual is to provide necessary information for:

- Installation
- Operation
- Maintenance



CAUTION:

Read this manual carefully before installing and using the product. Improper use of the product can cause personal injury and damage to property, and may void the warranty.

NOTICE:

Save this manual for future reference, and keep it readily available at the location of the unit.

Requesting other information

Special versions can be supplied with supplementary instruction leaflets. See the sales contract for any modifications or special version characteristics. For instructions, situations, or events that are not considered in this manual or in the sales documents, please contact the nearest Xylem representative.

Always specify the exact product type and identification code when requesting technical information or spare parts .

1.2 Safety



WARNING:

- The operator must be aware of safety precautions to prevent physical injury.
 - Operating, installing, or maintaining the unit in any way that is not covered in this manual could cause death, serious personal injury, or damage to the equipment. This includes any modification to the equipment or use of parts not provided by Xylem. If there is a question regarding the intended use of the equipment, please contact a Xylem representative before proceeding.
 - Do not change the service application without the approval of an authorized Xylem representative.
-



CAUTION:

You must observe the instructions contained in this manual. Failure to do so could result in physical injury, damage, or delays.



1.2.1 Safety terminology and symbols

About safety messages

It is extremely important that you read, understand, and follow the safety messages and regulations carefully before handling the product. They are published to help prevent these hazards:



- Personal accidents and health problems
- Damage to the product and its surroundings
- Product malfunction

Hazard levels

Hazard level	Indication
 DANGER:	A hazardous situation which, if not avoided, will result in death or serious injury
 WARNING:	A hazardous situation which, if not avoided, could result in death or serious injury
 CAUTION:	A hazardous situation which, if not avoided, could result in minor or moderate injury
NOTICE:	Notices are used when there is a risk of equipment damage or decreased performance, but not personal injury.

Special symbols

Some hazard categories have specific symbols, as shown in the following table.

Electrical hazard	Magnetic fields hazard
 Electrical Hazard:	 CAUTION:

1.2.2 User safety

General safety rules

These safety rules apply:

- Always keep the work area clean.
- Pay attention to the risks presented by gas and vapors in the work area.
- Avoid all electrical dangers. Pay attention to the risks of electric shock or arc flash hazards.
- Always bear in mind the risk of drowning, electrical accidents, and burn injuries.

Safety equipment

Use safety equipment according to the company regulations. Use this safety equipment within the work area:

- Hard hat
- Safety goggles, preferably with side shields
- Protective shoes
- Protective gloves
- Gas mask
- Hearing protection
- First-aid kit
- Safety devices

NOTICE:

Never operate a unit unless safety devices are installed. Also see specific information about safety devices in other chapters of this manual.

Electrical connections

Electrical connections must be made by certified electricians in compliance with all international, national, state, and local regulations. For more information about requirements, see sections dealing specifically with electrical connections.

Precautions before work

Observe these safety precautions before you work with the product or are in connection with the product:

- Provide a suitable barrier around the work area, for example, a guard rail.
- Make sure that all safety guards are in place and secure.
- Make sure that you have a clear path of retreat.
- Make sure that the product cannot roll or fall over and injure people or damage property.
- Make sure that the lifting equipment is in good condition.
- Use a lifting harness, a safety line, and a breathing device as required.
- Allow all system and pump components to cool before you handle them.
- Make sure that the product has been thoroughly cleaned.
- Disconnect and lock out power before you service the pump.
- Check the explosion risk before you weld or use electric hand tools.

1.2.2.1 Wash the skin and eyes

Follow these procedures for chemicals or hazardous fluids that have come into contact with your eyes or your skin:

Condition	Action
Chemicals or hazardous fluids in eyes	<ol style="list-style-type: none"> 1. Hold your eyelids apart forcibly with your fingers. 2. Rinse the eyes with eyewash or running water for at least 15 minutes. 3. Seek medical attention.
Chemicals or hazardous fluids on skin	<ol style="list-style-type: none"> 1. Remove contaminated clothing. 2. Wash the skin with soap and water for at least 1 minute. 3. Seek medical attention, if necessary.

1.2.3 Protecting the environment**Emissions and waste disposal**

Observe the local regulations and codes regarding:

- Reporting of emissions to the appropriate authorities
- Sorting, recycling and disposal of solid or liquid waste
- Clean-up of spills

Exceptional sites**CAUTION: Radiation Hazard**

Do NOT send the product to Xylem if it has been exposed to nuclear radiation, unless Xylem has been informed and appropriate actions have been agreed upon.

Recycling guidelines

Always follow local laws and regulations regarding recycling.

2 Transportation and Storage

2.1 Examine the delivery

2.1.1 Examine the package

1. Examine the package for damaged or missing items upon delivery.
2. Record any damaged or missing items on the receipt and freight bill.
3. If anything is out of order, then file a claim with the shipping company.
If the product has been picked up at a distributor, make a claim directly to the distributor.

2.1.2 Examine the unit

1. Remove packing materials from the product.
Dispose of all packing materials in accordance with local regulations.
2. To determine whether any parts have been damaged or are missing, examine the product.
3. If applicable, unfasten the product by removing any screws, bolts, or straps.
Use care around nails and straps.
4. If there is any issue, then contact a sales representative.

2.2 Pump lifting



WARNING:

- Assembled units and their components are heavy. Failure to properly lift and support this equipment can result in serious physical injury and/or equipment damage. Lift equipment only at the specifically identified lifting points. Lifting devices such as eyebolts, slings, and spreaders must be rated, selected, and used for the entire load being lifted.
 - Crush hazard. The unit and the components can be heavy. Use proper lifting methods and wear steel-toed shoes at all times.
-

In order to lift the entire pump, use slings placed around the unit as shown.

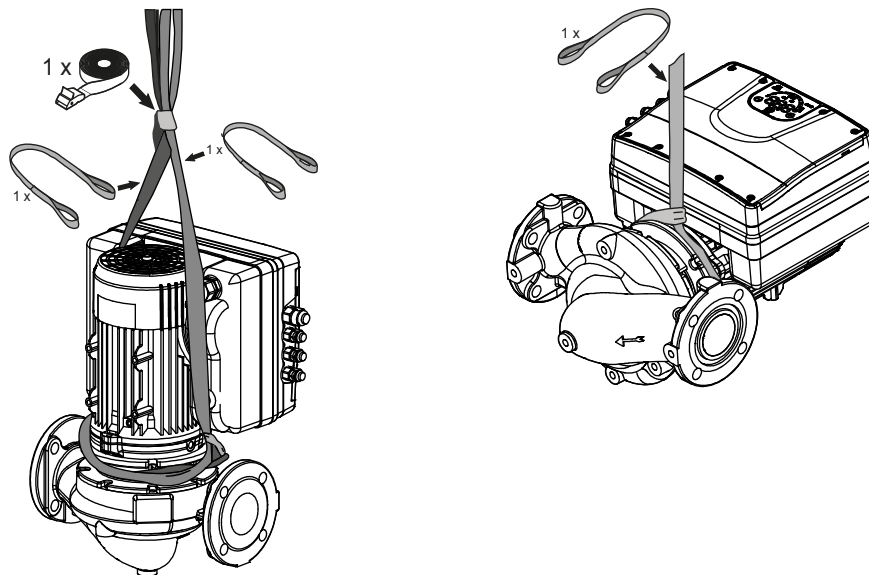

Figure 1: Proper lifting method

2.3 Long-term storage

If the unit is stored for more than 6 months, these requirements apply:

- Store in a covered and dry location.
- Store the unit free from heat, dirt, and vibrations.
- Store at an ambient temperature between -13°F and +149°F (-25°C and +65°C) and relative humidity between 5% and 95%.
- Rotate the shaft by hand several times at least every three months.

For questions about possible long-term storage treatment services, please contact your local sales and service representative.

3 Product Description

3.1 General description

The [Series e-90](#) in-line mounted centrifugal pump is a close-coupled pump. This pump is available for pipe sizes that range from 1 in to 3 inches.

Pump application



WARNING:

This product can expose you to chemicals including Lead, which is known to the State of California to cause cancer and birth defects or other reproductive harm. For more information go to: www.P65Warnings.ca.gov.

You can use this pump for these types of applications:

- Hydronic heating and cooling
- Potable hot water (all bronze construction only)
- Cooling towers
- Machinery cooling
- Pressure boosting
- Industrial fluid transfer
- Refrigeration and heat exchanger circulation

This pump is for indoor use only.

B&G recommends that you use all bronze constructed pumps for pumping potable water. For other applications, contact your local sales and service representative.

3.2 Operational specifications

Mechanical seal specifications

Materials of Construction	EPR carbon/silicon carbide	EPR SiC/SiC	Viton carbon/silicon carbide
Standard/optional	Standard	Optional	Optional
Operating temperature range	-20°F to 250°F (-29°C to 121°C)	0°F to 250°F (-18°C to 121°C)	0°F to 250°F (-18°C to 121°C)
pH range	7.0–11.0	7.0–12.0	7.0–12.0
Maximum glycol/water concentration	50/50%	60/40%	50/50%
Maximum suction pressure	Suction Pressure + TDH must not exceed MWP		

3.3 Data plates

The data plate is a label showing:

- The main product details
- The identification code

Approval and certifications

For the approvals see the motor data plate.

3.3.1 Motor specifications

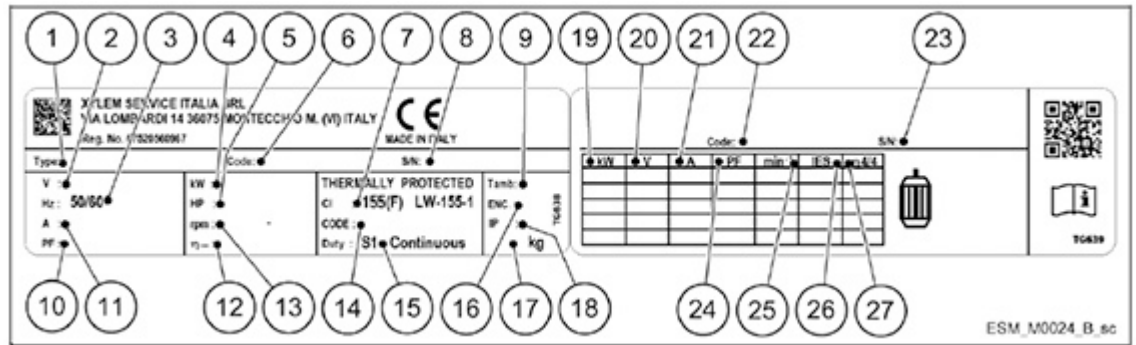

1. Type definition code
2. Rated voltage
3. Rated frequency
4. Rated power [kW]
5. Rated power [HP]
6. Part number
7. Insulation class
8. Serial number
9. Maximum ambient temperature
10. Power factor
11. Rated current
12. Motor drive efficiency
13. Full power speed range
14. Code letter for locked rotor
15. Duty type
16. Enclosure type (NEMA)
17. Weight
18. Protection class
19. Shaft power
20. Voltage
21. Current
22. Part number
23. Serial number
24. Power factor
25. Speed
26. Power drive system efficiency class (according to EN 50598–2)
27. Full load efficiency

3.3.2 Motor type data

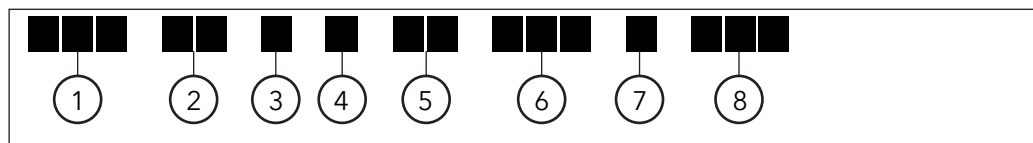

Figure 2: Motor type definition code

1	Series	ESM
2	Motor frame dimension	90R: Oversized flange 80: Standard flange
3	Shaft extension	□□: Standard shaft extension S8: Custom shaft extension

4	Power supply	1: Single phase power supply 3: Three-phase power supply
5	Shaft power · 10 [kW]	03: 0.37 kW (0.50 hp) 05: 0.55 kW (0.75 hp) 07: 0.75 kW (1.00 hp) 11: 1.10 kW (1.50 hp) 15: 1.50 kW (2.00 hp) 22: 2.20 kW (3.00 hp)
6	Motor frame arrangement	SVE: Flange with tapped holes and shaft without keyseat B14: Flange with tapped holes B5: Flange with free holes HMHA: Applicable for 1–5 e-HME monolithic pumps HMHB: Applicable for 1–5 e-HME pumps with sleeve HMVB: Applicable for 1–5 VM pumps HMHC: Applicable for 10–22 e-HME pumps HMVC: Applicable for 10–22 VM pumps LNEE: Applicable for inline pumps 56J: Compliant to NEMA 56 Jet standard 56C: Applicable to NEMA 56C standard
7	Reference market	□□: Standard EU: Standard US: North America
8	Voltage	208–240: 208–240VAC 50/60 Hz 380–460: 380–460VAC 50/60 Hz 230/400: 208–240/380–460 VAC 50/60 Hz

3.4 Design and layout

The unit can be fitted with the features required by the application.

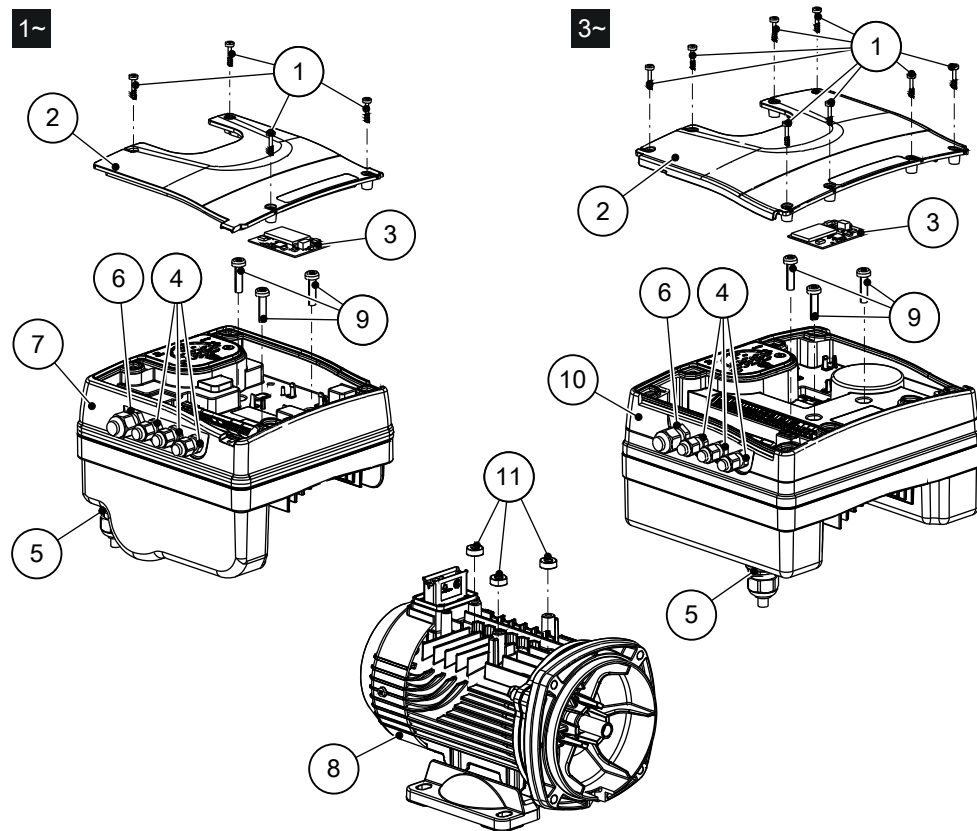

Figure 3: Main components

Table 1: Description of components

Position number	Description	Tightening torque $\pm 15\%$	
		[Nm]	[in•lbs]
1	Screw	1.4	12.4
2	Terminal box cover	—	—
3	Optional module with strip	—	—
4	M12 I/O cable gland	2.0	17.7
5	M20 cable gland for power supply cables	2.7	23.9
6	M16 I/O cable guard	2.8	24.8
7	Drive (single-phase model)	—	—
8	Motor	—	—
9	Screw	6.0	53.1
10	Drive (three-phase model)	-	—
11	Spacer	—	—

Pre-assembled factory components

Component	Version	Quantity	Notes	
Plug for cable gland	M12	3		
	M16	1		
	M20	1		
Cable gland and lock nut	M12	3	Cable out diameter	0.145–0.275 in (3.7 to 7.0 mm)
	M16	1		0.177–0.394 in (4.5 to 10.0 mm)
Cable gland	M20	1		0.265–0.512 in (7.0 to 13.0 mm)

Optional components

Table 2: Optional components

Component	Description
Sensors	The following sensors can be used with the unit: • Level-sensor
RS-485 Module	For the connection of a multi-pump system to a supervision system, via cable (Modbus or BACnet MS/TP protocol)
Adaptor	M20 Metric to 1/2" NPT Adaptor (item is always supplied for US market)

3.5 Nomenclature

Example Product Code

The various versions of the e-90E line are identified by a product code number on the pump label. This number is also the catalog number for the pump. The meaning of each digit in the product code number is shown below. Note: Not all combinations are possible.

90EBF 01 P 50 C 4 N M 0

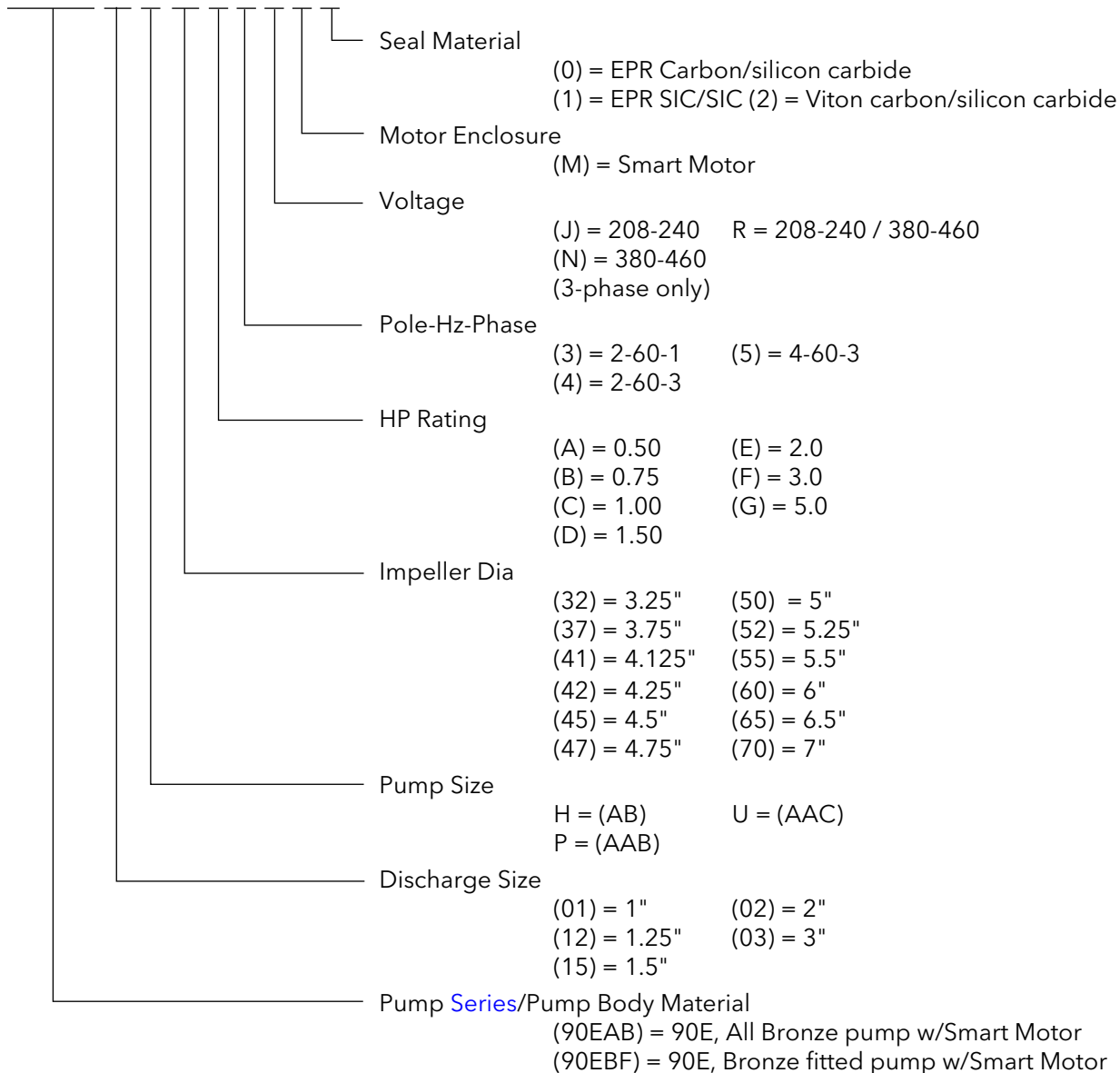

4 Installation

4.1 Preinstallation

Precautions



WARNING:

- When installing in a potentially explosive environment, make sure that the motor is properly certified.
- You must ground (earth) all electrical equipment. This applies to the pump equipment, the driver, and any monitoring equipment. Test the ground (earth) lead to verify that it is connected correctly.

NOTICE:

Supervision by an authorized Xylem representative is recommended to ensure proper installation. Failure to do so may result in equipment damage or decreased performance.

4.1.1 Pump location guidelines



WARNING:

Assembled units and their components are heavy. Failure to properly lift and support this equipment can result in serious physical injury and/or equipment damage. Lift equipment only at the specifically identified lifting points. Lifting devices such as eyebolts, slings, and spreaders must be rated, selected, and used for the entire load being lifted.



CAUTION:

CAUTION: PROPERTY DAMAGE HAZARD. It is not advisable to install circulators in an attic or upper floor over finished living space. If the circulator must be installed over head, or over expensive equipment, provide adequate drainage in the event of leakage. Failure to follow these instructions could result in property damage.

Guideline	Explanation/comment
Keep the pump as close to the liquid source as practically possible.	This minimizes the friction loss and keeps the suction piping as short as possible.
Make sure that the space around the pump is sufficient.	This facilitates ventilation, inspection, maintenance, and service.
If you require lifting equipment such as a hoist or tackle, make sure that there is enough space above the pump.	This makes it easier to properly use the lifting equipment and safely remove and relocate the components to a safe location.
Protect the unit from weather and water damage due to rain, flooding, and freezing temperatures.	This is applicable if nothing else is specified.
Do not install and operate the equipment in closed systems unless the system is constructed with properly-sized safety devices and control devices.	Acceptable devices: <ul style="list-style-type: none"> • Pressure relief valves • Expansion tanks • Pressure controls • Temperature controls • Flow controls If the system does not include these devices, consult the engineer or architect in charge before you operate the pump.

Guideline	Explanation/comment
Take into consideration the occurrence of unwanted noise and vibration.	Vibration can be transmitted to the piping system, which can result in objectionable noise away from the pump.
If the pump location is overhead, undertake special precautions to reduce possible noise transmission.	Consider a consultation with a noise specialist.
When possible, locate the pump below the fluid level.	This facilitates priming, ensures a steady flow of liquid, and provides a positive suction head on the pump.

Mode of discharge

You can install this pump to discharge either vertically or horizontally. The arrow on the pump body must point in the direction of the flow.

You can install the pump with the motor either vertical or horizontal. Do not install the motor below the pump body.

4.1.2 Unit installation

- Position the unit as shown in Figure 3.
- Install the unit according to the liquid flow of the system.
- The arrows on the pump body indicate the flow and the rotation direction.
- The standard rotation direction is clockwise (looking at the fan cover).
- Always install a backflow-prevention device on the suction side.
- Always install the pressure sensor on the delivery side, after the check valve.

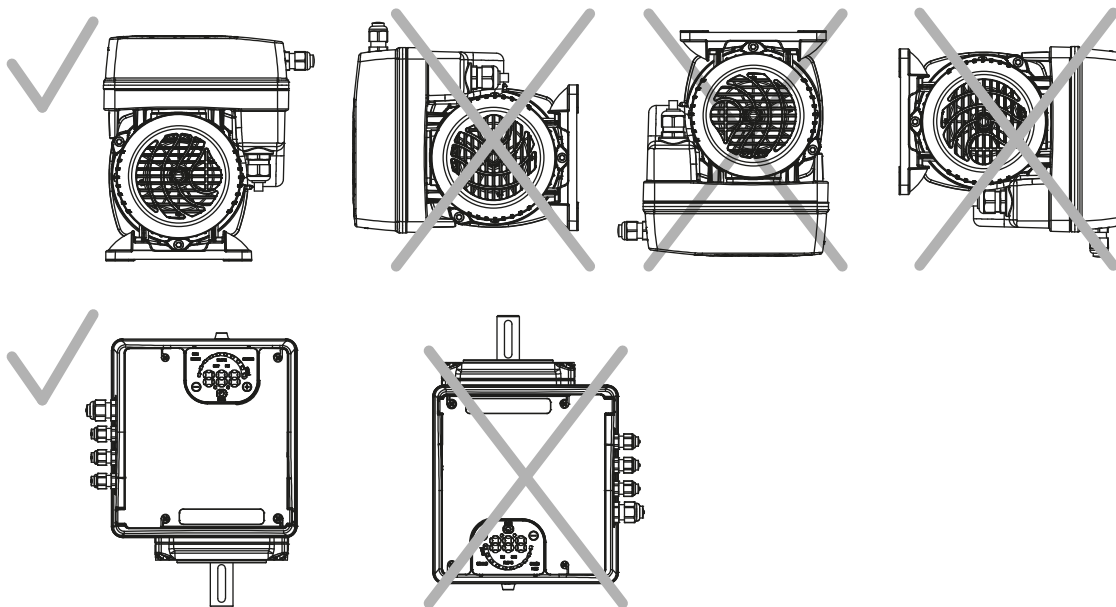

Figure 4: Permitted positions

Minimum spacing

Area	e-SM Drive model	Free distance
Above the unit	103..105..107..111..115	> 10.2 in (260 mm)
Center-distance between units (to ensure space for cabling)	103..105..107..111..115	> 10.2 in (260 mm)
	303..305..307..311..315..322	≥ 11.8 in (300 mm)

4.1.3 Piping checklist

**WARNING:**

- The heating of water and other fluids causes volumetric expansion. The associated forces can cause the failure of system components and the release of high-temperature fluids. In order to prevent this, install properly sized and located compression tanks and pressure-relief valves. Failure to follow these instructions can result in serious personal injury or death, or property damage.
- Avoid serious personal injury and property damage. Make sure that the flange bolts are adequately torqued.

NOTICE:

Never force piping to make a connection with a pump.

Check	Explanation/comment	Checked
Check that a section of straight pipe, with a length that is five times its diameter, is installed between the suction side of the pump and the first elbow, or that a B&G Suction Diffuser is installed.	This reduces suction turbulence by straightening the flow of liquid before it enters the pump.	
Check that the suction and discharge pipes are supported independently by use of pipe hangers near the pump.	This eliminates pipe strain on the pump.	
Check that there is a strong, rigid support for the suction and discharge lines.	As a rule, ordinary wire or band hangers are not adequate to maintain proper alignment.	
For pumps with flanges, check that the bolt holes in the pump flanges match the bolt holes in the pipe flanges.	—	
Check that the suction or discharge lines are not forced into position.	Bearing wear will result if suction or discharge lines are forced into position.	
Check that fittings for absorbing expansion are installed in the system when considerable temperature changes are expected.	This helps to avoid strain on the pump.	
Check that you have a foot valve of equal or greater area than the pump suction piping when you use in an open system with a suction lift.	Prevent clogging by using a strainer at the suction inlet next to the foot valve. Make sure that the strainer has an area three times that of the suction pipe with a mesh hole diameter of no less than 0.25 in. (0.64 cm).	
Check that a B&G Triple Duty® valve is installed in the discharge line.	This valve serves as a check valve that protects the pump from water hammer, and serves as an isolation valve for servicing and for throttling.	
Check that the pipeline has isolation valves around the pump and has a drain valve in the suction pipe.	—	
Use PTFE tape sealer or a high quality thread sealant when you install the suction and discharge connections to a threaded pump housing.	—	
On an open system, check that the end of the suction pipe is at least 3 ft. below the surface of the water in the suction well.	This prevents air from being drawn into the pump. Avoid air pockets in the suction line and make sure that each section of the suction pipe is air tight.	

Check	Explanation/comment	Checked
Check that new flange gaskets are installed between the flanges of the pump body suction and discharge pipes. Make sure that these gaskets are clean and grease-free.	Suitable fasteners for this connection are supplied in the Xylem fastener pack. Apply a torque of 8 to 11 ft. lbs (11 to 15 Nm) to each of the flange bolts.	

4.1.4 Typical installation

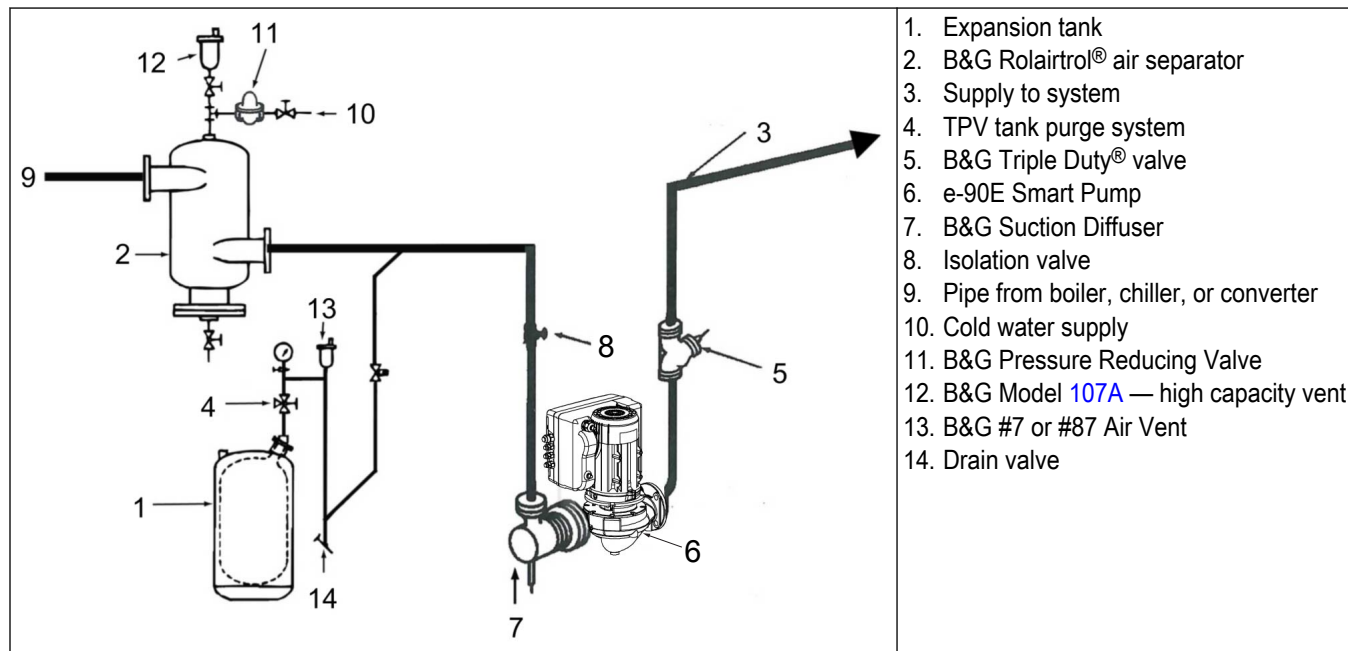

When installing and operating the [Series e-90](#) pump in closed systems, B&G recommends the use of the following safety & control devices.

- Pressure relief valves
- Expansion tanks
- Pressure controlling equipment
- Temperature controlling equipment
- Flow controlling equipment

Check that the control and safety devices have these characteristics:

- Properly sized for their purpose
- Placed correctly in the system before putting the system into operation

4.2 Electrical installation



Electrical Hazard:

The connection to the electric power supply must be completed by an electrician possessing the technical-professional requirements outlined in the current regulations.

4.2.1 Electrical requirements

- The local regulations in force overrule specified requirements listed below.

Electrical connection checklist

Check that the following requirements are met:

- The electrical leads are protected from high temperature, vibrations, and collisions.
- The current type and voltage of mains connection must correspond to the specifications on the data plate on the pump.
- The supply power line is provided with:
 - A disconnect switch with a contact gap of at least 0.12 in (3 mm) must be installed between the electrical service panel and controller.

**WARNING:**

To reduce the risk of electric shock, install only on a circuit protected by a ground-fault circuit interrupter (GFCI)

The electrical control panel checklist**NOTICE:**

The electrical service panel must match the ratings of the electric pump. Inappropriate combinations do not guarantee the protection of the unit.

Check that the following requirements are met:

- The electrical service panel must protect the converter and the pump against short circuit. A time lag fuse or a circuit breaker (Type C model is suggested) can be used to protect the pump. Use only time-delay fuses to protect the pump.
- The pump has built-in overload and thermal protection. No additional overload protection is required.

**Electrical Hazard:**

Before starting work on the unit, make sure that the unit and the control panel are isolated from the power supply and cannot be energized.

Grounding (earthing)**Electrical Hazard:**

- Always connect the external protection conductor to the ground terminal before attempting to make any other electrical connections.
- Connect all the electric accessories of the pump and the motor to the ground, making sure that the connections are completed correctly.
- Check that the protection conductor (ground) is longer than the phase conductors; in case of accidental disconnection of the power supply conductor, the protection conductor (ground) must be the last one to detach itself from the terminal.

Use a cable with several strands to reduce electric noise.

4.3 Wire types and ratings

- All cables must comply with local and national standards in terms of section and ambient temperature.
- To ensure compliance with UL (Underwriters Laboratories) regulations, all power supply connections must be completed using the following types of copper cables with minimum resistance 167°F (+75°C): THW, THWN
- Cables must never enter into contact with the motor body, the pump, or the piping.
- The wires that are connected to the power supply terminals and the fault signal relay (NO, C) must be separated from the other wires by reinforced insulation.

Table 3: Electric connection cables

Smart motor models	Power supply input cable + PE		Tightening torque	
	Wire numbers x Max. copper section	Wire numbers x Max. AWG	Mains and motor cable terminals	Earth conductor
1 phase	3 x 0.0032 sq. in 3 x 2.08 mm ²	3 x 16 AWG with ferrules 14 AWG without	Spring connectors	Spring connectors
3 phase	4 x 0.0032 sq. in 4 x 2.08 mm ²	4 x 16 AWG with ferrules / 14 AWG without	7.1 lbf-in 0.8 Nm	26.6 lbf-in 3 Nm

Control cables

External volt free contacts must be suitable for switching < 10 VDC.

NOTICE:

- Install the control cables separate from the power supply cables and the fault signal relay cable
- If the control cables are installed in parallel with the power supply cable or the fault signal relay, the distance between the cables must exceed 8 in (200 mm)

Do not intersect the power supply cables; should this be necessary, a 90° intersection angle is permitted.

Table 4: Recommended control cables

Smart motor control cables	Wires number x Max. copper Section	AWG	Tightening torque
All I/O conductors	0.00012–0.0023 sq.in 0.75–1.5 mm ²	18–16 AWG	5.4 lbf-in 0.6 Nm



Electrical Hazard:

Contact with electric components may cause death, even after the unit has been switched off. Before any interventions on the unit, the network voltage and any other input voltages must be disconnected for 5 minutes.

4.4 Power supply connection



Electrical Hazard:

Contact with electric components may cause death, even after the unit has been switched off. Before any interventions on the unit, the network voltage and any other input voltages must be disconnected for 5 minutes.



CAUTION:

Once powered the system will automatically run and attempt to satisfy the 50 PSI preset value. To prevent ramp up press the power button directly after connecting power to put into standby mode.

Table 5: Power supply wiring procedure

	Reference
1. Open the terminal box cover (2) by removing the screws (1).	<i>Figure 3</i> on page 11
2. Insert the power cable in the M20 cable gland (5).	

	Reference
<ol style="list-style-type: none"> 1. Connect the cable according to the wiring diagram. 2. Connect the earth conductor (mass), making sure that it is longer than the phase conductors. 3. Connect the phase leads. 	Figure 5 on page 20
<ol style="list-style-type: none"> 1. Close the cover (2) and tighten the screws (1). 	Figure 3 on page 11

Table 6: I/O wiring procedure

	Reference
<ol style="list-style-type: none"> 1. Open the terminal box cover (2) by removing the screws (1). 	Figure 3 on page 11
<ol style="list-style-type: none"> 1. Connect the cable according to the wiring diagram. 	Figure 6 on page 21
<ol style="list-style-type: none"> 1. Close the cover (2) and tighten the screws (1). 	Figure 3 on page 11

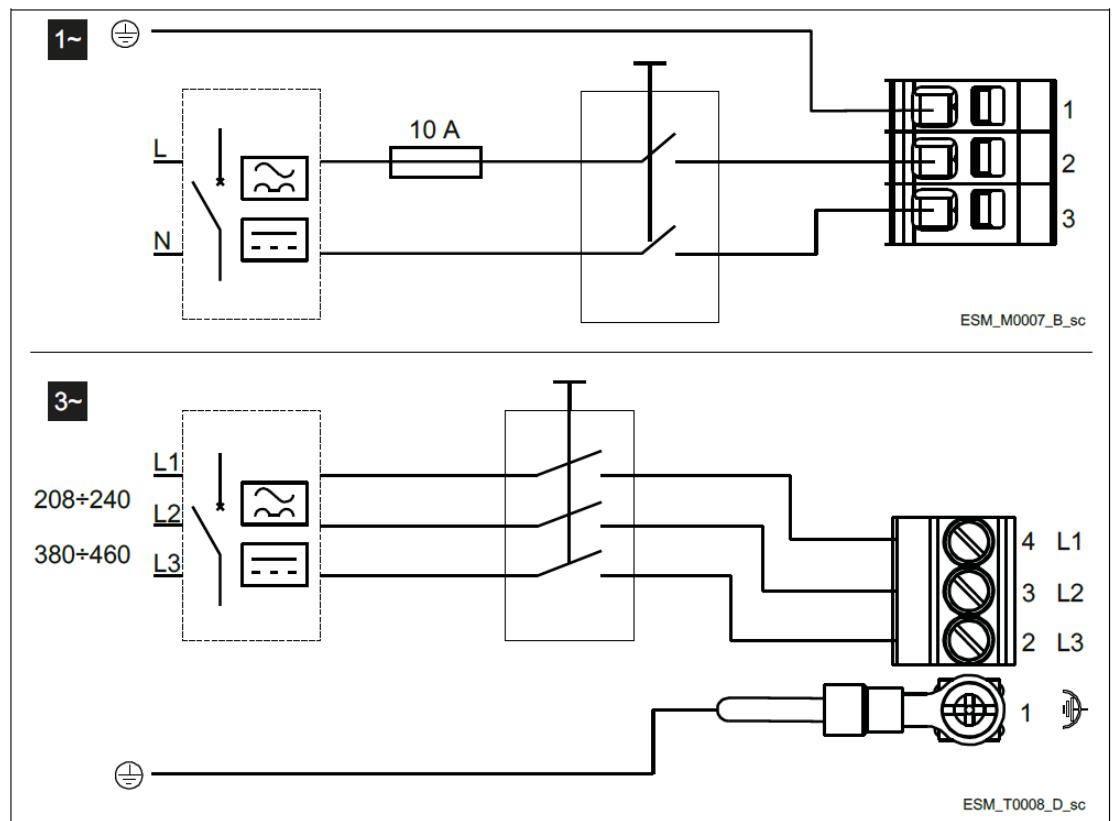

Figure 5: Wiring diagrams

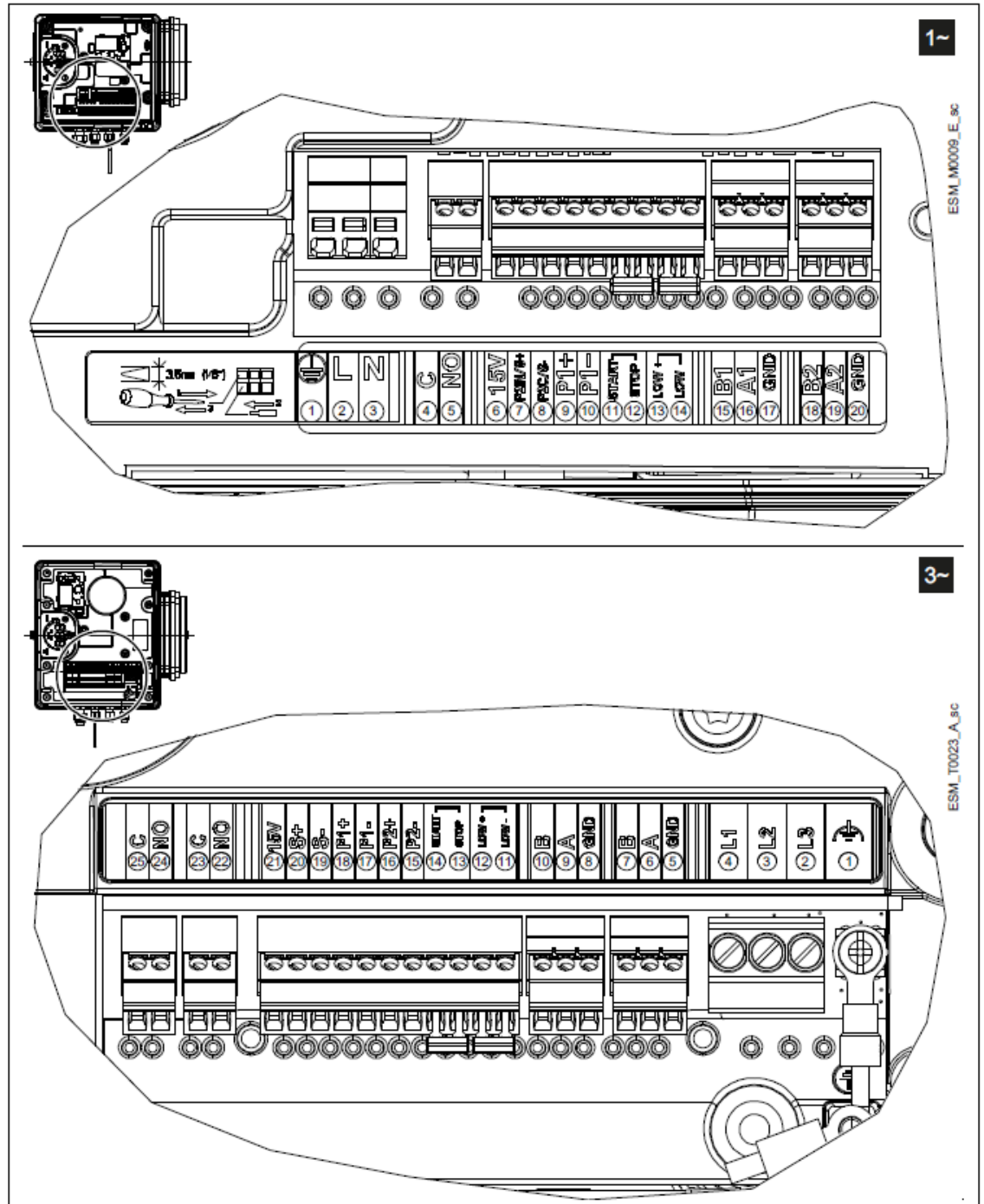

Figure 6: Connection label

Table 7: Amps

Rated output	Phase	Voltage	Rated input current
2 hp	1	208–240	7.25–8.42 A
2 hp	3	208–240	6.08–6.69 A
3 hp	3	380–460	5.24–5.93 A

Table 8: 1~ I/O terminals

Item	Terminals	Ref.	Description	Notes
Fault signal	C	4	COM - error status relay	Closed: error Open: No error or unit off
	NO	5	NO - error status relay	
Auxiliary voltage supply	15 V	6	Auxiliary voltage supply +15 VDC	15VDC, Σ max. 100 mA
Analog input 0-10V	P2IN/S+	7	Actuator mode 0-10 V input	0-10 VDC
	P2C/S-	8	GND for 0-10 V input	GND, electronic ground (for S+)
External pressure sensor [also Differential]	P1+	9	Power supply external sensor +15 VDC	15 VDC, Σ max. 100 mA
	P1-	10	External sensor 4-20 mA input	4-20 mA
External Start/Stop	START	11	External ON/OFF input reference	Default short circuited Pump is enabled to RUN
	STOP	12	External ON/OFF input	
External Lack of Water	LOW+	13	Low water input	Default short circuited Lack of water detection: enabled
	LOW-	14	Low water reference	
Communication bus	B1	15	RS-485 port 1: RS-485-1N B (-)	ACT, HCS control mode: RS-485 port1 for external communication MSE, MSY control mode: RS-485 port 1 for multi-pump systems
	A1	16	RS-485 port 1: RS-485-1P A (+)	
	GND	17	Electronic GND	
Communication bus	B2	18	RS-485 port 2: RS-485 port 2: RS-485-2N B (-) active only with optional module	RS-485 port2 for external communication
	A2	19	RS-485 port 2: RS-485 port 2: RS-485-2P A (+) active only with optional module	
	GND	20	Electronic GND	

Table 9: 3~ I/O terminals

Item	Terminals	Ref.	Description	Notes
Fault signal	C	25	COM - error status relay	In case of power cables: use the M20 cable gland
	NO	24	NO - error status relay	
Motor running signal	C	23	Common contact	In case of power cables: use the M20 cable gland
	NO	22	Normally open contact	

Item	Terminals	Ref.	Description	Notes
Auxiliary voltage supply	15 V	21	Auxiliary voltage supply +15 VDC	15 VDC, Σ max. 100 mA
Analog input 0-10V	S+	20	Actuator mode 0–10 V input	0–10 VDC
	S-	19	GND for 0-10 V input	GND, electronic ground (for S+)
External pressure sensor [also Differential]	P1+	18	Power supply external sensor +15 VDC	15 VDC, Σ max. 100 mA
	P1-	17	External sensor 4-20 mA input	4-20 mA
External pressure sensor	P2+	16	Power supply external sensor +15 VDC	15 VDC, Σ max. 100 mA
	P2-	15	Sensor 4-20 mA input	4-20 mA
External Start/Stop	Start	14	External ON/OFF input	Default short circuited Pump is enabled to RUN
	Stop	13	External ON/OFF input reference	
External Lack of Water	LoW+	12	Low water input	Default short circuited Lack of water detection: enabled
	LoW-	11	Low water reference	
Communication Bus	B2	10	RS-485 port 2: RS-485-2N B (-) active only with optional module	RS-485 port2 for external communication
	A2	9	RS-485 port 2: RS-485-2P A (+) active only with optional module	
	GND	8	Electronic GND	
Communication Bus	B1	7	RS-485 port 1: RS-485-1N B (-)	ACT, HCS control mode: RS-485 port 1 for external communication Control mode MSE, MSY: RS-485 port 1 for multi-pump systems
	A1	6	RS-485 port 1: RS-485-1P A (+)	
	GND	5	Electronic GND	

5 Commissioning, Startup, Operation, and Shutdown

5.1 Preparation for startup



WARNING:

- Failure to follow these precautions before you start the unit will lead to serious personal injury and equipment failure.
- Do not operate the pump below the minimum rated flows or with the suction or discharge valves closed. These conditions can create an explosive hazard due to vaporization of pumped fluid and can quickly lead to pump failure and physical injury.
- If the pump, motor, or piping operate at extremely high or low temperatures, then guarding or insulation is required. Failure to follow these instructions can result in serious personal injury or death, and property damage.
- Always disconnect and lock out power to the driver before you perform any installation or maintenance tasks. Failure to disconnect and lock out driver power will result in serious physical injury.
- Operating the pump in reverse rotation can result in the contact of metal parts, heat generation, and breach of containment.

NOTICE:

- Verify the driver settings before you start any pump.
- Make sure that the warm-up rate does not exceed 2.5°F (1.4°C) per minute.

You must follow these precautions before you start the pump:

- Flush and clear the system thoroughly to remove dirt or debris in the pipe system in order to prevent premature failure at initial startup.
- Bring variable-speed drivers to the rated speed as quickly as possible.
- If temperatures of the pumped fluid will exceed 200°F (93°C), then warm up the pump prior to operation. Circulate a small amount of fluid through the pump until the casing temperature is within 100°F (38°C) of the fluid temperature.

At initial startup, do not adjust the variable-speed drivers or check for speed governor or over-speed trip settings while the variable-speed driver is coupled to the pump. If the settings have not been verified, then uncouple the unit and refer to instructions supplied by the driver manufacturer.

5.1.1 Check the rotation



WARNING:

- Operating the pump in reverse rotation can result in the contact of metal parts, heat generation, and breach of containment.
- Always disconnect and lock out power to the driver before you perform any installation or maintenance tasks. Failure to disconnect and lock out driver power will result in serious physical injury.

-
1. Unlock power to the driver.
 2. Make sure that everyone is clear, and then jog the driver long enough to determine that the direction of rotation corresponds to the arrow on the pump.
Pump rotation is clockwise when viewed from the back of the motor. An arrow is provided to show rotational direction.
 3. Lock out power to the driver.

5.2 Lubrication requirements

These pumps are permanently lubricated.

5.3 Wait times



Electrical Hazard:

Contact with electric components may cause death, even after the unit has been switched off. Before any interventions on the unit, the network voltage and any other input voltages must be disconnected for five minutes.

Model	Minimum wait time
103, 105, 197, 111, 115	4
303, 305, 307, 311, 315, 322	5

5.4 System setup and operation

5.4.1 Programming precautions

NOTICE:

- Carefully read and adhere to the following instructions before starting the programming activities to avoid incorrect settings that can cause malfunctions.
- All modifications must be done by qualified technicians.

5.4.2 Control panel description

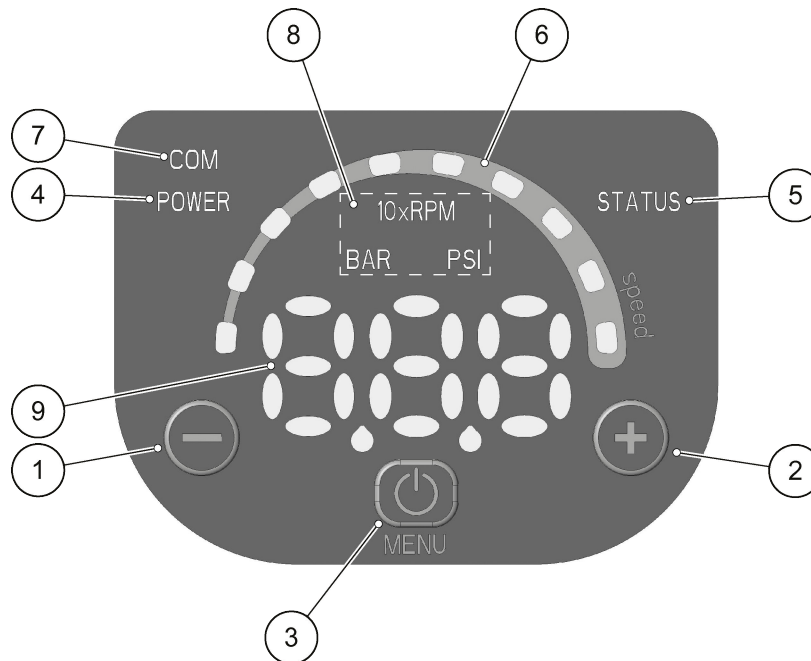









Figure 7: Control panel

Position number	Description	Parameter
1	Decrease button	6.2
2	Increase button	6.2
3	START/STOP and menu access button	6.2
4	POWER LED	6.3.1

Position number	Description	Parameter
5	Status LED	6.3.2
6	Speed LED bar	6.3.3
7	Communication LED	6.3.4
8	Unit of measure LEDs	6.3.5
9	Display	6.4

5.4.3 Push button descriptions

Refer to [Control panel description](#) on page 25 for the location of the push buttons.

Push button	Function
	<ul style="list-style-type: none"> Main view (see parameter 6.4.1): decreases the required value for the selected control mode Parameter menu (see parameter 6.4.2): decreases the displayed parameter index Parameter view / editing (see parameter 6.4.2): decreases the value of the displayed parameter Zero pressure auto-calibration (see parameter 6.5, P44): automatic calibration of the pressure sensor.
	<ul style="list-style-type: none"> Main view (see parameter 6.4.1): increases the required value for the selected control mode Parameter menu (see parameter 6.4.2): increases the displayed parameter index Parameter view / editing (see parameter 6.4.2): increases the value of the displayed parameter Zero pressure auto-calibration (see parameter 6.5, P44): automatic calibration of the pressure sensor.
	<ul style="list-style-type: none"> Main view (see parameter 6.4.1): START/STOP the pump Parameter menu (see parameter 6.4.2): switches to parameter view / editing Parameter view / editing (see parameter 6.4.2): saves the value of the parameter.
 long press	<ul style="list-style-type: none"> Main view (see parameter 6.4.2): switches to parameter selection Parameters Menu: switches to Main Visualization
 and 	Main view: alternates between Speed and Head units of measure (see parameter 6.4.1).
 and 	Main view: alternates between Speed and Head units of measure (see parameter 6.4.1).

5.4.4 LED description

5.4.4.1 POWER (power supply)

When ON (POWER) the pump is powered and the electronic devices are operational.

5.4.4.2 STATUS

LED	Status
Off	Pump unit stopped
Green steady	Pump unit in operation
Flashing green and orange	Non-locking alarm with the pump unit in operation

LED	Status
Orange steady	Non-locking alarm with the pump unit stopped
Red steady	Locking error, the pump unit cannot be started

5.4.4.3 SPEED (speed bar)

The speed bar consists of 10 LEDs, each representing the speed range between parameter P27 (minimum speed) and parameter P26 (maximum speed) from 0-100% in intervals of 10%.

LED bar	Status
On	Motor in operation; the speed corresponds to the percentage step represented by the LEDs ON in the bar (for example, 3 LEDs ON = speed 30%)
First LED flashing	Motor in operation; the speed is lower than the absolute minimum, P27
Off	Motor stopped

5.4.4.4 COM (communication)

Condition 1

- The communication bus protocol is the Modbus RTU protocol; the P50 parameter is set to the Modbus value
- No optional communication module is used.

LED	Status
Off	The unit cannot detect any valid Modbus messages on the terminals provided for the communication bus
Green steady	The unit has detected a communication bus on the provided terminals and has recognized the correct addressing.
Green flashing	The unit has detected a communication bus on the provided terminals and has not been addressed correctly
From green steady to off	The unit has not detected a valid Modbus RTU message for at least 5 seconds.
From green steady to flashing	The unit has not been addressed correctly for at least 5 seconds.

Condition 2

- The communication bus protocol is the BACnet MS/TP protocol; the P50 parameter is set to the BACnet value
- No optional communication module is used.

LED	Status
Off	The unit has received no valid requests from other BACnet MS/TP devices for at least 5 seconds.
On steady	The unit is exchanging information with another BACnet MS/TP device.

Condition 3

- A multi-pump control mode is selected (e.g. MSE or MSY)
- No optional communication module is used.

LED	Status
Off	The unit has received no valid requests from other pumps through the multi-pump BUS for at least 5 seconds
On steady	The unit is exchanging information with another pump through the multi-pump BUS.

Condition 4

The optional communication module is being used.



LED	Status
Off	RS-485 or wireless connection faulty or missing.
Flashing	The unit is exchanging information with the communication module.

















5.4.4.5 Units of measurement

LED on	Measurement active	Notes
10xRPM	Impeller rotation speed	The display shows the speed in 10xRPM
BAR	Hydraulic head	The display shows the value of the head in bar
PSI		The display shows the value of the head in psi

5.4.5 Display

5.4.5.1 Main Visualization







Display	Mode	Description
OFF	OFF	Contacts 11 and 12 (see parameter 5.4) are not short-circuited. Note: It has lower display priority than STOP mode.
STP	STOP	<p>Pump stopped manually.</p> <p>If the pump is switched on after setting P04 = OFF (see Par. 6.5.1), it is stopped so that the motor is not in operation, and STP flashes (STP → STP).</p> <p>To manually stop the pump:</p> <ul style="list-style-type: none"> • Example A: <ul style="list-style-type: none"> – HCS, MES, MSY control modes with initial required value (head) of 4.20 bar and minimum value 0.5 bar: 4.20 BAR →  press → STP once. • Example B: <ul style="list-style-type: none"> – ACT control mode with initial required value (speed) of 200 10xRPM and minimum value 80 10xRPM: 200 10xRPM →  press → STP once.

Display	Mode	Description
ON	ON	<p>Pump on; the motor starts following the selected control mode.</p> <p>It appears for a few seconds when contacts 11 and 12 (see Par. 5.4) are short circuited and the pump is not in STOP mode.</p> <p>To manually set the pump to ON mode:</p> <ul style="list-style-type: none"> • Example A: <ul style="list-style-type: none"> – HCS, MES, MSY control modes that reach a required value (head) of 4.20 bar, starting with a minimum value of 0.5 bar after manual stop: STP →  press → ON → once after a few seconds... → 4.20 BAR. • Example B: <ul style="list-style-type: none"> – ACT control mode that reaches a requested value (speed) of 200 10xRPM, starting with a minimum value of 80 10xRPM after manual stop: STP →  press → ON → once, and after a few seconds... → 200 10xRPM. <p>With the pump in operation, it is possible to display the Actual Head and the Actual Speed:</p> <ul style="list-style-type: none"> • Example A: <ul style="list-style-type: none"> – HCS, MES, MSY control modes with Actual Head 4.20 bar and corresponding Actual Speed of 352 10xRPM: 4.20 BAR →  +  → 352 10XRPM → after 10 seconds or  +  → 4.20 BAR. • Example B: <ul style="list-style-type: none"> – ACT control mode with Actual Speed 200 10xRPM and corresponding Actual Head of 2.37 bar: 200 10xRPM →  +  → 2.37 BAR → after 10 seconds or  +  → 200 10xRPM.
sby	Stand-by	<p>The analog input is configured as speed set (P40 = ISP or USP), the read value is in the Stand-by zone and P34 = STP (see paragraph 6.6.1)</p> <p>Note: It has lower display priority that STOP mode</p>
-0-	Lock	<p>To lock press  +  for 3 seconds; the lock will be confirmed by the temporary appearance of -0-</p> <p>It appears is a button is pressed (with the exception of ) after a locking procedure had been completed.</p> <p>Note: the function connected with START/STOP  is always disabled. At startup the buttons are locked, if they were locked at the previous switch off</p> <p>Default: unlocked</p>
()	Unblock	<p>To unlock press  +  for three seconds; the unlock will be confirmed by the temporary appearance of ()</p> <p>Note: At startup the buttons are unlocked. if they were unlocked at the previous switch off</p> <p>Default: unlocked</p>

5.4.5.2 Parameters menu visualization

The parameter menu gives the possibility to:

- select all the parameters (see Par. 6.5)
- access Parameter View / Editing (see Par. 6.2).



Parameter	Description
Power on	If after switching ON, parameter Menu View is accessed with P23 = ON, P20 flashes: P20 → P20. Enter the password to display and change the parameters.
Password timeout	If with P23 = ON no button is pressed for over 10 minutes from the last parameter Menu View, both the view and the editing of the parameters are disabled. Enter the password again to display and change the parameters.
Parameters Menu	With P23 = OFF, or after entering the password (P20), it is possible to both display and edit the parameters. When accessing the Parameter Menu, the display shows: P01 → P01 P02 → P02 ... P69 → P69 The flashing parameter, indicating the selection possibility.
Parameters Editing/ Visualization	The value of a parameter may be changed using the buttons, or the Modbus and BACnet communication protocols. When returning to the Parameter Menu, the displayed parameter index is increased automatically. For further information see Par. 6.5. • Example A (P20) from 000 to 066: P20 → P20 →  → 000 → 000 →  ... until ... → 066 → 066 →  sets the desired value → P21 → P21 • Example 2 (P26) from 360 to 300: P26 → P26 →  → 360 → 360 →  ... until... → 300 → 300 →  sets the desired value → → P26 → P26.

5.4.5.3 Alarms and errors visualization





Parameter	Description
Alarm	In case of alarm, the corresponding code appears on the display in alternation to the Main View. For example: A01 → 3.56 (ex. BAR) A02 → 285 (ex. 10xRPM) ...
Error	In case of error, the corresponding identification code appears on the display. For example: E01 E02 ...













5.4.6 Software parameters

Mark	Parameter type
No mark	Applicable to all units.

Mark	Parameter type
	Global parameter, shared by all pumps in the same multi-pump system
	Read only

5.4.6.1 Status parameters

Parameter number	Parameter name	Unit of measurement	Description
P01	Required value 	bar/psi/ rpmx10	This parameter shows the SOURCE and the VALUE of the active required value. Visualization cycles between SOURCE and VALUE occur every 3 seconds. SOURCES: <ul style="list-style-type: none"> • SP (SP): internal required value Setpoint related to the control mode selected. • VL (UL): external required value speed Setpoint related to 0-10V input. VALUE can represent a Speed or a Head, depending on the selected control mode: in case of Head, the unit of measure is defined by parameter P41.
P02	Effective Required Value 	bar/psi	Active required value calculated based on parameters P58 and P59. This parameter is effective only in control modes MSE or MSY. For further information on the calculation of P02, see Par. 6.6.3.
P03	Regulation Restart Value [0-100] 	%	It defines the start value after the stop of the pump, as a percentage of the P01 value. If the required value is met and there is no further consumption, then the pump stops. The pump starts again when the pressure drops below P03. P03 is valid when: <ul style="list-style-type: none"> • Different from 100% (100%=off) • The control mode is HCS, MSE or MSY. Default: 100%.
P04	Auto-start [OFF-ON] 		If P04 = ON, then the pump starts automatically following a power supply disconnection. If the pump is switched on after setting P04 = OFF (see Par. 6.5.1), it is stopped so that the motor is not in operation, and STP flashes (STP → STP). Default: ON.
P05	Operating time months 		Total months of connection to the electric mains, to add to P06.

Parameter number	Parameter name	Unit of measurement	Description
P06	Operating time hours 	h	Total hours of connection to the electric mains, to add to P05.
P07	Motor Time Months 		This parameter shows the total operating time months, to be added to P08.
P08	Motor time hours 	h	This parameter shows the total operating time hours, to be added to P07.
P09	1st error 		This parameter stores the last error occurred in chronological order. The information displayed switches through the values: <ul style="list-style-type: none"> • (Exx): xx indicates the error code • (Hyy): yy is the value of hours referred to P05-P06 when the error Exx happened • (Dww): ww is the value of days referred to P05-P06 when the error Exx happened • (Uzz): zz is the value of weeks referred to P05-P06 when the error Exx happened Example of visualisation: E04 → K10 → d03 → U15
P10	2nd error 		Saves the penultimate error in chronological occurred. Other characteristics: like P09.
P11	3rd error 		Saves the third from the last error in chronological occurred. Other characteristics: like P09.
P12	4th error 		Saves the fourth from the last error in chronological occurred. Other characteristics: like P09.
P13	Power Module Temperature 	°C	Temperature of the power module.
P14	Inverter Current 	A	This parameter shows the actual current supplied by the frequency converter.
P15	Inverter Voltage 	V	This parameter shows the actual estimated input voltage of the frequency converter.
P16	Motor Speed 	rpmx10	This parameter shows the actual motor rotational speed.
P17	Software version 		This parameter shows the Control Board software version.

5.4.6.2 Settings parameters

Parameter number	Parameter name	Description
P20	Password entering [0-999]	The user can enter here the system password, which gives access to all system parameters: this value is compared with the one stored in P22. When a correct password is entered, the system remains unlocked for 10 minutes.
P21	Jog mode [MIN-MAX]	It deactivates the internal controller of the unit and forces the actual Control Mode (ACT): the motor starts and the value of P21 becomes the temporary ACT setpoint. It can be changed by just entering a new value on P21 without confirming it; otherwise, it causes immediate exit from temporary control.
P22	System password [1-999]	This is the system password, and must be the same as the password entered in P20. Default: 66.
P23	Lock Function [OFF, ON]	By using this function, the user can lock or unlock parameter setting in the main menu. When ON, enter the P20 password to change the parameters. Default: ON.







5.4.6.3 Drive configuration parameters

Parameter number	Parameter name	Unit of measurement	Description
P25	Control mode [ACT, HCS, MSE, MSY]		<p>This parameter sets the Control Mode (default value: HCS)</p> <p>ACT: Actuator mode.</p> <ul style="list-style-type: none"> A single pump maintains a fixed speed at any flow rate. ACT will always try to minimize the difference between the speed setpoint and the actual rotational speed of the motor. If a 0-10V signal is supplied to terminals 7 and 8, the pump automatically switches to ACT mode, following the external signal. If the external signal is missing, the pump remains in ACT mode, using the value set as setpoint using the display. <p>HCS: Hydrovar® Controller mode for Single pump.</p> <ul style="list-style-type: none"> The pump maintains a constant pressure at any flow rate: the Hydrovar® algorithm, based on the set of parameters from P26 to P37 (see Par. 6.6.3), is implemented. HCS mode must be set in conjunction with the use of an absolute reading pressure sensor installed in the hydraulic circuit, which supplies the pressure feedback signal: HCS will always try to minimize the difference between the pressure setpoint and the pressure feedback signal. <p>MSE: Hydrovar® Controller mode for multiple pumps in Serial Cascade.</p> <ul style="list-style-type: none"> Pumps are managed in series: only the last activated pump modulates the speed to maintain the set pressure, while all the others in operation rotate at the maximum speed. The set of pumps, connected to each other through the multi-pump protocol, maintains a constant pressure at any flow rate: the Hydrovar® algorithm, based on the set of parameters from P26 to P37 (see Par. 6.6.3), is implemented. MSE mode must be set in conjunction with the use of absolute reading pressure sensors, one for each pump, which supply to the set the pressure feedback signal: MSE will always try to minimize the difference between the pressure setpoint and the pressure feedback signal. Using the multi-pump protocol, it is possible to connect up to 3 pumps, all of the same type and with the same power. <p>MSY: Hydrovar® Controller mode for Multiple pumps in Synchronous Cascade.</p> <ul style="list-style-type: none"> The pumps are synchronised: they all keep the set pressure and operate at the same speed. Other characteristics: as for MSE mode.
P26	Max RPM set [ACT set-Max*] G	rpmx10	Maximum pump speed setup.

Parameter number	Parameter name	Unit of measurement	Description
P27	Min RPM set [Min*-ACT set] G	rpmx10	Minimum pump speed setup.
P28	Ramp 1 [1-250] G	s	This parameter adjusts the fast acceleration time. It affects the control of the pump for HCS, MSE and MSY control modes (also see Par. 6.6.2). Default: 3 s.
P29	Ramp 2 [1-250] G	s	This parameter adjusts the fast deceleration time. It affects the control of the pump for HCS, MSE and MSY control modes (also see Par. 6.6.2). Default: 3 s.
P30	Ramp 3 [1-999] G	s	This parameter adjusts the slow acceleration. It determines: <ul style="list-style-type: none"> • The Hydrovar® adjustment speed, in case of small flow rate variations • The constant outgoing pressure. The ramp depends on the system being controlled, and affects the control of the pump in HCS, MSE and MSY modes (also see Par. 6.6.2). Default: 35 s.
P31	Ramp 4 [1-999] G	s	Adjustment of the slow deceleration time (also see Par. 6.6.2). Other characteristics: as for Ramp 3.
P32	Ramp Speed Min Acceleration [2.0-25.0] G	s	This parameter sets the fast acceleration time. It represents the acceleration ramp used by the Hydrovar® controller until the minimum speed of the pump is reached (P27). It affects the control of the pump for HCS, MSE and MSY control modes (also see Par. 6.6.2). Default: 2.0 s.
P33	Ramp Speed Min Deceleration [2.0-25.0] G	s	This parameter sets the fast deceleration time. It represents the deceleration ramp used by the Hydrovar® controller for stopping the pump once the minimum speed of the pump is reached (P27). It affects the control of the pump for HCS, MSE and MSY control modes (also see Par. 6.6.2). Default: 2.0 s.

Parameter number	Parameter name	Unit of measurement	Description
P34	Speed Min Configuration [STP, SMI] G		<p>This parameter defines the operation of the Hydrovar® controller once the minimum speed of the pump is reached (P27):</p> <ul style="list-style-type: none"> • STP (STP): once the required pressure is reached and no further request is made, the pump speed decreases to the selected P27 value: Hydrovar® then keeps running for the selected time interval (P35), and then stops automatically. • SNI (SMI): once the required pressure is reached and no further request is made, the pump speed decreases to the selected P27 value: Hydrovar® continues running at the same speed. This parameter affects the control of the pump for HCS, MSE and MSY control modes. <p>Default: STP</p>
P35	Smin time [0-100] G	s	<p>This parameter sets the time delay before a shut-off below P27 occurs.</p> <p>It is only used by the Hydrovar® controller if P34 = STP.</p> <p>It affects the control of the pump for HCS, MSE and MSY control modes.</p> <p>Default: 0 s.</p>
P36	Window [0-100] G	%	<p>This parameter sets the ramp control interval, as a percentage of the pressure setpoint.</p> <p>It is used to define the range of pressures, around the setpoint, in which the Hydrovar® controller uses slow acceleration and deceleration ramps instead of fast ones.</p> <p>It affects the control of the pump for HCS, MSE and MSY control modes (also see Par. 6.6.2).</p> <p>Default: 10%.</p>
P37	Hysteresis [0-100] G	%	<p>This parameter sets the slow ramp hysteresis, as a percentage of P36.</p> <p>It helps define the pressure range, around the setpoint, in which Hydrovar® goes from slow acceleration ramp (P28) to slow deceleration ramp (P29).</p> <p>The parameter affects the control of the pump for HCS, MSE and MSY control modes (also see Par. 6.6.2).</p> <p>Default: 80%.</p>
P38	Speed Lift [0-MAX*] G	rpmx10	<p>This parameter sets the speed limit after which the linear increase of the actual require value starts (P02), until the total increase (P39) at maximum speed (P26).</p> <p>Default: P27.</p>
P39	Lift Amount [0-200] G	%	<p>This parameter sets the increase value of the actual required value (P02) at the maximum speed (P26), measured as a percentage of the required value (P01).</p> <p>It determines the increase of the required pressure set, useful to compensate for flow resistances at high flow rates.</p> <p>Default: 0.</p>

5.4.6.4 Sensor configuration parameters

Parameter number	Parameter name	Unit of measurement	Description
P40	Sensor selection [P1, ISP, USP]		Analog input configuration setup: <ul style="list-style-type: none"> • P1 absolute reading pressure sensor • ISP 4–20 mA input as speed reference • USP 0–10 V input as speed reference Default: P1
P41	Pressure Sensor Unit Of Measure [BAR, PSI] 		This parameter sets the unit of measure (BAR, PSI) for the pressure sensor. It affect the head view LED parameter (see Par. 6.3.4). Default: bar.
P42	Full scale value for pressure Sensor 1 4-20mA [0.0-25.0BAR] / [0.0-363PSI] 	bar/psi	This parameter sets the Full Scale value of the 4-20mA pressure sensor connected to analog input 17 and 18. Default: depending on the type of pump.
P44	Zero Pressure Auto-Calibration	bar/psi	This parameter lets the user perform the initial auto-calibration of the pressure sensor. It is used to compensate for the offset signal of the sensor at zero pressure caused by the tolerance of the sensor itself. Procedure: <ol style="list-style-type: none"> 1. Access P44 when the hydraulic system is at 0 pressure (no water inside), or with the pressure sensor disconnected from the piping: the actual value of 0 pressure is displayed. 2. Start the auto-calibration by pressing   or (see Par. 6.2). 3. At the end of the auto-calibration, the 0 (zero) pressure is displayed, or the “---“ (---) message, if the sensor signal is out of the permitted tolerance.
P45	Pressure Minimum Threshold [0-42] 	bar/psi	Setting the minimum pressure threshold. If the system pressure falls below this threshold for the time set in P46, a low pressure error E14 is generated. Default: 0 bar.
P46	Pressure Minimum Threshold - Delay Time [1-100] 	s	Time delay setup. This parameter sets the time delay during which the unit remains idle with a system pressure below P45, before generating the low pressure error E14. Default: 2 s.
P47	Pressure Minimum Threshold – Automatic Error Reset [OFF, ON] 		Enabling/disabling of automatic unit attempts in case of low pressure error. Default: ON.





Parameter number	Parameter name	Unit of measurement	Description
P48	Lack Of Water Switch Input [DIS, ALR, ERR]		<p>This parameter enables/disables the management of the lack of water input (see Par. 4.3.3, terminals 13 and 14).</p> <p>It defines the behaviour of the unit when the lack of water input is enabled and the switch is open:</p> <ul style="list-style-type: none"> • DIS (DIS): the unit doesn't manage the information coming from the "lack of water" input. • ALr (ALr): the unit reads the "lack of water" Input (enabled) and reacts, at the opening of the switch, by displaying the corresponding alarm A06 on the display, and keeping the motor running. • Err (Err): Err, the unit reads the Lack Of Water Input (enabled) and reacts, at the opening of the switch, by stopping the motor and generating the corresponding error E11. The error condition is removed when the switch closes again and the motor is started. <p>Default: ERR.</p>





5.4.6.5 RS-485 Interface parameters

Parameter name	Parameter number	Unit of measurement	Description
P50	Communication protocol [MOD, BAC]		<p>This parameter selects the specific protocol on the communication port:</p> <ul style="list-style-type: none"> • NOD (MOD): Modbus RTU • BAC (BAC): BACnet MS/TP. <p>Default: MOD.</p>
P51	Communication protocol - Address [1-247]/[0-127]		<p>This parameter sets the desired address for the unit, when connected to an external device, depending on the protocol selected in P50:</p> <ul style="list-style-type: none"> • MOD: any value in the 1-247 range • BAC: any value in the 0-127 range.
P52	Comm Protocol – BAUDRATE [4.8, 9.6, 14.4, 19.2, 38.4, 56.0, 57.6 KBPS]	kbps	<p>This parameter sets the desired baud rate for the communication port.</p> <p>Default: 9.6 kbps.</p>
P53	BACnet Device ID Offset [0-999]		<p>This parameter sets the hundreds, tens and units of the BACnet Device ID.</p> <p>Default: 002.</p> <p>Device ID default: 84002.</p>
P54	Comm Protocol – Configuration [8N1, 8N2, 8E1, 8o1]		<p>This parameter sets the length of the data bits, the parity and the length of the STOP bits.</p>

5.4.6.6 Multi-pump configuration parameters

All these parameters affect MSE and MSY control modes.

Parameter number	Parameter name	Unit of measurement	Description
P55	Multipump – Address [1-3]		This parameter sets the address of each pump based on the following criteria: <ul style="list-style-type: none"> • Each pump needs an individual pump address (1-3) • Each address may only be used once. Default: 1.
P56	Multipump – Max Units [1-3] 		This parameter sets the maximum number of pumps operating at the same time. Default: 3.
P57	Multipump – Switch Interval [0-250] 	h	Setpoint of the main pump forced switch interval. If the pump with priority 1 works in continuous mode until this time is reached, the switch between this pump and the next is forced. On the other hand, if the system stops completely due to the setpoint being reached, the next start priority 1 will be assigned in a way to ensure an even distribution of the operating hours of all pumps. Default: 24 h.
P58	Multipump – Actual Value Increase [0.0-25.0BAR] / [0.0-363PSI] 	bar/psi	This parameter affects the calculation of P02, to improve the Multipump control as described in paragraph 6.6.3. Default: 0.35 bar.
P59	Multipump – Actual Value Decrease [0.0-25.0BAR] / [0.0-363PSI] 	bar/psi	This parameter affects the calculation of P02, to improve the multi-pump control as described in paragraph 6.6.3. Default: 0.15 bar.

Parameter number	Parameter name	Unit of measurement	Description
P60	Multipump – Enable Speed [P27-P26] 	rpmx10	This parameter sets the speed that a pump must reach before starting the next assist pump, after a system pressure drop below the difference between P02 and P59. Default: depending on the type of pump.
P61	Multipump Synchronous – Speed Limit [P27-P26] 	rpmx10	This parameter sets the speed limit below which the first assist pump stops. Default: depending on the type of pump.
P62	Multipump Synchronous – Window [0-100] 	rpmx10	This parameter sets the speed limit for the stop of the next assist pump. Default: 150 rpmx10.
P63	Multipump – Priority 		This parameter shows the pump priority value within the multi-pump set. This parameter displays the following information: Pr1 (Pr1) .. Pr3 (Pr3) or Pr0 (Pr0) where: <ul style="list-style-type: none"> • Pr1 .. PR3, indicate that the pump is communicating with other pumps of the displayed priority order. • Pr0 indicates that the pump does not detect the communication with other pumps and is considered alone in the multi-pump bus
P64	Multipump – Revision 		This parameter shows the multi-pump protocol revision value used.

5.4.6.7 Special parameters

Parameter number	Parameter name	Unit of measurement	Description
P68	Default Values Reload [NO, rES]		If set to RES, after confirmation this parameter performs a factory reset that reloads the default parameter values.

Parameter number	Parameter name	Unit of measurement	Description
P69	Avoid Frequent Parameters Saving [NO, YES]		This parameter limits the frequency with which the unit stores the required value P02 in the EEPROM memory, in order to extend its life. This could be particularly useful in applications with BMS control devices that require continuous variation of the value for fine tuning purposes. Default: NO.

5.5 Prime the pump



CAUTION:

Do not run the pump dry.

Make sure that the pump body is full of liquid before startup. If the system does not automatically fill the pump body with liquid, then you must manually prime the pump.

1. Loosen the vent plugs on the pump body. Loosen the vent valve on the flush line assembly.
2. While venting the air from the pump body, rotate the pump shaft a few times by hand.
3. After all air has been purged from the pump, close the vent plugs.

5.6 Start the pump



WARNING:

Pressurize the pump body slowly while you check for leaks at all joints with gaskets. Failure to follow these instructions can result in serious personal injury and/or property damage.



CAUTION:

- Observe the pump for vibration levels, bearing temperature, and excessive noise. If normal levels are exceeded, shut down the pump and resolve the issue.

Before you start the pump, you must perform these tasks:

- Open the suction valve.
 - Open any recirculation or cooling lines.
1. Fully close or partially open the discharge valve, depending on system conditions.
 2. Start the motor.
 3. Slowly open the discharge valve until the pump reaches the desired flow.
 4. Immediately check the pressure gauge to ensure that the pump quickly reaches the correct discharge pressure.
 5. If the pump fails to reach the correct pressure, perform these steps:
 - a) Stop the motor.
 - b) Restart the motor.
 6. Monitor the pump while it is operating:

- a) Check the pump for bearing temperature, excessive vibration, and noise.
 - b) If the pump exceeds normal levels, then shut down the pump immediately and correct the problem.
7. Repeat steps 5 and 6 until the pump runs properly.

5.7 Pump operation precautions

General considerations



CAUTION:

- Vary the capacity with the regulating valve in the discharge line. Never throttle the flow from the suction side since this can result in decreased performance, unexpected heat generation, and equipment damage.
 - Do not overload the driver. Driver overload can result in unexpected heat generation and equipment damage. The driver can overload in these circumstances:
 - The specific gravity of the pumped fluid is greater than expected.
 - The pumped fluid exceeds the rated flow rate.
 - Make sure to operate the pump at or near the rated conditions. Failure to do so can result in pump damage from cavitation or recirculation.
-

Operation at reduced capacity



WARNING:

Never operate any pumping system with a blocked suction and discharge. Operation, even for a brief period under these conditions, can cause confined pumped fluid to overheat, which results in a violent explosion. You must take all necessary measures to avoid this condition.



CAUTION:

Avoid excessive vibration levels. Excessive vibration levels can damage the bearings, stuffing box or seal chamber, and the mechanical seal, which can result in decreased performance.

NOTICE:

- Avoid increased radial load. Failure to do so can cause stress on the shaft and bearings.
 - Avoid heat build-up. Failure to do so can cause rotating parts to score or seize.
 - Avoid cavitation. Failure to do so can cause damage to the internal surfaces of the pump.
-

Operation under freezing conditions

NOTICE:

Do not expose an idle pump to freezing conditions. Drain all liquid that is inside the pump and the cooling coils. Failure to do so can cause liquid to freeze and damage the pump.

5.8 Shut down the pump

1. Slowly close the discharge valve.
2. Shut down and lock the driver to prevent accidental rotation.

6 Maintenance

6.1 Disassembly

6.1.1 Disassembly precautions

This manual clearly identifies accepted methods for disassembling units. These methods must be adhered to.



WARNING:

- Make sure that the pump is isolated from the system and that pressure is relieved before you disassemble the pump, remove plugs, open vent or drain valves, or disconnect the piping.
 - Always disconnect and lock out power to the driver before you perform any installation or maintenance tasks. Failure to disconnect and lock out driver power will result in serious physical injury.
 - Crush hazard. The unit and the components can be heavy. Use proper lifting methods and wear steel-toed shoes at all times.
 - After you disassemble a gasket joint, always use a new gasket upon reassembly. Never reuse old gaskets. Failure to follow these instructions can result in serious personal injury, death, and/or property damage.
 - Trapped liquid can rapidly expand and result in a violent explosion and injury. Never apply heat to impellers, propellers, or their retaining devices to aid in their removal.
-

NOTICE:

Make sure that all replacement parts are available before you disassemble the pump for overhaul.



Electrical Hazard:

- Before attempting to use the unit, check that it is unplugged and that the pump and the control panel cannot restart, even unintentionally. This also applies to the auxiliary control circuit of the pump.
 - Before any interventions on the unit, the network power supply and any other input voltages must be disconnected for five minutes (the capacitors of the intermediate circuit must be discharged by the built-in discharge resistors).
-

1. Make sure that the cooling fan and the vents are free from dust.
2. Make sure that the ambient temperature is correct according to the limits of the unit.
3. Make sure that qualified personal perform all modifications of the unit.
4. Make sure that the unit is disconnected from the power supply before any work is carried out. Always consider the pump and motor Instruction.

Function and parameter control

In case of changes to the hydraulic system:

1. Make sure that all functions and parameters are correct
 2. Adjust the functions and parameters if necessary.
-



WARNING: Magnetic Hazard

Magnetic fields can damage cardiac pacemaker and other medical implants. Stay clear of the permanent-magnet rotor, when disassembled from the motor.

6.1.2 Drain the pump



CAUTION:

- Allow all system and pump components to cool before you handle them to prevent physical injury.

1. Disconnect the electrical supply and lock it out of service.
2. Loosen the conduit box cover screws and remove the cover.
3. Disconnect the conduit and wiring.
4. Close the isolation valves on the suction and discharge sides of the pump.
You must drain the system if no valves are installed.
5. Open the drain valve.
Do not proceed until liquid stops coming out of the drain valve. If liquid continues to flow from the drain valve, the isolation valves are not sealing properly and you must repair them before you proceed.
6. Leave the drain valve open.
Do not close the drain valve until the reassembly is complete.
7. Drain the liquid from the piping and flush the pump if it is necessary.
8. Disconnect all auxiliary piping and tubing.
9. Loosen the volute capscrews but do not remove them.
10. Shift the pump position slightly in order to allow the pressurized water to escape.



WARNING:

Pressurized device. Make sure that the internal pressure is relieved before you continue.

11. Remove the volute capscrews and remove the pump assembly from the volute.

6.1.3 Typical cross section

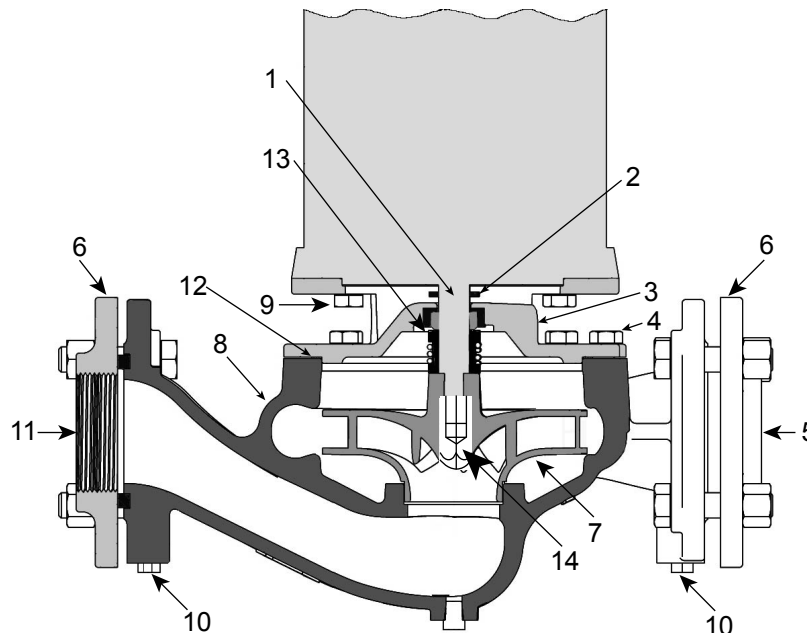

1. Shaft	8. Volute
2. Slinger	9. Motor capscrew
3. Bracket coverplate	10. Gauge tapping

4. Volute capscrew	11. Suction
5. Discharge	12. Volute gasket
6. Companion flange	13. Seal assembly
7. Impeller	14. Jamnut

Figure 8: Typical cross section

6.1.4 Remove the seal assembly for all sizes

1. Remove the motor assembly from the system.
2. Remove the plug or cover from the motor rear end plate. This will allow access to the end of the motor shaft. A slot or wrench flats are provided on the end of the shaft to retain the shaft during assembly and disassembly.
3. Use a large screwdriver or an end wrench to hold the shaft socket and a socket wrench to remove the jamnut. The jamnut is held in place with Loctite. Continue to hold the shaft and turn the impeller counterclockwise to remove it from the motor shaft.

NOTICE:

These seal assemblies consist of a stationary seal insert assembly and a rotating seal assembly. Each of these components must be replaced when you replace the mechanical seal. Never replace individual components separately.

4. Grab the OD of the seal head assembly and remove. Remove the four cap screws that hold the bracket to the motor and remove the bracket. Push the cup-mounted seal seat out of the bracket with a small screwdriver.
5. Clean the motor shaft and bracket recess with a clean lint free cloth.

6.2 Pre-assembly inspections

Guidelines

Before you assemble the pump parts, make sure you follow these guidelines:

- Inspect the pump parts according to the information in these pre-assembly topics before you reassemble your pump. Replace any part that does not meet the required criteria.
- Make sure that the parts are clean. Clean the pump parts in solvent in order to remove oil, grease, and dirt.

NOTICE:

Protect machined surfaces while you clean the parts. Failure to do so may result in equipment damage.

6.2.1 Replacement guidelines

Impeller replacement

This table shows the criteria for replacing the impeller:

Impeller parts	When to replace
Impeller vanes	<ul style="list-style-type: none"> • When grooved deeper than 1/16 in. (1.6 mm), or • When worn evenly more than 1/32 in. (0.8 mm)
Vane edges	When you see cracks, pitting, or corrosion damage
Impeller eye	When worn or grooved more than 1/16 in.(1.6 mm)
Jamnut	When impeller is replaced

Gaskets, O-rings, and seal replacement

- Replace all gaskets and O-rings at each overhaul and disassembly.
- Inspect the seats. They must be smooth and free of physical defects.
- Replace parts if the seal faces or elastomer are damaged.

6.3 Reassembly

6.3.1 Reassemble the seal assembly



WARNING:

After you disassemble a gasket joint, always use a new gasket upon reassembly. Never reuse old gaskets. Failure to follow these instructions can result in serious personal injury, death, and/or property damage.

1. Lubricate the OD of the cup mounted seal seat with soapy water or P80 Rubber Lubricant and push into the bracket.
2. Install the bracket onto the motor.
3. Check that the seal faces are clean. Lubricate the ID of the seal head assembly with soapy water or P80 and push onto the motor shaft.
The seal head assembly is a unitized design and should not be disassembled.
4. Clean the motor and impeller, and jamnut threads. . Apply Loctite 7471 Primer to the threads of the jamnut. Allow to dry. Apply a small amount of Loctite Retaining Compound 609 or 680 to the threads. Care must be used when applying Loctite so that it does not get on surrounding areas.
5. Screw the impeller onto the motor shaft. Using a large screwdriver or an end wrench and a strap wrench on the impeller OD, tighten the impeller to the motor shaft. Torque the impeller to 20-25 ft-lbs. 25 ft-lbs can be approximated by turning the impeller until the impeller hub is firmly against the motor shaft shoulder and then turning an additional 15 degrees.
6. While holding the shaft, screw the jamnut onto the shaft. Torque the jamnut to 20–25 ft-lbs.
NOTE: On three phase motors it is very important to follow these instructions. Failure to comply could allow the impeller to come loose during the motor rotation check if the motor starts in reverse rotation.
7. Clean the bracket and volute gasket surfaces. Install a new gasket on the bracket.
8. Insert the motor assembly back into the pump casing. Tighten the casing capscrews evenly.
9. Close the drain value and open the isolation valves. Inspect pump for leaks. If not leaking, return pump to service. Reconnect the electrical service.

6.3.2 Capscrew torque values

Capscrew torque in ft-lbs (Nm)

Capscrew type	Head marking	1/4 in.	5/16 in.	3/8 in.	7/16 in.	1/2 in.	5/8 in.	3/4 in.	7/8 in.	1 in.
SAE grade 2		6 (8)	13 (18)	25 (34)	38 (52)	60 (81)	120 (163)	190 (258)	210 (285)	300 (407)
Brass or stainless steel	 or 	4 (5)	10 (14)	17 (23)	27 (37)	42 (57)	83 (113)	130 (176)	200 (271)	300 (407)

Capscrew type	Head marking	1/4 in.	5/16 in.	3/8 in.	7/16 in.	1/2 in.	5/8 in.	3/4 in.	7/8 in.	1 in.
SAE grade 5		10 (14)	20 (27)	35 (47)	60 (81)	90 (122)	180 (244)	325 (441)	525 (712)	800 (1085)

6.3.3 Dealer servicing

If trouble occurs that cannot be rectified, contact your local sales and service representative and be prepared to provide this information:

1. Complete nameplate data of pump and motor
2. Suction and discharge pipe pressure gauge readings
3. Ampere draw of the motor
4. A sketch of the pump hook-up and piping

7 Troubleshooting

Operation troubleshooting

In case of alarm or error, the display shows an ID code and the STATUS LED turns on (also see Par. 6.4.2).

In case of several alarms and/or errors, the display shows the main one.

Alarms and errors:

- are saved with date and time
- can be reset by switching the unit off for at least 1 minute.

Errors cause the triggering of the status relay on the following terminal box pins:

- single-phase version: pins 4 and 5
- three-phase version: pins 24 and 25

7.1 Alarm codes

code	Description	Cause	Remedy
A03	Derating	Temperature too high	<ul style="list-style-type: none"> • Lower the room temperature • Lower the water temperature • Lower the load
A05	Data memory alarm	Data memory corrupted	<ol style="list-style-type: none"> 1. Reset the default parameters using parameter P68 2. Wait 10 s 3. Restart the pump <p>If the problem continues, contact Xylem or the Authorised Distributor</p>
A06	LOW alarm	Lack of water detection (if P48=ALR)	Check the water level inside the tank
A15	EEPROM write failure	Data memory damaged	Stop the pump for 5 minutes and then restart it again; if the problem continues, contact Xylem or the Authorised Distributor
A20	Internal alarm		Stop the pump for 5 minutes and then restart it again; if the problem continues, contact Xylem or the Authorised Distributor
A30	Multi-pump connection alarm	Corrupted multi-pump connection	<ul style="list-style-type: none"> • Check the condition of the connection cables • Check that there are no address discrepancies
A31	Loss of multi-pump connection	Loss of multi-pump connection	Check the condition of the connection cables

7.2 Error codes

code	Description	Cause	Remedy
E01	Internal communication error	Internal communication lost	Stop the pump for 5 minutes and then restart it again; if the problem continues, contact Xylem or the Authorised Distributor

code	Description	Cause	Remedy
E02	Motor overload error	<ul style="list-style-type: none"> High motor current Current absorbed by the motor too high 	Stop the pump for 5 minutes and then restart it again; if the problem continues, contact Xylem or the Authorised Distributor
E03	DC-bus overvoltage error	<ul style="list-style-type: none"> DC-bus overvoltage External conditions cause the operation of the pump from generator 	Check: <ul style="list-style-type: none"> the system configuration the position and integrity of the non-return valves
E04	Rotor blocked	<ul style="list-style-type: none"> Motor stall Loss of rotor synchronism or rotor blocked by external materials 	<ul style="list-style-type: none"> Check that there are no foreign bodies preventing the pump from turning Stop the pump for 5 minutes and then start it again If the problem continues, contact Xylem or the Authorised Distributor
E05	EEPROM Data memory error	EEPROM Data memory corrupted	Stop the pump for 5 minutes and then restart it again; if the problem continues, contact Xylem or the Authorised Distributor
E06	Grid voltage error	Voltage supply out of operating range	Check: <ul style="list-style-type: none"> the voltage the connection of the electric system
E07	Motor winding temperature error	Motor thermal protection trip	<ul style="list-style-type: none"> Check for impurities near the impeller and rotor. Remove them if necessary Check the conditions of installation and the water and air temperature Wait for the motor to cool down If the error persists, stop the pump for 5 minutes and then start it again If the problem continues, contact Xylem or the Authorised Distributor
E08	Power module temperature error	Frequency converter thermal protection trip	Check the conditions of installation, and the air temperature
E09	Generic hardware error	Hardware error	Stop the pump for 5 minutes and then restart it again; if the problem continues, contact Xylem or the Authorised Distributor
E11	LOW error	Lack of water detection (if P48=ERR)	Check the water level inside the tank
E12	Pressure sensor error	Missing pressure sensor (not present in ACT mode)	Check the condition of the sensor connection cables

code	Description	Cause	Remedy
E14	Low pressure error	Pressure below minimum threshold (not present in ACT mode)	Check the settings of parameters P45 and P46
E15	Loss of phase error	One of the three power supply phases is missing (three-phase versions only)	Check the connection to the power supply network
E30	Multi-pump protocol error	Incompatible multi-pump protocol	Bring all the units to the same firmware version
E44	External analogue reference error	External analogue signal missing or out of range (if P40 = ISP)	Check: <ul style="list-style-type: none">• The P40 parameter setting• External analog signal source and cables (terminals 9–10 for the single-phase version, terminals 17–18 for the three-phase version)

See also Par. 6.3.2 and Par. 6.4.3.

8 Technical Specification

8.1 Electrical and environmental specifications

	e-SM Drive model										
	103	105	107	111	115	303	305	307	311	315	322
Input											
Input frequency [Hz]	50/60 ± 2										
Main supply	L1 L2					L1 L2 L3					
Nominal input voltage [V]	208-240 ±10%					208-240 / 380-460 ±10%					380-460 ±10%
Maximum current absorbed (AC) in continuous service (S1) [A]	See data plate										
PDS Efficiency Class	IES2										
Output											
Min.-Max. Speed [rpm]	1200 - 3600										
Leakage Current [mA]	< 3,5										
I/O auxiliar + 15VDC power supply [mA]	I _{max} < 40										
Fault signal relay	1 x NO V _{max} < 250 [VAC] , I _{max} < 2 [A]					1 x NO V _{max} < 250 [VAC] , I _{max} < 2 [A]					
Motor status relay	-					1 x NO V _{max} < 250 [VAC] , I _{max} < 2 [A]					
EMC (Electro Magnetic Compatibility)	Installations must be performed in accordance with the EMC good practice guidelines (e.g. avoid "eyebolts" on the transmission side)										
Sound pressure L _{pA} [dB(A)] @ [rpm]	< 62 @3000 < 66 @3600										
Insulation class	155 F										
Protection class	IP 55, Enclosure NEMA Type 3R										

	e-SM Drive model										
	103	105	107	111	115	303	305	307	311	315	322
Relative humidity (storage & operating)	5%-95% UR										
Storage temperature [°F] / [°C]	-13-149 / -25-65										
Operating temperature [°F] / [°C]	-4-122 / -20-50										
Air Pollution	Pollution Degree 2										
Installation altitude a.s.l. [ft] / [m]	< 3280 / 1000 Derating may occur at higher altitudes										

8.2 Dimensions and weights

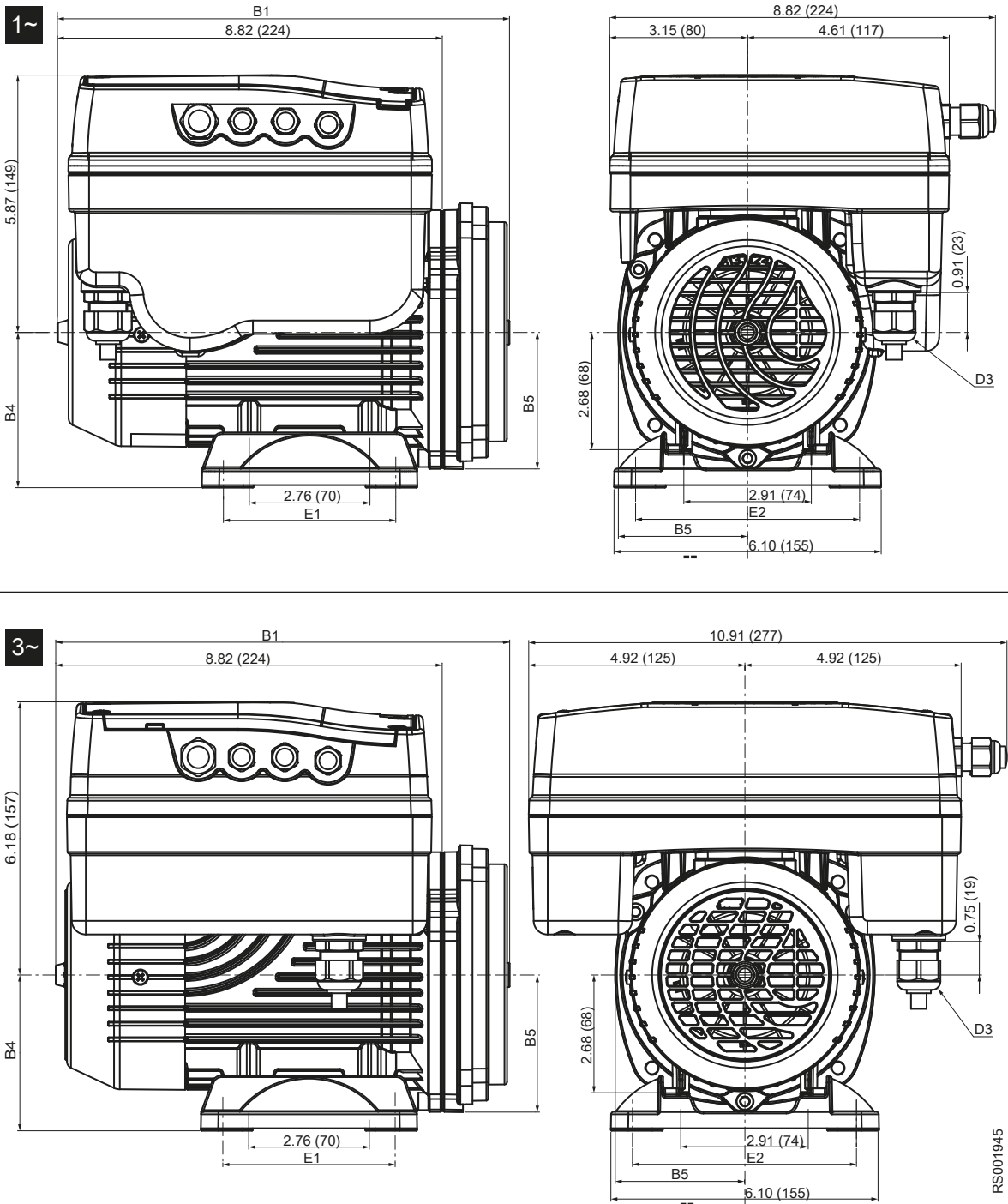

Figure 9: Dimensions [in. (mm)]

RS001945

Table 10: Dimensions and weights

Model	Net weight (motor + drive) [lb (kg)]					B1	B4	B5	D3	E1	E2
	1~		3~								
	103 105 107	111 115	303 305 307	311 315	322						
ESM80... HMHA	16.53 (7.5)	19.84 (9)	28.66 (13)	31.97 (14.5)	35.27 (16)	10.35 (263)	3.54 (90)	3.11 (79)	M20	3.94 (100)	4.92 (125)
ESM80... HMHB	16.76 (7.6)	202.3 (9.2)	29.10 (13.2)	32.19 (14.6)	35.49 (16.1)	10.55 (268)	3.54 (90)	3.15 (80)		3.94 (100)	4.92 (125)
ESM80... HMHC	17.42 (7.9)	20.72 (9.4)	29.54 (13.4)	32.63 (14.8)	36.16 (16.4)	10.71 (272)	3.54 (90)	3.58 (91)		3.94 (100)	4.92 (125)
ESM90R. ..56C	15.87 (7.2)	19.40 (8.8)	27.78 (12.6)	31.53 (14.3)	34.83 (15.8)	11.57 (294)	—	3.27 (83)	NPT 1/2"	—	—
... = 103, 105, 107, 111, 115, 303, 305, 307, 311, 315, 322 - = motor foot is not included.											

9 Cybersecurity

Xylem values system security and resilience. Defending against cybersecurity threats is a shared responsibility. Xylem builds products that are secure by design. Our customers have a responsibility to understand the risks inherent in their processes and take steps to operate and maintain their solutions securely. This section reviews security features and provides guidance to help securely operate this product. For details and updates on Xylem product cybersecurity visit xylem.com/security

Xylem product cybersecurity

Xylem performs appropriate due care in building security and resilience into products. Xylem performs the following security activities for defense-in-depth:

- Security engineers perform threat modeling to identify testable controls
- Code is scanned for flaws with **static analysis** tools and hardened
- **Product components are analyzed** and hardened
- Security controls are verified through automated and manual tests
- Xylem maintains relationships with customers, integrators, and the cybersecurity research community and the **Product Security Incident Response Team (PSIRT)** coordinates the collection, analysis, remediation, and responsible disclosure of vulnerability and remediation information to keep products secure
- Cloud connections, data flows, and cloud infrastructure are continuously monitored by the Product Security Operations Center (PSOC)
- Product security is **governed through a three lines of defense** model that includes: product developers, product security engineers, and audit staff

Security Recommendations for End-User

eSM (the motor/VFD portion of the e-90E system) is developed considering security best practices. The following guidance provides recommendation for secure operations, hardening and account management. In the table below: *Safeguards* describe the security guidance, *Security Context & Rationale* provide overview of security features and value of the security safeguard, and *References* provide additional resources for further investigation for implementing the recommended safeguards.

Safeguard	Security Context & Rationale	References
Restrict physical access <ul style="list-style-type: none"> • Ensure physical access to assets is limited. Include physical isolation to protect the environment and equipment therein. • Ensure strict control over physical access in and out of the facility. 	The communication ports have been hardened to restrict access and ensure integrity of device operations. This safeguard supports the ability to further limit exposure associated with physical threats to the device such as rogue/malicious device joining the Modbus RTU network over RS485 interface.	ATT&CK for ICS: M0801 NIST SP 800-53 Rev5: AC-3, PE-3 ISA/IEC 62443-3-3: SR 2.1
Ensure cybersecurity policies, awareness, and training to the operators, administrators and other personnel.	This safeguard prevents Social Engineering attacks and promotes awareness related to cybersecurity.	ATT&CK for ICS: M0917 NIST SP 800-53 Rev5: AT-2 ISA/IEC 62443-2-4: SP.01

Safeguard	Security Context & Rationale	References
Ensure patch management is done regularly and updated appropriately.	This safeguard prevents attacks related using components with known vulnerabilities. Sometime vulnerabilities are discovered, and we work with our partners to deploy updates to security and resilience. This safeguard mitigates exploitation risks and ensures security patching	ATT&CK for ICS: M0951 NIST SP 800-53 Rev5: MA-2 ISA/IEC 62443-2-3
Ensure hardening guidelines are implemented, only desired ports and services should be open, and RBAC should be followed.	This safeguard helps in prevention of attacks due to misconfigurations or default configurations.	ATT&CK for ICS: M0937, M0918, M0801 NIST SP 800-53 Rev5: AC-3(7), SC-7(5) ISA/IEC 62443-3-3: SR 2.1, SR 5.1
Ensure strong password policy is implemented and default credentials should not be used, passwords must be changed periodically.	This safeguard will help in prevention of passwords and account takeover attacks.	ATT&CK for ICS: M0927 NIST SP 800-53 Rev5: IA-5 ISA/IEC 62443-3-3: SR 1.7
Create and exercise disaster recovery plans.	eSM (the motor/VFD portion of the e-90E system) has no way to perform a back-up of the current system configuration but can revert to factory settings via Display or via Modbus. Defining this process provides systems resilience, including against ransomware.	ATT&CK for ICS: M0953 NIST SP 800-53 Rev5: CP-10 ISA/IEC 62443-3-3: SR 7.4
Implement specific inventory, logging and monitoring of hardware and report security-related incidents to Xylem at product.security@xylem.com. These might include unexpected operations, confirmed tampering, or theft of the device.	Devices are hardened and Xylem provides PSIRT to help customers investigate potential security incidents. This safeguard supports the ability to track assets and recognize potential security events.	ATT&CK for ICS: M0947 NIST SP 800-53 Rev5: SM-8 ISA/IEC 62443-3-3: SR 1.11, SR 2.8, SR 3.4

For additional information see references:

1. ATT&CK for ICS available online: <https://collaborate.mitre.org/attackics/index.php/Mitigations>
2. NIST SP 800-53 Rev 5 available online: <https://nvlpubs.nist.gov/nistpubs/SpecialPublications/NIST.SP.800-53r5.pdf>
3. ISA/IEC 62443 standards available for purchase from ISA, IEC, or ANSI.

10 Product Warranty

Commercial warranty

Warranty. For goods sold to commercial buyers, Seller warrants the goods sold to Buyer hereunder (with the exception of membranes, seals, gaskets, elastomer materials, coatings and other "wear parts" or consumables all of which are not warranted except as otherwise provided in the quotation or sales form) will be (i) be built in accordance with the specifications referred to in the quotation or sales form, if such specifications are expressly made a part of this Agreement, and (ii) free from defects in material and workmanship for a period of one (1) year from the date of installation or eighteen (18) months from the date of shipment (which date of shipment shall not be greater than thirty (30) days after receipt of notice that the goods are ready to ship), whichever shall occur first, unless a longer period is specified in the product documentation (the "Warranty").

Except as otherwise required by law, Seller shall, at its option and at no cost to Buyer, either repair or replace any product which fails to conform with the Warranty provided Buyer gives written notice to Seller of any defects in material or workmanship within ten (10) days of the date when any defects or non-conformance are first manifest. Under either repair or replacement option, Seller shall not be obligated to remove or pay for the removal of the defective product or install or pay for the installation of the replaced or repaired product and Buyer shall be responsible for all other costs, including, but not limited to, service costs, shipping fees and expenses. Seller shall have sole discretion as to the method or means of repair or replacement. Buyer's failure to comply with Seller's repair or replacement directions shall terminate Seller's obligations under this Warranty and render the Warranty void. Any parts repaired or replaced under the Warranty are warranted only for the balance of the warranty period on the parts that were repaired or replaced. Seller shall have no warranty obligations to Buyer with respect to any product or parts of a product that have been: (a) repaired by third parties other than Seller or without Seller's written approval; (b) subject to misuse, misapplication, neglect, alteration, accident, or physical damage; (c) used in a manner contrary to Seller's instructions for installation, operation and maintenance; (d) damaged from ordinary wear and tear, corrosion, or chemical attack; (e) damaged due to abnormal conditions, vibration, failure to properly prime, or operation without flow; (f) damaged due to a defective power supply or improper electrical protection; or (g) damaged resulting from the use of accessory equipment not sold or approved by Seller. In any case of products not manufactured by Seller, there is no warranty from Seller; however, Seller will extend to Buyer any warranty received from Seller's supplier of such products.

THE FOREGOING WARRANTY IS EXCLUSIVE AND IN LIEU OF ANY AND ALL OTHER EXPRESS OR IMPLIED WARRANTIES, GUARANTEES, CONDITIONS OR TERMS OF WHATEVER NATURE RELATING TO THE GOODS PROVIDED HEREUNDER, INCLUDING WITHOUT LIMITATION ANY IMPLIED WARRANTIES OF MERCHANTABILITY AND FITNESS FOR A PARTICULAR PURPOSE, WHICH ARE HEREBY EXPRESSLY DISCLAIMED AND EXCLUDED. EXCEPT AS OTHERWISE REQUIRED BY LAW, BUYER'S EXCLUSIVE REMEDY AND SELLER'S AGGREGATE LIABILITY FOR BREACH OF ANY OF THE FOREGOING WARRANTIES ARE LIMITED TO REPAIRING OR REPLACING THE PRODUCT AND SHALL IN ALL CASES BE LIMITED TO THE AMOUNT PAID BY THE BUYER FOR THE DEFECTIVE PRODUCT. IN NO EVENT SHALL SELLER BE LIABLE FOR ANY OTHER FORM OF DAMAGES, WHETHER DIRECT, INDIRECT, LIQUIDATED, INCIDENTAL, CONSEQUENTIAL, PUNITIVE, EXEMPLARY OR SPECIAL DAMAGES, INCLUDING BUT NOT LIMITED TO LOSS OF PROFIT, LOSS OF ANTICIPATED SAVINGS OR REVENUE, LOSS OF INCOME, LOSS OF BUSINESS, LOSS OF PRODUCTION, LOSS OF OPPORTUNITY OR LOSS OF REPUTATION.

Limited consumer warranty

Warranty. For goods sold for personal, family or household purposes, Seller warrants the goods purchased hereunder (with the exception of membranes, seals, gaskets, elastomer

materials, coatings and other "wear parts" or consumables all of which are not warranted except as otherwise provided in the quotation or sales form) will be free from defects in material and workmanship for a period of one (1) year from the date of installation or eighteen (18) months from the product date code, whichever shall occur first, unless a longer period is provided by law or is specified in the product documentation (the "Warranty").

Except as otherwise required by law, Seller shall, at its option and at no cost to Buyer, either repair or replace any product which fails to conform with the Warranty provided Buyer gives written notice to Seller of any defects in material or workmanship within ten (10) days of the date when any defects or non-conformance are first manifest. Under either repair or replacement option, Seller shall not be obligated to remove or pay for the removal of the defective product or install or pay for the installation of the replaced or repaired product and Buyer shall be responsible for all other costs, including, but not limited to, service costs, shipping fees and expenses. Seller shall have sole discretion as to the method or means of repair or replacement. Buyer's failure to comply with Seller's repair or replacement directions shall terminate Seller's obligations under this Warranty and render this Warranty void. Any parts repaired or replaced under the Warranty are warranted only for the balance of the warranty period on the parts that were repaired or replaced. The Warranty is conditioned on Buyer giving written notice to Seller of any defects in material or workmanship of warranted goods within ten (10) days of the date when any defects are first manifest.

Seller shall have no warranty obligations to Buyer with respect to any product or parts of a product that have been: (a) repaired by third parties other than Seller or without Seller's written approval; (b) subject to misuse, misapplication, neglect, alteration, accident, or physical damage; (c) used in a manner contrary to Seller's instructions for installation, operation and maintenance; (d) damaged from ordinary wear and tear, corrosion, or chemical attack; (e) damaged due to abnormal conditions, vibration, failure to properly prime, or operation without flow; (f) damaged due to a defective power supply or improper electrical protection; or (g) damaged resulting from the use of accessory equipment not sold or approved by Seller. In any case of products not manufactured by Seller, there is no warranty from Seller; however, Seller will extend to Buyer any warranty received from Seller's supplier of such products.

THE FOREGOING WARRANTY IS PROVIDED IN PLACE OF ALL OTHER EXPRESS WARRANTIES. ALL IMPLIED WARRANTIES, INCLUDING BUT NOT LIMITED TO THE IMPLIED WARRANTIES OF MERCHANTABILITY AND FITNESS FOR A PARTICULAR PURPOSE, ARE LIMITED TO ONE (1) YEAR FROM THE DATE OF INSTALLATION OR EIGHTEEN (18) MONTHS FROM THE PRODUCT DATE CODE , WHICHEVER SHALL OCCUR FIRST. EXCEPT AS OTHERWISE REQUIRED BY LAW, BUYER'S EXCLUSIVE REMEDY AND SELLER'S AGGREGATE LIABILITY FOR BREACH OF ANY OF THE FOREGOING WARRANTIES ARE LIMITED TO REPAIRING OR REPLACING THE PRODUCT AND SHALL IN ALL CASES BE LIMITED TO THE AMOUNT PAID BY THE BUYER FOR THE DEFECTIVE PRODUCT. IN NO EVENT SHALL SELLER BE LIABLE FOR ANY OTHER FORM OF DAMAGES, WHETHER DIRECT, INDIRECT, LIQUIDATED, INCIDENTAL, CONSEQUENTIAL, PUNITIVE, EXEMPLARY OR SPECIAL DAMAGES, INCLUDING BUT NOT LIMITED TO LOSS OF PROFIT, LOSS OF ANTICIPATED SAVINGS OR REVENUE, LOSS OF INCOME, LOSS OF BUSINESS, LOSS OF PRODUCTION, LOSS OF OPPORTUNITY OR LOSS OF REPUTATION.

Some states do not allow limitations on how long an implied warranty lasts, so the above limitation may not apply to you. Some states do not allow the exclusion or limitation of incidental or consequential damages, so the above exclusions may not apply to you. This warranty gives you specific legal rights, and you may also have other rights which may vary from state to state.

To make a warranty claim, check first with the dealer from whom you purchased the product or visit www.xyleminc.com for the name and location of the nearest dealer providing warranty service.

Xylem |'zīləm|

- 1) The tissue in plants that brings water upward from the roots;
- 2) a leading global water technology company.

We're a global team unified in a common purpose: creating advanced technology solutions to the world's water challenges. Developing new technologies that will improve the way water is used, conserved, and re-used in the future is central to our work. Our products and services move, treat, analyze, monitor and return water to the environment, in public utility, industrial, residential and commercial building services settings. Xylem also provides a leading portfolio of smart metering, network technologies and advanced analytics solutions for water, electric and gas utilities. In more than 150 countries, we have strong, long-standing relationships with customers who know us for our powerful combination of leading product brands and applications expertise with a strong focus on developing comprehensive, sustainable solutions.

For more information on how Xylem can help you, go to www.xylem.com



Xylem Inc.
8200 N. Austin Avenue
Morton Grove, IL 60053
Tel: (847) 966-3700
Fax: (847) 965-8379
www.xylem.com/bellgossett

Visit our Web site for the latest version of this document and more information

The original instruction is in English. All non-English instructions are translations of the original instruction.

© 2023 Xylem Inc.

Xylem and Bell & Gossett are registered trademarks of Xylem Inc. or one of its subsidiaries. All other trademarks or registered trademarks are property of their respective owners.