



COMMERCIAL GAS REPLACEMENT PARTS LIST

Flue Damper Electronic Ignition Models

Models Covered:

D38T155(E)*(N,X) / D65T370(E)*(N,X)(A)
D65T399(E)*N(A) / D75T(125, 160)(E)*(N,X)
D75T300*(N,X)(A) / D80L399(E)*(N,X)(A)
D80L(450, 505)*(N,X)(A) / D80T(180,199)(E)*(N,X)
D80T250(E)*(N,X)(A) / D80T(425, 505)*(N,X)(A)
D100L199(E)*(N,X) / D100L250(E)*(N,X)(A)
D100L270(E)*N(A) / D100L300(E)*(N,X)(A)
D100S199(E)*(N,X) / D100S250(E)*(N,X)(A)
D100T199(E)*(N,X) / D100T250(E)*(N,X)(A)

*Denotes warranty year



Includes Hydrojet®
Total Performance System

Effective: January, 2023
ECO 8248-3

**NOTE: BOTH MODEL AND SERIAL
NUMBERS ARE REQUIRED FOR
ORDERING REPLACEMENT PARTS**

Dimensions and specifications
subject to change without notice.



As required by the state of California Proposition 65.

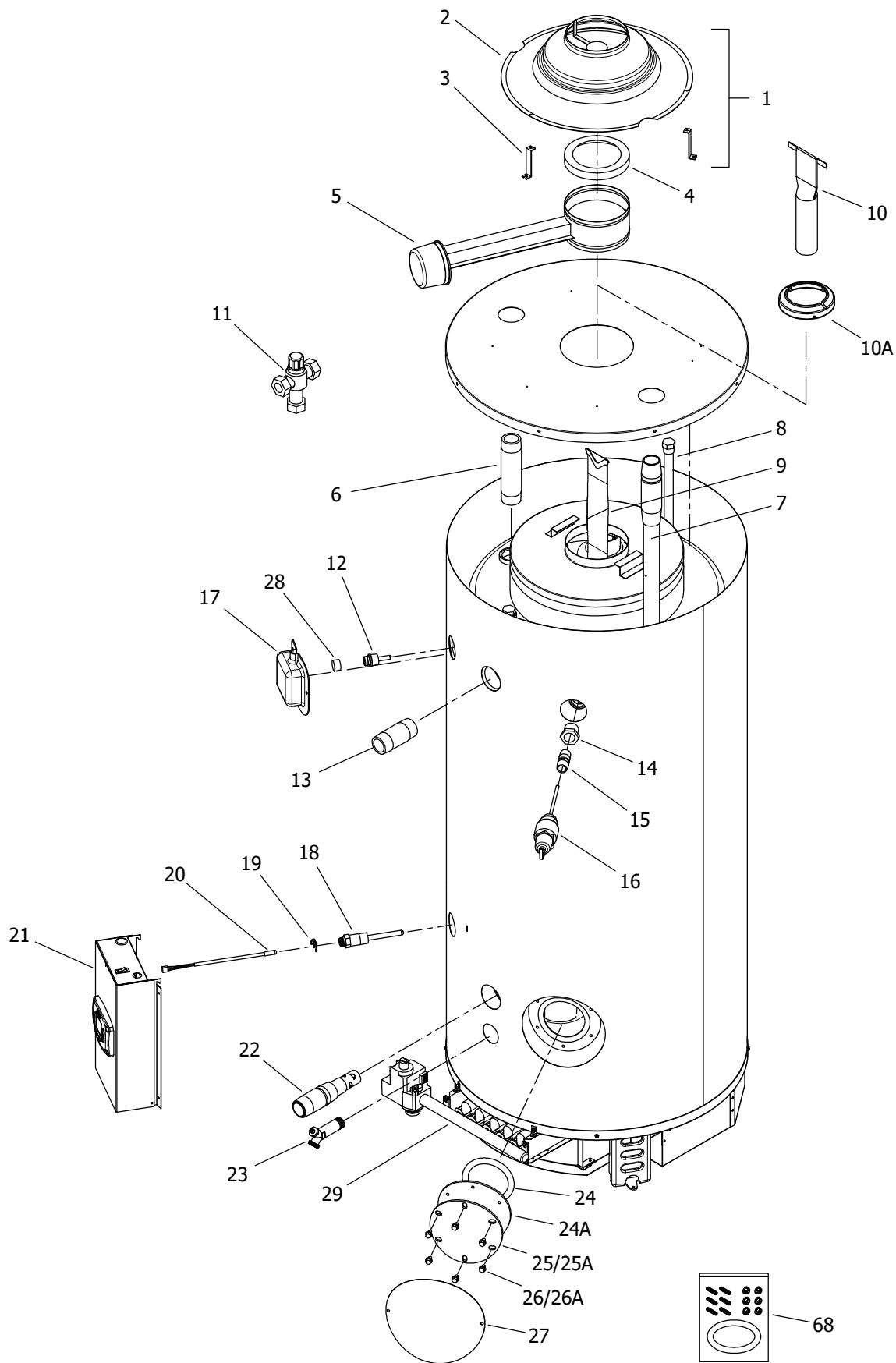

Item	Description	Model	Model	Model	Model
		D38T155(E)*(N,X)	D65T370(E)*(N,X)(A)	D65T399(E)*N(A)	D75T125(E)*(N,X)
1	Draft Diverter Complete with Leg Kit	265-46541-00	265-46546-00	265-46546-00	265-46542-00
2	Draft Diverter Only	239-81733-00-01	239-81992-00-01	239-81992-00-01	239-82000-01-01
3	Draft Diverter Leg Kit Only	243-43690-02	243-43691-04	243-43691-04	243-43689-02
4	Flue Damper Reducer	---	---	---	239-81980-00
5	Flue Damper Complete	415-42973-00	415-42974-00	415-42974-00	265-43112-00
6	Hot Water Outlet Nipple (Top)	---	---	---	229-40913-01
7	Cold Water Inlet Diptube (Top)	---	---	---	415-46709-01
8	Plug Type Anode Rod (Magnesium)#	224-47782-09 (Qty. 3)	224-47782-11 (Qty. 3)	224-47782-11 (Qty. 3)	224-47782-06 (Qty. 2)
	Plug Type Anode Rod (Aluminum)#	224-38508-02 (Qty. 3)	224-38508-07 (Qty. 3)	224-38508-07 (Qty. 3)	224-38508-06 (Qty. 2)
	Plug Type Anode Rod (A420 Aluminum)#	224-49559-04 (Qty. 3)	224-49559-04 (Qty. 3)	224-49559-04 (Qty. 3)	224-49559-04 (Qty. 2)
9	Flue Baffle	243-81683-00 (Qty. 11)	243-39327-00 (Qty.16)	243-82076-00 (Qty.16)	---
10	Flue Core	---	---	---	239-50666-00 (Qty. 2)
10A	Flue Reducer	---	---	---	243-54363-00 (Qty. 2)
11	ASSE Approved Mixing Valve (Optional)	239-51778-00	239-51778-00	239-51778-00	239-51778-00
12	Upper Thermostat Sensor	---	415-82033-00	415-82033-00	---
13	Hot Water Outlet Nipple (Side)	229-40913-02	229-40913-02	229-40913-02	229-40913-02
14	1" NPT to 3/4" NPT Reducer Bushing	239-02052-00	---	---	---
15	3/4" NPT Nipple	229-32762-04	---	---	229-32762-04
	1" NPT Nipple	---	229-32762-19	229-32762-19	---
16	T&P Valve	415-30246-00	415-33630-04	415-33630-04	415-30246-00
17	Utility Cover	---	239-80281-03	239-80281-03	239-80281-03
18	Lower Thermostat Well	233-46558-02	233-46558-02	233-46558-02	233-46558-02
19	Clip for Lower Thermostat	233-45242-00	233-45242-00	233-45242-00	233-45242-00
20	Lower Thermostat Sensor	415-46553-01	415-46553-02	415-46553-02	415-46553-02
21	Control Box Assembly	243-46614-01	243-46560-01	243-46560-01	243-46614-02
22	Cold Water Inlet Diptube (Side)	415-44731-00	415-44731-00	415-44731-00	415-44731-00
23	Brass Drain Valve	415-42351-04	415-42351-04	415-42351-04	415-42351-04
24	Cleanout O-Ring Gasket	205-18427-00	205-18427-00	205-18427-00	205-18427-00
24A	Cleanout Gasket (ASME)	---	205-32942-00	205-32942-00	---
25	Cleanout Cover	205-18428-00	205-18428-00	205-18428-00	205-18428-00
25A	Cleanout Cover (ASME)	---	205-32941-00	205-32941-00	---
26	Cleanout Cover Screw	239-82166-00 (Qty. 6)	239-82166-00 (Qty. 6)	239-82166-00 (Qty. 6)	239-82166-00 (Qty. 6)
26A	Cleanout Cover Screw (ASME)	---	239-32970-00 (Qty. 6)	239-32970-00 (Qty. 6)	---
27	Cleanout Access Cover	243-20299-00	243-20299-00	243-20299-00	243-20299-00
28	Pipe Plug (3/4 NPT)	---	---	---	---
68	Kit-Cleanout (Not For Use With ASME Tanks)	415-54256-00	415-54256-00	415-54256-00	415-54256-00

* Applies to all warranties

** Ordering a complete burner rack may increase delivery time. Please order the specific component required for the quickest delivery.

*** No LP version model available.

**** No Low Nox versions available over 400K btuh.

Anode may need to be cut to length. See page 32.

▲ Applies when "E" is present in model number (Example: D38T155E3N).

¹ For serial numbers PRIOR to GB13067706.

² For serial numbers AFTER and including GB13067706.

³ For serial numbers PRIOR to HA14465923.

⁴ For serial numbers including and AFTER HA14465923

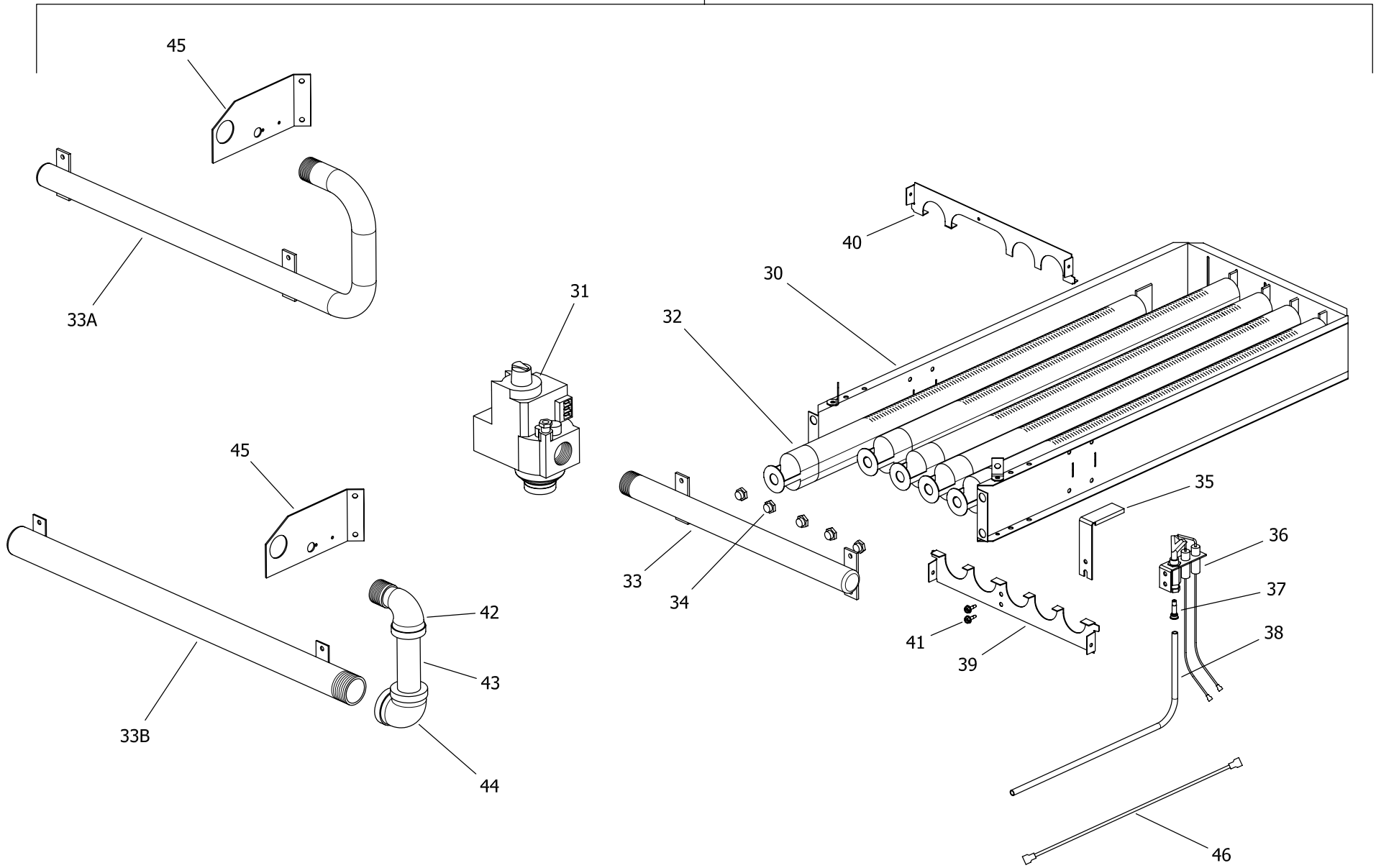

Item	Description	Model	Model	Model	Model
		D38T155(E)*(N,X)	D65T370(E)*(N,X)(A)	D65T399(E)*N(A)	D75T125(E)*(N,X)
29	Burner Rack Complete (Natural Gas) **	243-39205-18	243-39322-01	243-39322-03	243-39334-01
	Burner Rack Complete (Nat. Gas)(Lo NOX) **▲	243-42563-05	243-42558-01	243-42558-02	243-42559-01
	Burner Rack Complete (LP Gas) **	243-39205-04	243-39322-02	***	243-39334-02
30	Burner Rack Only	239-81969-01	239-81969-03	239-81969-03	243-82107-00
31	Gas Valve (Natural Gas)	415-80830-02	415-81608-03	415-81608-03	415-80830-02
	Gas Valve (LP Gas)	415-80831-02	415-80831-02	***	415-80831-02
32	Burner Tube (Standard)	228-39177-00 (Qty. 5)	228-39177-00 (Qty. 9)	228-39177-00 (Qty. 9)	228-39177-00 (Qty. 3)
	Burner Tube (Lo-NOX) ▲	228-42490-00 (Qty. 5)	228-42490-00 (Qty. 9)	228-42490-00 (Qty. 9)	228-42490-00 (Qty. 3)
33	Burner Manifold (Natural Gas)	233-39170-00	---	---	233-39174-00
	Burner Manifold (LP Gas)	233-39170-00	---	***	233-39174-00
33A	Burner Manifold (Natural Gas)	---	---	---	---
	Burner Manifold (LP Gas)	---	233-39173-00	***	---
33B	Burner Manifold (Natural Gas)	---	233-39171-00	233-39171-00	---
34	Main Burner Orifice (Natural Gas) (0ft to 2000ft)	234-06016-73 (Qty. 5)	234-06016-33 (Qty. 9)	234-06016-32 (Qty. 9)	234-06016-33 (Qty. 3)
	High Altitude (Natural Gas) (2001ft to 5000ft)	234-06016-42 (Qty. 5)	234-06016-36 (Qty. 9)	234-06016-35 (Qty. 9)	234-06016-36 (Qty. 3)
	High Altitude (Natural Gas) (5001ft to 8000ft)	234-06016-43 (Qty. 5)	234-06016-38 (Qty. 9)	234-06016-37 (Qty. 9)	234-06016-38 (Qty. 3)
	High Altitude (Natural Gas) (8001ft & above)	234-06016-44 (Qty. 5)	234-06016-39 (Qty. 9)	234-06016-38 (Qty. 9)	234-06016-39 (Qty. 3)
	Main Burner Orifice (LP Gas) (0ft to 2000ft)	234-06016-52 (Qty. 5)	234-06016-49 (Qty. 9)	***	234-06016-48 (Qty. 3)
	High Altitude (LP Gas) (2001ft to 5000ft)	234-06016-1/16 (Qty. 5)	234-06016-50 (Qty. 9)	***	234-06016-50 (Qty. 3)
	High Altitude (LP Gas) (5001ft to 8000ft)	234-06016-53 (Qty. 5)	234-06016-51 (Qty. 9)	***	234-06016-51 (Qty. 3)
	High Altitude (LP Gas) (8001ft & above)	234-06016-53 (Qty. 5)	234-06016-51 (Qty. 9)	***	234-06016-51 (Qty. 3)
35	Pilot Shield	239-41333-00	239-41333-00	239-41333-00	239-41333-00
36	Pilot Assembly (Natural Gas)	415-41323-01	415-41323-01	415-41323-01	415-41323-01
	Pilot Assembly (LP Gas)	233-41323-02	233-41323-02	***	233-41323-02
37	Pilot Orifice (Natural Gas)	233-41606-01	233-41606-01	233-41606-01	233-41606-01
	Pilot Orifice (LP Gas)	233-41606-02	233-41606-02	233-41606-02	233-41606-02
38	Aluminum Pilot Tube	233-80361-01	233-80361-01	233-80361-01	233-80361-01
39	Burner Support	239-45180-00	239-39259-00	239-39259-00	239-45180-00
40	Draft Panel	239-39419-00	239-39421-00	239-39421-00	239-39419-00
41	Pilot Mounting Screw	239-11706-00 (Qty. 2)	239-11706-00 (Qty. 2)	239-11706-00 (Qty. 2)	239-11706-00 (Qty. 2)
42	Sreet Elbow 1" NPT (Natural)	---	239-19636-00	***	---
43	Pipe Nipple 1" NPT (Natural)	---	239-81595-00	***	---
44	Elbow 1" NPT (Natural)	---	239-19637-00	***	---
45	Gas Support Bracket (Natural)	---	239-81816-01	239-81816-01	---
	Gas Support Bracket (LP)	---	239-81816-02	***	---
46	Ground Wire	239-38951-52	239-38951-52	239-38951-52	239-38951-52
-	LP to Natural Gas Conversion Kit	265-46033-01	265-46034-01	***	265-46033-02

* Applies to all warranties

** Ordering a complete burner rack may increase delivery time. Please order the specific component required for the quickest delivery.

*** No LP version model available.

**** No Low Nox versions available over 400K btuh.

Anode may need to be cut to length. See page 32.

▲ Applies when "E" is present in model number (Example: D38T155E3N).

¹ For serial numbers PRIOR to GB13067706.

² For serial numbers AFTER and including GB13067706.

³ For serial numbers PRIOR to HA14465923.

⁴ For serial numbers including and AFTER HA14465923

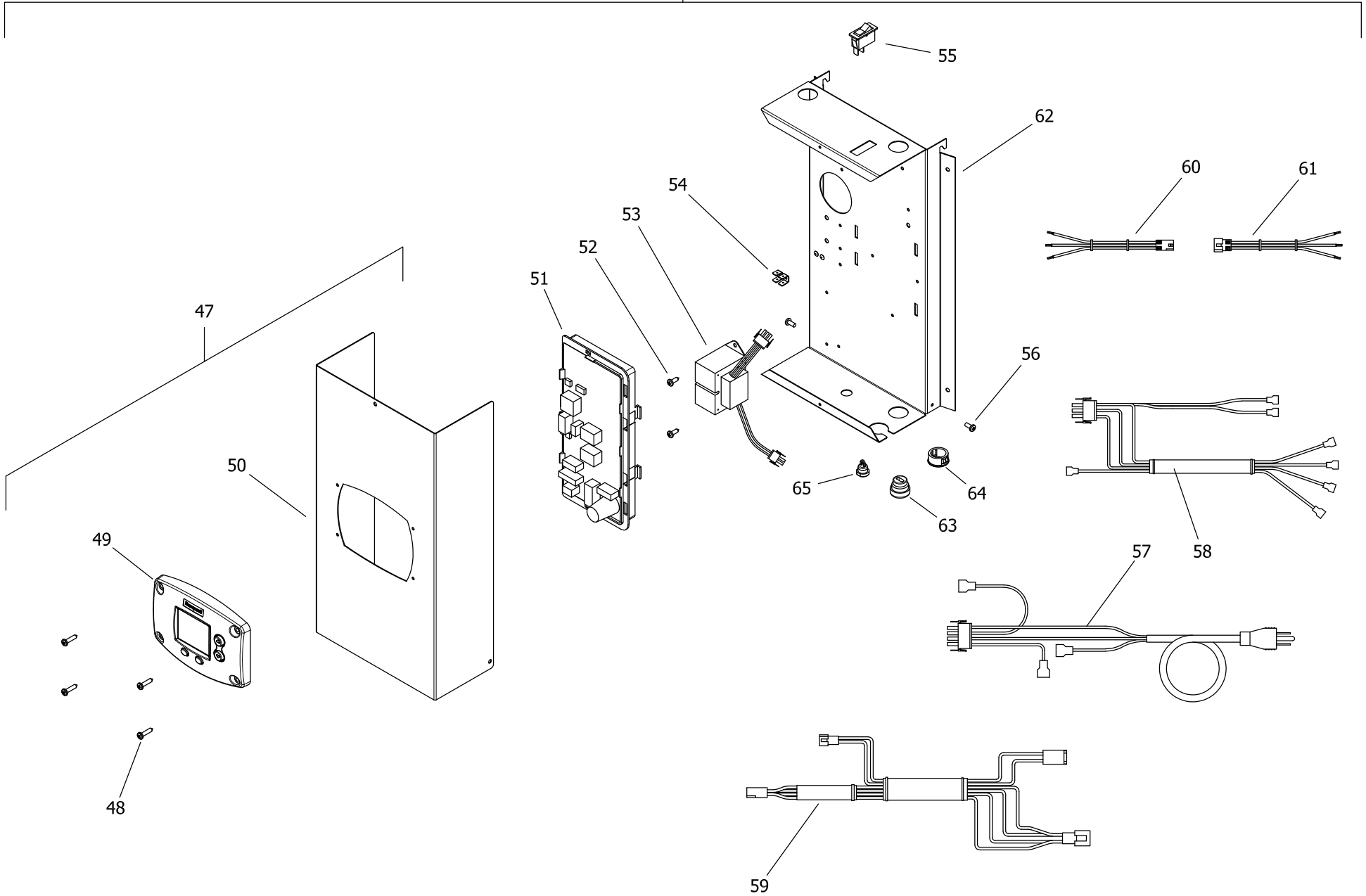

Item	Description	Model	Model	Model	Model
		D38T155(E)*(N,X)	D65T370(E)*(N,X)(A)	D65T399(E)*N(A)	D75T125(E)*(N,X)
21	Control Box Assembly (Dual Sensor)	---	243-46560-01	243-46560-01	---
	Control Box Assembly (Single Sensor)	243-46614-01	---	---	243-46614-02
47	Control Box Cover Assembly	243-46615-01	243-46615-01	243-46615-01	243-46615-01
48	Screw #8-18 X 3/4 Pan Head CR	239-43863-00	239-43863-00	239-43863-00	239-43863-00
49	Resideo Temperature Contol Display	233-46557-00	233-46557-00	233-46557-00	233-46557-00
50	Control Box Cover	239-46509-00	239-46509-00	239-46509-00	239-46509-00
51	Integrated Control Board (Dual Sensor)	---	233-46616-00	233-46616-00	---
	Integrated Control Board (Single Sensor)	233-47260-00	---	---	233-47260-00
52	Screw #8-18 X 1/2 Pan Head CR	239-43736-00	239-43736-00	239-43736-00	239-43736-00
53	Transformer 110V	415-44072-01	415-44072-01	415-44072-01	415-44072-01
54	Ground Lug 1/4 x .032	239-80112-00	239-80112-00	239-80112-00	239-80112-00
55	Power On/Off Switch	239-49391-00	239-49391-00	239-49391-00	239-49391-00
56	Screw 8/32 X 1/4 Pan Head CR w/adh.	239-46522-00	239-46522-00	239-46522-00	239-46522-00
57	Primary Transformer Wiring Harness	239-46531-00	239-46531-00	239-46531-00	239-46531-00
58	Secondary Transformer Wiring Harness	239-46530-00	239-46530-00	239-46530-00	239-46530-00
59	Power Cord Wiring Harness	239-46533-00	239-46533-00	239-46533-00	239-46533-00
60	Gas Valve Control Wiring Harness	239-46529-01	239-46529-01	239-46529-01	239-46529-01
61	Damper Wiring Harness (Dual Sensor)	---	239-46526-04	239-46526-04	---
	Damper Wiring Harness (Single Sensor)	239-46527-01	---	---	239-46527-03
62	Display Control Wiring Harness	239-46944-00	239-46944-00	239-46944-00	239-46944-00
63	Display Cover Wiring Harness	239-46617-00	239-46617-00	239-46617-00	239-46617-00
64	Control Box Panel	239-46508-00	239-46508-00	239-46508-00	239-46508-00
65	Strain Relief Bushing 7/8"	239-80372-00	239-80372-00	239-80372-00	239-80372-00
66	Snap-in Bushing 7/8"	239-80406-00	239-80406-00	239-80406-00	239-80406-00
67	Strain Relief Bushing 1/2"	239-44575-00	239-44575-00	239-44575-00	239-44575-00

* Applies to all warranties

** Ordering a complete burner rack may increase delivery time. Please order the specific component required for the quickest delivery.

*** No LP version model available.

**** No Low Nox versions available over 400K btuh.

Anode may need to be cut to length. See page 32.

▲ Applies when "E" is present in model number (Example: D38T155E3N).

¹ For serial numbers PRIOR to GB13067706.

² For serial numbers AFTER and including GB13067706.

³ For serial numbers PRIOR to HA14465923.

⁴ For serial numbers including and AFTER HA14465923

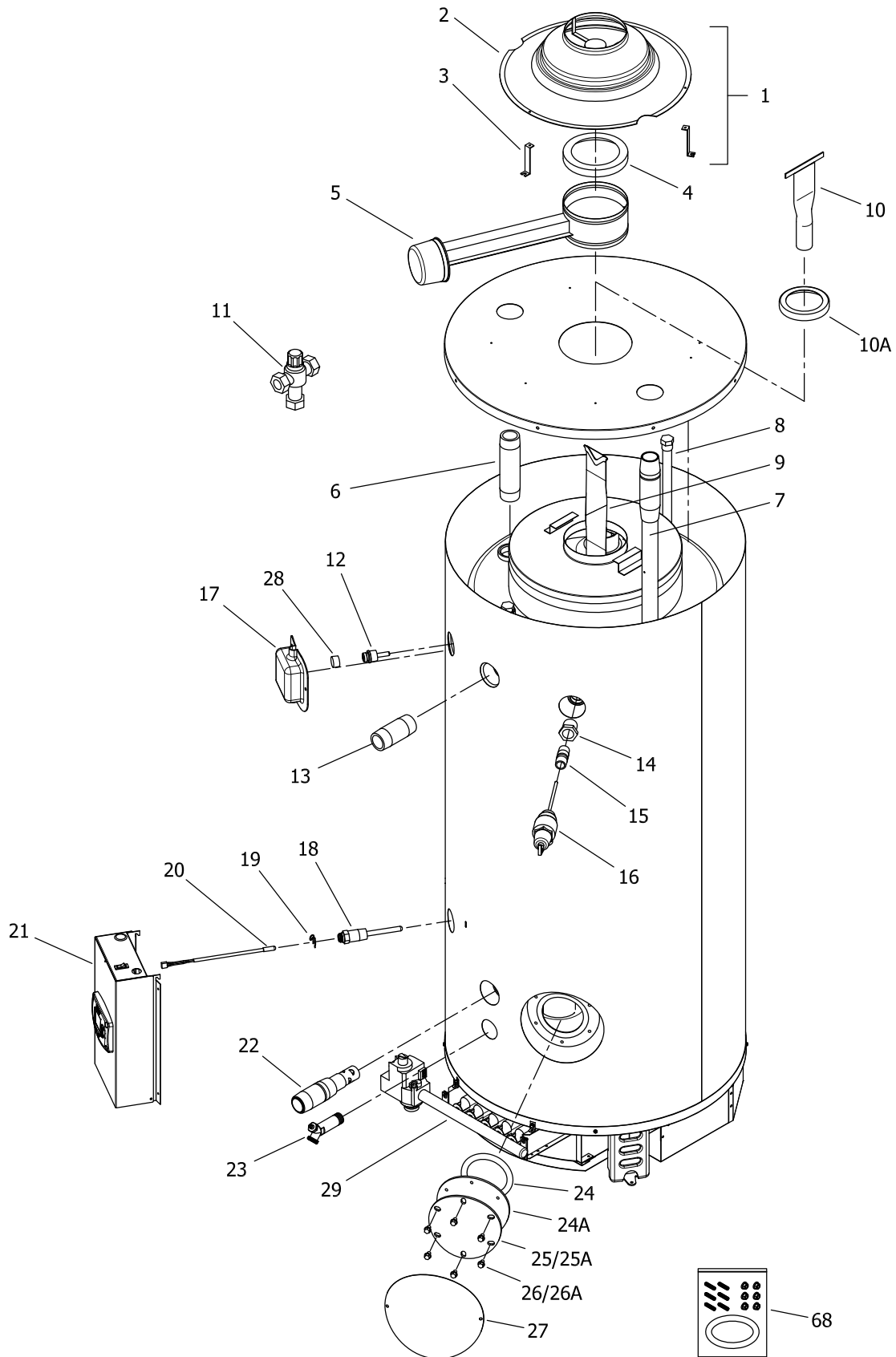

Item	Description	Model	Model	Model	Model	Model
		D75T160(E)*(N,X)	D75T300*(N,X)(A)	D80L399(E)*(N,X)(A)	D80L450*(N,X)(A)	D80L505*(N,X)(A)
1	Draft Diverter Complete with Leg Kit	265-46543-00	265-46545-00	265-46551-00	265-46552-00	265-46552-00
2	Draft Diverter Only	239-81998-00-01	239-81502-00-01	239-81779-00-01	239-81739-00-01	239-81739-00-01
3	Draft Diverter Leg Kit Only	243-43690-06	243-43690-04	243-43690-07	243-43690-05	243-43690-05
4	Flue Damper Reducer	239-81980-00	---	239-81812-00	---	---
5	Flue Damper Complete	265-43112-00	415-42974-00	415-43114-00	415-42975-00	415-42975-00
6	Hot Water Outlet Nipple (Top)	229-40913-01	---	---	---	---
7	Cold Water Inlet Diptube (Top)	415-46709-01	---	---	---	---
8	Plug Type Anode Rod (Magnesium)#	224-47782-06 (Qty. 2)	224-47782-06 (Qty. 3)	224-47782-10 (Qty. 4)	224-47782-10 (Qty. 4)	224-47782-10 (Qty. 4)
	Plug Type Anode Rod (Aluminum)#	224-38508-06 (Qty. 2)	224-38508-06 (Qty. 3)	224-38508-05 (Qty. 4)	224-38508-05 (Qty. 4)	224-38508-05 (Qty. 4)
	Plug Type Anode Rod (A420 Aluminum)#	224-49559-04 (Qty. 2)	224-49559-04 (Qty. 3)	224-49559-04 (Qty. 4)	224-49559-04 (Qty. 4)	224-49559-04 (Qty. 4)
9	Flue Baffle	---	243-82076-00 (Qty. 11)	243-81747-00 (Qty. 20)	243-81730-00 (Qty. 20)	243-81747-00 (Qty. 20)
10	Flue Core	---	---	---	---	---
10A	Flue Reducer	243-54363-00 (Qty. 2)	---	---	---	---
11	ASSE Approved Mixing Valve (Optional)	239-51778-00	239-51778-00	239-51778-00	239-51778-00	239-51778-00
12	Upper Thermostat Sensor	---	415-82033-00	415-82033-00	415-82033-00	415-82033-00
13	Hot Water Outlet Nipple (Side)	229-40913-02	229-40913-02	229-40913-02	229-40913-02	229-40913-02
14	1" NPT to 3/4" NPT Reducer Bushing	---	---	---	---	---
15	3/4" NPT Nipple	229-32762-04	---	---	---	---
	1" NPT Nipple	---	229-32762-19	239-80982-00	239-80982-00	239-80982-00
16	T&P Valve	415-30246-00	415-33630-04	415-33630-04	415-33630-04	415-33630-04
17	Utility Cover	239-80281-03	239-80281-03	239-80281-03	239-80281-03	239-80281-03
18	Lower Thermostat Well	233-46558-02	233-46558-02	233-46558-01	233-46558-01	233-46558-01
19	Clip for Lower Thermostat	233-45242-00	233-45242-00	233-45242-00	233-45242-00	233-45242-00
20	Lower Thermostat Sensor	415-46553-02	415-46553-02	415-46553-01	415-46553-01	415-46553-01
21	Control Box Assembly	243-46614-02	243-46560-01	243-46560-01	243-46560-01	243-46560-01
22	Cold Water Inlet Diptube (Side)	415-44731-00	415-44731-00	415-44731-00	415-44731-00	415-44731-00
23	Brass Drain Valve	415-42351-04	415-42351-04	415-42351-04	415-42351-04	415-42351-04
24	Cleanout O-Ring Gasket	205-18427-00	205-18427-00	205-18427-00	205-18427-00	205-18427-00
24A	Cleanout Gasket (ASME)	---	205-32942-00	205-32942-00	205-32942-00	205-32942-00
25	Cleanout Cover	205-18428-00	205-18428-00	205-18428-00	205-18428-00	205-18428-00
25A	Cleanout Cover (ASME)	---	205-32941-00	205-32941-00	205-32941-00	205-32941-00
26	Cleanout Cover Screw	239-82166-00 (Qty. 6)	239-82166-00 (Qty. 6)	239-82166-00 (Qty. 6)	239-82166-00 (Qty. 6)	239-82166-00 (Qty. 6)
26A	Cleanout Cover Screw (ASME)	---	239-32970-00 (Qty. 6)	239-32970-00 (Qty. 6)	239-32970-00 (Qty. 6)	239-32970-00 (Qty. 6)
27	Cleanout Access Cover	243-20299-00	243-20299-00	243-20299-00	243-20299-00	243-20299-00
28	Pipe Plug (3/4 NPT)	---	---	---	---	---
68	Kit-Cleanout (Not For Use With ASME Tanks)	415-54256-00	415-54256-00	415-54256-00	415-54256-00	415-54256-00

* Applies to all warranties

** Ordering a complete burner rack may increase delivery time. Please order the specific component required for the quickest delivery.

*** No LP version model available.

**** No Low Nox versions available over 400K btuh.

Anode may need to be cut to length. See page 32.

▲ Applies when "E" is present in model number (Example: D38T155E3N).

¹ For serial numbers PRIOR to GB13067706.

² For serial numbers AFTER and including GB13067706.

³ For serial numbers PRIOR to HA14465923.

⁴ For serial numbers including and AFTER HA14465923

Item	Description	Model	Model	Model	Model	Model
		D75T160(E)*(N,X)	D75T300*(N,X)(A)	D80L399(E)*(N,X)(A)	D80L450*(N,X)(A)	D80L505*(N,X)(A)
29	Burner Rack Complete (Natural Gas) **	243-39205-03	243-39343-01	243-81788-01	243-81788-03	243-81788-05
	Burner Rack Complete (Nat. Gas)(Lo NOX) **▲	243-42563-01	243-42560-01	243-42562-01	*****	*****
	Burner Rack Complete (LP Gas) **	243-39205-04	243-39343-02	243-81788-02	243-81788-04	243-81788-06
30	Burner Rack Only	233-81969-01	239-81969-02	239-81969-03	239-81969-03	239-81969-03
31	Gas Valve (Natural Gas)	415-80830-02	415-80830-02	415-81608-03	415-81608-03	415-81608-03
	Gas Valve (LP Gas)	415-80831-02	415-80831-02	415-80831-02	415-80831-02	415-80831-02
32	Burner Tube (Standard)	228-39177-00 (Qty. 5)	228-39177-00 (Qty. 7)	228-39177-00 (Qty. 9)	228-39177-00 (Qty. 9)	228-39177-00 (Qty. 9)
	Burner Tube (Lo-NOX) ▲	228-42490-00 (Qty. 5)	228-42490-00 (Qty. 7)	228-42490-00 (Qty. 9)	*****	228-42490-00 (Qty. 9)
33	Burner Manifold (Natural Gas)	233-39170-00	---	---	---	---
	Burner Manifold (LP Gas)	233-39170-00	---	---	---	---
33A	Burner Manifold (Natural Gas)	---	233-39172-00	---	---	---
	Burner Manifold (LP Gas)	---	233-39172-00	233-39173-00	233-39173-00	233-39173-00
33B	Burner Manifold (Natural Gas)	---	---	233-39171-00	233-39171-00	233-39171-00
34	Main Burner Orifice (Natural Gas) (0ft to 2000ft)	234-06016-39 (Qty. 5)	234-06016-32 (Qty. 7)	234-06016-32 (Qty. 9)	234-06016-1/8 (Qty. 9)	234-06016-30 (Qty. 9)
	High Altitude (Natural Gas) (2001ft to 5000ft)	234-06016-42 (Qty. 5)	234-06016-36 (Qty. 7)	234-06016-35 (Qty. 9)	234-06016-32 (Qty. 9)	234-06016-1/8 (Qty. 9)
	High Altitude (Natural Gas) (5001ft to 8000ft)	234-06016-43 (Qty. 5)	234-06016-37 (Qty. 7)	234-06016-37 (Qty. 9)	234-06016-34 (Qty. 9)	234-06016-32 (Qty. 9)
	High Altitude (Natural Gas) (8001ft & above)	234-06016-44 (Qty. 5)	234-06016-38 (Qty. 7)	234-06016-38 (Qty. 9)	234-06016-35 (Qty. 9)	234-06016-32 (Qty. 9)
	Main Burner Orifice (LP Gas) (0ft to 2000ft)	234-06016-52 (Qty. 5)	234-06016-48 (Qty. 7)	234-06016-48 (Qty. 9)	234-06016-46 (Qty. 9)	234-06016-44 (Qty. 9)
	High Altitude (LP Gas) (2001ft to 5000ft)	234-06016-1/16 (Qty. 5)	234-06016-50 (Qty. 7)	234-06016-50 (Qty. 9)	234-06016-48 (Qty. 9)	234-06016-45 (Qty. 9)
	High Altitude (LP Gas) (5001ft to 8000ft)	234-06016-53 (Qty. 5)	234-06016-51 (Qty. 7)	234-06016-51 (Qty. 9)	234-06016-49 (Qty. 9)	234-06016-47 (Qty. 9)
	High Altitude (LP Gas) (8001ft & above)	234-06016-53 (Qty. 5)	234-06016-51 (Qty. 7)	234-06016-51 (Qty. 9)	234-06016-49 (Qty. 9)	234-06016-48 (Qty. 9)
35	Pilot Shield	239-41333-00	239-41333-00	239-41333-00	239-41333-00	239-41333-00
36	Pilot Assembly (Natural Gas)	415-41323-01	415-41323-01	415-41323-01	415-41323-01	415-41323-01
	Pilot Assembly (LP Gas)	233-41323-02	233-41323-02	233-41323-02	233-41323-02	233-41323-02
37	Pilot Orifice (Natural Gas)	233-41606-01	233-41606-01	233-41606-01	233-41606-01	233-41606-01
	Pilot Orifice (LP Gas)	233-41606-02	233-41606-02	233-41606-02	233-41606-02	233-41606-02
38	Aluminum Pilot Tube	233-80361-01	233-80361-01	233-80361-01	233-80361-01	233-80361-01
39	Burner Support	239-45180-00	239-45181-00	239-39259-00	239-39259-00	239-39259-00
40	Draft Panel	239-39419-00	239-39420-00	239-39421-00	239-39421-00	239-39421-00
41	Pilot Mounting Screw	239-11706-00 (Qty. 2)	239-11706-00 (Qty. 2)	239-11706-00 (Qty. 2)	239-11706-00 (Qty. 2)	239-11706-00 (Qty. 2)
42	Sreet Elbow 1" NPT (Natural)	---	---	239-19636-00	239-19636-00	239-19636-00
43	Pipe Nipple 1" NPT (Natural)	---	---	239-81595-00	239-81595-00	239-81595-00
44	Elbow 1" NPT (Natural)	---	---	239-19637-00	239-19637-00	239-19637-00
45	Gas Support Bracket (Natural)	---	---	239-44517-00	239-44517-00	239-44517-00
	Gas Support Bracket (LP)	---	239-81816-03	239-81816-02	239-81816-02	239-81816-02
46	Ground Wire	239-38951-52	239-38951-52	239-38951-52	239-38951-52	239-38951-52
-	LP to Natural Gas Conversion Kit	265-46033-03	265-46033-04	265-46034-06	265-46034-07	265-46034-08

* Applies to all warranties

** Ordering a complete burner rack may increase delivery time. Please order the specific component required for the quickest delivery.

*** No LP version model available.

**** No Low Nox versions available over 400K btuh.

Anode may need to be cut to length. See page 32.

▲ Applies when "E" is present in model number (Example: D38T155E3N).

¹ For serial numbers PRIOR to GB13067706.

² For serial numbers AFTER and including GB13067706.

³ For serial numbers PRIOR to HA14465923.

⁴ For serial numbers including and AFTER HA14465923

Item	Description	Model	Model	Model	Model	Model
		D75T160(E)*(N,X)	D75T300*(N,X)(A)	D80L399(E)*(N,X)(A)	D80L450*(N,X)(A)	D80L505*(N,X)(A)
21	Control Box Assembly (Dual Sensor)	---	243-46560-01	243-46560-01	243-46560-01	243-46560-01
	Control Box Assembly (Single Sensor)	243-46614-02	---	---	---	---
47	Control Box Cover Assembly	243-46615-01	243-46615-01	243-46615-01	243-46615-01	243-46615-01
48	Screw #8-18 X 3/4 Pan Head CR	239-43863-00	239-43863-00	239-43863-00	239-43863-00	239-43863-00
49	Resideo Temperature Contol Display	233-46557-00	233-46557-00	233-46557-00	233-46557-00	233-46557-00
50	Control Box Cover	239-46509-00	239-46509-00	239-46509-00	239-46509-00	239-46509-00
51	Integrated Control Board (Dual Sensor)	---	233-46616-00	233-46616-00	233-46616-00	233-46616-00
	Integrated Control Board (Single Sensor)	233-47260-00	---	---	---	---
52	Screw #8-18 X 1/2 Pan Head CR	239-43736-00	239-43736-00	239-43736-00	239-43736-00	239-43736-00
53	Transformer 110V	415-44072-01	415-44072-01	415-44072-01	415-44072-01	415-44072-01
54	Ground Lug 1/4 x .032	239-80112-00	239-80112-00	239-80112-00	239-80112-00	239-80112-00
55	Power On/Off Switch	239-49391-00	239-49391-00	239-49391-00	239-49391-00	239-49391-00
56	Screw 8/32 X 1/4 Pan Head CR w/adh.	239-46522-00	239-46522-00	239-46522-00	239-46522-00	239-46522-00
57	Primary Transformer Wiring Harness	239-46531-00	239-46531-00	239-46531-00	239-46531-00	239-46531-00
58	Secondary Transformer Wiring Harness	239-46530-00	239-46530-00	239-46530-00	239-46530-00	239-46530-00
59	Power Cord Wiring Harness	239-46533-00	239-46533-00	239-46533-00	239-46533-00	239-46533-00
60	Gas Valve Control Wiring Harness	239-46529-01	239-46529-01	239-46529-01	239-46529-01	239-46529-01
61	Damper Wiring Harness (Dual Sensor)	---	239-46526-04	239-46526-04	239-46526-04	239-46526-04
	Damper Wiring Harness (Single Sensor)	239-46527-03	---	---	---	---
62	Display Control Wiring Harness	239-46944-00	239-46944-00	239-46944-00	239-46944-00	239-46944-00
63	Display Cover Wiring Harness	239-46617-00	239-46617-00	239-46617-00	239-46617-00	239-46617-00
64	Control Box Panel	239-46508-00	239-46508-00	239-46508-00	239-46508-00	239-46508-00
65	Strain Relief Bushing 7/8"	239-80372-00	239-80372-00	239-80372-00	239-80372-00	239-80372-00
66	Snap-in Bushing 7/8"	239-80406-00	239-80406-00	239-80406-00	239-80406-00	239-80406-00
67	Strain Relief Bushing 1/2"	239-44575-00	239-44575-00	239-44575-00	239-44575-00	239-44575-00

* Applies to all warranties

** Ordering a complete burner rack may increase delivery time. Please order the specific component required for the quickest delivery.

*** No LP version model available.

**** No Low Nox versions available over 400K btuh.

Anode may need to be cut to length. See page 32.

▲ Applies when "E" is present in model number (Example: D38T155E3N).

¹ For serial numbers PRIOR to GB13067706.

² For serial numbers AFTER and including GB13067706.

³ For serial numbers PRIOR to HA14465923.

⁴ For serial numbers including and AFTER HA14465923

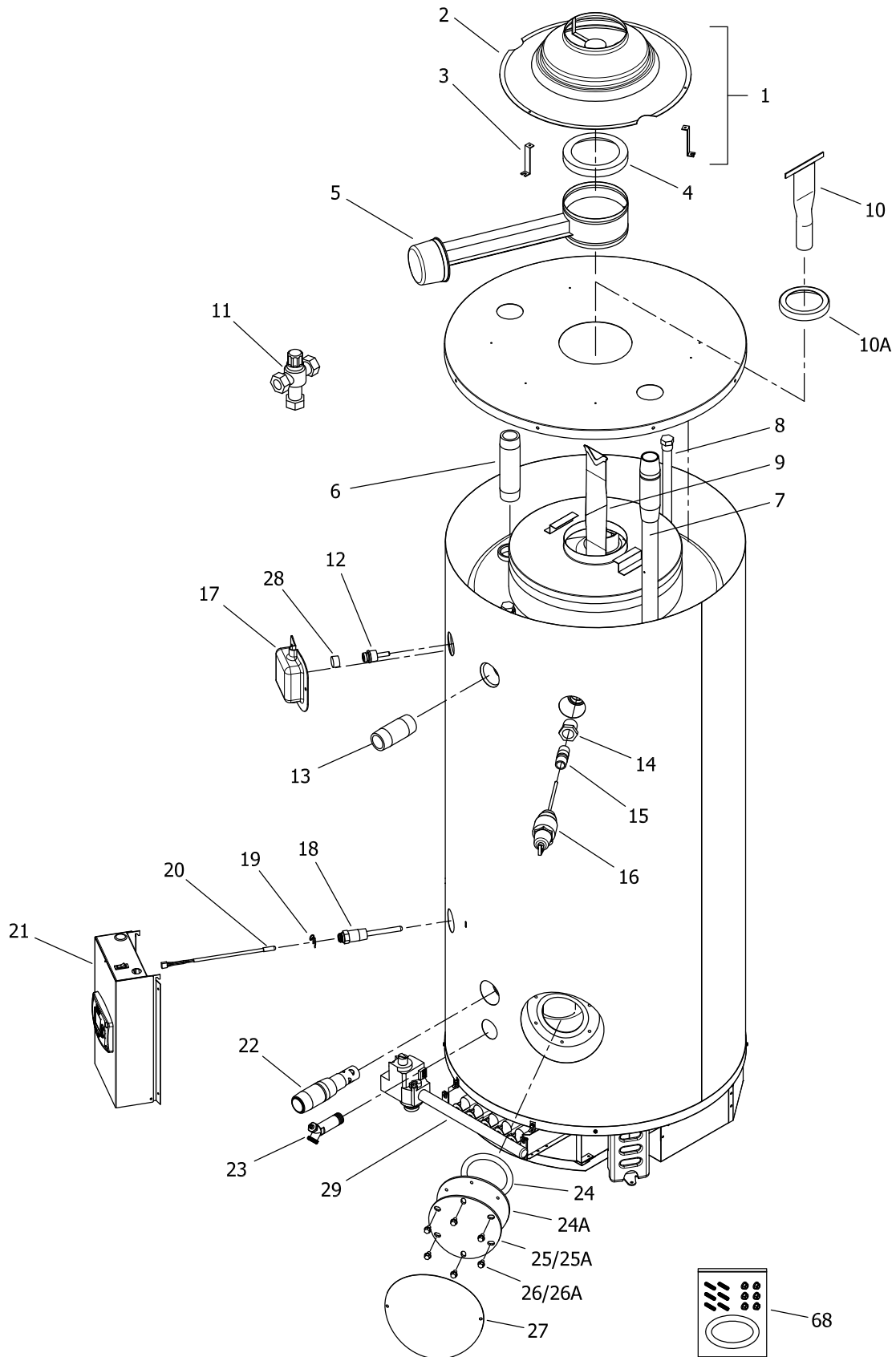

Item	Description	Model	Model	Model	Model	Model
		D80T180(E)*(N,X)	D80T199(E)*(N,X)	D80T250(E)*(N,X)(A)	D80T425*(N,X)(A)	D80T505*(N,X)(A)
1	Draft Diverter Complete with Leg Kit	265-46544-00	265-46544-00	265-46544-00	265-46547-00	265-46547-00
2	Draft Diverter Only	239-81986-00-01	239-81986-00-01	239-81986-00-01	239-82005-02-01	239-82005-02-01
3	Draft Diverter Leg Kit Only	243-43690-02	243-43690-02	243-43690-02	243-43690-01	243-43690-01
4	Flue Damper Reducer	---	---	---	---	---
5	Flue Damper Complete	415-42973-00	415-42973-00	415-42973-00	415-42975-00	415-42975-00
6	Hot Water Outlet Nipple (Top)	229-40913-01	229-40913-01	229-40913-01	---	---
7	Cold Water Inlet Diptube (Top)	415-46709-03	415-46709-03	415-46709-03	---	---
8	Plug Type Anode Rod (Magnesium)#	224-47782-11 (Qty. 2)	224-47782-11 (Qty. 2)	224-47782-11 (Qty. 2)	224-47782-12 (Qty. 3)	224-47782-12 (Qty. 3)
	Plug Type Anode Rod (Aluminum)#	224-38508-07 (Qty. 2)	224-38508-07 (Qty. 2)	224-38508-07 (Qty. 2)	224-38508-08 (Qty. 3)	224-38508-08 (Qty. 3)
	Plug Type Anode Rod (A420 Aluminum)#	224-49559-04 (Qty. 2)	224-49559-04 (Qty. 2)	224-49559-04 (Qty. 2)	224-49559-04 (Qty. 3)	224-49559-04 (Qty. 3)
9	Flue Baffle	243-81563-00 (Qty. 8)	243-82118-00 (Qty. 8)	243-82117-00 (Qty. 8)	243-39327-00 (Qty. 16)	243-81501-00 (Qty. 16)
10	Flue Core	---	---	---	---	---
10A	Flue Reducer	---	---	---	---	---
11	ASSE Approved Mixing Valve (Optional)	239-51778-00	239-51778-00	239-51778-00	239-51778-00	239-51778-00
12	Upper Thermostat Sensor	415-82033-00	415-82033-00	415-82033-00	415-82033-00	415-82033-00
13	Hot Water Outlet Nipple (Side)	229-40913-02	229-40913-02	229-40913-02	229-40913-02	229-40913-02
14	1" NPT to 3/4" NPT Reducer Bushing	239-02052-00	239-02052-00	---	---	---
15	3/4" NPT Nipple	229-32762-04	229-32762-04	---	---	---
	1" NPT Nipple	---	---	229-32762-19	229-32762-19	229-32762-19
16	T&P Valve	415-30246-00	415-30246-00	415-33630-04	415-33630-04	415-33630-04
17	Utility Cover	239-80281-03	239-80281-03	239-80281-03	239-80281-03	239-80281-03
18	Lower Thermostat Well	233-46558-02	233-46558-02	233-46558-02	233-46558-02	233-46558-02
19	Clip for Lower Thermostat	233-45242-00	233-45242-00	233-45242-00	233-45242-00	233-45242-00
20	Lower Thermostat Sensor	415-46553-01	415-46553-01	415-46553-01	415-46553-02	415-46553-02
21	Control Box Assembly	243-46560-03	243-46560-03	243-46560-03	243-46560-02	243-46560-02
22	Cold Water Inlet Diptube (Side)	415-44731-00	415-44731-00	415-44731-00	415-44731-00	415-44731-00
23	Brass Drain Valve	415-42351-04	415-42351-04	415-42351-04	415-42351-04	415-42351-04
24	Cleanout O-Ring Gasket	205-18427-00	205-18427-00	205-18427-00	205-18427-00	205-18427-00
24A	Cleanout Gasket (ASME)	---	---	205-32942-00	205-32942-00	205-32942-00
25	Cleanout Cover	205-18428-00	205-18428-00	205-18428-00	205-18428-00	205-18428-00
25A	Cleanout Cover (ASME)	---	---	205-32941-00	205-32941-00	205-32941-00
26	Cleanout Cover Screw	239-82166-00 (Qty. 6)	239-82166-00 (Qty. 6)	239-82166-00 (Qty. 6)	239-82166-00 (Qty. 6)	239-82166-00 (Qty. 6)
26A	Cleanout Cover Screw (ASME)	---	---	239-32970-00 (Qty. 6)	239-32970-00 (Qty. 6)	239-32970-00 (Qty. 6)
27	Cleanout Access Cover	243-20299-00	243-20299-00	243-20299-00	243-20299-00	243-20299-00
28	Pipe Plug (3/4 NPT)	---	---	---	---	---
68	Kit-Cleanout (Not For Use With ASME Tanks)	415-54256-00	415-54256-00	415-54256-00	415-54256-00	415-54256-00

* Applies to all warranties

** Ordering a complete burner rack may increase delivery time. Please order the specific component required for the quickest delivery.

*** No LP version model available.

**** No Low Nox versions available over 400K btuh.

Anode may need to be cut to length. See page 32.

▲ Applies when "E" is present in model number (Example: D38T155E3N).

¹ For serial numbers PRIOR to GB13067706.

² For serial numbers AFTER and including GB13067706.

³ For serial numbers PRIOR to HA14465923.

⁴ For serial numbers including and AFTER HA14465923

29

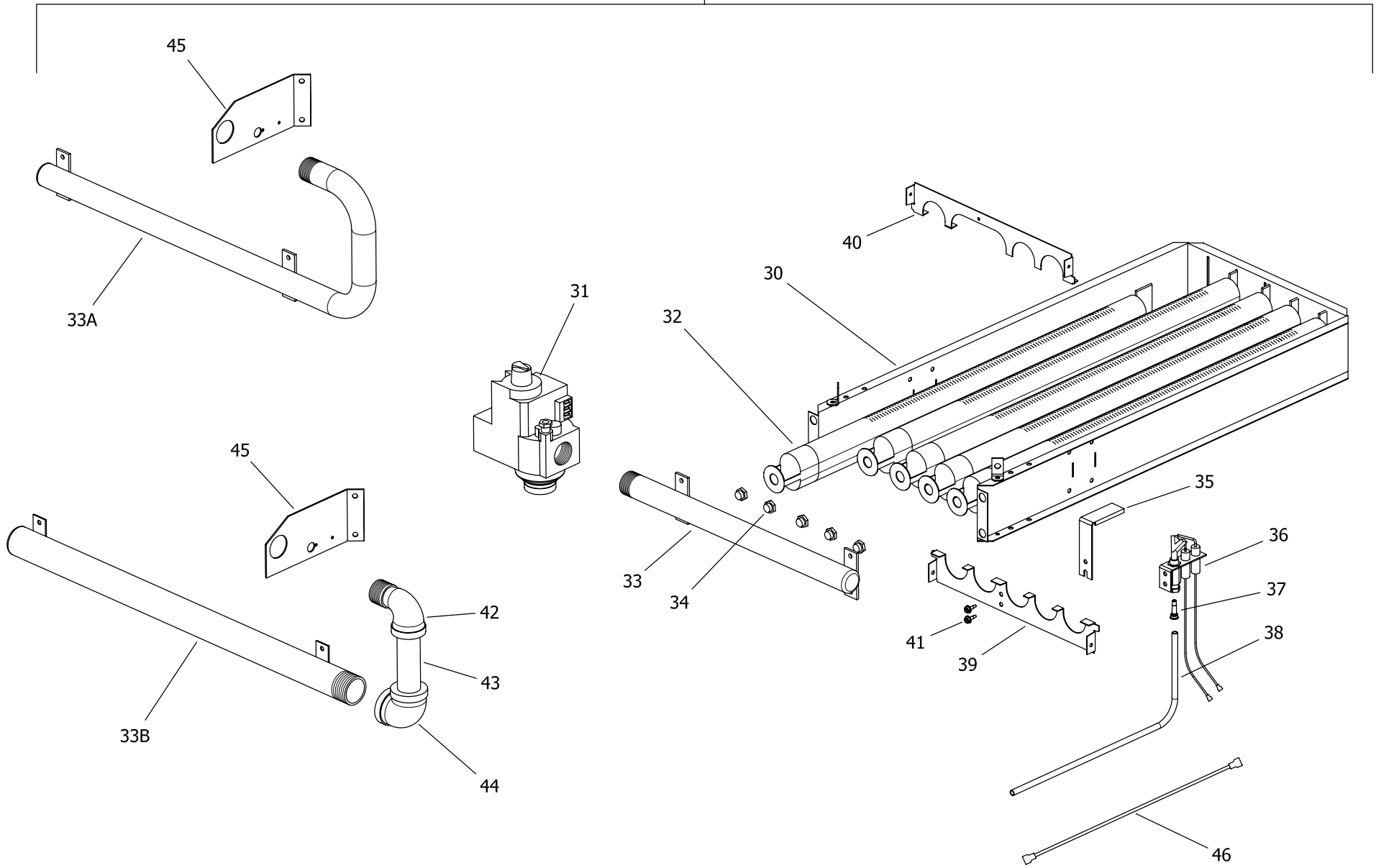

Item	Description	Model	Model	Model	Model	Model
		D80T180(E)*(N,X)	D80T199(E)*(N,X)	D80T250(E)*(N,X)(A)	D80T425*(N,X)(A)	D80T505*(N,X)(A)
29	Burner Rack Complete (Natural Gas) **	243-39205-07	243-39205-05	243-81743-03	243-39322-05	243-39322-13
	Burner Rack Complete (Nat. Gas)(Lo NOX) **▲	243-42563-03	243-42563-02	243-42536-02	****	****
	Burner Rack Complete (LP Gas) **	243-39205-08	243-39205-06	243-81743-06	243-39322-06	243-39322-14
30	Burner Rack Only	233-81969-01	233-81969-01	239-81969-02	239-81969-03	239-81969-03
31	Gas Valve (Natural Gas)	415-80830-02	415-80830-02	415-80830-02	415-81608-03	415-81608-03
	Gas Valve (LP Gas)	415-80831-02	415-80831-02	415-80831-02	415-80831-02	415-81608-04
32	Burner Tube (Standard)	228-39177-00 (Qty. 5)	228-39177-00 (Qty. 5)	228-39177-00 (Qty. 7)	228-39177-00 (Qty. 9)	228-39177-00 (Qty. 9)
	Burner Tube (Lo-NOX) ▲	228-42490-00 (Qty. 5)	228-42490-00 (Qty. 5)	228-42490-00 (Qty. 7)	****	****
33	Burner Manifold (Natural Gas)	233-39170-00	233-39170-00	233-81725-00	---	---
	Burner Manifold (LP Gas)	233-39170-00	233-39170-00	233-81725-00	---	---
33A	Burner Manifold (Natural Gas)	---	---	---	---	---
	Burner Manifold (LP Gas)	---	---	---	233-39173-00	233-39173-00
33B	Burner Manifold (Natural Gas)	---	---	---	233-39171-00	233-39171-00
34	Main Burner Orifice (Natural Gas) (0ft to 2000ft)	234-06016-37 (Qty. 5)	234-06016-35 (Qty. 5)	234-06016-37 (Qty. 7)	234-06016-32 (Qty. 9)	234-06016-30 (Qty. 9)
	High Altitude (Natural Gas) (2001ft to 5000ft)	234-06016-39 (Qty. 5)	234-06016-37 (Qty. 5)	234-06016-40 (Qty. 7)	234-06016-33 (Qty. 9)	234-06016-1/8 (Qty. 9)
	High Altitude (Natural Gas) (5001ft to 8000ft)	234-06016-42 (Qty. 5)	234-06016-39 (Qty. 5)	234-06016-42 (Qty. 7)	234-06016-36 (Qty. 9)	234-06016-32 (Qty. 9)
	High Altitude (Natural Gas) (8001ft & above)	234-06016-42 (Qty. 5)	234-06016-40 (Qty. 5)	234-06016-42 (Qty. 7)	234-06016-36 (Qty. 9)	234-06016-32 (Qty. 9)
	Main Burner Orifice (LP Gas) (0ft to 2000ft)	234-06016-50 (Qty. 5)	234-06016-49 (Qty. 5)	234-06016-50 (Qty. 7)	234-06016-46 (Qty. 9)	234-06016-45 (Qty. 9)
	High Altitude (LP Gas) (2001ft to 5000ft)	234-06016-51 (Qty. 5)	234-06016-50 (Qty. 5)	234-06016-52 (Qty. 7)	234-06016-48 (Qty. 9)	234-06016-46 (Qty. 9)
	High Altitude (LP Gas) (5001ft to 8000ft)	234-06016-1/16 (Qty. 5)	234-06016-51 (Qty. 5)	234-06016-1/16 (Qty. 7)	234-06016-49 (Qty. 9)	234-06016-47 (Qty. 9)
	High Altitude (LP Gas) (8001ft & above)	234-06016-1/16 (Qty. 5)	234-06016-52 (Qty. 5)	234-06016-53 (Qty. 7)	234-06016-50 (Qty. 9)	234-06016-48 (Qty. 9)
35	Pilot Shield	239-41333-00	239-41333-00	239-41333-00	239-41333-00	239-41333-00
36	Pilot Assembly (Natural Gas)	415-41323-01	415-41323-01	415-41323-01	415-41323-01	415-41323-01
	Pilot Assembly (LP Gas)	233-41323-02	233-41323-02	233-41323-02	233-41323-02	233-41323-02
37	Pilot Orifice (Natural Gas)	233-41606-01	233-41606-01	233-41606-01	233-41606-01	233-41606-01
	Pilot Orifice (LP Gas)	233-41606-02	233-41606-02	233-41606-02	233-41606-02	233-41606-02
38	Aluminum Pilot Tube	233-80361-01	233-80361-01	233-80361-01	233-80361-01	233-80361-01
39	Burner Support	239-45180-00	239-45180-00	239-45181-00	239-39259-00	239-39259-00
40	Draft Panel	239-39419-00	239-39419-00	239-39420-00	239-39421-00	239-39421-00
41	Pilot Mounting Screw	239-11706-00 (Qty. 2)	239-11706-00 (Qty. 2)	239-11706-00 (Qty. 2)	239-11706-00 (Qty. 2)	239-11706-00 (Qty. 2)
42	Sreet Elbow 1" NPT (Natural)	---	---	---	239-19636-00	239-19636-00
43	Pipe Nipple 1" NPT (Natural)	---	---	---	239-81595-00	239-81595-00
44	Elbow 1" NPT (Natural)	---	---	---	239-19637-00	239-19637-00
45	Gas Support Bracket (Natural)	---	---	---	239-81816-01	239-81816-01
	Gas Support Bracket (LP)	---	---	---	239-81816-02	239-81816-02
46	Ground Wire	239-38951-52	239-38951-52	239-38951-52	239-38951-52	239-38951-52
-	LP to Natural Gas Conversion Kit	265-46033-05	265-46033-06	265-46033-07	265-46034-03	265-46034-04

* Applies to all warranties

** Ordering a complete burner rack may increase delivery time. Please order the specific component required for the quickest delivery.

*** No LP version model available.

**** No Low Nox versions available over 400K btuh.

Anode may need to be cut to length. See page 32.

▲ Applies when "E" is present in model number (Example: D38T155E3N).

¹ For serial numbers PRIOR to GB13067706.

² For serial numbers AFTER and including GB13067706.

³ For serial numbers PRIOR to HA14465923.

⁴ For serial numbers including and AFTER HA14465923

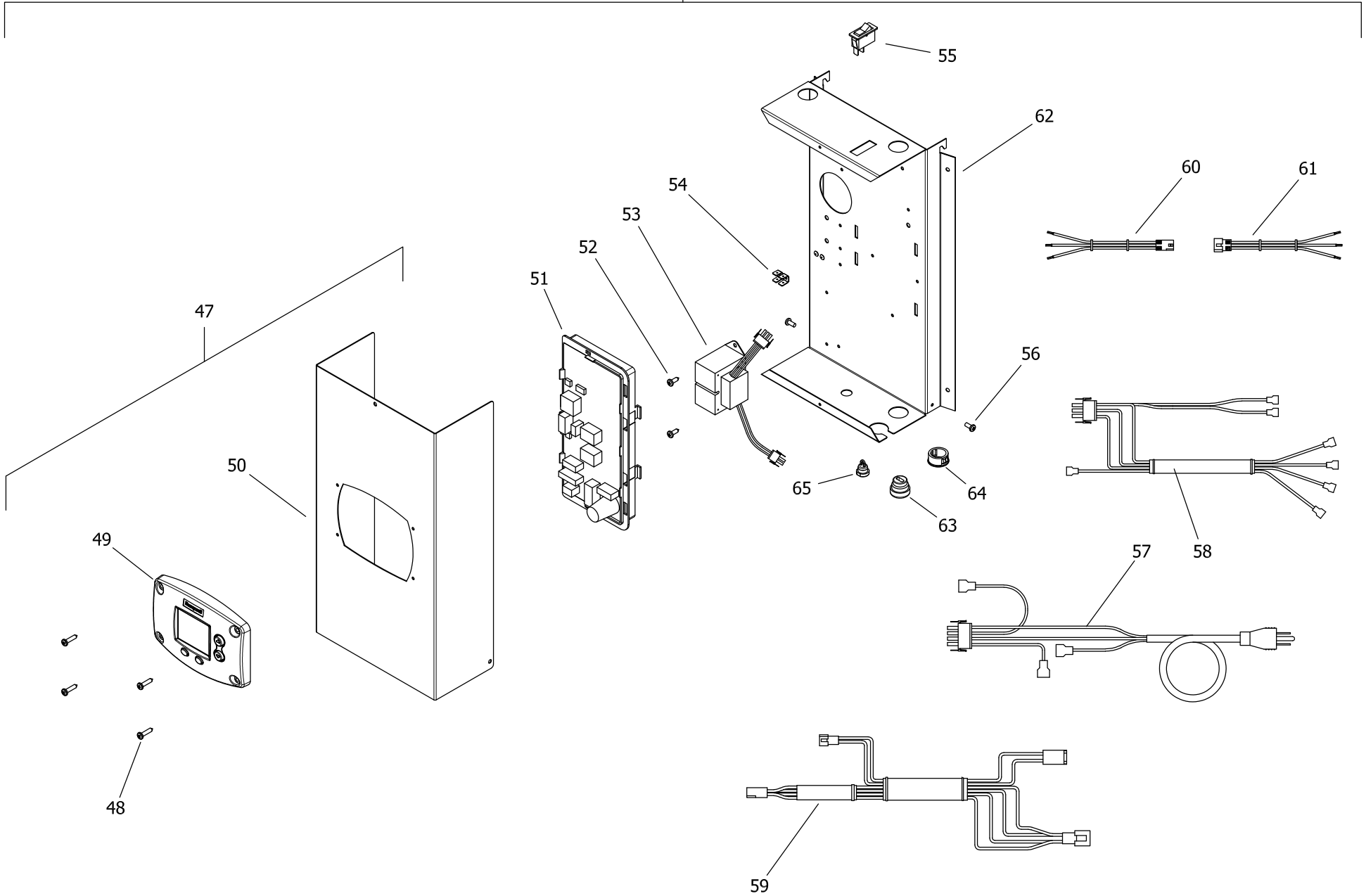

Item	Description	Model	Model	Model	Model	Model
		D80T180(E)*(N,X)	D80T199(E)*(N,X)	D80T250(E)*(N,X)(A)	D80T425*(N,X)(A)	D80T505*(N,X)(A)
21	Control Box Assembly (Dual Sensor)	243-46560-03	243-46560-03	243-46560-03	243-46560-02	243-46560-02
	Control Box Assembly (Single Sensor)	---	---	---	---	---
47	Control Box Cover Assembly	243-46615-01	243-46615-01	243-46615-01	243-46615-01	243-46615-01
48	Screw #8-18 X 3/4 Pan Head CR	239-43863-00	239-43863-00	239-43863-00	239-43863-00	239-43863-00
49	Resideo Temperature Control Display	233-46557-00	233-46557-00	233-46557-00	233-46557-00	233-46557-00
50	Control Box Cover	239-46509-00	239-46509-00	239-46509-00	239-46509-00	239-46509-00
51	Integrated Control Board (Dual Sensor)	233-46616-00	233-46616-00	233-46616-00	233-46616-00	233-46616-00
	Integrated Control Board (Single Sensor)	---	---	---	---	---
52	Screw #8-18 X 1/2 Pan Head CR	239-43736-00	239-43736-00	239-43736-00	239-43736-00	239-43736-00
53	Transformer 110V	415-44072-01	415-44072-01	415-44072-01	415-44072-01	415-44072-01
54	Ground Lug 1/4 x .032	239-80112-00	239-80112-00	239-80112-00	239-80112-00	239-80112-00
55	Power On/Off Switch	239-49391-00	239-49391-00	239-49391-00	239-49391-00	239-49391-00
56	Screw 8/32 X 1/4 Pan Head CR w/adh.	239-46522-00	239-46522-00	239-46522-00	239-46522-00	239-46522-00
57	Primary Transformer Wiring Harness	239-46531-00	239-46531-00	239-46531-00	239-46531-00	239-46531-00
58	Secondary Transformer Wiring Harness	239-46530-00	239-46530-00	239-46530-00	239-46530-00	239-46530-00
59	Power Cord Wiring Harness	239-46533-00	239-46533-00	239-46533-00	239-46533-00	239-46533-00
60	Gas Valve Control Wiring Harness	239-46529-01	239-46529-01	239-46529-01	239-46529-02	239-46529-02
61	Damper Wiring Harness (Dual Sensor)	239-46526-02	239-46526-02	239-46526-02	239-46526-02	239-46526-02
	Damper Wiring Harness (Single Sensor)	---	---	---	---	---
62	Display Control Wiring Harness	239-46944-00	239-46944-00	239-46944-00	239-46944-00	239-46944-00
63	Display Cover Wiring Harness	239-46617-00	239-46617-00	239-46617-00	239-46617-00	239-46617-00
64	Control Box Panel	239-46508-00	239-46508-00	239-46508-00	239-46508-00	239-46508-00
65	Strain Relief Bushing 7/8"	239-80372-00	239-80372-00	239-80372-00	239-80372-00	239-80372-00
66	Snap-in Bushing 7/8"	239-80406-00	239-80406-00	239-80406-00	239-80406-00	239-80406-00
67	Strain Relief Bushing 1/2"	239-44575-00	239-44575-00	239-44575-00	239-44575-00	239-44575-00

* Applies to all warranties

** Ordering a complete burner rack may increase delivery time. Please order the specific component required for the quickest delivery.

*** No LP version model available.

**** No Low Nox versions available over 400K btuh.

Anode may need to be cut to length. See page 32.

▲ Applies when "E" is present in model number (Example: D38T155E3N).

¹ For serial numbers PRIOR to GB13067706.

² For serial numbers AFTER and including GB13067706.

³ For serial numbers PRIOR to HA14465923.

⁴ For serial numbers including and AFTER HA14465923

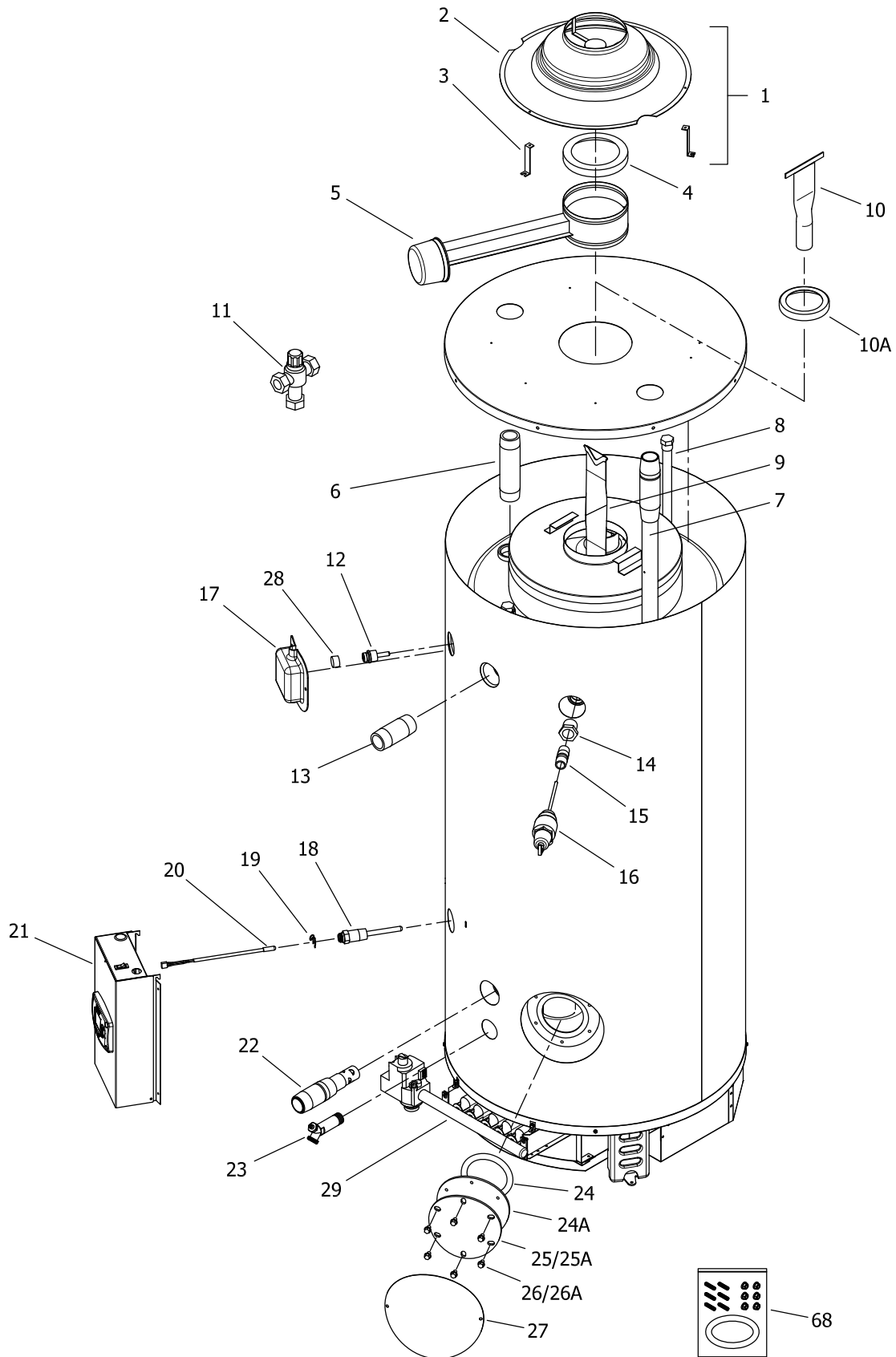

Item	Description	Model	Model	Model	Model
		D100L199(E)*(N,X)	D100L250(E)*(N,X)(A)	D100L270(E)*N(A)	D100L300(E)*(N,X)(A)
1	Draft Diverter Complete with Leg Kit	265-46549-00	265-46549-00	265-46549-00	265-46550-00
2	Draft Diverter Only	239-81733-00-01	239-81733-00-01	239-81733-00-01	239-81502-00-01
3	Draft Diverter Leg Kit Only	243-43690-01	243-43690-01	243-43690-01	243-43690-06
4	Flue Damper Reducer	239-81811-00	239-81811-00	239-81811-00	---
5	Flue Damper Complete	265-43113-00	265-43113-00	265-43113-00	415-42974-00
6	Hot Water Outlet Nipple (Top)	229-40913-01	229-40913-01	229-40913-01	229-40913-01
7	Cold Water Inlet Diptube (Top)	415-46709-01	415-46709-01	415-46709-01	415-46709-01
8	Plug Type Anode Rod (Magnesium)#	224-47782-06 (Qty. 4)	224-47782-06 (Qty. 4)	224-47782-06 (Qty. 4)	224-47782-06 (Qty. 4)
	Plug Type Anode Rod (Aluminum)#	224-38508-06 (Qty. 4)	224-38508-06 (Qty. 4)	224-38508-06 (Qty. 4)	224-38508-06 (Qty. 4)
	Plug Type Anode Rod (A420 Aluminum)#	224-49559-04 (Qty. 4)	224-49559-04 (Qty. 4)	224-49559-04 (Qty. 4)	224-49559-04 (Qty. 4)
9	Flue Baffle	243-81735-00 (Qty. 12)	243-39392-00 (Qty. 12)	243-81796-00 (Qty. 12)	243-81737-00 (Qty. 12)
10	Flue Core	---	---	---	---
10A	Flue Reducer	---	---	---	---
11	ASSE Approved Mixing Valve (Optional)	239-51778-00	239-51778-00	239-51778-00	239-51778-00
12	Upper Thermostat Sensor	415-82033-00 ²	415-82033-00 ²	415-82033-00 ²	415-82033-00 ²
13	Hot Water Outlet Nipple (Side)	229-40913-02	229-40913-02	229-40913-02	229-40913-02
14	1" NPT to 3/4" NPT Reducer Bushing	239-02052-00	---	---	---
15	3/4" NPT Nipple	229-32762-02	---	---	---
	1" NPT Nipple	---	239-80982-00	239-80982-00	239-80982-00
16	T&P Valve	415-30246-00	415-33630-04	415-33630-04	415-33630-04
17	Utility Cover	239-80281-03 ²	239-80281-03 ²	239-80281-03 ²	239-80281-03 ²
18	Lower Thermostat Well	233-46558-01	233-46558-01	233-46558-01	233-46558-01
19	Clip for Lower Thermostat	233-45242-00	233-45242-00	233-45242-00	233-45242-00
20	Lower Thermostat Sensor	415-46553-01	415-46553-01	415-46553-01	415-46553-01
21	Control Box Assembly	243-46614-02	243-46614-02	243-46614-02	243-46614-02
22	Cold Water Inlet Diptube (Side)	415-44731-00	415-44731-00	415-44731-00	415-44731-00
23	Brass Drain Valve	415-42351-02	415-42351-02	415-42351-02	415-42351-02
24	Cleanout O-Ring Gasket	205-18427-00	205-18427-00	205-18427-00	205-18427-00
24A	Cleanout Gasket (ASME)	---	205-32942-00	205-32942-00	205-32942-00
25	Cleanout Cover	205-18428-00	205-18428-00	205-18428-00	205-18428-00
25A	Cleanout Cover (ASME)	---	205-32941-00	205-32941-00	205-32941-00
26	Cleanout Cover Screw	239-82166-00 (Qty. 6)	239-82166-00 (Qty. 6)	239-82166-00 (Qty. 6)	239-82166-00 (Qty. 6)
26A	Cleanout Cover Screw (ASME)	---	239-32970-00 (Qty. 6)	239-32970-00 (Qty. 6)	239-32970-00 (Qty. 6)
27	Cleanout Access Cover	243-20299-00	243-20299-00	243-20299-00	243-20299-00
28	Pipe Plug (3/4 NPT)	239-11638-00 ¹	239-11638-00 ¹	239-11638-00 ¹	239-11638-00 ¹
68	Kit-Cleanout (Not For Use With ASME Tanks)	415-54256-00	415-54256-00	415-54256-00	415-54256-00

* Applies to all warranties

** Ordering a complete burner rack may increase delivery time. Please order the specific component required for the quickest delivery.

*** No LP version model available.

**** No Low Nox versions available over 400K btuh.

Anode may need to be cut to length. See page 32.

▲ Applies when "E" is present in model number (Example: D38T155E3N).

¹ For serial numbers PRIOR to GB13067706.

² For serial numbers AFTER and including GB13067706.

³ For serial numbers PRIOR to HA14465923.

⁴ For serial numbers including and AFTER HA14465923

Item	Description	Model	Model	Model	Model
		D100L199(E)*(N,X)	D100L250(E)*(N,X)(A)	D100L270(E)*N(A)	D100L300(E)*(N,X)(A)
29	Burner Rack Complete (Natural Gas) **	243-81743-01	243-81743-03	243-81743-05	243-81743-07
	Burner Rack Complete (Nat. Gas)(Lo NOX) **▲	243-42536-01	243-42536-02	243-42536-03	243-42536-04
	Burner Rack Complete (LP Gas) **	243-81743-02	243-81743-06	---	243-81743-08
30	Burner Rack Only	239-81969-02	239-81969-02	239-81969-02	239-81969-02
31	Gas Valve (Natural Gas)	415-80830-02	415-80830-02	415-80830-02	415-80830-02
	Gas Valve (LP Gas)	415-80831-02	415-80831-02	415-80831-02	415-80831-02
32	Burner Tube (Standard)	228-39177-00 (Qty. 7)	228-39177-00 (Qty. 7)	228-39177-00 (Qty. 7)	228-39177-00 (Qty. 7)
	Burner Tube (Lo-NOX) ▲	228-42490-00 (Qty. 7)	228-42490-00 (Qty. 7)	228-42490-00 (Qty. 7)	228-42490-00 (Qty. 7)
33	Burner Manifold (Natural Gas)	233-81725-00	233-81725-00	233-81725-00	233-81725-00
	Burner Manifold (LP Gas)	233-81725-00	233-81725-00	233-81725-00	233-81725-00
33A	Burner Manifold (Natural Gas)	---	---	---	---
	Burner Manifold (LP Gas)	---	---	---	---
33B	Burner Manifold (Natural Gas)	---	---	---	---
34	Main Burner Orifice (Natural Gas) (0ft to 2000ft)	234-06016-42 (Qty. 7)	234-06016-37 (Qty. 7)	234-06016-36 (Qty. 7)	234-06016-33 (Qty. 7)
	High Altitude (Natural Gas) (2001ft to 5000ft)	234-06016-43 (Qty. 7)	234-06016-40 (Qty. 7)	234-06016-38 (Qty. 7)	234-06016-36 (Qty. 7)
	High Altitude (Natural Gas) (5001ft to 8000ft)	234-06016-45 (Qty. 7)	234-06016-42 (Qty. 7)	234-06016-73 (Qty. 7)	234-06016-37 (Qty. 7)
	High Altitude (Natural Gas) (8001ft & above)	234-06016-45 (Qty. 7)	234-06016-42 (Qty. 7)	234-06016-73 (Qty. 7)	234-06016-38 (Qty. 7)
	Main Burner Orifice (LP Gas) (0ft to 2000ft)	234-06016-1/16 (Qty. 7)	234-06016-50 (Qty. 7)	***	234-06016-48 (Qty. 7)
	High Altitude (LP Gas) (2001ft to 5000ft)	234-06016-53 (Qty. 7)	234-06016-52 (Qty. 7)	***	234-06016-50 (Qty. 7)
	High Altitude (LP Gas) (5001ft to 8000ft)	234-06016-54 (Qty. 7)	234-06016-1/16 (Qty. 7)	***	234-06016-51 (Qty. 7)
	High Altitude (LP Gas) (8001ft & above)	234-06016-54 (Qty. 7)	234-06016-53 (Qty. 7)	***	234-06016-51 (Qty. 7)
35	Pilot Shield	239-41333-00	239-41333-00	239-41333-00	239-41333-00
36	Pilot Assembly (Natural Gas)	415-41323-01	415-41323-01	415-41323-01	415-41323-01
	Pilot Assembly (LP Gas)	233-41323-02	233-41323-02	***	233-41323-02
37	Pilot Orifice (Natural Gas)	233-41606-01	233-41606-01	233-41606-01	233-41606-01
	Pilot Orifice (LP Gas)	233-41606-02	233-41606-02	***	233-41606-02
38	Aluminum Pilot Tube	233-80361-01	233-80361-01	233-80361-01	233-80361-01
39	Burner Support	239-45181-00	239-45181-00	239-45181-00	239-45181-00
40	Draft Panel	239-39420-00	239-39420-00	239-39420-00	239-39420-00
41	Pilot Mounting Screw	239-11706-00 (Qty. 2)	239-11706-00 (Qty. 2)	239-11706-00 (Qty. 2)	239-11706-00 (Qty. 2)
42	Sreet Elbow 1" NPT (Natural)	---	---	---	---
43	Pipe Nipple 1" NPT (Natural)	---	---	---	---
44	Elbow 1" NPT (Natural)	---	---	---	---
45	Gas Support Bracket (Natural)	---	---	---	---
	Gas Support Bracket (LP)	---	---	---	---
46	Ground Wire	239-38951-52	239-38951-52	239-38951-52	239-38951-52
-	LP to Natural Gas Conversion Kit	265-46033-08	265-46033-07	---	265-46033-09

* Applies to all warranties

** Ordering a complete burner rack may increase delivery time. Please order the specific component required for the quickest delivery.

*** No LP version model available.

**** No Low Nox versions available over 400K btuh.

Anode may need to be cut to length. See page 32.

▲ Applies when "E" is present in model number (Example: D38T155E3N).

¹ For serial numbers PRIOR to GB13067706.

² For serial numbers AFTER and including GB13067706.

³ For serial numbers PRIOR to HA14465923.

⁴ For serial numbers including and AFTER HA14465923

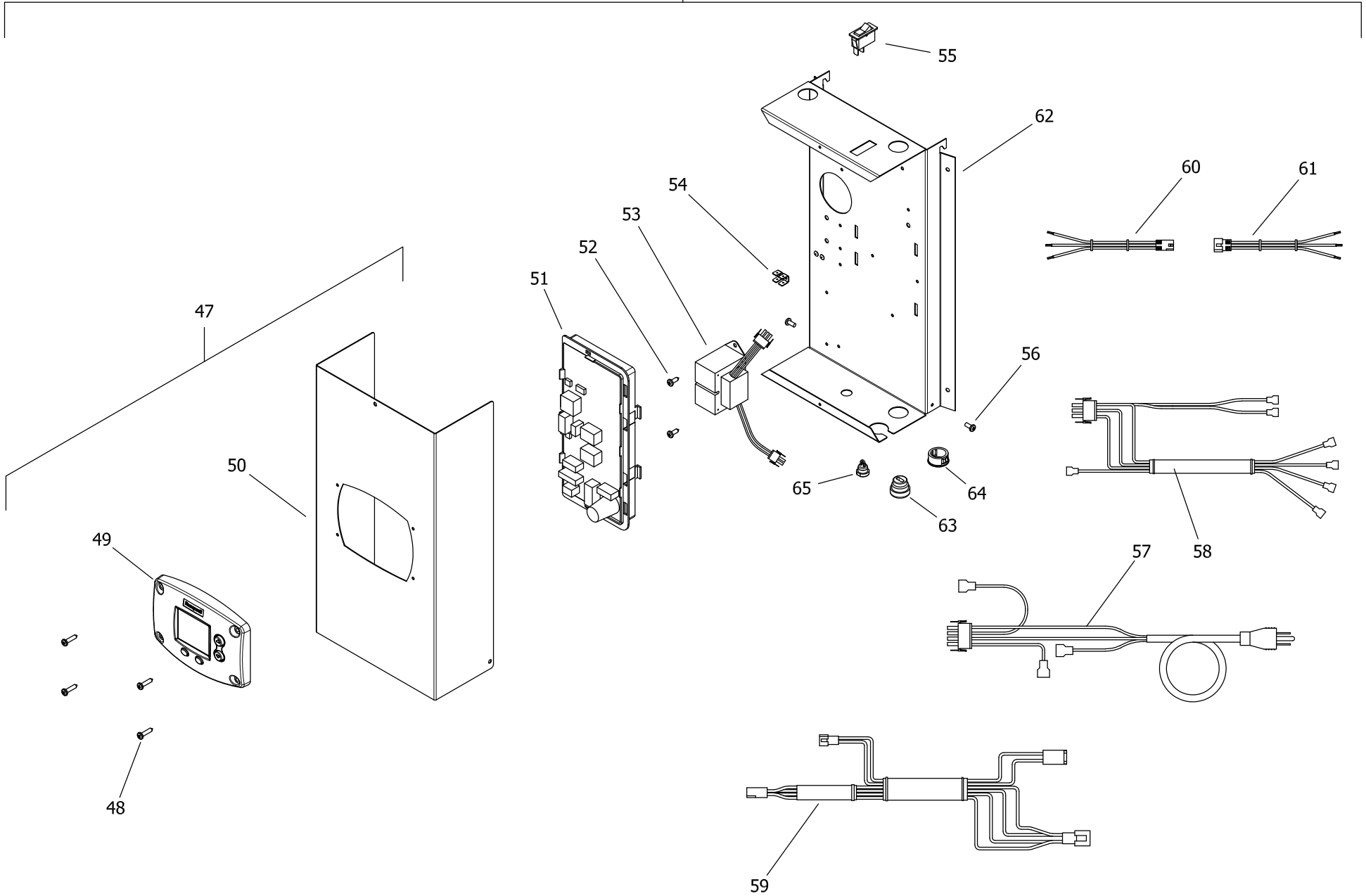

Item	Description	Model	Model	Model	Model
		D100L199(E)*(N,X)	D100L250(E)*(N,X)(A)	D100L270(E)*N(A)	D100L300(E)*(N,X)(A)
21	Control Box Assembly (Dual Sensor)	243-46560-03 ²	243-46560-03 ²	243-46560-03 ²	243-46560-03 ²
	Control Box Assembly (Single Sensor)	243-46614-02 ¹	243-46614-02 ¹	243-46614-02 ¹	243-46614-02 ¹
47	Control Box Cover Assembly	243-46615-01	243-46615-01	243-46615-01	243-46615-01
48	Screw #8-18 X 3/4 Pan Head CR	239-43863-00	239-43863-00	239-43863-00	239-43863-00
49	Resideo Temperature Control Display	233-46557-00	233-46557-00	233-46557-00	233-46557-00
50	Control Box Cover	239-46509-00	239-46509-00	239-46509-00	239-46509-00
51	Integrated Control Board (Dual Sensor)	233-46616-00 ²	233-46616-00 ²	233-46616-00 ²	233-46616-00 ²
	Integrated Control Board (Single Sensor)	233-47260-00 ¹	233-47260-00 ¹	233-47260-00 ¹	233-47260-00 ¹
52	Screw #8-18 X 1/2 Pan Head CR	239-43736-00	239-43736-00	239-43736-00	239-43736-00
53	Transformer 110V	415-44072-01	415-44072-01	415-44072-01	415-44072-01
54	Ground Lug 1/4 x .032	239-80112-00	239-80112-00	239-80112-00	239-80112-00
55	Power On/Off Switch	239-49391-00	239-49391-00	239-49391-00	239-49391-00
56	Screw 8/32 X 1/4 Pan Head CR w/adh.	239-46522-00	239-46522-00	239-46522-00	239-46522-00
57	Primary Transformer Wiring Harness	239-46531-00	239-46531-00	239-46531-00	239-46531-00
58	Secondary Transformer Wiring Harness	239-46530-00	239-46530-00	239-46530-00	239-46530-00
59	Power Cord Wiring Harness	239-46533-00	239-46533-00	239-46533-00	239-46533-00
60	Gas Valve Control Wiring Harness	239-46529-01	239-46529-01	239-46529-01	239-46529-01
61	Damper Wiring Harness (Dual Sensor)	239-46526-02 ²	239-46526-02 ²	239-46526-02 ²	239-46526-02 ²
	Damper Wiring Harness (Single Sensor)	239-46527-03 ¹	239-46527-03 ¹	239-46527-03 ¹	239-46527-03 ¹
62	Display Control Wiring Harness	239-46944-00	239-46944-00	239-46944-00	239-46944-00
63	Display Cover Wiring Harness	239-46617-00	239-46617-00	239-46617-00	239-46617-00
64	Control Box Panel	239-46508-00	239-46508-00	239-46508-00	239-46508-00
65	Strain Relief Bushing 7/8"	239-80372-00	239-80372-00	239-80372-00	239-80372-00
66	Snap-in Bushing 7/8"	239-80406-00	239-80406-00	239-80406-00	239-80406-00
67	Strain Relief Bushing 1/2"	239-44575-00	239-44575-00	239-44575-00	239-44575-00

* Applies to all warranties

** Ordering a complete burner rack may increase delivery time. Please order the specific component required for the quickest delivery.

*** No LP version model available.

**** No Low Nox versions available over 400K btuh.

Anode may need to be cut to length. See page 32.

▲ Applies when "E" is present in model number (Example: D38T155E3N).

¹ For serial numbers PRIOR to GB13067706.

² For serial numbers AFTER and including GB13067706.

³ For serial numbers PRIOR to HA14465923.

⁴ For serial numbers including and AFTER HA14465923

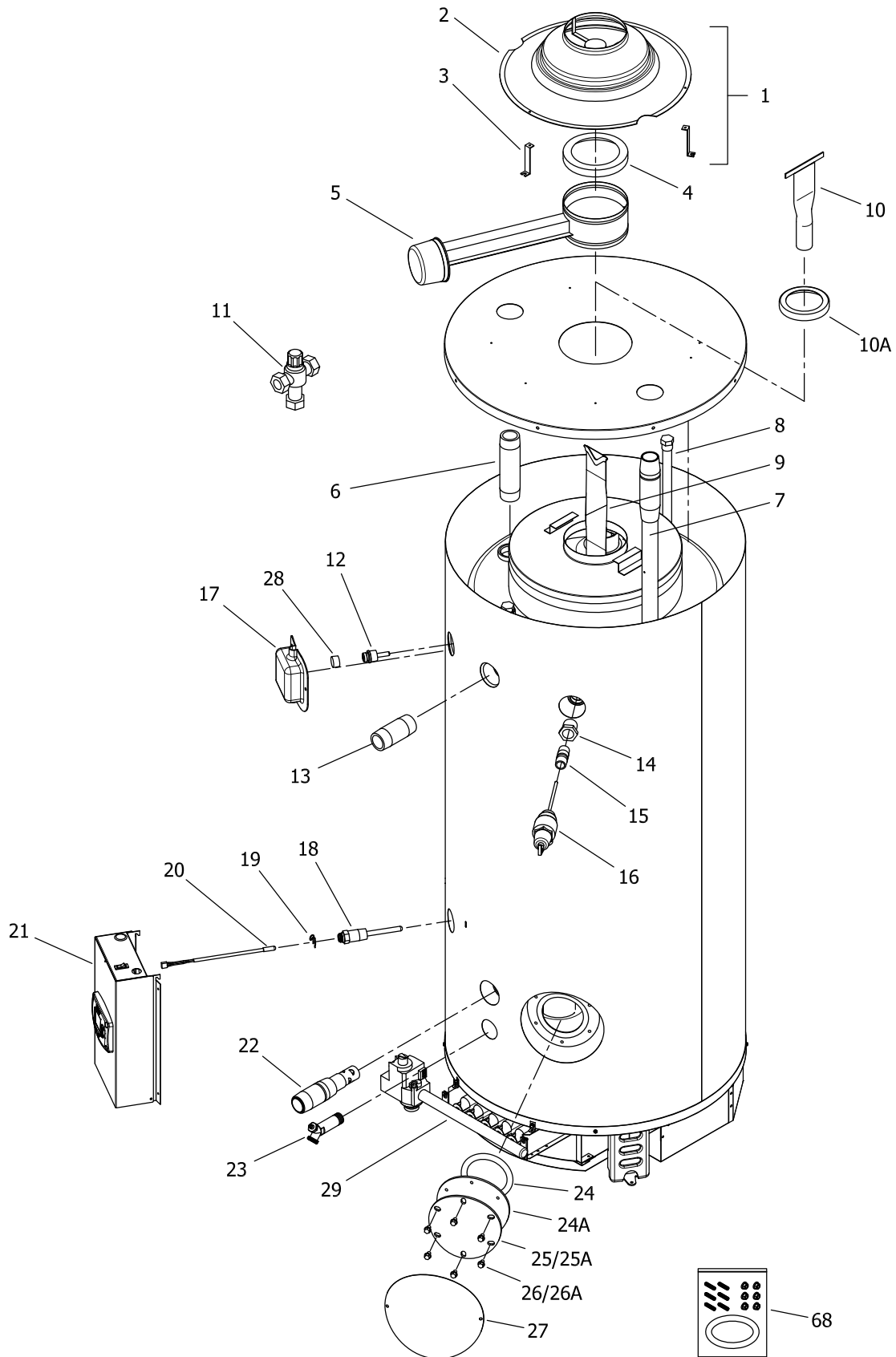

Item	Description	Model	Model	Model	Model
		D100S199(E)*(N,X)	D100S250(E)*(N,X)(A)	D100T199(E)*(N,X)	D100T250(E)*(N,X)(A)
1	Draft Diverter Complete with Leg Kit	265-46548-00	265-46548-00	265-46544-00	265-46544-00
2	Draft Diverter Only	239-81733-00-01	239-81733-00-01	239-81986-00-01	239-81986-00-01
3	Draft Diverter Leg Kit Only	243-43690-09	243-43690-09	243-43690-02	243-43690-02
4	Flue Damper Reducer	239-81811-00	239-81811-00	---	---
5	Flue Damper Complete	265-43113-00	265-43113-00	415-42973-00	415-42973-00
6	Hot Water Outlet Nipple (Top)	229-40913-01	229-40913-01	229-40913-01	229-40913-01
7	Cold Water Inlet Diptube (Top)	415-46709-01	415-46709-01	415-46709-02	415-46709-02
8	Plug Type Anode Rod (Magnesium)#	224-47782-07 (Qty. 4)	224-47782-07 (Qty. 4)	224-47782-12 (Qty. 2)	224-47782-12 (Qty. 2)
	Plug Type Anode Rod (Aluminum)#	224-38508-06 (Qty. 4)	224-38508-06 (Qty. 4)	224-38508-08 (Qty. 2)	224-38508-08 (Qty. 2)
	Plug Type Anode Rod (A420 Aluminum)#	224-49559-04 (Qty. 4)	224-49559-04 (Qty. 4)	224-49559-04 (Qty. 2)	224-49559-04 (Qty. 2)
9	Flue Baffle	243-81735-00 (Qty. 9)	243-81566-00 (Qty. 9)	243-39392-00 (Qty. 8)	243-39341-00 (Qty. 8)
10	Flue Core	---	---	---	---
10A	Flue Reducer	---	---	---	---
11	ASSE Approved Mixing Valve (Optional)	239-51778-00	239-51778-00	239-51778-00	239-51778-00
12	Upper Thermostat Sensor	415-82033-00 ⁴	415-82033-00 ⁴	415-82033-00	415-82033-00
13	Hot Water Outlet Nipple (Side)	229-40913-02	229-40913-02	229-40913-02	229-40913-02
14	1" NPT to 3/4" NPT Reducer Bushing	239-02052-00	---	239-02052-00	---
15	3/4" NPT Nipple	239-81075-00	---	229-32762-04	---
	1" NPT Nipple	---	239-80982-00	---	229-32762-19
16	T&P Valve	415-30246-00	415-33630-04	415-30246-00	415-33630-04
17	Utility Cover	239-80281-03 ⁴	239-80281-03 ⁴	239-80281-03	239-80281-03
18	Lower Thermostat Well	233-46558-01	233-46558-01	233-46558-02	233-46558-02
19	Clip for Lower Thermostat	233-45242-00	233-45242-00	233-45242-00	233-45242-00
20	Lower Thermostat Sensor	415-46553-01	415-46553-01	415-46553-01	415-46553-01
21	Control Box Assembly	243-46614-03	243-46614-03	243-46560-05	243-46560-05
22	Cold Water Inlet Diptube (Side)	415-44731-00	415-44731-00	415-44731-00	415-44731-00
23	Brass Drain Valve	415-42351-02	415-42351-02	415-42351-04	415-42351-04
24	Cleanout O-Ring Gasket	205-18427-00	205-18427-00	205-18427-00	205-18427-00
24A	Cleanout Gasket (ASME)	---	205-32942-00	---	205-32942-00
25	Cleanout Cover	205-18428-00	205-18428-00	205-18428-00	205-18428-00
25A	Cleanout Cover (ASME)	---	205-32941-00	---	205-32941-00
26	Cleanout Cover Screw	239-82166-00 (Qty. 6)	239-82166-00 (Qty. 6)	239-82166-00 (Qty. 6)	239-82166-00 (Qty. 6)
26A	Cleanout Cover Screw (ASME)	---	239-32970-00 (Qty. 6)	---	239-32970-00 (Qty. 6)
27	Cleanout Access Cover	243-20299-00	243-20299-00	243-20299-00	243-20299-00
28	Pipe Plug (3/4 NPT)	239-11638-00	239-11638-00	---	---
68	Kit-Cleanout (Not For Use With ASME Tanks)	415-54256-00	415-54256-00	415-54256-00	415-54256-00

* Applies to all warranties

** Ordering a complete burner rack may increase delivery time. Please order the specific component required for the quickest delivery.

*** No LP version model available.

**** No Low Nox versions available over 400K btuh.

Anode may need to be cut to length. See page 32.

▲ Applies when "E" is present in model number (Example: D38T155E3N).

¹ For serial numbers PRIOR to GB13067706.

² For serial numbers AFTER and including GB13067706.

³ For serial numbers PRIOR to HA14465923.

⁴ For serial numbers including and AFTER HA14465923

Item	Description	Model	Model	Model	Model
		D100S199(E)*(N,X)	D100S250(E)*(N,X)(A)	D100T199(E)*(N,X)	D100T250(E)*(N,X)(A)
29	Burner Rack Complete (Natural Gas) **	243-39205-05	243-39205-09	243-39205-05	243-39205-09
	Burner Rack Complete (Nat. Gas)(Lo NOX) **▲	243-42563-02	243-42563-04	243-42563-02	243-42563-04
	Burner Rack Complete (LP Gas) **	243-39205-06	243-39205-10	243-39205-06	243-39205-10
30	Burner Rack Only	233-81969-01	233-81969-01	233-81969-01	233-81969-01
31	Gas Valve (Natural Gas)	415-80830-02	415-80830-02	415-80830-02	415-80830-02
	Gas Valve (LP Gas)	415-80831-02	415-80831-02	415-80831-02	415-80831-02
32	Burner Tube (Standard)	228-39177-00 (Qty. 5)	228-39177-00 (Qty. 5)	228-39177-00 (Qty. 5)	228-39177-00 (Qty. 5)
	Burner Tube (Lo-NOX) ▲	228-42490-00 (Qty. 5)	228-42490-00 (Qty. 5)	228-42490-00 (Qty. 5)	228-42490-00 (Qty. 5)
33	Burner Manifold (Natural Gas)	233-39170-00	233-39170-00	233-39170-00	233-39170-00
	Burner Manifold (LP Gas)	233-39170-00	233-39170-00	233-39170-00	233-39170-00
33A	Burner Manifold (Natural Gas)	---	---	---	---
	Burner Manifold (LP Gas)	---	---	---	---
33B	Burner Manifold (Natural Gas)	---	---	---	---
34	Main Burner Orifice (Natural Gas) (0ft to 2000ft)	234-06016-35 (Qty. 5)	234-06016-31 (Qty. 5)	234-06016-35 (Qty. 5)	234-06016-31 (Qty. 5)
	High Altitude (Natural Gas) (2001ft to 5000ft)	234-06016-37 (Qty. 5)	234-06016-32 (Qty. 5)	234-06016-37 (Qty. 5)	234-06016-32 (Qty. 5)
	High Altitude (Natural Gas) (5001ft to 8000ft)	234-06016-39 (Qty. 5)	234-06016-34 (Qty. 5)	234-06016-39 (Qty. 5)	234-06016-34 (Qty. 5)
	High Altitude (Natural Gas) (8001ft & above)	234-06016-40 (Qty. 5)	234-06016-35 (Qty. 5)	234-06016-40 (Qty. 5)	234-06016-35 (Qty. 5)
	Main Burner Orifice (LP Gas) (0ft to 2000ft)	234-06016-49 (Qty. 5)	234-06016-46 (Qty. 5)	234-06016-49 (Qty. 5)	234-06016-46 (Qty. 5)
	High Altitude (LP Gas) (2001ft to 5000ft)	234-06016-50 (Qty. 5)	234-06016-48 (Qty. 5)	234-06016-50 (Qty. 5)	234-06016-48 (Qty. 5)
	High Altitude (LP Gas) (5001ft to 8000ft)	234-06016-51 (Qty. 5)	234-06016-49 (Qty. 5)	234-06016-51 (Qty. 5)	234-06016-49 (Qty. 5)
	High Altitude (LP Gas) (8001ft & above)	234-06016-52 (Qty. 5)	234-06016-50 (Qty. 5)	234-06016-52 (Qty. 5)	234-06016-50 (Qty. 5)
35	Pilot Shield	239-41333-00	239-41333-00	239-41333-00	239-41333-00
36	Pilot Assembly (Natural Gas)	415-41323-01	415-41323-01	415-41323-01	415-41323-01
	Pilot Assembly (LP Gas)	233-41323-02	233-41323-02	233-41323-02	233-41323-02
37	Pilot Orifice (Natural Gas)	233-41606-01	233-41606-01	233-41606-01	233-41606-01
	Pilot Orifice (LP Gas)	233-41606-02	233-41606-02	233-41606-02	233-41606-02
38	Aluminum Pilot Tube	233-80361-01	233-80361-01	233-80361-01	233-80361-01
39	Burner Support	239-45180-00	239-45180-00	239-45180-00	239-45180-00
40	Draft Panel	239-39419-00	239-39419-00	239-39419-00	239-39419-00
41	Pilot Mounting Screw	239-11706-00 (Qty. 2)	239-11706-00 (Qty. 2)	239-11706-00 (Qty. 2)	239-11706-00 (Qty. 2)
42	Sreet Elbow 1" NPT (Natural)	---	---	---	---
43	Pipe Nipple 1" NPT (Natural)	---	---	---	---
44	Elbow 1" NPT (Natural)	---	---	---	---
45	Gas Support Bracket (Natural)	---	---	---	---
	Gas Support Bracket (LP)	---	---	---	---
46	Ground Wire	239-38951-52	239-38951-52	239-38951-52	239-38951-52
-	LP to Natural Gas Conversion Kit	265-46033-06	265-46033-10	265-46033-06	265-46033-10

* Applies to all warranties

** Ordering a complete burner rack may increase delivery time. Please order the specific component required for the quickest delivery.

*** No LP version model available.

**** No Low Nox versions available over 400K btuh.

Anode may need to be cut to length. See page 32.

▲ Applies when "E" is present in model number (Example: D38T155E3N).

¹ For serial numbers PRIOR to GB13067706.

² For serial numbers AFTER and including GB13067706.

³ For serial numbers PRIOR to HA14465923.

⁴ For serial numbers including and AFTER HA14465923

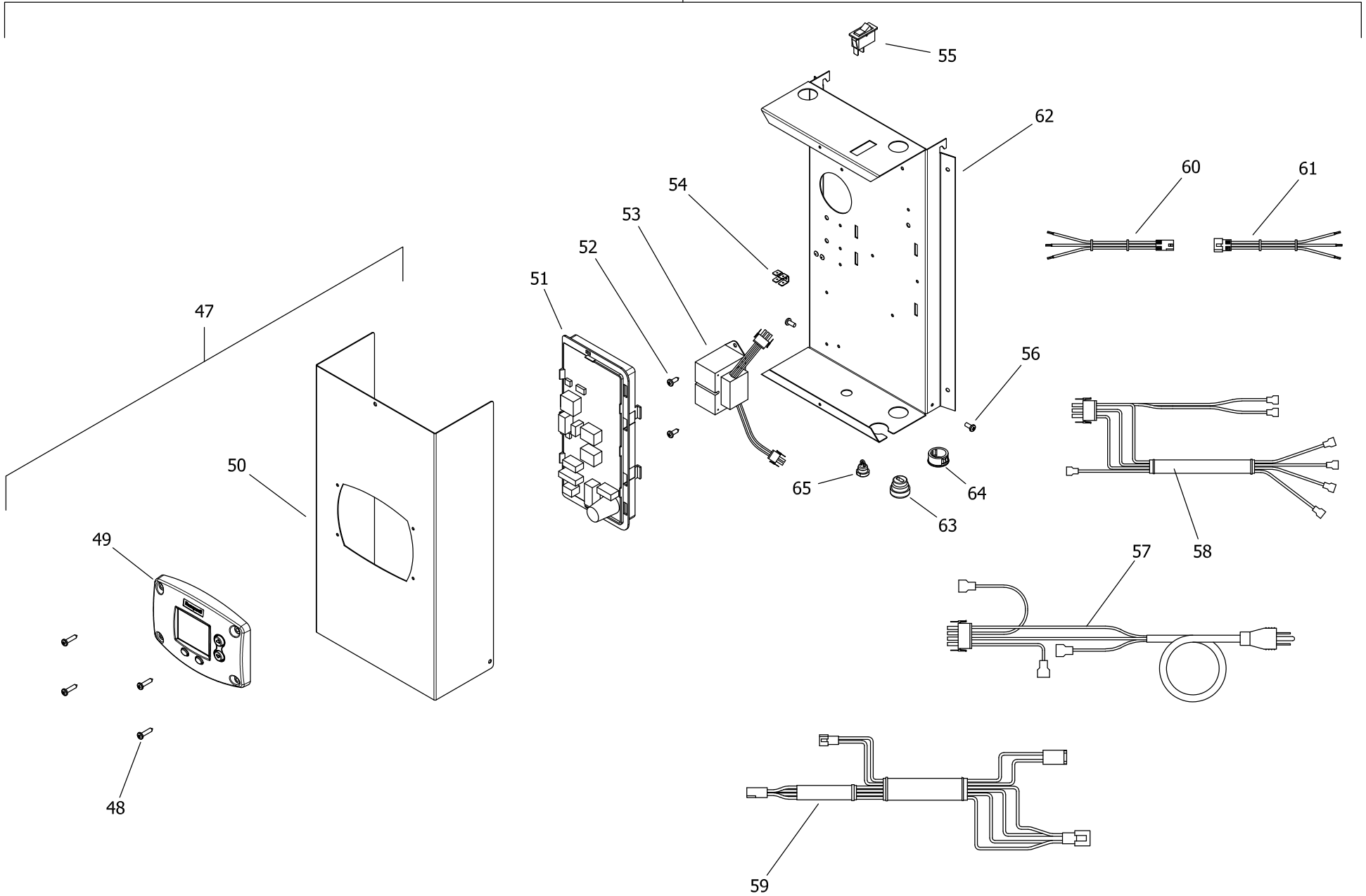

Item	Description	Model	Model	Model	Model
		D100S199(E)*(N,X)	D100S250(E)*(N,X)(A)	D100T199(E)*(N,X)	D100T250(E)*(N,X)(A)
21	Control Box Assembly (Dual Sensor)	243-46560-03 ¹	243-46560-03 ¹	243-46560-05	243-46560-05
	Control Box Assembly (Single Sensor)	243-46614-03 ³	243-46614-03 ³	---	---
47	Control Box Cover Assembly	243-46615-01	243-46615-01	243-46615-01	243-46615-01
48	Screw #8-18 X 3/4 Pan Head CR	239-43863-00	239-43863-00	239-43863-00	239-43863-00
49	Resideo Temperature Control Display	233-46557-00	233-46557-00	233-46557-00	233-46557-00
50	Control Box Cover	239-46509-00	239-46509-00	239-46509-00	239-46509-00
51	Integrated Control Board (Dual Sensor)	233-46616-00 ⁴	233-46616-00 ⁴	233-46616-00	233-46616-00
	Integrated Control Board (Single Sensor)	233-47260-00 ³	233-47260-00 ³	---	---
52	Screw #8-18 X 1/2 Pan Head CR	239-43736-00	239-43736-00	239-43736-00	239-43736-00
53	Transformer 110V	415-44072-01	415-44072-01	415-44072-01	415-44072-01
54	Ground Lug 1/4 x .032	239-80112-00	239-80112-00	239-80112-00	239-80112-00
55	Power On/Off Switch	239-49391-00	239-49391-00	239-49391-00	239-49391-00
56	Screw 8/32 X 1/4 Pan Head CR w/adh.	239-46522-00	239-46522-00	239-46522-00	239-46522-00
57	Primary Transformer Wiring Harness	239-46531-00	239-46531-00	239-46531-00	239-46531-00
58	Secondary Transformer Wiring Harness	239-46530-00	239-46530-00	239-46530-00	239-46530-00
59	Power Cord Wiring Harness	239-46533-00	239-46533-00	239-46533-00	239-46533-00
60	Gas Valve Control Wiring Harness	239-46529-02	239-46529-02	239-46529-01	239-46529-01
61	Damper Wiring Harness (Dual Sensor)	239-46526-02 ⁴	239-46526-02 ⁴	239-46526-03	239-46526-03
	Damper Wiring Harness (Single Sensor)	239-46527-03 ³	239-46527-03 ³	---	---
62	Display Control Wiring Harness	239-46944-00	239-46944-00	239-46944-00	239-46944-00
63	Display Cover Wiring Harness	239-46617-00	239-46617-00	239-46617-00	239-46617-00
64	Control Box Panel	239-46508-00	239-46508-00	239-46508-00	239-46508-00
65	Strain Relief Bushing 7/8"	239-80372-00	239-80372-00	239-80372-00	239-80372-00
66	Snap-in Bushing 7/8"	239-80406-00	239-80406-00	239-80406-00	239-80406-00
67	Strain Relief Bushing 1/2"	239-44575-00	239-44575-00	239-44575-00	239-44575-00

* Applies to all warranties

** Ordering a complete burner rack may increase delivery time. Please order the specific component required for the quickest delivery.

*** No LP version model available.

**** No Low Nox versions available over 400K btuh.

Anode may need to be cut to length. See page 32.

▲ Applies when "E" is present in model number (Example: D38T155E3N).

¹ For serial numbers PRIOR to GB13067706.

² For serial numbers AFTER and including GB13067706.

³ For serial numbers PRIOR to HA14465923.

⁴ For serial numbers including and AFTER HA14465923

Reference Chart of Anode Length by Model

Model	Hex Head Anode Cut Length (End to end)	
	Inches	Millimeters
D38T155(E)*(N,X)	17.5	445
D65T370(E)*(N,X)(A)	43.5	1105
D65T399(E)*N(A)	43.5	1105
D75T125(E)*(N,X)	40	1016
D75T160(E)*(N,X)	40	1016
D75T300*(N,X)(A)	40	1016
D80L399(E)*(N,X)(A)	35	889
D80L450*(N,X)(A)	35	889
D80L505*(N,X)(A)	35	889
D80T180(E)*(N,X)	43.5	1105
D80T199(E)*(N,X)	43.5	1105
D80T250(E)*(N,X)(A)	43.5	1105
D80T425*(N,X)(A)	52	1321
D80T505*(N,X)(A)	52	1321
D100L199(E)*(N,X)	40	1016
D100L250(E)*(N,X)(A)	40	1016
D100L270(E)*N(A)	40	1016
D100L300(E)*(N,X)(A)	40	1016
D100S199(E)*(N,X)	43.5	1105
D100S250(E)*(N,X)(A)	43.5	1105
D100T199(E)*(N,X)	52	1321
D100T250(E)*(N,X)(A)	52	1321



United States

Sales 800-523-2931

Technical Support 800-334-3393

Email techserv@bradfordwhite.com

Warranty 800-531-2111

Email warranty@bradfordwhite.com

Service Parts 800-538-2020

Email parts@bradfordwhite.com

Canada

Sales & Technical Support 866-690-0961 905-203-0600

Fax 905-636-0666

Warranty bwccwarranty@bradfordwhite.com

Technical Support bwccotech@bradfordwhite.com

Service Parts orders@bradfordwhitecanada.com

Orders ca.orders@bradfordwhite.com

For U.S. and Canada field service,
contact your professional installer or
local Bradford White sales representative.

International

General Contact international@bradfordwhite.com