

BIRO[®]

Model 33

Power Meat Cutter

Operating and Service Parts Identification Manual

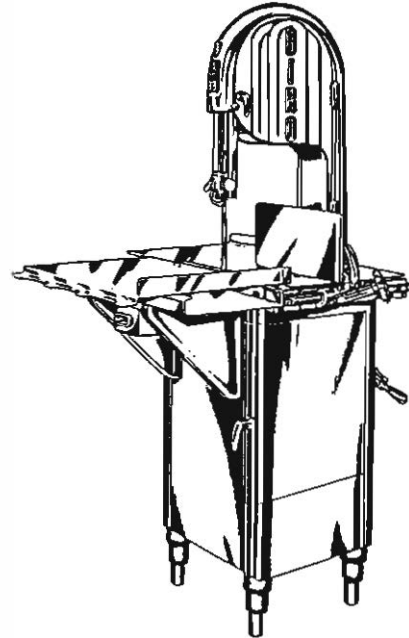

Applicable on Md 33 Serial No. 33
19690 Except as Noted

The BIRO Model 33 Power Meat Cutter was manufactured from December 26, 1945 to June 17, 1969 when it was replaced by the BIRO Model 3334 Power Meat Cutter.

This manual is published and supplied as an aid to purchase replacement parts for those machines still in service.

Please check your machine to see that warning labels (Item No. 653, Pages 5 & 6) are attached to your machines. If there are no warning labels, please advise The BIRO Manufacturing Company, phone (419) 798-4451 and the warning labels will be sent at "no charge". Please review the WARNING (Page 2, 1 through 15).

When ordering replacement parts, the machine pictured may not exactly match your machine. The serial number is located on model plate riveted to the head and is stamped on the top of the base structure. Please give the serial number of your machine when ordering parts.

If the model plate is lost, please give the following information which will help identify the vintage of your unit.

1. The base feet — are they square or round? If round, the diameter of pipe leg.
2. Does the right base door have a split door (pictured on Page 5) or is it one piece (full length)?
3. What is the distance between the platter rods (Item #15212W — Page 6)?
4. What is the length of the channel (Item No. S120S, Page 5) the meat carriage travels in?
5. Does the meat carriage (Item No. A33155, Page 6) have four or six bearings?

Please contact The BIRO Manufacturing Company for a BIRO Authorized Service Agency nearest you.

THE BIRO MANUFACTURING COMPANY

MARBLEHEAD, OHIO 43440-2099

Power Cutters Since 1921

PHONE (419) 798-4451 • FAX (419) 798-9106

OPERATING AND SERVICE MANUAL FOR BIRO MODEL 33

WARNING TO ALL PURCHASERS, OPERATORS AND OPERATION SUPERVISORS:

FAILURE TO READ AND ADHERE TO THE FOLLOWING IMPORTANT INSTRUCTIONS COULD RESULT IN BODILY INJURY.

- (1) Do not electric wire this power cutter. Have only a qualified and certified electrician wire this power cutter as required. Be sure machine is grounded. Failure to ground this machine could result in electric shock.
- (2) Do not place machine on sloping floor. Always place machine on flat non-skid floor.
- (3) Do not use this power cutter for non-food products.
- (4) Do not use this power cutter to cut pigs feet.
- (5) Do not attempt to operate this power cutter until this machine has been inspected and demonstrated by the seller — recognized BIRO Representative.
- (6) Do not attempt to operate this power cutter unless you or the operator has been properly trained. Improper use or operation of this power cutter could result in bodily injury.
- (7) Do not leave power cutter in operation — unattended.
- (8) Do not tamper, bypass, remove fixed guards, safety interlock electrical switches or any other safety device.
- (9) Do not at any time force feed product through this power cutter.
- (10) Do not alter or modify this power cutter in any way from its original form. This power cutter in its original form meets the intent of O.S.H.A. applicable standards.
- (11) Always use safety pusher plate supplied with each power cutter when cutting small product.
- (12) do not touch moving blade or moving parts. Never place hand or arm between blade and head column structure.
- (13) Always disconnect power supply before removing shrouds, removable guards, covers, doors, fences, panels for servicing, cleaning or any other reason.
- (14) Use only BIRO parts and accessories properly installed, contact your nearest service agency or The BIRO Manufacturing Company for authorized referral assistance.
- (15) Power cutter operating manuals as supplied with this power cutter are available from BIRO.

FAILURE TO COMPLY WITH THIS WARNING NOTICE COULD RESULT IN BODILY INJURY.

**THE BIRO MANUFACTURING COMPANY, 1114 WEST MAIN STREET, MARBLEHEAD, OHIO 43440-2099
U.S.A. — PHONE (419) 798-4451 — TELEX NO. 241-003**

TO ASSEMBLE AND SET UP CUTTER FOR USE:

- (1) After placing cutter in operational area, it is imperative that three of the four adjustable foot studs be tightened, using the fourth leg for adjustment to level the cutter.
- (2) The aluminum head, Item No. 15005 comes detached from the base. Slip the head into the Gib, Item No. 260, (slide gibs) section of the base, See Page 5. Make sure the Gibs, Item No. 260, (slide gibs) are oiled or greased to insure free movement.
- (3) To assemble meat gauge plate, Item No. 275, Page 5, to machine loosen the wing nut on right side of meat gauge bracket, Item No. 272-6-S. Raise the right side of the meat gauge bar, Item 15272, and slip the meat gauge plate over the bar, lower bar back to its original position, tighten wing nut. Keep bar well oiled with food machine oil to insure free movement.
- (4) Place upper saw guide removable unit assembly on saw guide bar, Item No. 116-22, and fasten in place with finger lift fastener knob, Item No. 211A-291Q.
- (5) Placing blade on cutter: Lift up nylon filler, Item No. 177, Page 4. Hang blade on upper wheel and hold blade on wheel with left hand. With the right hand force the back of the blade between the two steel saw cleaners, Item No. 131, located below the nylon filler, Item No. 177. Lower the nylon filler, Item No. 177, and insert back of blade in upper saw guide slit, Item No. 602B. The blade has already dropped over the lower wheel and is ready for tightening. Press down on ratchet handle, Item No. 10-1 to tighten. Turn wheel one turn to insure proper tracking and tighten to proper tension. When the tension gauge, Item No. 16197, located at the bottom of the head becomes tight laterally the blade is at its proper tension, Page 6.
- (6) The stationary platter, Item No. A33163, is placed on top of the base and held in place with two platter rods, Item No. 15212W, located on the rear rim of the cutter.
- (7) The sliding meat carriage table, Item No. A33155, is removed by turning movable stop, Item No. 200, clockwise. After the carriage is in the channel for operation turn movable stop, counterclockwise, Page 4.

SAW GUIDE BAR SPRING SERVICING PROCEDURE

Item #193 Saw Guide Bar Spring, is located in the head structure on all BIRO Power Meat Saws. The spring is not visible as it is located within the babbitt pocket area.

Dependent upon the frequency of adjustments, that portion of the saw guide bar spring in constant contact with the guide bar will eventually wear. As the spring becomes worn, a loss of tension will cause the finger lift assembly to slide down or not hold the adjusted height setting. When this happens, the saw guide bar spring, Item #193 must be replaced.

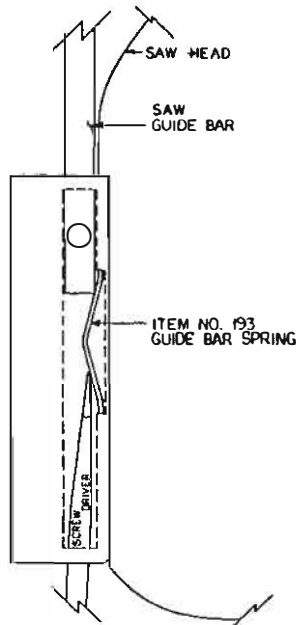

1. Remove the finger lift fastener knob and the finger lift assembly.
2. Remove the finger lift fastener stud.
3. Push the saw guide bar up and out of the top, of the head structure.
4. Remove the saw guide bar spring.
5. Clean and relubricate the babbitt pocket area (the square indented area that seats the saw guide bar spring).
6. Lower the new saw guide bar spring through the top of the babbitt pocket area and guide the spring into position with a standard screwdriver (NOTE: drawing).
7. While holding the saw guide bar spring in position re-enter saw guide bar from the top compressing the saw guide bar spring slightly until the saw guide bar slides past the spring.
8. Replace the finger lift fastener stud, the finger lift assembly and finger lift fastener knob.
9. Test by making several adjustments.

SAW GUIDE BAR AND GUARD SERVICING PROCEDURE

Current Model 3334 SAW GUIDE BAR assemblies and GUARDS fit all BIRO Models 33, 34, and 3334 manufactured.

The factory recommends that when service is performed on any BIRO SAW the servicing agency be sure that the BIRO SAW is equipped with the most current safety features available.

Since 1969 safety requirements have changed. To meet state-of-the-art safety requirements, The Biro Manufacturing Company recommends that before any work is performed on any Model 33 and 34 Power Meat Cutters, the Item No. A116-22 Saw Guide Bar Assembly be installed in the head and Item No. 661-1 Guard be installed on the head door.

Failure to comply with this notice could place an agency performing work on a Model 33 or 34 Power Meat Cutter in a solely liable status. Please follow this recommendation.

MODELS 33, 34 SAW GUIDE BARS AND SAW GUARDS

The BIRO Model 33 was manufactured from December 1945 until June of 1969.

The BIRO Model 34 was manufactured from September 1958 until October 1969.

The Model 33 was originally equipped with a 20" guide bar. The Model 34 was originally equipped with a 18½" guide bar. In 1962 both models were changed to 19" guide bars and in 1967 both models were extended to 21½" until the end of their production.

The SAW GUARD used as original equipment throughout the production of Models 33 and 34 was Item #255.

All Model 33's and 34's in the field should be updated by (Item #A116-22) SAW GUIDE BAR ASSEMBLY complete, (Item #193) SAW GUIDE BAR SPRING, and Item #661-1 DOOR GUARD (see adjacent page). DO NOT DEVIATE FROM THE ITEMS LISTED. These items are matched and engineered to maximize safety for the operator.

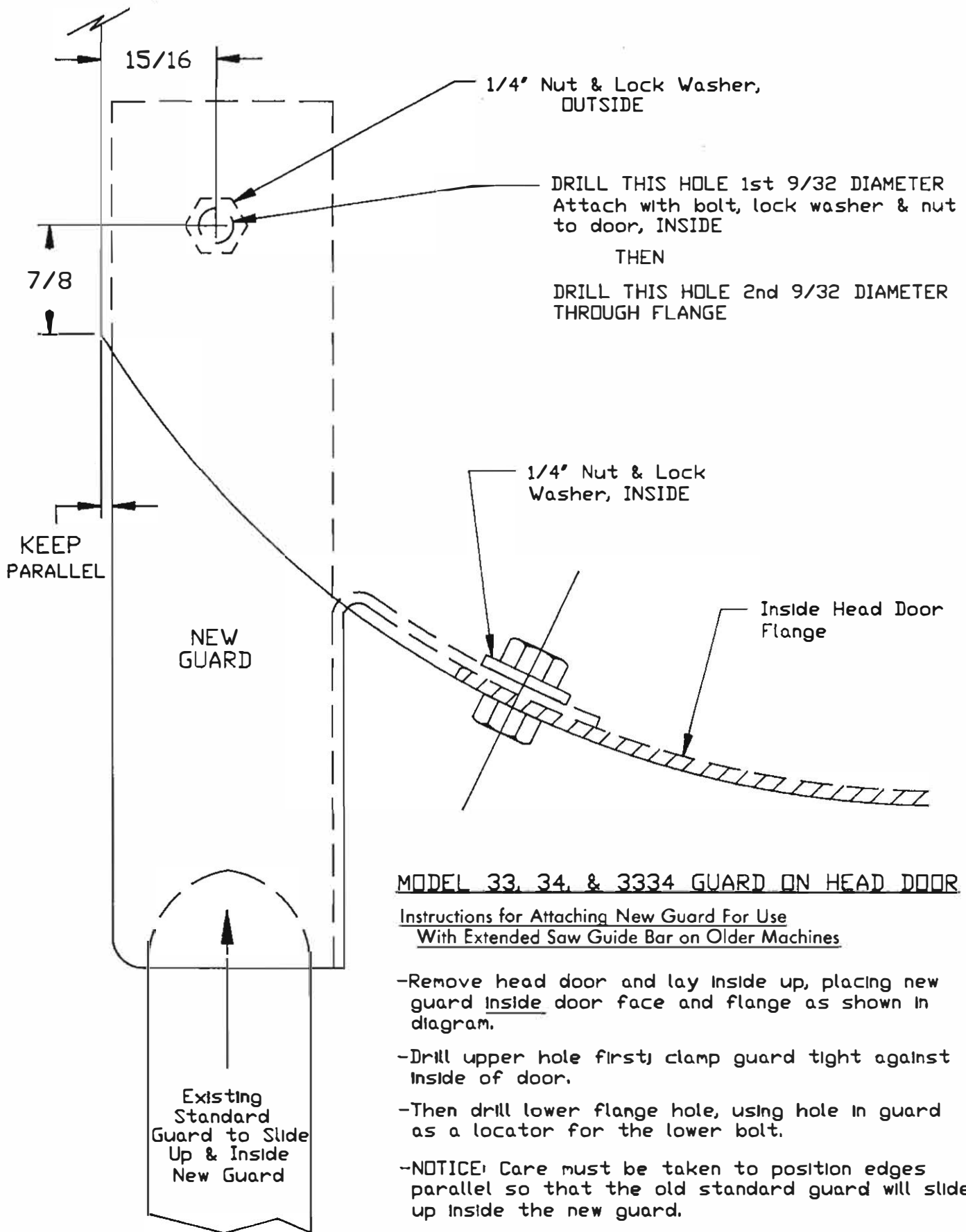

MODEL 33, 34, & 3334 GUARD ON HEAD DOOR

Instructions for Attaching New Guard For Use
With Extended Saw Guide Bar on Older Machines

- Remove head door and lay inside up, placing new guard inside door face and flange as shown in diagram.
- Drill upper hole first; clamp guard tight against inside of door.
- Then drill lower flange hole, using hole in guard as a locator for the lower bolt.
- NOTICE: Care must be taken to position edges parallel so that the old standard guard will slide up inside the new guard.

— NOTE —
**ALWAYS REPORT MACHINE SERIAL
 NO. WHEN ORDERING PARTS**

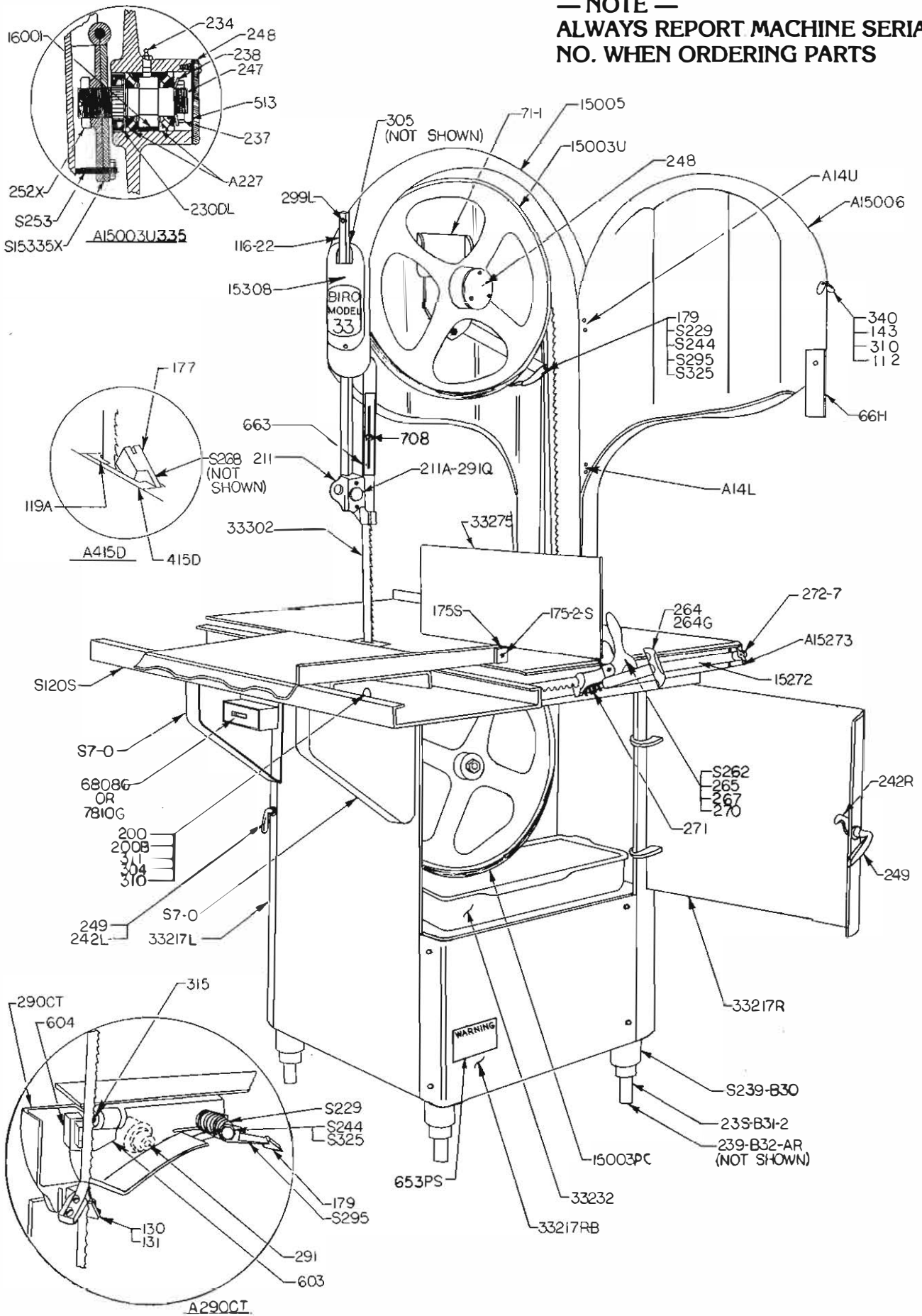

— NOTE —
 ALWAYS REPORT MACHINE SERIAL
 NO. WHEN ORDERING PARTS

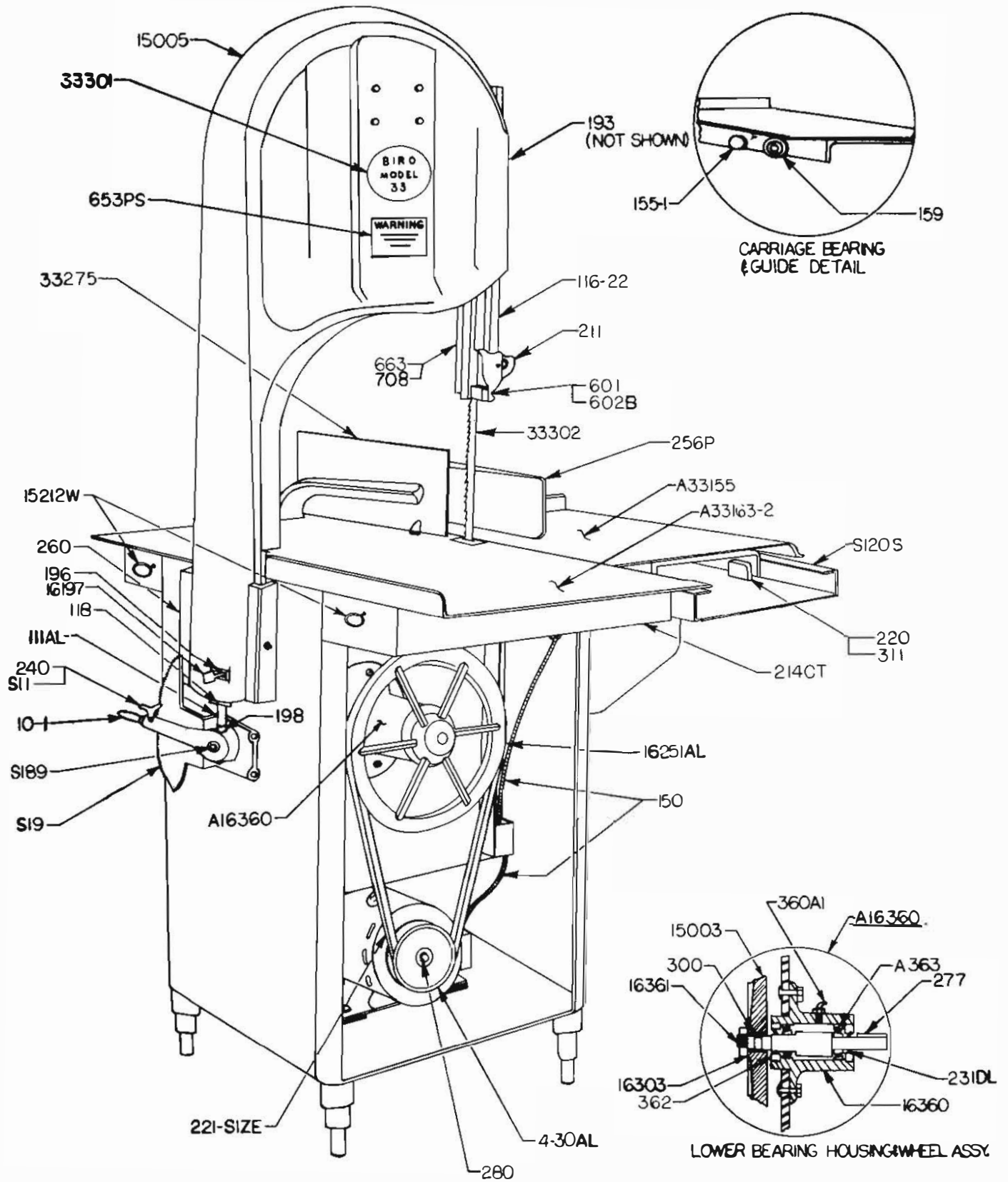

MODEL 33 PART NUMBERS AND DESCRIPTIONS

IMPORTANT

ALWAYS ADVISE SERIAL NUMBER WHEN ORDERING PARTS

S11	Ratchet trigger, SS	231DL	Lower shaft seal
S120S	Channel, 37 inch, #21066 on	234	Upper wheel grease fitting
S189	Ratchet arm stud, SS	236	Motor (SPECIFY CHARACTERISTICS)
S19	Ratchet base, SS	237	Upper shaft castellated lock nut
S229	Wheel cleaner arm spring, SS	238	Upper shaft castellated lock washer
S244	Wheel cleaner arm stud, SS	240	Ratchet trigger spring
S253	Upper wheel aligning screw, SS	242L	Base door lock, left
S262	Meat gauge release handle, SS	242R	Base door lock, right
S268	Sta. bar headless screw, SS	247	Upper shaft
S295	Wheel cleaner arm, SS	248	Upper wheel hub cap
S7-0	Channel bracket, SS	249	Base door handle
111AL	Tension spring pin, w/198 cap	252X	Upper shaft lock nut
112	Head door handle	264	Meat gauge hand wheel
116-22	Saw guide bar, 22"	265	Meat gauge release spring
118	Tension spring plate	267	Meat gauge release cotter spring
119A	Saw guide in sta. bar	270	Meat gauge release spring
130	Saw cleaner bracket, rear	271	Meat gauge worm gear
131	Saw cleaner, SS	277	Lower shaft key
143	Head door catch	280	Motor shaft key
14GP	Head door hinge pin, long	290CT	Cleaning unit casting
15003	Lower wheel, 15"	291	Cleaning unit fastener knob, long
15003U	Upper wheel, 15"	299L	Saw guide bar stop in head, long
15005	Head, #7000 on	300	Lower shaft Woodruff key
15006	Head door, ORDER A15006	304	Carriage stop shoulder screw
15212W	Platter rod, SS	305	Saw guide bar stop in head
15272	Meat gauge gear rack	309	Carriage stop bowed washer
15273	Meat gauge bracket, ORDER A15273	310	Bowed washer
15308	Babbitt pocket shield	311	Rubber bumper for carriage stops
15335X	Upper wheel hinge plate, #6151 on	315	Lower guide bracket stud
159	Meat carriage bearing	33155	Meat carriage, #11530 on, (4 bearing)
16001	Upper main bearing spacer	33155-OS	Meat carriage, to #11529, (6 bearing)
16197	Tension spring gauge	33217L	Left base door, #19690 on
16251AL	Upper V-belt pulley, 11.4 x 1	33217R	Right base door, #19690 on
16303	Lower shaft nut, #6263 on	33217R-B	Right bottom base panel, #19690 on
16360	Lower bearing housing, #6263 on	33232	Scrap bucket, plastic
16361	Lower shaft, #6263 on	33301	Model & s/n plate, (serial no. required)
175S	Thumb guard, nylon	33302	Saw blade, 116"
175-1-S	Thumb guard nut, SS	340	Star lock washer
175-2-S	Thumb screw, 1/4-20 x 1/2	360A1	Lower bearing housing angled grease fitting
177	Nylon filler	362	Bearing housing adj. cap, #6263 on
179	Wheel cleaner	415D	Stationary bar
193	Saw guide bar spring	4-30AL	Motor pulley, 5 x 3/4
196	Saw tension spring	601	Upper saw guide bracket
198	Tension pin cap	602B	Upper saw guide
200	Carriage stop movable	603	Lower guide bracket
211A-291Q	Finger lift fastener knob	604	Lower blade back-up guide
212CP	Platter rod cotter pin	653PS	Warning label
214	Side platter bracket, to #18258	661-1	Saw guard on head door
241CT	Side platter bracket, #18259 on	663	Saw guard on saw guide bar, w/708 decal
220	Carriage stop movable	708	Decal "Danger Exposed Blade"
221-???	V-belt, ADVISE SIZE	71-1	Upper wheel hinge bracket
230DL	Upper shaft seal		

COMPLETE ASSEMBLIES

AS239-B30-B	Bolt on base foot & leg assembly	A220	Carriage stop assembly, fixed
AS120S	Channel assembly, #21066 on, SS	A227	Upper bearing cup/cone assembly
A112	Head door latch assembly	A249L	Base door handle assembly, left
A116-22	Saw guide bar assembly	A249R	Base door handle assembly, right
A14L	Head door hinge assembly, lower	A262	Meat gauge release assembly
A14U	Head door hinge assembly, upper	A290CT	Lower cleaning unit assembly
A130	Steel cleaner assembly	A295	Wheel cleaner assembly
A15003U	Upper wheel assembly w/o hinge plate	A33155	Meat carriage assembly, #11530 on
A15003U335	Upper wheel assembly w/hinge plate	A33155-OS	Meat carriage assembly, to #11530
A15005	Head & door assembly	A33163	Sta. platter assembly, to #8756w/415D
A15006	Head door assembly	A33163-1	Sta. platter assembly, #8757 to #18258
A15273	Meat gauge bracket assembly, SS	A33163-2	Sta. platter assembly, #18258 on
A15335X	Hinge plate assembly	A33275	Meat gauge plate assembly
A16247	Upper shaft & bearing assembly	A363	Lower bearing cup/cone assembly
A16360	Lower bearing housing assembly, #6263 on	A415D	Stationary bar assembly
A16360-OS	Lower bearing housing assembly, to #6263	A602	Upper saw guide assembly
A19-1	Ratchet assembly	A603604	Lower blade back-up assembly
A196	Tension spring assembly	A6808-G-15	Toggle switch assembly, 1 phase
A200	Carriage stop assembly, movable	A7810-G-15	Toggle switch assembly, 3 phase

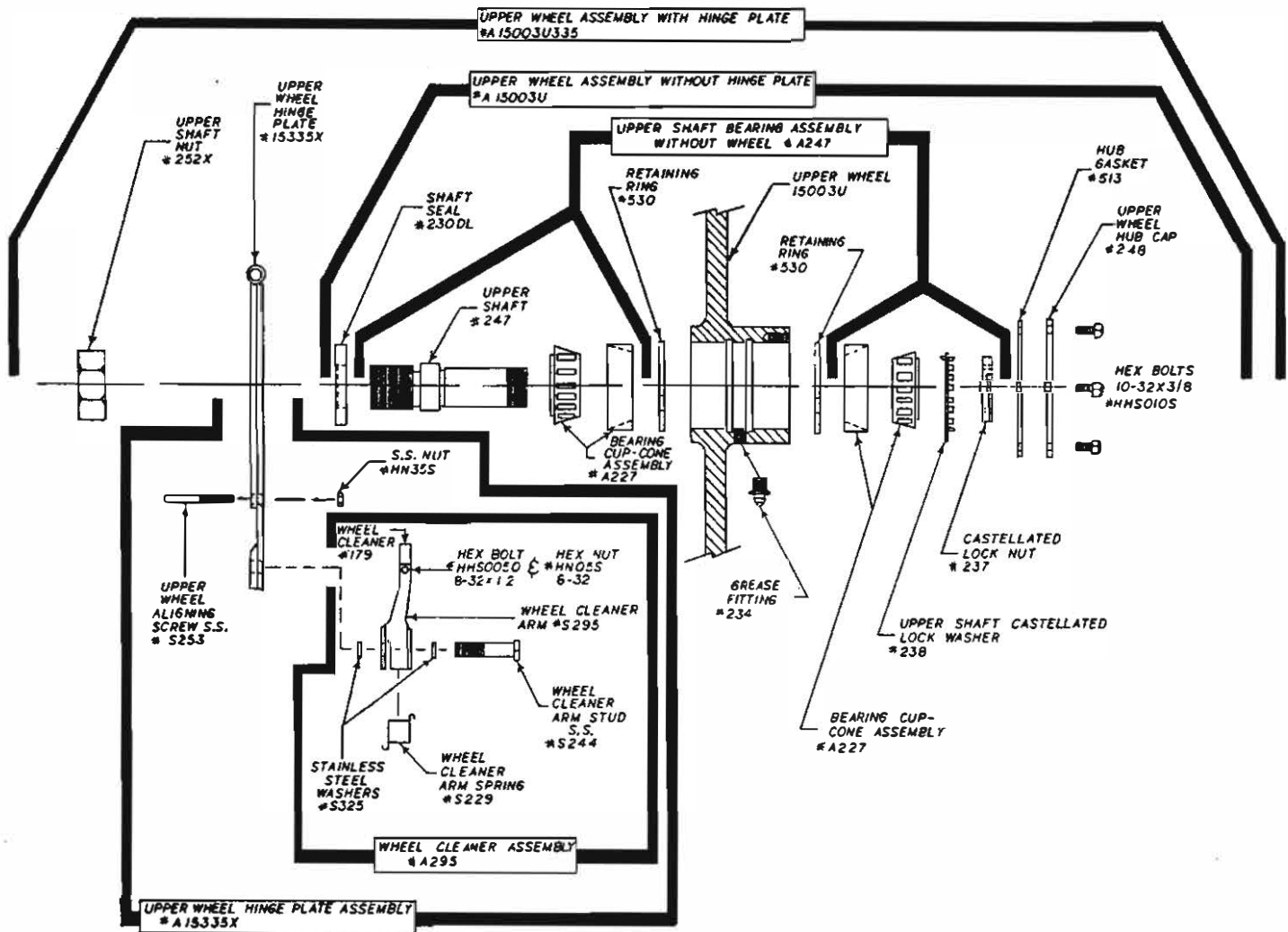

WIRING MOTOR:

- (1) Interchange of current is made in motor outlet box. Leads are properly marked. Changing instructions are on motor plate or motor outlet box.
- (2) All cutters are wired 220 volts unless otherwise specified. Be sure motor specifications (voltage, cycle, phase) match power supply line. Be sure line voltage is up to specifications.
- (3) Connect leads to machine in a manner that will be approved by local electrical inspectors.
- (4) We recommend not less than No. 12 wire, otherwise an overload condition may occur. If leads are too light machine may not have sufficient cutting power and/or speed.
- (5) The BIRO Manufacturing Company is not responsible for permanent wiring, connection or installations.

LUBRICATION:

Table Bearings: grease packed at the factory. Repack as necessary.
Meat Gauge Bar: grease every four months.
Slide Gibs: for mounting head are provided with grease fittings and should be greased every four months.
Main Bearings: grease packed at factory. Check and grease if necessary.

ADJUSTMENTS:

- (1) **Tightening Motor-Belt:** The motor drive belt can be tightened to any desired tension by removal of shims under motor.
- (2) **Saw Guides:** Should be adjusted so the guide is 1/32" from the back edge of the blade when the machine is idling. This prolongs the life of the saw wheels by reducing pressure and wear of the saw blade against the flange of the wheel.

CLEANING THE BIRO POWER CUTTER:

Sixty years of engineering and experience has been built into this BIRO cutter to make the machine easier to clean. Every part has been made accessible and easily removed without tools. No other cutter on the market comes apart for cleaning like a BIRO cutter. Each part should be removed for cleaning. To insure cleaner cuts, keep the cleaning system in good condition. Parts on the cleaning system that should be checked weekly, and changed often are as follows: wheel cleaners, upper and lower, Item No. 179; steel saw cleaners, Item No. 131; steel guide in stationary bar, Item No. 119A; upper saw guide, Item No. 602B; lower blade back up guides, Item No. 604; nylon filler, Item No. 177. See Pages 6-7 for parts identification and ordering.

SAFETY FEATURES:

- (1) The blade is controlled on the wheels by spring tension. If the blade is broken, the blade band stops turning immediately because there is no tension on the saw blade to cause motion. Never twist the cutting blade while operating. Never leave your cutter running when not in use.
- (2) The end cut (pusher) plate, Item No. 256P, supplied with each cutter should be used whenever possible and always when cutting or splitting the last slice. This insures safety and prevents injury to hands.
- (3) Saw guide bar #116-22 should be pulled down to the height of meat being cut. This power cutter meets the requirements of Underwriters' Laboratories. Do not attempt to hold meat with hands in front of blade.