

# Electric Autolift Fryer

MODELS BLF-TC

Service Manual





## BKI LIMITED WARRANTY

2812 Grandview Dr. • Simpsonville, SC 29680 • USA  
(864) 963-3471 • Toll Free: (800) 927-6887 • Fax: (864) 963-5316

### WHAT IS COVERED

This warranty covers defects in material and workmanship under normal use, and applies only to the original purchaser providing that:

- The equipment has not been accidentally or intentionally damaged, altered or misused;
- The equipment is properly installed, adjusted, operated and maintained in accordance with national and local codes, and in accordance with the installation and operating instructions provided with this product.
- The serial number rating plate affixed to the equipment has not been defaced or removed.

### WHO IS COVERED

This warranty is extended to the original purchaser and applies only to equipment purchased for use in the U.S.A.

### COVERAGE PERIOD

- Warranty claims must be received in writing by BKI within one (1) year from date of installation or within one (1) year and three (3) months from date of shipment from the factory, whichever comes first.
- COB Models: One (1) Year limited parts and labor.
- COM Models: Two (2) Year limited parts and labor. COM convection ovens also have a two (2) year door warranty.
- CO1 Models: Two (2) Year limited parts and labor. Five (5) Year limited door warranty.
- Warranty period begins the date of dealer invoice to customer or ninety (90) days after shipment date from BKI, whichever comes first.

### WARRANTY COVERAGE

This warranty covers on-site labor, parts and reasonable travel time and travel expenses of the authorized service representative up to (100) miles round trip and (2) hours travel time and performed during regular, weekday business hours.

### EXCEPTIONS

Any exceptions must be pre-approved in advance and in writing by BKI. The extended door warranty on convection ovens years 3 through 5 is a parts only warranty and does not include labor, travel, mileage or any other charges.

### EXCLUSIONS

- Negligence or acts of God,
- Thermostat calibrations after (30) days from equipment installation date,
- Air and gas adjustments,
- Light bulbs,
- Glass doors and door adjustments,
- Fuses,
- Adjustments to burner flames and cleaning of pilot burners,
- Tightening of screws or fasteners,
- Failures caused by erratic voltages or gas suppliers,
- Unauthorized repair by anyone other than a BKI Factory Authorized Service Center,
- Damage in shipment,
- Alteration, misuse or improper installation,
- Thermostats and safety valves with broken capillary tubes,
- Freight - other than normal UPS charges,
- Ordinary wear and tear,
- Failure to follow installation and/or operating instructions,
- Events beyond control of the company.

### INSTALLATION

Leveling, as well as proper installation and check out of all new equipment - per appropriate installation and use materials - is the responsibility of the dealer or installer, not the manufacturer.

### REPLACEMENT PARTS

BKI genuine Factory OEM parts receive a (90) day materials warranty effective from the date of installation by a BKI Factory Authorized Service Center.

Warranty is in lieu of all other warranties, expressed or implied, and all other obligations or liabilities on the manufacturer's part. BKI shall in no event be liable for any special, indirect or consequential damages, or in any event for damages in excess of the purchase price of the unit. The repair or replacement of proven defective parts shall constitute a fulfillment of all obligations under the terms of this warranty.

# Table of Contents

<b>Table of Contents</b> .....	<b>1</b>
<b>Introduction</b> .....	<b>2</b>
Safety Precautions.....	2
Safety Signs and Messages.....	2
Specific Precautions .....	3
Equipotential ground plane .....	3
Full Disconnection.....	3
Safe Work Practices .....	4
<b>Installation</b> .....	<b>8</b>
<b>Operation</b> .....	<b>9</b>
Start-Up (BLF-TC) .....	9
Product Programming.....	12
Set Oil Temp.....	16
Set Clock.....	17
Settings .....	18
Frying Log.....	19
Machine Log .....	20
Import/Export .....	21
Change Code.....	24
System I/O .....	25
Cap Touch .....	27
Options.....	28
Screen.....	29
<b>Maintenance</b> .....	<b>31</b>
Scheduled Maintenance .....	31
Troubleshooting .....	32
Filter Pump Reset.....	33
<b>Replacement Parts</b> .....	<b>34</b>
Assemblies.....	34
Components.....	45
Accessories.....	47
<b>Wiring Diagrams</b> .....	<b>48</b>
<b>Notes</b> .....	<b>50</b>

---

## Introduction

The BLG Fryer is compact, attractive and functional in design. It is constructed of a stainless steel fryer pot for cleaning ease. Exclusive BKI patented features and safety devices offer flexibility, efficiency and reliability plus **PERFECTION IN FRYING!**

The BKI name and trademark on this unit assures you of the finest in design and engineering -- that it has been built with care and dedication -- using the best materials available. Attention to the operating instructions regarding proper installation, operation, and maintenance will result in long lasting dependability to insure the highest profitable return on your investment.

### **NOTICE**

PLEASE READ THIS ENTIRE MANUAL BEFORE OPERATING THE UNIT. If you have any questions, please contact your BKI Distributor. If they are unable to answer your questions, contact the BKI Technical Service Department, toll free: 1-800-927-6887. Outside the U.S., call 1-864-963-3471.

### **Safety Precautions**

Always follow recommended safety precautions listed in this manual. Below is the safety alert symbol. When you see this symbol on your equipment, be alert to the potential for personal injury or property damage.



### **Safety Signs and Messages**

The following Safety signs and messages are placed in this manual to provide instructions and identify specific areas where potential hazards exist and special precautions should be taken. Know and understand the meaning of these instructions, signs, and messages. Damage to the equipment, death or serious injury to you or other persons may result if these messages are not followed.

#### **DANGER**

This message indicates an imminently hazardous situation which, if not avoided, will result in death or serious injury.

#### **WARNING**

This message indicates a potentially hazardous situation, which, if not avoided, could result in death or serious injury.

#### **CAUTION**

This message indicates a potentially hazardous situation, which, if not avoided, may result in minor or moderate injury. It may also be used to alert against unsafe practices.

#### **NOTICE**

This message is used when special information, instructions or identification are required relating to procedures, equipment, tools, capacities and other special data.

## Specific Precautions



**WARNING**

Risk of fire exists if the oil level drops below 5mm of the maximum oil level.



**WARNING**

Use of oil/shortening older than the manufacturer's recommendations for life of the oil is prone to surge boiling and flash fires. Follow the oil manufacturer's guidelines for the life cycle of oil/shortening.



**WARNING**

Do not open the drain valve or the fill valve while the fryer is in operation. Serious burns may result.



**WARNING**

Improper installation, adjustment, alteration, service or maintenance can cause property damage, injury or death. Read the installation, operation and maintenance instructions thoroughly before installing or servicing this equipment.



**CAUTION**

Follow instructions regarding effects of surge boiling of over-wet foods and proper load size.



**CAUTION**

### Equipotential ground plane

When a high current flows through a conductor, differences in potential appear between the conductor and nearby metallic surfaces near the appliance. As a result, sparks may be produced between the appliance and surrounding metal surfaces. These sparks could cause serious injury, damage, or fire.

BKI provides an Equipotential ground terminal for the connection of a bonding conductor after the installation of the appliance per IEC60417-1. This terminal is located on the inside of the Power Entry Supply box near the Earth connection and is marked with this symbol.



**NOTICE**

### Full Disconnection

In accordance with Local and/or National wiring codes, the installer must provide a means of full disconnection under over voltage Category III conditions. An IEC approved cord and plug combination will meet this requirement.

Units not provided with a cord and plug do not meet this requirement. In accordance with Local and/or National wiring codes, the installer must provide the means of full disconnection.

**NOTICE**

The fryer is designed to hold a maximum of 75lbs (34KG) of oil/shortening.

---

## Safe Work Practices



### Do Not Store or Use Anything Flammable Near the Fryer

Your fryer is powered by either natural gas or LP gas. Do not store or use gasoline or any flammable liquids or vapors near this or any other appliance. Flammable materials will burn easily. Letting any flammable liquid or vapor get too close to the fryer could cause an explosion or fire. Serious injury could result. Examples of flammables that you should not store near the fryer are gasoline, paint, thinners or removers, gas tanks, and cleaning materials.



### Beware of High Voltage

This equipment uses high voltage. Serious injury can occur if you or any untrained or unauthorized person installs, services, or repairs this equipment. Always Use an Authorized Service agent to Service Your Equipment.



### Use the Fryer on Noncombustible Floors Only

Make sure your floor is noncombustible. Do not operate your fryer on floors that are wood, carpeted or have rubber mats. Placing your fryer on a combustible floor could cause a fire. Serious injury could result. Examples of noncombustible floors where you can safely place your fryer are concrete, tile, and ceramic.



### Keep The Area Around Your Fryer Uncluttered

Make sure to keep the area around your fryer clear of any obstacles.

Serious injury can occur if you trip or fall near the fryer. You could be burned by hot shortening that splashes out of the fryer or by falling against the hot metal of the fryer.



## Keep The Floor Around Your Fryer Clean Of Shortening

Make sure to keep the floor around your fryer clean of shortening and other liquids.

Serious injury can occur if you slip near your fryer. You could be burned by hot shortening that splashes out of the fryer or by falling against the hot metal of the fryer.

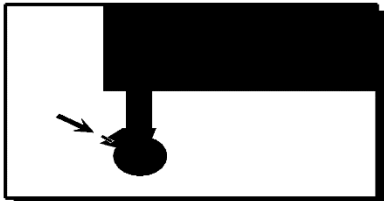

## Keep The Casters Locked

To avoid spilling shortening, keep the casters locked. If any shortening spills near your fryer, clean it up immediately.

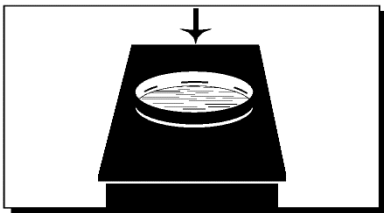

## Do Not Overfill the Fryer with Shortening

Hot shortening and steam may escape and burn you if you put too much shortening in the fryer. Fill the fryer to approximately one inch below the fill marks that are inside the fryer pot. Heat the shortening. If needed, carefully add more shortening to bring the level to the fill marks.

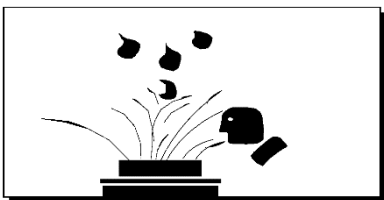

## Do Not Let Any Water Get into The Fryer

Always remove excess moisture from food before placing it into the fryer basket. Water will cause the hot shortening to spatter. You could be burned.



## Do Not Overload the Basket with Food

Hot shortening and steam may escape and burn you if you place too much food in the basket.

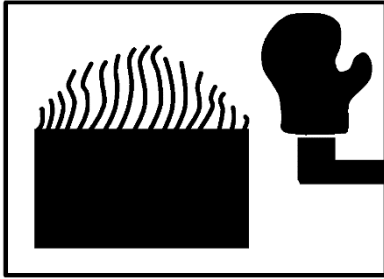

## Wear Safe Clothing Appropriate to Your Job

Always wear your insulated mitts when handling the fryer basket or touch any hot metal surfaces. You received a pair of insulated mitts with your fryer. If you lose or damage your mitts, you can buy new ones at your local restaurant equipment supply store or from your local **BKI** Distributor.

Always wear non-skid shoes when working around the fryer or any other equipment that uses shortening. Never wear loose clothing such as neckties or scarves while operating your fryer. Keep loose hair tied back or in a hair net while operating your fryer.

Always wear appropriate personal protection equipment during the filtering process to guard against possible injury from hot oil.

Always wear appropriate personal protection equipment during the boil-out process to guard against possible injury from hot cleaning solution.

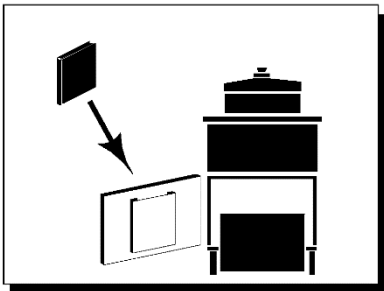

## Keep this manual with the Equipment

This manual is an important part of your equipment. Always keep it near for easy access.

If you need to replace this manual, contact:

**BKI**  
 Technical Services Department  
 2812 Grandview Drive  
 Simpsonville, S.C. 29680  
 Or call toll free: 1-800-927-6887  
 Outside the U.S., call 864-963-3471



## Protect Children

Keep children away from this equipment. Children may not understand that this equipment is dangerous for them and others.

**NEVER** allow children to play near or operate your equipment.

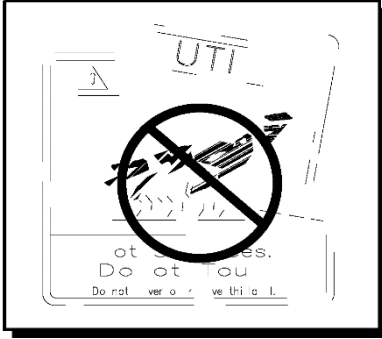

## Keep Safety Labels Clean and in Good Condition

Do not remove or cover any safety labels on your equipment. Keep all safety labels clean and in good condition. Replace any damaged or missing safety labels. Refer to the Safety Labels section for illustration and location of safety labels on this unit.

If you need a new safety label, obtain the number of the specific label illustrated on page **Error! Bookmark not defined.**, then contact:

### **BKI**

Technical Services Department  
2812 Grandview Drive  
Simpsonville, S.C. 29680  
Or call toll free: 1-800-927-6887  
Outside the U.S., call 864-963-3471

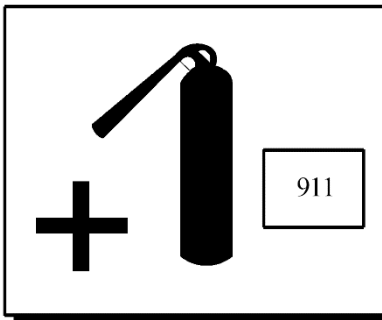

## Be Prepared for Emergencies

Be prepared for fires, injuries, or other emergencies.

Keep a first aid kit and a fire extinguisher near the equipment. You must use a 40-pound Type BC fire extinguisher and keep it within 25 feet of your equipment.

Keep emergency numbers for doctors, ambulance services, hospitals, and the fire department near your telephone.

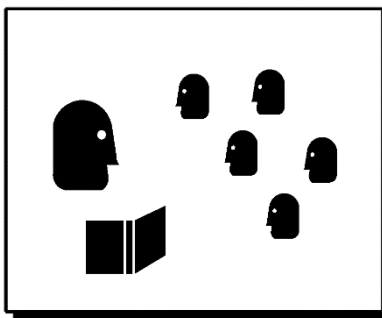

## Know your responsibilities as an Employer

- Make certain your employees know how to operate the equipment.
- Make certain your employees are aware of the safety precautions on the equipment and in this manual.
- Make certain that you have thoroughly trained your employees about operating the equipment safely.
- Make certain the equipment is in proper working condition. If you make unauthorized modifications to the equipment, you will reduce the function and safety of the equipment.

---

## **Installation**

For installation information, refer to *Gas Autolift Fryer, MODEL BLF-TC, Installation and Operation Manual*.

## Operation

### Start-Up (BLF-TC)

1. Turn fryer on by touching the **ON** button for 3 seconds.
2. Make sure the main drain valve is closed.



3. Fill pot with shortening to above the "MIN OIL LEVEL" mark.

#### **WARNING**

Risk of fire exists if the oil level drops below the minimum oil level. The level of oil within the pot must not fall below 5mm of the maximum oil level.

#### **WARNING**

Use of oil/shortening older than the manufacturers recommendations for life of the oil is prone to surge boiling and flash fires. Follow the oil manufacturers guidelines for lifecycle of oil/shortening.

#### **CAUTION**

Overfilling the fryer pot with shortening could lead to serious injury. Ensure that the fryer pot is filled with shortening only to the fill mark when shortening is hot. Do not use any shortening other than what is specified in this manual and do not overfill the fryer pot.

#### **CAUTION**

The fryer has a maximum temperature setting of 375° F/191° C. Do not use oil/shortening with a flashpoint less than 554° F (290° C)

#### **NOTICE**

Use only high-quality shortening that has low moisture content, a high smoke point and no additives.



- Once the fryer is filled with shortening, press the **FRY** button.

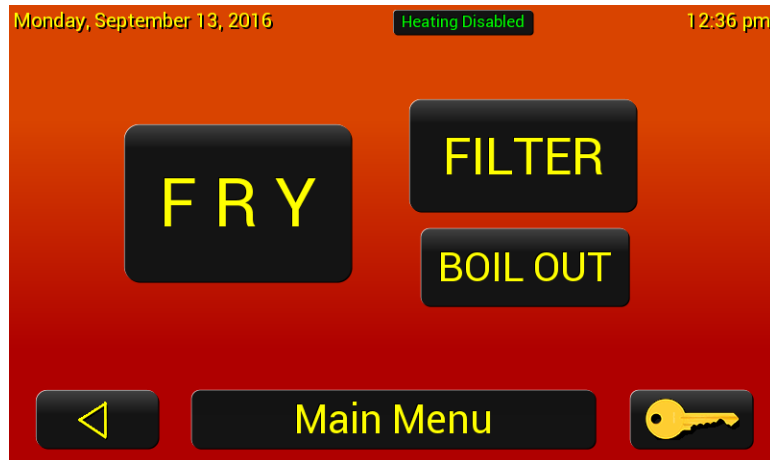

- Confirm the oil level by pressing the green check mark.



- The fryer will start heating up by going into a melt cycle. It will pulse the elements until the oil gets to 225° F (107° C) and then goes into heat mode until it reaches the setpoint temperature. The recipes will be greyed out and inaccessible until the fryer reaches setpoint temperature. (If the burner does not light and you get a **Gas Alarm**, see the Gas Alarm instructions in the Troubleshooting section.)



7. When the fryer is ready to cook the recipes will be activated.

**IMPORTANT!** Before the first cooking operation each day, stir the shortening freely while it is heating to provide a balanced shortening temperature for excellent results with the first cooking. Failure to do this can result in a crusty skin on the product surface with an undercooked product internally. In addition, in some cases, failure to stir the shortening while it is initially heating may cause the HI-LIMIT safety device to disable the power due to a false overtemperature condition.

## Product Programming

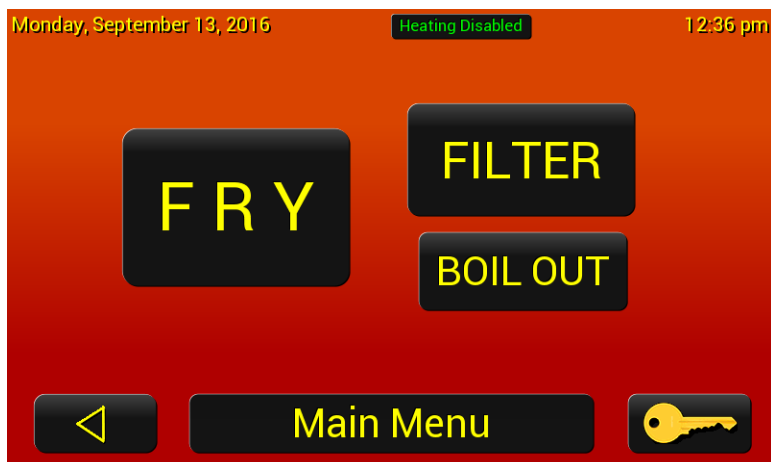

1. Press the Key button to get into the settings menus.



2. Enter code **1234** and then press the green check mark.



3. Select the **Edit Recipe** button



4. Select the Recipe that needs edited.



5. In the Edit Recipe screen the name, cook time, temperature, timing type, & picture can be edited.



6. Select **Name** to change the name and press the green check mark to save.



7. Select **Frying** to edit the time and temperature of the recipe. Press the green check mark to save.



8. Pressing the **Next** button will bring you to the second page where the shake/stir, alarm, if the program is active, and the filter weight can be edited.



9. Press the **Shake/Stir** time to edit the time & number of beeps. Press the green check mark to save.



10. Press the alarm time to edit the time. Press the green check mark to save.



11. Set the basket lift start position, make sure the program is active and set the filter weight (1.0-12.0 by 0.5 increments, if using global filtering).
12. When done, press the **SAVE** button to save the program.



13. If you want to cancel the recipe or accidentally press the back button, the message above will display. You can save by pressing the SAVE or cancel by pressing the back arrow.

## Set Oil Temp



1. Get into the supervisor menu and select the **Set Oil Temp** button

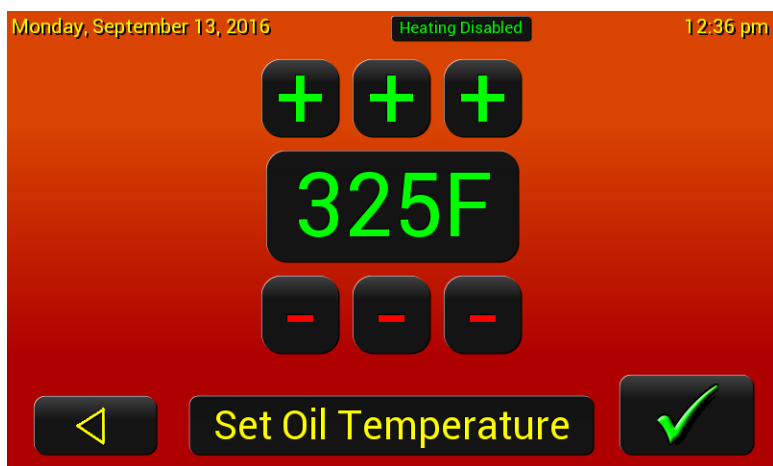

2. Set the oil temperature to the desired ready to cook temperature between 250° F and 375° F.
3. Press the green check mark to save.

## Set Clock



1. Get into the supervisor menu and select the **Set Clock** button



2. Set the date & time.
3. Press the green check mark to save.

## Settings



1. Get into the supervisor menu and select the **Settings** button



2. Set the Beeper Volume (Low or High), Pattern (1, 2, or 3), the Filter Lockout\* can be turned off & on, the Filter Lockout Value can be set (2-20), and the Temperature Units can be set (C or F).  
\*The filter lockout is a global counter used to determine when to force filter. Set the total filter value in settings and then in the recipes, the weight of each recipe can be set. (i.e. Fresh breaded product can have a value of 3 and french fries a value of 1.) When the values of the recipes cooked adds up to the global value (or over), the control will require a filter.
3. Press the green check mark to save.

## Frying Log



1. Get into the supervisor menu and select the **Frying Log** button



2. The frying log will record the following events:
  - Recipe Cooked with elapsed time and average temperature
  - Basic Filter with filtering time, refill time, and number of pump lockouts
  - Filter With Rinse Hose with filtering time, refill time, and number of pump lockouts
  - Boil Out with heating time
3. Press the back button  to exit.

## Machine Log



4. Get into the supervisor menu and select the **Machine Log** button



5. The frying log will record the following events:
- Touchscreen Error
  - Probe Error
  - Nonvolatile Memory read, write, or data errors
  - Factory Reset
  - Touchscreen Calibration
  - Configuration Change
  - Password Error
  - Password Reset
  - Password Change
  - Recipe Saved
  - Recipes Imported
  - Recipes Exported
  - Configuration Import
  - Configuration Export
  - Frying Log Export
  - Machine Log Export
  - USB Drive read, write, and file open errors
  - Touch Configuration Change
  - Fryer Options Changed
  - Firmware Update
6. Press the back button  to exit.

## Import/Export



1. Get into the supervisor menu and select the **Import/Export** button



2. Insert a USB drive.



3. Press the import/export recipes button to save the recipes to a USB or copy to the fryer.



1. To add up to 8 additional Recipe Icons, press the **Import Icons** button with the USB inserted.
2. Importable Image Requirements:
  - a. JPG images only, standard 24 bit color with any amount of image compression.
  - b. Recipe icons must be 64 pixels wide and 64 pixels tall.
  - c. The maximum file size is 54k bytes.
  - d. File names can be any combination of letters and numbers up to a maximum of 8 characters, the extension must be “.jpg”. The name is case insensitive.
3. Touch the **Find Files ...** button, the controller will look through the entire USB drive and find all jpg files which are 64x64 pixels and below the maximum file size, displays the file name and image of the first file found meeting those criteria, and shows the number of files found in the **Find Files ...** button. The 8 locations to the right will now be available, locations which already have an icon stored in them will display the stored image. Use the up and down arrows to scroll through all the files the controller found until the file wanted is displayed.
4. Select the location in which they want to store the icon, they can choose any of the eight locations including those which are already in use, that location will be overwritten. The selected location button turns green and the green check button is now available. Touching the green check button stores the selected image into that location in the controller image format along with the name and size of the file and the original jpg file data so it can be exported at some other time.
5. When the import is completed the controller chirps twice indicating that it has stored that icon. Select other icon files and other icon locations and store as many of the images as desired.
6. Press the back button  to exit.



1. To copy any or all 8 Recipe Icons, press the **Export Icons** button with the USB inserted.
2. The eight button on the left side display all the imported user icons. Select or deselect any of the 8 images to be exported just by touching the icon buttons. Touch once to select, touch again to deselect. The **Select All** button can be used to select all imported icons.
3. Touch the green check button to export all of the selected icons with their original file names and data to the USB drive. NOTE: Files already on the flash drive which have the same name as the original files will be overwritten with the stored image data.
4. Press the back button  to exit.

## Change Code



1. Get into the supervisor menu and select the **Change Code** button



2. Enter the new 4 digit access code. We recommend an easy to remember number, like the store number.
3. Press the green check mark to save.

## System I/O



1. Enter code 5142 and then pres the green check mark to get into the technician menus.



2. Select the **MORE** button.



3. Select the **System I/O** button.

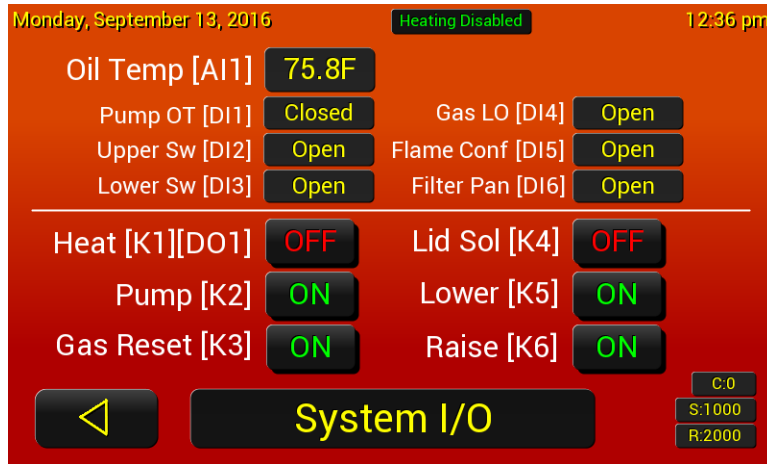

4. The **System I/O** let you see which out puts are open or closed and the oil temperature. The text in the yellow are the state of the output.

The bottom half of the screen are inputs and the individual components can be turned off and on by pressing the associated button. This can be used to aid in the troubleshooting of the components.



**WARNING**

Do not turn on Heat [K1][DO1] without the elements being fully covered with oil or water. Damage to the elements and/or fryer may occur.

## Cap Touch



1. Select the **Cap Touch** button to configure and callibrate the touch screen.



2. The screen sensitivity can be adjusted by using the +/- buttons. Also, the glass thickness can be changed to fine tune the sensitivity.

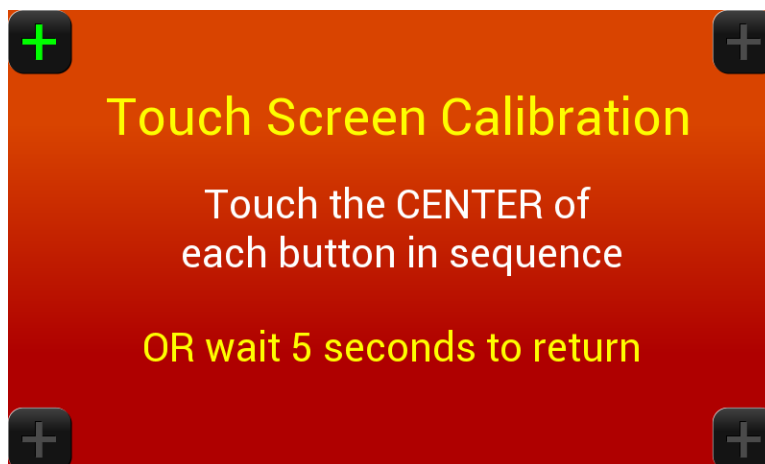

3. To calibrate the screen, press the **Calibrate Touch** button and follow the instructions on the screen.

## Options



1. Select the **Options** button to configure the control for the type of fryer you have.

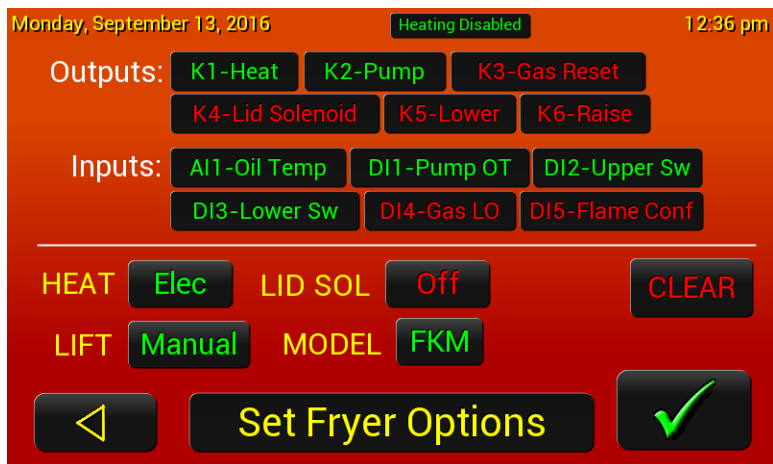

2. The “Outputs” & “Inputs” indicates what is active (green) and inactive (red).
3. Set the fryer up using the **HEAT, LID SOL, LIFT, & MODEL** buttons.
  - a. **HEAT:** Elec or Gas
  - b. **LID SOL:** On (pressure fryer) or Off
  - c. **LIFT:** None or Manual (lift assist) or Auto (auto lift fryer)
  - d. **MODEL:** Type in the model of fryer
4. Press the green check mark to save.

## Screen



1. Select the **Screen** button to configure the background color and the splash screen logo.



2. Insert the USB flash drive containing the files if you want to import images.
3. Changing the Background - The Background button has the following options, touch the button to toggle between them and see how they look:
  - a. **BKI Image** – Displays the standard BKI background image.
  - b. **Imported** – Displays the imported image if present. Touch the [Import Background] button and the controller imports the BGROUND.RAW image and displays it. The progress bar will show the importing process.
  - c. **Black** – Displays a solid black background
  - d. **Dk Grey** – Displays a dark grey background
  - e. **Dk Red** – Displays a dark red background and screen title bar
  - f. **Dk Green** - Displays a dark green background and screen title bar
  - g. **Dk Blue** - Displays a dark blur background and screen title bar
  - h. **Gradient** – Displays an orange to red gradient background
4. Keep touching the Background button and it will wrap around to the beginning of the list.
5. Changing the Splash Logo - The Splash Logo button has the following options:
  - a. **BKI Logo** – Displays the standard BKI logo in the splash screen
  - b. **Imported** – Displays the imported logo in the splash screen

- Before importing the logo you must set the image width and height. If the width and height shown in the button below the **Import Logo** button are not correct touch the [W x H] button and the following window appears:



- Use the [+] and [-] buttons to set the image width and height and then touch the green check mark button to save the new values and return to the Screen Settings window.
- Once the image size has been set touch the **Import Logo** button and the LOGO.RAW file will be imported and stored along with the image size. The progress bar will show the importing of the file data.
- Press the green check mark to save.

## Maintenance



Failure to comply with the maintenance below could result in a serious accident.

Your fryer will need periodic maintenance and servicing. We strongly suggest that you use only a service company that is authorized by BKI to do this work.

The BLF appliance is not intended to be cleaned with a water jet.

The restraining device must always be connected when the appliance is in service. Disconnect for movement, such as servicing or cleaning. Reconnect the restraint when fryer has been returned to its normal position.

### Scheduled Maintenance

Use the following table to help manage scheduled maintenance activities.

FREQUENCY	PERFORMED BY	PART	ACTIVITY
<b>Daily</b>	User	Filter Pad	Replace filter pad. Refer to the procedure in this manual.
	User	Filter system	Filter the shortening using the procedure in this manual.
<b>Weekly</b>	User	Fryer Pot	Perform the boil-out procedure in this manual.
<b>Every 6 Months</b>	Authorized BKI service agent	Connections, Fittings	Check for leakage while oil is pumping.
	Authorized BKI service agent	Fryer Pot Fittings/Connections	Check for leakage around fry pot top deck and fittings (heaters, hi-limit, thermostat, etc.).

## Troubleshooting

Refer to the table below for troubleshooting information.

Problem	Cause	Possible Solution
<b>Shortening Heating Too Slowly</b>	Low voltage or improper voltage	Contact an authorized BKI service agent for corrective action.
	Bad thermostat or loose wires	Contact an authorized BKI service agent for corrective action.
	Weak heating elements or heating elements breaking down	Contact an authorized BKI service agent for corrective action.
	Coil on contactor is bad	Contact an authorized BKI service agent for corrective action.
	Breading build-up on heating elements	Clean heating elements. If problems persist, contact an authorized BKI service agent for corrective action.
<b>Filter System Not Working</b>	Uncertain	Press the hi-limit reset button under control panel. If problems persist, contact an authorized BKI service agent for corrective action.
	Connections not tight	Tighten the connections. If problems persist, contact an authorized BKI service agent for corrective action.
	Filter valve not open	Contact an authorized BKI service agent for corrective action.
	Filter paper on screen clogged with crumbs	Change filter paper. If problems persist, contact an authorized BKI service agent for corrective action.
	Motor hums, but does not pump	Check for clogged pump. If problems persist, contact an authorized BKI service agent for corrective action.
	Motor and pump coupling worn	Contact an authorized BKI service agent for corrective action.
	No power to control panel	Make sure drain valve is completely closed. If problems persist, contact an authorized BKI service agent for corrective action.
	<b>Computer Hangs</b>	Computer malfunction.

## Filter Pump Reset

If the filter pump overheats a PUMP TOO HOT alert will pop up and a timer will start to count up.



Once the pump has cooled, the screen will indicate that the pump is ready. Press the green Check Mark to start the pump back up.

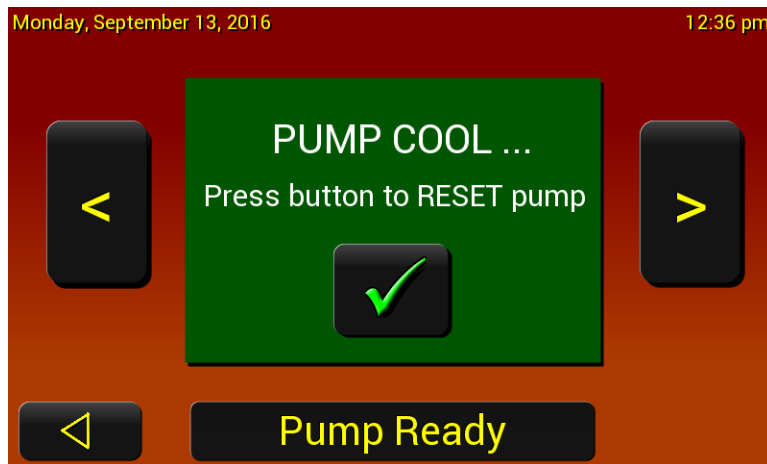

## Replacement Parts

Use the information in this section to identify replacement parts. To order replacement parts, call your local BKI sales and service representative. Before calling, please note the serial number, model number, gas type, and voltage on the rating tag affixed to the unit.

### Assemblies

Description	Assembly #	Figure #	Table #
DOOR ASSEMBLY	AB16202100	Figure 1	Table 1
DRAIN/MOTOR/PIPING ASSEMBLY	N/A	Figure 2	Table 2
FRONT PANEL BLF-TC	AN19112700	Figure 3	Table 3
COMPONENT PANEL BLF-TC	AN16029600	Figure 4	Table 4
RELAY ENCLOSURE ASSEMBLY	AB16027700	Figure 5	Table 5
OIL VAT ASSEMBLY	<a href="#">AN16010200</a>	Figure 6	Table 6
QUICK DISCONNECT ASSEMBLY	<a href="#">AN19103300</a> <a href="#">SB1997S</a>	Figure 7	Table 7
STORAGE COVER ASSEMBLY (OPTIONAL)	<a href="#">AN16007300</a>	Figure 8	Table 8

Figure 1. Door Assembly

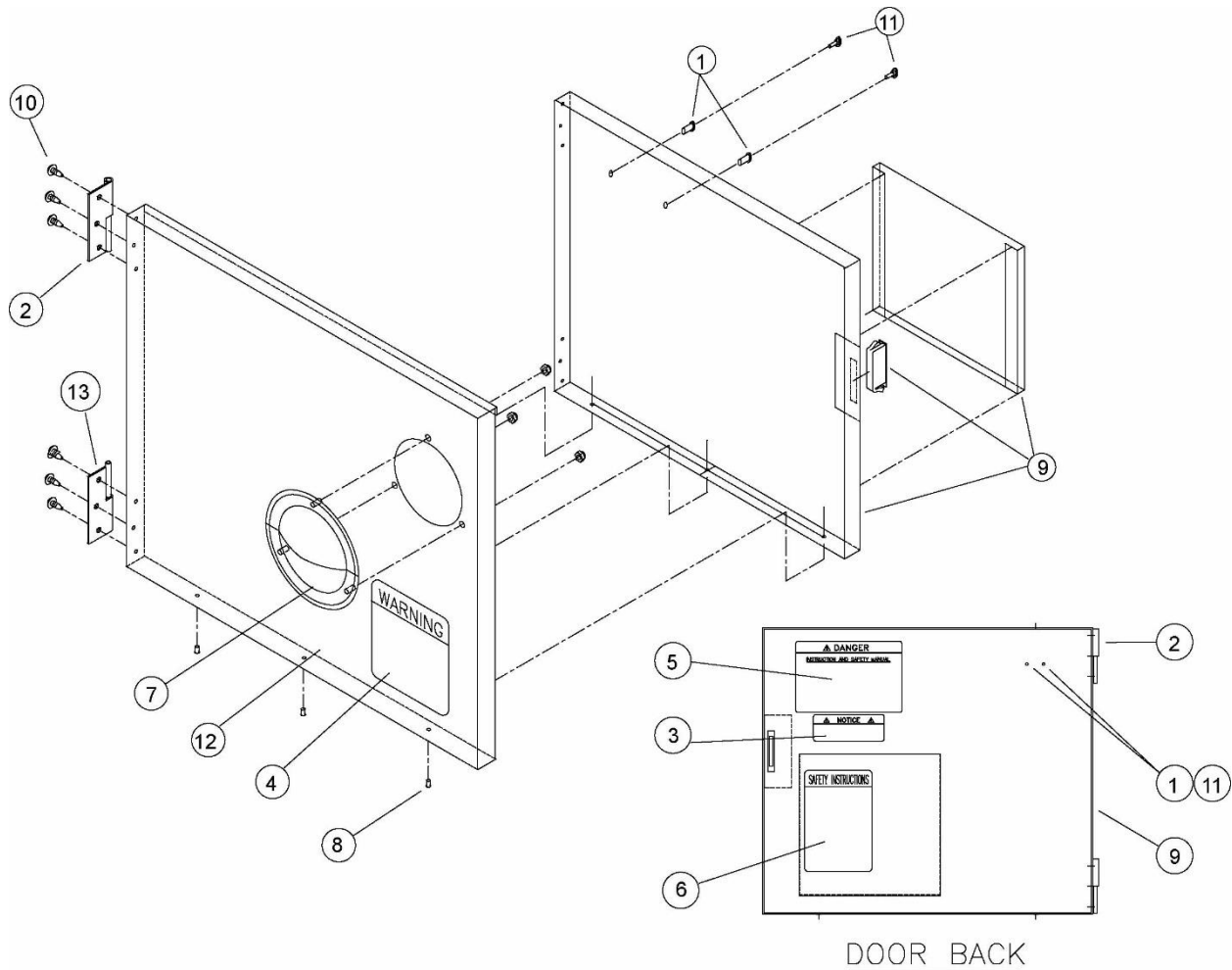

Table 1. Door Assembly Parts

ITEM #	PART #	QTY	DESCRIPTION
1	F0083	2	THREAD INSERT 10-24 STEEL
2	H0010	1	HINGE, LH PIN HALF
3	N0165	1	DECAL, NOTICE LOST MANUAL
4	N0175	1	DECAL, SLIPPING ADMONITIONS
5	N0176	1	DECAL, INSTR & SAFETY MANUAL
6	N0527	1	DECAL, SAFETY INSTR FRYERS
7	P0022	1	HANDLE, PULL SS P60-1010
8	RIV172	3	RIVET, 1/8 X 1/4 CS PLT POP
9	SB1951	1	INSIDE DOOR POCKET/MAGNET WELD BLF
10	SCR008	6	SCREW, 10 X 1/2 PHIL TRUSS HD
11	SCR383	2	SCREW, 10-24 X 1/2" PHIL TRUSS HD
12	WFKMA178	1	DOOR, FRYER OUTSIDE WELD
13	H0009	1	HINGE, RH PIN HALF

Figure 2. Drain/Motor/Piping Assembly

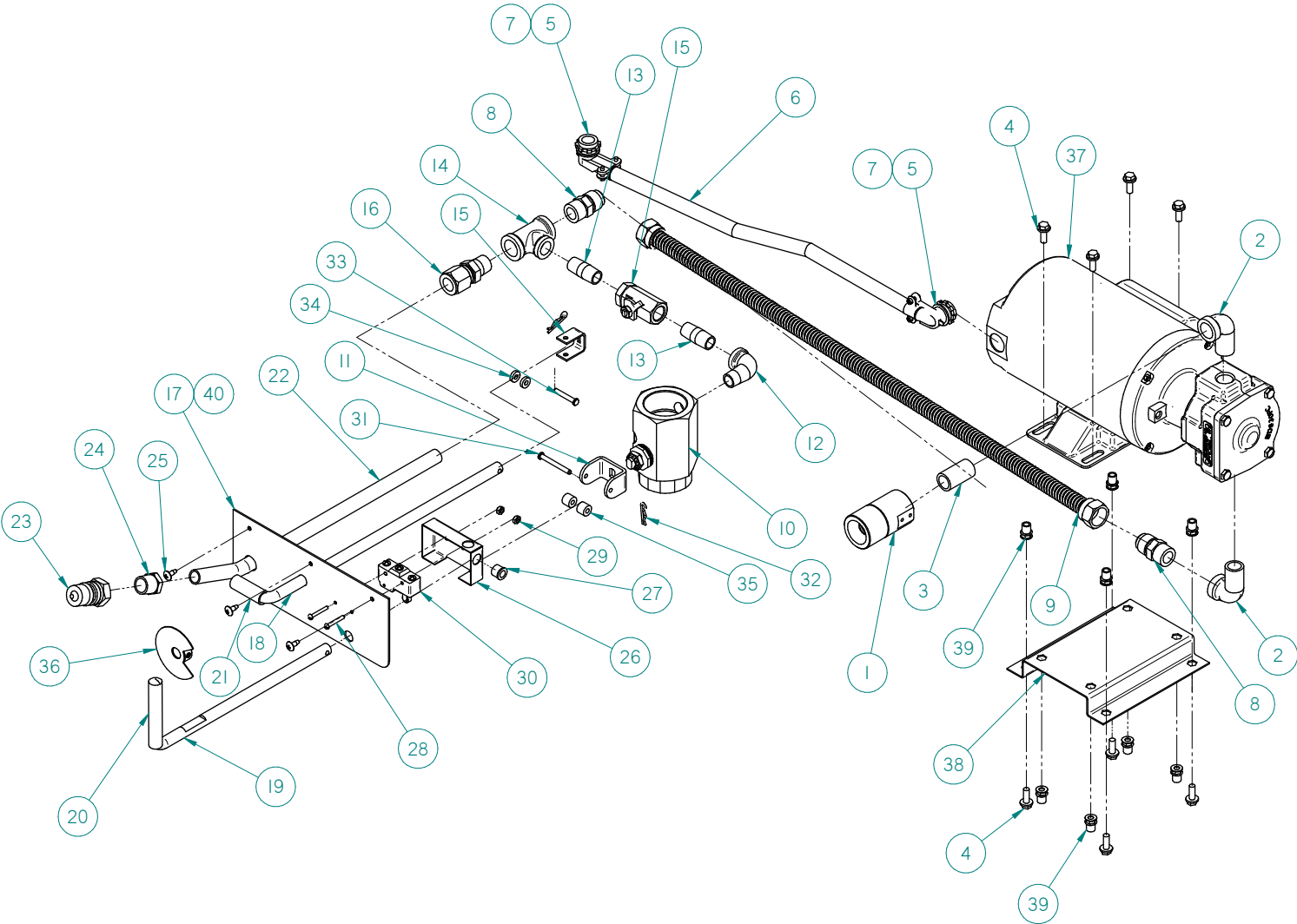

Table 2. Drain/Motor/Piping Assembly Parts

ITEM #	PART #	QTY	DESCRIPTION
1	AB15507900	1	ASSEMBLY, PUMP DISCONNECT, FILTER VAT, FKG/BLG
2	FT0312	2	ELL, STREET 1/2 90 DEG BLACK
3	FT0619	1	NIPPLE, 1/2" x 1-1/2" LG, SS 304
4	SCR463	8	SCREW, 1/4-20 X 5/8, HEX SER FLNGD
5	FT0153	2	CONNECTOR, BOX 3/8 X 90
6	LPFFA035	1	CONDUIT, 3/8" FLEX 17"
7	F0312	2	BUSHING, CONDUIT 3/8" PLASTIC
8	FT0536	2	COUPLING, 5/8" 45° FLARE TO 1/2" MPT STRAIGHT ELECTROLESS NICKEL
9	TU0206	1	TUBING, 29" 1/2" ID
10	D0060	1	VALVE, DRAIN, SS BALL & PLT. CAR. STEM
11	FT0543	1	DRAIN VALVE BRACKET FRYERS
12	FT0044	1	ELL, STREET 3/8 90 DEG, BLACK
13	FT0412	2	NIPPLE, 3/8" NPT x 1 1/2" SCH 40 BLACK PIPE
14	FT0538	1	TEE, 1/2" x 1/2" x 3/8", BLACK PIPE
15	SB1314	1	BALL VALVE ASSY, FRYERS
16	FT0507	1	CONNECTOR, MALE 10FBU-S, NICKEL PLATED 5/8" TUBE TO 1/2" NPT
17	FKMA224	1	HANDLE SUPPORT PLATE FKM
18	MA19100508	1	FILL VALVE HANDLE
19	H0215	1	DRAIN VALVE HANDEL FKM & BLF
20	C0672	1	COVER, DRAIN HANDLE RED
21	C0668	1	COVER, FILL HANDLE BLACK
22	MA19100800	1	TUBING, TEE TO DISCONNECT FKM
23	P0081	1	PLUG, D-H4F4-SV-8, QUIK DISCONNECT
24	B0851	1	BUSHING, BLACK HEX REDUCING 1/2 x 3/8 NPT 150LB
25	SCR138	3	SCREW, #10 X 1/2" PHIL TRUSS HD
26	LZ0130	1	COVER, MICROSWITCH FKM & BLF
27	F0158	1	BUSHING, BLK 1/2 HEYCO SNAP
28	SCR194	2	SCREW, 6-32 x 1" RND HD, ZINC SLOTTED
29	NUT253	2	NUT, 6-32 S/S 18-8 NYLON
30	S0054	1	SWITCH, MICRO BZ-2RW822-A2
31	F0253	1	PIN, CLEVIS, 3/16 x 1 3/4
32	F0254	2	PIN, COTTER HAIRPIN #213 .080 WIRE DIA
33	F0255	1	PIN, CLEVIS, 3/16 x 1-1/4
34	SP0014	2	SPACER, ALUM .5 X .125
35	SP0034	2	SPACER, DRAIN VALVE BRKT FRYERS
36	WB19315400	1	WELDMENT, FILL HANDLE INDICATOR
37	M0121	1	MOTOR W/PUMP, 115-208/230/50-60Hz
38	FB19313405	1	BRACKET, PUMP MOTOR MOUNT, FKG/BLG
39	F0140	8	AVK, HEX INSERT, 1/4"-20
40	N0695	1	DECAL, DRAIN HANDLE PLATE, FKM

Figure 3. Front Panel BLF-TC

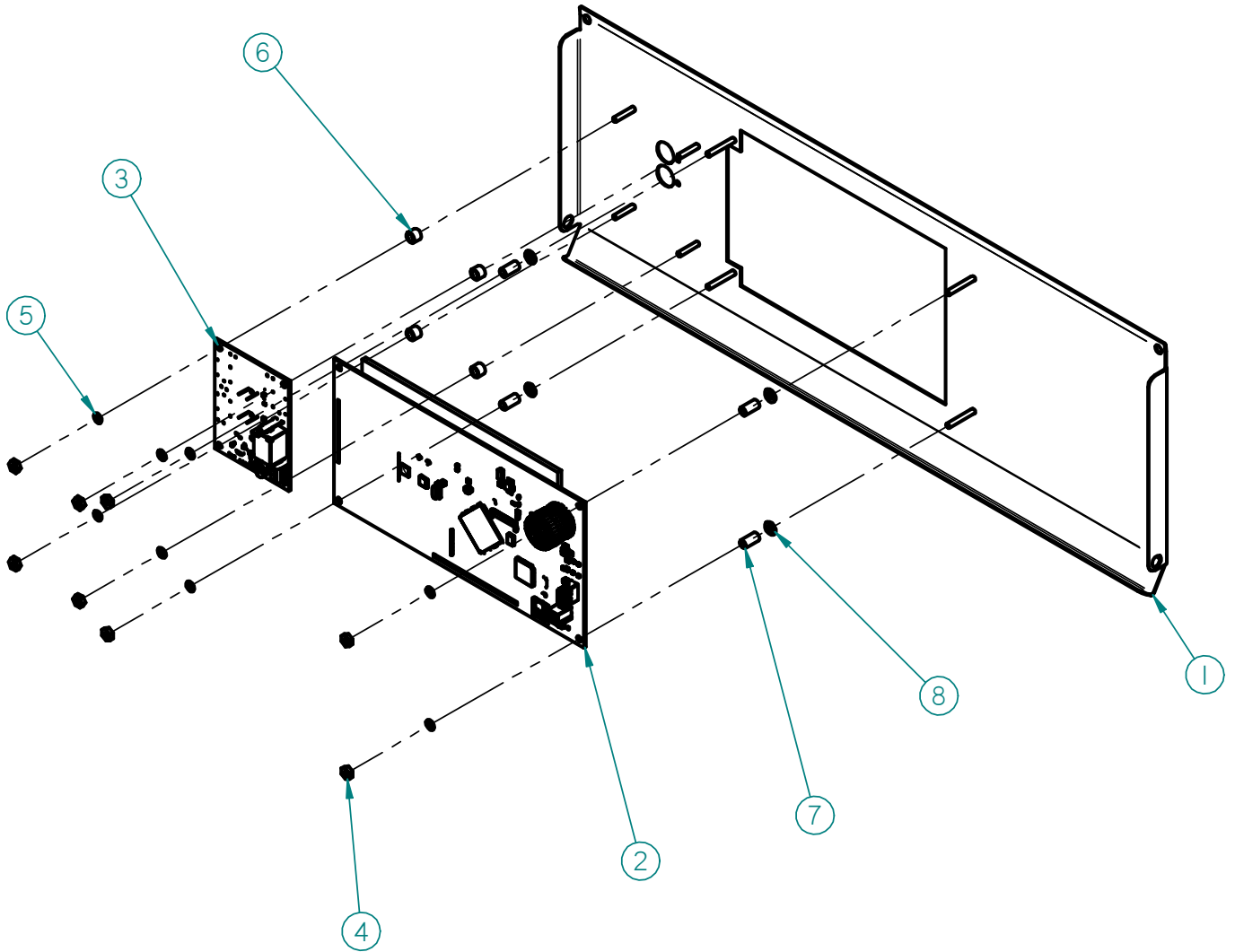

Table 3. Front Panel BLF-TC Parts

ITEM #	PART #	QTY	DESCRIPTION
1	FB19112600	1	STUD ASSEMBLY, CONTROL PANEL, TOUCH SCREEN
2	CP0117	1	CONTROLLER, TOUCH SCREEN, FRYER
3	S0712	1	SWITCH, CAPACITIVE TOUCH, 2-BUTTON, ON/OFF
4	NUT048	8	NUT, 6-32 HEX ZINC PLTD
5	WSH089	8	WASHER, #6 INT LOCK ZINC PLATED
6	SP0052	4	SPACER, 5/16 OD, 1/4 L, #10 ID ALUMINUM
7	SP0013	4	SPACER, FOR #8 X 1/2" LG.
8	WSH271	4	WASHER, #8 FLAT S/S
9*	N0702	1	DECAL, CONTROL PANEL, FRYER, TOUCH SCREEN
10*	T0184	1	PROBE, TEMPERATURE, 100 OHM RTD
11*	FT0286	1	THERMOCOUPLE FITTING W/FERRULE & NUT
12*	FT0287	1	BUSHING, REDUCING 3/8" x 1/8"

\* Not Shown

Figure 4. Component Panel BLF-TC

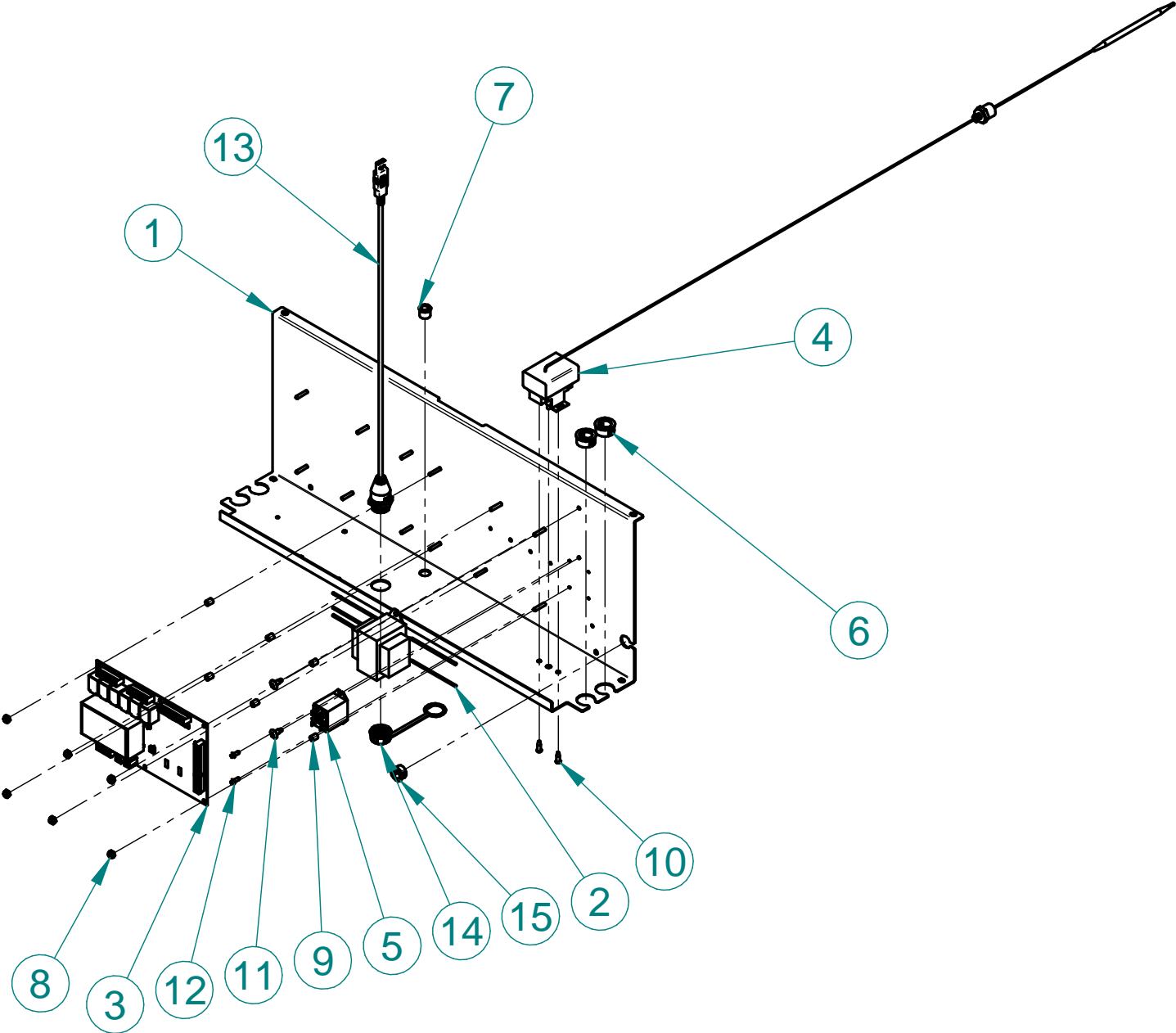

Table 4. Component Panel BLF-TC Parts

ITEM #	PART #	QTY	DESCRIPTION
1	FB16027810	1	CONTROL PANEL, TC & AFS FRYERS
2	TF0054	1	TRANSFORMER ASSY 240V
3	CP0118	1	BOARD, POWER RELAY, I/O
4	T0036	1	THERMOSTAT, HI LIMIT 540 DEG
5	R0196	1	RELAY, DPDT, 220/240V, FLANGE MOUNT
6	F0155	2	BUSHING, 7/8" SNAP (BLACK)
7	F0158	1	BUSHING, BLK 1/2 HEYCO SNAP
8	NUT253	6	NUT, 6-32 S/S 18-8 NYLON
9	SP0047	6	SPACER, .250 OD x .312 L x #6 ID, NYLON
10	SCR006	2	SCREW, 8 X 1/2 PHIL PAN TYPE "B" NKL PLTD
11	SCR138	2	SCREW, #10 X 1/2" PHIL TRUSS HD
12	SCR444	2	SCREW, 6 x 3/8" PAN HD, ZINC
13	USB001	1	CORD, USB, WATERPROOF, PANEL MOUNT, FEMALE-MALE, 0.5 M LONG
14	USB002	1	CAP, USB
15	F0156	1	BUSHING, 5/8" SNAP (BLACK)
16	F0154	1	BUSHING, BLACK 1-3/16 HEYCO SNAP
17*	S0063	1	SPRING GUARD, 6 1/2" FRYERS
18*	HF0013	2	CLAMP, HOSE, #62M10

\* Not Shown

Figure 5. Relay Enclosure Assembly

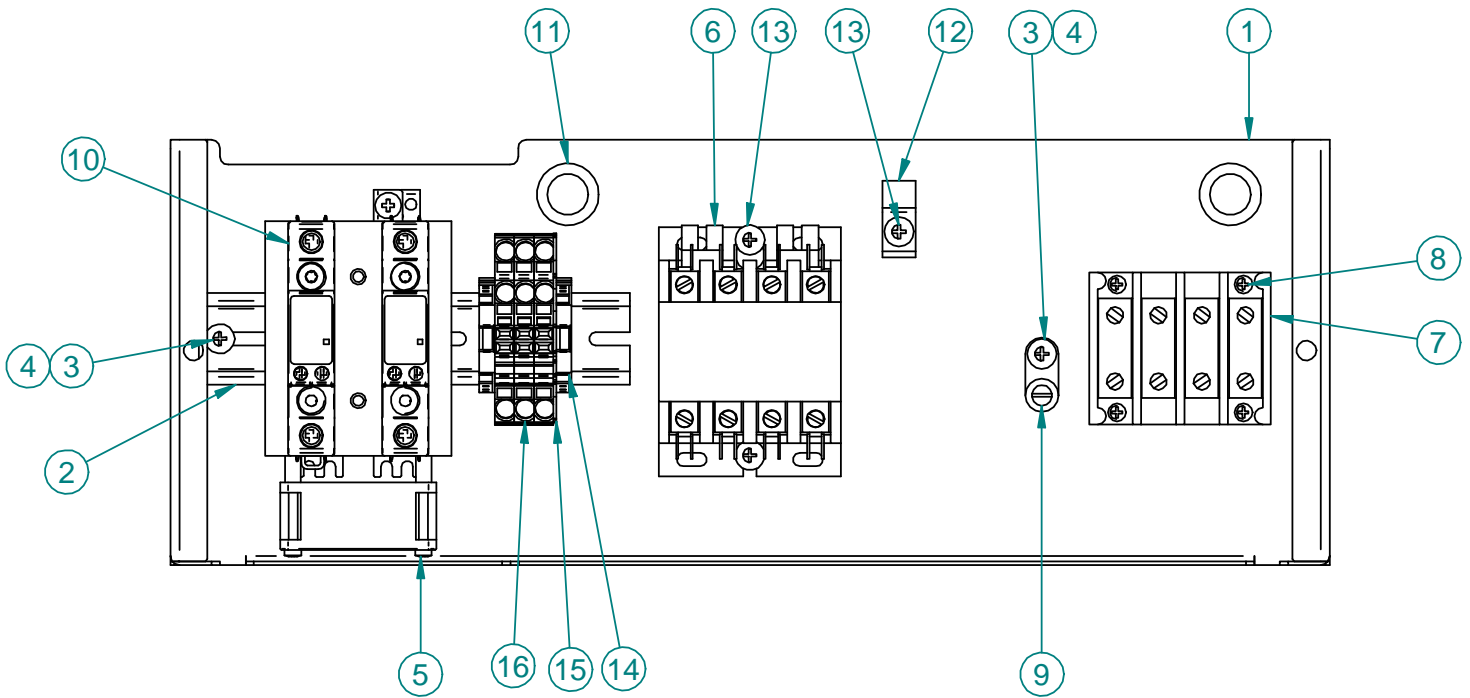

Table 5. Relay Enclosure Assembly Parts

ITEM #	PART #	QTY	DESCRIPTION
1	FB16022903	1	ENCLOSURE, RELAYS
2	MB55150900	1	DIN RAIL, 35mm x 6.50 in.
3	SCR383	3	SCREW, 10-24 x 1/2" TR HR, SS
4	NUT286	3	NUT, #10-24 KEPS, ZINC PLATED STL
5	FN0058	1	FAN, 230V, 50/60Hz, 60MM, AXIAL
6	R0150	1	RELAY, 4 Pole, 40A, 208-240V, DP
7	TB0125	1	TERMINAL BLOCK, 4 Pole, 2-14 AWG
8	SCR006	4	SCREW, 6 x 1/2" PAN HD, ZINC
9	F0111	1	GROUND TERMINAL, SINGLE HOLE
10	R0195	2	RELAY, SSR, 20-275V, 90A, 1PH
11	F0155	2	BUSHING, 7/8" SNAP (BLACK)
12	F0318	1	CLAMP, 3/8" SAFETY
13	SCR138	3	SCREW, 10 x 1/2" TR HD, ZINC
14	TB0109	2	TERMINAL BLOCK END STOP
15	TB0004	1	TERMINAL END PLATE, 3 x 8 AWG
16	TB0003	3	TERMINAL BLOCK, 3 x 8 AWG



**Table 6. Oil Vat Assembly Parts**

ITEM #	PART #	QTY	DESCRIPTION
	AN19313000	1	FILTER SCREEN ASSY,FKG
1	WB16010600	1	WELDMENT, FILTER VAT QUICK DISCONNECT
2	WB16022100	1	WELDMENT, FILTER TUBE, BLF
3	FS0002	1	FILTER SCREEN, INTERCEPTOR
4	FS0003	1	FILTER SCREEN, TOP
5	FS0001	1	FILTER SCREEN, BOTTOM
6	SB7659	1	FILTER SCREEN FITTING SPOTWELD
7	FC0004	1	NUT SCREEN RETAINING FKM-F & FKM-FC
8	O0013	1	O-RING, FLUOROCARBON V680-70
9	SCR344	1	SCREW, SET, SOC, 8-32 X 1/4
10	SB7675	1	CRUMB BASKET WELD, LG VAT ASSY
11	FB19312904	1	COVER, FILTER VAT, SHEET METAL FRAME
12	N0395	1	DECAL, VAT COVER SAFETY WARN
13	N0694	2	DECAL, CAUTION, SHARP EDGES

**Figure 7. Quick Disconnect Assembly**

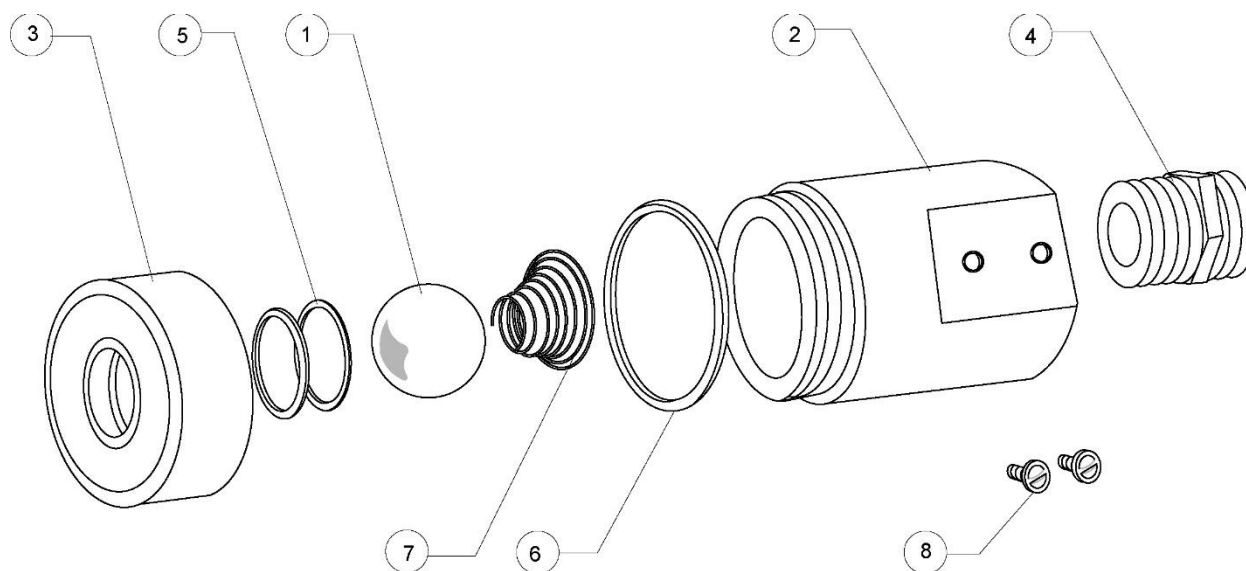

**Table 7. Quick Disconnect Assembly Parts**

ITEM #	PART #	QTY	DESCRIPTION
1	B0996	1	BALL, 11/16" STEEL BEARING
2	FT0429	1	QUICK DISCONNECT, PUMP SIDE
3	FT0500	1	QUICK DISCONNECT, VAT SIDE
4	FT0536*	1	COUPLING, 5/8 45° FLARE TO
5	O0013	2	O-RING, FLUOROCARBON V680-70
6	O0014	1	O-RING, PARKER #2-124 LARGE
7	S0138	1	SPRING, FOR QUICK DISCONNECT
8	SCR453*	2	SCREW, #10 24X3/8" WASHERED

\* - Not included with SB1997S

Figure 8. Storage Cover Assembly (Optional)

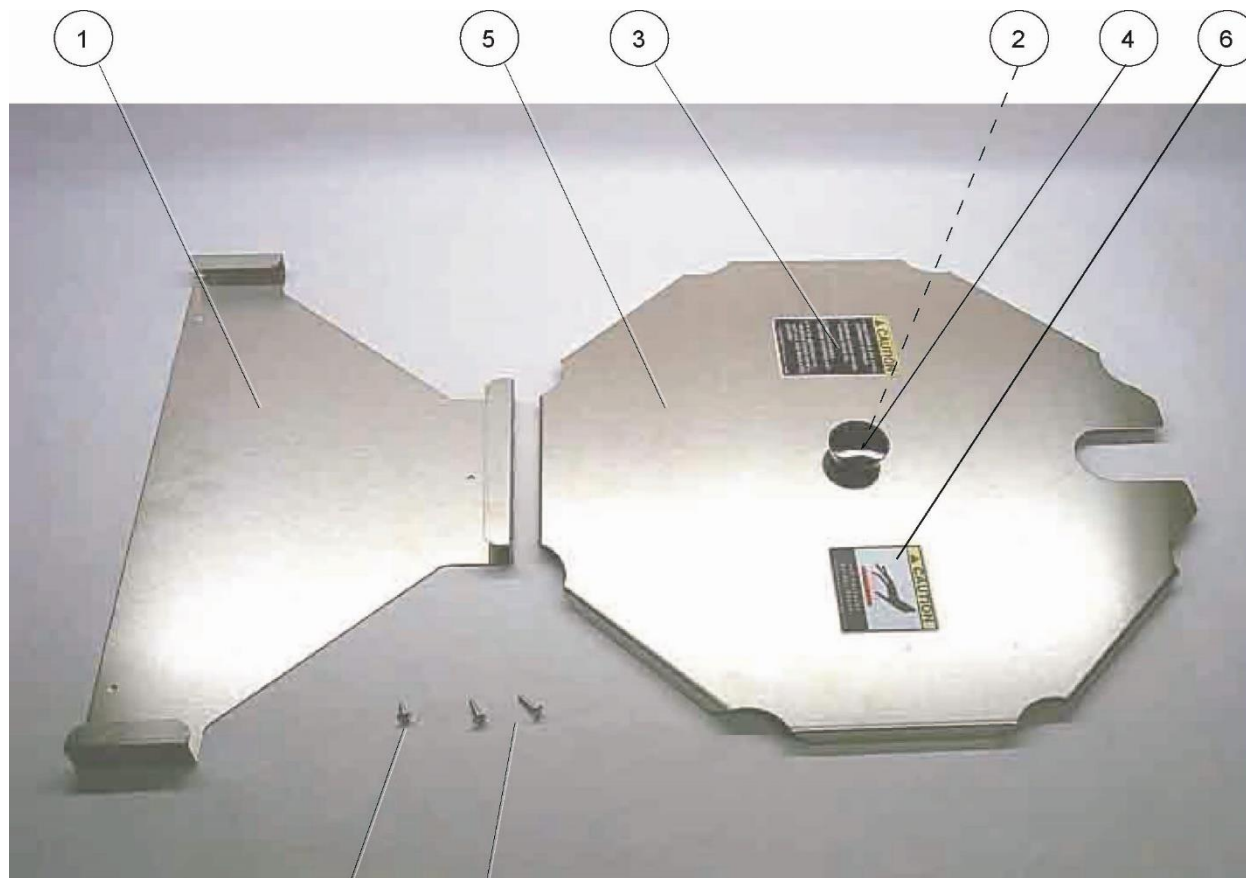

Table 8. Storage Cover Assembly Parts

ITEM #	PART #	QTY	DESCRIPTION
1	<a href="#">FB16009303</a>	1	HANGER, FRY POT COVER BLF
2	<a href="#">SCR303</a>	1	SCREW, 10-32 X 1/2 PHIL TRUSS
3	<a href="#">N0358</a>	1	DECAL, BLF COVER CAUTION
4	<a href="#">H0217</a>	1	HANDLE, STORAGE COVER, BLF
5	<a href="#">FB16007003</a>	1	COVER, STORAGE BLF TOP
6	<a href="#">N0162</a>	1	DECAL, CAUTION HOT SURFACES
7	<a href="#">TP0037*</a>	20"	TAPE, 7/8 DBL SIDE 3M06381 WHITE

\* Not Shown

**Components**

Description	Component #	Figure #	Item #
BASKET LIFT ARM WELD, LINEAR ACTUATOR	<a href="#">WB16015800</a>	Figure 9	1
CASTER, W/TOP PLATE 5"	<a href="#">C0406</a>	Figure 9	2
CAPACITOR, 7.5 MFD 370 VAC	<a href="#">CP0102</a>	Figure 9	3
FILTER BAG CLIP FKM-F	<a href="#">ST0015</a>	Figure 9	4
HINGE, SLIP WING RH	<a href="#">H0051</a>	Figure 9	5
HINGE, SLIP WING LH	<a href="#">H0052</a>	Figure 9	6
SWITCH 1A 250VAC SPDT	<a href="#">S0353</a>	Figure 9	7
SLIDE, UHMW U-SHAPE .5 X 1/8ID	<a href="#">S0106</a>	Figure 9	8
MOTOR, BALL DRIVE ACTUATOR	<a href="#">M0084</a>	Figure 9	9
COLLAR/LIFT ADJ WELD BLF	<a href="#">WA16015600</a>	Figure 9	10
SIDE CABINET, L&R FKM/DNF	<a href="#">FKMA399</a>	Figure 9	11
CALROD, 208V 5675W CALROD, 240V 5675W CALROD, 480V 5675W	<a href="#">C0030</a> <a href="#">C0031</a> <a href="#">C0132</a>	<b>Error!</b> <b>Reference</b> <b>source</b> <b>not</b> <b>found.</b>	12
WASHER, PTFE-FRYER CALROD	<a href="#">FT0059</a>	<b>Error!</b> <b>Reference</b> <b>source</b> <b>not</b> <b>found.</b>	13
BRACKET, CALROD FKMA258	<a href="#">LZ0006</a>	<b>Error!</b> <b>Reference</b> <b>source</b> <b>not</b> <b>found.</b>	14
BRACKET BACK PLATE FKMA259	<a href="#">LZ0007</a>	<b>Error!</b> <b>Reference</b> <b>source</b> <b>not</b> <b>found.</b>	15
PROBE, TEMPERATURE, 100 OHM RTD	<a href="#">T0184</a>	Figure 9	16
THERMOCOUPLE FITTING W/FERRULE & NUT	<a href="#">FT0287</a>	Figure 9	17
BUSHING, REDUCING 3/8" x 1/8"	<a href="#">FT0286</a>	Figure 9	18

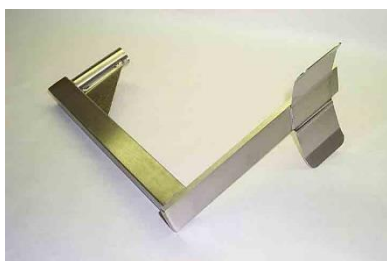
**Figure 9. Components**

1



2



3



4

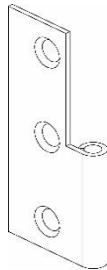

5

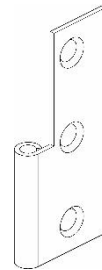

6



7



8



9



10

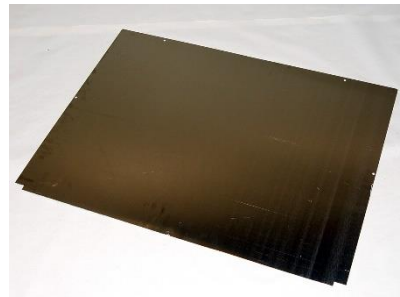

11



12

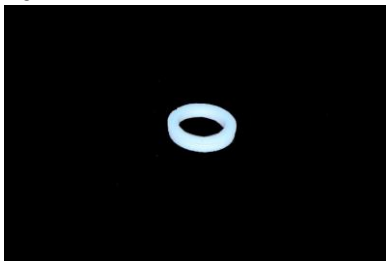

13



14



15



16



17



18

**Accessories**

Description	Accessory #	Figure #	Item #
BASKET, BLF	B0112	Figure 10	1
BASKET, BLF (GRANDE)	B0121	Figure 10	2
BRUSH, DRAIN (LONG WHITE)	B0075	Figure 10	3
BRUSH, L TIPPED 40152	B0063	Figure 10	4
BRUSH, POT SCRUBBER, WHITE	B0049	Figure 10	5
BRUSH, POT SCRUBBER, HIGH TEMP., WHITE	B1102	Figure 10	5
CLEANER, FRYER, OSG BOIL OUT COMPOUND	LC0006	Figure 10	6
FILTER HOSE, FEMALE SOCKET	SB2332	Figure 10	7
FILTER VAT DOLLY BLF-F	SB7650	Figure 10	8
GLOVE, NEOPRENE	G0089	Figure 10	9
FILTER, FKM-F 13.5 X 20.5	FI0007	Figure 10	10
RESTRAINT	FT0279	Figure 10	11
POT STIR STICK FOR 75# BLF	P0149	Figure 10	12

Figure 10. Accessories



# Wiring Diagrams

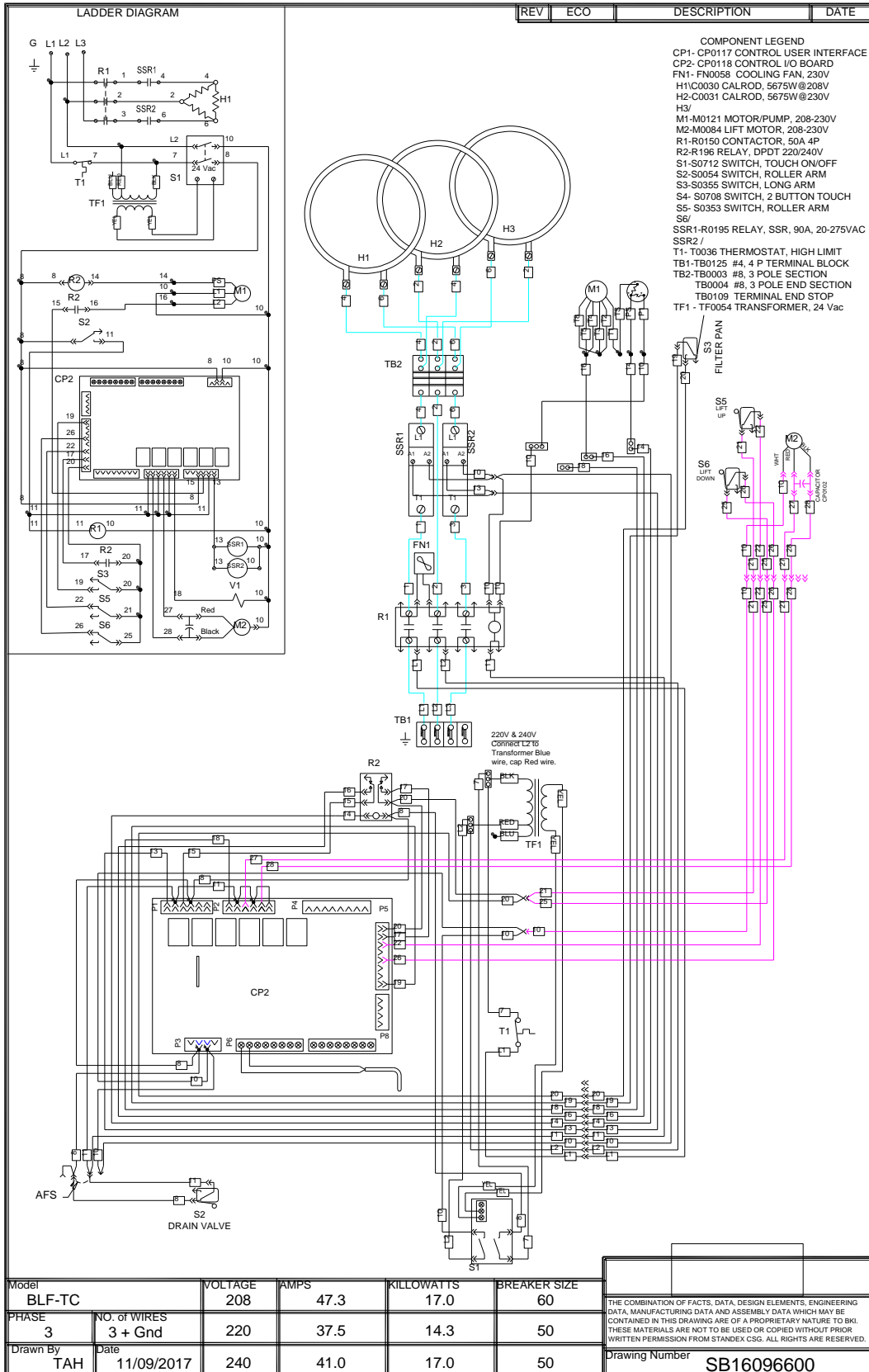

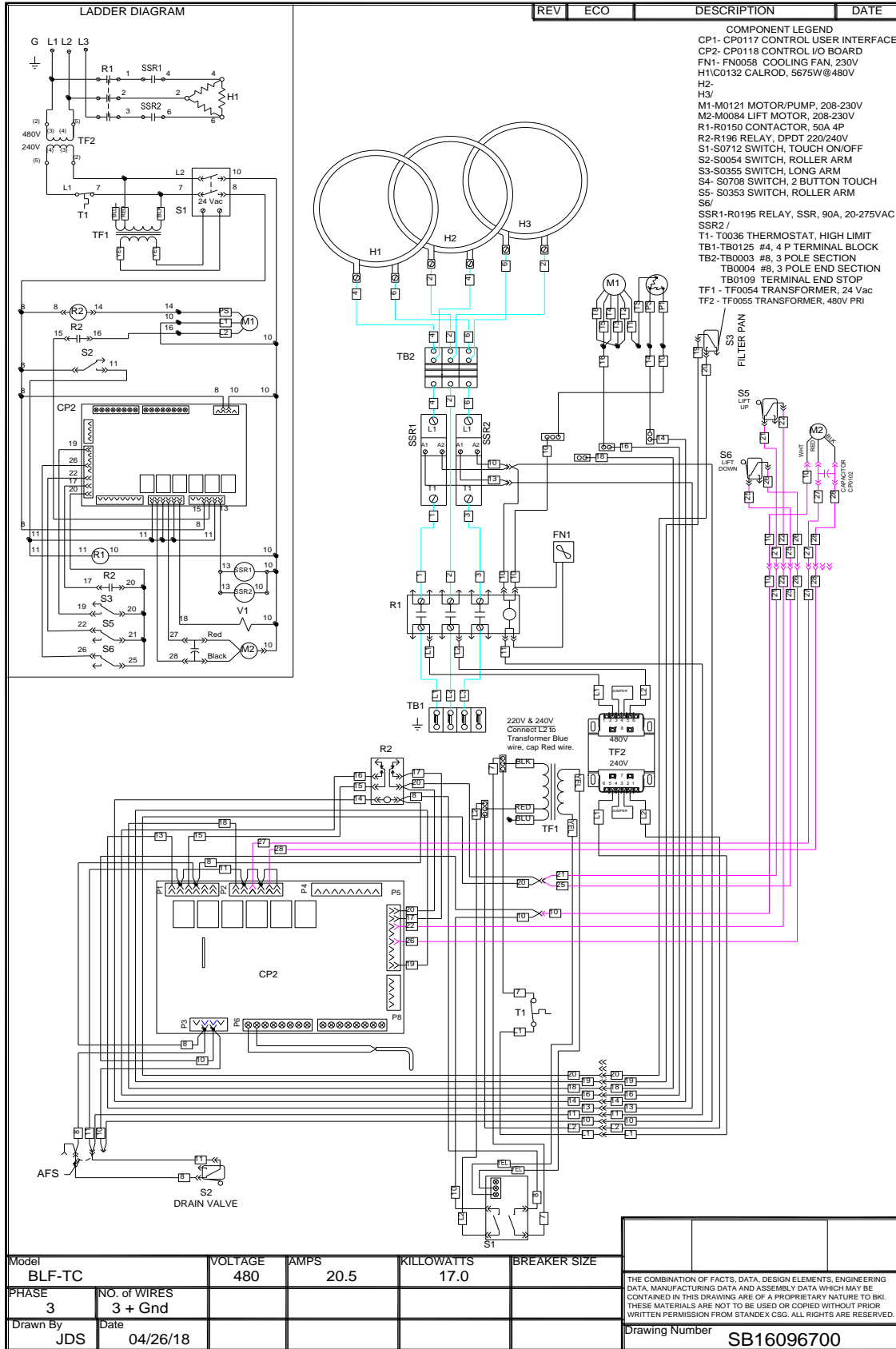

---

**Notes**



2812 Grandview Dr., Simpsonville, S.C. 29680, USA  
<http://www.bkideas.com>

Made and printed in the U.S.A