

Automatic Lift Fryer

MODELS BLF-F, & BLF-FC

Service Manual

Serial Numbers 137733 and higher



BKI LIMITED WARRANTY

2812 Grandview Dr. • Simpsonville, SC 29680 • USA
(864) 963-3471 • Toll Free: (800) 927-6887 • Fax: (864) 963-5316

WHAT IS COVERED

This warranty covers defects in material and workmanship under normal use, and applies only to the original purchaser providing that:

- ☒ The equipment has not been accidentally or intentionally damaged, altered or misused;
- ☒ The equipment is properly installed, adjusted, operated and maintained in accordance with national and local codes, and in accordance with the installation and operating instructions provided with this product.
- ☒ The serial number rating plate affixed to the equipment has not been defaced or removed.

WHO IS COVERED

This warranty is extended to the original purchaser and applies only to equipment purchased for use in the U.S.A.

COVERAGE PERIOD

- ☒ Warranty claims must be received in writing by BKI within one (1) year from date of installation or within one (1) year and three (3) months from date of shipment from the factory, whichever comes first.
- ☒ COB Models: One (1) Year limited parts and labor.
- ☒ COM Models: Two (2) Year limited parts and labor. COM convection ovens also have a two (2) year door warranty.
- ☒ CO1 Models: Two (2) Year limited parts and labor. Five (5) Year limited door warranty.
- ☒ BevLes Products: Two (2) Year limited parts and labor.
- ☒ Warranty period begins the date of dealer invoice to customer or ninety (90) days after shipment date from BKI, whichever comes first.

WARRANTY COVERAGE

This warranty covers on-site labor, parts and reasonable travel time and travel expenses of the authorized service representative up to (100) miles round trip and (2) hours travel time and performed during regular, weekday business hours.

EXCEPTIONS

Any exceptions must be pre-approved in advance and in writing by BKI. The extended door warranty on convection ovens years 3 through 5 is a parts only warranty and does not include labor, travel, mileage or any other charges.

EXCLUSIONS

- ☒ Negligence or acts of God,
- ☒ Thermostat calibrations after (30) days from equipment installation date,
- ☒ Air and gas adjustments,
- ☒ Light bulbs,
- ☒ Glass doors and door adjustments,
- ☒ Fuses,
- ☒ Adjustments to burner flames and cleaning of pilot burners,
- ☒ Tightening of screws or fasteners,
- ☒ Failures caused by erratic voltages or gas suppliers,
- ☒ Unauthorized repair by anyone other than a BKI Factory Authorized Service Center,
- ☒ Damage in shipment,
- ☒ Alteration, misuse or improper installation,
- ☒ Thermostats and safety valves with broken capillary tubes,
- ☒ Freight - other than normal UPS charges,
- ☒ Ordinary wear and tear,
- ☒ Failure to follow installation and/or operating instructions,
- ☒ Events beyond control of the company.

INSTALLATION

Leveling, as well as proper installation and check out of all new equipment - per appropriate installation and use materials - is the responsibility of the dealer or installer, not the manufacturer.

REPLACEMENT PARTS

BKI genuine Factory OEM parts receive a (90) day materials warranty effective from the date of installation by a BKI Factory Authorized Service Center.

Warranty is in lieu of all other warranties, expressed or implied, and all other obligations or liabilities on the manufacturer's part. BKI shall in no event be liable for any special, indirect or consequential damages, or in any event for damages in excess of the purchase price of the unit. The repair or replacement of proven defective parts shall constitute a fulfillment of all obligations under the terms of this warranty.

Table of Contents

Table of Contents	1
Introduction	2
Safety Precautions	2
Safety Signs and Messages	2
Specific Precautions	3
Equipotential ground plane.....	3
Full Disconnection	3
Safe Work Practices	4
Safety Labels	8
Installation	9
Operation	10
Controls and Indicators	10
Care of the Shortening	13
BLF-F Operation	13
Start-Up.....	13
Cooking.....	14
BLF-FC Operation	16
System Programming	16
Product Programming.....	18
Start-Up.....	21
Cooking.....	21
Maintenance	23
Replacement Parts	24
Assemblies.....	24
Accessories	36
Components.....	38
Wiring Diagrams	40
Notes	51

Introduction

The BLF Fryer is compact, attractive and functional in design. It is constructed of a stainless steel fryer pot for cleaning ease. Exclusive BKI patented features and safety devices offer flexibility, efficiency and reliability plus **PERFECTION IN FRYING!**

The BKI name and trademark on this unit assures you of the finest in design and engineering -- that it has been built with care and dedication -- using the best materials available. Attention to the operating instructions regarding proper installation, operation, and maintenance will result in long lasting dependability to insure the highest profitable return on your investment.

NOTICE

PLEASE READ THIS ENTIRE MANUAL BEFORE OPERATING THE UNIT. If you have any questions, please contact your BKI Distributor. If they are unable to answer your questions, contact the BKI Technical Service Department, toll free: 1-800-927-6887. Outside the U.S., call 1-864-963-3471.

Safety Precautions

Always follow recommended safety precautions listed in this manual. Below is the safety alert symbol. When you see this symbol on your equipment, be alert to the potential for personal injury or property damage.



Safety Signs and Messages

The following Safety signs and messages are placed in this manual to provide instructions and identify specific areas where potential hazards exist and special precautions should be taken. Know and understand the meaning of these instructions, signs, and messages. Damage to the equipment, death or serious injury to you or other persons may result if these messages are not followed.

⚠ DANGER

This message indicates an imminently hazardous situation which, if not avoided, will result in death or serious injury.

⚠ WARNING

This message indicates a potentially hazardous situation, which, if not avoided, could result in death or serious injury.

⚠ CAUTION

This message indicates a potentially hazardous situation, which, if not avoided, may result in minor or moderate injury. It may also be used to alert against unsafe practices.

NOTICE

This message is used when special information, instructions or identification are required relating to procedures, equipment, tools, capacities and other special data.

Specific Precautions

⚠ WARNING

Risk of fire exists if the oil level drops below 5mm of the maximum oil level.

⚠ WARNING

Use of oil/shortening older than the manufacturers recommendations for life of the oil is prone to surge boiling and flash fires. Follow the oil manufacturers guidelines for the life cycle of oil/shortening.

⚠ WARNING

Do not open the drain valve or the fill valve while the fryer is under pressure. Serious burns may result.

⚠ CAUTION

Follow operator instructions regarding effects of surge boiling of over-wet foods and proper load size.

⚠ CAUTION

This unit may incorporate components that contain Mercury. The use of Mercury relays is an industry standard.

⚠ CAUTION

Equipotential ground plane

When a high current flows through a conductor, differences in potential appear between the conductor and nearby metallic surfaces near the appliance. As a result, sparks may be produced between the appliance and surrounding metal surfaces. These sparks could cause serious injury, damage, or fire.

BKI provides an Equipotential ground terminal for the connection of a bonding conductor after the installation of the appliance per IEC60417-1. This terminal is located on the inside of the Power Entry Supply box near the Earth connection and is marked with this symbol.



NOTICE

Full Disconnection

In accordance with Local and/or National wiring codes, the installer must provide a means of full disconnection under over voltage Category III conditions. An IEC approved cord and plug combination will meet this requirement.

Units not provided with a cord and plug do not meet this requirement. In accordance with Local and/or National wiring codes, the installer must provide the means of full disconnection.

NOTICE

The fryer is designed to hold a maximum of 75 lb (34 kg) of oil/shortening.

Safe Work Practices

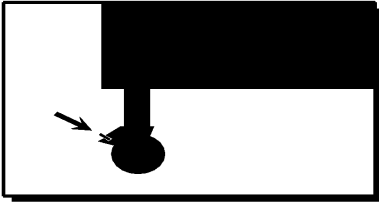

Keep The Casters Locked

To avoid spilling shortening, keep the casters locked. If any shortening spills near your fryer, clean it up immediately.



Noncombustible Floors Only

Make sure your floor is noncombustible. Do not operate your fryer on floors that are wood, carpeted or have rubber mats.

- Placing your fryer on a combustible floor could cause a fire. Serious injury could result.
- Examples of noncombustible floors where you can safely place your fryer are concrete, tile, and ceramic.



Keep The Area Around Your Fryer Uncluttered

Make sure to keep the area around your fryer clear of any obstacles.

Serious injury can occur if you trip or fall near the fryer. You could be burned by hot shortening that splashes out of the fryer or by falling against the hot metal of the fryer.



Keep The Floor Around Your Fryer Clean Of Shortening

Make sure to keep the floor around your fryer clean of shortening and other liquids.

Serious injury can occur if you slip near your fryer. You could be burned by hot shortening that splashes out of the fryer or by falling against the hot metal of the fryer.

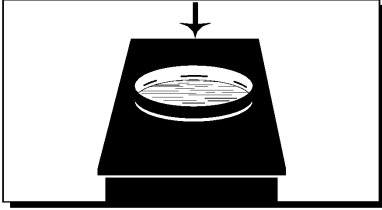

Do Not Overfill The Fryer With Shortening

Hot shortening and steam may escape and burn you if you put too much shortening in the fryer. Fill the fryer to approximately one inch below the fill marks that are inside the fryer pot. Heat the shortening. If needed, carefully add more shortening to bring the level to the fill marks.

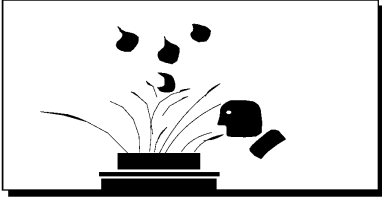

Do Not Let Any Water Get Into The Fryer

Always remove excess moisture from food before placing it into the fryer basket. Water will cause the hot shortening to spatter. You could be burned.



Do Not Overload The Basket With Food

Hot shortening and steam may escape and burn you if you place too much food in the basket.

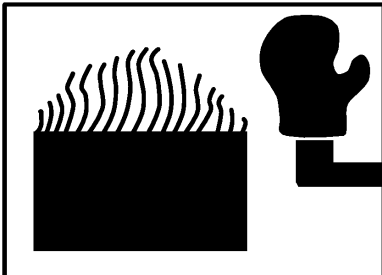

Wear Safe Clothing Appropriate To Your Job

Always wear your insulated mitts when handling the fryer basket or touch any hot metal surfaces. You received a pair of insulated mitts with your fryer. If you lose or damage your mitts, you can buy new ones at your local restaurant equipment supply store or from your local **BKI** Distributor.

Always wear non-skid shoes when working around the fryer or any other equipment that uses shortening. Never wear loose clothing such as neckties or scarves while operating your fryer. Keep loose hair tied back or in a hair net while operating your fryer.

Always wear appropriate personal protection equipment during the filtering process to guard against possible injury from hot oil.

Always wear appropriate personal protection equipment during the boil-out process to guard against possible injury from hot cleaning solution.

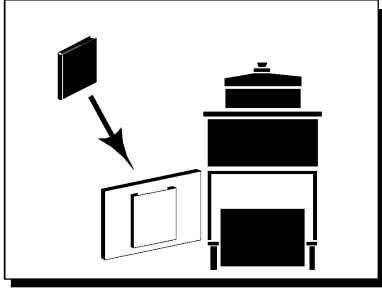

Keep this manual with the Equipment

This manual is an important part of your equipment. Always keep it near for easy access.

If you need to replace this manual, contact:

BKI

Technical Services Department
2812 Grandview Drive
Simpsonville, S.C. 29680
Or call toll free: 1-800-927-6887
Outside the U.S., call 864-963-3471



Protect Children

Keep children away from this equipment. Children may not understand that this equipment is dangerous for them and others.

NEVER allow children to play near or operate your equipment.

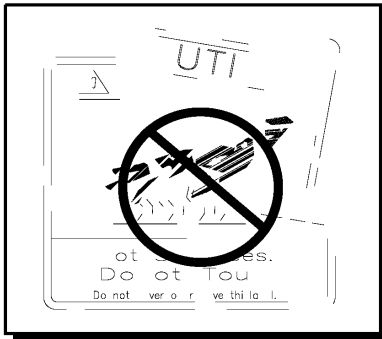

Keep Safety Labels Clean and in Good Condition

Do not remove or cover any safety labels on your equipment. Keep all safety labels clean and in good condition. Replace any damaged or missing safety labels. Refer to the Safety Labels section for illustration and location of safety labels on this unit.

If you need a new safety label, obtain the number of the specific label illustrated on page 8, then contact:

BKI

Technical Services Department
2812 Grandview Drive
Simpsonville, S.C. 29680
Or call toll free: 1-800-927-6887
Outside the U.S., call 864-963-3471

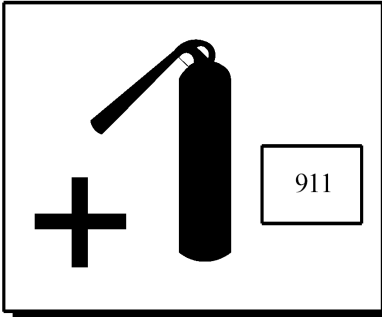

Be Prepared for Emergencies

Be prepared for fires, injuries, or other emergencies.

Keep a first aid kit and a fire extinguisher near the equipment. You must use a 40-pound Type BC fire extinguisher and keep it within 25 feet of your equipment.

Keep emergency numbers for doctors, ambulance services, hospitals, and the fire department near your telephone.

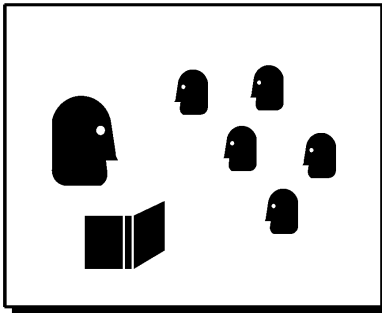

Know your responsibilities as an Employer

- Make certain your employees know how to operate the equipment.
- Make certain your employees are aware of the safety precautions on the equipment and in this manual.
- Make certain that you have thoroughly trained your employees about operating the equipment safely.
- Make certain the equipment is in proper working condition. If you make unauthorized modifications to the equipment, you will reduce the function and safety of the equipment.

Safety Labels

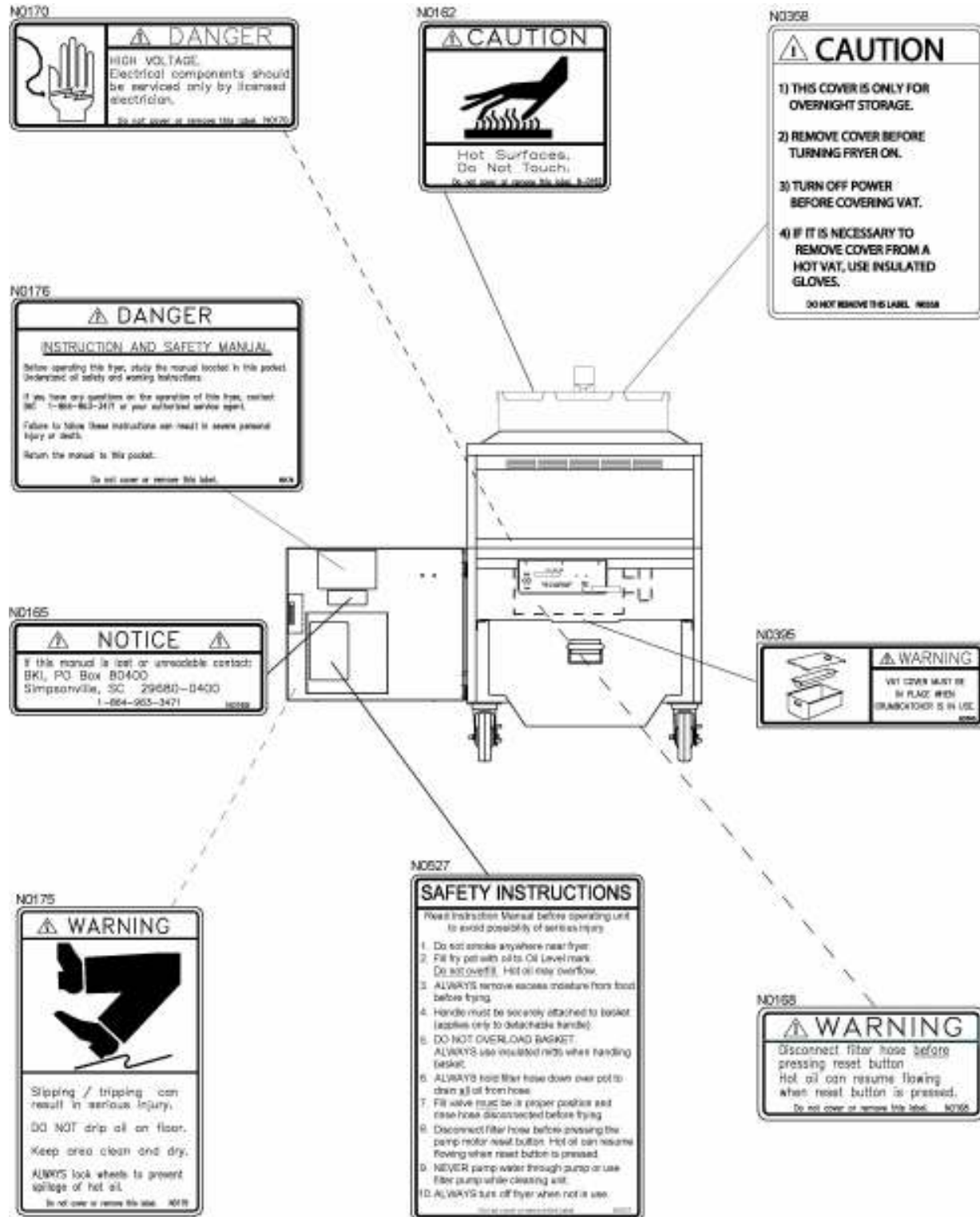

Installation

For installation information, refer to *Automatic Lift Fryer, MODELS BLF-F, & BLF-FC, Installation and Operation Manual LI0225*.

Operation

Controls and Indicators

Refer to the figure and table below for an explanation of the fryer's controls and indicators.

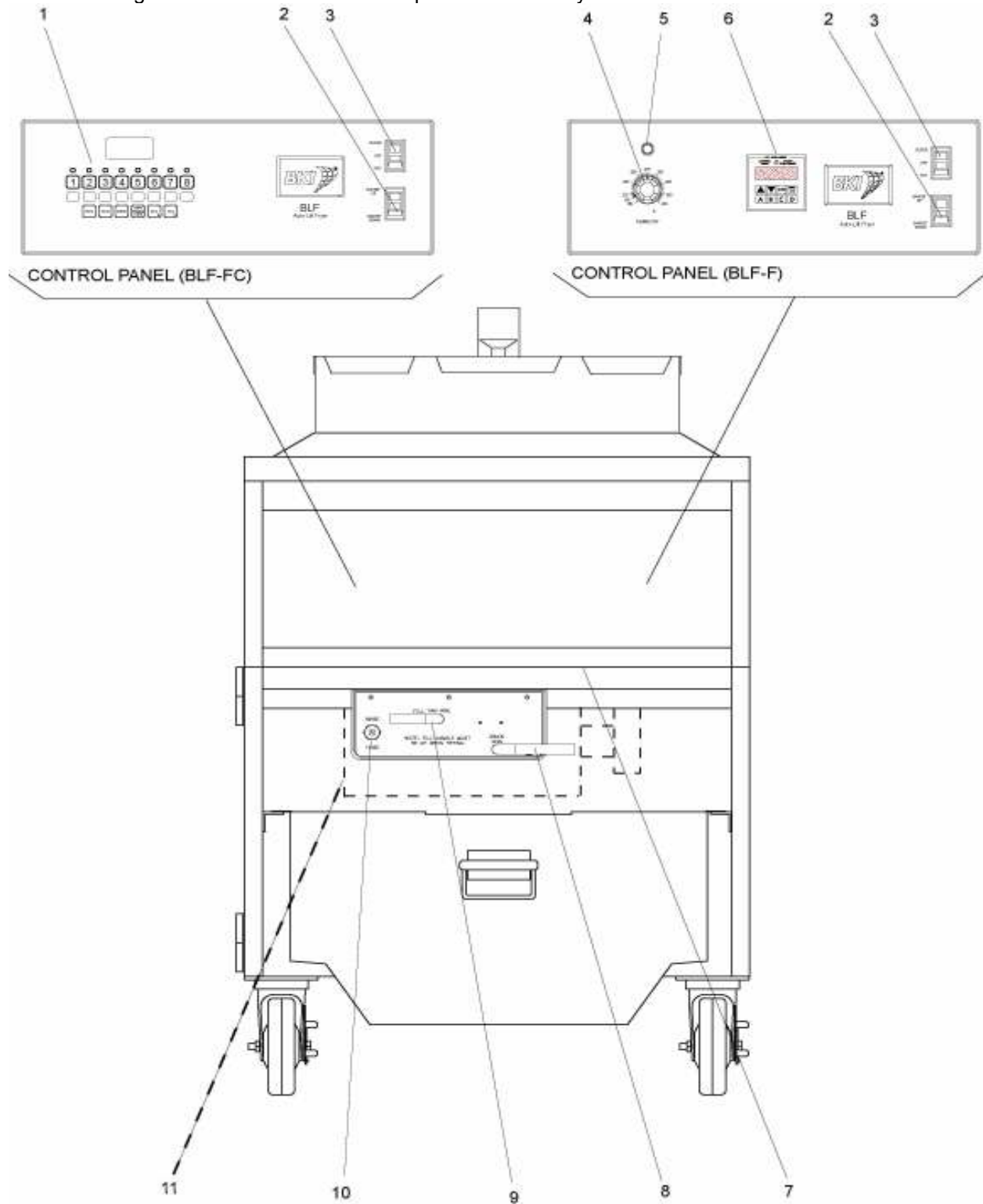

Item #	Description	Function
1	Computer	Used to program the cooking computer and activate the programs.
2	Momentary Switch	BASKET UP – Momentarily pushing the switch to this position causes the lift mechanism to rise. This is enabled only when the FILTER/OFF/FRY switch is in the FRY position. BASKET DOWN – Momentarily pushing the switch to this position causes the lift mechanism to lower. This is enabled only when the FILTER/OFF/FRY switch is in the FRY position.
3	Rocker Switch	FILTER – When placed in this position, power is applied to the motor and shorting is pumped into the pot directly or thru the fill hose. OFF – When placed in this position, power is removed from the pump motor, heating elements and lift mechanism. FRY – When placed in this position, power is supplied to the thermostat, heating elements and lift mechanism.
4	Thermostat Knob	Used to set the temperature of the shortening.
5	Thermostat Light	Illuminates to indicate that the set temperature of the shortening has been reached.
6	Digital Timer	The digital timer consists of an LED, display, beeper and 8 buttons described below:
	LED indicator	Prior to the start of a timing cycle the LED will be OFF. When running a timing cycle the LED will flash. At the end of a timing cycle the LED will turn ON steady. When idle the LED is off.
	TIME SELECT (2 arrow buttons)	Two arrow buttons on the front panel are used to set the time. Hold the UP ARROW button down to increase the time. The longer the button is held down, the faster the rate at which the time will increase. The DOWN ARROW button is used in the same manner as the UP ARROW button except it will cause the time to decrease. The time is increased or decreased in 30-second increments.
	START/STOP button	Starting the Timer - Pressing this button while the timer is not active will cause the timer to begin counting down the time on the display. Stopping the Timer - Pressing this button while the timer is active will stop the timer from counting down and display the remaining time. Time cannot be changed with the TIME SELECT buttons at this point. If this button is pressed again the timer will continue counting down from the point it was stopped. Resetting the Timer - Pressing and holding this button for longer than two (2) seconds will reset the timer and the display will return to the original starting time. At this point, time can be changed using the TIME SELECT buttons or the preset buttons. Canceling The STIR OIL Function - Pressing this button cancels the STIR OIL function while it is active.

Item #	Description	Function
6	ALARM button	This button allows the user to set an elapsed time at which the internal alarm will sound during a cycle. The time is set by pressing and holding the ALARM button while using the UP and DOWN arrows to change the time. The controller will limit the alarm time to be less than the currently programmed interval cycle time. The default alarm time is 0:00 which disables it. The ALARM time is saved on power down in the same manner as the last interval time. When a time cycle is running and the alarm time has elapsed the internal alarm will sound for 10 seconds. For example, a cycle time 10:00 and alarm time of 2:00 would cause the alarm to sound for 10 seconds once the controller has counted down from 10:00 to 8:00. This button is used to cancel the STIR OIL alarm. This button is also used to reconfigure the STIR OIL Function.
	A, B, C, D preset buttons	These buttons are used to save and recall preset cycle and alarm times, saving operator time and minimizing error when changing interval cycle times and alarm times. To save the current interval and alarm times into one of the preset locations, press and hold the A, B, C, or D preset button for 2 seconds and the controller will double chirp to indicate the times have been saved. To recall any preset time, press and quickly release the appropriate button and the time values are loaded and displayed. These buttons are also used to reconfigure the STIR OIL function.
	Beeper	A beeper sounds when the timer counts down to 0. Pressing the START/STOP button stops the beeper and resets the timer causing the display to return to the original starting time. At this point, time can be changed using the TIME SELECT buttons or the preset buttons. The beeper will also sound for 10 seconds if the alarm time has elapsed during a timing cycle. When the STIR OIL function begins the beeper will sound until the ALARM or START/STOP button is pressed.
	Display	Used to display the time. It also displays the words "STIR" then "OIL" in .5 second intervals until the ALARM or START/STOP button is pressed.
7	High Limit Reset Switch	Located under the control panel. If the heating elements inside the pot reach an unsafe temperature, power is automatically removed from the control panel, lift mechanism and elements. Pressing this switch returns power to the control panel, lift mechanism and elements.
8	Drain Lever	DRAIN OPEN – When placed in this position, the drain valve opens and shortening in the pot drains into the vat. Also, power is removed from the control panel, lift mechanism and elements. DRAIN CLOSED – When placed in this position, the drain valve is closed to prevent shortening from draining into the pot.
9	Fill Lever	FILL THRU POT – When placed in this position, shortening can be pumped automatically from the vat to the pot if the rocker switch is in the FILTER position. FILL THRU HOSE – When placed in this position, shortening can be pumped from the vat to the pot via a connected hose if the rocker switch is in the FILTER position.
10	Rinse Hose Connector	Used to connect the Rinse hose for cleaning and refilling the pot.
11	Pump Motor Reset Switch	If the motor overheats while filtering, it will automatically shut off. Wait 15 minutes to allow motor to cool before pressing this switch.

Care of the Shortening

To extend the life of your shortening, for the best possible flavor in your products, and for economy and efficiency of operation, we urge you to follow these recommendations:

1. Use only high-quality frying shortening without additives, of low moisture content and with a high smoke point.
2. Press excess moisture from products before breading. The more moisture released in the shortening, the quicker it will break down.
3. Filter at least once a day or once every three loads during frequent cooking.
4. Clean any residue or crust formations from the sides and bottom of the pot each time you filter the shortening.
5. Add fresh shortening as needed to maintain the proper shortening level **TO THE FILL MARK ON THE POT WALL**.
6. **DO NOT HOLD SHORTENING AT HIGH TEMPERATURE** when the fryer is not in use. If you expect an elapsed time of one hour or more between cooking, press the "0" button on the BLF-FC model. On the BLF-F, set the thermostat to 150° F.
7. Shortening changes are determined by the quantity and type of food prepared. Excessive boiling and foaming are definite signs of shortening breakdown.
8. After you have finished frying for the day, filter the shortening and replace the filter pad. Also, thoroughly clean the pot of sediment and crumbs and empty the condensate pan.

BLF-F Operation

Start-Up

1. Make sure the main drain valve is closed.
2. Fill pot with shortening to about one inch below the fill mark.

⚠ WARNING

Risk of fire exists if the oil level drops below the minimum oil level. The level of oil within the pot must not fall below 5mm of the maximum oil level.

⚠ WARNING

Use of oil/shortening older than the manufacturers recommendations for life of the oil is prone to surge boiling and flash fires. Follow the oil manufacturers guidelines for lifecycle of oil/shortening.

⚠ CAUTION

Overfilling the fryer pot with shortening could lead to serious injury. Ensure that the fryer pot is filled with shortening only to the fill mark when shortening is hot. Do not use any shortening other than what is specified in this manual and do not overfill the fryer pot.

⚠ CAUTION

The fryer has a maximum temperature setting of 375° F/190° C (for BLF and BLF-F) or 390° F/200° C (for BLF-FC). Do not use oil/shortening with a flashpoint less than 554° F (290° C)

NOTICE

Use only high-quality shortening that has low moisture content, a high smoke point and no additives.

3. The digital timer has a STIR OIL function that operates in one of four reconfigurable modes. If the timer needs to be reconfigured, follow step a. If the timer does not need to be reconfigured, follow step b.
 - a. Press and hold the ALARM button and at the same time place the **FILTER/OFF/FRY** switch in the **FRY** position. The display will show the word "STIR" until the ALARM button is released. When the button is released the display will show the current configuration mode. To change this mode select the timer key that represents the mode you want. Refer to the table below:

KEY	DISPLAY	MODE DESCRIPTION
A	-AL-	New or unchanged timer. Alarm sounds at the end of the internal 6 minute countdown.
B	-OFF	Defeats the STIR OIL function. Timer operates as if it had no STIR OIL function.
C	PrES	STIR OIL function for all Pressure Fryers.
D	LiFT	STIR OIL function for all Autolift Fryers.

The display will now show the selected mode. Proceed to step c.

- b. Once the fryer is filled with shortening, place the **FILTER/OFF/FRY** switch in the **FRY** position.
 - c. Unless the STIR OIL function is operating in the –OFF mode, the digital timer activates a STIR OIL function and begins an internal six minute countdown (not displayed). At the end of the internal countdown, the display shows the words "STIR" then "OIL" in .5 second intervals and the alarm sounds. Depress the **ALARM** button and stir the shortening freely while it is heating.

IMPORTANT! Before the first cooking operation each day, stir the shortening freely while it is heating to provide a balanced shortening temperature for excellent results with the first cooking. Failure to do this can result in a crusty skin on the product surface with an undercooked product internally. In addition, in some cases, failure to stir the shortening while it is initially heating may cause the HI-LIMIT safety device to disable the power due to a false overtemperature condition.
4. Set the thermostat to the desired cook temperature. The temperature light will go on. When the temperature is reached, the light will go off. The light will continue to cycle on and off as the fryer maintains the set temperature.
5. Raise the basket to the top position by depressing the basket switch to the **BASKET UP** position.
6. Press and hold the **TIME SELECT** arrow buttons on the digital timer until the desired cook time is displayed or recall a preset time by quickly pressing the appropriate preset button.
7. The shortening will heat and begin to reach the fill mark inside the pot. Add more shortening as required to reach the fill mark.

Cooking

1. Ensure that the Start-Up procedures have been performed.
2. When frying chicken, lower the basket into the shortening by depressing the basket switch to the **BASKET DOWN** position.

⚠ WARNING

Hot shortening may splash out of the pot causing severe injury when dropping chicken into pot. Carefully drop pieces of chicken into pot to prevent shortening splashes.

3. Carefully drop the chicken in the shortening one piece at a time starting with thighs and drumsticks. The fryer is designed to accommodate 48-50 pieces of chicken.
4. Activate the timer by pressing the **START/STOP** button on the digital timer. The timer will begin the count down.
5. At the end of the frying cycle, the digital timer beeper will sound and the basket will automatically rise to its top position. Press the **START/STOP** button on the digital timer.
6. Allow the basket to drain.

⚠ DANGER

Failure to use the insulated mitts will result in injury. Always use the insulated mitts when handling the hot fry basket.

7. Remove basket from the lift and empty carefully.
8. Return the basket to the lift.
9. Remember to filter the shortening at least every third frying cycle load. Refer to the procedure in this manual. Also filter the shortening and clean the fryer at the end of each day. If you do not plan to use the fryer for an hour or more, turn the thermostat down to 150°.
10. When you have finished frying for the day, turn the **FILTER/OFF/FRY** switch to the **OFF** position.

BLF-FC Operation

System Programming

Use the following figure and table to set options that apply to each product programs.

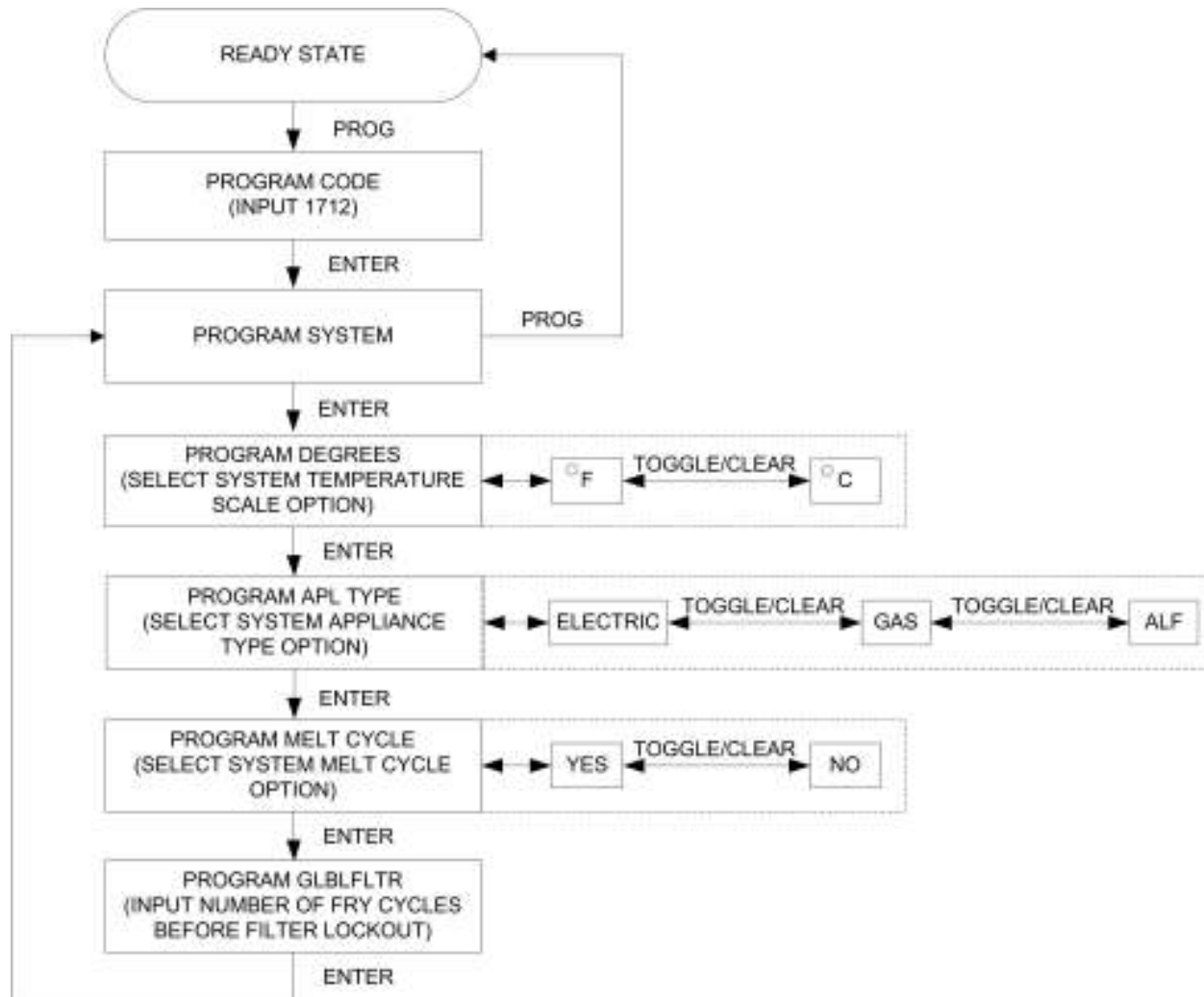

Figure 1. System Programming Sequence

Table 1. System Programming Procedure

STEP	ACTION	DISPLAY	COMMENTS
1	Press the FILTER/OFF/FRY switch to FRY .	LOW	
2	Press PROG on the keypad.	PROGRAM CODE	
3	Input 1712 and ENTER.	PROGRAM SYSTEM	
4	Press ENTER.	PROGRAM DEGREES °F	This command allows you to choose the temperature scale option you want to use. The display will show either show °F or °C.
5	Press TOGGLE/CLEAR until the desired option is displayed.	PROGRAM DEGREES X	X refers to the temperature scale you have chosen.
6	Press ENTER.	PROGRAM APL TYPE ELECTRIC	This command allows you to choose the appliance type you are using. The display may show ELECTRIC, GAS OR ALF.
7	Press TOGGLE/CLEAR until the desired option is displayed.	PROGRAM APL TYPE X	X refers to the appliance type you have chosen.
8	Press ENTER.	PROGRAM MELTCYCL YES	This command allows you to set the melt cycle option. This is normally set to yes if you are using solid shortening. The display will show either YES or NO.
9	Press TOGGLE/CLEAR until the desired option is displayed.	PROGRAM MELTCYCL X	X refers to the melt cycle option chosen.
10	Press ENTER.	PROGRAM GLBLFLTR 0	This command allows you to specify the total number of fry cycles to complete among all product programs before a message is displayed reminding you to filter the shortening (filter lockout).
11	Press TOGGLE/CLEAR and input the number of fry cycles you want to complete among all product programs before enabling filter lockout.	PROGRAM GLBLFLTR X	X refers to the number of program cycles you want to complete among all product programs before filtering the shortening.
12	Press ENTER.	PROGRAM SYSTEM	
13	Press PROG to exit the programming mode.	LOW	

Product Programming

Use the following figure and table to set a maximum of eight product programs. The product programs must be set before cooking can begin.

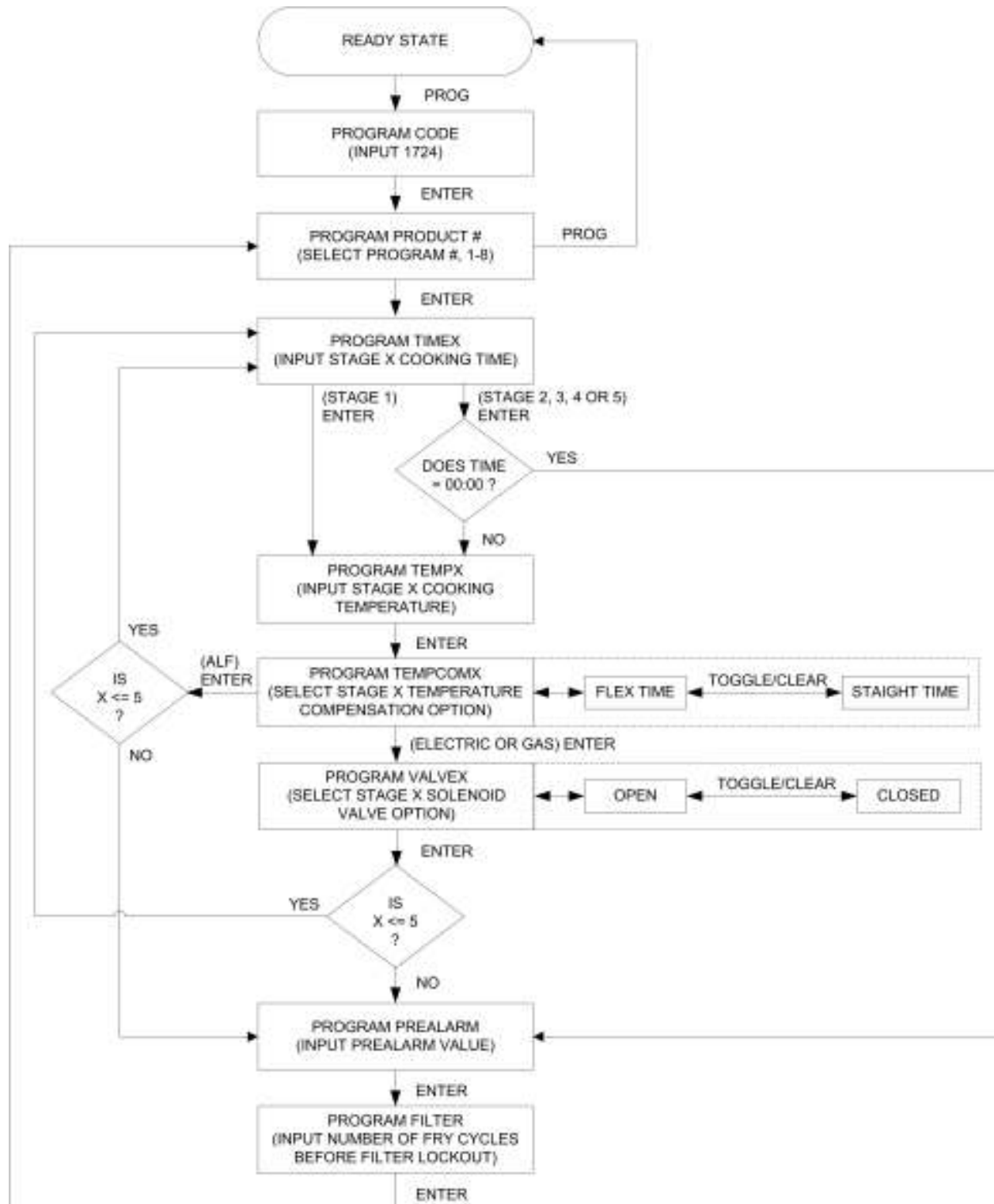

Figure 2. Product Programming Sequence

Table 2. Product Programming Procedure

STEP	ACTION	DISPLAY	COMMENTS
1	Press the FILTER/OFF/FRY switch to FRY .	LOW	
2	Press PROG on the keypad.	PROGRAM CODE	
3	Input 1724 and press ENTER.	PROGRAM PRODUCT #	
4	Select the program product number (1-8).	PROGRAM PRODUCT X	X refers to the program number you selected.
5	Press ENTER.	PROGRAM TIME1 00:00	This command allows you to specify the cooking time for this stage. The time displayed may be a previously programmed value.
6	Press TOGGLE/CLEAR and input the number of minutes you want to cook.	PROGRAM TIME1 XX:XX	XX:XX refers to the number of minutes you input.
7	Press ENTER.	PROGRAM TEMP1 000 °F	This command allows you to specify the cooking temperature for this stage. The temperature displayed may be a previously programmed temperature. The temperature scale may also display °C depending on the system option that is set.
8	Press TOGGLE/CLEAR and input the cooking temperature for product to be cooked.	PROGRAM TEMP1 XXX °F	XXX refers to the cooking temperature you input.
9	Press ENTER.	PROGRAM TEMPCOM1 FLEX TIME	This command enables you to select whether or not time is allowed for the fryer to recover from temperature loss while cooking during this stage. The FLEX TIME option will allow the fryer to recover from temperature loss.
10	Press TOGGLE/CLEAR until the desired option is displayed.	PROGRAM TEMPCOM1 X	X refers to the temperature compensation option selected.
11	Press ENTER.	PROGRAM VALVE1 CLOSED	This command allows you to specify whether the solenoid valve will be open or closed during this stage.

STEP	ACTION	DISPLAY	COMMENTS
12	Press TOGGLE/CLEAR until the desired option is displayed.	PROGRAM VALVE1 X	X refers to the solenoid valve option selected. OPEN is used for Models ALF and BLF Automatic Lift fryers. If your program requires the solenoid valve to be closed while cooking, choose the CLOSED option.
13	Repeat steps 5-12 when programming stages 2, 3, 4 and 5 for Electric and Gas appliance types. Repeat steps 5-10 when programming stages 2, 3, 4 and 5 for an ALF appliance type.		The time and temperature of each stage has to be less than the preceding stage.
14	Press ENTER.	PROGRAM PREALARM 00:00	This command allows you to specify the number of minutes before the end of the cooking time (for each stage) until the alarm sound The prealarm value displayed may be a previously programmed value.
15	Press TOGGLE/CLEAR and input the prealarm minutes.	PROGRAM PREALARM XX:XX	XX:XX refers to the prealarm minutes you input.
16	Press ENTER.	PROGRAM FILTER 0	This command allows you to specify the number of fry cycles you want to complete for this program before a message is displayed reminding you to filter the shortening (filter lockout). The filter value displayed may be a previously programmed value.
17	Press TOGGLE/CLEAR and input the number of fry cycles you want to complete before enabling filter lockout.	PROGRAM FILTER X	X refers to the number of program cycles you want to complete before filtering the shortening.
18	Press ENTER.	PROGRAM PRODUCT #	
19	If you wish to input more programs, proceed by pressing the next program number and follow steps 5 through 18 or press PROG to exit the programming mode.		

Start-Up

1. Make sure the main drain valve is closed.
2. Fill pot with shortening to about one inch below the mark.

WARNING

Risk of fire exists if the oil level drops below the minimum oil level. The level of oil within the pot must not fall below 5mm of the maximum oil level.

WARNING

Use of oil/shortening older than the manufacturers recommendations for life of the oil is prone to surge boiling and flash fires. Follow the oil manufacturers guidelines for lifecycle of oil/shortening.

CAUTION

Overfilling the fryer pot with shortening could lead to serious injury. Ensure that the fryer pot is filled with shortening only to the fill mark when shortening is hot. Do not use any shortening other than what is specified in this manual and do not overfill the fryer pot.

CAUTION

The fryer has a maximum temperature setting of 375° F/190° C (for ALF and ALF-F) or 390° F/200° C (for ALF-FC). Do not use oil/shortening with a flashpoint less than 554° F (290° C)

NOTICE

Use only high-quality shortening that has low moisture content, a high smoke point and no additives.

3. Place the **FILTER/OFF/FRY** switch to the **FRY** position. The question "Is the Fry Pot filled – If yes press ENTER" will appear on the computer display. The shortening will heat and begin to reach the fill mark inside the pot.
4. Add more shortening as required to reach the fill mark. Once the oil reaches the fill mark, press the **ENTER** button. The computer will display "STIR OIL" and automatically enter the STIR OIL mode. In this mode the computer will heat the oil to 255°F and hold that temperature.
5. Stir the oil freely while it is heating. Press the **0** button when finished stirring the oil.

IMPORTANT! Before the first cooking operation each day, stir the shortening freely while it is heating to provide a balanced shortening temperature for excellent results with the first cooking. Failure to do this can result in a crusty skin on the product surface with an undercooked product internally. In addition, in some cases, failure to stir the shortening while it is initially heating may cause the HI-LIMIT safety device to disable the power due to a false overtemperature condition.

Cooking

1. Ensure that the Start-Up procedures have been performed.
2. Press the desired program number on the keypad. The computer will still display "**LOW**". The fryer will begin to heat to the temperature that has been factory preset. When "**READY**" appears on the display, the fryer is up to the desired temperature.
3. When frying chicken, lower the basket into the shortening by depressing the basket switch to the **BASKET DOWN** position.

WARNING

Hot shortening may splash out of the pot causing severe injury when dropping chicken into pot. Carefully drop pieces of chicken into pot to prevent shortening splashes.

4. Carefully drop the chicken in the shortening one piece at a time starting with thighs and drumsticks. The fryer is designed to accommodate 48-50 pieces of chicken.
5. Press the desired program number a second time. The red light above the program number will flash and the computer will display "**COOK**". This will start a countdown in minutes and seconds until the end of the cycle.
6. At the end of the cooking cycle, the computer will display "**DONE**" and signal with a series of audible "beeps". The basket will automatically rise out of the pot. Press the selected number once again to stop the cook cycle.
7. Allow the basket to drain.



Failure to use the insulated mitts will result in injury. Always use the insulated mitts when handling the hot fry basket.

8. Remove basket from the lift and empty carefully.
9. Return the basket to the lift.
10. Remember to filter the shortening at least every third frying cycle load. Refer to the procedure in this manual. Also filter the shortening and clean the fryer at the end of each day.
11. Press the **0** button. **Idle 255°F** will display. This will automatically hold the shortening at a cooler temperature.
12. To escape the idle mode, press the **0** button again and the fryer will heat to its original temperature.
13. When you have finished frying for the day, turn the **FILTER/OFF/FRY** switch to the **OFF** position.

Maintenance

For maintenance information, refer to *Automatic Lift Fryer, MODELS BLF-F, & BLF-FC, Installation and Operation Manual LI0225*.

Replacement Parts

Use the information in this section to identify replacement parts. To order replacement parts, call your local BKI sales and service representative. Before calling, please note the serial number, model number and voltage on the rating tag affixed to the unit.

Assemblies

Description	Assembly #	Figure #	Table #
DOOR ASSEMBLY	AB16006700	Figure 3	Table 3
DRAIN VALVE & PLUGS	SB1999S	Figure 4	Table 4
DRAIN/MOTOR/PIPING ASSEMBLY	N/A	Figure 5	Table 5
FRONT PANEL BLF-F EUROPE FRONT PANEL BLF-F DOMESTIC	AN16017700 AN16017300	Figure 6	Table 6
FRONT PANEL BLF-FC EUROPE FRONT PANEL BLF-FC DOMESTIC	AN16017800 AN16017400	Figure 7	Table 7
REAR PANEL BLF-F EUROPE REAR PANEL BLF-F DOMESTIC	AN16017500 AN16017100	Figure 8	Table 8
REAR PANEL BLF-FC EUROPE REAR PANEL BLF-FC DOMESTIC	AN16017600 AN16017200	Figure 9	Table 9
OIL VAT ASSEMBLY	AN16010200	Figure 10	Table 10
QUICK DISCONNECT ASSEMBLY	AN19103300 SB1997S	Figure 11	Table 11
TERM BLOCK ASSEMBLY ENGLAND	AN19102100	Figure 12	Table 12

Figure 3. Door Assembly

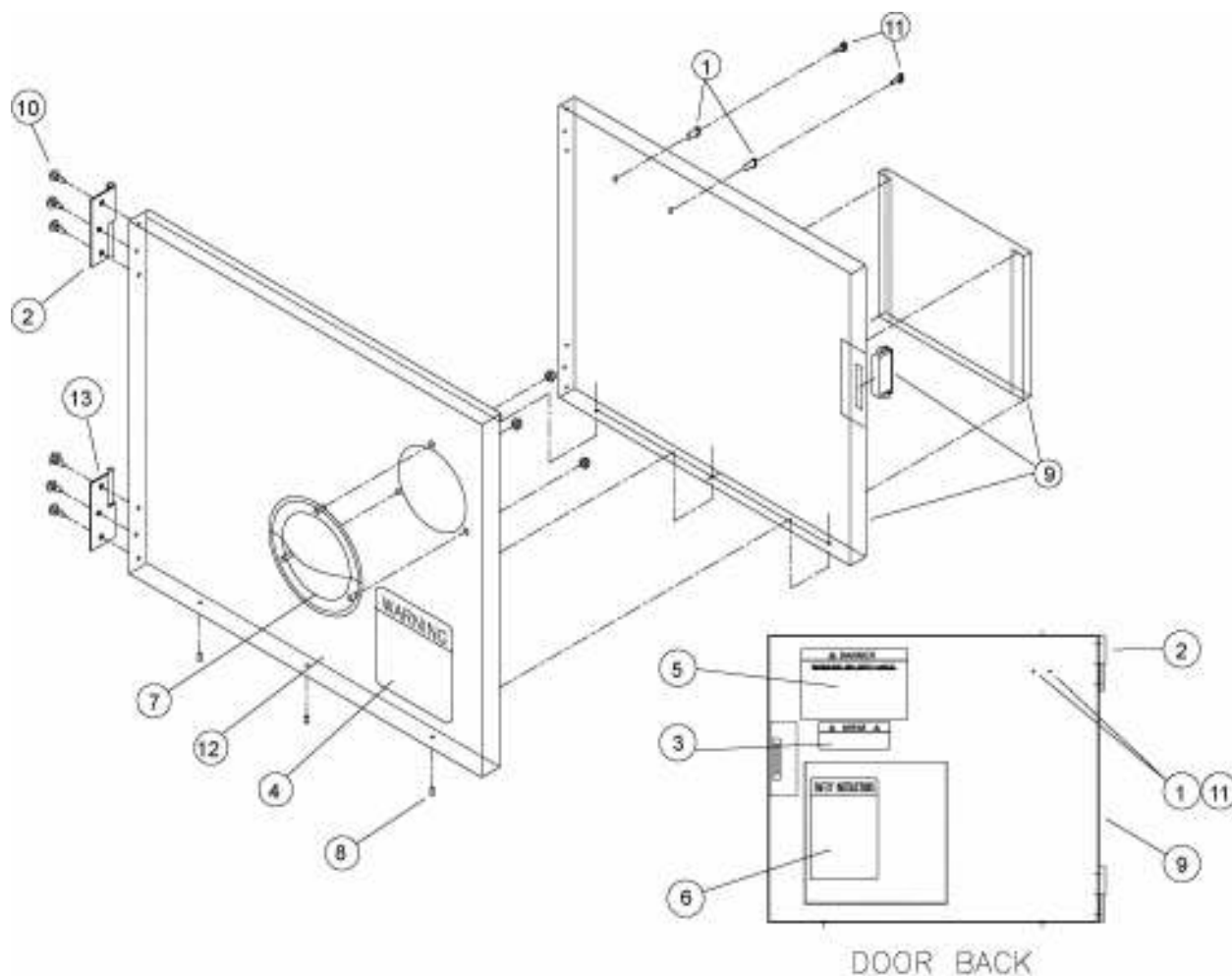

Table 3. Door Assembly Parts

ITEM #	PART #	QTY	DESCRIPTION
1	F0083	2	THREAD INSERT 10-24 STEEL
2	H0010	1	HINGE, LH PIN HALF
3	N0165	1	DECAL, NOTICE LOST MANUAL
4	N0175	1	DECAL, SLIPPING ADMONITIONS
5	N0176	1	DECAL, INSTR & SAFETY MANUAL
6	N0527	1	DECAL, SAFETY INSTR FRYERS
7	P0022	1	HANDLE, PULL SS P60-1010
8	RIV172	3	RIVET, 1/8 X 1/4 CS PLT POP
9	SB1951	1	INSIDE DOOR POCKET/MAGNET WELD BLF
10	SCR008	6	SCREW, 10 X 1/2 PHIL TRUSS HD
11	SCR383	2	SCREW, 10-24 X 1/2" PHIL TRUSS HD
12	WFKMA178	1	DOOR, FRYER OUTSIDE WELD
13	H0009	1	HINGE, RH PIN HALF

Figure 4. Drain Valve & Plugs

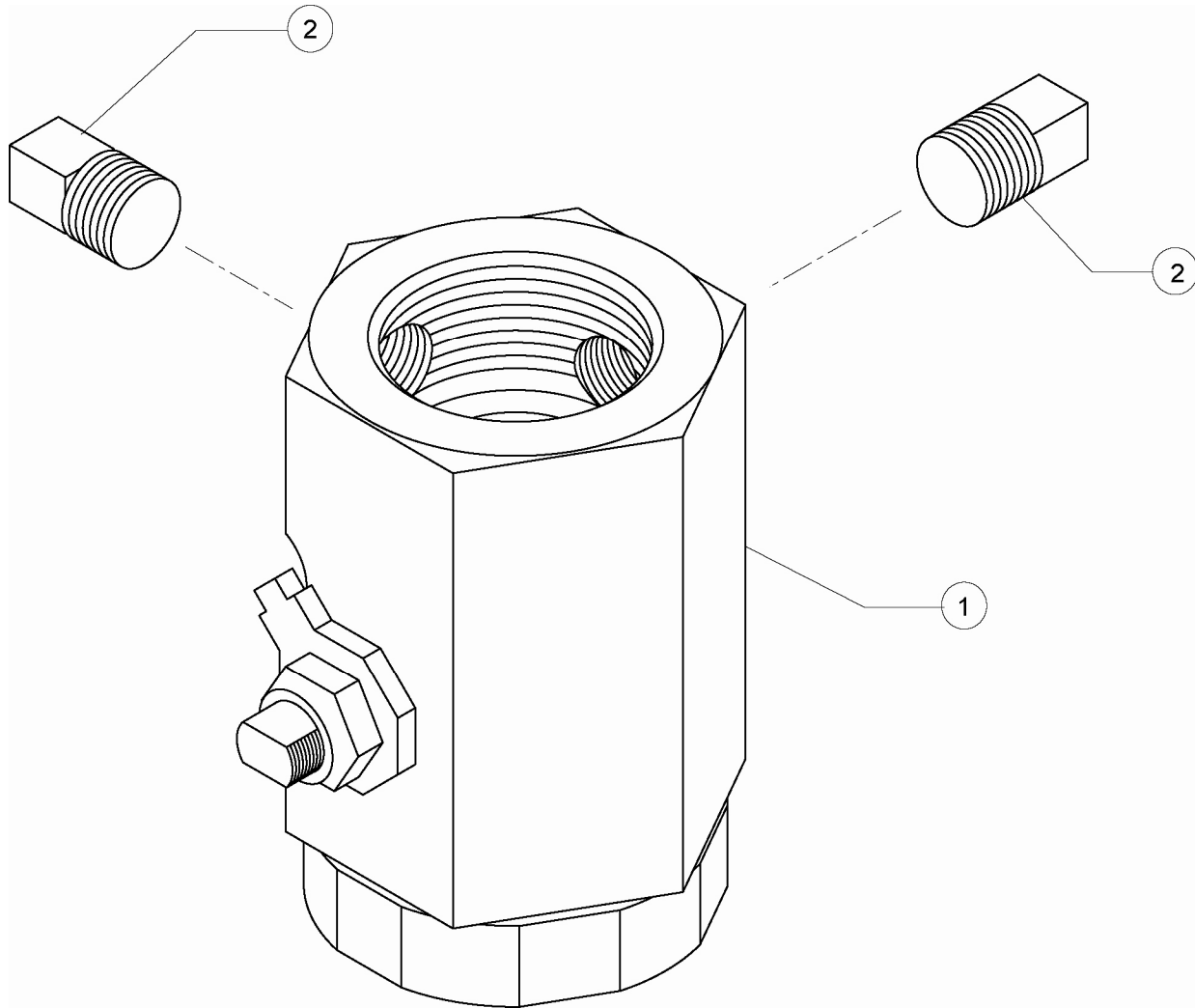

Table 4. Drain Valve & Plugs Parts

ITEM #	PART #	QTY	DESCRIPTION
1	MB19101000	1	DRAIN VALVE REPLACEMENT
2	FT0243	2	PLUG, 3/8" SQ HEAD PIPE

Figure 5. Drain/Motor/Piping Assembly

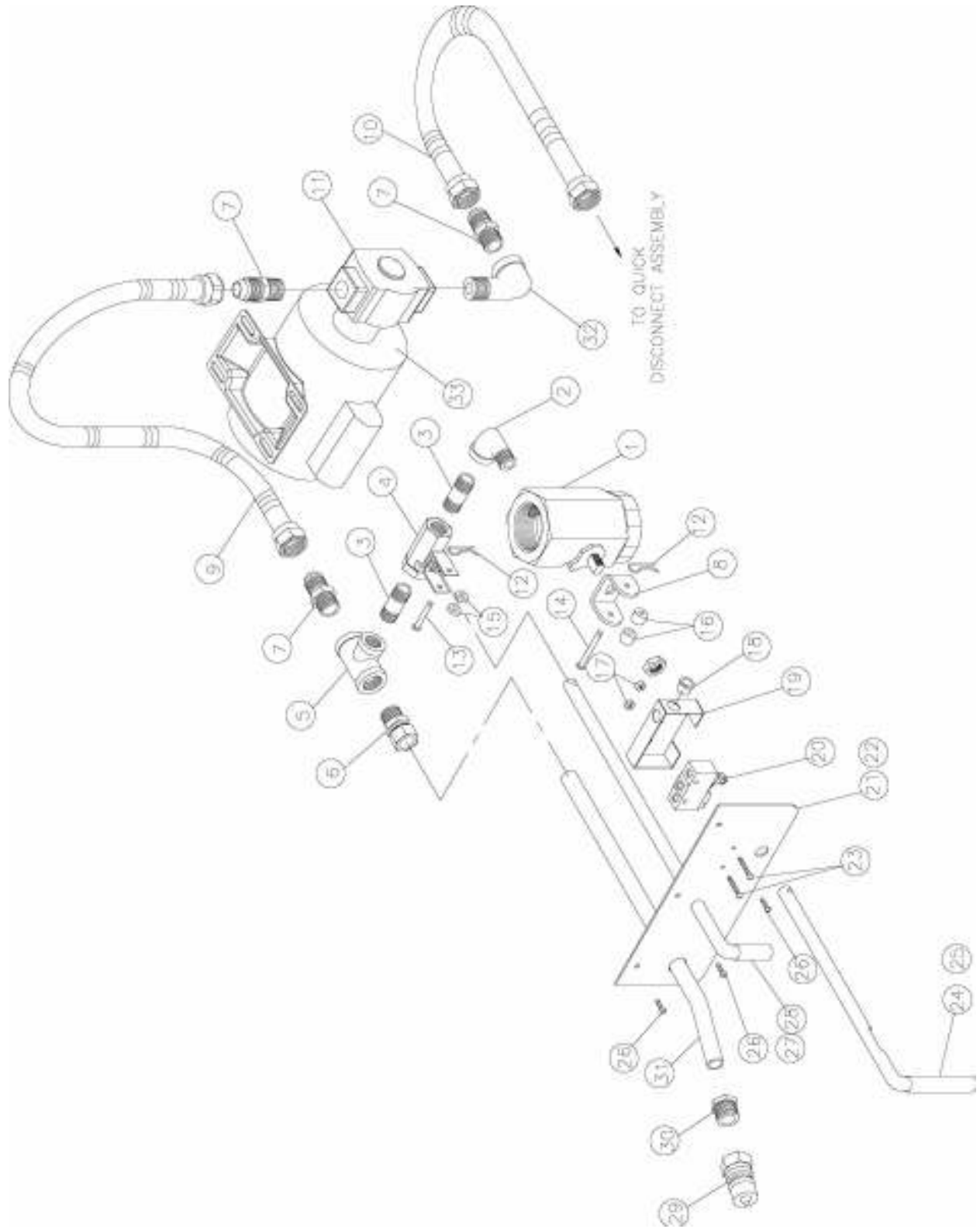

Table 5. Drain/Motor/Piping Assembly Parts

ITEM #	PART #	QTY	DESCRIPTION
1	MB19101000	1	DRAIN VALVE REPLACEMENT
2	FT0044	1	ELL, STREET 3/8 90 DEG BLACK
3	FT0412	2	NIPPLE, 3/8 NPT X 1 1/2 SCH 40
4	SB1314	1	BALL VALVE ASSY, FRYERS
5	FT0538	1	TEE, 1/2 X 1/2 X 3/8 BLK
6	FT0507	1	CONNECTOR, MALE 10FBU-S NKL PLTD
7	FT0536	3	COUPLING, 5/8 45° FLARE TO
8	FT0543	1	DRAIN VALVE BRACKET, FRYERS
9	TU0206	1	TUBING, 29" 1/2" ID
10	TU0205	1	TUBING, 12" 1/2" ID
11	P0070	1	PUMP ONLY FOR HAIGHT MOTOR
12	F0254	2	PIN, COTTER HAIRPIN #213
13	F0255	1	PIN, CLEVIS 3/16 X 1-1/4
14	F0253	1	PIN, CLEVIS 3/16 X 1 3/4
15	SP0014	2	SPACER, ALUM .5 X .125
16	SP0034	2	SPACER, DRAIN VALVE BRKT FRYERS
17	NUT253	2	NUT, 6-32 S/S 18-8 NYLON
18	F0158	1	BUSHING, BLK 1/2 HEYCO SNAP
19	LZ0130	1	SWITCH, ACT. COVER FKMA247
20	S0054	1	SWITCH, MICRO BZ-2RW822-A2
21	H0089	1	HANDLE SUPPORT PLATE
22	N0285	1	DECAL, BLF-F DRAIN HNDL PLATE
23	SCR194	2	SCREW, 6-32 X 1 SL RD HD MS
24	H0215	1	HANDLE, DRAIN VALVE BLF
25	C0672	1	COVER, DRAIN HANDLE RED
26	SCR006	3	SCREW, 8 X 1/2 PHIL PAN HEAD
27	MA19100508	1	FILL VALVE HANDLE, FRYERS
28	C0668	1	COVER, FILL HANDLE BLACK
29	P0081	1	PLUG, F-H4F4-7-7 QUIK DISCONN
30	B0851	1	BUSHING, BLK HEX REDUCING
31	MA19100800	1	TUBING, TEE TO DISCONNECT
32	FT0132	1	ELL, STREET 1/2 90 DEG BLACK
33	M0053	1	MOTOR, LEESON LESS CORD/PUMP

Figure 6. Front Panel BLF-F

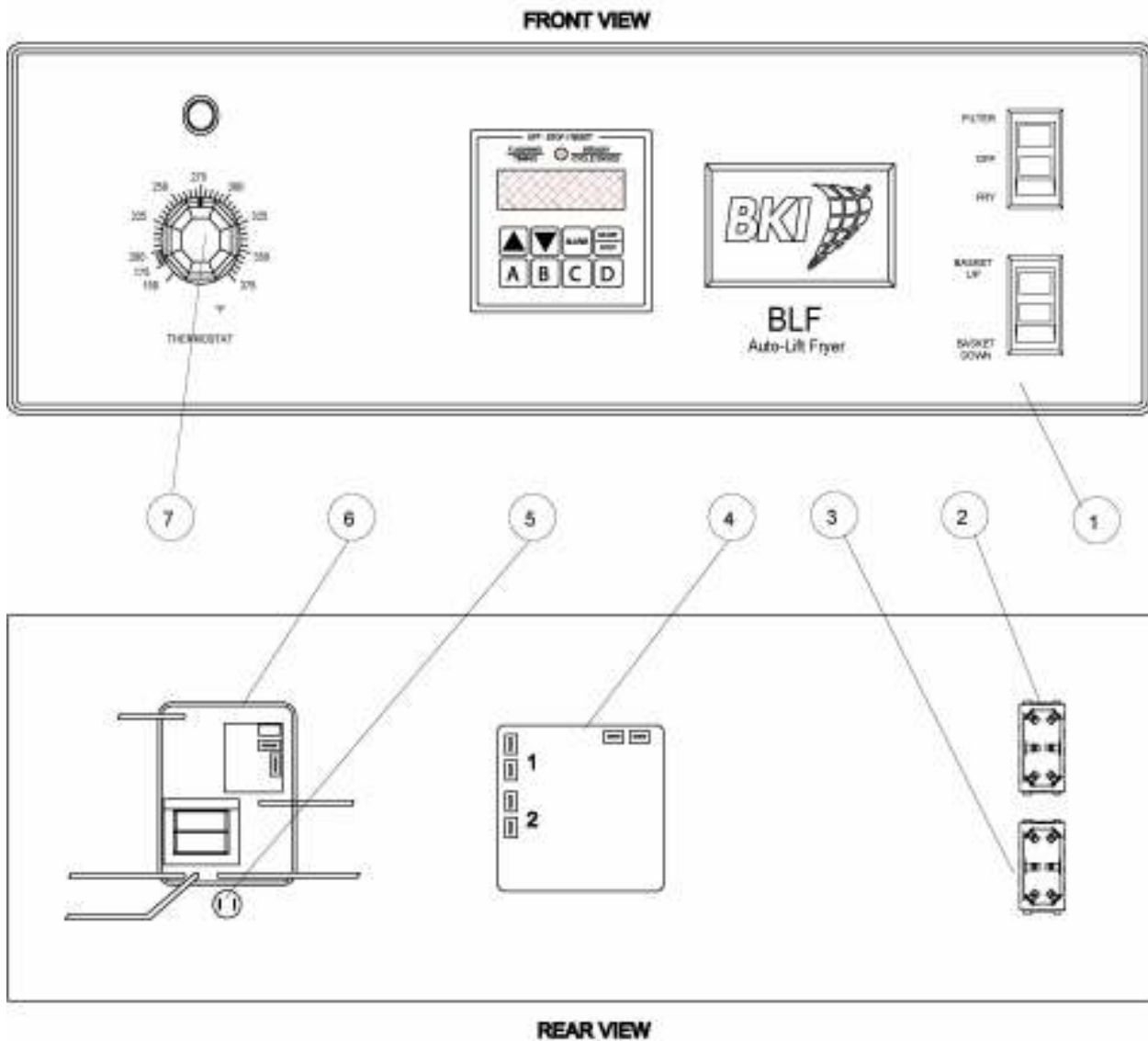

Table 6. Front Panel BLF-F Parts

ITEM #	PART #	QTY	DESCRIPTION
1	N0523	1	DECAL, CTL PNL BLF-F
2	S0127	1	SWITCH, ROCKER 2P,3 POS
3	S0104	1	SWITCH, RKR DPDT 15A 250V LAMP
4	TI0032	1	TIMER, 230V DIGITAL 4 BUTTON
5	PL0004	1	PILOT LIGHT, ROUND 250V
6	T0075	1	THERMOSTAT, SOLID STATE FRYER
7	K0040	1	KNOB, S/S STRAT T0075

Figure 7. Front Panel BLF-FC

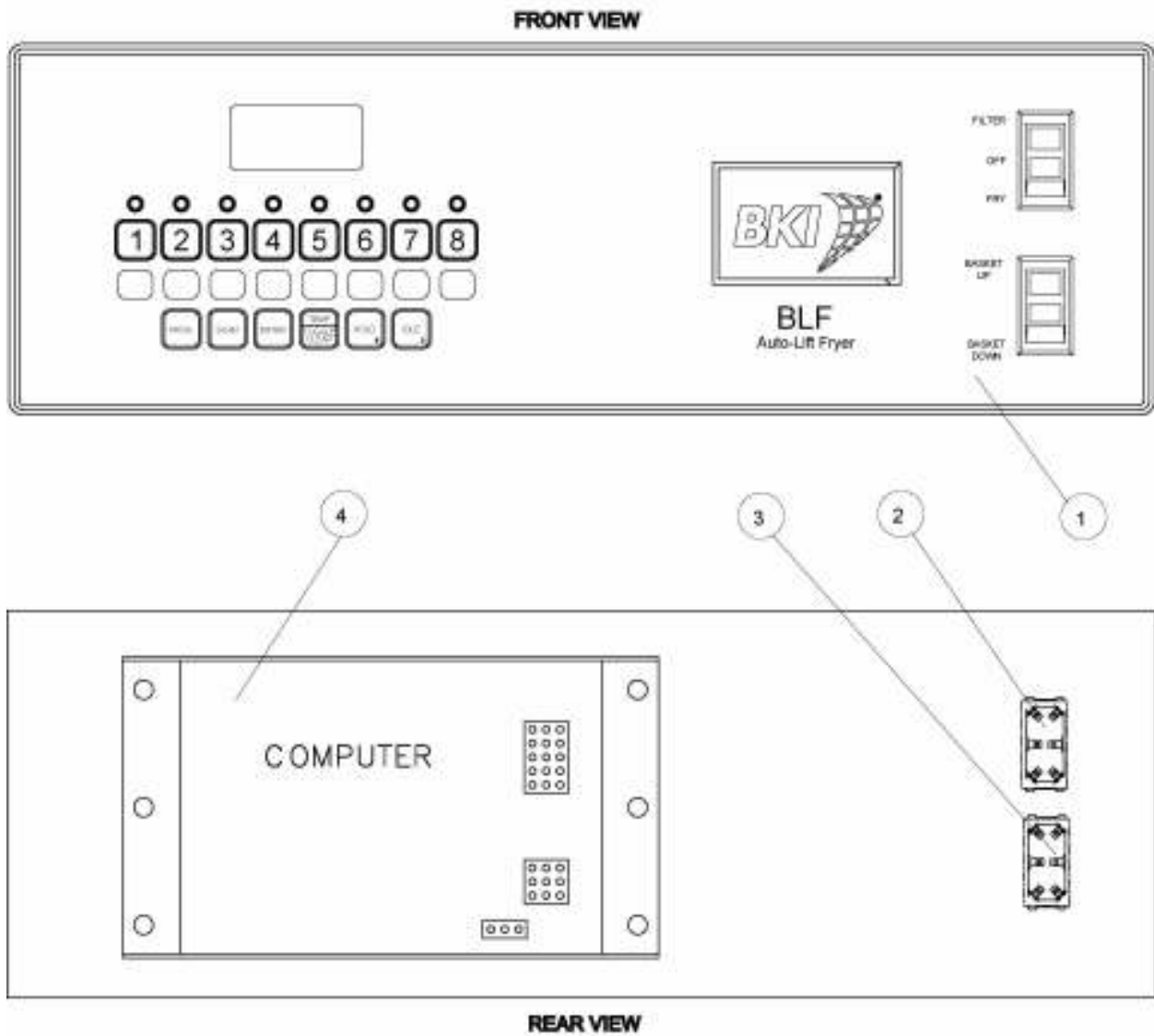

Table 7. Front Panel BLF-FC Parts

ITEM #	PART #	QTY	DESCRIPTION
1	N0525	1	DECAL, CTL PNL BLF-FC
2	S0127	1	SWITCH, ROCKER 2P, 3 POS
3	S0104	1	SWITCH, RKR DPDT 15A 250V LAMP
4	CP0039	1	CONTROLLER, VFD LESS HARNESS

Figure 8. Rear Panel BLF-F

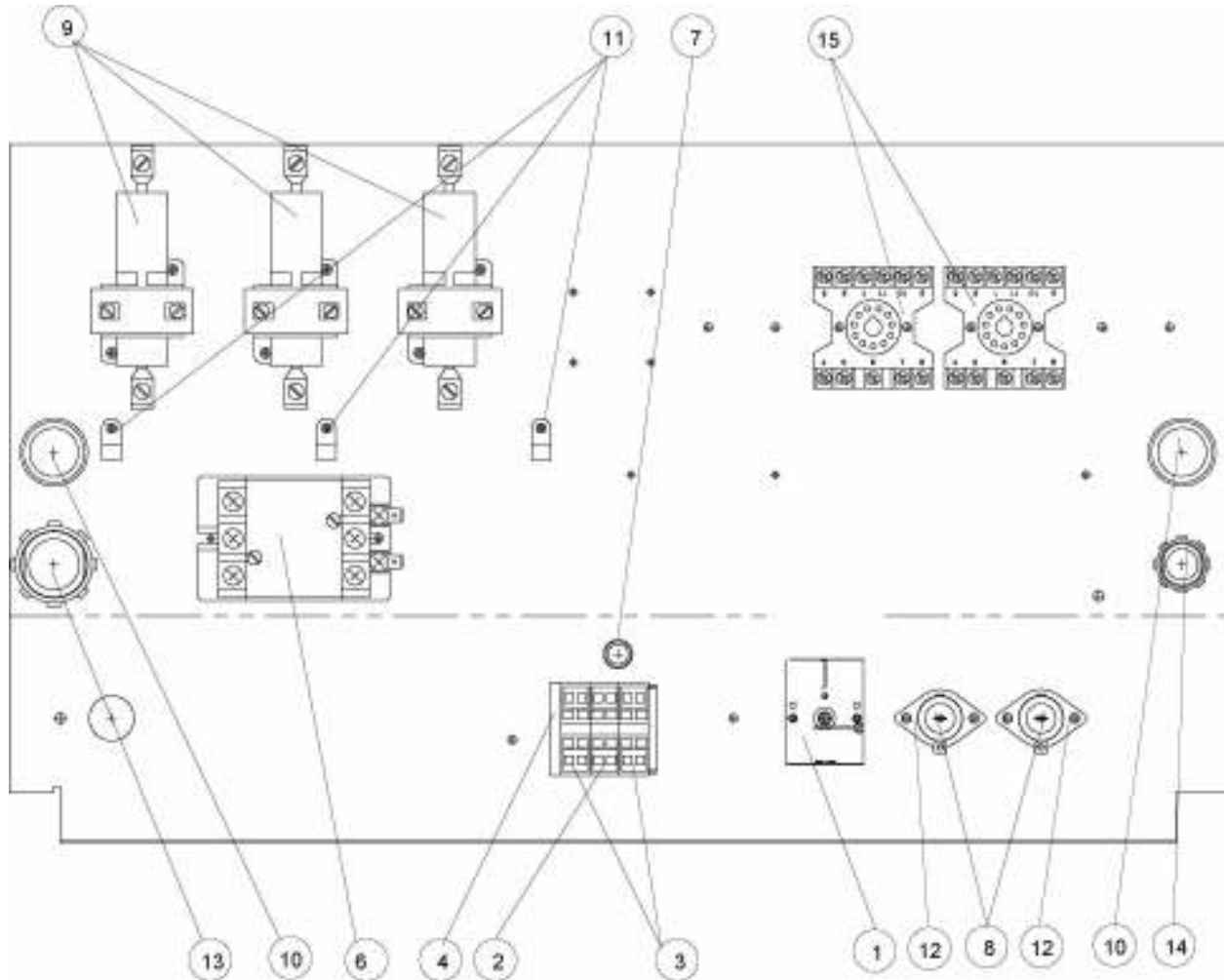

Table 8. Rear Panel BLF-F Parts

ITEM #	PART #	QTY	DESCRIPTION
1	T0036	1	THERMOSTAT, HI LIMIT 540 DEG
2	TB0064	1	TERM BLOCK 4 CONDUCTOR CTR
3	TB0065	2	TERM BLOCK 4 CONDUCTOR W/MTG FOOT
4	TB0068	1	TERM BLOCK END PLATE
5	TB0069	1	TERM BLOCK JUMPER BAR (not shown)
6	R0148	1	RELAY, 3 POLE 42CF35AG
7	F0158	1	BUSHING, BLK 1/2 HEYCO SNAP
8	F0097	2	FUSE, 15A 300V SC15 TIME DELAY
9	R0134	3	RELAY, MERCURY MDI 60NO220A
10	F0154	2	BUSHING, BLK 1-3/16 HEYCO SNAP
11	F0342	3	CLAMP, CABLE 3/16"
12	FH0001	2	FUSE HOLDER, 15A 300V HPF-EE
13	FT0080	1	CONNECTOR, BOX #7483 1"
14	FT0277	1	PLUG, HOLE 7/8" (1/2" CONDUIT)
15	R0131	2	RELAY. PLUG IN 3PDT 240V COIL

Figure 9. Rear Panel BLF-FC

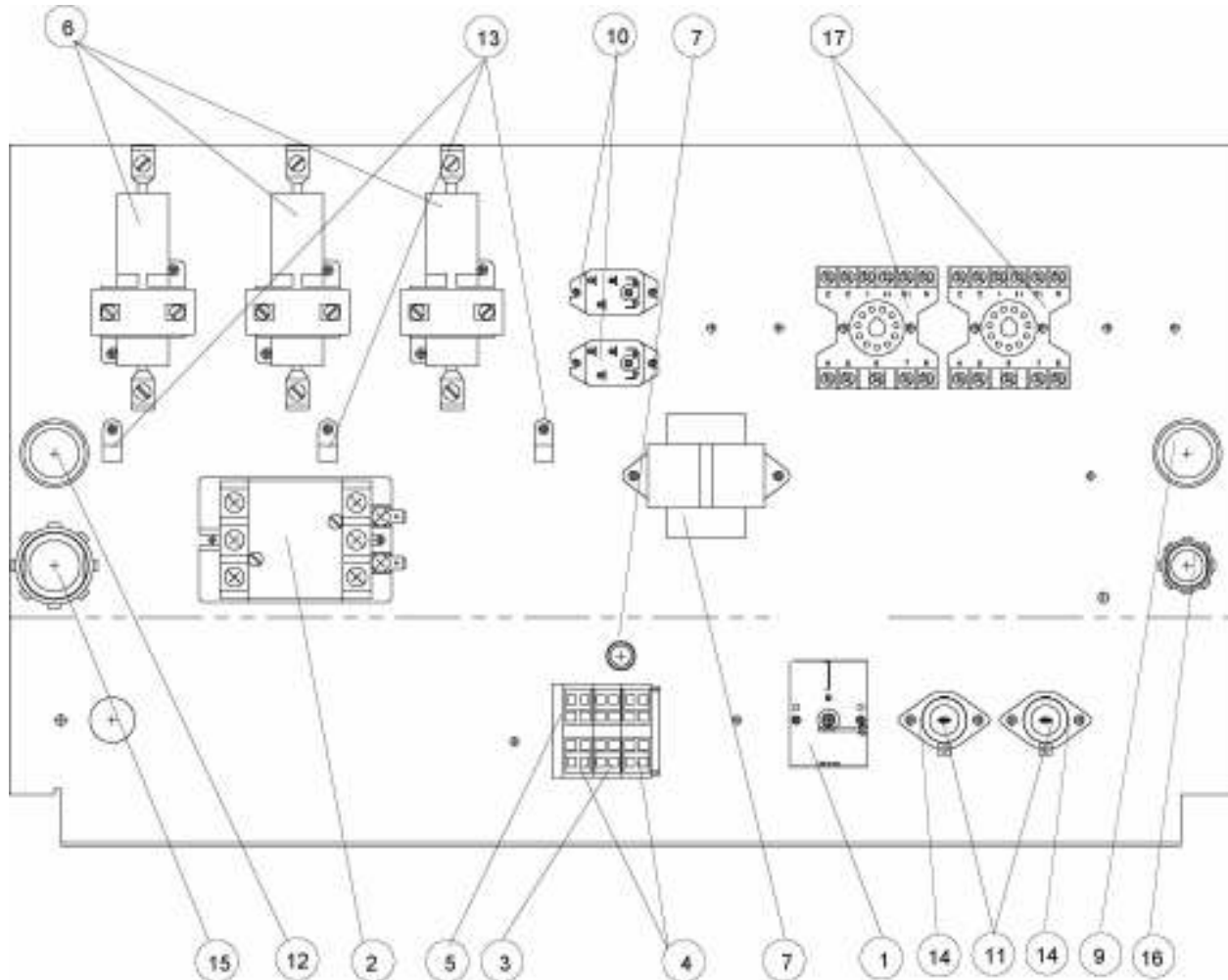

Table 9. Rear Panel BLF-FC Parts

ITEM #	PART #	QTY	DESCRIPTION
1	T0036	1	THERMOSTAT, HI LIMIT 540 DEG
2	R0148	1	RELAY, 3 POLE 42CF35AG
3	TB0064	1	TERM BLOCK 4 CONDUCTOR CTR
4	TB0065	2	TERM BLOCK 4 CONDUCTOR W/MTG FOOT
5	TB0068	1	TERM BLOCK END PLATE
6	R0134	3	RELAY, MERCURY MDI 60NO220A
7	W0054	1	TRANSFORMER ASSY 240V
8	TB0069	1	TERM BLOCK JUMPER BAR (not shown)
9	F0154	2	BUSHING, BLK 1-3/16 HEYCO SNAP
10	R0044	2	RELAY, X-40, SGL FRYER
11	F0097	2	FUSE, 15A 300V SC15 TIME DELAY
12	F0158	1	BUSHING, BLK 1/2 HEYCO SNAP
13	F0342	3	CLAMP, CABLE 3/16"
14	FH0001	2	FUSE HOLDER, 15A 300V HPF-EE
15	FT0080	1	CONNECTOR, BOX #7483 1"
16	FT0277	1	PLUG, HOLE 7/8" (1/2" CONDUIT)
17	R0131	2	RELAY. PLUG IN 3PDT 240V COIL

Figure 10. Oil Vat Assembly

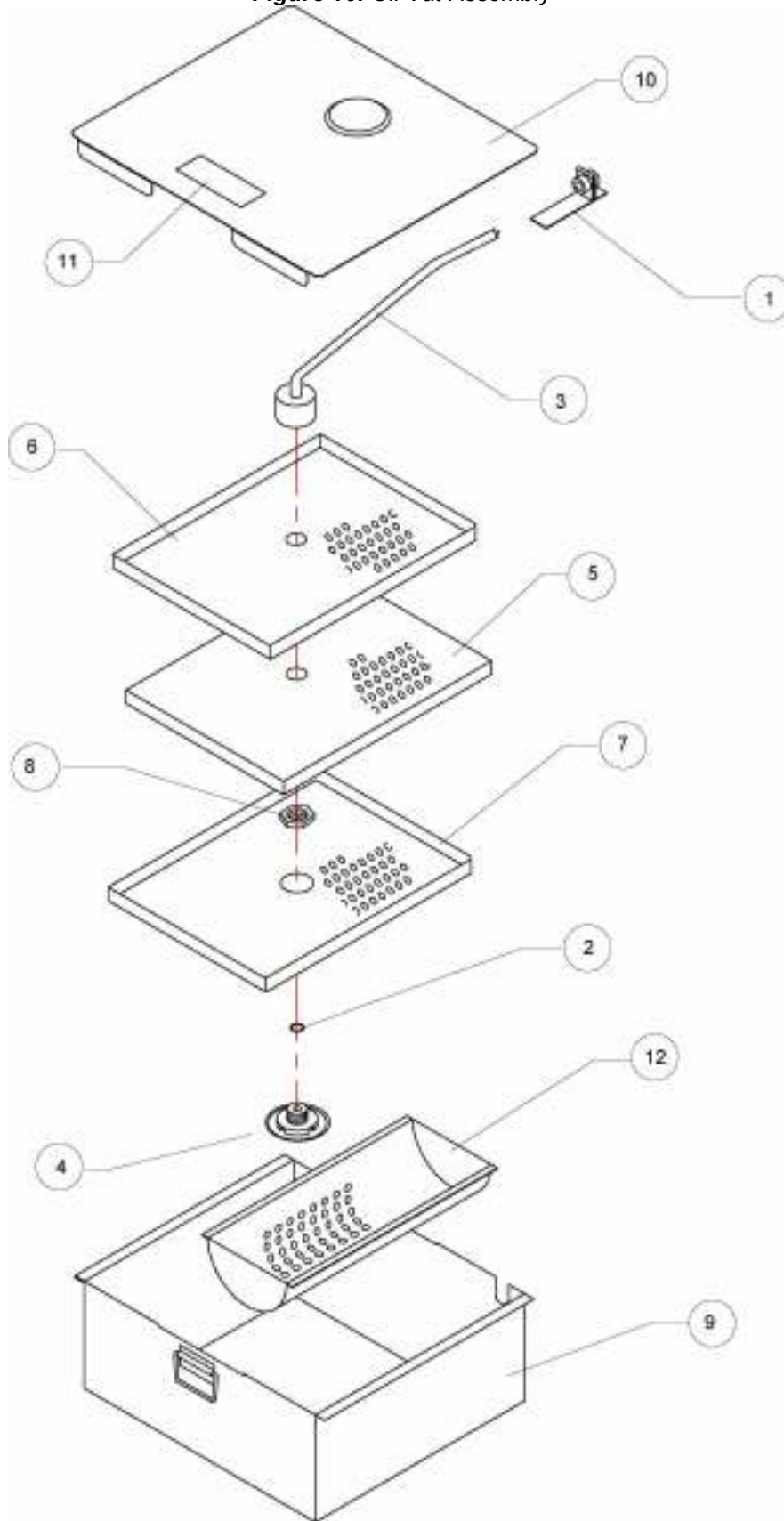

Table 10. Oil Vat Assembly Parts

ITEM #	PART #	QTY	DESCRIPTION
1	SB1991	1	QUIK DISCONNECT BRACKET WELDMENT
2	O0013	1	O-RING, FLUOROCARBON V680-70
3	WB16010400	1	FILTER VAT TUBE WELD, BLF
4	SB7659	1	FILTER SCREEN FITTING SPOTWELD
5	FS0003	1	FILTER SCREEN, TOP
6	FS0002	1	FILTER SCREEN, INTERCEPTOR
7	FS0001	1	FILTER SCREEN, BOTTOM
8	FC0004	1	NUT SCREEN RETAINING BLF-F &
9	WB16010600	1	FILTER VAT WELD QUIK DISC
10	FKMA357	1	COVER, FILTER VAT
11	N0395	1	DECAL, VAT COVER SAFETY WARN
12	SB7675	1	CRUMB BASKET WELD

Figure 11. Quick Disconnect Assembly

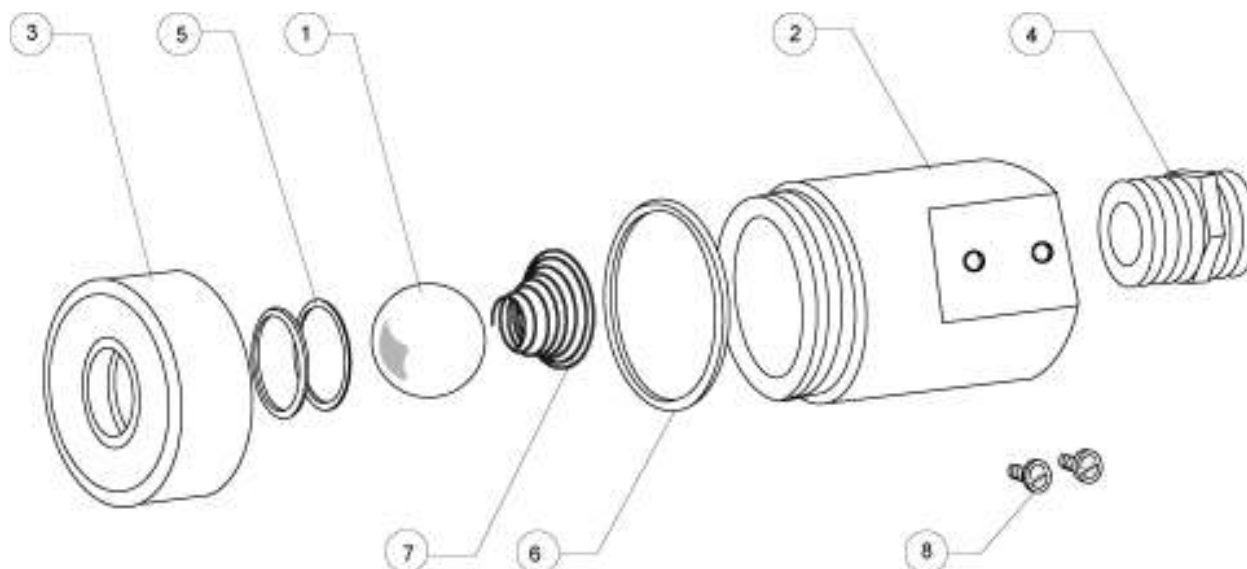

Table 11. Quick Disconnect Assembly Parts

ITEM #	PART #	QTY	DESCRIPTION
1	B0996	1	BALL, 11/16" STEEL BEARING
2	FT0429	1	QUIK DISCONNECT, PUMP SIDE
3	FT0500	1	QUIK DISCONNECT, VAT SIDE
4	FT0536*	1	COUPLING, 5/8 45° FLARE TO
5	O0013	2	O-RING, FLUOROCARBON V680-70
6	O0014	1	O-RING, PARKER #2-124 LARGE
7	S0138	1	SPRING, FOR QUIK DISCONNECT
8	SCR453*	2	SCREW, #10 24X3/8" WASHERED

* - Not included with SB1997S

Figure 12. Terminal Block Assembly

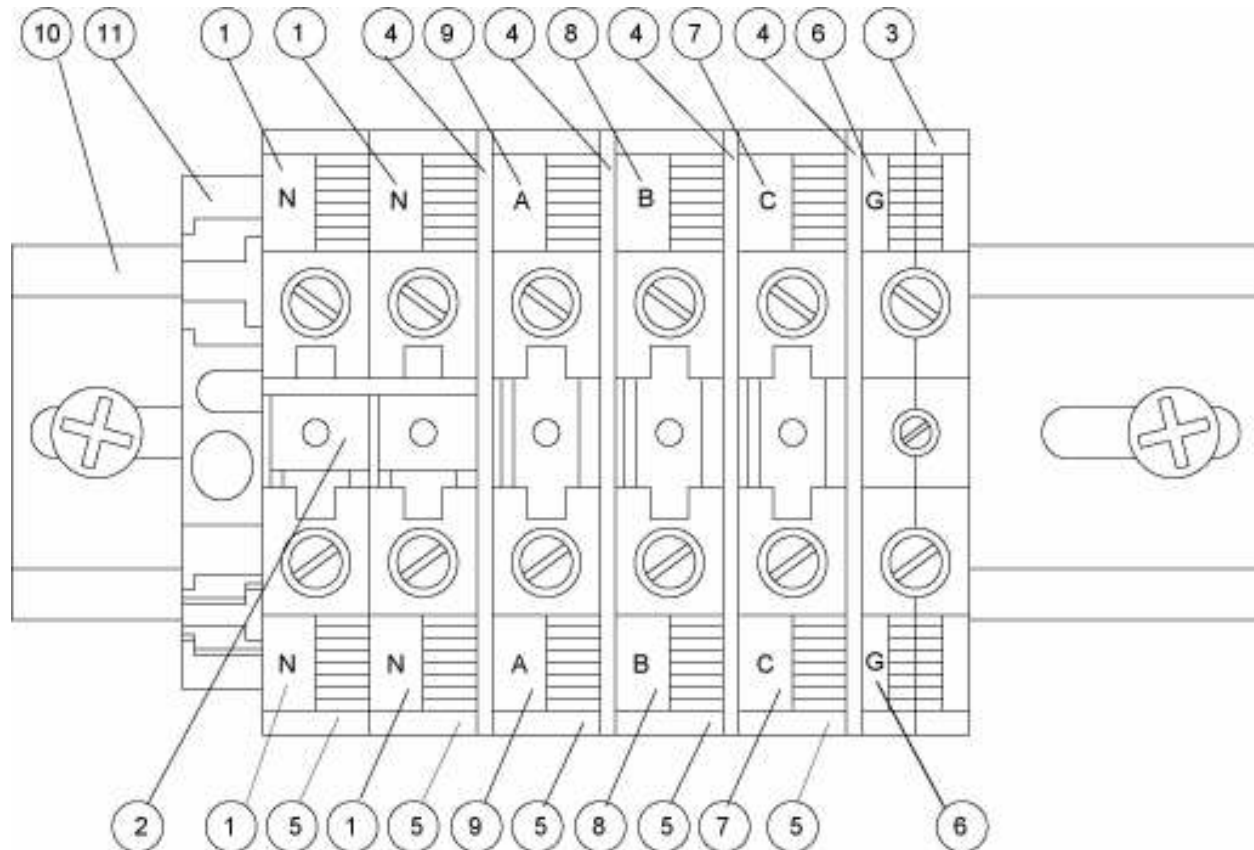

Table 12. Terminal Block Assembly Parts

ITEM #	PART #	QTY	DESCRIPTION
1	TB0044-N	4	TERM BLOCK TAGS "N"
2	TB0049	1	TERM BLOCK 2 POLE JUMPER
3	TB0048	1	TERM BLOCK GROUND BLOCK
4	TB0047	4	TERM BLOCK END PLATE WAP
5	TB0046	5	TERM BLOCK, WDU10 #102030
6	TB0044-G	2	TERM BLOCK TAGS PIC/GROUND
7	TB0044-C	2	TERM BLOCK TAGS "C"
8	TB0044-B	2	TERM BLOCK TAGS "B"
9	TB0044-A	2	TERM BLOCK TAGS "A"
10	MA10503700	1	RAIL CUT TO 3.94" TB0045
11	TB0051	1	TERM BLOCK END BRKT EW35

Accessories

Description	Accessory #	Figure #	Item #
BASKET, BLF	B0112	Figure 13	1
BASKET, BLF (GRANDE) - option	B0121	Figure 13	2
BRUSH, DRAIN (LONG WHITE)	B0075	Figure 13	3
BRUSH, L TIPPED 40152	B0063	Figure 13	4
BRUSH, POT SCRUBBER, WHITE	B0049	Figure 13	5
CORD SET, BLF-FC 7' - option	SB7655	Figure 13	6
FILTER HOSE, FEMALE SOCKET - option	SB2332	Figure 13	7
FILTER VAT DOLLY BLF-F - option	SB7650	Figure 13	8
GLOVE, NEOPRENE	G0089	Figure 13	9
FILTER, FKM-F 13.5 X 20.5	FI0007	Figure 13	10
RESTRAINT	FT0279	Figure 13	11
POT STIR STICK FOR 75# BLF - option	P0149	Figure 13	12
STORAGE COVER - option	AN16007300	Figure 14	Table 13

Figure 13. Accessories



Table 13. Storage Cover Assembly Parts

ITEM #	PART #	QTY	DESCRIPTION
1	FB16009303	1	HANGER, FRY POT COVER BLF
2	SCR136	1	SCREW, 10-24 X 3/8 SLTD TRUSS
3	N0358	1	DECAL, BLF COVER CAUTION
4	K0044	1	KNOB, LARGE COVER, #3200
5	FB16007003	1	COVER, STORAGE BLF TOP
6	N0162	1	DECAL, CAUTION HOT SURFACES
7	SCR007	2	SCREW, 8 X 3/4 PHIL TRUSS HD
8	SCR005	1	SCREW, 8 X 1/2 PHIL TRUSS HD

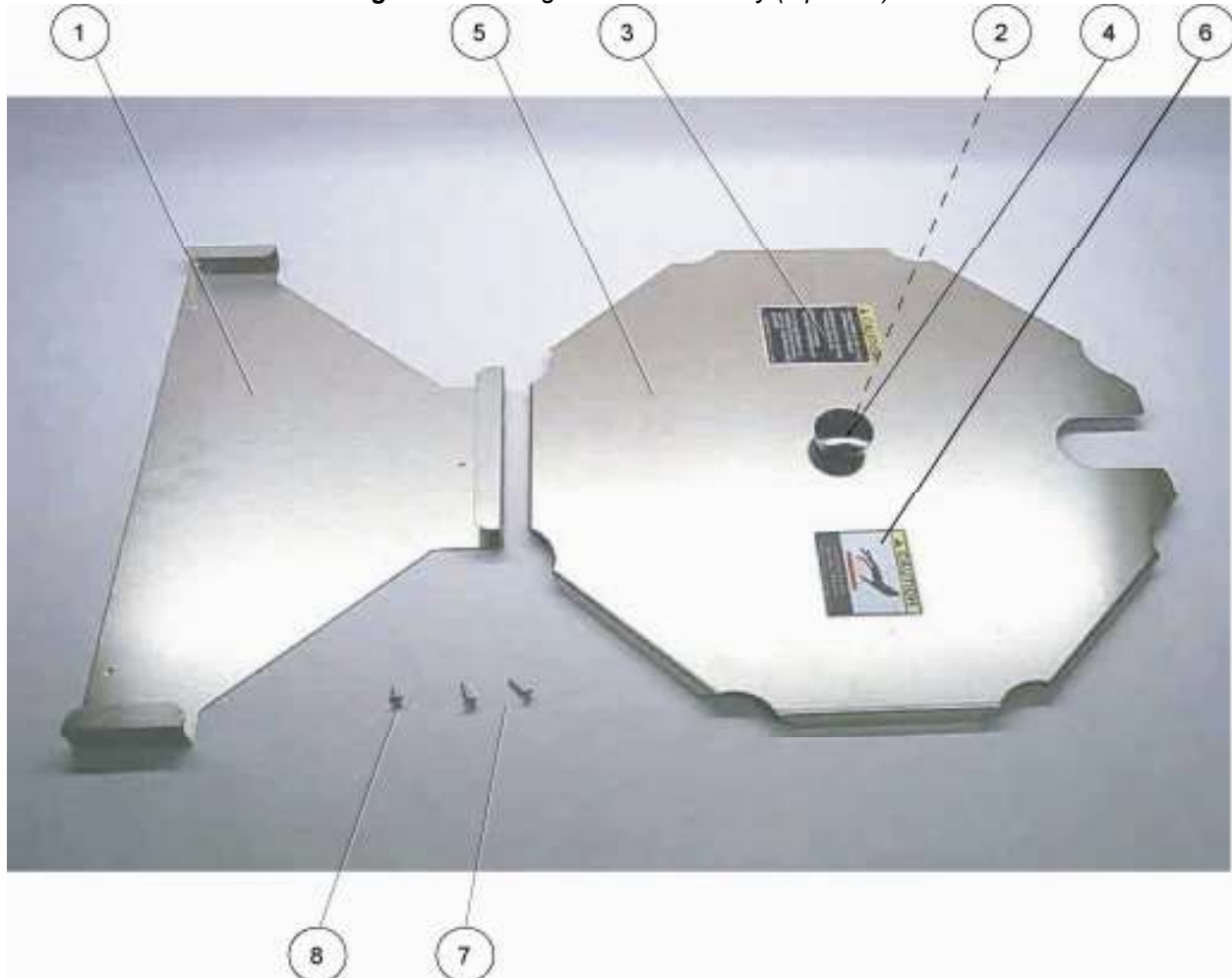
Figure 14. Storage Cover Assembly (Optional)

Components

Description	Component #	Figure #	Item #
CALROD, 208V 5675W FKM-F CALROD, 240V 5675W FKM-F	C0030 C0031	Figure 15	1
CASTER, W/TOP PLATE 5"	C0406	Figure 15	2
CAPACITOR, 7.5 MFD 370 VAC	CP0102	Figure 15	3
WASHER, PTFE-FRYER CALROD	FT0059	Figure 15	4
HINGE, SLIP WING RH	H0051	Figure 15	5
HINGE, SLIP WING LH	H0052	Figure 15	6
BRACKET, CALROD FKMA258	LZ0006	Figure 15	7
BRACKET BACK PLATE FKMA259	LZ0007	Figure 15	8
MOTOR, BALL DRIVE ACTUATOR	M0084	Figure 15	9
NUT, 5/8-18 HEX	NUT237	Figure 15	10
SWITCH 1A 250VAC SPDT	S0353	Figure 15	11
PROBE ASSEMBLY KIT, COMPUTER	SB1938	Figure 15	12
THERMISTER PROBE/FTGS ASSEMBLY	SB7656	Figure 15	13
FILTER BAG CLIP FKM-F	ST0015	Figure 15	14
COLLAR/LIFT ADJ WELD BLF	WA16015600	Figure 15	15
BASKET LIFT ARM WELD, LINEAR ACTUATOR	WB16015800	Figure 15	16
WASHER, 5/8 INT TOOTH LOCK	WSH107	Figure 15	17

Figure 15. Components



1



2



3



4



5



6



7



8



9



10



11



12



13



14



15



16



17

Wiring Diagrams

Refer to the table below to find the wiring diagram associated with your unit.

Wiring Diagram	Figure #
BLF/BLF-F 208/220V/240V, 3 Phase	Figure 16
BLF/BLF-F 220V/380V, 230V/400V, 240V/415V, 3 Phase	Figure 17
Domestic BLF-FC 208V/220V/240V	Figure 18
European BLF-FC 220V/380V, 230V/400V, 240V/415V	Figure 19

Figure 16. BLF/BLF-F 208/220V/240V, 3 Phase

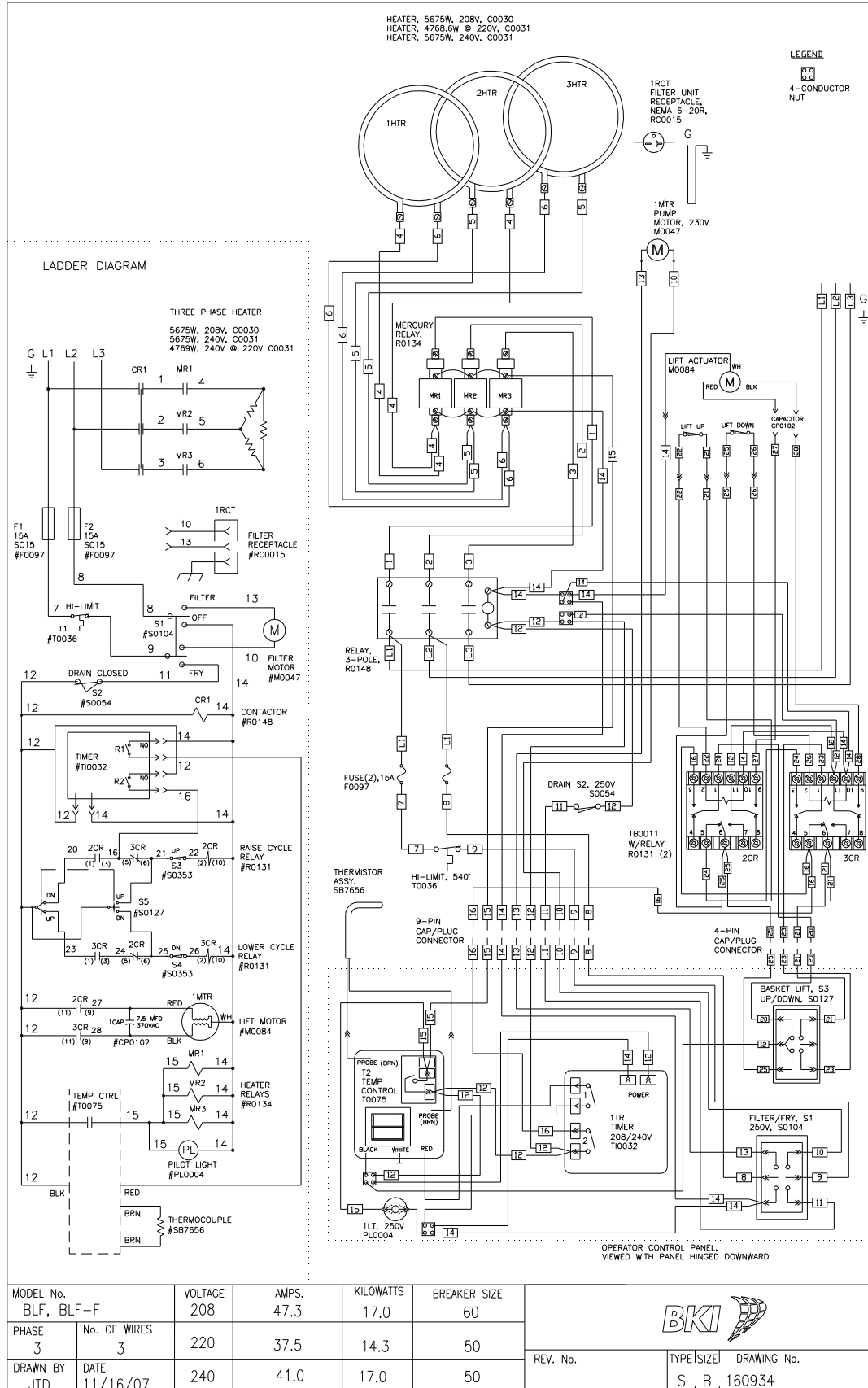

Figure 17. BLF/BLF-F 220V/380V, 230V/400V, 240V/415V, 3 Phase

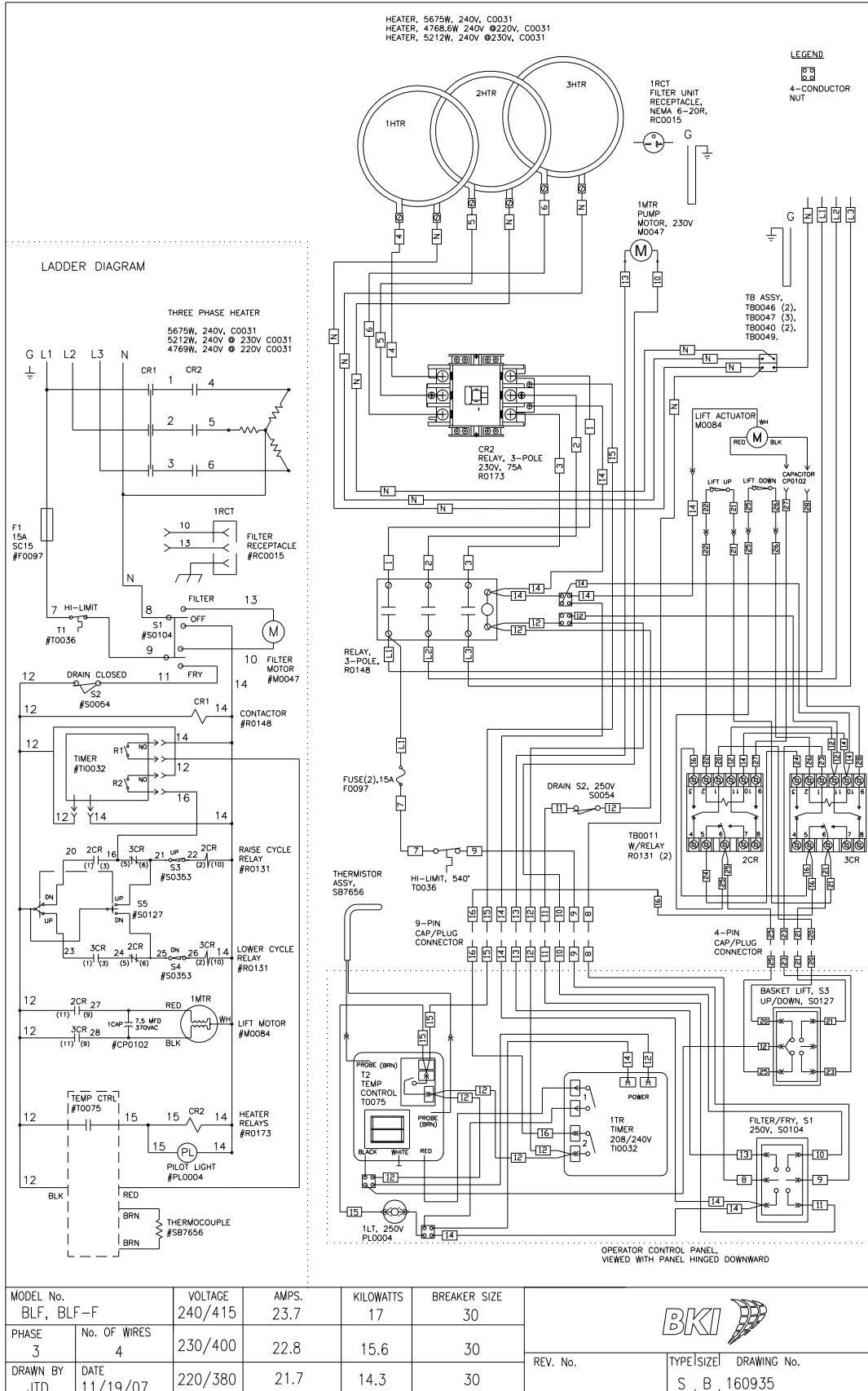

Figure 18. Domestic BLF-FC 208V/220V/240V (Sheet 1 of 4)

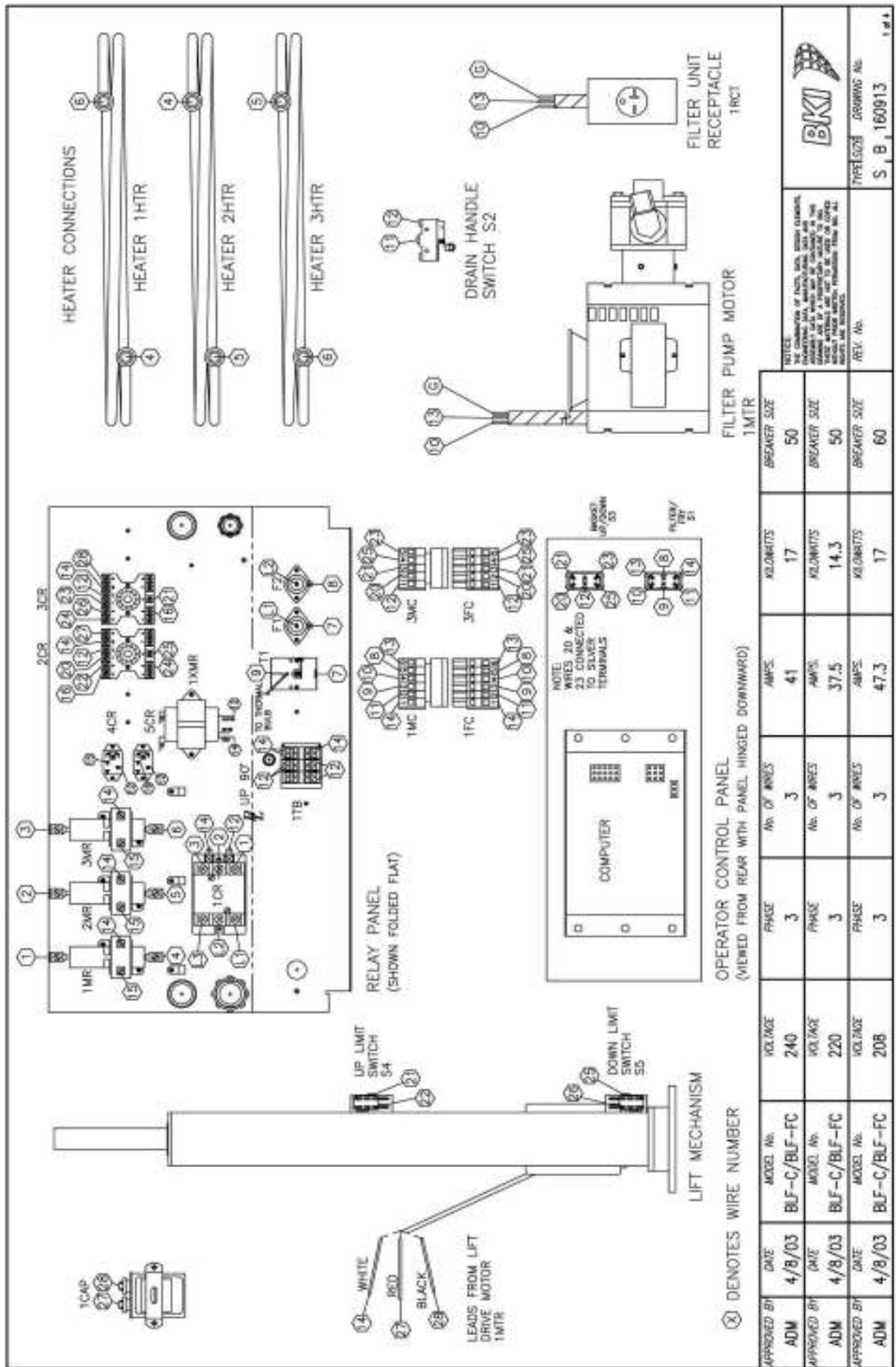

Figure 18. Domestic BLF-FC 208V/220V/240V (Sheet 2 of 4)

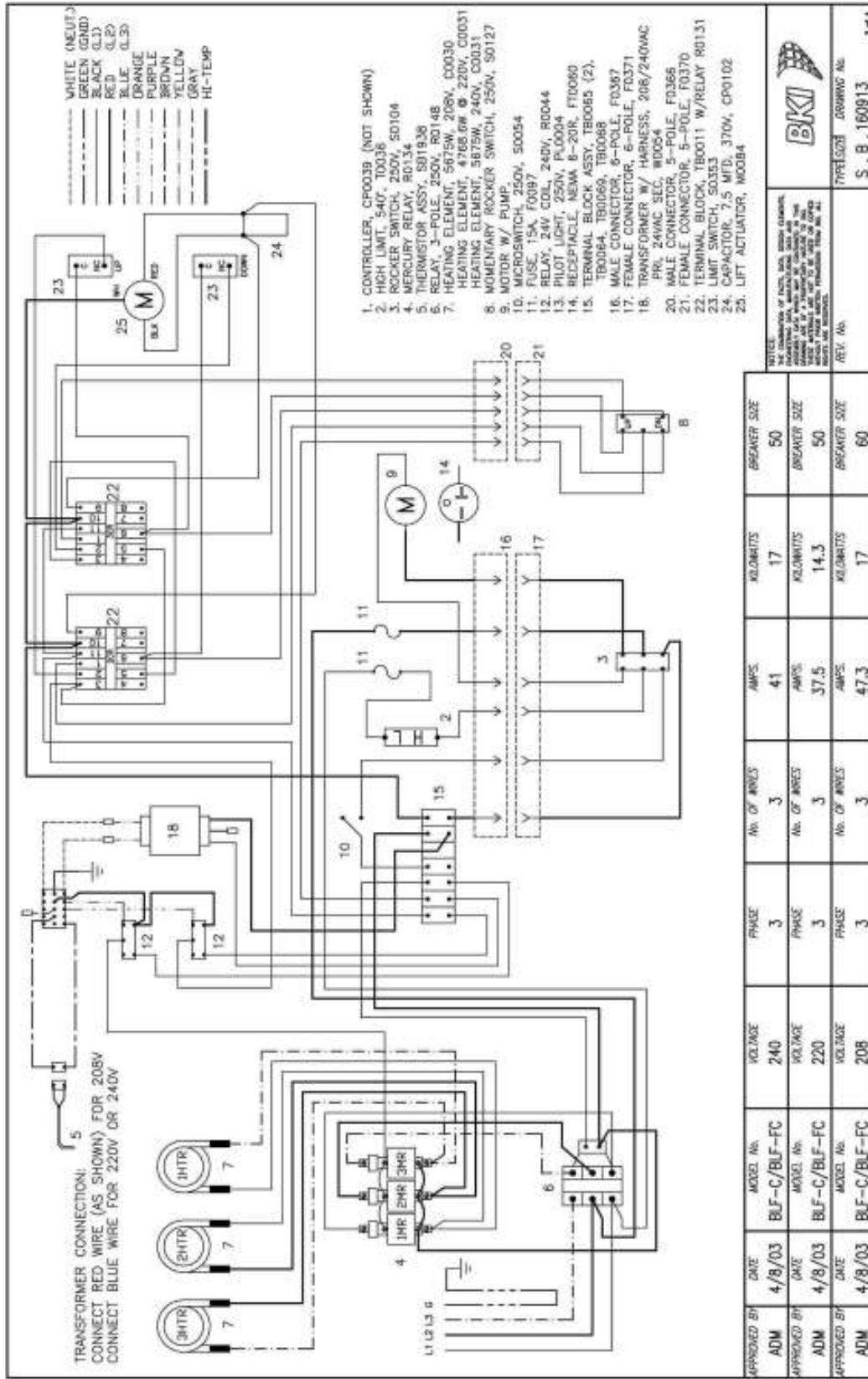

Figure 18. Domestic BLF-FC 208V/220V/240V (Sheet 3 of 4)

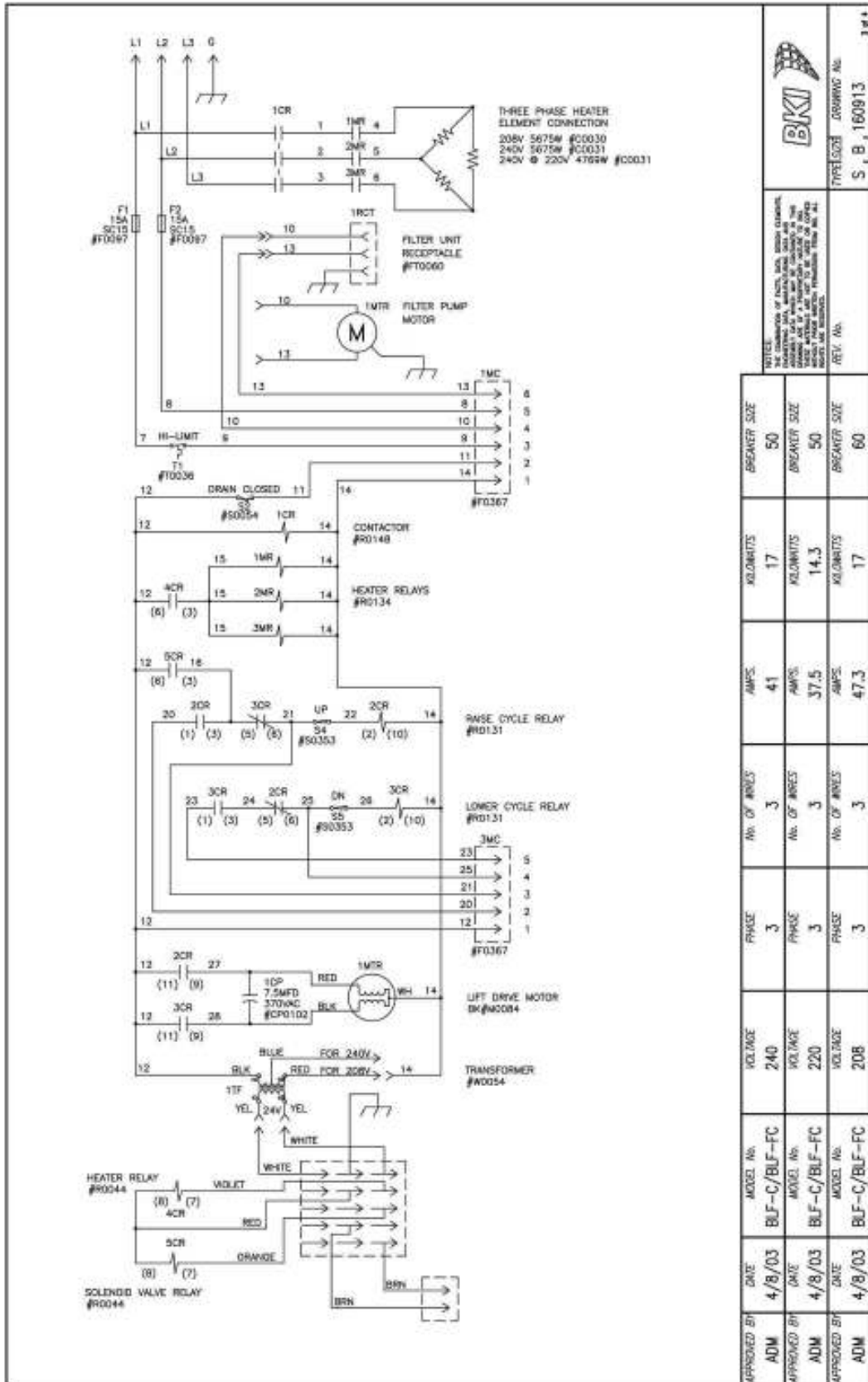

Figure 18. Domestic BLF-FC 208V/220V/240V (Sheet 4 of 4)

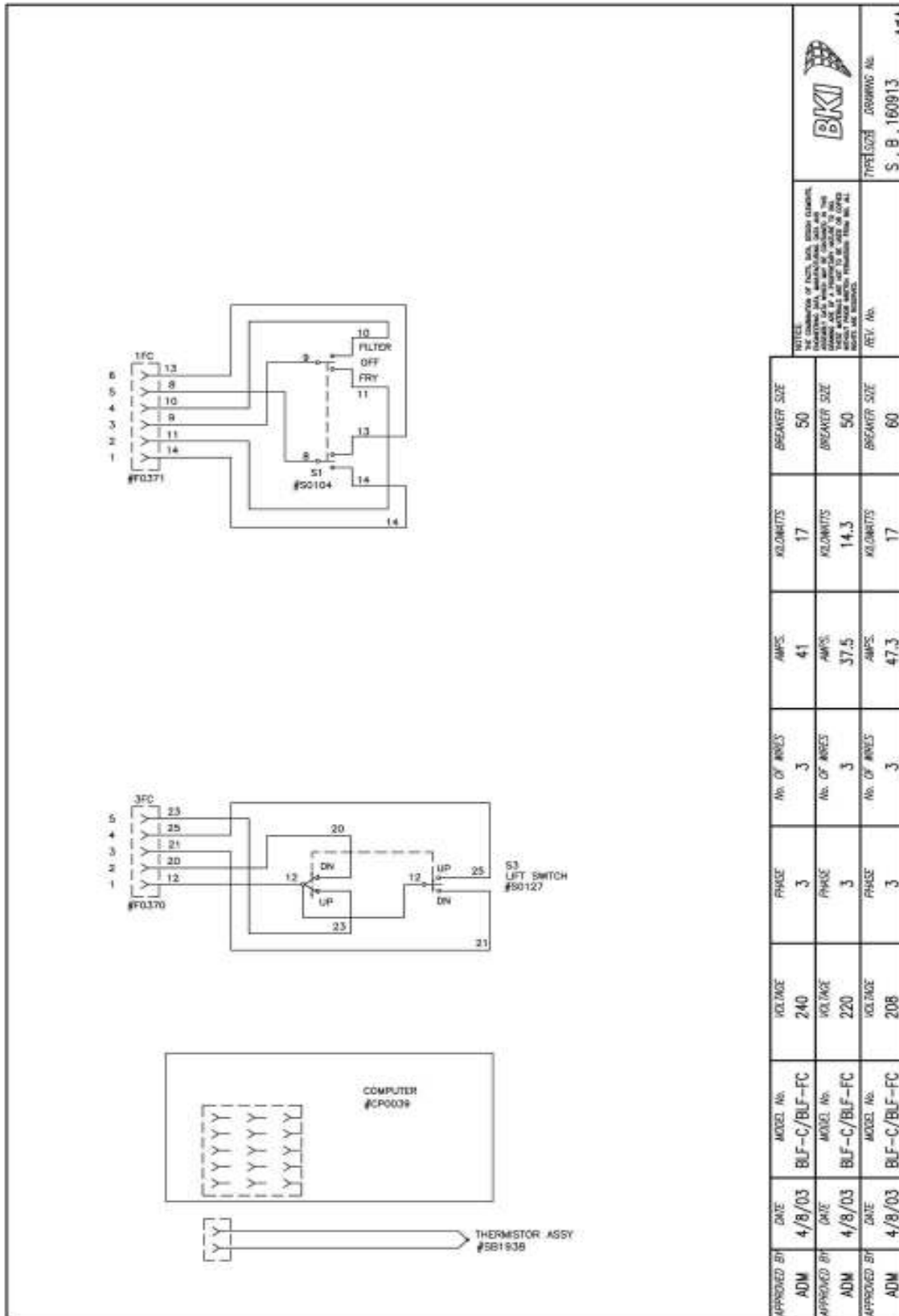

Figure 19. European BLF-FC 220V/380V, 230V/400V, 240V/415V (Sheet 1 of 4)

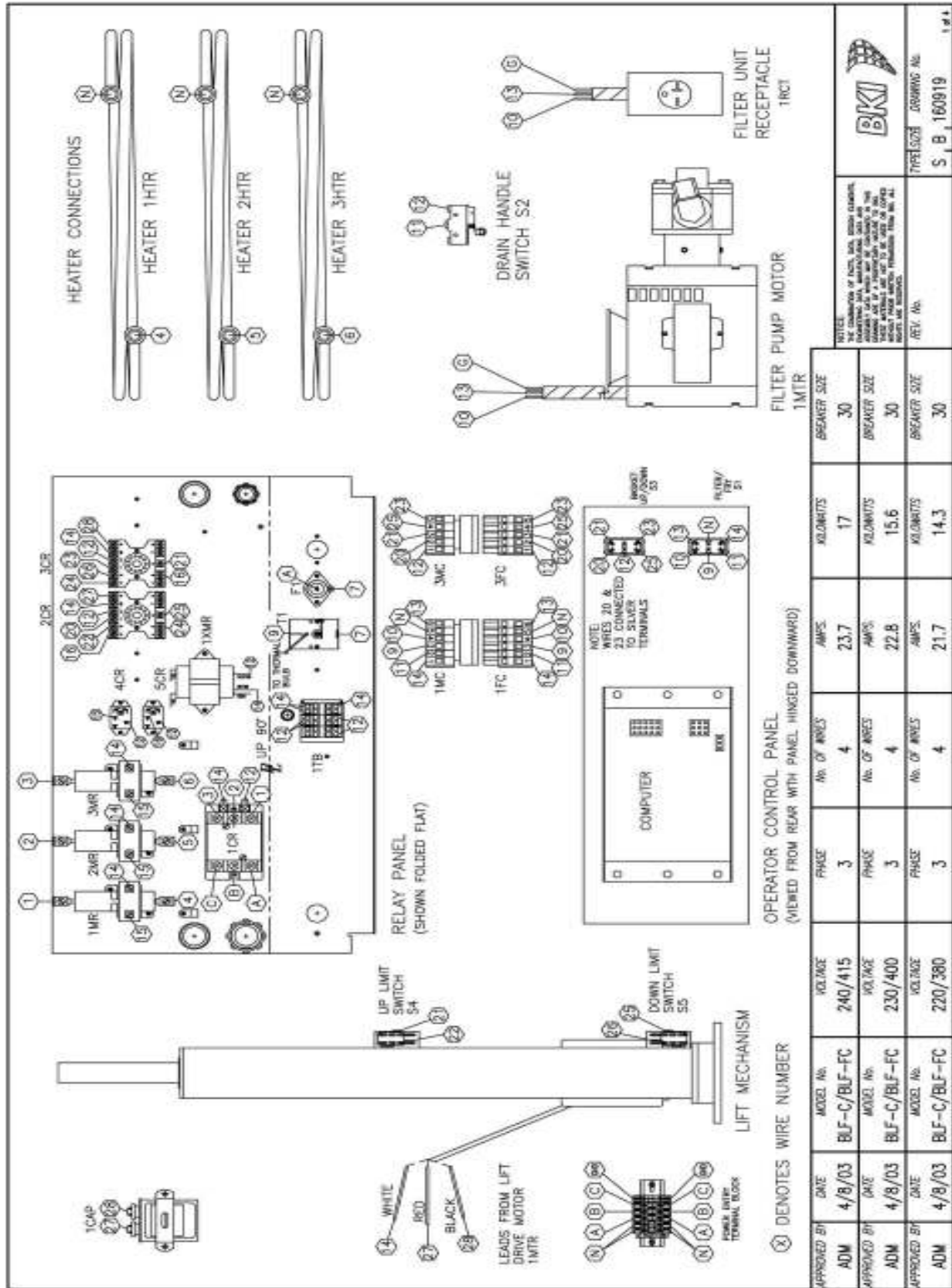
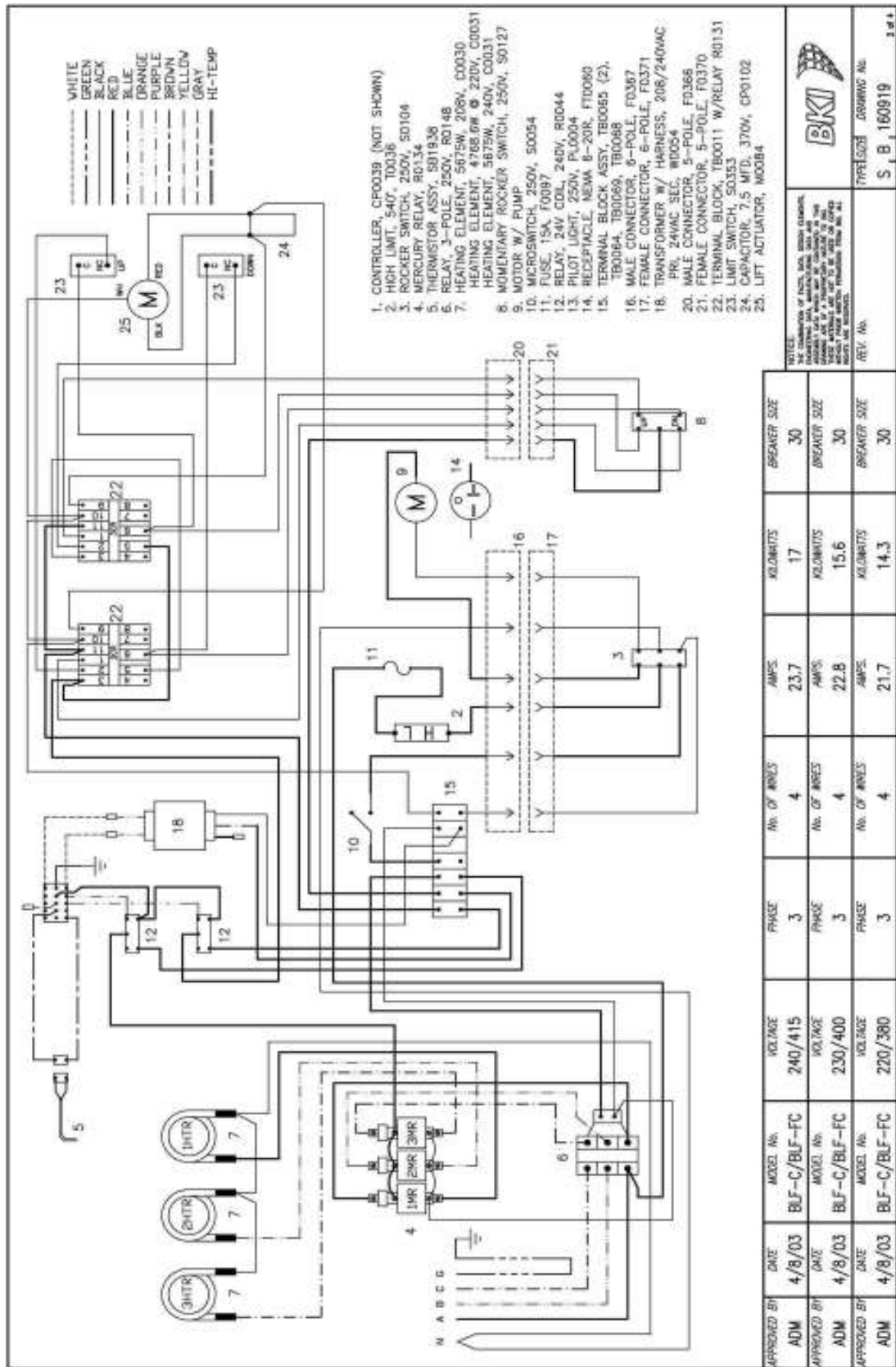

Figure 19. European BLF-FC 220V/380V, 230V/400V, 240V/415V (Sheet 2 of 4)



APPROVED BY	ADM	DATE	4/8/03	MODEL No.	BLF-C/BLF-FC	VOLTAGE	240/415	PHASE	3	No. OF WIRES	4	AMPS.	23.7	KILOAMPS	17	BREAKER SIZE	30
APPROVED BY	ADM	DATE	4/8/03	MODEL No.	BLF-C/BLF-FC	VOLTAGE	230/400	PHASE	3	No. OF WIRES	4	AMPS.	22.8	KILOAMPS	15.6	BREAKER SIZE	30
APPROVED BY	ADM	DATE	4/8/03	MODEL No.	BLF-C/BLF-FC	VOLTAGE	220/380	PHASE	3	No. OF WIRES	4	AMPS.	21.7	KILOAMPS	14.3	BREAKER SIZE	30

Figure 19. European BLF-FC 220V/380V, 230V/400V, 240V/415V (Sheet 3 of 4)

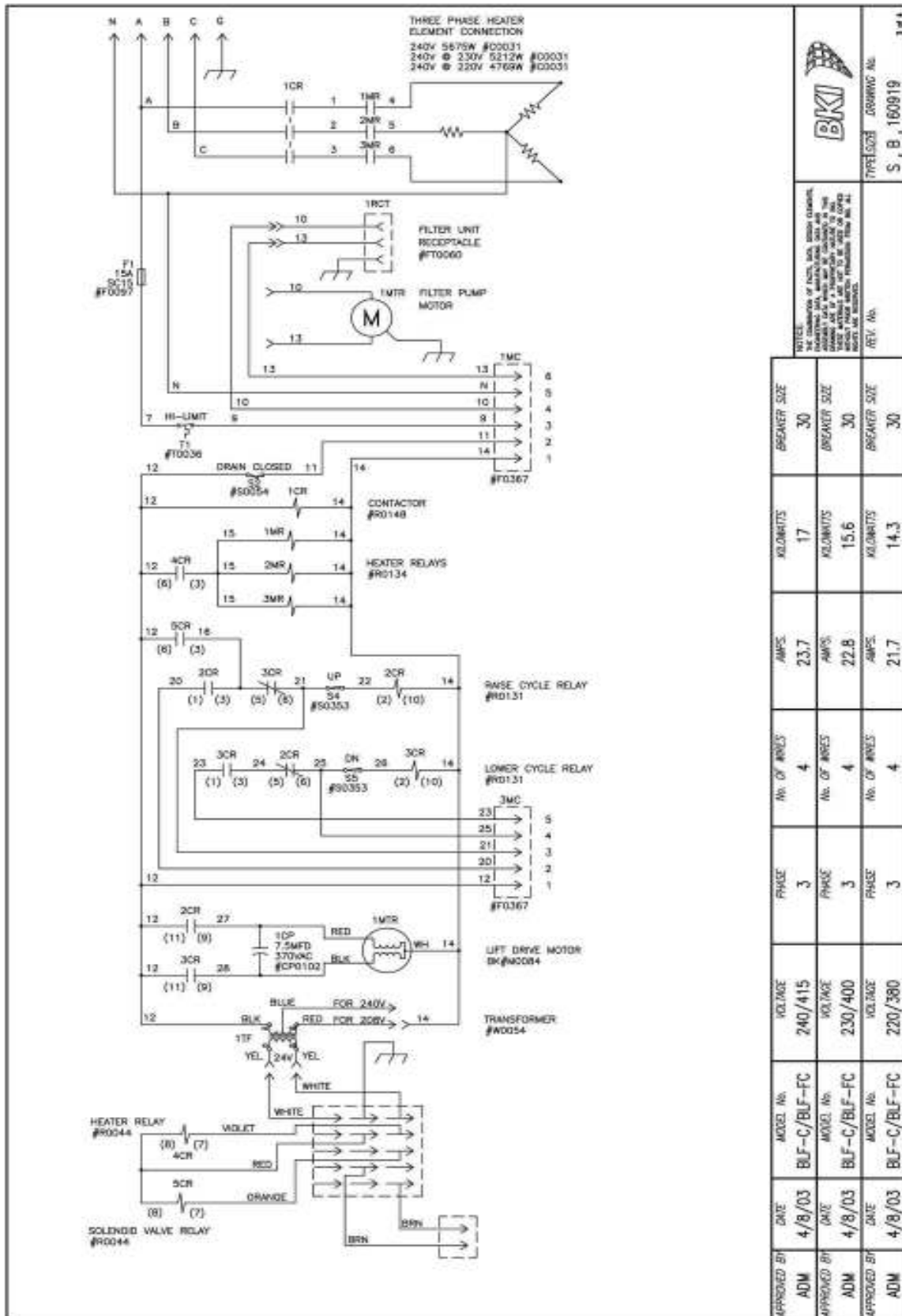
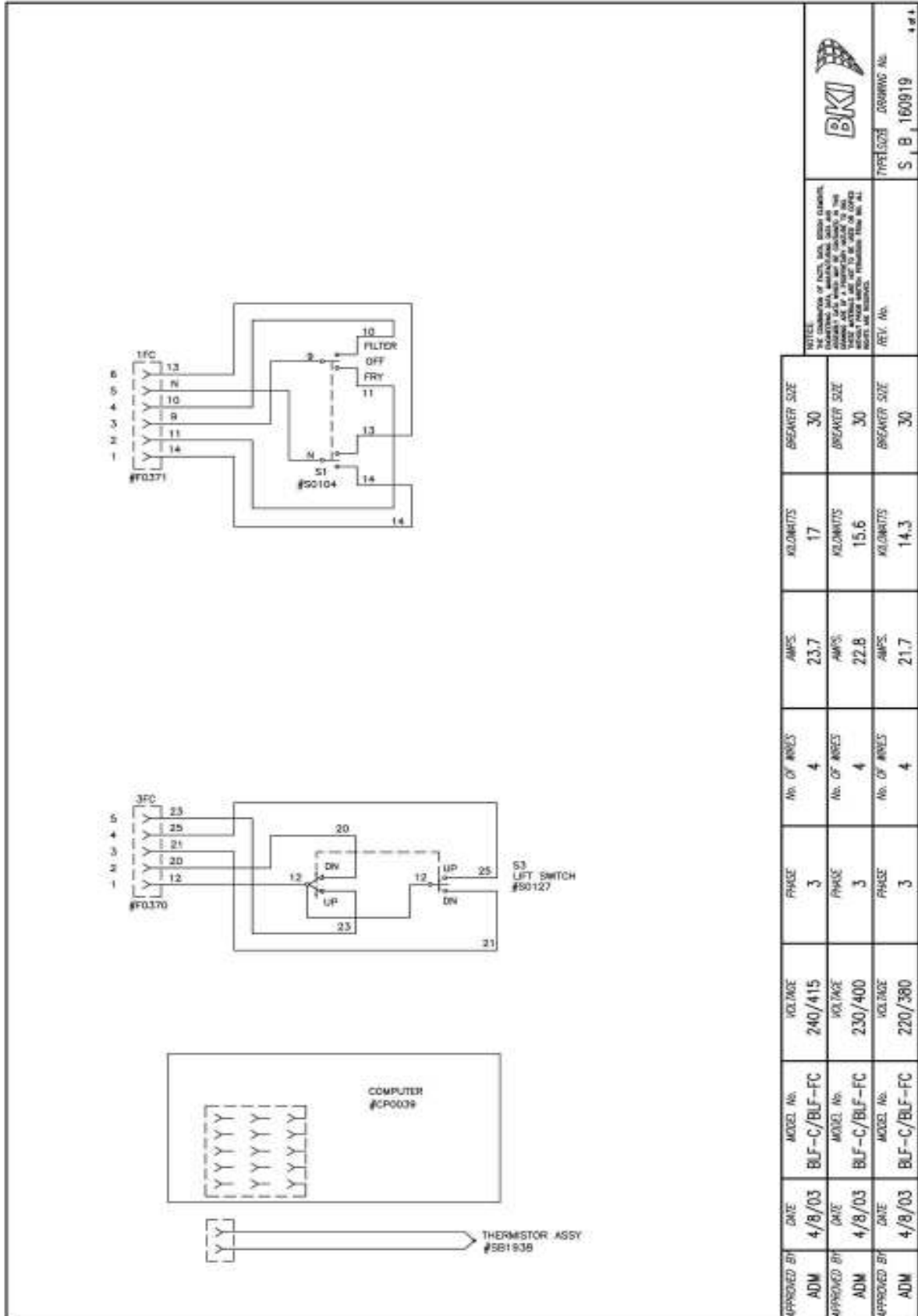

Figure 19. European BLF-FC 220V/380V, 230V/400V, 240V/415V (Sheet 4 of 4)



NOTE:
 THE DIMENSIONS OF PANEL, HOLES, DIMENSIONS, CLAMPING, AND MOUNTING DATA ARE SUBJECT TO CHANGE WITHOUT NOTICE. THE USER SHALL BE RESPONSIBLE FOR VERIFYING THE DIMENSIONS AND MOUNTING DATA OF THE EQUIPMENT BEFORE INSTALLATION. THE USER SHALL BE RESPONSIBLE FOR VERIFYING THE DIMENSIONS AND MOUNTING DATA OF THE EQUIPMENT BEFORE INSTALLATION. THE USER SHALL BE RESPONSIBLE FOR VERIFYING THE DIMENSIONS AND MOUNTING DATA OF THE EQUIPMENT BEFORE INSTALLATION.

APPROVED BY	DATE	MODEL No.	VOLTAGE	PHASE	No. OF WIRES	AMPS.	KILOAMPS	BREAKER SIZE	REV. No.	TYPE/NO.	DRAWING No.
ADM	4/8/03	BLF-C/BLF-FC	240/415	3	4	23.7	17	30			
ADM	4/8/03	BLF-C/BLF-FC	230/400	3	4	22.8	15.6	30			
ADM	4/8/03	BLF-C/BLF-FC	220/380	3	4	21.7	14.3	30			

Notes



2812 Grandview Dr., Simpsonville, S.C. 29680, USA
<http://www.bkideas.com>
Made and printed in the U.S.A
LI0226/0808

REVISION HISTORY

01	1/31/13	KW	LCO 13-003 – remove all references to PO Box 80400; add 2812 Grandview Drive. <i>BKI</i> is no longer using PO Box.
02	2/22/13	KW	Initial Release-Supersedes all previous documents.