

# COMMERCIAL SERIES



# TABLE OF CONTENTS

<b>SECTION 1 - IMPORTANT SAFEGUARDS</b> .....	<b>1</b>
<b>SECTION 2 - UNPACKING</b> .....	<b>3</b>
<b>SECTION 3 - GETTING TO KNOW YOUR BLENDER</b> .....	<b>3</b>
<b>SECTION 4 - INSTALLATION &amp; OPERATIONAL OVERVIEW</b> .....	<b>4</b>
<b>4.1 - STEALTH 875™</b> .....	<b>4</b>
<b>4.2 - CONNOISSEUR 825™</b> .....	<b>16</b>
<b>4.3 - CHEF 775™</b> .....	<b>18</b>
<b>4.4 - EZ 600™</b> .....	<b>20</b>
<b>SECTION 5 - CARE AND CLEANING</b> .....	<b>22</b>
<b>SECTION 6 - TROUBLESHOOTING</b> .....	<b>22</b>
<b>SECTION 7 - WARRANTY</b> .....	<b>26</b>

## SECTION 1: IMPORTANT SAFEGUARDS

### IMPORTANT INFORMATION

Read all instructions carefully before using your Commercial series blender.

Following these instructions will help prevent injuries and damage to the machine and will ensure that you have the best possible experience with your Blendtec® Commercial series blender.

#### 1.1 SAFETY CERTIFICATION

The Commercial series blenders are certified to required safety standards.

This certification ensures that your Commercial series blender has been tested for electrical and mechanical safety. The safety standards have been developed over many years to prevent injury, fire and damage. Part of the certification process includes quarterly audits to ensure that Blendtec is producing equipment to these stringent criteria.

#### 1.2 AVOID CONTACT WITH MOVING PARTS

- ALWAYS keep fingers, hands, hair and clothing away from all moving parts.
- ALWAYS keep all utensils away from the drive socket and blender jar blades during operation as utensils may damage blades or the blender jar.
- NEVER put hands into the blender jar or add substances by hand when the blender jar is on the motor base.
- NEVER touch the blade with your fingers whether it is on or off the motor base.
- NEVER place jar into drive socket if blender motor is operating.
- DO NOT rock or remove the blender jar during operation.

These precautions will prevent personal injury and/or damage to the blender.

#### 1.3 NEVER OPERATE THE BLENDER IF IT APPEARS DAMAGED

If the blender malfunctions, call your service agent first. If it is dropped or damaged in any way, return the blender to a Blendtec service agent immediately for examination, repair, electrical or mechanical adjustment, or possible replacement.

#### 1.4 NEVER OPERATE BLENDER IN LIQUID

To protect against the risk of electrical shock do not put the motor base in water or other liquid. Do not use the blender outdoors where it is subject to precipitation.

#### 1.5 NEVER PUT NON-FOOD ITEMS INTO JAR

Utensils, rocks, and glass are dangerous if placed in jar. Damage caused by such foreign objects will void the warranty. Keep hands and utensils out of jar while blending to reduce the risk of severe injury to persons or damage to the blender. Utensils may only be used when the blender is not running.

#### 1.6 NEVER OPERATE THE BLENDER WITHOUT THE LID IN PLACE

## 1.7 NEVER OPERATE THE BLENDER USING ATTACHMENTS NOT SOLD BY BLENDTEC

The use of any unauthorized attachments may cause fire, electric shock, and/or injury and will void the warranty.

## 1.8 BLENDER JAR MUST BE PROPERLY IN PLACE WHILE APPLIANCE IS OPERATING

## 1.9 USE CAUTION WHEN BLENDING HOT LIQUIDS

Your Commercial series blender may have a vented lid that acts as a pressure relief to allow steam to escape. Be careful not to come in contact with any steam.

## 1.10 POWER CORD PRECAUTIONS

- NEVER operate with a damaged cord or plug. If the supply cord is damaged it must be replaced by the manufacturer or authorized service agent to avoid a hazard.
- DO NOT permit the cord to hang over the edge of the work surface.
- NEVER use an extension cord with the unit.
- Unplug the blender motor when not in use, before changing blender locations, or cleaning.

EACH POWER UNIT MUST BE PROTECTED BY A SEPARATE CIRCUIT BREAKER OR FUSE, SEE MODEL FOR SPECIFICATIONS

## 1.11 NEVER ATTEMPT TO REPAIR THE POWER UNIT

Never remove the blender motor cover. The blender motor does not contain self-adjustable or serviceable parts. A qualified service agent must make all service adjustments. Removing the cover or attempting to service the blender will void the warranty.

## 1.12 TURN THE BLENDER OFF WHEN NOT IN USE

## 1.13 AVOID TOUCHING THE BLENDER DRIVE SOCKET OR JAR SHAFT AFTER USE!

The blender drive socket and jar shaft may become very hot after blend cycles.

## 1.14 SAFETY

This appliance is not intended for use by persons (including children) with lack of experience and knowledge, unless they have been given supervision or instruction concerning use of the appliance by a person responsible for their safety. Children should be supervised to ensure that they do not play with the appliance.

## 1.15 NEVER OPERATE THE BLENDER WITH MORE THAN THE MARKED CAPACITY OF THE JAR

# SECTION 2: UNPACKING

## SAVE ALL PACKAGING MATERIALS AND INSTRUCTIONS FOR FUTURE USE

### 2.1 UNPACKING YOUR BLENDER

You should have received the following items:

- Commercial series blender motor base
- One or more blender jars with lid and sound enclosure\*
- Additional literature may be included depending on package configuration.

Sound enclosure is available only on the Stealth 875™ and Connoisseur 825™ models.

1. Remove blender motor base, blender jar, lids and sound enclosure (if included with model) from packaging.
2. Unwind the power cord.
3. Check for any packing material that may have blocked ventilation holes on the underside of the blender motor base.
4. Inspect all items to ensure no damage occurred during shipment.
5. If any damage has occurred, contact your Blendtec service agent immediately.

### 2.2 RECORDING YOUR SERIAL NUMBER AND DATE OF PURCHASE

Record your blender motor serial number and date of purchase in the space below. You will need these when contacting Blendtec for service or questions.

Motor Serial #(Found on bottom of motor base): \_\_\_\_\_

Date of Purchase: \_\_\_\_\_

Purchased From: \_\_\_\_\_

### 2.3 REGISTERING YOUR BLENDER

Register online at [www.blendtec.com/registration](http://www.blendtec.com/registration)

# SECTION 3: GETTING TO KNOW YOUR BLENDER

## 3.1 BLENDER MOTOR BASE

- Smart Touch Interface: Varying models consist of preprogrammed cycles, incremental speed cycles, timed cycles, a Stop button and a Pulse button.
- Hardened Metal Drive Socket: This is where the jar couples with the motor to turn the blade assembly; made of hardened metal.
- Information Center: This displays the number of times a blend cycle button has been pressed. It also indicates overload or over-temperature conditions.
- Power Unit: This unit is located within the blender motor base and contains the computerized electronics that run the blender.
- Motor Base Cover: Houses the power unit in a durable, plastic material.
- Power Cord: The power cord is located at the back of the motor base cover.

### 3.2 BLENDER JAR ASSEMBLY

The blender jar assembly consists of the blender jar, blade assembly, and lid. These components are integrated to ensure consistently blended drinks and greater operator safety.

- Lid: The lid seals liquids within the jar during blending. Some models have a vent that provides pressure relief when blending hot foods.
- Jar: Your jar is durable, BPA-free, and easy to clean.
- Blade Assembly: The uniquely designed stainless steel blade provides fast, consistent blending.

*NOTE: Never operate the blender with more than the marked capacity of the jar.*

### 3.3 POWER SPECIFICATIONS

Your Commercial series blender is certified for use with a specific circuit voltage, depending on model. Make sure to check your model's power specifications and use a protected circuit when operating your unit.

## SECTION 4: INSTALLATION & OPERATIONAL OVERVIEW

### 4.1 STEALTH 875™

#### 4.1.1 Installation

##### Stealth 875 Above Counter Installation

- Select a location that is near an electrical outlet. Also consider proximity to ingredients, and patrons as well as available counter space.
- Place the blender on the counter in a spot where the air intake vents on the sides and exhaust on the back of the blender are unobstructed.
- Ensure there is enough room above and around the unit to allow for unhampered movement of the sound enclosure (see Figure 1 for measurements).
- Plug the unit into an outlet with appropriate electrical protection.

##### Stealth 875 In-Counter - Preparation for Installation

*Note: You may locate your Blendtec Stealth 875 in the same space as your previous Blendtec in-counter blender. Just remember to ensure proper spacing for the sound enclosure (see Figure 1 for measurements).*

- Identify the desired blender location. Consider proximity to ingredients, and patrons as well as available counter space. Also ensure that an electrical outlet is readily accessible.
- Ensure the location meets all dimensional requirements (see Figures 1 and 3).
- The countertop can be no thicker than 3/4" (19 mm). A thicker countertop will obstruct motor ventilation.

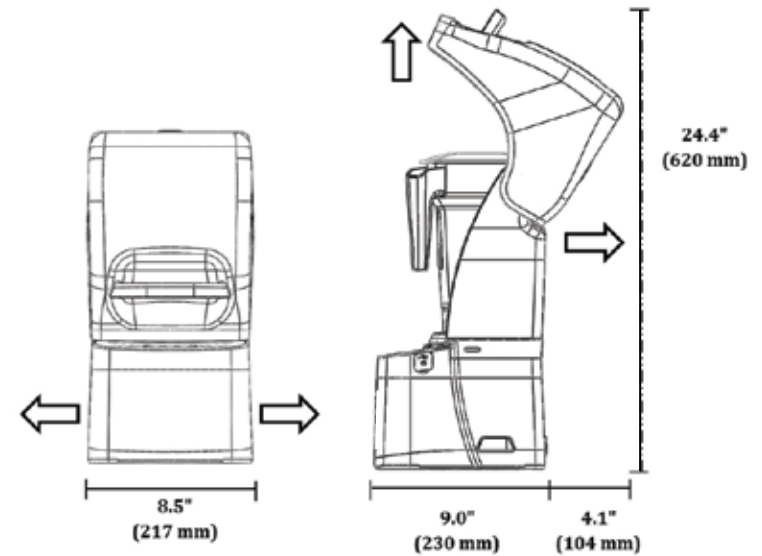

Figure 1. Stealth 875 Dimensions

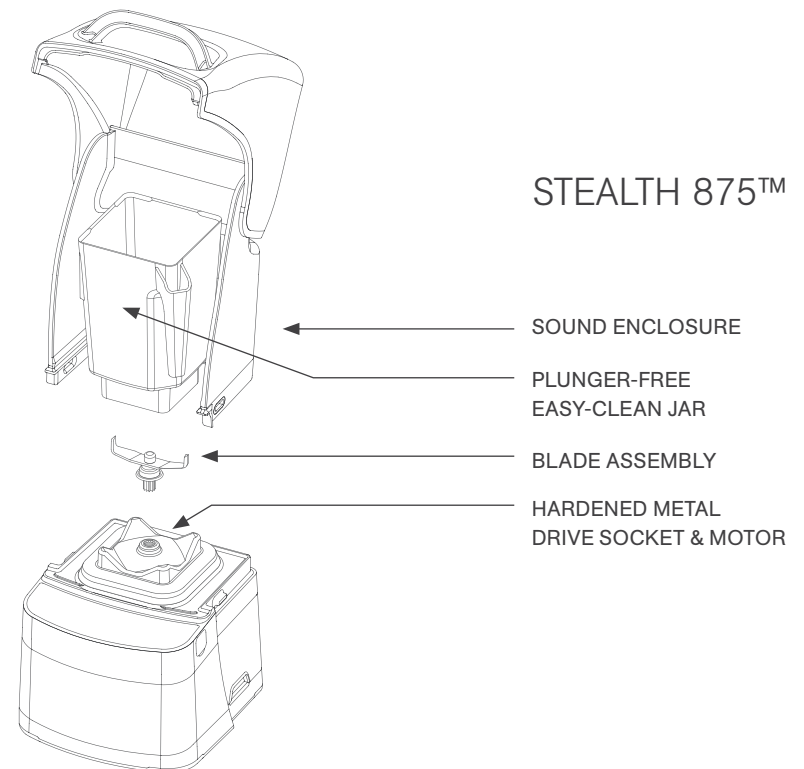

Figure 2. Stealth 875 Components

- If installing more than one blender, allow 14"–16" (356–506 mm) of center-to-center blender spacing.
- If installing a sound enclosure, allow a clearance of at least 5 1/2" (140 mm) from the sound enclosure to the wall and 26" (660 mm) from the countertop to any over-the-counter cabinetry.
- Ensure lower cabinetry allows adequate airflow.
  - The blender draws ambient air into the vent holes located on the upper sides of the motor and then evacuates hot air through the vents on the bottom of the motor. For the motor to cool properly, a sufficient amount of air must be able to circulate around the motor.
  - There should be at least 6 1/2" (165 mm) of space from the countertop to the next lower shelf of the cabinet, leaving a minimum space of 3" (76 mm) between the bottom of the motor and the lower shelf. Cabinetry should not be closed; it should allow air to flow freely from the outside to the inside of the cabinet space. Plastic bags, cups, and so forth, should not be stored closer than 3" (76 mm) from the bottom of the motor.
- Cut a hole in the countertop 4 3/8" (111 mm) wide and 5 7/8" (149 mm) long (see the countertop hole template in the appendix). Ensure that the 4 3/8" (111 mm) sides are parallel with the machine operator.

*Note: Double check to ensure that all space requirements and measurements are correct BEFORE cutting.*

### In-Counter Installation

- Feed the electrical cord through the hole in the countertop.
- Gently place the blender unit into the hole.
- Ensure the gasket is seated correctly, lying flat against the counter surface and not pinched by the housing.
- Plug the unit into an outlet with appropriate electrical protection.

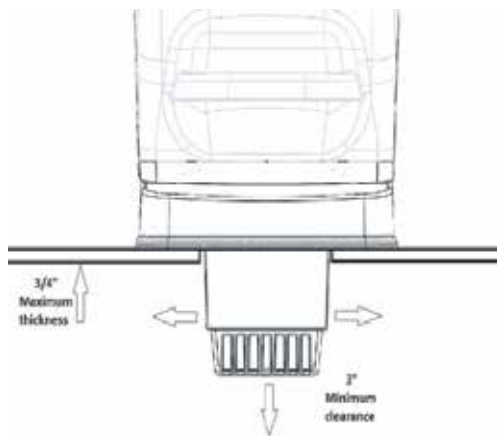
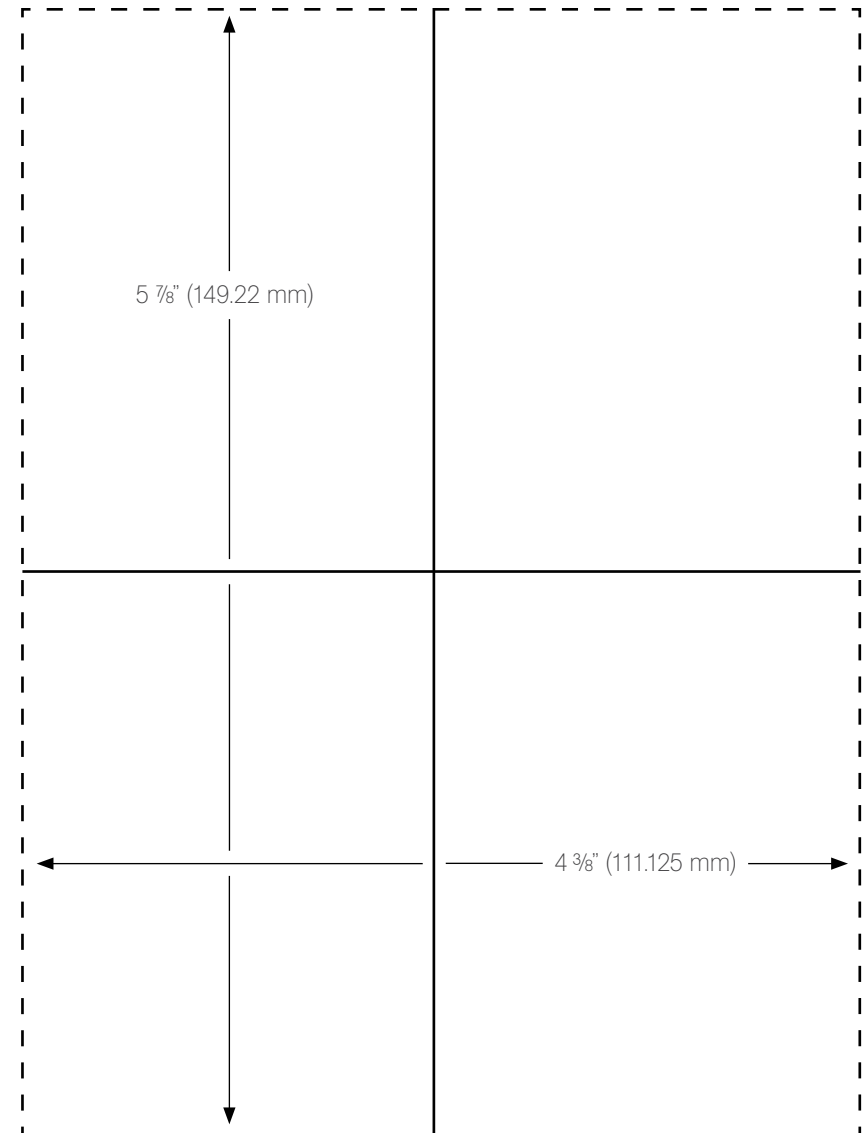

Figure 3. Stealth 875 In-Counter Clearance

### Countertop Hole Template:



### 4.1.2 Quick Start Guide

1. Touch the power icon to turn on the blender.
2. Raise the sound enclosure lid.
3. Place the blender jar on the motor base, ensuring the jar is completely seated and the jar lid is secured.
4. Close the sound enclosure lid.
5. On the control surface, touch the desired blend cycle number, pulse icon or desired location on the slider control bar.
6. Touch the cancel/exit icon to stop a blend cycle or manual operation before the programmed time elapses.

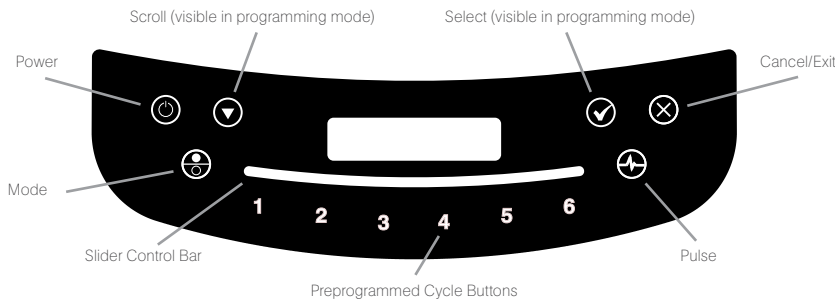

### 4.1.3 Automatic Cycle Operation

Your Stealth 875 blender is preprogrammed with multiple blender profiles to help operators achieve consistent blends with a minimum of training, trial, and error.

You can select from the following profiles and blend cycles:

#### Multipurpose Profile\*

- Button 1: Small Milkshake
- Button 2: Granita/Medium Milkshake
- Button 3: Small Margarita/Ice Cappuccino
- Button 4: Medium Smoothie 4
- Button 5: Large Smoothie 4
- Button 6: 50 Seconds @ Speed 7

\*When you turn the blender on for the first time this will be the default profile.

#### Smoothie Profile

- Button 1: Small Smoothie w/Fresh Fruit
- Button 2: Medium Smoothie 4
- Button 3: Granita/Medium Milkshake
- Button 4: Medium Smoothie 3
- Button 5: Large Smoothie 4
- Button 6: 50 Seconds @ Speed 7

### Coffee Profile

- Button 1: Small Margarita/Ice Cappuccino
- Button 2: Large Ice Cappuccino
- Button 3: Small Slushy/Milkshake
- Button 4: Granita/Medium Milkshake
- Button 5: Large Smoothie 2
- Button 6: 50 Seconds @ Speed 7

### Milkshake Profile

- Button 1: Small Milkshake
- Button 2: Granita/Medium Milkshake
- Button 3: Milkshake w/Frozen Fruit
- Button 4: Large Milkshake 1
- Button 5: Large Milkshake 2
- Button 6: Large Milkshake 3

### 4.1.4 11-Speed Capacitive Touch Slider + Pulse

Touch the mode button to switch from automatic to manual operation mode and the 11-speed capacitive touch slider. The capacitive touch slider provides seamless precision speed control; simply move your finger up and down the slider to fine tune your blender's speed. The blender will run for 90-second intervals in this mode. Select the Pulse function to add a burst of speed and power.

### 4.1.5 Advanced Programming and Diagnostics

Use the programming mode to:

- Select a profile
- Change preprogrammed cycle numbers
- Check blend cycle counts
- Check the diagnostic error log
- Use a custom profile designed via the Blend Wizard™ (Blendtec's online programming tool)

#### To enter programming mode:

1. Touch and hold cancel button for 3 seconds.
2. Use the scroll arrow and the select icon to scroll and select the desired function.

*Note: To return to the main menu from any submenu area, tap the cancel button until the main menu screen appears.*

*The options available from the main menu are listed on the next page (numbered as displayed in the blender):*

## 1. PROFILES

### 1. Standard Profiles

1. Smoothie
2. Coffee
3. Multipurpose
4. Milkshake

### 2. Custom Profiles

## 2. BLEND CYCLES

### 1. Standard Blend Cycles

1. Salsa
2. Batter
3. Whole Juice
4. Soup
5. Ice Cream
6. Small Margarita / Ice Cappuccino
7. Large Ice Cappuccino
8. Ice Crush / Milkshake
9. Small Slushy / Milkshake
10. Small Milkshake
11. Granita / Medium Milkshake
12. Milkshake with Frozen Fruit
13. Large Milkshake 1
14. Large Milkshake 2
15. Large Milkshake 3
16. Small Smoothie with Fresh Fruit
17. Medium Smoothie 1
18. Medium Smoothie 2
19. Medium Smoothie 3
20. Medium Smoothie 4
21. Large Smoothie 1
22. Large Smoothie 2
23. Large Smoothie 3
24. Large Smoothie 4
25. Large Smoothie 5
26. Large Smoothie 6

27. Ultrathick Smoothie 1
28. Ultrathick Smoothie 2
29. Ultrathick Smoothie 3
30. Ultrathick Smoothie 4
31. 50 Seconds @ Speed 1
32. 50 Seconds @ Speed 2
33. 50 Seconds @ Speed 3
34. 50 Seconds @ Speed 5
35. 50 Seconds @ Speed 7
36. 50 Seconds @ Speed 9
37. Pulse @ Speed 1
38. Pulse @ Speed 2
39. Pulse @ Speed 3
40. Pulse @ Speed 5
41. Pulse @ Speed 7
42. Pulse @ Speed 9
43. Disable Button

### 2. Custom Blend Cycles

## 3. CYCLE COUNTS

## 4. DIAGNOSTIC COUNTS

## 5. USB FLASH DRIVE

1. Import Profile
2. Export Active Profile
3. Export Counts

## 6. SETTINGS

1. Enclosure Safety Mode
2. Screen Standby
3. Blend Cycle Pause
4. Slider Lockout
5. Language. There are three language options:
  1. English
  2. French
  3. Spanish

## 7. BLENDER INFO

## 4.16 Selecting the Desired Profile

1. Press and hold the cancel button for 3 seconds.
2. Select Profiles from the menu by touching the select button.
3. Use the scroll and select buttons to select either the Standard Profiles or Custom Profiles category.
4. After selecting the Standard or Customer Profile category, you can scroll through the profiles in the category and select the desired profile.
5. "Make this the active profile?" will appear on the screen. Press the select button to confirm or the cancel button to return to the previous menu.

## 4.1.7 Changing Programmed Cycle Buttons

### Temporarily Change Cycle Buttons

To temporarily change cycle buttons when working in a selected profile, complete the following steps:

1. Press and hold the cancel button for 3 seconds.
2. Use the scroll button and then select Blend Cycles from the menu by touching the select button.
3. Use the select button to choose the Standard or Custom Blend cycles.
4. Use the scroll button to find your desired cycle, then press select.
5. Enter the number you want to assign to the cycle, then press select.

*Note: After you have customized a cycle to a number button, you will notice that an asterisk appears after the profile name when you return to operation mode. Loading a new profile on your blender will reset the profiles back to default cycle buttons.*

### Permanently Change Cycle Buttons

To permanently change the cycle buttons in a profile you can export the revised profile to a USB drive and then import the profile on the blender. Or you can edit the profile using the Blend Wizard ([my.blendtec.com](http://my.blendtec.com)), and then export the profile to the blender.

### Temporarily Disable Cycle Buttons

To temporarily disable a number or cycle button when working in a selected profile, complete the following steps:

1. Press and hold the cancel button for 3 seconds.
2. Use the scroll button and then select Blend Cycles from the menu by touching the select button.
3. Use the select button to choose the Standard Blend Cycles.
4. Use the scroll button to find Disable Button, then press select.
5. Enter the number button you want to disable, then press select.

*Note: After you have disabled a number button, you will notice that an asterisk appears after the profile name when you return to operation mode. The disabled button will also not appear on control panel.*

*Loading a new profile on your blender will reset the profiles and enable all the cycle buttons again.*

## Permanently Disable Cycle Buttons

To permanently change the cycle buttons in a profile you can export the revised profile to a USB drive, and then import the profile on the blender. Or you can disable any number using the Blend Wizard (my.blendtec.com), and then export the revised profile to the blender.

### 4.1.8 The Blend Wizard

In addition to using the profiles and cycles preprogrammed on your blender, you can use the Blend Wizard to create custom profiles and cycles. For instructions on using the Blend Wizard to easily develop custom profiles and cycles, visit my.blendtec.com.

#### Importing Custom Profiles and Cycles

After you've created your custom profiles and cycles using Blend Wizard and downloaded them to a USB flash drive, use the follow steps to import the file to your blender.

1. Use a Phillips screwdriver to remove the USB cover at the top of the right side of the blender.
2. Plug the USB flash drive into the blender's USB port.  
*Note: If the blender is in manual or automatic operation mode, the USB flash drive menu will automatically load on the screen. If the blender is in programming mode, go to the main menu and select USB Flash Drive.*
3. Select Import Profile from the USB flash drive menu.
4. Scroll through the items on the flash drive and locate the desired custom profile file (by default named stealth.bpf).  
*Note: Items with a + sign next to them are folders; if the custom profile file is in a folder, press the select button to open the folder.*
5. Select the desired file. You will then be asked whether you want to import the selected file.
6. Press the select button again to start the import process. After the file has been imported, the profile in the file will be automatically loaded as the active profile on the blender.
7. Remove the USB drive from the blender, and secure the cover on the USB port with a Phillips screwdriver.

#### Secure Blender Feature

When creating or modifying a profile via the Blend Wizard, one of the options is to secure the blender. If you select this option, once you have downloaded the profile to a USB drive and then imported the profile to the blender, some of the advanced programming functions will be disabled.

The secured profile will be the active profile on the blender, another profile cannot be made the active profile and a new profile cannot be imported to the blender (unless it was created via your Blend Wizard account). Additionally, the blend cycles in the profile cannot be changed on the blender, and the Enclosure Safety Mode, Screen Standby Time, Blend Cycle Pause and Slider Lockout settings cannot be modified.

To unlock these features, complete the following steps:

1. Log on to your Blend Wizard account at my.blendtec.com.
2. Edit the secured profile, selecting the option to turn off the secure blender mode, or create a new profile with the secure blender mode turned off.
3. Import the profile to a USB drive, and then follow the instructions to import the file to the blender.

#### Exporting and Transferring Profiles

To export profiles and transfer them to the Blend Wizard, complete the following steps:

1. Ensure the profile you want to export is the active profile on the blender.
2. Use a Phillips screwdriver to remove the USB cover at the top of the right side of the blender.
3. Plug the USB flash drive into the blender's USB port.  
*Note: If the blender is in manual or automatic operation mode, the USB flash drive menu will automatically load on the screen. If the blender is in programming mode, go to the main menu and select USB Flash Drive.*
4. Use the scroll button to find Export Active Profile and press the select button.  
*Note: If the USB flash drive the file is being exported to does not already contain the sth-prof.bpf file, the LED screen will display the question, "Export profile to the sth-prof.bpf file?" Press the select button to start the export process. Press the cancel button to return to the previous menu.*  
*If the USB flash drive the file is being exported to already contains the sth-prof.bpf file, the LED screen will display the question, "Export profile and overwrite the sth-prof.bpf file?" If you want to overwrite the file on the USB flash drive, press the select button to start the export process. If you do not want to overwrite the file on the USB flash drive, press the cancel button to cancel the export.*
5. After the export is complete, remove the USB flash drive and secure the cover on the USB port with a Phillips screwdriver.
6. Insert the USB flash drive into a computer, and log in to the Blend Wizard (my.blendtec.com). Follow the instructions on the site to transfer the profile to your account.

### 4.1.9 Blender Settings

You can change various blender settings for optimal blending performance and function based on your needs.

#### Enclosure Safety Mode

The enclosure safety feature prompts you to ensure the sound enclosure lid is closed during motor operation. It will also turn off the motor if you raise the sound enclosure during blending.

To enable or disable the enclosure safety feature, complete the following steps:

1. Press and hold the cancel button for 3 seconds.
2. Use the scroll button and then select Settings from the menu by touching the select button.
3. Use the select button to choose the Enclosure Safety Mode.

4. Use the scroll button to toggle between disabling and enabling the enclosure safety feature.
5. Press the cancel button to return to the previous menu.

### Screen Standby Time

You can adjust the length of time before the blender switches to standby mode (15 minutes, 1 hour, 6 hours or 12 hours).

To select a new standby time, complete the following steps:

1. Press and hold the cancel button for 3 seconds.
2. Use the scroll button and then select Settings from the menu by touching the select button.
3. Use the select button to choose the Screen Standby.
4. Use the scroll button to find your desired standby time, then press select.
5. Press the cancel button to return to the previous menu.

### Blend Cycle Pause

When in automatic mode, this setting allows you to pause and resume a blend cycle at the same time and speed.

To enable or disable the Blend Cycle Pause feature, complete the following steps:

1. Press and hold the cancel button for 3 seconds.
2. Use the scroll button and then select Settings from the menu by touching the select button.
3. Use the select button to choose the Blend Cycle Pause.
4. Use the scroll button to toggle between disabling and enabling, the blend cycle pause.

*Note: When the Blend Cycle Pause is disabled, a cycle cannot be paused. It can only be stopped by pressing the cancel button.*

5. Press the cancel button to return to the previous menu.

### Slider Lockout

The Slider Lockout feature allows you to disable the slider bar on the control surface. When this feature is enabled, only profiles on the blender can be used to operate the blender.

To enable or disable this feature, complete the following steps:

1. Press and hold the cancel button for 3 seconds.
2. Use the scroll button and then select Settings from the menu by touching the select button.
3. Use the select button to choose the Slider Lockout.
4. Use the scroll button to toggle between disabling and enabling, the slider lockout.
5. Press the cancel button to return to the previous menu.
6. Language. There are three language options:
  - English
  - French
  - Spanish

## 4.1.10 Blender Statistics

### Blend Cycle Counts

You can review the total number of cycles run, the number of cycles run for each control surface number, the number of times the pulse button has been used and the number of times the slider control bar has been used.

1. Press and hold the cancel button for 3 seconds.
2. Use the scroll button and then select Cycle Counts from the menu by touching the select button.
3. Use the scroll button to see the number of cycles run in each category.
4. Press the cancel button to return to the previous menu.

*Note: The pulse count refers to pulse sets. For example, touching the pulse button 5 times in a row will register as 1 pulse count. Touching the pulse button, then a cycle number and then the pulse button will register as 2 pulse counts.*

### Diagnostic Error Log

You can review the diagnostic errors that have been logged on the blender.

1. Press and hold the cancel button for 3 seconds.
2. Use the scroll button and then select Diagnostic Counts from the menu by touching the select button.
3. Use the scroll button to see the how many errors have occurred in each category.
4. Press the cancel button to return to the previous menu.

### Exporting Blender Statistics

Exporting blender statistics (cycle counts, errors, settings and firmware versions) is a way to save diagnostic information, which Blendtec's customer service and repair experts will use if problems arise with your blender.

To export blender statistics to a USB drive, complete the following steps:

1. Use a Phillips screwdriver to remove the USB cover at the top of the right side of the blender.

2. Plug the USB flash drive into the blender's USB port.

*Note: If the blender is in manual or automatic operation mode, the USB flash drive menu will automatically load on the screen. If the blender is in programming mode, go to the main menu and select USB Flash Drive.*

3. Use the scroll button to find Export Counts, then press the select button. You will be asked if you want to export counts to the sth-cnts.csv file.
4. Press the select button again to start the export process.
5. After the export process is finished, remove the USB drive from the blender and secure the cover on the USB port with a Phillips screwdriver.

## 4.2 CONNOISSEUR 825™

### Quick Start Guide

1. Turn on the blender by toggling the power switch on the front of the blender.
2. Raise the sound enclosure lid.
3. Place the blender jar on the motor base, ensuring the jar is completely seated and the jar lid is secured.
4. Close the sound enclosure lid.
5. On the touchpad, press the desired blend cycle number or pulse icon.
6. Push any blend cycle button to stop a blend cycle before the programmed time elapses.



### Automatic Cycle Operation

Your Connoisseur blender is preprogrammed with multiple blender profiles, to help operators achieve consistent blends with a minimum of training, trial and error.

You can select from the following profiles and blend cycles:

#### Multipurpose Profile\*

- Button 1: Small Milkshake
- Button 2: Granita/Medium Milkshake
- Button 3: Small Margarita/Ice Cappuccino
- Button 4: Medium Smoothie 4
- Button 5: Large Smoothie 4
- Button 6: Pulse

\*When you turn the blender on for the first time this will be the default profile.

### Preprogrammed Cycles

For a complete list of preprogrammed profiles or cycles and instructions on how to program and change profiles or cycles, please visit [blendtec.com](http://blendtec.com)

### Pulse Function

The Pulse button is used for chopping, mincing, whipping or other momentary tasks that do not require a long blend cycle. You can also use the Pulse button to quickly stir a blend before serving.

The Pulse setting runs at speed 7 and will only run while the Pulse button is held down. When the button is released, the motor shuts off.

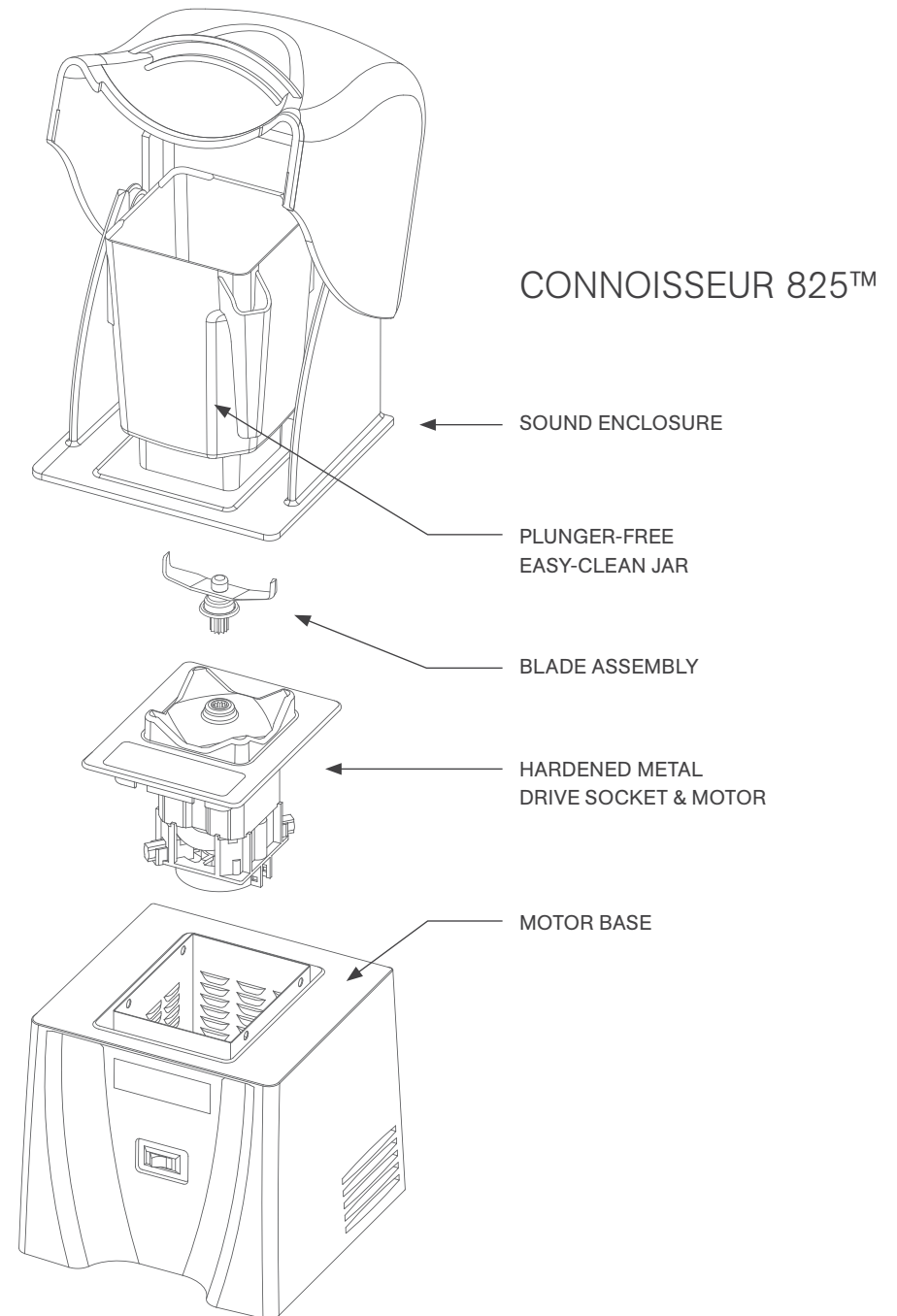

## 4.3 CHEF 775™

### Quick Start Guide

1. Touch the power icon to turn on the blender.
2. Place the blender jar on the motor base, ensuring the jar is completely seated and the jar lid is secured.
3. On the control surface, touch the desired blend cycle icon, pulse icon or desired location on the slider control bar.
4. Touch the cancel/exit icon to stop a blend cycle or manual operation before the programmed time elapses.

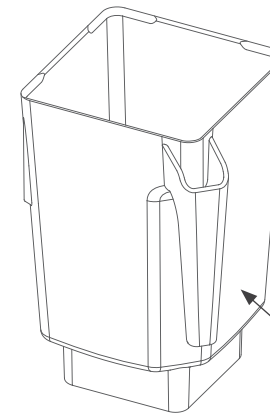
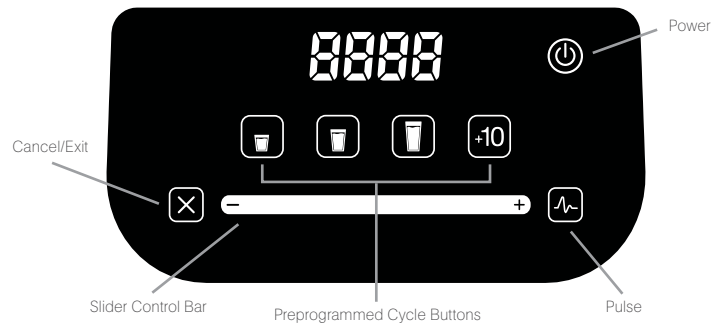

CHEF 775™

PLUNGER-FREE  
EASY-CLEAN JAR

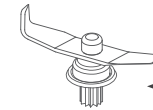

BLADE ASSEMBLY

### One-Touch Controls

Operating the Chef 775 couldn't be easier. Presets for Small, Medium and Large beverages make it easy for anyone to operate with little training. Each setting shuts off automatically, and a Pulse button provides a quick burst of needed speed and power.

### 8-Speed Capacitive Touch Slider + Pulse

The capacitive touch slider provides seamless precision speed control; simply move your finger up and down the slider to fine-tune your blender's speed. The Pulse function adds a burst of speed and power.

### “Add 10” Function

The “Add 10” icon allows users to add 10-second intervals to blend cycles, providing completely customized blends. It also acts as a stand-alone 10-second cycle.

### Chef Series Profile Configuration

Changing profile configurations on the Chef Series blenders can be done within the first 10 seconds after the blender is plugged in. The blender profile is configured by holding a specific combination of 3 buttons (shown below) for 2.5 seconds within the 10 second window after plugging in and powering on the blender into ready mode.

Coffee Profile.....Stop, Small, Medium  
Smoothie Profile (default).....Stop, Medium, Large  
Milkshake Profile .....Stop, Large, +10

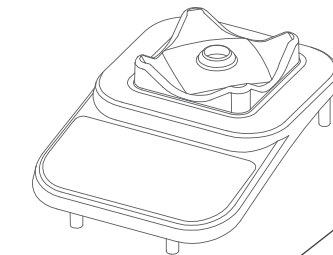

TOP COVER & TOUCH PAD

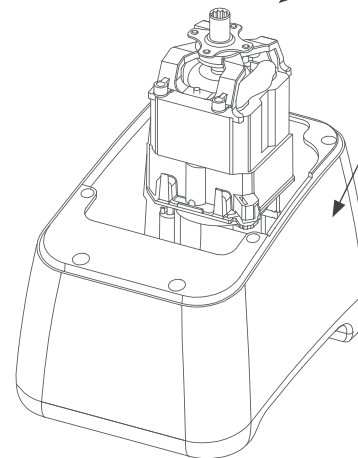

HARDENED METAL  
DRIVE SOCKET & MOTOR

MOTOR BASE

Once configured, the profile will be displayed for 1 second before returning to ready mode.

- COFF = Coffee
- SNOO = Smoothie
- NSHA = Milkshake

## 4.4 EZ 600™

### Quick Start Guide

1. Toggle the power switch on the back of the motor base.
2. Place the blender jar on the motor base, ensuring the jar is completely seated and the jar lid is secured.
3. On the control surface, touch the desired blend cycle icon or pulse icon.
4. Push any blend cycle button to stop a blend cycle before the programmed time elapses.



### Blender Modes

The EZ 600 includes three profiles that can be changed when first turning on the blender. In order to change between modes:

1. Turn on the blender.
2. Within 10 seconds of the blender being in idle mode (where it displays cycle count) enter the code for the desired mode:
  - a. Coffee- Press and release Small, then Medium, then Large.
  - b. Smoothie- Press and release Medium, then Large, then Pulse.
  - c. Milkshake- Press and release Large, then Pulse, then Small.
3. When the code is entered successfully, the blender will store the new mode, and then return to the idle screen.

### Pulse Function

The Pulse button is used for chopping, mincing, whipping or other momentary tasks that do not require a long blend cycle. You can also use the Pulse button to quickly stir a blend before serving.

The Pulse setting runs at speed 7 and will only run while the Pulse button is held down. When the button is released, the motor shuts off.

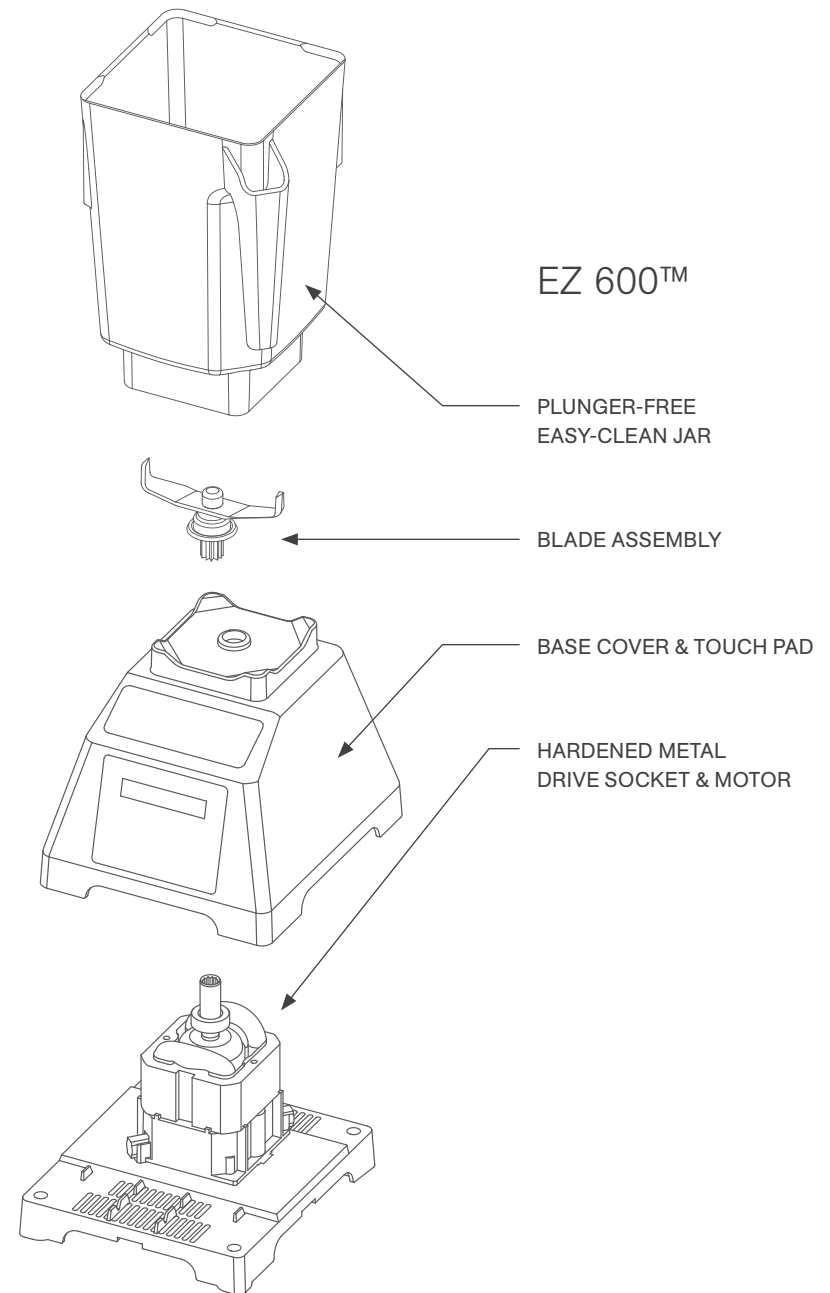

## SECTION 5: CARE AND CLEANING

### 5.1 CLEANING AFTER USE

1. Add hot water and 1-2 drops of liquid dish soap to the blender jar.
2. Place the lid tightly onto the jar, place the jar on the motor base and press and hold the pulse button for 5-10 seconds.
3. Rinse all soap from the jar and lid with water.
4. If the jar is stored upside down, shake excess water from the jar after cleaning.

*Note: WildSide+™ and FourSide™ jars can be stacked to save space.*

### 5.2 LONG-TERM SANITATION

1. Sanitize the jar per local code by filling the blender jar with a sanitizer diluted to the manufacturer's specifications. Bleach, properly diluted, can be used.
2. Leave the diluted sanitizer in the jar for 5 minutes.
3. Empty the sanitizer from the jar.
4. Rinse jar thoroughly with water.
5. If the jar is stored upside down, shake excess water from the jar after cleaning.

### 5.3 MOTOR BASE AND SOUND ENCLOSURE CLEANING

- Ensure the blender is unplugged before cleaning.
- Wipe down the plastic housing of the motor base, gaskets, metal top and sound enclosure with a clean, damp rag. A mild, all-purpose, nonabrasive cleaner may be used.
- The drive socket can be cleaned using a cotton swab or toothpick.
- For Stealth blender models, the sound enclosure can also be removed for cleaning, when necessary.
  - Open the sound enclosure lid and use both hands to pull outward on the lid at the pivot joints. This step will flex the plastic enough for it to spread and clear its mounting tabs.
  - The sound enclosure base can be removed in a similar fashion by pulling outward at the base of the sound enclosure and flexing the outer walls enough to clear the mounting tabs.

### 5.4 CLEANING TIPS AND CAUTIONS

- Do not use stiff bristled brushes or abrasive cloths/pads to clean the blender base, jar or sound enclosure as this will dull or scratch the surface.
- Do not use a water jet of any kind to clean the motor base.
- NEVER submerge the motor base in water. Doing so will void the warranty.
- Avoid submerging blender jars for more than 5 minutes. Water penetration through the lower jar seals will reduce the life of the jar.

## SECTION 6: TROUBLESHOOTING

While we don't expect you to have any problems with your blender, sometimes failures do occur. Use the following guidelines to see if the problem is easily fixed or requires service.

### 6.1 BLENDER MOTOR WILL NOT TURN ON (NO POWER)

If the blender motor will not turn on, try the following:

- For the Stealth 875 and Chef 775 look to see if the control surface has an illuminated power icon, for the Connoisseur 825 and EZ 600 determine if the Liquid Crystal Display (LCD) is lit. Absence of those indicators indicates a lack of power to the unit.
- Check your house circuit breaker switch or fuse to make sure it is set to the ON position.
- Unplug the power cord from the wall receptacle, wait 5 seconds, then plug power cord back in.

### 6.2 ERROR MESSAGES ON DISPLAY

#### STEALTH 875™

**Touch Error** — This indicates that more than one touch sensor on the blender has been touched. To avoid this message, touch the center of the desired button. If this icon remains on when no one is touching the touch area, unplug and re-plug in the blender. If the problem persists please contact your Blendtec Service Agent.

**Overtemp Error** — This indicates that the motor is overheating. The blender has been disabled until the unit cools to operating temperatures. If the blender does not work after 20 minutes or more of cooling time, please call your Blendtec Service Agent.

**Overload Error** — This indicates an overload on the motor.

1. Clear the error message by pressing any button or turning the blender off and on again.
2. Remove the jar, and run the blender to determine whether the issue relates to the jar or the motor.
3. With the jar removed, check for blockage in or around the socket on the motor base and the blade assembly on the jar.
4. Place the jar securely on the motor base, and touch to pulse the blade through the mixture.
5. Ensure the jar is not loaded with excessively hard or thick ingredients.

If overload condition re-occurs, contact your Blendtec service agent.

**Reset Errors** — If the following error messages appear, reset the error by pressing the cancel button or cycle the power by unplugging your blender and then plugging it back in. If the error does not clear, contact your Blendtec service agent.

- Error: Overtemp. condition detected
- Error: Overload condition detected
- Error: Temp. sensor not detected
- Error: Zero crossing not detected
- Error: Reset error detected
- Error: Read/Write error detected
- Error: Motor control error detected
- Error: Invalid blend cycle
- Error: Touch controller not detected
- Error: Touch controller output is invalid

## CONNOISSEUR 825™

Overtemp Error — This indicates that the motor is overheating. The blender has been disabled until the unit cools to operating temperatures. If the blender does not work after 20 minutes or more of cooling time, please call your Blendtec Service Agent.

Overload Error — This indicates an overload on the motor.

1. Clear the error message by pressing any button or turning the blender off and on again.
2. Remove the jar, and run the blender to determine whether the issue relates to the jar or the motor.
3. With the jar removed, check for blockage in or around the socket on the motor base and the blade assembly on the jar.
4. Place the jar securely on the motor base, and touch to pulse the blade through the mixture.
5. Ensure the jar is not loaded with excessively hard or thick ingredients.

If overload condition re-occurs, contact your Blendtec service agent.

A “Watchdog Timeout” error indicates a disruption in the normal operation of the electronic blender controls. This is an uncommon error message, which is usually caused by incoming power fluctuations or spikes. This error message is cleared by turning off the blender for ten seconds (using the switch), then turning back on. If this error is displayed immediately on start-up, or if it occurs regularly during normal use contact your Blendtec service center for assistance.

## CHEF 775™



Overtemp Error — This indicates that the motor is overheating. The blender has been disabled until the unit cools to operating temperatures. If the icon does not disappear after 20 minutes or more of cooling time, please call your Blendtec Service Agent.



Touch Error — This indicates that more than one touch sensor on the blender has been touched. To avoid this message, touch the center of the desired button. If this icon remains on when no one is touching the touch area, unplug and re-plug in the blender. If the problem persists please contact your Blendtec Service Agent.



Overload Error — This indicates an overload on the motor.

1. Clear the error message by pressing any button or turning the blender off and on again.
2. Remove the jar, and run the blender to determine whether the issue relates to the jar or the motor.
3. With the jar removed, check for blockage in or around the socket on the motor base and the blade assembly on the jar.
4. Place the jar securely on the motor base, and touch to pulse the blade through the mixture.
5. Ensure the jar is not loaded with excessively hard or thick ingredients.

If overload condition re-occurs, contact your Blendtec service agent.



Reset Errors — If this message appears on the LED information center it indicates there has been an error. There are error messages from E-01 through E-06. If any of these errors appear, press the stop button to clear the message. If the error message reappears please contact your Blendtec Service Agent.

## EZ 600™

Overtemp Error — This indicates that the motor is overheating. The blender has been disabled until the unit cools to operating temperatures. If the blender does not work after 20 minutes or more of cooling time, please call your Blendtec Service Agent.

Overload Error — This indicates an overload on the motor.

1. Clear the error message by pressing any button or turning the blender off and on again.
2. Remove the jar, and run the blender to determine whether the issue relates to the jar or the motor.
3. With the jar removed, check for blockage in or around the socket on the motor base and the blade assembly on the jar.
4. Place the jar securely on the motor base, and touch to pulse the blade through the mixture.
5. Ensure the jar is not loaded with excessively hard or thick ingredients.

If overload condition re-occurs, contact your Blendtec service agent.

## 6.3 NOISE LEVEL CHANGES

If the blender noise level has increased from original levels, determine whether the sound is coming from the blender motor or jar.

1. Blender Motor: Remove the jar from the motor base and run the motor. If it is excessively noisy, contact your Blendtec service center for evaluation.
2. Jar: After checking the motor, place the jar back on the motor with about 16 oz (475 mL) of water. Run the motor for a few seconds using the pulse button. (If you have more than one jar, test a different jar to determine whether the sound is different.) If a jar is excessively noisy or if the blade assembly seems loose or sounds “gravelly” when turned by hand, contact your Blendtec service center.

## 6.4 NOT BLENDING OR UNSATISFACTORY BLENDED TEXTURE

If your blender has stopped blending or if the blended texture of product is lumpy or uneven, do the following:

1. Ensure the mixture is not cavitating during the cycle. Cavitation is a condition in which an air pocket forms within the drink mix because the mix is too cold or too solid. The blender blade then spins freely in this cavity. This problem can be corrected by increasing the mix temperature by either reducing ice, increasing liquid and/or ensuring that the frozen ingredients used in the recipe are never colder than 10 degrees Fahrenheit (-12 degrees Celsius).
2. If the drink is mixing well but has not had enough time for complete blending, increase cycle time. Try a longer cycle or touch and hold the “Pulse” button for the required extra blending time.
3. Make sure the jar is fully seated on the blender base.
4. Check if the blade is firmly affixed to the drive shaft. Hold the drive shaft in one hand and try to spin the blade with the other hand. If the blade turns without turning the drive shaft, contact your Blendtec customer service agent.
5. TRIED EVERYTHING? If none of the preceding suggestions work, contact your Blendtec service agent for further assistance.

## 6.5 UNRESPONSIVE CONTROL SURFACE

If the control surface of your blender is not responding, wipe it down with a damp rag to remove any liquids or particle buildup. If that doesn't work, unplug the power cord and then plug it in again.

**INSTRUCTIONS THAT APPEAR IN THIS USER GUIDE ARE NOT MEANT TO COVER EVERY POSSIBLE CONDITION OR SITUATION THAT MAY OCCUR. GOOD JUDGMENT MUST BE USED WHEN OPERATING THIS OR ANY OTHER MACHINERY.**

## SECTION 7: WARRANTY

### 7.1 WARRANTY DESCRIPTION

Blendtec warrants the your blender against defects in materials and workmanship under normal use, maintenance and service, for 1-3 years\* on parts and labor required to repair or replace components that, in the sole opinion of Blendtec, are defective. The following items are not included the blender warranty coverage:

- Normal maintenance, adjustments and cleaning as outlined in this manual.
- Repairs due to unauthorized service or modifications to the blender, product tampering or use of non-standard parts or accessories without prior written approval from Blendtec.
- Damage cause by: improper installation or ventilation of the blender; electrical supply (e.g., electrical power failure, improper electrical connections, the use of extension cords, low voltage or voltage drops to the unit); water supply; drainage; exposure to water; or floods, storms or other acts of God.
- Cost of premium labor rates due to holidays, overtime, shipping, etc.
- Parts or assemblies subjected to misuse, abuse, neglect or accidents or lack of specified maintenance or operational procedures.
- Damage or problems caused by installation, relocation of unit, cleaning and/or maintenance procedures inconsistent with the technical instructions provided in this manual.
- Claims for personal injuries, incidental or consequential damages or economic loss (profit or revenue), however caused.

\*Warranty periods vary according to blender model.

#### 7.1.1 Water Damage and Abuse

It is critical to prevent liquids from entering the motor base. The motor base has been designed to deflect liquids from entering. However, in some instances of heavy spillage or a lack of appropriate cleaning procedures, liquids may enter the motor housing. It is important to promptly clean up all spills on the motor, around the counter and under the sound enclosure base (if used). Failure to do so may result in liquids being pulled into the motor, which will lead to premature failure. This cause of failure is considered abuse and is not covered under the warranty.

#### 7.1.2 Country of Purchase

Warranty is provided only in the country in which the equipment was purchased from an authorized sales representative. Use of the equipment outside the country of purchase voids all warranties, expressed or implied. If a customer chooses to utilize a local service center outside of the country of original sale, he or she can reasonably expect to pay for parts, labor, shipping, duties, taxes, etc., necessary to make the repair and return the equipment.

#### 7.1.3 Service Procedure

If you experience any difficulty in using your Blendtec blender and following the troubleshooting steps in Section 7 does not resolve the problem, immediately contact Blendtec customer service at 1-800-BLENDTEC (US customers) or a Blendtec qualified service agent (international customers) to diagnose the problem. Please have your blender's serial number ready and be prepared to describe the problem. Do not attempt to do your own repairs. The warranty will be voided if repairs are made by individuals other than Blendtec qualified service agents. Many issues can be resolved simply and quickly over the phone. If the problem cannot be resolved over the phone, your unit may require replacement.

**If your machine is under warranty**, Blendtec will repair or replace the blender at no cost. Cosmetic damage and abuse are not included.

**If your machine is out of warranty** and you wish to have it repaired, contact Blendtec customer service at 1-800-BLENDTEC (US customers) or a Blendtec qualified service agent (international customers) for instructions. You will be billed for services rendered.

When shipping your blender to Blendtec customer service or a qualified service agent (either in warranty or out of warranty), please include the form on the following page.

**THIS WARRANTY IS IN LIEU OF ALL OTHER WARRANTIES OR GUARANTEES OF ANY KIND, EXPRESSED OR IMPLIED, INCLUDING ANY IMPLIED WARRANTY OR MERCHANTABILITY OR FITNESS FOR A PARTICULAR PURPOSE.**

In no event shall Blendtec be liable for any special, indirect, incidental or consequential damages. Upon the expiration of the warranty period, Blendtec's liability under this warranty shall terminate. The foregoing warranty shall constitute the sole liability of Blendtec and the exclusive remedy of the customer or user.

# FORM TO SEND WITH BLENDER FOR REPAIRS/REPLACEMENT

(Please make a copy of this form.)

-----

Name: \_\_\_\_\_

Company: \_\_\_\_\_

Store: \_\_\_\_\_

Address: \_\_\_\_\_

Phone #: \_\_\_\_\_

Serial # (found on the underside of the motor base): \_\_\_\_\_

Cycle Count: \_\_\_\_\_

Purchase Date: \_\_\_\_\_

Place of Purchase: \_\_\_\_\_

An explanation of the problem: \_\_\_\_\_

\_\_\_\_\_

\_\_\_\_\_

-----

Our goods come with guarantees that cannot be excluded under the Australian Consumer Law. You are entitled to a replacement or refund for a major failure and for compensation for any other reasonably foreseeable loss or damage. You are also entitled to have the goods repaired or replaced if the goods fail to be of acceptable quality and the failure does not amount to a major failure.