

BLOOMFIELD INDUSTRIES
2 ERIK CIRCLE, P. O. Box 280
Verdi, NV 89439
telephone: 775-689-5700
fax: 888-492-2783
www.wellsbloomfield.com

**OWNERS MANUAL
For**



COFFEE BREWERS

MODELS:

**0420 Automatic Airpot
Brewer**

INCLUDES:

Installation

Operation

Use & Care

Servicing Instructions



Model: 0420 Airpot Brewer

PRINTED IN CHINA

WARRANTY STATEMENT

All electrical equipment manufactured by BLOOMFIELD INDUSTRIES is warranted against defects in materials and workmanship for a period of one year from the date of original installation or eighteen (18) months from the date of shipment from our factory, whichever comes first, and is for the benefit of the original purchaser, except that:

- a. airpots carry a 30 day parts warranty only.
- b. dispensers; i.e., tea and coffee carry a 90 days parts warranty only, excludes decanters.

THE FOREGOING OBLIGATION IS EXPRESSLY GIVEN IN LIEU OF ANY OTHER WARRANTIES, EXPRESSED OR IMPLIED, INCLUDING ANY IMPLIED WARRANTY OF MERCHANTABILITY OR FITNESS FOR A PARTICULAR PURPOSE, WHICH ARE HEREBY EXCLUDED.

BLOOMFIELD INDUSTRIES DIVISION / SPECIALTY EQUIPMENT MANUFACTURING CORPORATION SHALL NOT BE LIABLE FOR INDIRECT, INCIDENTAL OR CONSEQUENTIAL DAMAGES OR LOSSES FROM ANY CAUSE WHATSOEVER.

This warranty is void if it is determined that upon inspection by an Authorized Service Agency that the equipment has been modified, misused, misapplied, improperly installed, or damaged in transit or by fire, flood or act of God.

It also does not apply if the serial nameplate has been removed or unauthorized service personnel perform service. The prices charged by Bloomfield Industries for its products are based upon the limitations in this warranty. Seller's obligation under this warranty is limited to the repair of defects without charge by a Bloomfield Industries Authorized Service Agency or one of its sub-agencies. This service will be provided on customer's premises for non-portable models. Portable models (a device with a cord and plug) must be taken or shipped to the closest Authorized Service Agency, transportation charges prepaid, for services.

In addition to restrictions contained in this warranty, specific limitations are shown below (Additional Warranty Exclusions). Bloomfield Industries Authorized Service Agencies are located in principal cities.

This warranty is valid in the United States and void elsewhere. Please consult your classified telephone directory or your food service equipment dealer; or, for information and other details concerning warranty, write to:

**Service Parts Department
Bloomfield Industries
P.O. Box 280
Verdi, NV 89439**

Phone: (775) 689-5700

Fax: (888) 492-2783

SERVICE POLICY AND PROCEDURE GUIDE ADDITIONAL WARRANTY EXCLUSIONS

1. Resetting of safety thermostats, circuit breakers, overload protectors, or fuse replacements unless warranted conditions are the cause.
2. All problems due to operation at voltages other than specified on equipment nameplates; conversion to correct voltage must be the customer's responsibility.
3. All problems due to electrical connections not made in accordance with electrical code requirements and wiring diagrams supplied with the equipment.
4. Replacement of items subject to normal wear, to include such items as knobs and light bulbs. Normal maintenance functions including adjustment of thermostats, microswitches, and replacement of fuses and indicating lights are not covered under warranty.
5. All problems due to inadequate water supply, such as fluctuating, or high or low water pressure.
6. All problems due to mineral/calcium deposits, or contamination from chlorides/chlorines. De-liming is considered a preventative maintenance function and is not covered by warranty.
7. Full use, care and maintenance instructions are supplied with each machine. Those miscellaneous adjustments noted are customer responsibility. Proper attention will prolong the life of the machine.
8. Travel mileage is limited to sixty (60) miles from an authorized Service Agency or one of its sub-agencies.
9. All labor shall be performed during normal working hours. Overtime premium shall be charged to the customer.
10. All genuine Bloomfield replacement parts are warranted for ninety (90) days from date of purchase on non-warranted equipment. **Any use of non-genuine Bloomfield parts completely voids any warranty.**
11. Installation, labor and job check-out are not considered warranty.
12. Charges incurred by delays, waiting time or operating restrictions that hinder the service technicians ability to perform services are not covered by warranty. This includes institutional and correctional facilities.

SHIPPING DAMAGE CLAIMS PROCEDURE

NOTE: For your protection, please note that equipment in this shipment was carefully inspected and packaged by skilled personnel before leaving the factory. Upon acceptance of this shipment, the transportation company assumes full responsibility for its safe delivery.

IF SHIPMENT ARRIVES DAMAGED:

1. **VISIBLE LOSS OR DAMAGE:** Be certain that any visible loss or damage is noted on the freight bill or express receipt, and that the note of loss or damage is signed by the delivery person.
2. **FILE CLAIM FOR DAMAGE IMMEDIATELY:** Regardless of the extent of the damage.

3. **CONCEALED LOSS OR DAMAGE:** if damage is unnoticed until the merchandise is unpacked, notify the transportation company or carrier immediately, and file "CONCEALED DAMAGE" claim with them. This must be done within fifteen (15) days from the date the delivery was made to you. Be sure to retain the container for inspection.

Bloomfield Industries cannot assume liability for damage or loss incurred in transit. We will, however, at your request, supply you with the necessary documents to support your claim.

TABLE OF CONTENTS

WARRANTY STATEMENT	xi
SPECIFICATIONS	1
FEATURES & OPERATING CONTROLS	2
PRECAUTIONS & GENERAL INFORMATION	3
AGENCY LISTING INFORMATION	3
INSTALLATION INSTRUCTIONS	4
OPERATION	7
Program Volume Select Keys	8
Brew Coffee	9
CLEANING INSTRUCTIONS	10
TROUBLESHOOTING SUGGESTIONS	11
SERVICING INSTRUCTIONS	12
Deliming Instructions	17
EXPLODED VIEW & PARTS LIST	18
WIRING DIAGRAMS	21

Thank You for purchasing this Bloomfield Industries appliance.

Proper installation, professional operation and consistent maintenance of this appliance will ensure that it gives you the very best performance and a long, economical service life.

This manual contains the information needed to properly install this appliance, and to use, care for and maintain or repair the appliance in a manner which will ensure its optimum performance.

SPECIFICATIONS

MODEL	STYLE	FEATURES	VOLTS	WATTS	AMPS 1ø	POWER SUPPLY CORD
0420	AUTOMATIC LO-PROFILE AIRPOT	HOT WATER DISPENSER	120 VAC	1500	12.5	NEMA 5-15P

Also meets Canadian Standards

APPLICABILITY

This manual applies to the following Bloomfield Industries product:
0420

FEATURES AND OPERATING CONTROLS - AUTOMATIC BREWERS

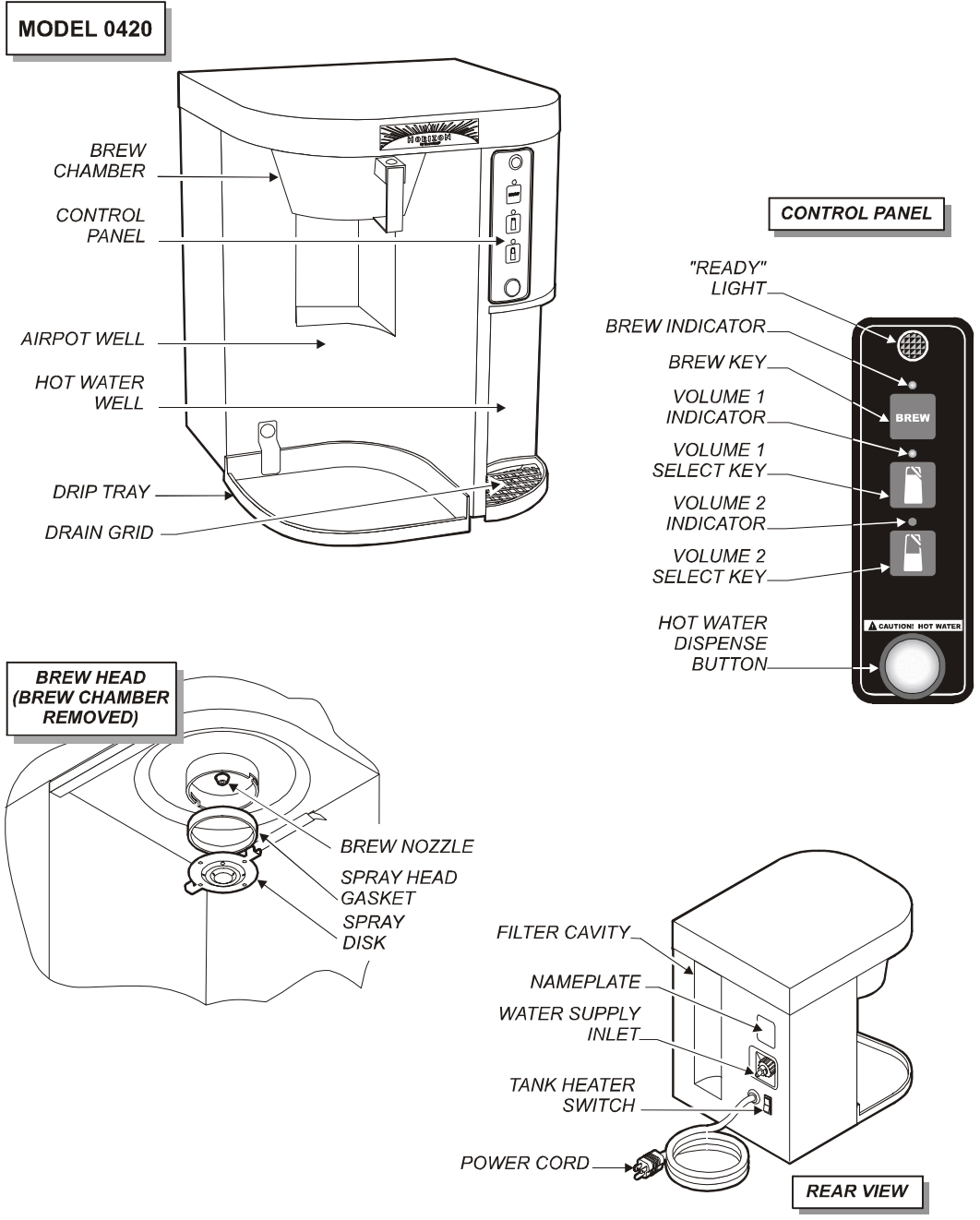

Fig. 1 Features & Operating Controls for Automatic Brewers

PRECAUTIONS AND GENERAL INFORMATION



WARNING: ELECTRIC SHOCK HAZARD

All servicing requiring access to non-insulated components must be performed by qualified service personnel. Do not open any access panels which require the use of tools. Failure to heed this warning can result in electrical shock.



WARNING: INJURY HAZARD

All installation procedures must be performed by qualified personnel with full knowledge of all applicable electrical and plumbing codes. Failure could result in property damage and personal injury.



WARNING: ELECTRIC SHOCK HAZARD

Brewer must be properly grounded to prevent possible shock hazard. DO NOT assume a plumbing line will provide such a ground. Electrical shock will cause death or serious injury.



WARNING: BURN HAZARD

This appliance dispenses very hot liquid. Serious bodily injury from scalding can occur from contact with dispensed liquids.

This appliance is intended for commercial use only.

This appliance is intended for use to brew beverage products for human consumption. No other use is recommended or authorized by the manufacturer or its agents.

This appliance is intended for use in commercial establishments, where all operators are familiar with the appliance use, limitations and associated hazards. Operating instructions and warnings must be read and understood by all operators and users.

The following trouble shooting, component views and parts lists are included for general reference, and are intended for use by qualified service personnel.

This manual should be considered a permanent part of this appliance. The manual must remain with the appliance if it is sold or moved to another location.



CAUTION: ELECTRICAL DAMAGE

DO NOT plug in or energize this appliance until all *Installation Instructions* are read and followed. Damage to the Brewer will occur if these instructions are not followed.



CAUTION: BURN HAZARD

Exposed surfaces of the appliance, brew chamber and airpot may be HOT to the touch, and can cause serious burns.

AGENCY LISTING INFORMATION

This brewer is  and  listed under UL file E9253.

This brewer meets  Standard 4 only when installed, operated and maintained in accordance with the enclosed instructions.



INSTALLATION

READ THIS CAREFULLY BEFORE STARTING THE INSTALLATION

IMPORTANT:

To enable the installer to make a quality installation and to minimize installation time, the following suggestions and tests should be done before the actual unit installation is started:



CAUTION: ELECTRICAL DAMAGE

DO NOT plug in or energize this appliance until all Installation Instructions are read and followed. Damage to the Brewer will occur if these instructions are not followed.



CAUTION: UNSTABLE EQUIPMENT HAZARD

It is very important for safety and for proper operation that the brewer is level and stable when standing in its final operating position. Provided adjustable, feet or legs must be installed at each corner of the unit. Failure to do so will result in movement of the brewer which can cause personal injury and/or damage to brewer.

Unpack the unit. Inspect all components for completeness and condition. Ensure that all packing materials have been removed from the unit.

Verify that the Spray Head Gasket and Spray Disk are properly installed.

LEVELING THE UNIT

Verify that an adjustable leg is installed at each of the five locations on the bottom of the brewer.

Set Brewer in its operating location. Level the Brewer. A spirit level should be placed on the top of the unit, at the edge, as a guide when making level adjustments.

Level the unit from left to right and front to back by turning the adjustable feet. Be sure all feet touch the counter to prevent tipping.

INSTALLATION (continued)

PLUMBER'S INSTALLATION INSTRUCTIONS

Brewer should be connected to a **POTABLE WATER, COLD WATER** line. Flush water line before connecting to Brewer.

DO NOT use a saddle valve with a self-piercing tap for the water line connection. Such a tap can become restricted by waterline debris. For systems that must use a saddle tap, shut off the main water supply and drill a 3/16" (minimum) tap for the saddle connection, in order to insure an ample water supply. Remember to flush the line prior to installing the saddle.

The brewer must be installed on a water line with average pressure between 20 PSI and 90 PSI. If your water pressure exceeds 90 PSI at anytime, a pressure regulator must be installed in the water supply line to limit the pressure to not more than 90 PSI in order to avoid damage to lines and solenoid.

A water shut-off valve should be installed on the incoming water line in a convenient location (Use a low restriction type valve, such as a 1/4-turn ball valve, to avoid loss of water flow thru the valve).

NSF requires that the brewer be able to be moved for cleaning underneath. Loops of copper tubing will satisfy this requirement. See Figure 2 below.

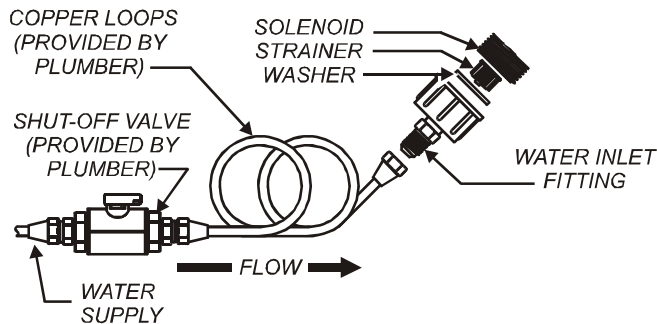

Fig. 2 Water Supply Installation

In some areas, local codes require a backflow preventer (check valve) to be installed on the inlet water line. If a backflow preventer is used, you must install a *water hammer arrester* in the incoming line, between the backflow preventer and the brewer inlet, as far away from the brewer as space will allow. This will relieve the excessive back pressures that can cause faucet leaks and solenoid malfunctions.



CAUTION: ELECTRICAL DAMAGE

DO NOT plug in or energize this appliance until all Installation Instructions are read and followed. Damage to the Brewer will occur if these instructions are not followed.

NOTE: Water supply inlet line must meet certain minimum criteria to insure successful operation of the brewer. Bloomfield recommends 1/4" copper tubing for installation of less than 12 feet and 3/8" for more than 12 feet from a 1/2" water supply line.

NOTE: This equipment must be installed to comply with applicable federal, state and local plumbing codes and ordinances.

IMPORTANT:

Water pressure must be between 20 p.s.i and 90 p.s.i. flowing pressure. If water pressure exceeds this value, or if water pressure varies greatly, a pressure regulator must be installed in the water supply line.

INSTALLATION (continued)



WARNING: **SHOCK HAZARD**

Brewer must be properly grounded to prevent possible shock hazard. DO NOT assume a plumbing line will provide such a ground. Electrical shock will cause death or serious injury.

IMPORTANT:

Supply power must match nameplate for voltage and phase. Connecting to the wrong voltage will damage the brewer or result in decreased performance. Such damage is not covered by warranty.

IMPORTANT:

Do not connect brewer to electrical power until you are ready to fill the tank. See instructions on page 7.

IMPORTANT:

The ground prong of the plug is part of a system designed to protect you from electrical shock in the event of internal damage. Never cut off the ground prong nor twist a blade to fit an existing receptacle. Contact a licensed electrician to install the proper circuit and receptacle.

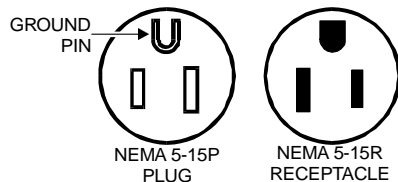

Fig. 3 Power Supply Plug

ELECTRICIAN'S INSTALLATION INSTRUCTIONS

REFER TO ELECTRICAL SPECIFICATIONS - Page 1
Check the nameplate to determine correct electrical service required for the Brewer to be installed.

IMPORTANT: Before connecting to electricity, make sure brewer is connected to the water supply.

All models are equipped with a cord and plug. They require a 115 - 125 volt 20 amp circuit (50/60 Hz, 2 wire plus ground, with NEMA 5-15R or 5-20R Receptacle).

See Figure 3 at right.

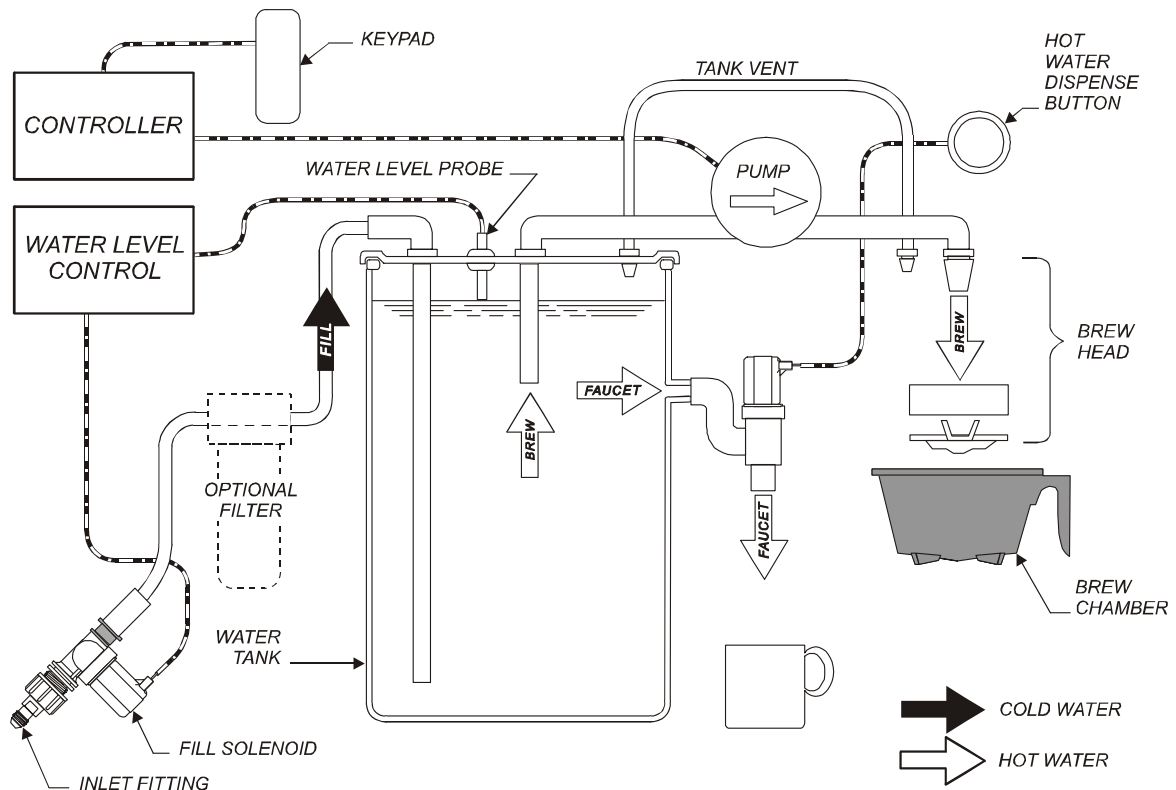

Fig. 4 Water Flow Diagram

A. START-UP

For initial start-up, or if the brewer has not been used for an extended period of time:

- ◆ Be sure spray disk and brew gasket are properly installed in the brew head.
- ◆ Be sure the water supply is properly connected and the water supply valve is turned *ON* and that **TANK HEATER SWITCH** is *OFF* before connecting brewer to electric power.
- ◆ Be sure the **WATER TANK IS FILLED**.

IMPORTANT: Fill the water tank before energizing this brewer.

1. Connect brewer to electric power. Brewer will begin filling. When solenoid closes, tank is full.
2. Place an empty container in the hot water well. Press the **HOT WATER DISPENSER BUTTON** and dispense one cup of water. Tank should refill. Discard water.
3. Press **TANK HEATER SWITCH** to *ON*.
4. When **READY** light glows, brewer is ready to use.

IMPORTANT:
TANK MUST BE FULL OF WATER BEFORE CONNECTING BREWER TO ELECTRIC POWER.

Heating elements will be damaged if allowed to operate without being fully submerged in water. Damage caused by operating the brewer without water in the tank is **NOT COVERED BY WARRANTY**.

See page 8 for setting delivered water volumes for **VOLUME SELECTION KEYS**.

OPERATION (continued)

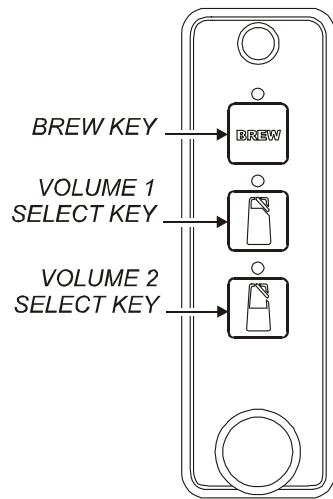

Fig. 5 Program Volumes

B. PROGRAM BREW VOLUMES

- ◆ Each BREW VOLUME SELECT KEY is individually programmable.
- ◆ Keys may be programmed for pulse brewing to optimize contact times and extraction rates, or to minimize overflowing the brew chamber when using large amounts of grounds.
- ◆ Up to 10 pulses may be programmed. Each pulse delay is fixed at 15 seconds.

1. Place an empty airpot under the brew head. Install the brew chamber (without filter) under the brew head
2. Press and hold BREW key until beep sounds and the indicator lights flash.
3. Press and release the VOLUME SELECT KEY to be programmed. Water will begin to flow into the airpot. When the desired water level is reached, press the key again to stop the water flow.

For pulse brew:

- a. Press the key to start the water flow.
- b. Press the key again to stop the flow after the time desired for the first pulse.
- c. Press the key again to resume water flow.
- d. Repeat until desired total delivered volume is reached.

NOTE: Water flow can be stopped and restarted up to 10 times per brew. The delay between pulses is fixed at 15 seconds.

4. Press the BREW KEY to enter these settings into memory and resume normal operation.
5. Run a normal brew with filter and grounds to verify settings.

Repeat steps 1 through 4 to program the other VOLUME SELECT KEY, or to revise existing settings.

OPERATION - BREWING COFFEE

A. PREPARATION

Place one (1) genuine Bloomfield paper filter in the brew chamber.
Add a pre-measured amount of fresh coffee grounds.
Gently shake the brew chamber to level the bed of grounds.
Slide the brew chamber into place under the brew head.

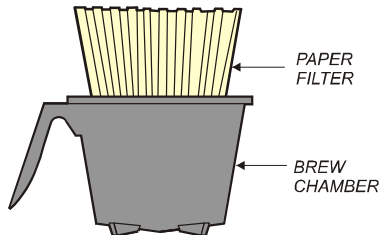

Fig. 6 Brew Chamber

B. AUTOMATIC OPERATION

Be sure "READY" light is lit.

Place the appropriate *EMPTY* airtop in place under the brew chamber.

Press the "BREW" key. A beep will sound and the BREW INDICATOR LIGHT will glow for the duration of the brew.

NOTE: VOLUME 1 (top key) is the default brew volume.

To brew the OPTIONAL volume:

Press and release the VOLUME 2 (bottom) KEY. The VOLUME 2 INDICATOR will glow. Press the "BREW" key. A beep will sound and the BREW INDICATOR LIGHT will glow for the duration of the brew.

At the conclusion of this brew, the system will revert to the default brew volume, the VOLUME 2 INDICATOR LIGHT will go out, and the VOLUME 1 INDICATOR LIGHT will glow.

The brew pump will operate for an amount of time determined by the selected brew volume, drawing a measured quantity of hot water from the tank.

The hot water will be forced into the brew head where it will spray over the bed of grounds. Freshly brewed coffee will begin to fill the container under the brew chamber. When the flow and all dripping stops, the coffee is ready to serve.

D. PREPARE FOR NEXT BREW

Discard the contents of the brew chamber and rinse it in a sink. When the "READY" light glows, the brewer is ready for another brew cycle.



CAUTION: BURN HAZARD

Exposed surfaces of the brewer, brew chamber and airtop may be HOT to the touch, and can cause serious burns.



CAUTION: BURN HAZARD

To avoid splashing or overflowing hot liquids, ALWAYS place an *EMPTY* airtop under the brew chamber before starting the brew cycle. Failure to comply can cause serious burns.



CAUTION: BURN HAZARD

After a brew cycle, brew chamber contents are HOT. Remove the brew chamber and dispose of used grounds with care. Failure to comply can cause serious burns.

NOTE: Excessive use of the hot water dispense function during a brew may decrease the amount of brew water delivered.

CLEANING INSTRUCTIONS



CAUTION: BURN HAZARD

Brewing and serving temperatures of coffee are extremely hot. Hot coffee will cause serious skin burns.



CAUTION: SHOCK HAZARD

Do not submerge or immerse brewer in water.

IMPORTANT:

DO NOT use steel wool, sharp objects, or caustic, abrasive or chlorinated cleansers to clean the brewer or airpots.

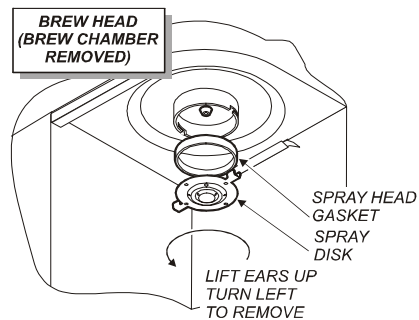

Fig. 7 Cleaning

PROCEDURE: Clean Coffee Brewer

PRECAUTIONS: Disconnect brewer from electric power. Allow brewer to cool.

FREQUENCY: Daily

TOOLS: Mild Detergent, Clean Soft Cloth or Sponge Bristle Brush, Bottle Brush

1. Disconnect brewer from electric power. Allow brewer to cool before cleaning.
 2. Remove airpot and any cup.
 3. Remove and empty brew chamber.
 4. Remove the spray disk from the brew head (See figure 7): Press up on the spray disk ears, then turn the disk to the left to unlatch. Remove the gasket from inside the brew head.
 5. Wipe inside of brew head and area around the brew head with a soft clean cloth or sponge moistened with clean water.
 6. Wash the spray disk in a sink using warm water and a mild detergent. A bristle brush may be used to clear clogged spray holes. Rinse the spray disk with clean water and allow to air dry.
 7. Wash the brew chamber in a sink using warm water and a mild detergent. A bristle brush may be used to clean the inside. Rinse with clean water and allow to air dry.
 8. Remove airpot drip tray and both grids. Wash in a sink using warm water and a mild detergent. Wipe out hot water drip tray with a soft cloth or sponge moistened with warm water. Reinstall drip tray and grids.
 9. Wipe the exterior of the brewer with a soft clean cloth or sponge moistened with clean water.
 10. Reinstall the gasket *INSIDE* the brew head, then reinstall the spray disk.
 11. Reinstall the brew chamber.
 12. Clean airpots by filling with warm soapy water. Scrub the inside with a bottle brush. Empty and rinse with clean water. Wipe the exterior with a soft clean cloth or sponge moistened with clean water. Invert and allow to air dry.
- IMPORTANT:** DO NOT submerge airpots in water.

Procedure is complete

TROUBLESHOOTING SUGGESTIONS

SYMPTOM	POSSIBLE CAUSE	SUGGESTED REMEDY
Water won't heat	Brewer unplugged or circuit breaker tripped	Check power supply cord Check / reset circuit breaker
	Temperature setpoint too low	Set for desired temperature
	Hi-Limit safety switch tripped	Allow to cool hi-limit will self-reset
	Damaged internal component or wiring	Examine wiring & connectors, controller, water level probe and heating element Repair/replace as needed
Coffee level too high or low	Volume keys not programmed	Program volume keys
Brew chamber overflows	Too many filter papers or wrong filter paper	Use one (1) genuine Bloomfield filter per brew
	Brew chamber dispense hole plugged	Thoroughly clean brew chamber
	Too much coffee or too fine a grind	Use correct grind and amount of coffee
	Not using pulse brew feature	Program vol. key for pulse brew
Sprays water from brew head	Spray gasket improperly installed	Check/reinstall gasket on INSIDE of brew head
	Spray disk plugged	Clean spray disk
No brew (faucet flows OK)	Damaged internal component or wiring	Check keypad, controller, and pump Repair, replace as needed
No brew plus no flow from hot water faucet	Water supply OFF	Turn water supply ON
	Solenoid inlet strainer plugged	Clean strainer
	Water filter (if used) plugged	Replace filter element
	Damaged internal component or wiring	Check controller and water level probe
No flow from hot water faucet (brew OK)	Damaged internal component or wiring	Check solenoid and switch Repair/replace as needed
Poor coffee quality	Keep brewer and airpots clean. Install optional taste and odor filter, and replace cartridges regularly. Use a quality coffee with a consistent roast. Use proper grind and amount of coffee per brew.	

SERVICING INSTRUCTIONS



CAUTION: SHOCK HAZARD

Opening access panels on this brew may expose uninsulated electrical components. Disconnect brewer from electrical power before removing any panel.

Trouble shooting instructions, component views and parts lists in this manual are included for general reference, and are intended for use by qualified service personnel only.

ACCESS PANELS

TOP PANEL:

Remove top panel to access hot water tank, thermostat, heating elements, brew pump and tubing, hot water dispenser solenoid and piping,

Top panel is held by screws around the edge.

FRONT PANEL:

Remove front panel to access controller.

Remove airpot drip tray. Front panel is held by screws on the vertical edges and a retaining lip at the top.

SOLENOID DOOR:

Remove solenoid door to access solenoid plumbing connections.

Solenoid door is held by two screws and a retaining lip.

SERVICING INSTRUCTIONS (continued)

TEMPERATURE ADJUSTMENT

Disconnect brewer from electric power. Remove top panel. Remove button plug from front panel.

Pull vent tube out of tank lid and insert a thermometer of known accuracy in hole. Reconnect brewer to electrical power. Place empty container under brew chamber. Energize brewer and allow unit to heat. When READY light glows, read the temperature displayed on thermometer.

Adjust thermostat by turning shaft; clockwise increases temperature. 1/8 turn = approximately 10°F. Refer to Table 1 below for proper brewing temperature based on altitude.

Upon completion, remove thermometer and reinstall the plug.

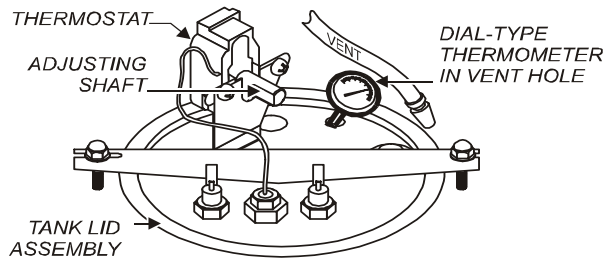

Fig. 9 Checking and Adjusting Brew Temperature

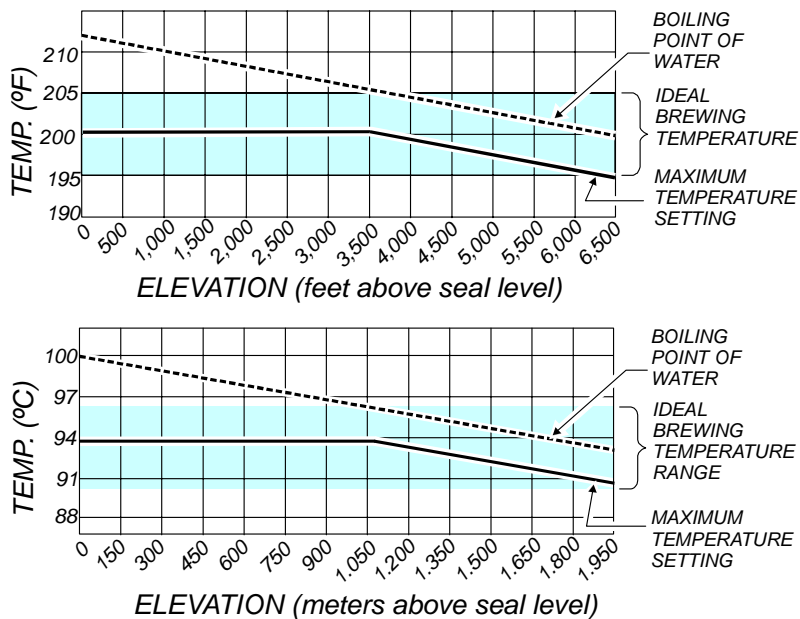

Table 1 Boiling Temperature by Altitude



CAUTION: SHOCK HAZARD

These procedures involve exposed electrical circuits. These procedures are to be performed by qualified technical personnel only.

NOTE:

Optimum brewing temperature range is 195°F to 205°F (90°C to 96°C).

IMPORTANT:

A mechanical thermostat will maintain temperature within $\pm 5^\circ\text{F}$. To prevent boiling water in the brewer, thermostat should be adjusted to a maximum temperature equal to the local boiling temperature minus 5°F.

SERVICING INSTRUCTIONS (continued)

IMPORTANT:

Before setting assembly into tank, make sure tank lid gasket is properly seated on flange of lid. *DO NOT OVER-TIGHTEN.*

IMPORTANT:

When mounting thermostat, be sure to insert sensing bulb to the bottom of the bulb well. Tighten capillary lock nut only enough to ensure no water leakage. Excessive tightening is not necessary.

IMPORTANT:

When replacing heating element, also replace seal gaskets.

REMOVE TANK LID ASSEMBLY

Disconnect brewer from electric power. Turn *OFF* water supply. Remove top panel. Pull vent tube, inlet elbow, outlet elbow and water level probe out of basin pan.

Disconnect all wiring from thermostat, hi-limit, and heating element.

Loosen nuts on tank hold-down strap. Remove hold-down strap by sliding short slotted end off of locking stud and lifting it off. Remove cover assembly by lifting it straight up.

Reassemble in reverse order.

REPLACE THERMOSTAT (COTHERM)

Disconnect brewer from electric power. Turn *OFF* water supply. Remove top panel.

Disconnect all wiring from thermostat only. Loosen and free jam nut from pass-thru fitting securing temperature sensing bulb. Remove two screws holding thermostat to bracket.

Lift out thermostat, sensing bulb and thermostat gasket.

Reassemble in reverse order. **BE SURE** the bulb well is fully seated in the tank fitting, and that the temperature sensing bulb is inserted to the very bottom of the bulb well.

REPLACE HEATING ELEMENT

Remove tank lid assembly per above.

Remove two hex nuts holding element to cover. Pull element from mounting holes.

Reassemble in reverse order.

SERVICING INSTRUCTIONS (continued)

IMPORTANT:

The two keypad ribbon cables connectors are not polarized, and can easily be installed on the wrong location on the board. Be sure to mark the ribbon cable connectors as to location and orientation.

REPLACE CONTROLLER

Disconnect brewer from electric power. Remove top panel and front panel.

Note location of wire connections. Be sure to mark the two keypad ribbon cables as to location and orientation. Disconnect wiring from controller.

Remove four nuts holding controller to cabinet.

Reassemble in reverse order.

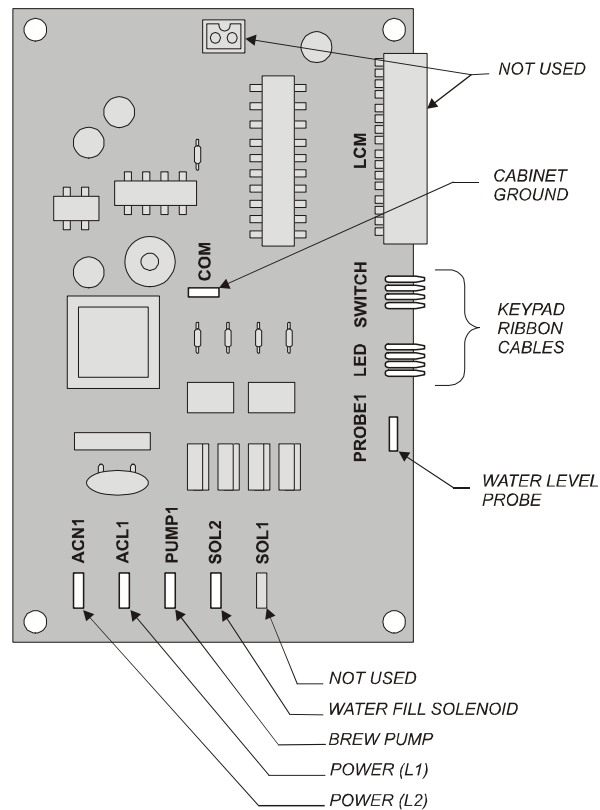

SERVICING INSTRUCTIONS (continued)

PROCEDURE: Delime the Water Tank

PRECAUTIONS: Disconnect brewer from electric power.
Allow brewer to cool.

FREQUENCY: As required (Brewer slow to heat)

TOOLS: Deliming Solution
Protective Gloves, Goggles & Apron
Mild Detergent, Clean Soft Cloth or Sponge
Bristle Brush, Bottle Brush
Large Sink (or other appropriate work area)

1. Disconnect brewer from electric power. Turn off the water shut-off valve and disconnect the water supply line from the brewer inlet fitting.
2. Remove the tank lid assembly as described on page 13.
3. Remove the water tank from the brewer body by lifting straight up. Empty all water from the tank. Set the tank back into the brewer.
4. Mix 2 quarts of deliming solution according to the manufacturer's directions. Carefully pour the deliming solution into the water tank. Lower the lid assembly back onto the tank. Allow to sit for 30 minutes, or as directed by the manufacturer.
5. At end of soaking period, remove lid assembly from tank. Thoroughly rinse internal components of lid assembly with clear water. Using a stiff bristle brush, scrub the heating element (and faucet water coil on automatic brewers) to remove lime and calcium build-up. Rinse with clean water. Store lid assembly in a safe location .
6. Remove the tank from the brewer and empty. Using a stiff bristle brush, scrub the interior of the water tank to remove lime and calcium build-up. Rinse with clean water.
7. Set the tank back into the brewer. Reassemble the tank lid to the water tank. Make sure the gasket is properly in place, then reinstall the hold-down strap.
8. Reinstall wiring to heating element and thermostat. Reinstall the hi-limit thermostat (if removed). For automatic brewers, reassemble piping for the faucet. Verify that all internal components are dry, then reinstall the top panel.
10. Reconnect brewer to electrical supply and, for automatic brewers, reconnect water supply.
11. Install the brew chamber without filter paper or grounds. Run at least three full brew cycles and discard all water generated.
12. Brewer is ready to use.



CAUTION: CHEMICAL BURN HAZARD

Deliming chemicals may be caustic. Wear appropriate protective gloves and goggles during this procedure. Never siphon deliming chemicals or solutions by mouth.

This operation should only be performed by qualified and experienced service personnel.

IMPORTANT: DO NOT spill, splash or pour water or deliming solution into or over any internal component other than the inside of the water tank.

IMPORTANT: DO NOT allow any internal components to come into contact with the deliming solution. Take care to keep all internal components dry.

NOTE: Repeat steps 4 thru 5 as required to remove all scale and lime build-up.

NOTE: Normally, silicone hoses do not need to be delimed. Should deliming hoses become necessary, Bloomfield recommends replacing the hoses.

0420 EXPLODED VIEW & PARTS LIST

CABINET & ELECTRICAL COMPONENTS

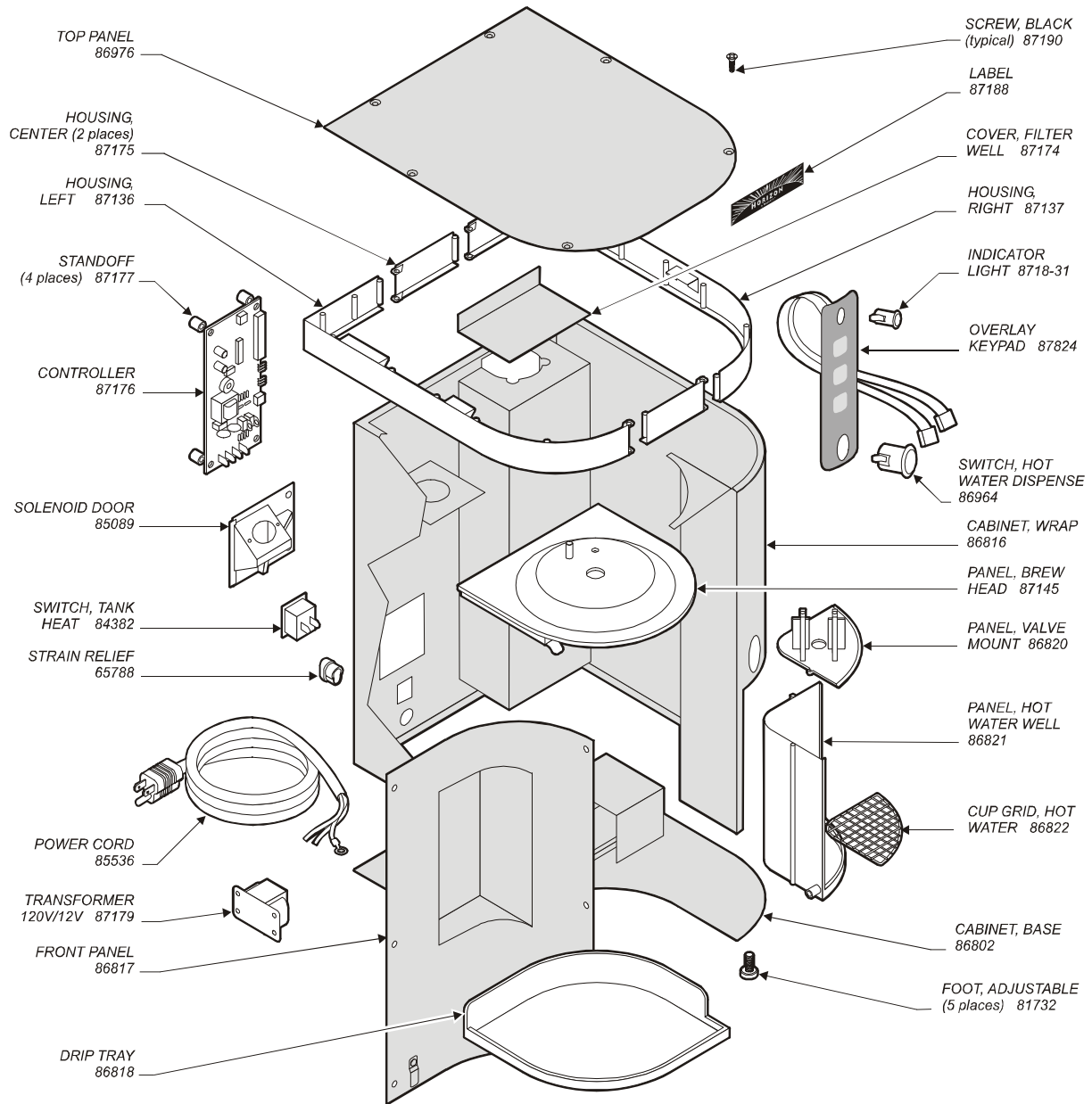

0420 EXPLODED VIEW & PARTS LIST (continued)

PLUMBING COMPONENTS

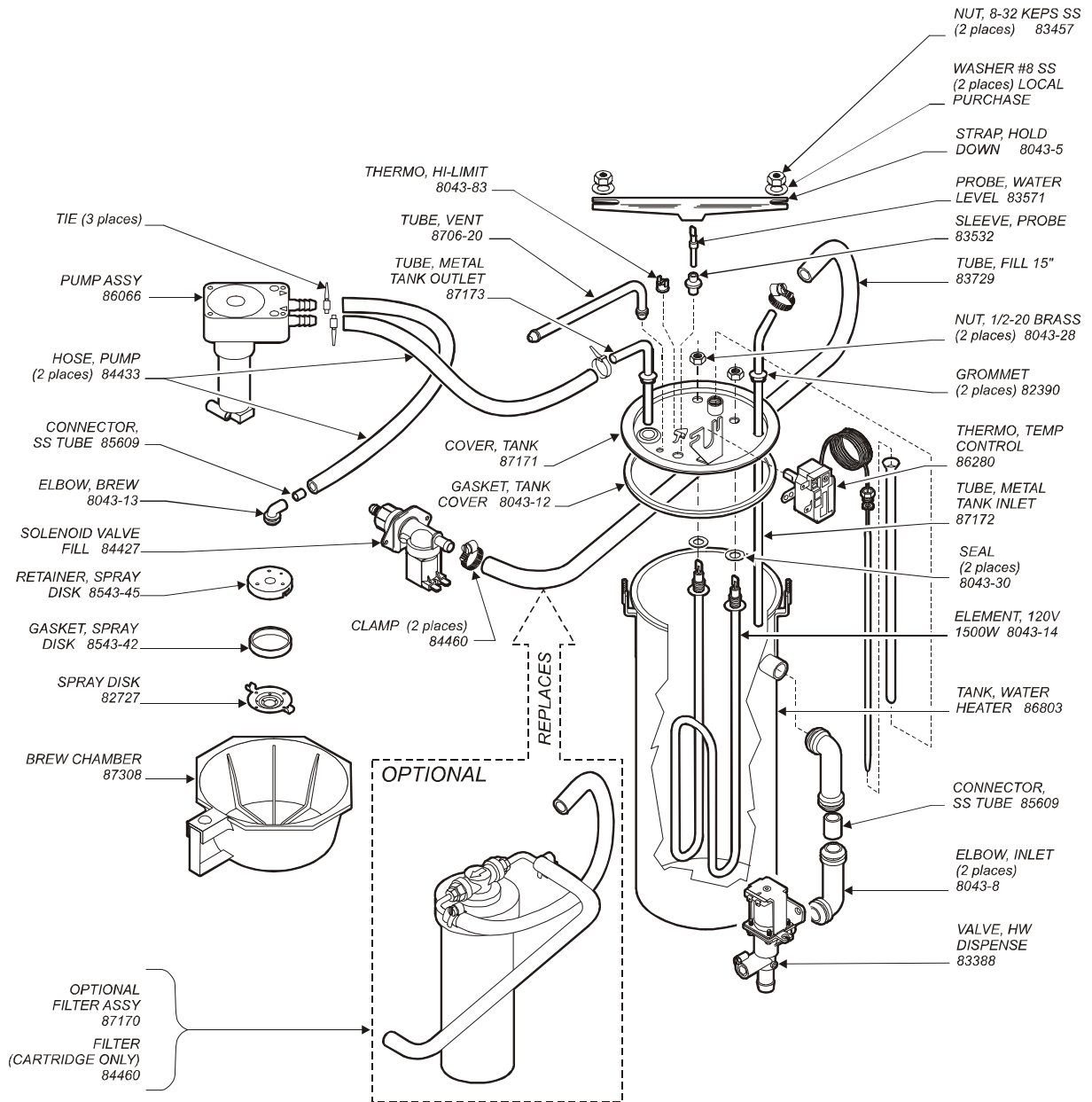

WIRING DIAGRAM

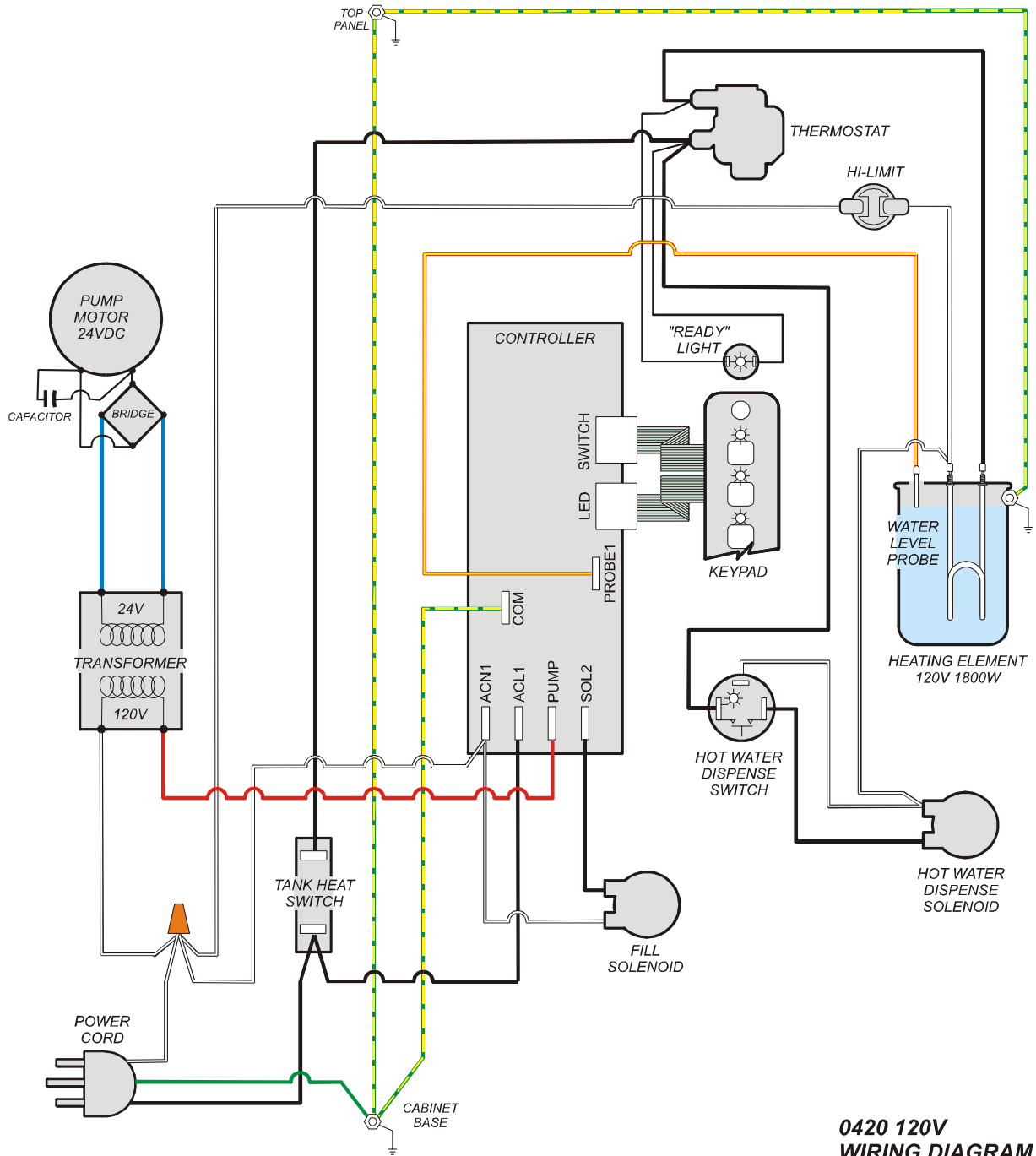

**0420 120V
WIRING DIAGRAM**

CFESA

Commercial Food Equipment Service Association

Bloomfield Industries proudly supports CFESA
Commercial Food Equipment Service Association

SERVICE TRAINING - QUALITY SERVICE



CUSTOMER SATISFACTION



BLOOMFIELD

Bloomfield Industries, Inc.
Division of Carrier Commercial Refrigeration

In US and Canada

Telephone: 775-689-5700

Fax: 888-492-2783

Fax: 800-356-5142 (*for orders only*)

website: www.wellsbloomfield.com

PRINTED IN CHINA