



**Reach ins, Freezers & Refrigerators
Installation & Operation Manual**



CAUTION!

PLEASE KEEP POWER SWITCH ON
BEFORE OPERATING THE UNIT



ATTENTION!

GARDEZ EN BOUTON ALLUME
AVANT D'OPERER L'UNITE

Please read this manual completely before attempting to install or operate this equipment!



**BSR23T
BSF23T**

**BSR49T
BSF49T**

**BSR72T
BSF72T**

Blue Air reserves the right to make product modification at any time. Specifications and Designs are subject to change without notice.

IMPORTANT SAFETY INSTRUCTIONS (SAVE THESE INSTRUCTIONS)

Visit us on the web at www.blueairinc.com

Contents

◆ Specifications	3
◆ Serial Number	3
◆ Installation	4
◆ Cleaning	5
◆ Caution	5
◆ Operation	
Refrigerator	6
Freezer	8
◆ Trouble-Shooting	10

Service Contact

Blue Air Refrigeration has a Nationwide Service Network
to provide timely services to our customer's needs.
Please call or fax us at the following numbers.

Blue Air Refrigeration Nationwide Service Network
TEL, (310) 808-0102
Fax, (310) 808-0242/0262
Toll Free, 1-866-677-8500

Specifications

Model		BSR23T	BSR49T	BSR72T	BSF23T	BSF49T	BSF72T
Gross Capacity (cu.ft)		23	49	72	23	49	72
Exterior Dimensions (Including Casters) [in]	W	26 3/4	54	81	26 3/4	54	81
	D	31	31	31	31	31	31
	H	82 3/8	82 3/8	82 3/8	82 3/8	82 3/8	82 3/8
Net Weight (lbs)		233	348	503	248	381	556
Type of refrigeration system		Indirect cooling (Fan blowing)					
Control		Digital Control					
Casters or Legs	Front	2, swivel with brake		3, swivel with brake	2, swivel with brake		3, swivel with brake
	Rear	2, swivel		3, swivel	2, swivel		3, swivel
Shelves		4EA	8EA	12EA	4EA	8EA	12EA
Illumination (Incandescent lights)		1		2	1		2
Number of Doors		1	2	3	1	2	3
Door Auto Closer		Equipped					
Door Stopper		Equipped					
Rated Voltage		AC115V / 60Hz					AC 115 / 208~ 230V/60Hz
Type of Power Cord		NEMA 5-15P					NEMA L14-20P
Amps		5.0A	6.3A	11.1A	8.0A	10.5A	8.7/4.9A
Compressor (HP)		1/3 HP	1/3 HP	5/8 HP	1/2 HP	3/4 HP	1HP
Refrigerant		R-134a	R-134a	R-134a	R-404A	R-404A	R-404A
Range of Temperature		28 ~ 39°F			Below 0°F		

◆ Specifications and Designs are subject to change without notice for quality improvement.

Serial Number

- ◆ The serial number is located on the rating label which is on the left interior wall. Please retain the unit's serial number for service purpose.

Installation

1. GOOD AIR CIRCULATION

- Make sure to avoid any object which will interrupt or block the air flow inside the unit.
- Make sure to leave enough space toward the interior rear wall to ensure good air circulation
- Make sure to keep 5 inch space between the back of the unit and the wall.

2. PLACE ON STRONG GROUND

- Place the unit on a floor strong enough to hold

3. DO NOT PLACE NEAR HEAT SOURCE

- Make sure to avoid hot corner or any location near stove, oven, or other heat source.
- High ambient temperature will cause cooling efficiency to drop.

4. INDOOR USAGE ONLY

- This equipment is intended for indoor use only.

5. STABILIZING

- Make sure the unit is installed in a stable condition with the front wheels locked while in use.

6. LEVELING

- Make sure that the unit is leveled well from front to back and side to side.

7. Unit should be connected to a dedicated electrical circuit.

- Do not use extension cords.
- Plug the unit to a dedicated electrical circuit & adequate capacity.

8. Install plastic condensate pan in the bottom of the unit.

- Make sure pads are installed upwards and drain hose is in pan.

9. Install the unit in a place where the air circulation is good.

- Maintain enough spaces around the unit since air to ensure the best cooling performance
- If air circulation is obstructed, then cooling performance will drop, thus consuming more electricity as a result.

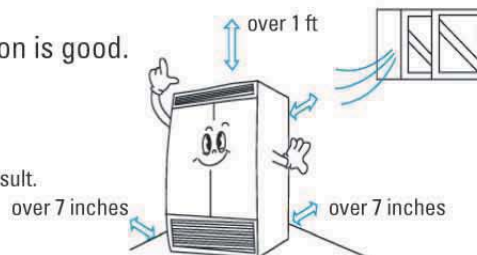

※ Reference

- If a left-hinge door is needed, please contact the sales representative in your area.
- A set of door hinge can be purchased separately to convert between right -hinge door and left-hinge door.

Cleaning



WARNING - To reduce the risk of electric shock, unplug before cleaning or servicing.

1. CLEANING THE INTERIOR AND EXTERIOR

- The interior and exterior of the unit can be cleaned using warm water with soap.
- Do not use an abrasive cleaner because it will scratch the surface.

2. CLEANING THE CONDENSER FINS

- To maintain proper refrigeration performance, the Condenser coil must be free of dust, dirt, and grease. It will require to clean it periodically. Condenser fins should be cleaned, at least every three months (90 days) or as needed.

3. CLEANING THE GASKET

- The door gasket should be cleaned frequently to maintain proper sealing. Use warm water and a mild soap.

4. CLEANING THE EVAPORATOR

- If you need to clean the evaporator, please contact the qualified service technicians.

5. CHECK AFTER CLEANING

- Check the unit again for safety.
- Check if the unit is operating properly.

Caution

1. POWER CORD

- Make sure the power cord is connected to the proper voltage. (115V, 60Hz)
- Compressor warranties are void if compressor burns out due to a usage of improper voltage.
- A protected circuit of the correct voltage and amperage must be used for connection of the line cord.
- Turn 'off' the power switch before disconnecting the power cord whenever performing maintenance service or cleaning the refrigerated cabinet.
- If the power cord of Refrigerator (Freezer) is damaged, it should be replaced by the manufacturer or service agent or a similarly qualified person in order to avoid a hazard.

2. RE-STARTING

- If disconnected, wait 5 minutes before re-starting.

Operation

BSR23T
BSR49T
BSR72T

Refrigerator

1. Plug in and turn on the power switch located on the bottom of the top grill.
The Display panel will be lighted. The compressor will begin to run.
2. The default temperature setting is 35°F (+2°C)
3. The compressor is automatically cycled by the electronic controller (PCB).
4. Temp. Control range is 39°F ~ 28°F (+4°C ~ -2°C)
5. The interior light is activated by the door switch when the door is open.
6. Evaporator fan motor(s) will run after all doors are completely closed.

Operation

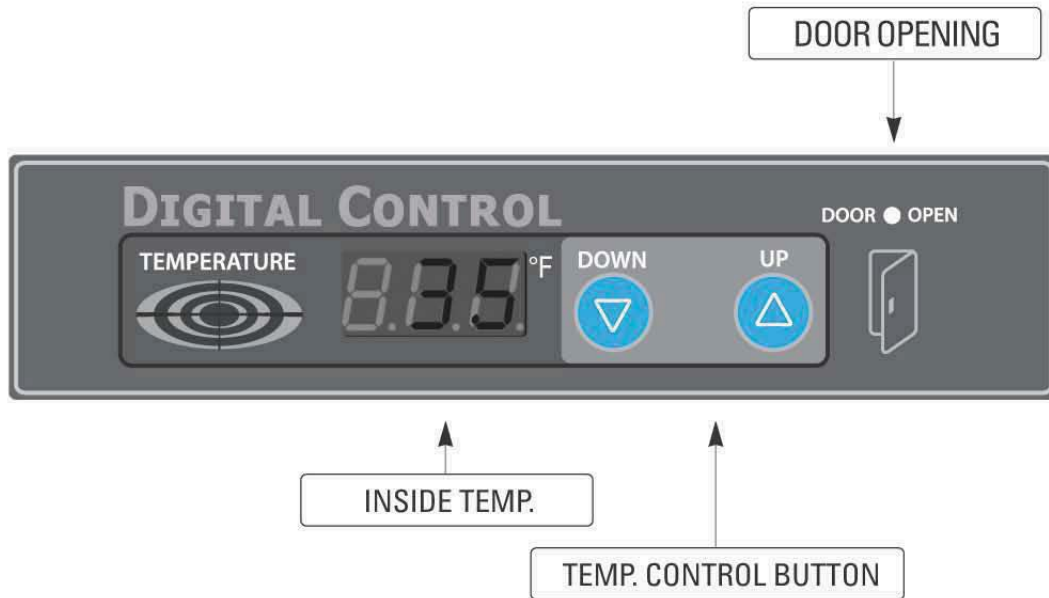

1. UP / DOWN BUTTON (Temperature control button)

- By pushing the up/down button, you can set the cabinet temperature.

2. DOOR OPENING INDICATOR

- If door is opened, door opening indicator will be turned on.
- If the door is left open for 5 minutes, the alarm will sound continuously.
- The alarm will stop immediately upon closing the door.

Operation

BSF23T
BSF49T
BSF72T

Freezer

1. Plug in and turn on the power switch located on the bottom of the top grill.
The Display panel will be lighted. The compressor will begin to run.
2. The default temperature setting is 0°F (-18°C)
3. The compressor is automatically cycled by the electronic controller (PCB, D-sensor).
4. The Defrost cycle is automatically controlled by the D-sensor and the PCB
5. Temp. Control range is 5°F ~ -9°F (-15°C ~ -23°C)
6. The interior light is activated by the door switch at the bottom of the grill when the door is opened.
7. Evaporator fan motor(s) will run after all doors are completely closed.

Operation

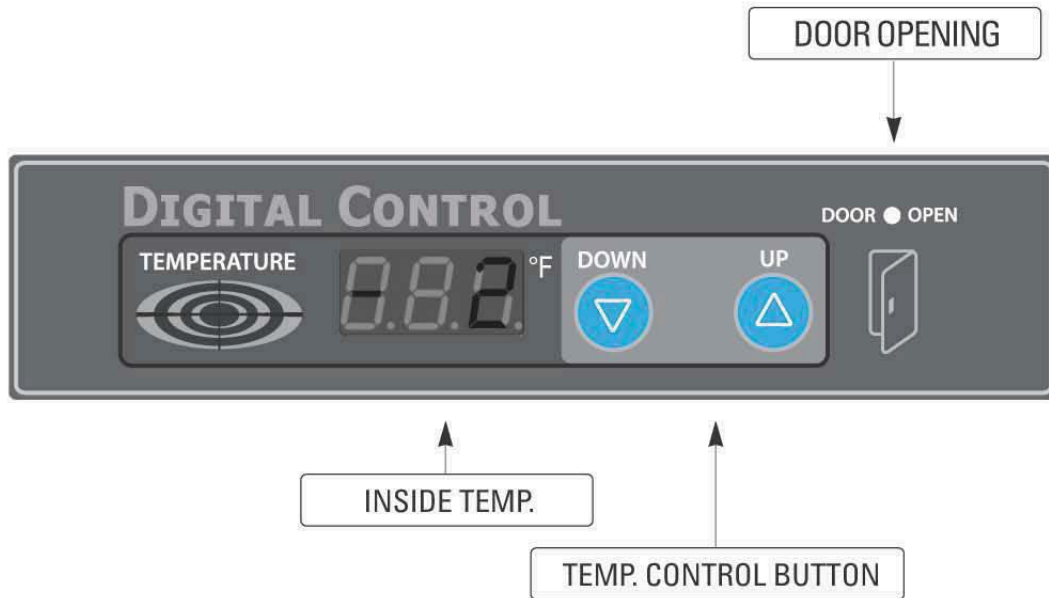

1. UP / DOWN BUTTON (Temperature control button)

- By pushing the up/down button, you can set the cabinet temperature.

2. DEFROST

- The electronic defrost controller is set at the factory to provide a defrost cycle every 8 hours.
- Once all frost is eliminated, the defrost control is changed to the freezer mode.
- The panel displays "dF" during the defrost.

3. DOOR OPENING INDICATOR

- If door is open, door opening indicator will be turned on.
- If the door is left open for 5 minutes, the alarm will sound continuously.
- The alarm will stop immediately upon closing the door.

Trouble-Shooting

SYMPTOMS	CAUSES	SOLUTIONS
Refrigerator/Freezer is freezing (thawing) food.	<ul style="list-style-type: none"> • The Temp. is set too low (high) 	<ul style="list-style-type: none"> • Push the button to a warmer (colder) position.
The unit does not refrigerate at all.	<ul style="list-style-type: none"> • There may be a power connection failure problem. 	<ul style="list-style-type: none"> • Check the power cord to make sure the unit is plugged in correctly.
The unit does not refrigerate well .	<ul style="list-style-type: none"> • The unit is in sunlight or near a heating device. • The unit contains hot food or too much food. • The unit door is opened too frequently or left open too long. • The temp. Is not set on the correct position. • The condenser is clogged. 	<ul style="list-style-type: none"> • Check the location of the unit. • Check the condition of stored food. • Check the position of the temperature setted. • Clean condenser.
There is a loud noise.	<ul style="list-style-type: none"> • The floor is too weak or the unit is not leveled. • The back -side of the unit is too close to the wall. • The tray is not in the correct position. 	<ul style="list-style-type: none"> • Check the installation and adjust the tray position.
There is condensation on the unit exterior.	<ul style="list-style-type: none"> • High -moisture air or humidity can cause dew-drops or condensation 	<ul style="list-style-type: none"> • Wipe with a dry cloth.
There is condensation on the interior of the unit.	<ul style="list-style-type: none"> • The door is opened too frequently or left open too long. • Damp food is stored. 	<ul style="list-style-type: none"> • Keep the door closed to remove condensation.
The door does not close tightly	<ul style="list-style-type: none"> • The door is bent. • The door gasket has come off or worn out. • The unit is not leveled. 	<ul style="list-style-type: none"> • Reposition or replace the gasket. • Level the unit again.

Disassembly & Assembly Manual for Rear Shelf

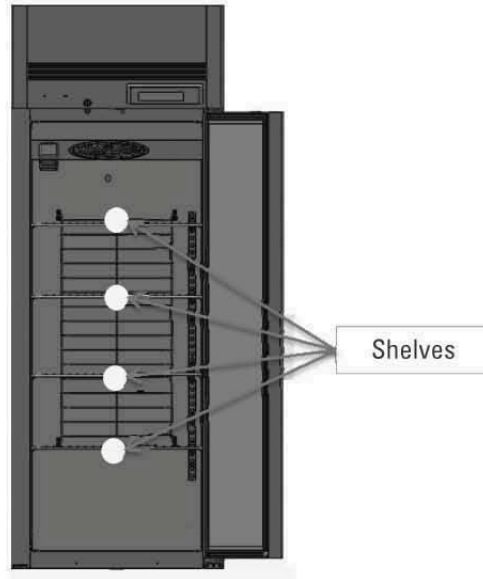

Shelves are assembled.

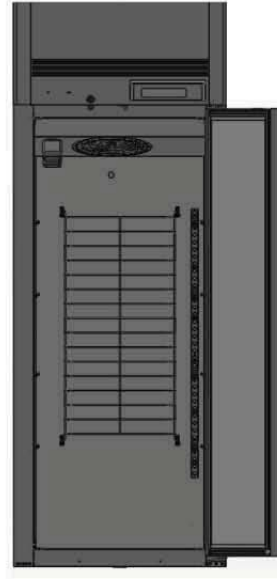

1. Disassemble shelves.

(23Model : 4EA , 49Model : 8EA , 72Model : 12EA)

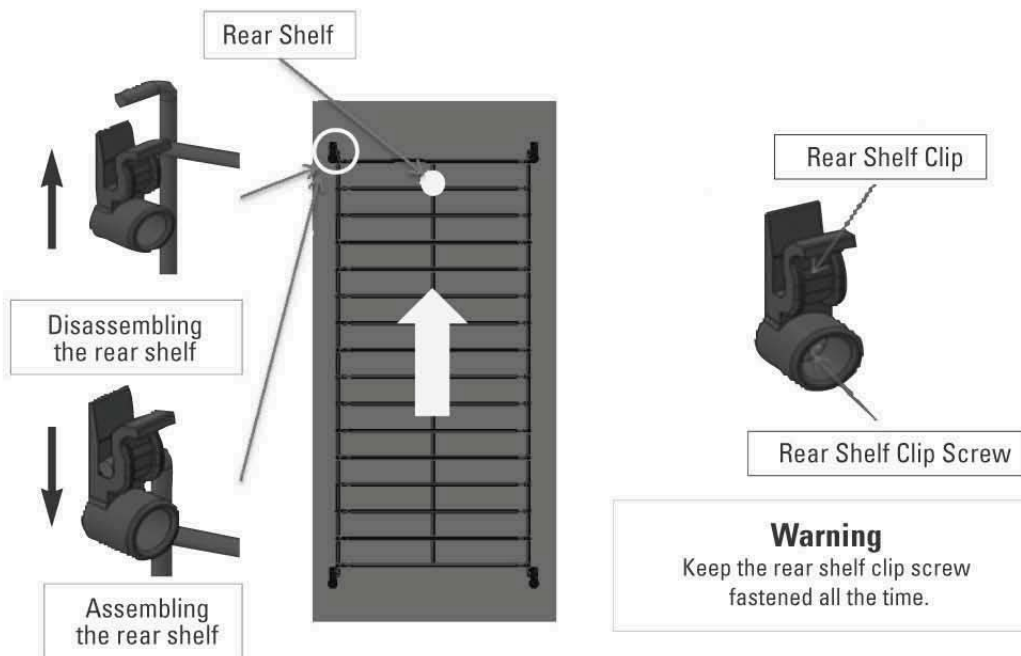

2. Push the rear shelf up or down to the directions as shown above to disassemble or reassemble it.

WARRANTY CERTIFICATE

Warranty Valid Only In the USA

This warranty is subject to all of the terms and conditions listed below. On-line warranty registration or Warranty card furnished with this unit must be properly executed and returned to BLUE AIR immediately after installation. Failure to complete on-line registration or, to return the warranty registration card to provided location will automatically void all warranties.

Standard Warranty

One(1) Year Parts & Labor Warranty: (On Selected Products – Chest Freezers)

BLUE AIR warrants to the original purchaser of the BLUE AIR unit sold and all parts thereof to be free from defects in material or workmanship, under normal use and service for a period of one (1) year from the date of sale by Distributor or Dealer, or fifteen (15) months from date of shipment by Blue Air, whichever occurs first. Unit lamps are **NOT** included in the warranty. Our obligation under this warranty shall be limited to repairing or replacing F.O.B. factory any of such products that prove to be defective and which our examination shall disclose to our satisfaction to be defective.

Two (2) Years Parts and Labor Warranty: (On Selected Products – All refrigeration equipment except Chest Freezers)

BLUE AIR warrants to the original purchaser the BLUE AIR unit sold and all parts thereof to be free from defects in material or workmanship, under normal use and service for a period of one and two years from the date of sale or twenty one (27) months from date of shipment by Blue Air, whichever occurs first. Unit lamps are NOT included in the warranty. Our obligation under this warranty shall be limited to repairing or replacing F.O.B. factory any of such products that prove to be defective and which our examination shall disclose to our satisfaction to be defective.

- A) Any part returned to the company under the terms of this warranty must be accompanied by the record of the cabinet model number, serial number, return authorization number and such return shall be on the basis of TRANSPORTATION CHARGES PREPAID.
- B) Improper operation due to low voltage condition, inadequate wiring and accident damages are not manufacturing defects and are strictly the responsibility of the purchaser.
- C) Condenser coils must be cleaned at regular intervals. Failure to do so may cause the compressor to malfunction and will void the warranty. This contract does not apply outside the limits of the U.S.A. nor does it to any part which has been subject of misuse, neglect, alteration, accident or to any damage caused by transportation, flood, fire, or the acts of God. This contract is not effective unless the BLUE AIR Warranty Card, furnished with each unit, is properly filled out and mailed back to BLUE AIR within twelve (12) days from the date of installation. The term "Original Purchaser" as used herein shall be deemed to refer to that person, firm, association, or company for whom the refrigeration unit refers to herein is originally installed.

Extended Warranty

One (1) year extended warranty for parts & labor is available for purchase at the time of purchasing equipment from our dealers.

Five-Year Compressor Warranty

BLUE AIR warrants the hermetically sealed compressor for an 60 months, for the **STAINLESS STEEL REACH-INS, PREP TABLES, PIZZA PREP UNDERCOUNTERS, CHEFBASES, UNDERBAR REFRIGERATION EQUIPMENT, GLASS DOOR REACH-INS, CHEST FREEZERS/COOLERS and COUNTER TOP REFRIGERATION EQUIPMENT.** Not to exceed sixty three(63) months from the date of shipment from Blue Air warehouse, provided upon receipt of the compressor manufacturer examination shows the sealed compressor to be defective. Lack of maintenance will result in a voided warranty. This extended warranty does not apply for any electrical controls, accumulator or wiring harnesses which are covered by the standard warranty.

Warranty Claims

All labor claims or parts must include copy of original invoice submitted directly to Blue Air. All claims must include: a copy of original invoice (Customer Name, address, model name, and Date of Sale) Customer Name, Phone Number, Model & Serial No of unit, date of sale, Distributors or Dealers name and brief description of complaint. On all compressor warranties the compressor model tag must be returned to Blue Air along with the above information. All claims must be reported to Blue Air within one (1) year of occurrence. All compressors have five (5) years warranty coverage. This warranty will not be effective unless the warranty card is returned or registered (www.blueairinc.com) to Blue Air within 12 days of installation. Confirm receipt of warranty registration by contacting Blue Air directly (1-866-677-8500)

Non Warranty Claims

Blue Air's warranty service is limited to labor of repairing merchandise and/or parts replaced. This warranty does not authorize any person(s) to assume any obligation or liability other than what the warranty permits. This warranty will be void if such action occurs. Any attempt to repair BLUE AIR products without an official job number issued by BLUE AIR will not be covered by warranty and the services will not be compensated. This warranty does not apply to any part, which has been subject to misuse, neglect, alteration, accident, or to any visible or concealed damage caused by transportation, flood, fire, acts of God, etc.

Concealed Damage Example

Styrofoam may hide any hidden dents on the shipment that may not be completely visible. You must inspect all corners and grills thoroughly. If the carrier stacks any contents on the units this can cause glass on the glass door units to break from the inside. All units are checked for any damages before they are released.

No claims can be made against this warranty for lost product.

What Is Not Covered By This Warranty

Spoilage of Product - No claims can be made against this warranty for any spoilage of products, such as food, loss of sales, or consequential damages. BLUE AIR is not responsible for the repair or replacement of any parts that BLUE AIR determines have been subjected after the date of manufacture to alteration, neglect, abuse, misuse, accidents, damage during transit or installation, fire, flood, or acts of God.

Warranty Is Non Transferable - This warranty is not assignable and applies only to the original purchaser/user to whom delivered. Any such assignment or transfer will void this warranty and all other warranties implied.

Improper Usage - BLUEAIR is not liable in any way for parts or labor coverage for component failure or other damages resulting from improper usage or installation or failure to clean and/or maintain product as mentioned in the warranty packet provided with the unit.

Outside U.S. (Including Alaska) - This warranty does not apply to, and BLUE AIR is not responsible for, any warranty claims made on products sold or used outside the United States.

Improper Electrical Connections - BLUE AIR is not responsible for the repair or replacement of failed or damaged components resulting from electrical power failure, the use of extension cords, low voltage, or voltage interference to the unit.

No Implied Warranty of Merchantability or Fitness for a Particular Purpose - There are no other warranties, expressed, implied or statutory, except parts and labor warranty and compressor warranty as described above. These warranties are exclusive and in lieu of all other warranties, including implied warranty and merchantability or fitness for a particular purpose. There are no warranties, which extend beyond this mentioned description.

Remote Condensers - BLUE AIR warrants the original purchaser of the remote cabinet one year parts and labor coverage for all cabinet parts thereof to be free from defects in material or workmanship, under proper use and maintenance service, as specified by BLUE AIR. This warranty is limited to the cabinet only. BLUE AIR is not liable for remote condensing units.

BLUE AIR Commercial Refrigeration Inc.
223 W. Rosecrans Ave, Gardena, CA 90248
Phone: (866-677-8500), (310-808-0102),
Fax:(310) 808-0242
Email: info@blueairinc.com

MEMO

Warranty Registration Card

Blue Air Commercial Refrigeration Inc.
223 W. Rosecrans Ave. Gardena, CA 90248
Tel, 310-808-0102, Fax, 310-808-0242

Customer Name _____

Business Name _____

Telephone : () _____

Telephone : () _____

Address (Customer)

Address (Business or Installation Site)

Street

Street

City

State

Zip

City

State

Zip

Place of Purchase _____

Date Purchased _____ **Date Installed** _____

Model Name _____

Product Serial No. _____

Extended Warranty Option

Additional 1 Year Parts & Labor extended Warranty available
If you are interested, please contact Blue Air Customer Service Dept.

Yes, I would like the extended warranty. / No, I would not like the extended warranty.

Signature of Business Owner _____

Date _____

** The Warranty becomes void if the attached warranty card is not filled out and returned to Blue Air within 15 days from the purchase date.*

Cut along dotted line and mail it back to ; BLUE AIR Customer Service Dept 223 W. Rosecrans Ave. Gardena, CA 90248

*** The Warranty becomes void if the attached warranty card is not filled out and returned to Blue Air within 15 days from the purchase date.**

Cut along dotted line and mail it back to ;

BLUE AIR Customer Service Dept.
223 W. Rosecrans Ave. Gardena, CA 90248

BLUE AIR

223W. Rosecrans Ave. Gardena, CA 90248

TEL, (310) 808-0102

Fax, (310) 808-0242/0262

Toll Free, 1-866-677-8500

Visit us our website at www.blueairinc.com