



# **BLT/BLP-E Series**

## **ELECTRIC BRAISING PAN**

### **INSTALLATION - OPERATION - MAINTENANCE**



**BLODGETT OVEN COMPANY**

[www.blodgett.com](http://www.blodgett.com)  
44 Lakeside Avenue, Burlington, Vermont 05401 USA  
Manufacture Service Questions: 866-518-3977

PART NUMBER 170806 REV B (04/11)

**THIS MANUAL MUST BE RETAINED FOR FUTURE REFERENCE. READ, UNDERSTAND AND FOLLOW THE INSTRUCTIONS AND WARNINGS CONTAINED IN THIS MANUAL.**

**FOR YOUR SAFETY**

**DO NOT STORE OR USE GASOLINE OR OTHER FLAMMABLE VAPORS AND LIQUIDS IN THE VICINITY OF THIS OR ANY OTHER APPLIANCE.**

**POST IN A PROMINENT LOCATION**

**INSTRUCTIONS TO BE FOLLOWED IN THE EVENT USER SMELLS GAS. THIS INFORMATION SHALL BE OBTAINED BY CONSULTING YOUR LOCAL GAS SUPPLIER. AS A MINIMUM, TURN OFF THE GAS AND CALL YOUR GAS COMPANY AND YOUR AUTHORIZED SERVICE AGENT. EVACUATE ALL PERSONNEL FROM THE AREA.**

**WARNING**

**IMPROPER INSTALLATION, ADJUSTMENT, ALTERATION, SERVICE OR MAINTENANCE CAN CAUSE PROPERTY DAMAGE, INJURY OR DEATH. READ THE INSTALLATION, OPERATING AND MAINTENANCE INSTRUCTIONS THOROUGHLY BEFORE INSTALLING OR SERVICING THIS EQUIPMENT.**

**NOTIFY CARRIER OF DAMAGE AT ONCE**

**IT IS THE RESPONSIBILITY OF THE CONSIGNEE TO INSPECT THE CONTAINER UPON RECEIPT OF SAME AND TO DETERMINE THE POSSIBILITY OF ANY DAMAGE, INCLUDING CONCEALED DAMAGE. WE SUGGEST THAT IF YOU ARE SUSPICIOUS OF DAMAGE TO MAKE A NOTATION ON THE DELIVERY RECEIPT. IT WILL BE THE RESPONSIBILITY OF THE CONSIGNEE TO FILE A CLAIM WITH THE CARRIER. WE RECOMMEND THAT YOU DO SO AT ONCE.**

# IMPORTANT - READ FIRST - IMPORTANT

- CAUTION:** BE SURE OPERATORS READ, UNDERSTAND AND FOLLOW THE OPERATING INSTRUCTIONS, CAUTIONS, AND SAFETY INSTRUCTIONS IN THIS MANUAL.
- WARNING:** THIS UNIT IS INTENDED FOR USE IN THE COMMERCIAL HEATING, COOKING AND HOLDING OF WATER AND FOOD PRODUCTS, PER THE INSTRUCTIONS CONTAINED IN THIS MANUAL. ANY OTHER USE COULD RESULT IN SERIOUS PERSONAL INJURY OR DAMAGE TO EQUIPMENT AND WILL VOID WARRANTY.
- WARNING:** ELECTRICALLY GROUND THE PAN AT THE TERMINAL PROVIDED. FAILURE TO GROUND UNIT COULD RESULT IN ELECTROCUTION AND DEATH.
- WARNING:** THE BRAISING PAN MUST BE INSTALLED BY PERSONNEL WHO ARE QUALIFIED TO WORK WITH ELECTRICITY. IMPROPER INSTALLATION COULD RESULT IN PERSONAL INJURY OR EQUIPMENT DAMAGE.
- CAUTION:** STAND AWAY FROM HOT WATER OR FOOD PRODUCTS WHILE TILTING THE PAN DIRECT CONTACT COULD RESULT IN SEVERE BURNS.
- WARNING:** WHEN TILTING BRAISING PAN FOR PRODUCT TRANSFER:
- 1) WEAR PROTECTIVE OVEN MITT AND PROTECTIVE APRON.
  - 2) USE CONTAINER DEEP ENOUGH TO CONTAIN AND MINIMIZE SPLASHING.
  - 3) PLACE CONTAINER ON STABLE, FLAT SURFACE, AS CLOSE TO PAN AS POSSIBLE.
  - 4) STAND TO SIDE OF PAN WHILE POURING — NOT DIRECTLY IN POUR PATH OF HOT CONTENTS.
  - 5) RETURN PAN BODY TO LEVEL POSITION AFTER CONTAINER IS FILLED OR TRANSFER IS COMPLETE.
  - 6) DO NOT OVER FILL CONTAINER. AVOID DIRECT SKIN CONTACT WITH HOT CONTAINER AND ITS CONTENTS.
- WARNING:** DO NOT HEAT AN EMPTY PAN FOR MORE THAN FIVE MINUTES AT A SETTING HIGHER THAN 300°F.
- WARNING:** AVOID ANY EXPOSURE TO THE STEAM ESCAPING FROM THE COVER VENT. DIRECT CONTACT COULD RESULT IN SEVERE BURNS
- WARNING:** AVOID ALL DIRECT CONTACT WITH HOT EQUIPMENT SURFACES. DIRECT SKIN CONTACT COULD RESULT IN SEVERE BURNS.
- WARNING:** AVOID ALL DIRECT CONTACT WITH HOT FOOD OR WATER IN THE BRAISING PAN. DIRECT CONTACT COULD RESULT IN SEVERE BURNS.
- WARNING:** IF THE PAN CONTAINS ITEMS IN SAUCE OR MELTED FAT, THEY COULD SLIDE FORWARD SUDDENLY DURING TILTING AND CAUSE HOT LIQUID TO SPLASH OUT.
- WARNING:** USE OF ANY REPLACEMENT PARTS OTHER THAN THOSE SUPPLIED BY THE MANUFACTURER OR ITS AUTHORIZED DISTRIBUTORS VOIDS ALL WARRANTIES AND MAY CAUSE BODILY INJURY OR EQUIPMENT DAMAGE. SERVICE PERFORMED BY OTHER THAN FACTORY AUTHORIZED PERSONNEL WILL VOID ALL WARRANTIES.
- WARNING:** TURN OFF ELECTRIC POWER BEFORE WORKING ON INTERNAL COMPONENTS.
- WARNING:** BEFORE ANY CLEANING OPERATION, TURN THE THERMOSTAT TO “OFF” TO CUT OFF POWER TO THE HEATING ELEMENTS. BEFORE CLEANING ANY PART OTHER THAN THE INSIDE OF THE PAN, DISCONNECT THE ELECTRICAL SUPPLY AT THE CIRCUIT BREAKER OR FUSE BOX.

# **IMPORTANT - READ FIRST - IMPORTANT**

- WARNING:** BE CAREFUL TO AVOID CONTACT WITH CLEANING PRODUCTS IN ACCORDANCE WITH SUPPLIER AND MANUFACTURER RECOMMENDATIONS. MANY CLEANERS ARE HARMFUL TO THE SKIN, EYES, MUCOUS MEMBRANES AND CLOTHING. READ THE WARNINGS AND FOLLOW DIRECTIONS ON THE CLEANER LABEL.
- CAUTION:** NEVER LEAVE A CHLORINE SANITIZER IN CONTACT WITH STAINLESS STEEL FOR LONGER THAN 30 MINUTES. LONGER CONTACT CAN CAUSE CORROSION.
- WARNING:** DO NOT USE ANY FUSE WITH A HIGHER AMP RATING THAN THE RATING SPECIFIED FOR THAT CIRCUIT.
- WARNING:** KEEP WATER AND SOLUTIONS OUT OF CONTROLS AND ELECTRICAL EQUIPMENT. NEVER USE A HIGH PRESSURE HOSE TO CLEAN THE BRAISING PAN.
- WARNING:** BEFORE REPLACING ANY PARTS, DISCONNECT THE UNIT FROM THE ELECTRIC POWER SUPPLY.
- IMPORTANT:** SERVICE PERFORMED BY OTHER THAN FACTORY AUTHORIZED PERSONNEL WILL VOID WARRANTIES.

# Table of Contents

Important Operator Warnings .....	page 1-2
References.....	page 3
Equipment Description.....	page 4-5
Inspection and Unpacking .....	page 6
Installation .....	page 7-8
Initial Start-Up.....	page 8
Operation .....	page 9-10
Sequence of Operation .....	page 11
Cleaning.....	page 12-13
Maintenance.....	page 14
Troubleshooting.....	page 15
Parts Lists .....	page 16-22
Schematics/Wiring Diagram .....	page 23-26
Service Log .....	page 27-28

## References

NATIONAL FIRE PROTECTION ASSOCIATION  
60 Battery March Park  
Quincy, Massachusetts 02269

NFPA/70 - The National Electrical Code

NSF INTERNATIONAL  
789 N. Dixboro Road  
P.O. Box 130140  
Ann Arbor, Michigan 48113-0140

NSF/ANSI - Standard 4

UNDERWRITERS LABORATORIES, INC.  
333 Pfingsten Road  
Northbrook, Illinois [60062](#)

UL/ANSI - Standard 197

# Equipment Description

The BLT/BLP is a stainless steel, electrically heated Braising Pan which is equipped with integrated heating elements, a hand operated or motor powered tilting mechanism, electrical controls and a hinged cover. The Braising Pan serves as a braising unit, griddle, fry pan, oven, kettle, bain-marie, or food warmer and server. It can also be adapted for use as a non-pressure steamer.

The pan body is constructed of heavy-duty stainless steel, welded into a solid piece. It has a polished interior and exterior finish. A pouring lip is welded to the top of the front wall. The cooking surface is a stainless steel clad plate fitted with clamped-on electrical heating elements. The elements are positioned to ensure uniform heat transfer over the entire surface.

Pans are mounted on an open-leg frame which is fabricated from tubular stainless steel.

An easily operated worm and gear mechanism tilts the pan body and provides precise control for pouring or dumping its contents.

This tilting mechanism is located in a stainless steel console to right of the pan body. For power tilt units a three position switch on the front of the control console gives the operator positive, smooth-acting control of tilt. To facilitate cleaning, the pan body can be tilted past the vertical position.

Heating elements and other electrical components are enclosed for safety. The thermostat, heating indicator light and tilting switch are contained in a compact control console which is mounted to the right of the pan body.

The thermostat provides automatic control of cooking temperature. Turning the thermostat dial starts and stops heating and sets the pan temperature. Only one electrical connection is required to install the unit.

A vented, heavy gauge, one-piece, stainless steel cover with a rear condensate drip shield on the underside is standard on the braising pan. A fully enclosed torsion bar-type counter-balance provides easy operation to open the cover to maintain it open at any position. The cover opens to the back. It is hinged to the frame, so it moves independently from the pan body.

The following sizes and options are available:

Model	PAN DIMENSIONS (inside)			Tilt
	Left to Right	Front to Rear	Depth	
30E-BLT	26-1/4 (667 mm)	28-1/4" (718 mm)	10" (25 mm)	Manual
40E-BLT	35-3/4 (908 mm)	28-1/4" (718 mm)	10" (25 mm)	Manual
30E-BLP	26-1/4" (667 mm)	28-1/4" (718 mm)	10" (25 mm)	Power
40E-BLP	35-3/4" (908 mm)	28-1/4" (718 mm)	10" (25 mm)	Power

# Equipment Description



Optional Tangent Draw-off

The following optional equipment may be added to any floor model listed above:

1. Fill faucet - swing spout single or double pantry
2. Fill faucet - 48" or 60" spray hose assembly - single or double pantry
3. Caster mounting kit
4. Flanged Feet Kit
5. Draw-Off Valve (can not be field installed)
6. Steamer insert set
7. Steamer pan carrier
8. Pouring Lip Strainer
9. Strainer for 2" TDO valve

# Inspection & Unpacking

**CAUTION**  
SHIPPING STRAPS ARE UNDER TENSION  
AND CAN SNAP BACK WHEN CUT.

**CAUTION**  
UNIT WEIGHS 420 TO 560 LB (190 TO 255  
KG). FOR SAFE HANDLING, INSTALLER  
SHOULD OBTAIN HELP AS NEEDED, OR  
EMPLOY APPROPRIATE MATERIALS  
HANDLING EQUIPMENT (SUCH AS A  
FORKLIFT, DOLLY, OR PALLET JACK) TO  
REMOVE THE UNIT FROM THE SKID AND  
MOVE IT TO THE PLACE OF INSTALLATION.

The unit is strapped to a skid, and shipped in a heavy cardboard carton. (Shown is a 40-gallon model with optional right side mounted, double pantry faucet assembly.)

The unit will arrive completely assembled, wrapped in protective plastic on a heavy skid, in a heavy cardboard carton. Immediately upon receipt, inspect the carton for damage. Report any apparent shipping damage or an incorrect shipment to the delivery agent.

When installation is to begin, get someone to assist in removing the carton. Lift it straight up and away from the unit. Do not simply raise it and push backwards - it will break the cover assembly vent handle. Write down the model number, serial number, and installation date of your unit, and keep this information for future reference. Space for these entries is provided at the top of the Service Log in this manual.

Cut the straps holding the unit on the skid, and lift the unit straight up off the skid.

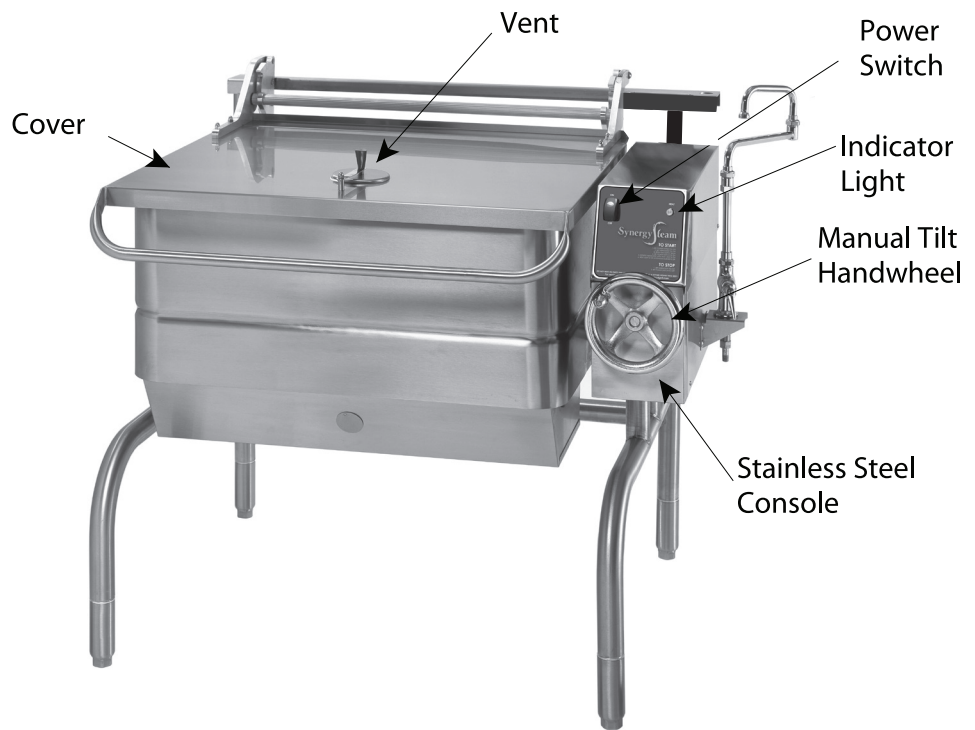

# Installation

**CAUTION**  
BEFORE ANY ELECTRICAL CONVERSION, VERIFY THAT THE BRANCH CIRCUIT WIRING IS ADEQUATE TO HANDLE ANY INCREASE IN AMPERAGE REQUIREMENTS. REFER TO THE ELECTRICAL SPECIFICATIONS LISTED BELOW.

**WARNING**  
INSTALLATION OF THE BRAISING PAN MUST BE DONE BY PERSONNEL QUALIFIED TO WORK WITH ELECTRICITY. IMPROPER INSTALLATION CAN RESULT IN INJURY TO PERSONNEL AND/OR DAMAGE TO EQUIPMENT.



Electronic spark ignition

Internal wiring for the Braising Pan is supplied complete. When you receive the unit, it is ready for connection. A wiring diagram is located inside the control box on the right side of the pan, as well as in this manual.

Your pan was performance-tested at the factory to confirm that all controls and heating elements were functioning correctly.

Installation is as follows:

1. Set the unit in place and level it by turning the adjustable feet. Crank the pan body to a completely horizontal position. Check levelness by placing a spirit level on the bottom of the pan. The unit must be level to avoid uneven cooking across the pan.
2. Make a waterproof connection with the incoming power line at the electrical service entrance at the bottom of the connection box at rear of control console. A BX connection is NOT recommended. **ELECTRICALLY GROUND THE UNIT** at the proper terminal.
3. Provide the proper electrical supply as specified on the electrical information plate. Comply with local codes and the National Electrical Code ANSI/NFPA 7- latest edition.
4. Use only copper wire, rated at least 75°C and of proper gage. See chart below.
5. Standard equipment is shipped ready for 208V, 240V, or 480V, 3-phase operation. Refer to the wiring diagram located on the inside cover of the control box and the instructions below for conversion to single-phase operation.

A jumper wire and “conversion” label are included with the unit. They can be found in a plastic bag attached to the trunnion assembly inside the control box.

## Electrical Requirements

**Note: Use only copper wire rated for 75°C or higher**

Model	Power	208 Volt, Single Phase		240 Volt, Single Phase		208 Volt, 3-Phase		240 Volt, 3-Phase		400 Volt, 3-Phase, 4 Wire		480 Volt, 3-Phase	
	Kw	Amps	Wire (AWG)	Amps	Wire (AWG)	Amps	Wire (AWG)	Amps	Wire (AWG)	Amps	Wire (AWG)	Amps	Wire (AWG)
30E-BLT	11.5	56	6	48	6	32	8	28	10	17	14	14	14
30E-BLP	11.5	56	6	48	6	32	8	28	10	17	14	14	14
40E-BLT	15.3	74	4	64	4	43	8	37	8	22.5	12	19	14
40E-BLP	15.3	74	4	64	4	43	8	37	8	22.5	12	19	14

# Installation

6. For conversion from 3-phase to 1-phase
  - a. Verify that the branch circuit wiring is adequate for any increased amperage requirements. (See table on previous page)
  - b. 1-phase requires two jumper wires. One jumper wire exists on the terminal block for 3- phase input. The second jumper wire is located in a plastic bag inside the control box.
  - c. Attach jumper wires to terminal block as per wiring diagram for 1 phase supply.
  - d. Complete “conversion label” (supplied in bag) and adhere it to the control box near the UL data plate.

# Initial Start-Up

**WARNING**  
**WATER IS EXTREMELY HOT AND CAN CAUSE SEVERE BURNS. AVOID CONTACT WITH HOT WATER WHEN EMPTYING UNIT.**

Now that your braising pan has been installed, you should test it to ensure that the unit is operating correctly.

1. Remove all literature and packing materials from the interior and exterior of the unit.
2. Turn on the electrical power to the unit.
3. Put enough water into the pan to cover its bottom to a depth of 1/4” to 1/2” (6 to 13 mm). With the pan body in the horizontal position, note how the water covers the pan bottom. This is a good method to use for confirming that the unit is properly leveled.
4. Set the thermostat to 235°F. The heating indicator light should come on to show that the pan is heating. Heating should continue until the water boils.
5. To shut the unit down, turn the thermostat dial to “OFF.”
6. Turn the tilting handwheel clockwise to pour out the water and to confirm that the pan body can be tilted smoothly from horizontal to vertical. For power tilt models, push the UP/DOWN switch to confirm operation of tilting system.

If the unit functions as described above, it is ready for use. If it does not, contact your local Authorized Service Agency.

# Operation

**WARNING**  
KEEP THE AREA AROUND BRAISING PAN  
FREE AND CLEAR OF COMBUSTIBLE  
MATERIALS.

**CAUTION**  
KEEP FLOORS IN BRAISING PAN WORK  
AREA CLEAN AND DRY. IF SPILLS OCCUR,  
CLEAN IMMEDIATELY TO AVOID THE  
DANGER OF SLIPS OR FALLS.

**CAUTION**  
REPLACE THE HOLE PLUG BEFORE  
CLEANING OTHERWISE WATER COULD  
ENTER THE ELECTRICAL CONTROL BOX  
AND DAMAGE THE PARTS.

**WARNING**  
WHEN TILTING BRAISING PAN  
FOR PRODUCT TRANSFER:

- 1) USE CONTAINERS DEEP ENOUGH TO CONTAIN AND MINIMIZE PRODUCT SPLASHING.
- 2) PLACE CONTAINER ON A STABLE, FLAT SURFACE, AS CLOSE TO THE BRAISING PAN AS POSSIBLE.
- 3) STAND TO THE SIDE OF THE PAN WHILE POURING — NOT DIRECTLY IN THE POUR PATH OF HOT CONTENTS.
- 4) RETURN PAN BODY TO UPRIGHT POSITION AFTER CONTAINER IS FILLED OR TRANSFER IS COMPLETE.
- 5) DO NOT OVERFILL CONTAINER. AVOID DIRECT SKIN CONTACT WITH HOT CONTAINER AND CONTENTS.

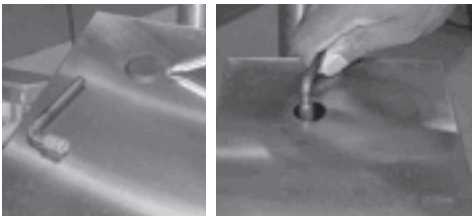

Tilting pan body

## A. Controls

Operator controls for the braising pans are:

1. Power ON Switch and Power ON indicator located on the control console.
2. The thermostat dial, located on the control console to the right of the pan body. This dial is used to turn the thermostat on or off and to set the thermostat for pan temperatures between 175° and 400°.
3. Heating indicator light located on the control console, lights when the burners have ignited.
4. A handwheel controls the worm and gear mechanism that smoothly tilts the pan body and holds it in the desired position.
5. For power tilt units a switch is located on the control panel. It is used to raise and lower the pan body.

## B. Operating Procedure

1. To Tilt Pan Body
  - a. Manual Tilt Model -  
Turn the tilting handwheel clockwise to tilt the pan body, or counterclockwise to return the pan body to horizontal. 23 complete turns of the handwheel will tilt the body 90 degrees to vertical.
  - b. Power Tilt Model -
    1. Press the power tilt switch marked “up” to raise the pan or “down” to lower the pan.
    2. The spring loaded switch will return to the OFF (middle) position when you release it.
    3. If the power tilt mechanism stops working (see the Troubleshooting section) and you must raise or lower the pan body without delay, you can tilt the body by hand. Remove the small plug on top of the control box and fit the provided tool into the hole. Turn the tool clockwise to lower it. It may take several minutes to move the pan to the desired position, but the operation can be speeded up by substituting a reversible drill with a 1/4” hexagonal driver bit in place of the tool.
2. Set the thermostat dial to the desired temperature between 100 and 400°F. The Heat Indicator Light shows that the pan is heating. When the light cycles on and off, it indicates that the pan is holding at the set temperature. During these cycles you may hear the contactors in the control box make a clicking sound. This is normal.
3. For best results when braising or frying, preheat the pan before putting in any food. For an even temperature across the pan, preheat at a setting of 300°F or less for 15 minutes, or through several on/off cycles of the thermostat.

# Operation

## CAUTION

DO NOT HEAT AN EMPTY PAN FOR MORE THAN FIVE MINUTES AT A SETTING HIGHER THAN 300°F. DAMAGE TO THE PAN COULD RESULT.

## CAUTION

DO NOT OVERFILL THE BRAISING PAN WHEN COOKING, HOLDING OR CLEANING. KEEP LIQUIDS AT LEAST 2-3" (5-8 cm) BELOW THE PAN BODY RIM TO ALLOW CLEARANCE FOR STIRRING, BOILING PRODUCT AND SAFE TRANSFER.

## WARNING

AVOID ANY EXPOSURE TO THE STEAM ESCAPING FROM THE COVER VENT. DIRECT CONTACT COULD RESULT IN SEVERE BURNS.

## WARNING

ITEMS IN SAUCE OR MELTED FAT CAN SLIDE FORWARD SUDDENLY DURING TILTING AND SPLASH THE HOT LIQUID.

## WARNING

AVOID ALL DIRECT CONTACT WITH HOT EQUIPMENT SURFACES. DIRECT SKIN CONTACT COULD RESULT IN SEVERE BURNS. AVOID ALL DIRECT CONTACT WITH HOT FOOD OR WATER IN THE BRAISING PAN. DIRECT CONTACT COULD RESULT IN SEVERE BURNS.



## C. Cooking

1. To simmer or slowly heat an item, set the dial at 210°F or lower. Put the cover down to minimize moisture loss, or leave it up to help dry or reduce the product. Set the thermostat higher to cook or drive off moisture faster. You may adjust the thermostat to any setting to cook the item exactly as required.
2. Leave the cover vent open to let excess steam escape. For long simmering operations, you may wish to close the vent to retain moisture.
3. To check progress when the cover is closed, lift the handle of the vent cover slightly, and move it quickly to either side.
4. Standing to one side of the pan (to avoid the steam that will be released) grasp the nearer corner of the cover handle and raise the cover. The cover will stay in the open position until you push it down.
5. To pour product, remove grease, or assist in cleaning, first raise the cover, then tilt the pan forward by turning the tilting handwheel. When you stop turning the wheel, the pan body will hold its position.
6. To return the pan to the horizontal position, turn the wheel counter-clockwise.
7. To turn the pan off, turn the thermostat to the "OFF" position.

## D. Routine Clean-Up

After each use, turn the thermostat to "OFF" and clean all food contact surfaces to ensure proper sanitation. At the end of the day, or at least once every 24 hours, turn off the heat and shut off electric power to the unit and clean both the interior and exterior of the pan. See Page 12 for more detailed cleaning instructions.

# Sequence of Operation

The following “action-reaction” outline is provided to help you understand how the braising pan actually functions.

When you start up the pan by turning the thermostat from “OFF” to a desired temperature, the thermostat switch closes. This causes the contactors to close, and allows power to flow to the heating elements and the indicator light.

When the pan temperature reaches the value set on the thermostat dial, the thermostat switch opens and causes the contactors to open. This stops the flow of power to the heating elements and the indicator light. As soon as the thermostat senses that the pan is cooling below the set temperature, the thermostat closes, the contactors close, and the heaters and indicator light come on again.

This on and off cycle continues, maintaining the pan at the set temperature. This is why the indicator light on and off cycling is seen during normal operation. If the pan temperature exceeds 425°F for any reason, a high-limit thermostat shuts off the power until the pan cools. At that point, the thermostat automatically resets to permit normal operation to start again.

Turning the thermostat to “OFF” shuts down all control and heating circuits.

The thermostat controls heating by alternating between feeding full power and completely cutting power off. The pan heats as fast as it can until it reaches the set temperature, no matter what that temperature is. Turning the thermostat to a higher setting will cause heating to continue longer, until the pan reaches a higher temperature, but it cannot make the pan heat any faster.

Manual tilt models, turning the hand wheel rotates a worm, which turns a gear wheel on one of the trunnions supporting the pan body. Turning the gear produces the tilting action.

Power tilt models, pushing the up/down switch operates a gear motor which turns worm and gear wheel as described above.

For all braising pans, the power to the heaters is cut off when the pan is tilted past a slight inclination of 10° degrees. It is acceptable to cook with the pan tilted forward at a small angle (about 5 - 7 degrees) to let liquids collect to front of pan or allow them to drain out of the draw off valve.

# Cleaning

## WARNING

KEEP WATER AND SOLUTIONS OUT OF CONTROLS AND ELECTRICAL EQUIPMENT. DO NOT USE A HIGH PRESSURE HOSE TO CLEAN THE CONTROL CONSOLE, ELECTRICAL CONNECTIONS, ETC.

## CAUTION

MOST CLEANERS ARE HARMFUL TO THE SKIN, EYES, MUCOUS MEMBRANES AND CLOTHING. PRECAUTIONS SHOULD BE TAKEN TO WEAR RUBBER GLOVES, GOGGLES OR FACE SHIELD AND PROTECTIVE CLOTHING. CAREFULLY READ THE WARNINGS AND FOLLOW THE DIRECTIONS ON THE LABEL OF THE CLEANER TO BE USED.

## WARNING

BEFORE ANY CLEANING OPERATION, TURN THERMOSTAT DIAL TO "OFF" TO CUT ANY POWER TO THE HEATING ELEMENTS. BEFORE CLEANING ANY PART OTHER THAN THE INSIDE OF THE PAN, DISCONNECT ELECTRICAL SUPPLY AT CIRCUIT BREAKER OR FUSE BOX.



Use a brush, sponge, cloth, plastic or rubber scraper, or plastic wool to clean.



Don't use metal implements or steel wool.



Do not spray water directly on burners and gas combustion chambers.

## A. Suggested Tools

1. A good stainless steel cleaner
2. Brushes in good condition
3. Cloth for cleaning controls
4. Chlorine sanitizer
5. Heavy Duty Cleaner (if required)

## B. Procedure

1. Clean all food-contact surfaces soon after use. It is best to clean the pan before it has completely cooled. If the unit is in continuous use, completely clean and sanitize both the inside and outside at least once every 12 hours.
2. To remove any large amount of food left in the pan, tilt the pan all the way up and flush it with lukewarm water. Do not damage the surface of the pan by scraping it with a metal tool. Scratches make the surface more difficult to clean, and provide ideal breeding places for bacteria.
3. Following the supplier's directions, make up a warm solution of the cleaner. Carefully wash the inside and outside of the pan body with the cleaning solution.
4. Use a cloth moistened with cleaning solution to clean controls, the control console, and electric conduit.
5. Rinse the pan very well with lukewarm water, and drain it completely.
6. As part of the daily cleaning program, clean all inside and outside surfaces that may have been soiled. Remember to check such parts as the under-sides of the cover, the electrical console and other more remote spots. Clean between the pan body and the consoles using a brush.
7. Controls and the control console may be cleaned with a damp cloth or sprayed with a garden hose spray connected to city water supply. Do not use a pressure sprayer directly on the unit or electrical parts.
8. To remove materials stuck to the equipment, use a brush, sponge, cloth, plastic or rubber scraper, or plastic wool with the cleaning solution. To make washing easier, let the cleaning solution sit in the unit and soak into the residue, or heat the solution briefly. Do not use any gritty cleaner or metal tool that might scratch the surface. Scratches make the surface harder to clean, and also provide places for bacteria to grow. Do not use steel wool. Small bit of steel wool left in the surface of the unit can cause rusting and pitting.
9. The outside of the unit may be polished with a recognized stainless steel cleaner such as Zepper from the Zep Manufacturing Company.
10. When the equipment needs to be sanitized, use a sanitizing solution equivalent to one that supplies 100 parts per million available chlorine. Get advice about the best sanitizing agent from your supplier of sanitizing products.

# Cleaning

**CAUTION**  
**NEVER LEAVE A CHLORINE SANITIZER IN CONTACT WITH STAINLESS STEEL SURFACES FOR LONGER THAN 30 MINUTES. LONGER CONTACT CAN CAUSE CORROSION.**

**CAUTION**  
**KEEP CAUSTIC COMPOUNDS SUCH AS FRYER BOILOUT CLEANERS AWAY FROM ALUMINUM PARTS OF THE LID HINGE SYSTEM AND THE COUNTERBALANCE ASSEMBLY. HIGHLY CAUSTIC COMPOUNDS COULD DAMAGE THIS MATERIAL.**

11. Following supplier instructions, apply the sanitizing agent after the unit has been cleaned and drained. Thoroughly drain off the sanitizer.
12. After the unit has been cleaned, sanitized and drained, let all surfaces air dry unless the unit must be used again right away.
13. It is recommended that the unit be sanitized just before use. Follow the directions of the sanitizer supplier.
14. About once a week (more often if the water is very hard), use a heavy duty cleaner to remove any mineral deposits or film left by hard water or foods. Follow the supplier's directions very carefully, and rinse the unit off thoroughly, as soon as cleaning is finished.
15. If especially difficult cleaning problems persist, contact your cleaning product supplier for help. The supplier has a trained technical staff with laboratory facilities to serve you.

# Maintenance

**WARNING**  
ELECTRIC POWER ALWAYS SHOULD BE SHUT OFF BEFORE WORK IS DONE ON INTERNAL COMPONENTS.

**WARNING**  
DISCONNECT ELECTRICAL POWER FROM THE UNIT BEFORE ATTEMPTING TO GREASE THE TRUNNION BEARINGS.



Your braising pan is designed to require minimum maintenance, but certain parts may need replacement after prolonged use. After installation, no user adjustment should be necessary. If a service need arises, only authorized personnel should perform the work.

Service personnel should check the unit at least once a year. This periodic maintenance should include inspecting electrical wires and connections, cleaning the inside of the control console, and possible adjustment of the pilot light. (Units with standing pilot ignition only) At least twice a year, grease the two trunnion bearings and worm gear.

We recommend the use of number two grade LGI lithium grease. Add grease through the zerk fittings on the gear hosing until grease flows out of the bearings around trunnion shaft. Also, add grease in the gear to cover arc that is in contact with the worm gear. Clean up excess grease.

A Service Log is provided with the warranty information at the back of this manual. Each time service is performed on your equipment, enter the date on which the work was done, what was done, and who did it. Keep the manual with the equipment for quick and easy reference.

# Troubleshooting

Your braising pan will operate smoothly and efficiently if properly maintained. However, the following is a list of checks to make in the event of a problem. If the actions suggested do not solve the problem, call your qualified Service Representative. If an item on the list is followed by X, the work should only be performed by a qualified service representative.

## WARNING

**ELECTRICAL POWER MUST BE SHUT OFF BEFORE WORK IS DONE ON INTERNAL COMPONENTS.  
USE OF ANY REPLACEMENT PARTS OTHER THAN THOSE SUPPLIED BY THE MANUFACTURER OR THEIR AUTHORIZED DISTRIBUTOR CAN CAUSE INJURY TO THE OPERATOR AND DAMAGE TO THE EQUIPMENT AND WILL VOID ALL WARRANTIES.  
SERVICE PERFORMED BY OTHER THAN FACTORY-AUTHORIZED PERSONNEL WILL VOID ALL WARRANTIES.**

SYMPTOM	WHO	WHAT TO CHECK (X indicates work that should only be performed by a qualified service representative)
Pan will not heat, but indicator light comes on.	Authorized Service Rep Only	a. Heating elements for short circuit. X
Pan will not heat, and indicator light will not light.	User	a. That power supply is on.
	Authorized Service Rep Only	b. Fuses, accessible by removing caps on the side of the control box. c. For loose or broken wires. X d. Thermostat functioning, by listening for a click when the switch opens or closes. X e. Contactor functioning. X
Pan continues to heat after it reaches desired temperature.	User	a. Thermostat dial setting. Turn down if too high.
	Authorized Service Rep Only	b. Thermostat functioning. X c. Thermostat calibration. X d. Contactor, to determine if it is de-energized. X
Pan does not reach desired temperature.	User	a. Thermostat dial setting. Turn up if too low.
	Authorized Service Rep Only	b. Heating elements for ground short or open (burned out) element. X c. Thermostat functioning, by listening for a click when the switch opens or closes. X d. Thermostat calibration. X e. Contactor functioning. X
Rapid clicking noise (chattering).	User	a. For low voltage.
	Authorized Service Rep Only	b. Contactor for dirt or corrosion on the contacts. X
Uneven cooking due to hot spots.	User	a. That the pan body is level.
Uneven cooking due to cold spots.	Authorized Service Rep Only	a. For open (burned out) heating element. X
Pan is hard to tilt (Manual Tilt Models).	User	a. Gears for foreign materials, lubrication and alignment.
Pan will not tilt (Power Tilt Models).	User	a. That electrical power supply is on. b. For overheated actuator motor. Wait 15 minutes for motor to cool, then operate the power tilt.
	Authorized Service Rep Only	c. For blown fuse on motor control circuit - Replace fuse with approved equal. X d. For damaged DC rectifier and operating relays. X e. Correct setting of upper and lower limit switches. X

# Parts List

## Stand & Foot Assembly

Key	Description	Part #
1	CASTER KIT (SET OF 2 WITH BRAKE AND 2 W/O BRAKE)	170810
1	CASTER WITH BRAKE (W/O FOOT ADAPTER)	146513
1	CASTER WITHOUT BRAKE (W/O FOOT ADAPTER) NOT SHOWN	146515
2	FOOT ADAPTER	146516
3	FLANGED FOOT (W/O FOOT ADAPTER)	146521
4	BULLET FOOT (W/O FOOT ADAPTER)	146628
5	FRICTION RING	146520



# Parts List

## Cover & Counterbalance Assemblies

Key	Qty	Description	Part #
1	1	COVER & COUNTERBALANCE ASSEMBLY, 30 GALLON - NO KNOB	158643
1	1	COVER & COUNTERBALANCE ASSEMBLY, 40 GALLON - NO KNOB	158658
3	4	STUD WELD, 1/4"-20 X 1-1/4"	012589
4	4	WASHER, LOCK 3/8"	005618
5	4	SCREW, HEX HEAD CAP 3/8"-16 X 1"	005612
6	4	NUT, HEX 3/8"-16	005619
7	4	DOME NUTS, 1/4-20	090567
8	2	SCREW, TRUSS HEAD, #10-32 X 3/8"	004173
9	1	VENT COVER ASSY.	158642

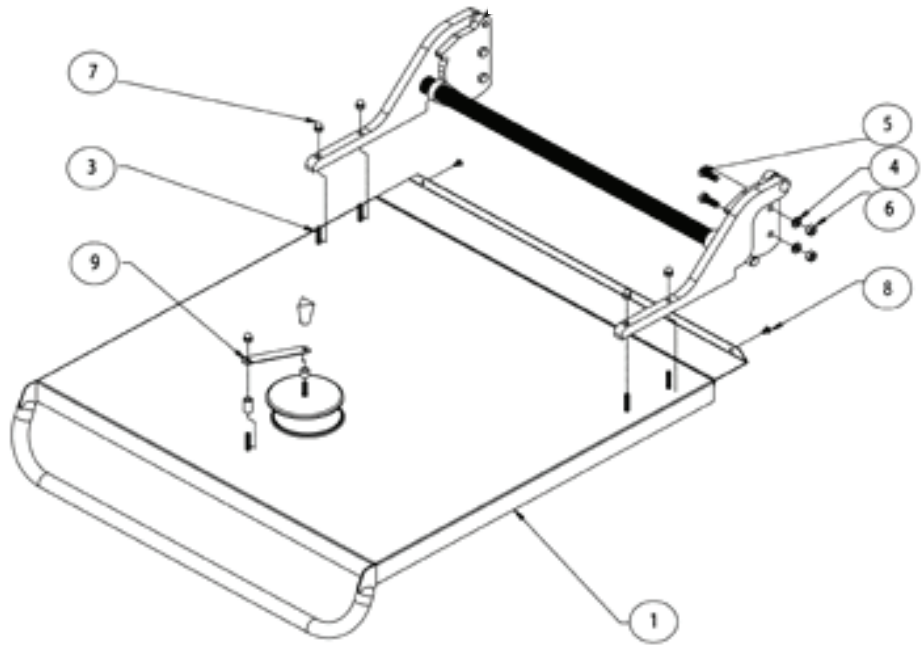

# Parts List

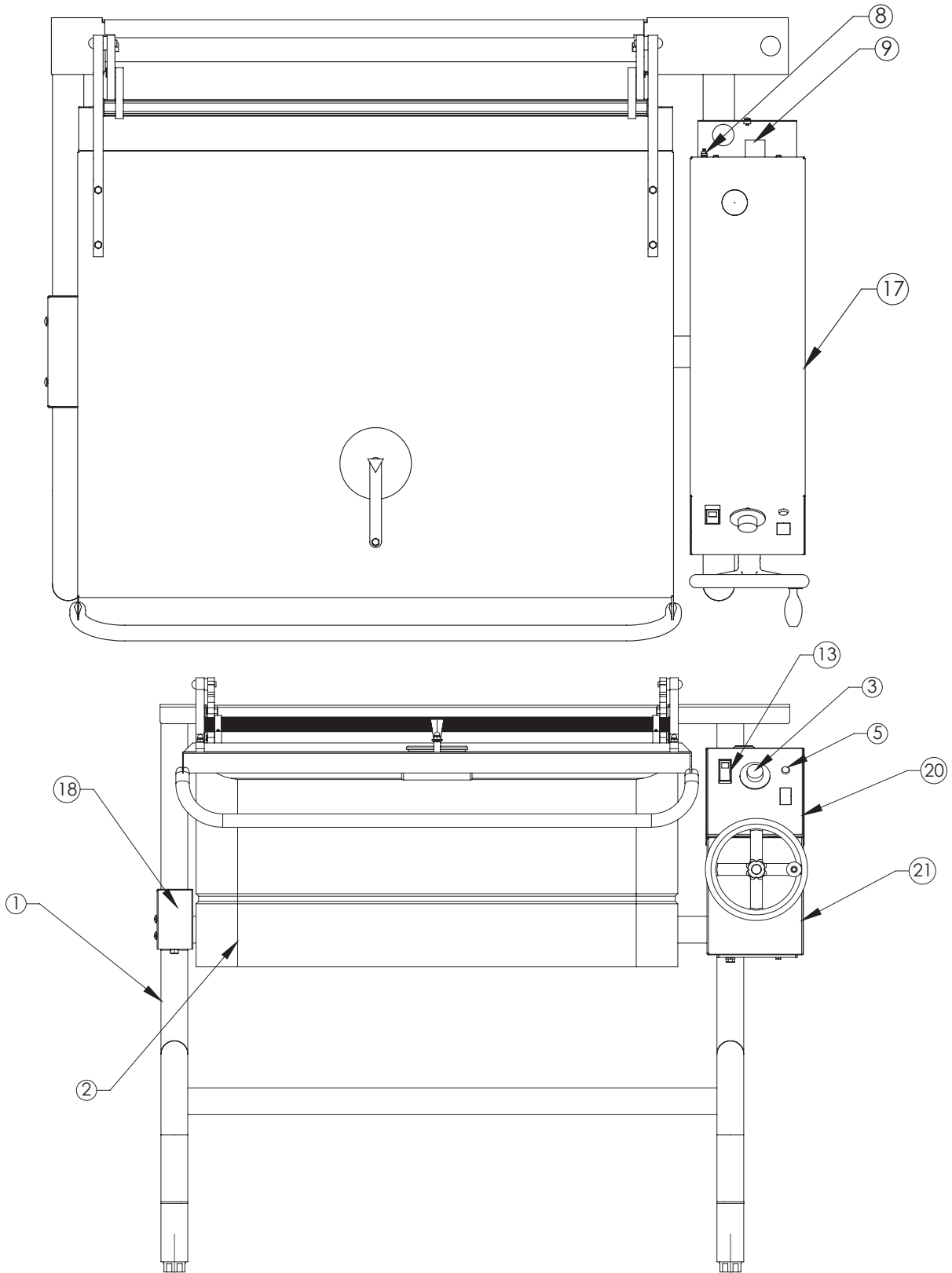

# Parts List

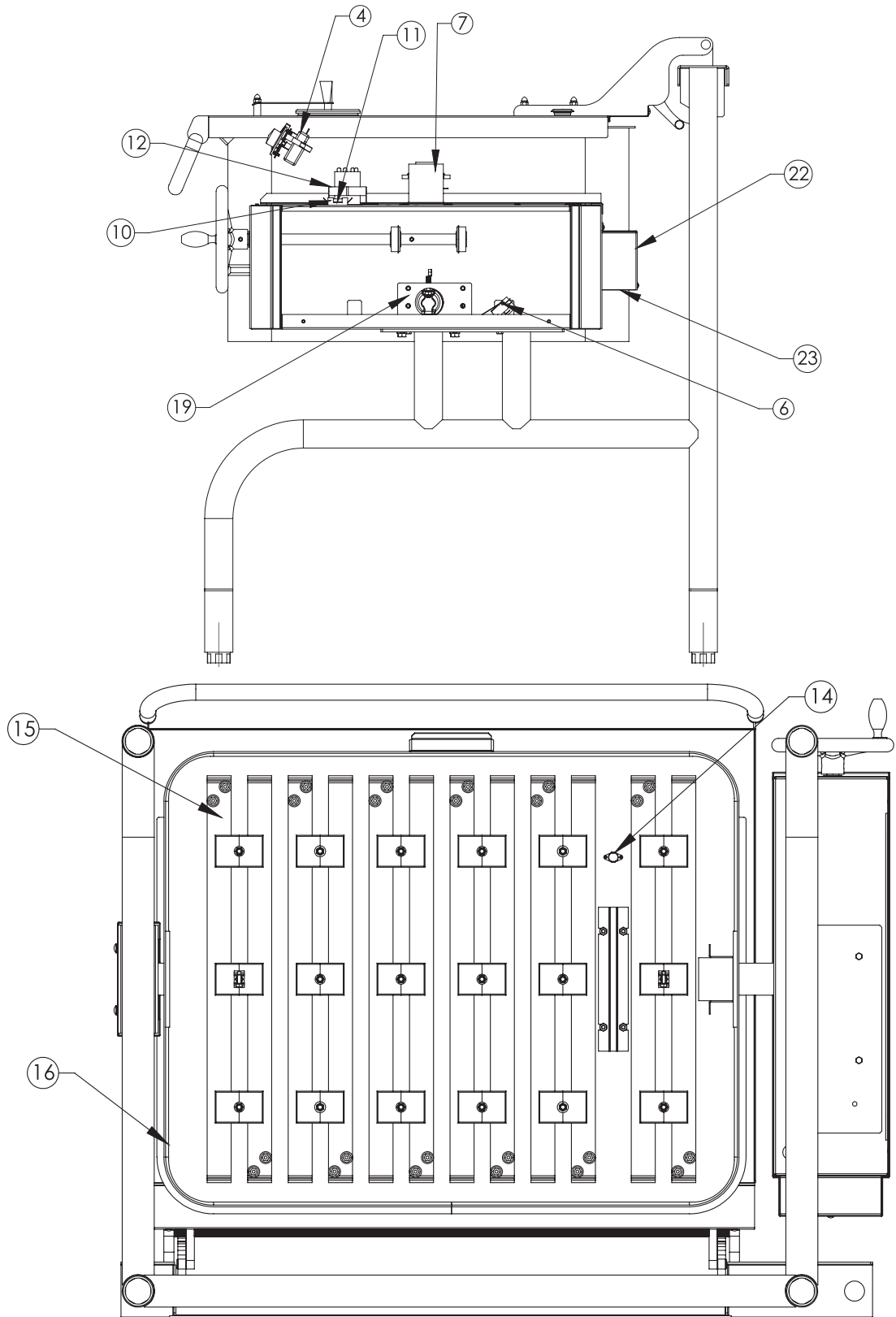

# Parts List

To order parts, contact your Authorized Service Agent. Supply the model designation, serial number, part description, part number, quantity, and when applicable, voltage and phase.

KEY	DESCRIPTION	PART NO.
1	STAND ASSEMBLY - 30	144848
1	STAND ASSEMBLY - 40	144332
2	PAN WELDMENT - 30	145654
2	PAN WELDMENT - 40	144789
3	KNOB THERMOSTAT	003908
4	OPERATING THERMOSTAT	002180
5	LIGHT, AMBER	116384
6	TILT SWITCH	143319
7	CONTACTOR	148102
8	GOUND TERMINAL	119829
9	TERMINAL BLOCK	003888
10	FUSE HOLDER	077854
11	FUSE, 3 AMP	077853
12	TRANSFORMER - 208/240V	137441
12	TRANSFORMER - 480V	137694
13	POWER SWITCH	155546
14	HIGH LIMIT THERMOSTAT	142755
15	ELEMENT - 208V	145656
15	ELEMENT - 240V	146185
15	ELEMENT - 480V	149114
16	COVER ELEMENT HOUSING - 30	146186

KEY	DESCRIPTION	PART NO.
16	COVER ELEMENT HOUSING - 40	144343
17	RIGHT SIDE COVER	145688
18	LEFT TRUNNION COVER ASSEMBLY	144776
19	TILT SWITCH BRACKET ASSEMBLY	145689
20	CONTROL BOX ASSEMBLY	147313
21	ELECTRICAL BOX ASSEMBLY	147315
22	TERMINAL BLOCK BOX	146205
23	TERMINAL BLOCK BOX BOTTOM	146207
x	TRANSFORMER, POWER TILT 480V	051469
x	OVERLAY, MANUAL TILT	170800
x	OVERLAY, POWER TILT	170801
x	HARNESS, CONTROL	148538
x	HARNESS, POWER 208/240V	148539
x	HARNESS, POWER 480V	149291
x	HARNESS, ELEMENTS 30 208/240V	148560
x	HARNESS, ELEMENTS 30 480V	149293
x	HARNESS, ELEMENTS 40 208/240V	148561
x	HARNESS, ELEMENTS 40 480V	149292

x- Item not depicted/called out in drawing or photograph

# Parts List Manual Tilt Assembly

Key	Qty	Description	Part #
1	1	GEAR CARRIER	002624
2	1	SHAFT, HANDWHEEL	144834
3	1	GEAR, WORM	128001
4	1	GEAR SECTOR	009829
5	1	KEY GIB	012031
6	1	HANDWHEEL	139152
7	2	PIN ROLL	012614
8	2	SCREW SET SOCKET	012060
9	2	BEARING ROLLER	002790
10	2	BEARING SLEEVE	137239
11	1	PLUG PIPE	010286
14	1	FITTING GREASE 90 (NOT SHOWN)	012195
15	1	BUSHING SNAP (NOT SHOWN)	000453
16	2	WASHER LOCK	005618
17	2	SCREW HEX HEAD CAP	005612

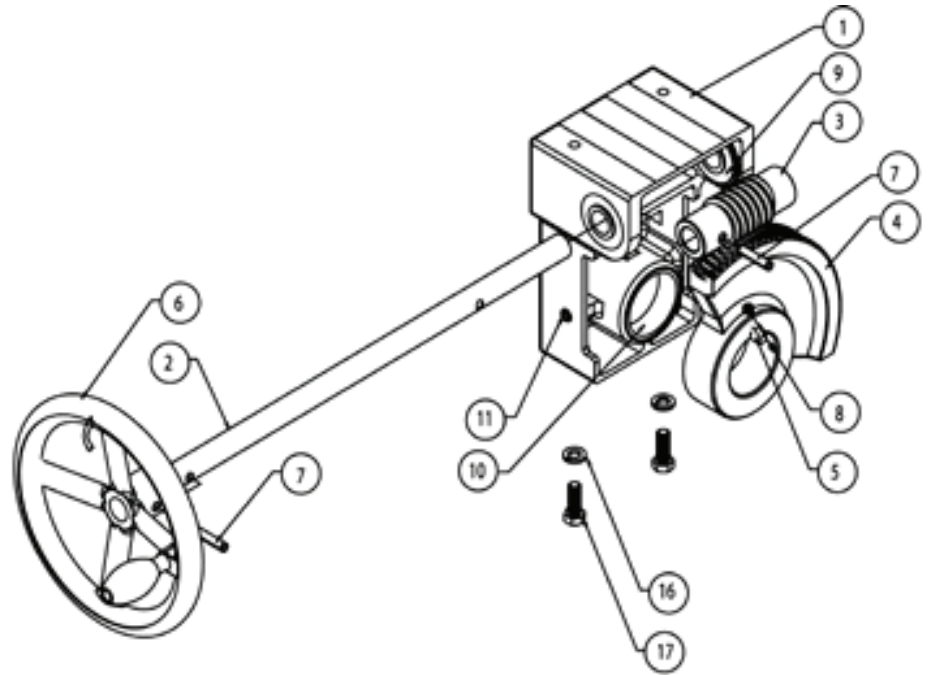

# Parts List

## Power Tilt Assembly

Key	Qty	Description	Part #
1	1	ELECTRIC TILT SHAFT	144791
2	1	POWER LIFT MOTOR [204/240 VOC]	144794
3	1	SHAFT COUPLING	144615
4	1	GEAR CARRIER ASSY	137880
4a	1	CARRIER GEAR	002624
4b	2	BEARING ROLLER	002790
4c	2	BEARING SLEEVE	137239
4d	1	PLUG PIPE	010286
4e	1	FITTING GREASE 90	012195
5	1	GEAR, WORM	128001
6	1	GEAR SECTOR	009829
6a	2	SCREW SET SOCKET	012060
7	1	KEY GIB	012031
8	1	PIN ROLL	012614
9	1	MOTOR BRACKET	146114
10	1	REAR MOTOR BRACKET	146117
11a	1	FUSE HOLDER [MOTOR]	077840
11b	1	FUSE	144856
11c	1	RECTIFIER	145660
11d	2	RELAY [24VAC, DPST, NO]-2 REQ'D	119814
12	5	NUT HEX HEAD 1/4"-20	005601
13	5	WASHER LOCK 1/4"	005655
14	3	SCREW HEX HEAD CAP 1/4"-20 X 2-1/2" LONG	052584
15	2	SCREW HEX HEAD CAP	005609
16	2	WASHER LOCK 3/8"	005618
17	2	SCREW HEX HEAD CAP 3/8"-16 X 1" LONG	005612
18	1	ELECTRIC TILT SHAFT KEY	013386
-	1	HOLE PLUG-1"	146369
-	1	MANUAL OVERRIDE CRANK	145659
-	1	POWER TILT SWITCH, RECESSED ROCKER NO INDICATOR	144857
-	2	TILT LIMIT SWITCH (POWER TILT UP/DN )	002982
-	1	WIRE HARNESS,LOW VOLTAGE	146197
-	1	WIRE HARNESS-HIGH VOLTAGE	148769

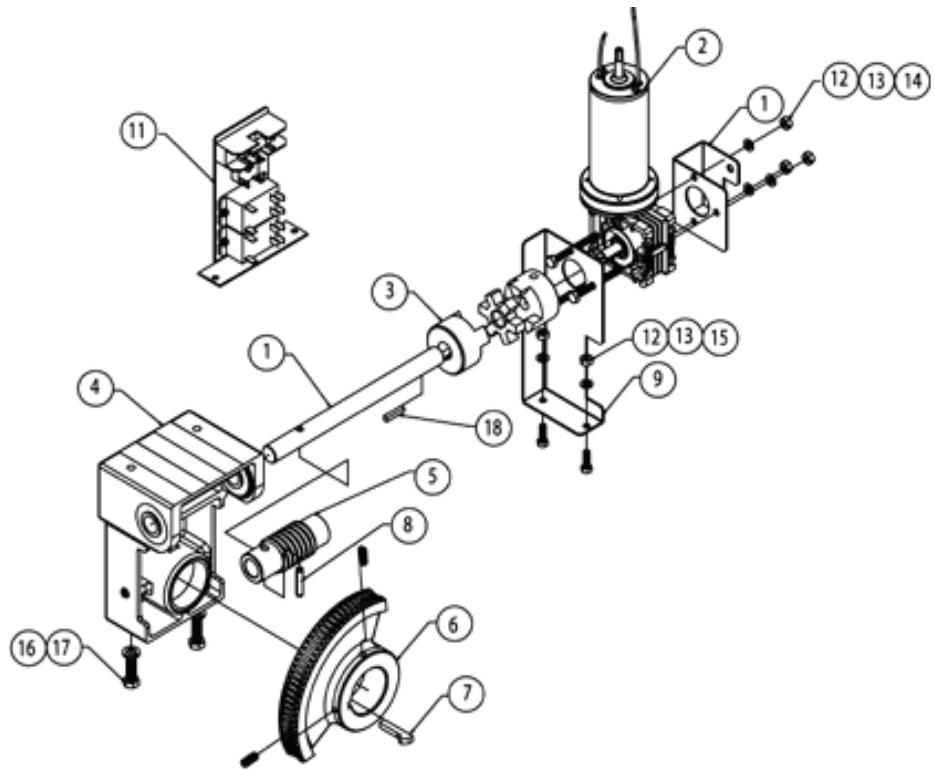

# Schematics 30 Gallon Manual Tilt

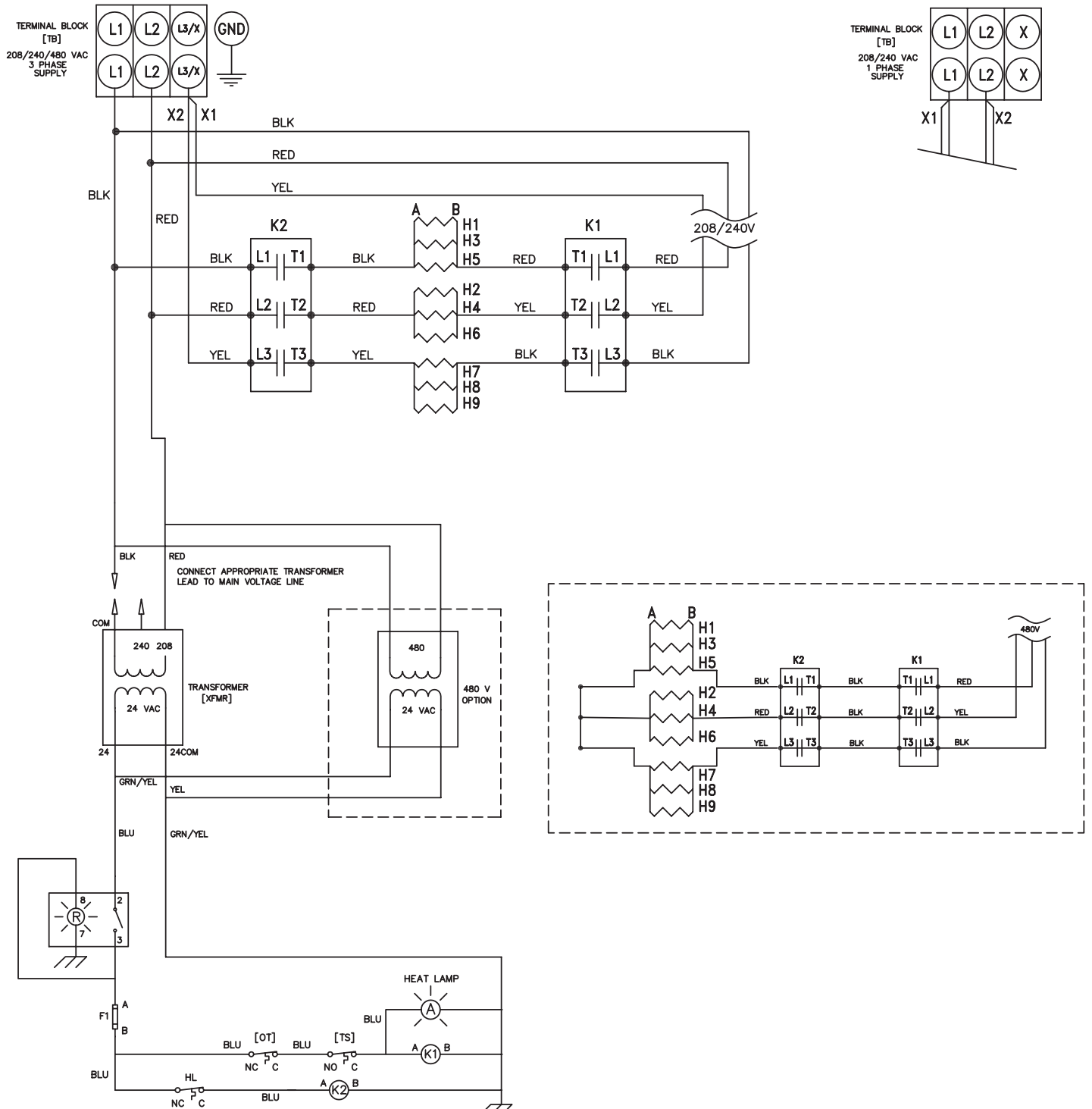

# Schematics

## 30 Gallon Power Tilt

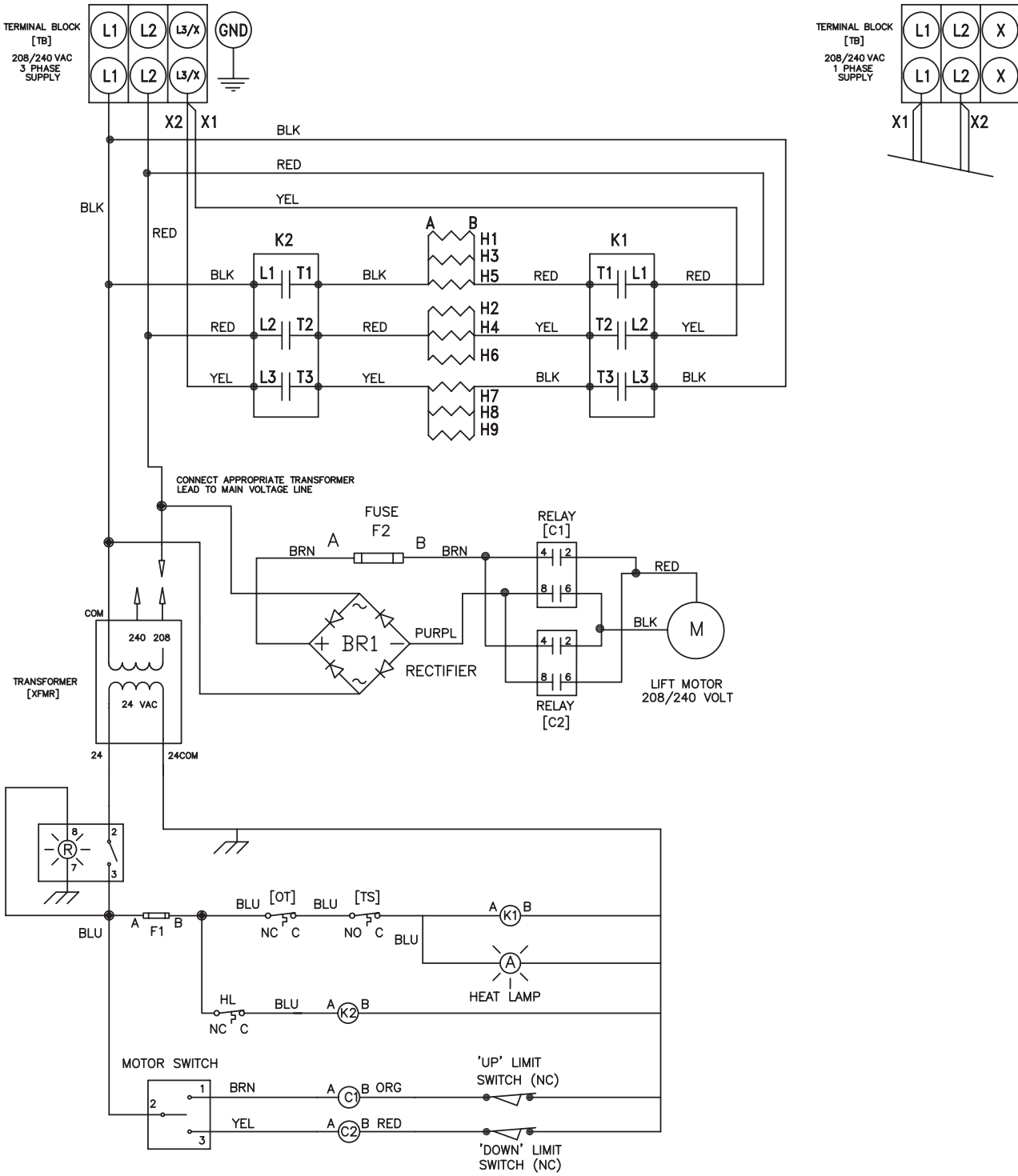

# Schematics 40 Gallon Manual Tilt

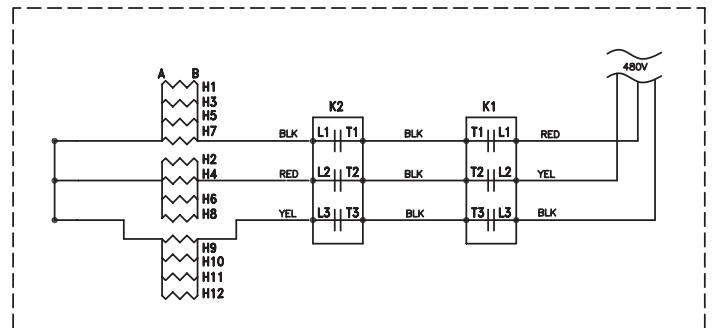
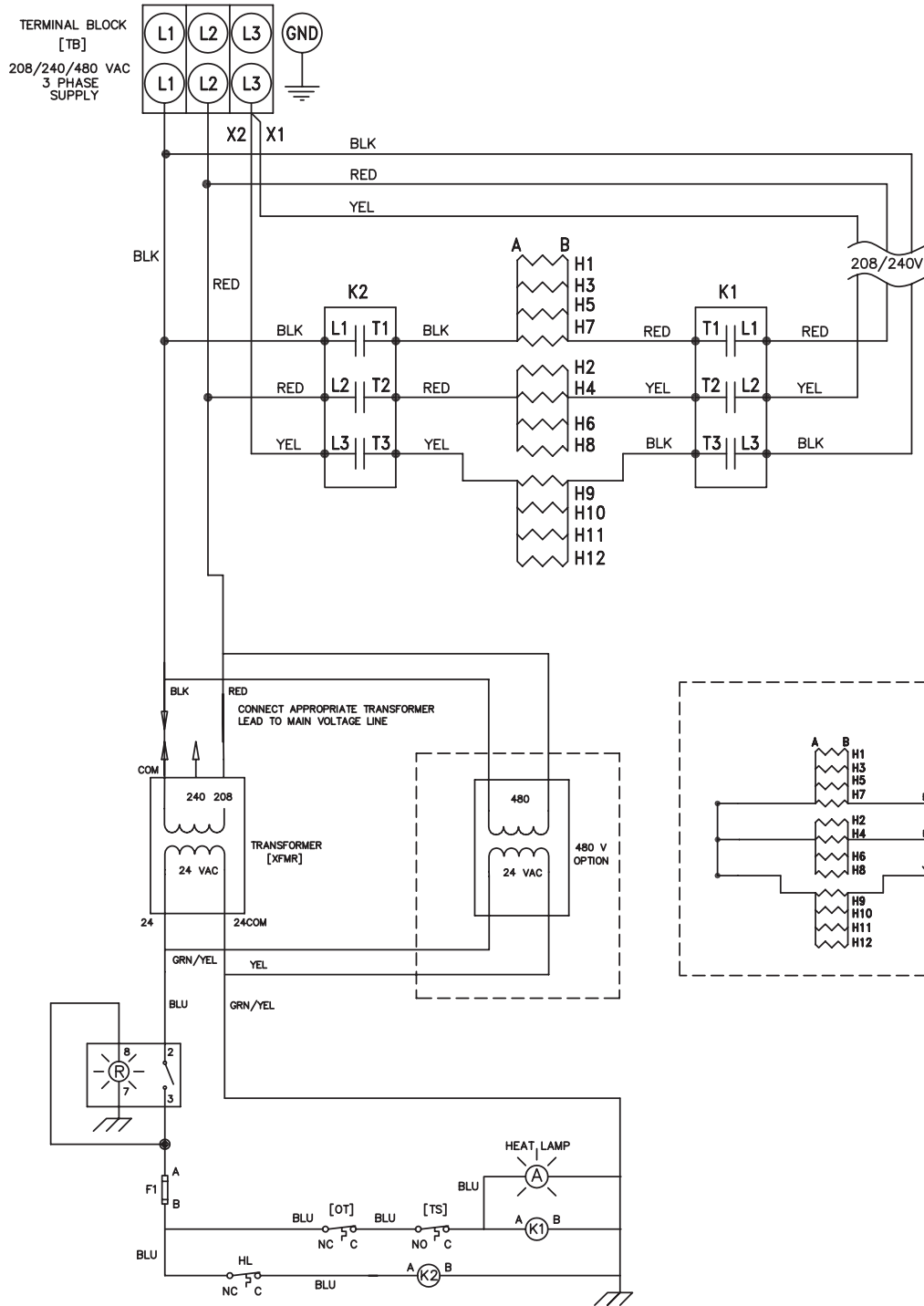

# Schematics

## 40 Gallon Power Tilt

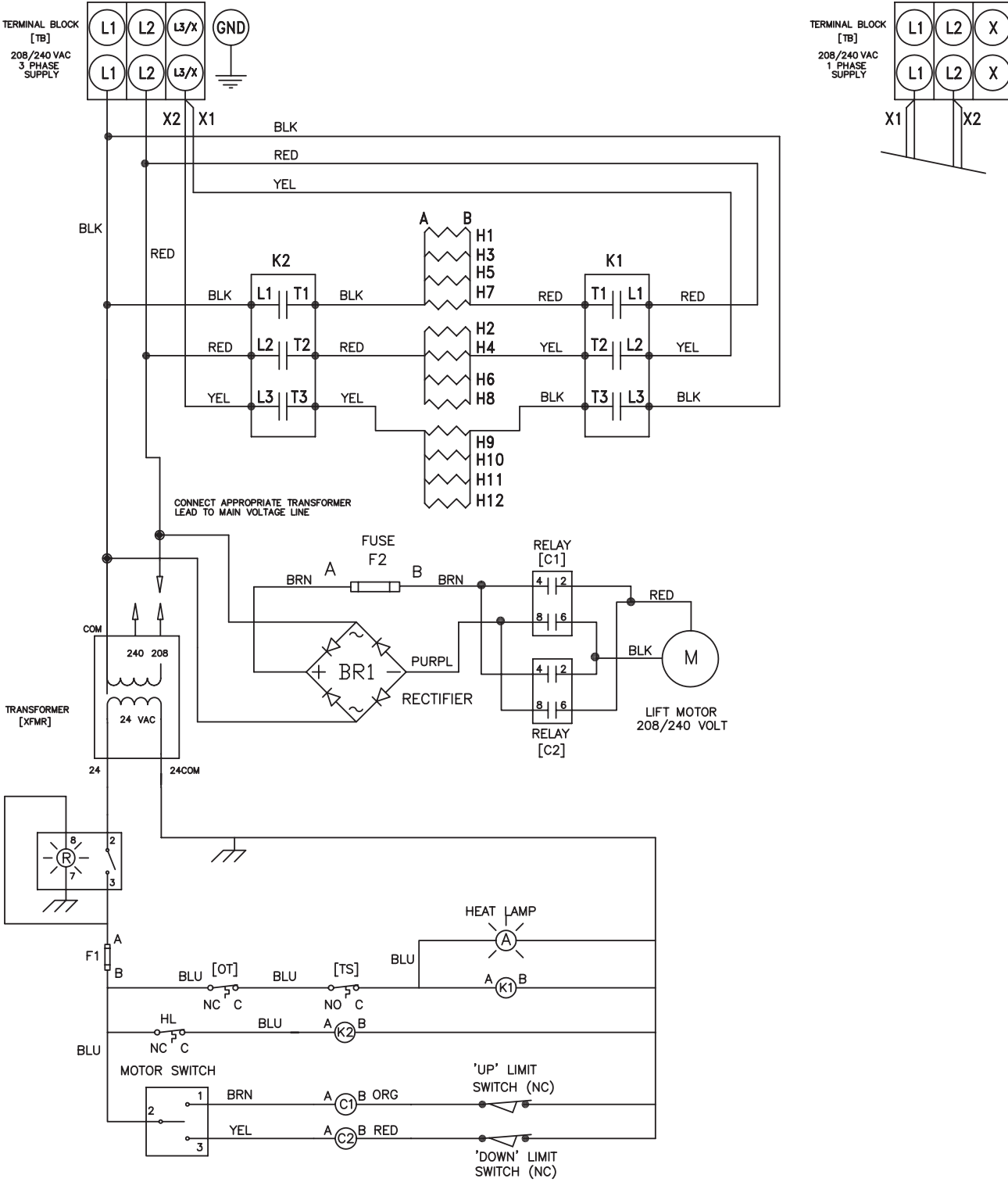









**BLODGETT OVEN COMPANY**

[www.blodgett.com](http://www.blodgett.com)

**44 Lakeside Avenue, Burlington, Vermont 05401 USA  
Telephone: 866-518-3977**