



5925 Heisley Road • Mentor, OH 44060-1833

Insulated Hot Cabinet	FL-2251
Rev. 10 (6/08)	Page 1 of 5

OPERATING and MAINTENANCE INSTRUCTIONS

Models: H137UA...C & H13818...C Series Hot Cabinets (Aluminum) H137SUA...C & H138S18...C Series Hot Cabinets (Stainless)

ELECTRICAL SPECIFICATIONS:

Model No.	Volts	Watts	Amps	Hertz	Phase	NEMA	
H137SUA12C2K H137UA12C2K H138S1834C2K H1381834C2K	120	2000	16.7	60	1	5-20P	
H137SUA12C208 H137UA12C208 H138S1834C208 H1381834C208	208	2000	9.6	60	1	6-15P	
H137SUA12C240 H137UA12C240 H138S1834C240 H1381834C240	240	2000	8.3	60	1	6-15P	
H137SUA12CCAN H137UA12CCAN H137SUA9CCAN H137UA9CCAN H138S1834CCAN H1381834CCAN	120	1500	12.5	60	1	5-20P	} U.S. and Canada
H137SUA12CC15A H137UA12CC15A H137SUA9CC15A H137UA9CC15A H138S1834CC15A H1381834CC15A	120	1400	11.7	60	1	5-15P	} U.S. and Canada
H137SUA12C H137UA12C H137SUA9C H137UA9C H138S1834C H1381834C	120	1500	12.5	60	1	5-15P	} U.S. Only
H137SUA9C208 H137UA9C208	208	1500	7.2	60	1	6-15P	
H137SUA9C240 H137UA9C240	240	1500	6.2	60	1	6-15P	
H137SUA6C H137SUA5C H138S1816C H138S185C	120	1000	8.3	60	1	5-15P	
H137SUA6C208 H138S1816C208 H137SUA5C208 H138S185C208	208	1000	4.8	60	1	6-15P	
H137SUA6C240 H138S1816C240 H137SUA5C240 H138S185C240	240	1000	4.2	60	1	6-15P	

NOTE: The above model numbers are basic models. They may be followed by letters: **M**, **L**, **D** or ending with **S** and/or **Z**.

Insulated Hot Cabinet	FL-2251
Rev.10 (6/08)	Page 2 of 5

OPERATING and MAINTENANCE INSTRUCTIONS

Models: H137UA...C & H13818...C Series Hot Cabinets (Aluminum) H137SUA...C & H138S18...C Series Hot Cabinets (Stainless)

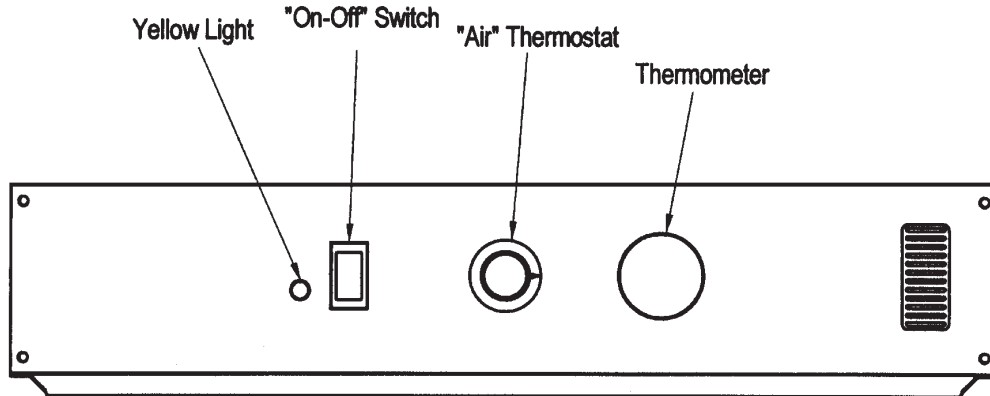

HOW TO INSTALL UNIT:

1. Place cabinet on level floor.
2. Place cabinet in a well ventilated area.
3. Plug cord end into proper wall outlet.

INITIAL OPERATION:

(For first-time operation only):

NOTE: A new oven needs to “burn off” manufacturing oils and excess adhesive before its first use.

Do NOT load food into oven until this has been done!

1. Turn the *POWER* switch on. The *yellow* light will turn on.
2. Turn thermostat to #10.
3. Let unit operate for one hour.
4. Turn unit off and let cool.
5. Wipe inside clean with detergent and hot water.

HOW TO START UNIT:

1. Turn the *POWER* switch on. The *yellow* light will turn on.
2. Turn the thermostat to #6½.
3. Preheat cabinet for one (1) hour.
4. Put food into cabinet.
5. Turn thermostat to desired setting and close door.
 - No. 8 setting = approx. 85°C / 185°F
 - No.6 setting = approx. 71°C / 160°F
 - No.4 setting = approx. 54°C / 130°F

Proper food holding temperature is 60°C / 140°F or higher.

NOTE: The optional digital thermometer display flashes when temperature in center of cabinet is below 140°F (60°C) or above 250°F (121°C). Call the factory if you need different settings.

TO TURN OFF UNIT:

Turn the *POWER* switch off. The *yellow* light will go out.

	WARNING	
RISK OF FIRE OR ELECTRIC SHOCK DO NOT OPEN		
WARNING: TO REDUCE THE RISK OF FIRE OR ELECTRIC SHOCK,		
DO NOT REMOVE COVER (OR BACK)		
NO USER-SERVICEABLE PARTS INSIDE		
REPAIR SHOULD BE DONE BY AUTHORIZED SERVICE PERSONNEL ONLY		

OPERATING and MAINTENANCE INSTRUCTIONS

Models: H137UA...C & H13818...C Series Hot Cabinets (Aluminum) H137SUA...C & H138S18...C Series Hot Cabinets (Stainless)

WARNING

BEFORE CLEANING CABINET:

1. Allow the cabinet to cool.
 2. Do NOT use abrasives or harsh chemicals.
- Is your cabinet aluminum or stainless steel construction? Be sure your cleaner is suitable for that material.**

Note: Stainless Steel cabinets have an “S” in their model numbers.

Cleaning hints:

1. Wipe up spills as soon as possible.
2. Clean cabinet regularly to avoid heavy dirt build-up.
3. Make a test spot with cleaner.
4. Follow manufacturer’s directions on cleaner.
5. Do not mix cleaners.
6. Avoid drips and splashes.

HOW TO CLEAN THE UNIT:

Soil	Cleaner	Method
Dirt	Mild Detergent* and hot water, or mild abrasive cleaner.	1. Wipe with soft, damp cloth. 2. Rinse with hot water. 3. Wipe Dry.
	Steam (no strong alkaline additive)	1. Rinse after steam cleaning. 2. Wipe Dry
Fingerprints, grease, oil	Mild abrasive cleaner. Oily or waxy cleaner.	Apply with soft, clean cloth.
	Chemical oven cleaner.	Follow oven cleaner manufacturer’s instructions
Water Spots	Mild abrasive cleaner.	1. Apply with soft, clean cloth. 2. Wipe with damp cloth.
<i>*Mild detergent includes soaps and non-abrasive cleaners.</i>		

Note: Gaskets are removable for cleaning.

TROUBLE-SHOOTING CHART:

FAILURE:

1. Yellow light at switch does NOT light.
2. Unit does not heat.
3. Unit gets too hot or won’t shut off.
4. Blower does not work or makes noise.

POSSIBLE CAUSE:

- 1a. Circuit breaker/fuse to wall outlet is blown
- 1b. Cord is unplugged from wall outlet.
- 1c. Switch is “OFF.”
- 2a. Thermostat set too low or is “OFF.”
- 2b. Switch is “OFF.”
- 3a. Defective electrical parts.
- UNPLUG UNIT FROM WALL OUTLET**
- 4a. Defective blower

Insulated Hot Cabinet	FL-2251
Rev.10 (6/08)	Page 4 of 5

OPERATING and MAINTENANCE INSTRUCTIONS

Models: H137UA...C & H13818...C Series Hot Cabinets (Aluminum) H137SUA...C & H138S18...C Series Hot Cabinets (Stainless)

REPLACEMENT PARTS: H137UA...C/H1381834C and H137SUA...C/H138S1834C

		120 V	208 V	240 V
Power Unit	2000W	0675-002	0675-005	0675-005
	2000W + dig thrm	0675-002-D	0675-005-D	0675-005-D
Canada only	1500W/20A	0675-002	0675-005	0675-005
<i>Canada only</i>	1500W/20A + dig	0675-002-D	0675-005-D	0675-005-D
<i>USA only</i>	1500W/15A	0675-002	0675-005	0675-005
<i>USA only</i>	1500W/15A + dig	0675-002-D	0675-005-D	0675-005-D
<i>USA &</i>	1400W/15A	0675-002	None	None
<i>Canada</i>	1400W/15A + dig	0675-002-D	None	None
	1000W/15A	0675-002	0675-005	0675-005
	1000W/15A + dig	0675-002-D	0675-005-D	0675-005-D
Blower kit		0769-180-K	0769-182-K	0769-182-K
Heater kit	2000W	0811-268	0811-269	0811-270
	1500W	0811-265	0811-266	0811-267
	1400W	0811-275	None	None
	1000W	0811-074	None	0811-074-01
Thermometer	Analog	5238-030	5238-030	5238-030
	Digital	5238-034	5238-034	5238-034
Transformer (used w/digital thermometer)		0769-159	0769-159	0769-159
Thermostat	Analog	0848-062-K	0848-062-K	0848-062-K
Power Cord	2000W	0810-065-12	0810-039-07	0810-039-07
	1500W (USA)	0810-029-06	0810-039-07	0810-039-07
	1500W (Canada)	0810-065-12	0810-039-07	0810-039-07
	1000W	0810-029-06	0810-039-07	0810-039-07
Power Switch		0808-116	0808-116	0808-116
Power Light		0766-094	0766-095	0766-095
Vent Fan		0769-165	0769-174	0769-174
<hr/>				
Door, complete	Aluminum	UA12/UA6/1834		1221-524
	Aluminum	UA9		1221-527
	Stainless Steel	UA12/UA6/1834		1221-525
	Stainless Steel	UA9		1221-526
	Stainless Steel	UA5/185		1221-545
Door, gasket	Aluminum	UA12/UA6/1834		0861-235
	Aluminum	UA9		0861-236
	Stainless Steel	UA12/UA6/1834		0861-185
	Stainless Steel	UA9		0861-182
	Stainless Steel	UA5/185		0861-250
Door, hinge	Aluminum			0519-087-K
	Stainless Steel			0519-074-K

Insulated Hot Cabinet	FL-2251
Rev. 10 (6/08)	Page 5 of 5

OPERATING and MAINTENANCE INSTRUCTIONS
Models: H137UA...C & H13818...C Series Hot Cabinets (Aluminum)
H137SUA...C & H138S18...C Series Hot Cabinets (Stainless)

WIRING DIAGRAM

