

**INSTALLATION, OPERATION and MAINTENANCE
MANUAL for Cres Cor
RADIANT OVENS**



**1000-CH-SS
1000-CH-AL**



**1000-CH-SS-SPLIT
1000-CH-AL-SPLIT**

Models: 1000-CH SERIES

Cabinet model number: _____

Cabinet serial number: _____

Authorized Service Agency: _____

Ph: _____ Fax: _____

Keep this manual for future reference.

Ovens	FL-2340
Rev. 9 (4/14)	Page 2 of 12

TABLE OF CONTENTS

SUBJECT	PAGE
INSTALLATION INSTRUCTIONS	3, 4
OPERATING INSTRUCTIONS	5
Illustration, Control Panel	5
MAINTENANCE INSTRUCTIONS	
How to Clean the Unit.....	6
Trouble Shooting Guide	7
Replacement Parts	8
Illustration; Ovens	9
Wiring Diagram for 1000-CH-SS or 1000-CH-AL.....	10,11
Wiring Diagram for 1000-CH-SPLIT	12
SERVICE POLICY and AGENCY LIST	FL-1400

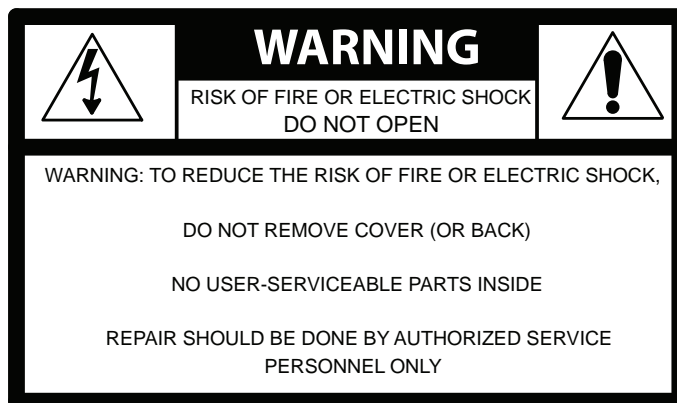

INSTALLATION INSTRUCTIONS

VENTING YOUR OVEN:

- The purpose of ventilating hoods is to direct and capture smoke, grease-laden vapors, heat, odors, or fumes.
- Low temperature equipment (maximum temperature 250°F/121°C) does not produce heat, odors, fumes, grease-laden vapors or smoke and is not required to be vented.
- Most jurisdictions consider our low-temperature ovens (maximum temperature is 350°F/177°C) as low-heat appliances not requiring vent hoods.
- Installation must conform with local codes. The authority having jurisdiction of enforcement of the codes will have the responsibility for making interpretations of the rules.

SPECIFICATIONS: All units are rated 3000 watts.

CMP MODEL NOS.	ELECTRICAL SPECS (AC SERVICE)			ELEC. LOAD		POWER SUPPLY REQUIREMENT				
	Volts	Ph	Hz.	Amps	Volts	Amps	Ph	Wire	Volts	NEMA
SINGLE OVENS										
1000CHSSSPLIT OR 1000CHALSPLIT	208 240	1 1	60 60	14 13	208 240	20 20	1 1	2 2	208 240	6-20P 6-20P
1000CHSSSPLIT3 OR 1000CHALSPLIT3	208 240	3 3	60 60	8 7	208 240	20 20	3 3	3 3	208 240	L15-20P L15-20P

SPECIFICATIONS: All units are rated 6000 watts. *For USA Only - Canadian is 6-50P

CMP MODEL NOS.	ELECTRICAL SPECS (AC SERVICE)			ELEC. LOAD		POWER SUPPLY REQUIREMENT				
	Volts	Ph	Hz.	Amps	Volts	Amps	Ph	Wire	Volts	NEMA
DOUBLE OVENS										
1000CHSS OR 1000CHAL	208 240	1 1	60 60	29 25	208 240	30 30	1 1	2 2	208 240	*6-30P *6-30P
1000CHSS3 OR 1000CHAL3	208 240	3 3	60 60	16 14	208 240	20 20	3 3	3 3	208 240	L15-20P L15-20P

Model number "AL" is aluminum outer body with stainless steel doors and interior.

All models designed for AC Service. Model number may have the letters: M, 2M, HT, Z, S or CAN.

IDENTIFYING YOUR CABINET:

Look for this label on the back of your cabinet. This information is needed when calling for questions or service.

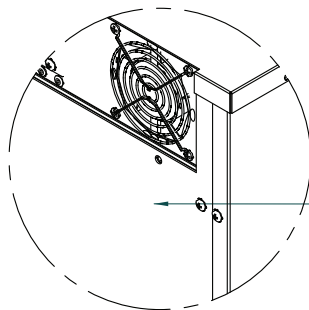

UPPER RIGHT CABINET CORNER



Ovens	FL-2340
Rev. 9 (4/14)	Page 4 of 12

INSTALLATION INSTRUCTIONS (continued)

HOW TO INSTALL CABINETS:

1. Remove all packing material from the inside and all vinyl from the outside of oven.
2. Place the oven in a well ventilated area on level floor.
Clearance requirements: 3" (76mm) at the back, 2" (51mm) at the top, 1" (25mm) at both sides.
3. Install the pan slide racks on the sidewalls, if necessary.
4. Slide drip pan(s) onto the bottom of the compartment(s).
5. Remove (3) screws at the bottom front of the oven, under the door (See Figure).
6. Screw the drip tray bracket to the oven in those holes and place the drip tray onto the bracket.

All models are rated at 208/240 Volts.

NOTE: OVENS NEED TO BE INSTALLED BY A QUALIFIED PERSON.

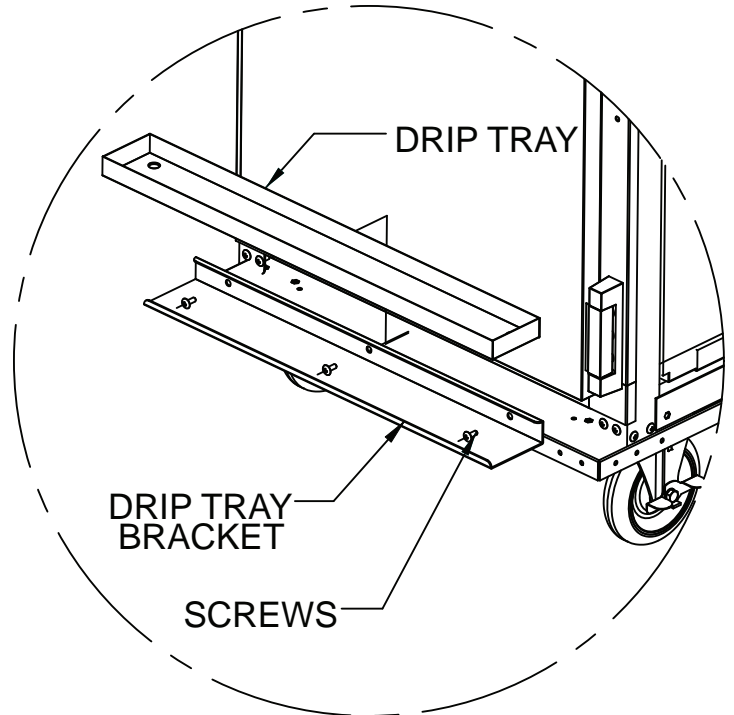

Check the voltage selector switch which is under an access cover on the back of the oven near the power cord.

- * Flip the switch "UP" for 208 Volts
- * Flip the switch "DOWN" for 240 Volts

MAKE SURE THE SWITCH POSITION MATCHES YOUR POWER SOURCE.

HOW TO REVERSE THE DOOR OPENINGS, IF NEEDED:

1. Unscrew and remove the latch from the door and magnetic strike from the cabinet.
2. Unscrew the hinges from the cabinet body and remove door.
3. Remove the screws plugging the mating hinge, latch and strike holes on the opposite sides of the cabinet body and door.
4. Re-mount the hinges to the opposite side of the cabinet and door.
5. Remount the latch and strike to the opposite side

Order Cres Cor Kit #6126 060 to convert 1 Phase ovens to 3 Phase

OPERATING INSTRUCTIONS

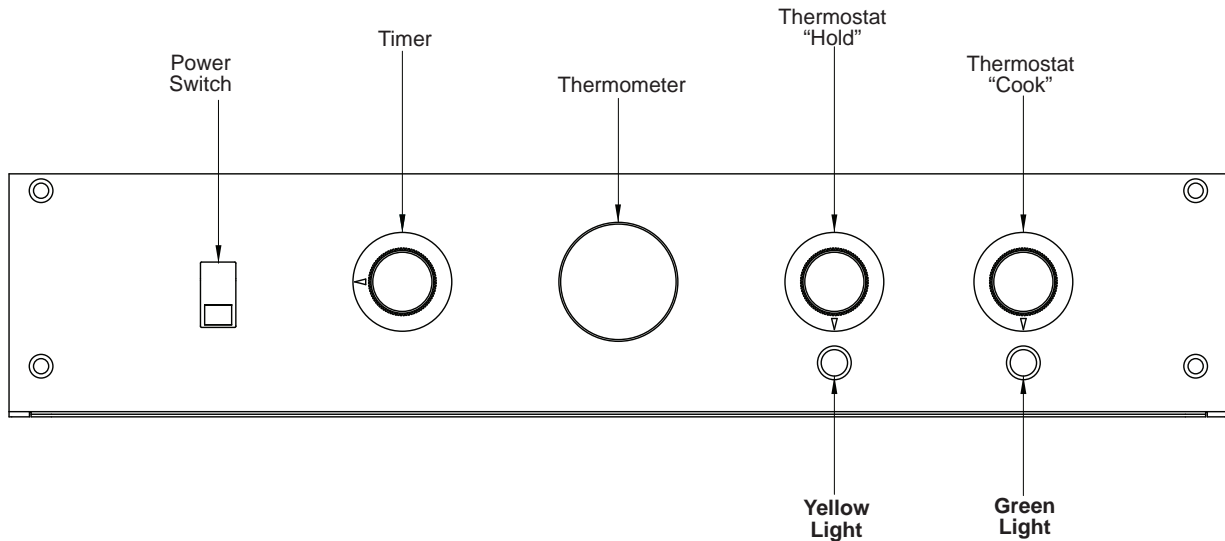

FOR FIRST-TIME OPERATION ONLY:

A new oven needs to “burn off” factory oils and glue before it’s first use. **Do NOT load food into oven until this has been done!**

1. Push switch to “ON”.
2. Set the **Cook** thermostat to 325°F/163°C.
3. Set the **Hold** thermostat to 150°F/66°C.
4. Set the timer to one (1) hour.
5. Allow oven to run automatically for one (1) hour of **Cook** cycle and 30 minutes of **Hold** cycle.
6. Turn oven off and let cool.
7. Wipe inside clean with detergent and hot water.

DOOR VENT ADJUSTMENT:

Open the door(s) and move the vent tabs on the inner door(s) as needed to release humidity.



WARNING

Air is VERY HOT when door is opened.

HOW TO START UNIT

(after first-time operation):

Push POWER switch “ON”.

NOTE: For **HOLD** or **COOK** mode, preheat unit to desired temperature for 30 minutes.

For Automatic Operation:

1. Set **Cook** thermostat to the cooking temperature you need.
2. Set **Hold** thermostat to the warming temperature you need. Proper food holding temperature is 140°F/60°C or higher.
3. Set **Timer** for the roasting time. The unit will automatically switch to the pre-set “hold” temperature after roasting time has expired.

For Holding Operation ONLY:

Cold food is **NOT** to be added when unit is operating in **HOLD** mode.

1. Set **HOLD** thermostat to the temperature you need.
2. Set Timer at zero.

TO SHUT DOWN UNIT:

Push SWITCH to “OFF”.

NOTE: Ventilating fans will continue to run until cabinet is cool. Do **NOT** disconnect the power supply to the cabinet while the ventilating fan is still operating.

Ovens	FL-2340
Rev. 9 (4/14)	Page 6 of 12

HOW TO CLEAN THE UNIT:

WARNING

BEFORE cleaning the cabinet:

1. **Unplug cord from wall. Allow cabinet to cool.**
2. **Do NOT hose cabinet with water.**
3. **Do NOT get water on controls.**
4. **Do NOT use abrasives or harsh chemicals.**

- Wipe up spills as soon as possible.
- Clean regularly to avoid heavy dirt build-up.

Cleaning Hints:

1. Use the mildest cleaning procedure that will do the job.
2. Always rub in the direction of polish lines to avoid scratching the surface.
3. Use only a soft cloth, sponge, fibrous brushes, plastic or stainless steel pads for cleaning and scouring.
4. Rinse thoroughly with fresh water after every cleaning operation.
5. Always wipe dry to avoid water marks.

MODELS: 1000-CH-SS & 1000-CH-SS-SPLIT

	SOIL	CLEANER	METHOD
STAINLESS STEEL CABINET Inside and Outside	Routine Cleaning	Soap or mild detergent* and water.	1. Sponge on with cloth 2. Rinse
	Stubborn Spots, Stains	Mild abrasive made for Stainless Steel.	1. Apply with damp sponge or cloth. 2. Rub lightly.
	Burnt on Foods or Grease	Chemical oven cleaner made for Stainless Steel.	Follow oven cleaner manufacturer's directions.
	Hard Water Spots & Scale	Vinegar	1. Swab or wipe with cloth. 2. Rinse and dry.

MODEL: 1000-CH-AL & 1000-CH-AL-SPLIT (Aluminum cabinet outside only with stainless steel doors and pan slides)

	SOIL	CLEANER	METHOD
ALUMINUM CABINET Outer body ONLY	Dirt	Mild detergent* and hot water, or mild abrasive cleaner.	1. Use soft, damp cloth. 2. Rinse with hot water. 3. Wipe dry.
		Steam (no strong alkaline additive).	1. Rinse after steam cleaning. 2. Wipe dry.
	Fingerprints, Grease, Oil	Detergent* and hot water.	1. Wipe with soft, damp cloth. 2. Rinse with hot water. 3. Wipe dry.
		Chemical oven cleaner made for aluminum.	Follow oven cleaner manufacturer's directions
		Mild abrasive cleaner. Oily or waxy cleaner.	Apply with soft, clean cloth.
Water Spots	Mild abrasive cleaner.	Wipe with damp cloth.	

**Mild detergents include soaps and non-abrasive cleaners.*

MAINTENANCE INSTRUCTIONS TROUBLE-SHOOTING GUIDE

WARNING

IF UNIT GETS TOO HOT OR WON'T SHUT OFF, DISCONNECT POWER AT BRANCH PANEL. DO NOT UNPLUG CORD!

If hot unit is *NOT* working, first check the following causes:

- | | |
|--|--|
| 1. Cord is unplugged from wall outlet. | 3. Switch(es) are turned off. |
| 2. Circuit breaker/fuse to wall outlet is blown. | 4. Thermostat(s) are turned off, or are set too low. |

PROBLEM	POSSIBLE CAUSE	SOLUTION
Oven does not heat, or doesn't heat properly	1. Thermostat(s) defective 2. Heater contactor 3. On/Off Switch *4. Fuses	1. Replace 2. Replace 3. Replace 4. Replace
Timer runs down, but oven does not go into hold mode.	Timer defective	Replace
Heaters will not shut off	1. Thermostat defective 2. Contactor defective	1. Replace 2. Replace
Vent fans do not shut off	1. Vent fan switch defective 2. Control compartment is still hot.	1. Replace 2. Wait until it cools Check "Heaters will not shut off"
Vent fans do not operate (See Note)	1. Vent fan switch defective 2. Vent fan defective *3. Fuses	1. Replace 2. Replace 3. Replace

**Fuses are in 6000 Watt units only*

NOTE: Vent fans will not operate until the control compartment requires ventilation to limit temperatures. Replacement of electrical components must be done by a qualified electrician. Refer to our *Service Agency list, FL-1400* (found in the back of this manual), of authorized service centers.

Ovens	FL-2340
Rev. 9 (4/14)	Page 8 of 12

REPLACEMENT PARTS

Include all information on nameplate when ordering parts

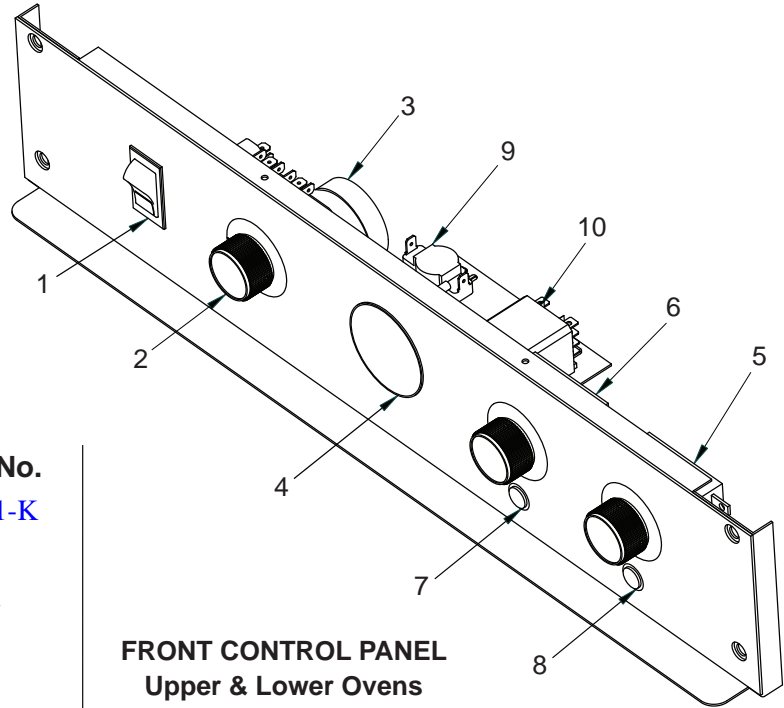

FRONT CONTROL PANEL
Upper & Lower Ovens

ITEM DESCRIPTION

1. Switch (On/Off)
2. Knob, Thermostat & Timer
3. Timer
4. Thermometer
5. Thermostat, Cook
6. Thermostat, Hold
7. Pilot Light, Yellow
8. Pilot Light, Green
9. Switch, Fan
10. Relay
11. Contactor
12. Terminal Block (Input)
13. Terminal Block
14. Toggle Switch
15. Vent Fan
16. Fan Guard
17. Heater Kit, 208V, 250 Watt
Heater Kit, 240V, 1000 Watt
18. Door Latch Kit
19. Latch Strike
20. Door Assembly
21. Door Gasket
22. Door Hinge

CMP Part No.

- 0808-113-01-K
0595-061
0849-009-K
5238-031
0848-082
0848-086
0766-096
0766-097
0848-034
0857-102
0857-131
0852-109
0852-091
0808-020
0769-174
0769-167
0811-291-K
0811-290-K
1006-122-01-K
1006-122-02-K
1221-573-K
0861-267
0519-074-K

ITEM DESCRIPTION

23. Casters
24. Casters w/brake
25. Pan Slides
26. Drip Pan
Drip Pan (after 2010)
27. Fuses, 3 Amp. (for units mfr'd before 7/08)
Fuse Holder (for units mfr'd before 7/08)
Fuses, 3 Amp. (for units mfr'd after 7/08)
Fuse Holder (for units mfr'd after 7/08)
28. Hi-Limit
29. Drip Tray
Wire Shelf
- Power Cord (3000 Watts, 1-PH)
- Power Cord (6000 Watts, 1-PH)
- Power Cord (6000 Watts, 3-PH)

CMP Part No.

- 0569-306-K
0569-306-BK
0692-200
1017-099
1017-100
0807-058
0807-048
0807 151
0807-150
0848-033
1017-100
1170-005
0810-173-01-K
0810-163-01-K
0810-164-01-K

REPLACEMENT PARTS

Include all information on nameplate when ordering parts

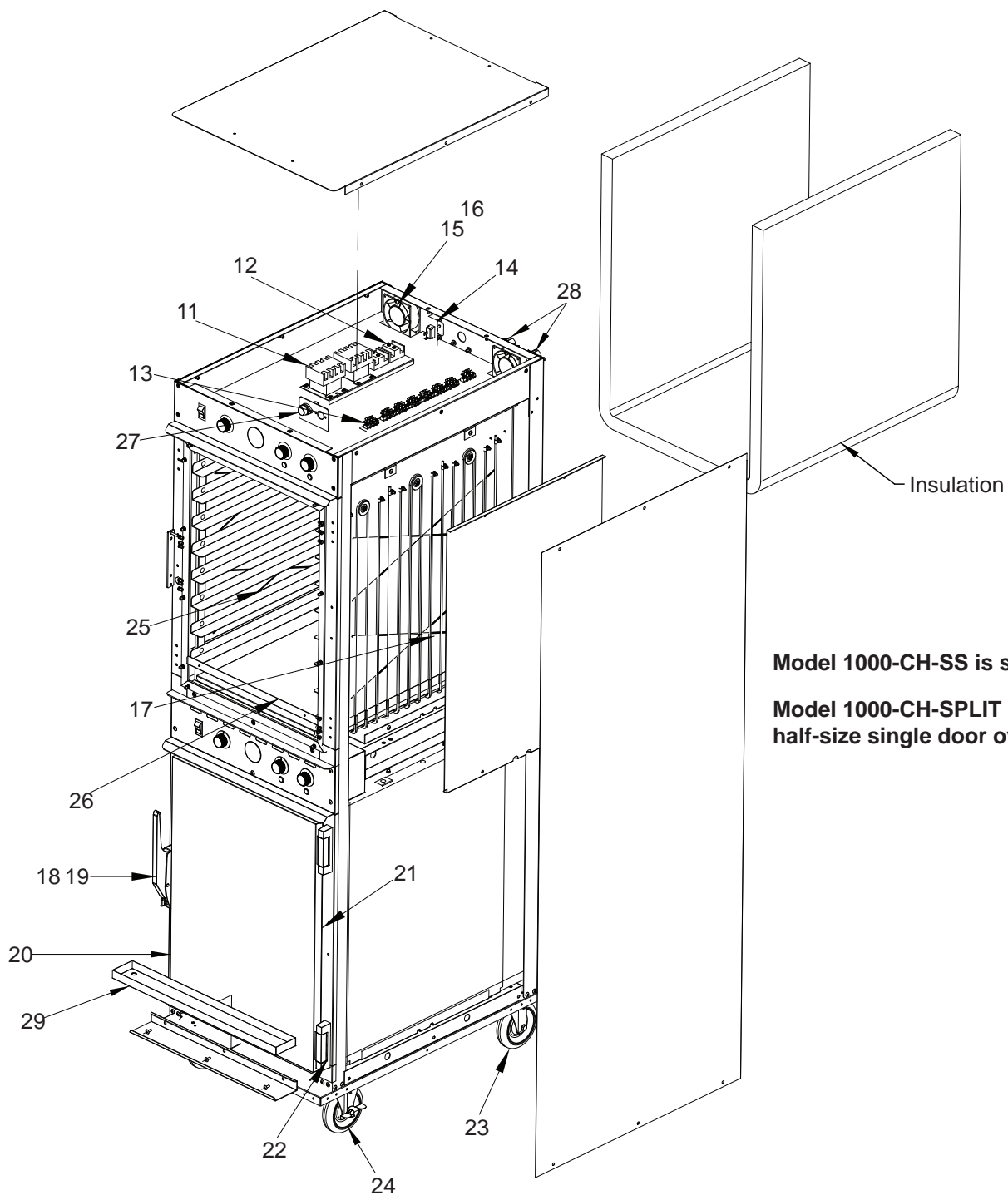

Model 1000-CH-SS is shown.

**Model 1000-CH-SPLIT is
half-size single door oven.**

Ovens	FL-2340
Rev. 9 (4/14)	Page 10 of 12



5925 Heisley Road • Mentor, OH 44060-1833

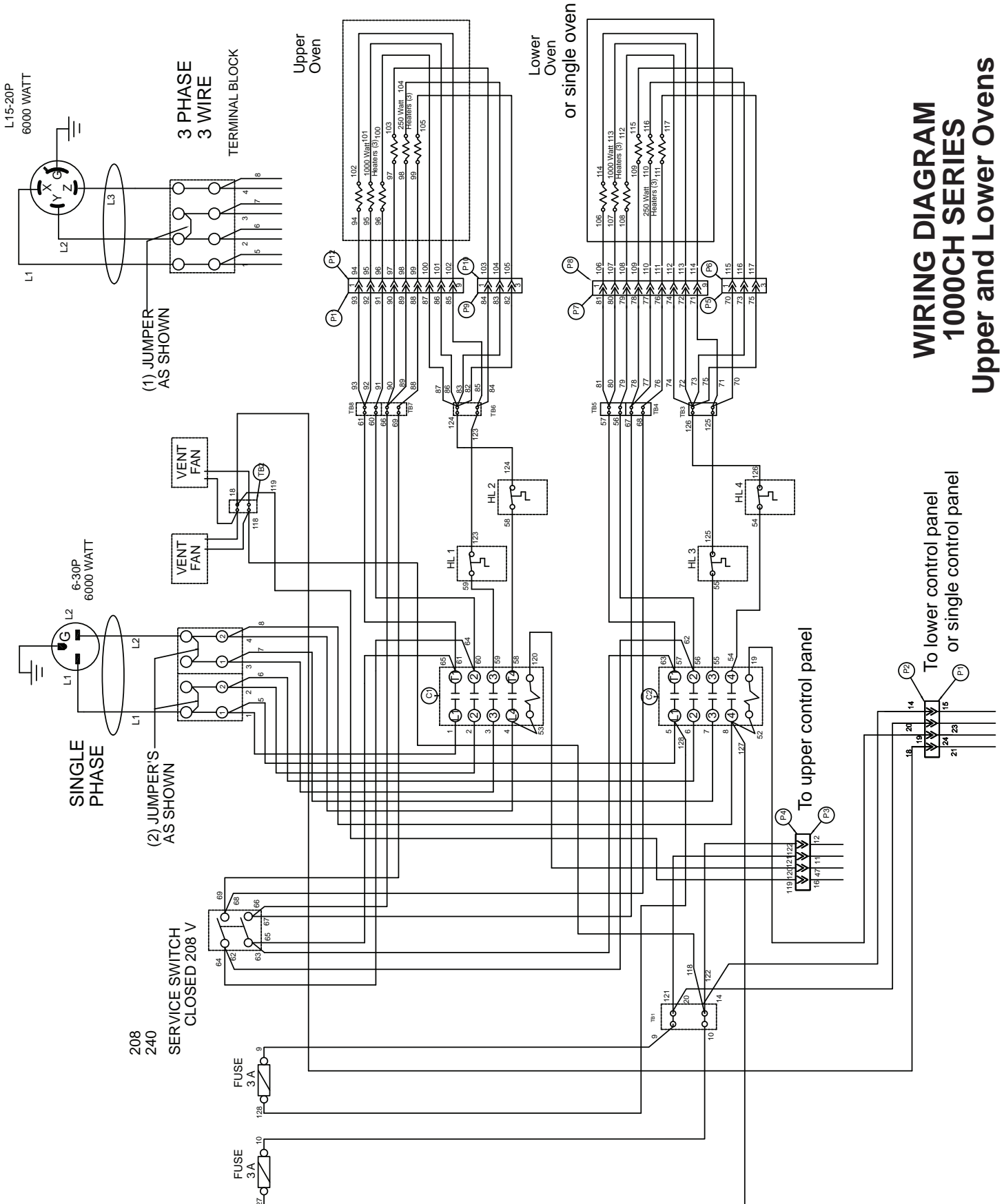

WIRING DIAGRAM FOR 1000CH SERIES, Control Panel

