

OPERATING and MAINTENANCE INSTRUCTIONS

Models: 1000HHSS2DE, 1000HHSS2DX, 1200HHSS2DE, & 1200HHSS2DX Hot Cabinets

ELECTRICAL SPECIFICATIONS:

Model No.	Volts	Watts	Amps	Hertz	Phase	NEMA
1000HHSS2DE 1000HHSS2DX 1200HHSS2DE 1200HHSS2DX	120	1800	15	60	1	5-20P
1000HHSS2DE240 1000HHSS2DX240 1200HHSS2DE240 1200HHSS2DX240	240	1800	7.5	60	1	6-15P

NOTE: The above model numbers are basic models. They may include letters: **P, M, E, L** or ending with **S, Z, U,** and/or **HT**.

IDENTIFYING YOUR CABINET:

Look for this label on the back of your cabinet. This information is needed when calling for questions or service.

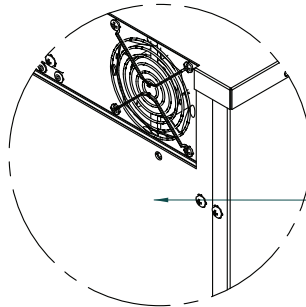

UPPER RIGHT CABINET CORNER



HOW TO INSTALL CABINETS:

1. Remove all packing material from the inside and all vinyl from the outside of the oven.
2. Place the oven in a well-ventilated area on level floor.
3. Install the pan slide racks, or posts and angles, on the sidewalls.

DOOR VENT ADJUSTMENT:

Open the door(s) and move the vent tabs on the inner door(s) as needed to release humidity.

HOW TO REVERSE THE DOOR OPENINGS, IF NEEDED:

1. Unscrew and remove the latch from the door and magnetic strike from the cabinet.
2. Unscrew the hinges from the cabinet body and remove the door.
3. Remove the screws plugging the mating hinge, latch and strike holes on the opposite sides of the cabinet body and door.
4. Re-mount the hinges to the opposite side of the cabinet and door.
5. Re-mount the latch and strike to the opposite side.

Insulated Hot Cabinet	FL-2390
Rev. 0 (2/16)	Page 2 of 6

OPERATING INSTRUCTIONS

for Models: 1000HHSS2DE and 1200HHSS2DE Hot Cabinets

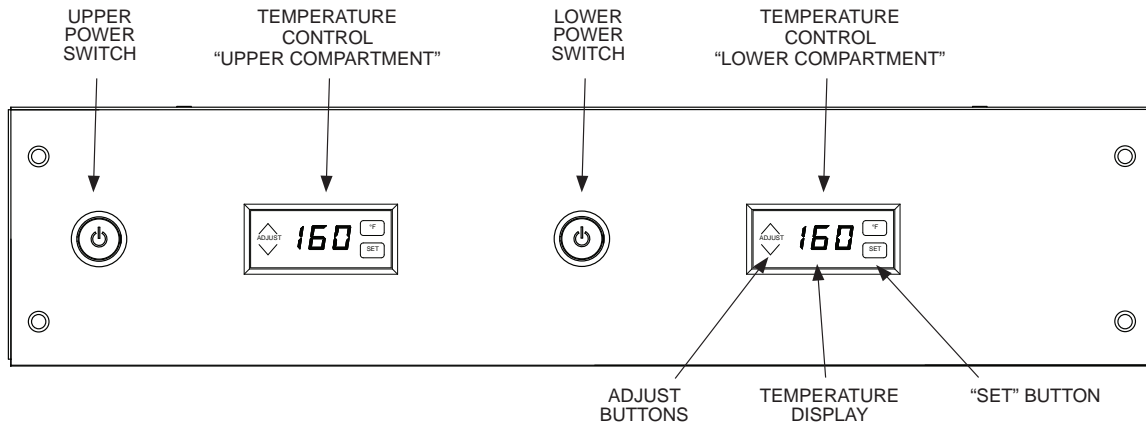

FIRST TIME START-UP:

1. Push the POWER switch, and run the unit for one hour.

NOTE: DO NOT PUT FOOD INTO CABINET!

This step is to burn off manufacturing oils and excess adhesive.

2. Let the cabinet cool and wipe inside clean with detergent and hot water before first use.

HOW TO HOLD FOOD:

1. Push POWER switch to “ON”. Yellow POWER LIGHT will come on.
2. Push the “SET” button on the TEMPERATURE CONTROL. The TEMPERATURE DISPLAY will show “SP1” (set point 1).
3. Press “SET” again and the current set point temperature will be displayed.
4. Press the ▲▼ ADJUST buttons to adjust to the desired temperature.
5. Press “SET” to save the temperature setting.
6. Preheat cabinet for 45 minutes.
7. Put product into cabinet.

NOTE: Proper food holding temperature is 140°F/60°C or higher.

	WARNING	
RISK OF FIRE OR ELECTRIC SHOCK DO NOT OPEN		
WARNING: TO REDUCE THE RISK OF FIRE OR ELECTRIC SHOCK,		
DO NOT REMOVE COVER (OR BACK)		
NO USER-SERVICEABLE PARTS INSIDE		
REPAIR SHOULD BE DONE BY AUTHORIZED SERVICE PERSONNEL ONLY		

WARNING

Air is VERY HOT when door is opened.

TO TURN OFF UNIT:

Push the POWER switch off; the light will go out.

OPERATING INSTRUCTIONS

for Models: 1000HHSS2DX and 1200HHSS2DX Hot Cabinets

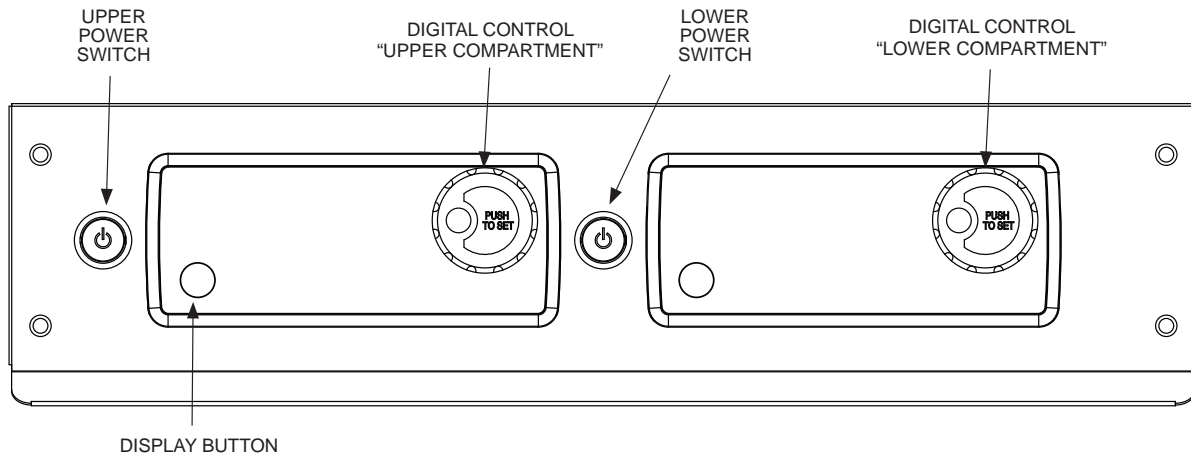

HOW TO CHANGE FROM °F TO °C (if needed)

1. Push the switch on; the light will come on.
2. Push and hold the “SET” button and the button in the lower left hand corner together for 5 seconds. You are now entered into the menu.
3. Scroll over the “Unit” and change it to “C”, then scroll to the “END”.

FIRST TIME START-UP:

NOTE: A new oven needs to “burn off” manufacturing oils and excess adhesive before its first use. *Do NOT load food into oven until this has been done!*

1. Push the POWER switch; the light will come on.

NOTE: The letters “LOTPR” (Low Temperature) will show on the control panel until it reaches 140°F (60°C).

2. Turn the control knob to show 200°F (93°C). Push the knob to set the temperature. Run the unit for one (1) hour.
3. Push the switch off and let cool.
4. Wipe the inside clean with detergent and hot water.

HOW TO HOLD FOOD:

1. Push the POWER switch; the light will come on.

NOTE: The letters “LOTPR” (Low Temperature) will show on the control panel until it reaches 140°F (60°C).

2. Turn the digital control knob(s) to a temperature for upper and/or lower compartments, between 140°F (60°C) and 220°F (104°C). Push the knob to set the temperature.
3. Preheat the cabinet for one (1) hour.
4. Put product into cabinet.

NOTE: Press the “Display” button to see the actual temperature inside the cabinet.

TO TURN OFF UNIT:

Push the POWER switch off; the light will go out.

⚠ WARNING

Air is VERY HOT when door is opened.

Insulated Hot Cabinet	FL-2390
Rev. 0 (2/16)	Page 4 of 6

MAINTENANCE INSTRUCTIONS

Models: 1000HHSS2D Hot Cabinets

WARNING

BEFORE CLEANING CABINET:

1. Allow the cabinet to cool.
2. Do NOT use abrasives or harsh chemicals.

Cleaning hints:

1. Wipe up spills as soon as possible.
2. Clean cabinet regularly to avoid heavy dirt build-up.
3. Make a test spot with cleaner.
4. Follow manufacturer's directions on cleaner.
5. Do not mix cleaners.
6. Avoid drips and splashes.
7. Do not use "Cres Clean" on plastic parts or labels.

HOW TO CLEAN THE UNIT:

Soil	Cleaner	Method
Dirt	Mild Detergent* and hot water, or mild abrasive cleaner.	1. Wipe with soft, damp cloth. 2. Rinse with hot water. 3. Wipe Dry.
	Steam (no strong alkaline additive)	1. Rinse after steam cleaning. 2. Wipe Dry
Fingerprints, grease, oil	Mild abrasive cleaner. Oily or waxy cleaner.	Apply with soft, clean cloth.
	Chemical oven cleaner.	Follow oven cleaner manufacturer's instructions
Water Spots	Mild abrasive cleaner.	1. Apply with soft, clean cloth. 2. Wipe with damp cloth.
<i>*Mild detergent includes soaps and non-abrasive cleaners.</i>		

Note: Gaskets are removable for cleaning.

TROUBLE-SHOOTING CHART:

FAILURE:

1. Switch light or control display does NOT light up.
2. Unit gets too hot or won't shut off.
3. Unit does not heat.
4. Thermostat control reads "err oo"

POSSIBLE CAUSE:

- 1a. Circuit breaker/fuse to wall outlet is blown
- 1b. Cord is unplugged from wall outlet.
- 1c. Switch is "OFF."
- 1d. Switch or control defective.
- 2a. Relay or control defective.

UNPLUG UNIT FROM WALL OUTLET

3. Defective heater, relay, or control.
4. Temperature probe defective.

OPERATING and MAINTENANCE INSTRUCTIONS

Models: 1000HHSS2DE, 1000HHSS2DX, 1200HHSS2DE, & 1200HHSS2DX Hot Cabinets

CABINET REPLACEMENT PARTS:

Model Nos.	1000HHSS2DE	1200HHSS2DE
	1000HHSS2DX	1200HHSS2DX
Angle Kit (2 per kit)	--	0621-281-K
Casters, Rigid	0569-306-R	0569-306-R
Casters w/ brake	0569-306-B	0569-306-B
Door Assembly	1221-573-K	1221-652-K
Door Gasket	0861-267	0861-292
Door Latch Kit	1006-122-01-K	1006-122-01-K
Hinge Kit (2)	0519-109-K	0519-109-K
Latch Strike Kit	1006-122-02-K	1006-122-02-K
Pan Slide Insert (1)	1170-122-01	--
Post, Angle (1)	--	0696-274

ELECTRICAL REPLACEMENT PARTS:

Model Nos.	1000HHSS2DE	1000HHSS2DX
	1200HHSS2DE	1200HHSS2DX
Digital Thermostat	0848-075	0848-092-01
Fan Guard	0769-167	0769-167
Heater, 120V	0811-066-K	0811-066-K
Heater, 240V	0811-066-1K	0811-066-1K
Power Cord, 120V	0810-065-10	0810-065-10
Power Cord, 240V	0810-039-02	0810-039-02
Relay	0857-134	0857-134
Sensor, Thermostat	0848-075-01	0848-091
Strain Relief, 120V	0818-050	0818-050
Strain Relief, 240V	0818-057	0818-057
Switch, On/Off	0808-125	0808-125
Terminal Block, 2-pole	0852-109	0852-109
Terminal Block, 3-pole	0852-096	0852-096
Terminal Block, 4-pole	0852-119	0852-119
Transformer	0769-159-01	0769-159-01
Vent Fan, 120V	0769-165	0769-165
Vent Fan, 240V	0769-174	0759-174

Insulated Hot Cabinet	FL-2390
Rev. 0 (2/16)	Page 6 of 6

WIRING DIAGRAM FOR 120 VOLT AND 240 VOLT

