

INSTALLATION, OPERATION and MAINTENANCE MANUAL for Cres Cor 8kW RETHERMALIZERS

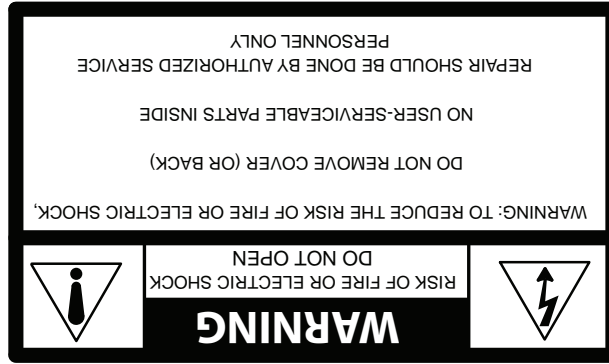

REVOLUTION FOODS
MODEL RO151037
AND
MODEL RO151038 (250° Max. Rethermalizer)



SUBJECT	PAGE
INSTALLATION INSTRUCTIONS	3
OPERATING INSTRUCTIONS	
First Time Operation	4
Using Pre-Set Recipes	4
How to Use Control for Retherm & Holding	5
Cooking With Food Probes	6
MAINTENANCE INSTRUCTIONS	
How to Clean the Unit	7
Trouble Shooting Guide	8, 9
Cabinet Replacement Parts	10
Hot Unit Replacement Parts	11
Wiring Diagram For 208 Volt, 1 Phase	12
SERVICE POLICY and AGENCY LIST	FL-1400

TABLE OF CONTENTS

FL-R0151037	Page 2 of 12
Rethermizer	Rev. 1 (1/16)

INSTALLATION INSTRUCTIONS

VENTING YOUR CABINET:

1. The purpose of ventilating hoods is to direct and capture smoke, grease-laden vapors, heat, odors, or fumes.
2. Low temperature equipment (maximum temperature 250°F/121°C) does not produce heat, odors, fumes, grease-laden vapors or smoke and is not required to be vented.
3. Most jurisdictions consider our low-temperature units (maximum temperature is 350°F/177°C) as low-heat appliances not requiring vent hoods.
4. Installation must conform with local codes. The authority having jurisdiction of enforcement of the codes will have the responsibility for making interpretations of the rules.

HOW TO INSTALL CABINETS:

1. Remove all packing material from inside and outside of cabinet.
2. Position cabinet on level floor; install the cabinet interior (pan slides) if not already installed.
3. Plug power cord into proper wall receptacle.

UNIT SPECIFICATIONS: Unit uses six (6) elements (1325 watts each). Units are rated 8000 watts.

MODEL NOS.	ELECTRICAL SPECS (AC SERVICE)			ELEC. LOAD		POWER SUPPLY REQUIREMENT ALL 3 PHASE IS 3 WIRE + GROUND			
	VOLTS	PHASES	HZ	AMPS	VOLTS	AMPS	PHASES	VOLTS	RECEPTACLE
RO151037 RO151038	208	1	60	39	208	50	1	208	6-50R



**CABINET MODEL RO151038 IS
PRESET TO A MAXIMUM OF 250°F. TEMPERATURE**

Rethermalizer	FL-RO151037
Rev. 1 (1/16)	Page 4 of 12

OPERATING INSTRUCTIONS



FIRST-TIME OPERATION

NOTE: A new cabinet needs to “burn off” manufacturing oils and excessive adhesive before its first use.

Do NOT load food until this has been done!

1. Push the **POWER** button on; the light will come on.

NOTE: The letters “LOTPr” (low temperature) will show on the control display until it reaches 140°F (60°C).

2. Press the **COOK** button.
3. Turn the **SET** control knob to show 350°F. Push the **SET** knob to set the temperature.

4. Push the **HOLD** button. Turn the **SET** knob to 150°F (65°C). Push the **SET** knob to set the temperature.
5. **TIME** button will light. Turn **SET** knob to one (1) hour. Push the **SET** knob to set the time.
6. Push **START** button. Control will display “PREHT”, then in approximately 15 minutes “READY”.
7. Push **START** button again to begin the cooking/burn off process.
8. Turn the unit off and let cool. (Open door)
9. Wipe the inside clean with detergent and hot water.

COOKING WITH PRE-SET RECIPES:

The control can hold up to 18 saved recipes, 5 of them have been preset for different types of food product.

Recipe #	Food Type	Cook Temp (°F)	Hold Temp (°F)	Cook Time (min)
Recipe 1	Very delicate foods	225	135	20
Recipe 2	Delicate foods	250	135	25
*Recipe 3	Dense foods	270	135	35
Recipe 4	Vegetable #1	250	135	75
Recipe 5	Vegetable #2	250	135	110

* For RO151034 only: Recipe #3, Cook Temp. is 250°F at 45 min. of Cook Time

OPERATING INSTRUCTIONS *(continued)*



COOKING WITH PRE-SET RECIPES:

1. Push Orange Power On button. Left side of control panel. Display will read **“LOtPr”** and the Retherm unit will be in HOLD mode.
2. Push the **“RECIPE”** button to select Preset Recipe process. Button will flash.
3. Turn the **SET** knob to select a recipe as: **“rcP01”** or **“rcP02”** or **“rcP03”** or **“rcP04”** or **“rcP05”**. Push the **SET** knob to select and start the preset process. Unit will display **“PrEHt”**.
4. Control will next flash **“PUSH StArt”** and alarm sounds. Load foods into the oven and close doors.
5. Push the **“START”** button to start the Retherm/Cook process. Display will change between the set COOK temperature and the countdown of the timer as pre-programmed.
6. When timer reaches display of **“00:00”**, it will change between the set HOLD temperature and a count-up running time. Alarm will sound. Retherm unit will display how long foods have been on hold.
5. Turn the set knob to the required temperature. Push the set knob to accept the temperature setting.
6. Display will automatically move to the **“TIME”** button (if no food probe is plugged into the probe jack).
7. Turn the set knob to the required time. Push the set knob to accept the time setting.
8. Control will go to **“PrEHt”** and start heating to the set COOK temperature.
9. Control will next flash **“PUSH StArt”** and alarm sounds. Load foods into the oven and close door.
10. Push the **“START”** button to begin the Retherm/Cook process. Display will change between the set COOK temperature and the countdown of the timer.
11. When timer reaches display of **“00:00”**, it will change between the set HOLD temperature and a count-up running time. Alarm will sound. Unit will display how long foods have been on hold.

COOKING WITH TIME AND TEMPERATURE:

1. Push Orange Power On button. Left side of control panel. Display will read **“LOtPr”** and the Retherm unit will be in the HOLD mode.
2. Push **“COOK”** button on display panel to program a Retherm temperature. Button will flash.
3. Turn the set knob to the required temperature. Push the set knob to accept the temperature setting.
4. Display will move to the **“HOLD”** button. Button will flash until programmed.

Rethermalizer	FL-RO151037
Rev. 1 (1/16)	Page 6 of 12

OPERATING INSTRUCTIONS *(continued)*



COOKING WITH FOOD PROBES:

1. Push Orange Power On button. Left side of control panel. Display will read “LOtPr” and Retherm unit will be in HOLD mode.
2. Insert Food Probe into the probe jack on right side of control panel. **Must be done prior to programming the control.**
3. Push “COOK” button on display panel to program Retherm temperature.
4. Turn the set knob to the required COOK/REThERM temperature. Push the set knob to accept the temperature setting.
5. Display will automatically move to the “HOLD” button.
6. Turn the set knob to the required HOLD temperature. Push the set knob to accept the temperature setting.
7. Display will automatically move to the “PROBE” button.
8. Turn set knob to the required internal food temperature planned for stopping the COOK/REThERM process. Push the set knob to accept the setting.
9. Control will automatically go to “PrEHt” and start heating to the set COOK temperature.
10. Control will next flash “PUSH StArt” and alarm sounds. Load foods into the oven cavity, insert the food probe into an item in the middle of a pan, in the center of the oven and close the door.

11. Push the “START” button to begin the Retherm/Cook process. Display will show the actual internal food temperature.
12. When food probe reaches the set internal temperature, the unit will automatically shift to HOLD and display the set HOLD air temperature. The alarm will sound.

Notes: To check internal temperature during cooking or holding, push the “DISPLAY” button.

To stop the cooking process and reset oven controls, push the “CANCEL” button.

EMERGENCY NUMBER:
Call Tim Davis @ 443/ 848-7315

MAINTENANCE INSTRUCTIONS HOW TO CLEAN THE UNIT

WARNING

BEFORE cleaning the cabinet:

1. **Unplug cord from wall. Allow cabinet to cool.**
2. **Do NOT hose cabinet with water.**
3. **Do NOT get water on controls.**
4. **Do NOT use abrasives or harsh chemicals.**
5. **Do NOT use “Cres Clean” (or any citrus cleaner) on labels or plastic parts.**

Cleaning Hints:

1. Use the mildest cleaning procedure that will do the job.
2. Always rub in the direction of the polish lines to avoid scratching the surface.
3. Use only a soft cloth, sponge, fibrous brushes, plastic or stainless steel pad for cleaning and scouring.
4. Rinse thoroughly with fresh water after every cleaning operation.
5. Always wipe dry to avoid water marks.

CARE & USE OF FOOD PROBES: DO'S & DON'TS

DO	DON'T
1. Sanitize (clean) the stainless steel probe after every use.	1. NEVER remove probe from a food product and place directly into new food items. Probe must be cleaned and sanitized before reuse.
2. Wipe clean with soapy, damp cloth. Rinse with clear water cloth.	2. DO NOT submerge the plastic handle, wires or connector/plug into water. Clean as instructed with soapy cloth and rinse with clean wet cloth.
3. Sterilize with food grade alcohol wipe prior to reuse in another food item.	3. NEVER pull on the wires to remove probe from food products or the receptacle. Always use the plastic handle or jack to insert and remove the probe from the foods and cabinet itself.
4. Pull/Remove the probe out of the food using the plastic handle only.	4. Take care NOT to catch or bend the probe in the door closure. The probe is a sensitive measuring device and should be replaced if damaged.
5. Designate a proper storage place for probes like the manager's office.	

Rethermalizer	FL-RO151037
Rev. 1 (1/16)	Page 8 of 12



MAINTENANCE INSTRUCTIONS TROUBLE-SHOOTING GUIDE, continued

HOW TO CLEAN THE UNIT:

	SOIL	CLEANER	METHOD
CABINET Inside and Outside (Stainless Steel)	ROUTINE CLEANING	Soap, ammonia or mild detergent* and water.	1. Sponge on with cloth 2. Rinse
	STUBBORN SPOTS, STAINS	Mild abrasive made for Stainless Steel.	1. Apply with damp sponge or cloth. 2. Rub lightly.
	BURNT ON FOODS OR GREASE	Chemical oven cleaner made for Stainless Steel.	Follow oven cleaner manufacturer's directions.
	HARD WATER SPOTS & SCALE	Vinegar	1. Swab or wipe with cloth. 2. Rinse and dry.
<i>* Mild detergents include soaps and non-abrasive cleaners</i>			

HOW TO ADJUST THE DOOR LATCH:

1. For vertical (up and down movement) adjustment:
 - a. Loosen (2) screws located in magnetic strike.
 - b. Move strike up or down for alignment to magnet on latch.
 - c. Tighten screws to secure
2. For horizontal (greater or lesser magnetic draw) adjustment:
 - a. Loosen (4) screws in door latch.
 - b. Move latch forward or backward to adjust magnetism.
 - c. Tighten screws to secure.

TROUBLE-SHOOTING GUIDE



IF OVEN GETS TOO HOT OR WON'T SHUT OFF, DISCONNECT POWER AT BRANCH PANEL. DO NOT UNPLUG CORD!

If unit is *NOT* working, first check the following causes:

1. Cord is unplugged from wall outlet.
2. Circuit breaker/fuse to wall outlet is blown.
3. Switch is turned off.
4. Fuse on back of unit is blown.

PROBLEM	POSSIBLE CAUSE	SOLUTION
Rethermalizer does not turn on	1. Power switch is bad 2. Retherm control is bad.	1. Replace 2. Replace

MAINTENANCE INSTRUCTIONS TROUBLE-SHOOTING GUIDE *(continued)*

IF THE OVEN TURNS ON:

PROBLEM	POSSIBLE CAUSE	SOLUTION
Rethermalizer does not heat, or doesn't heat properly	<ol style="list-style-type: none"> Sensor Heater contactor Loose wiring at heater contactor Retherm control High Limit 	<ol style="list-style-type: none"> Replace Replace Replace Replace Replace
Blowers do not operate	<ol style="list-style-type: none"> Air retherm switch Blower Retherm control 	<ol style="list-style-type: none"> Replace Replace Replace
Heater will not shut off	<ol style="list-style-type: none"> Control defective Heater contactor 	<ol style="list-style-type: none"> Replace Replace
Vent fans do not shut off	<ol style="list-style-type: none"> Vent fan switch defective Control compartment is still hot. 	<ol style="list-style-type: none"> Replace Wait until it cools Check "Heater will not shut off"
Vent fans do not operate (See Note)	<ol style="list-style-type: none"> Vent fan switch defective Vent fan defective 	<ol style="list-style-type: none"> Replace Replace
Control will not switch from "COOK" to "HOLD" (timed mode)	<ol style="list-style-type: none"> Unit is in "PROBE" mode. Retherm control defective 	<ol style="list-style-type: none"> Cancel recipe and switch to "TIMED" mode Replace
Control will not switch from "COOK" to "HOLD" (probe mode)	<ol style="list-style-type: none"> Unit is in "TIMED" mode Probe not plugged in Probe defective Retherm control defective 	<ol style="list-style-type: none"> Cancel recipe and switch to "PROBE" mode Plug in probe Replace Replace
Control will not switch to "COOK" (probe mode)	<ol style="list-style-type: none"> Unit is in "TIMED" mode Probe temperature setting lower than probe temperature Probe not plugged in Retherm control defective 	<ol style="list-style-type: none"> Switch to "PROBE" mode Set probe temperature to desired temperature Plug in probe Replace

ERROR CODES:

CODE DISPLAYED	CAUSE	SOLUTION
no p	No food probe	Plug in probe
Err0	Temp probe bad	Replace

NOTE: Vent fans will not operate until the control compartment requires ventilation to limit temperatures. Replacement of electrical components must be done by a qualified electrician.

Refer to our *Service Agency list, FL-1400* (found in the back of this manual), of authorized service centers. Instructions for replacing parts are included in replacement parts list.

Rethermalizer	FL-RO151037
Rev. 1 (1/16)	Page 10 of 12

REPLACEMENT PARTS
Include all information on nameplate when ordering parts

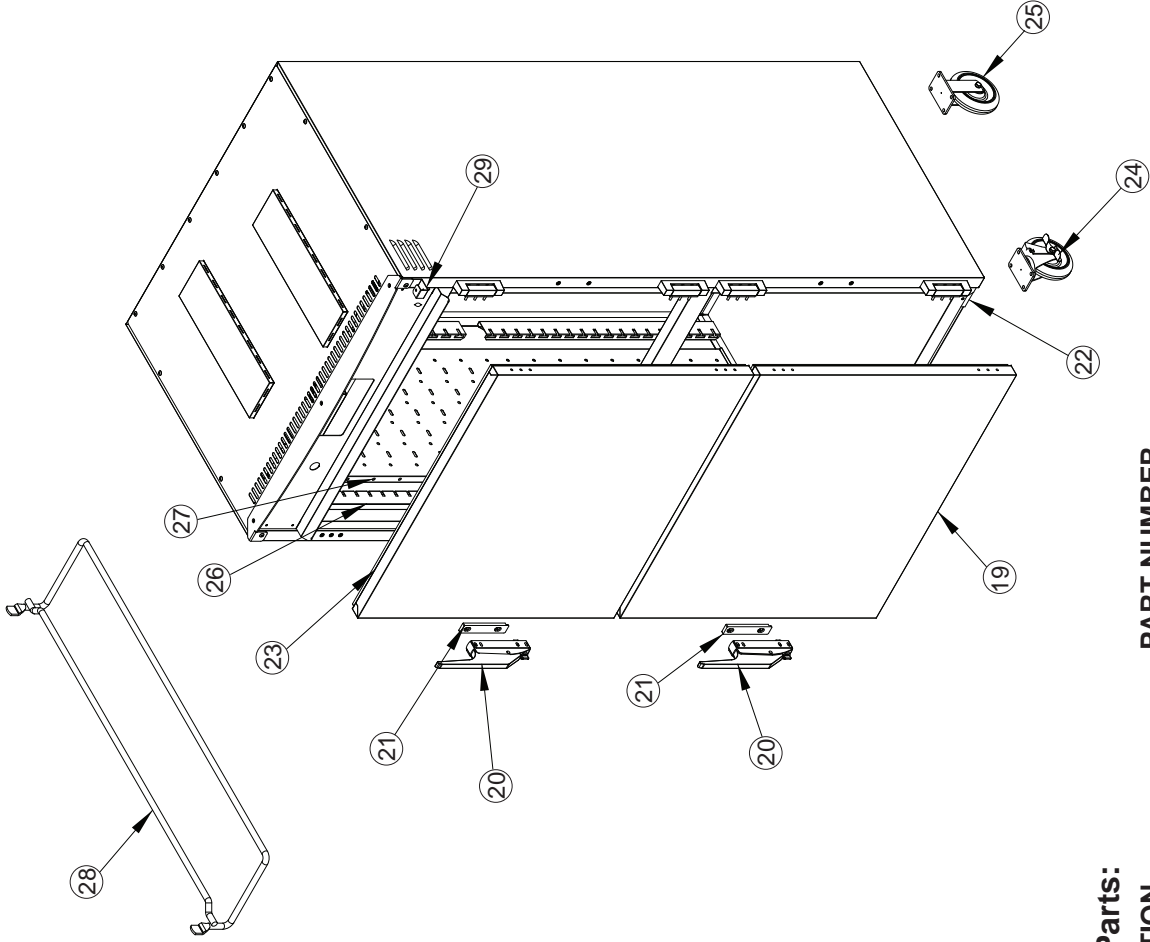

Replacement Parts:

ITEM DESCRIPTION	PART NUMBER
19. Door Assembly	1221-579-K
20. Door Latch Kit	1006-122-01-K
21. Door Strike Kit	1006-122-02-K
22. Door Hinge Kit	0519-109-K
23. Door Gasket	0861-235-K
24. Casters	0569-306
25. Casters w/brake	0569-306-B
26. Posts	0696-250
27. Air Tunnel	0546-146-C
28. Wire Angles (2 per kit)	0621-281
29. Probe Holder	5456-045
Food Probe 3" Long	0848-109

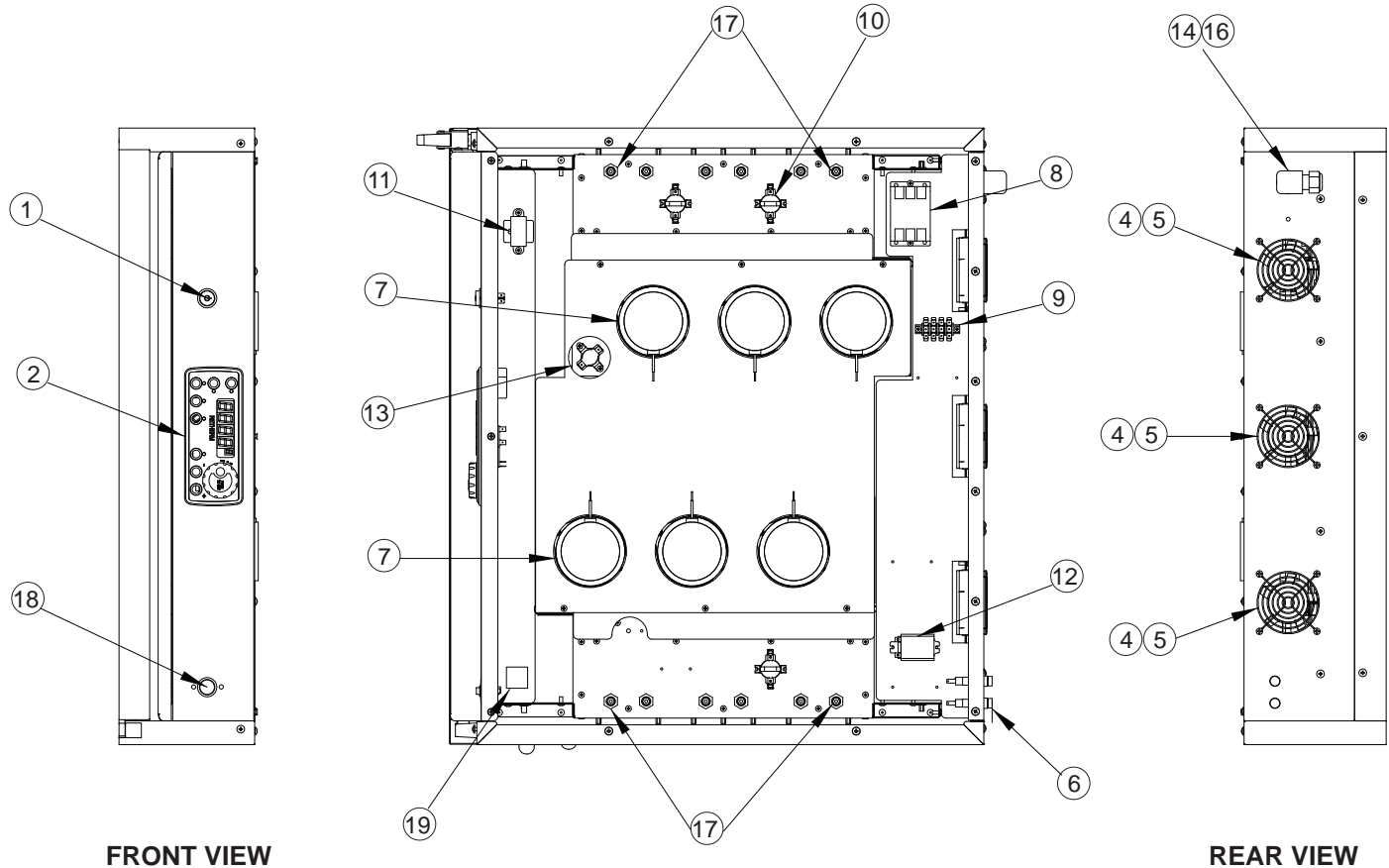

Electrical Replacement Parts:

ITEM DESCRIPTION

1. Switch (On/Off)
2. Retherm 350° Thermostat Digital Control (RO151037)
Thermostat 250° Digital Control (RO151038)
Sensor
4. Vent Fan
5. Fan Guard
6. Fuse
Fuse Holder
7. Blower Kit
8. Contactor
9. Terminal Block, rear

Part No.

- 0808-125
0848-092-09-K
0848-092-10-K
0848-091
0769-174
0769-167
0807-155
0807-150
0769-186-K
0857-026
0852-093

ITEM DESCRIPTION

10. Hi Limit Switch
11. Transformer
12. Relay
13. Fan Switch
14. Power Cord Kit
16. Strain Relief Kit
17. Heater Kit (208V)
18. Connector, Probe
Food Probe 3" Long
19. Alarm Assy

Part No.

- 0848-077
0769-197
0857-102
0848-034
0810-178-K
0818-103-K
0811-306
0848-106-02
0848-109
0908-009-01

