



Installation Instructions

Part Number 920076

IMPORTANT: Read entire instructions before starting the installation.

SAFETY CONSIDERATIONS

Read and follow manufacturer instructions carefully. Follow all local electrical codes during installation. All wiring must conform to local and national electrical codes. Improper wiring or installation may damage sensor.

Recognize safety information. This is the safety alert symbol . When the safety alert symbol is present on equipment or in the instruction manual, be alert to the potential for personal injury.

Understand the signal words **DANGER**, **WARNING**, and **CAUTION**. These words are used with the safety alert symbol. **DANGER** identifies the most serious hazards which will result in severe personal injury or death. **WARNING** signifies a hazard which could result in personal injury or death. **CAUTION** is used to identify unsafe practices which would result in minor personal injury or property damage.

GENERAL

The Remote Duct Sensor (RDS) measures duct temperature when configured in a 33CS VVT® (Variable Volume and Temperature) or TEMP system. The sensor measures temperature with a range of 30 to 180 F.

An RDS can be used in 2 different applications: as a DX (Direct Expansion) coil temperature sensor or as a supply air temperature sensor.

INSTALLATION

Step 1 — Sensor Location — The sensor can be located up to 1000 ft from the single zone relay pack or zone damper actuator.

DX COIL TEMPERATURE SENSOR APPLICATIONS — The RDS should be located downstream of the HVAC (Heating, Ventilation, and Air Conditioning) equipment DX coil, but upstream of any electric heating device. See Fig. 1.

SUPPLY AIR TEMPERATURE SENSOR APPLICATIONS — Locate the RDS in the system supply air duct. See Fig. 1.

Step 2 — Wiring Requirements — The RDS wiring has the following requirements:

1. All system wiring must be in compliance with all applicable local and national codes.
2. All control, communication bus, and sensor wiring should be color coded in conformance with Carrier recommendations.
3. All wiring should be 2-conductor, 18- to 22-gage, shielded wire. The maximum distance between the RDS to the zone damper or relay pack for 18-gage wire is 1000 ft. The

maximum distance between the RDS to the zone damper or relay pack for 22-gage wire is 500 ft.

4. Connect one end of the wire shield to the chassis ground. Do not connect shield at sensor side. Cut and tape shield at other end of sensor wire.

⚠ CAUTION

Do not ground the shielded wire in more than one location. If the shield is grounded in two or more locations, an electrical charge may form around the wire and disrupt communication.

NOTE: Each unused connector plug wire should be individually capped with a wire nut. Do not leave bare exposed wires.

NOTE: When used with a Bypass Controller, the RDS can function as a Miscellaneous Temperature sensor to monitor air temperature at an additional location in the system. For this application, the RDS is wired to the actuator of the bypass controller master damper.

Step 3 — Install Sensor

1. Cut or drill a 1¼-in. hole in the duct at the location the RDS will be installed.
2. Remove the RDS cover plate and insert the sensor probe through the 1¼-in. hole. See Fig. 2.
3. Drill two ⅛-in. holes (to accept two no. 6 sheet metal screws) through the pre-drilled holes in the RDS back plate.
4. Use the two sheet metal screws included with the RDS to mount the RDS to the duct.
5. Insert the field wiring through one of the pre-drilled holes in the sides of the RDS back plate. Connect the sensor to the field wiring using wire nuts. All wire nut connections should be enclosed within the RDS case.
6. Re-attach the RDS cover.

Step 4 — Wire Sensor

WIRING TO DAMPER ACTUATOR — Use the multi-sensor wiring harness included with the RDS to interface the sensor to the damper circuit board. See Fig. 3 and 4. The RED and BLACK wires of the RDS connect to the RED and BLACK wires of the “R” bundle of the harness cable.

WIRING TO SINGLE ZONE RELAY PACK — To wire the RDS as a supply air sensor, connect the BLACK wire to terminal 13 and the RED wire to terminal 15 of the single zone relay pack. See Fig. 5.

To wire the RDS as a DX coil sensor, connect the BLACK wire to terminal 13 and the RED wire to terminal 14 of the single zone relay pack. See Fig. 6.

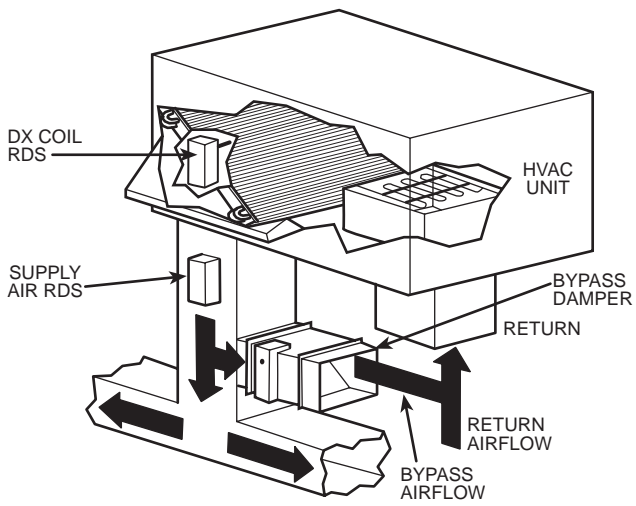

DX — Direct Expansion

Fig. 1 — Remote Duct Sensor (RDS) Location

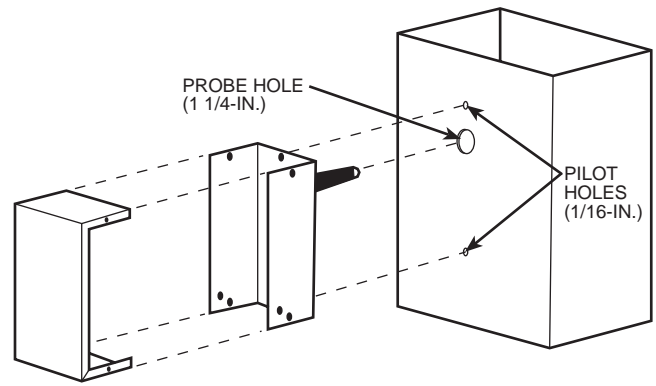
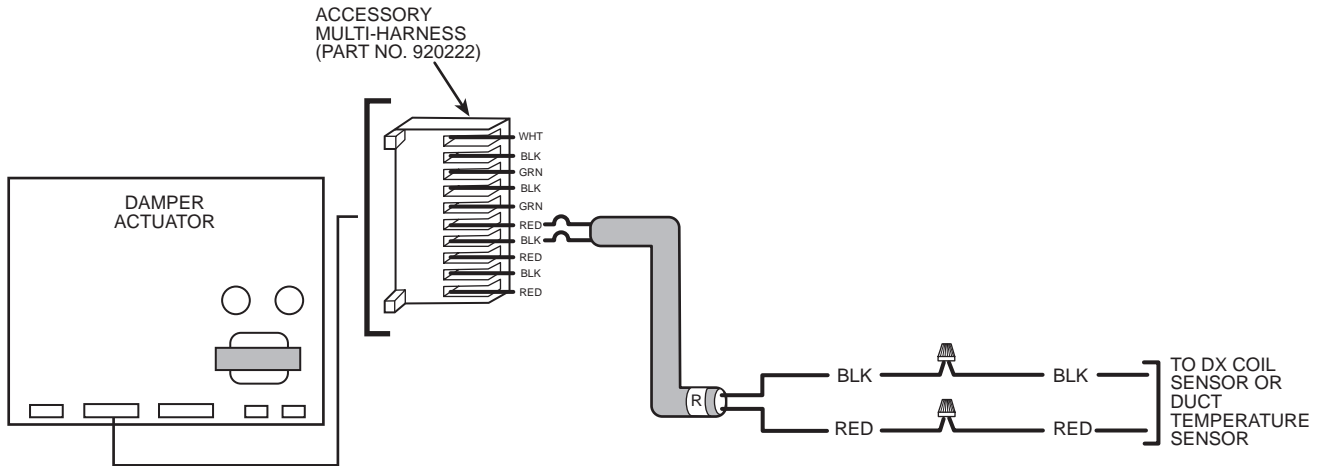
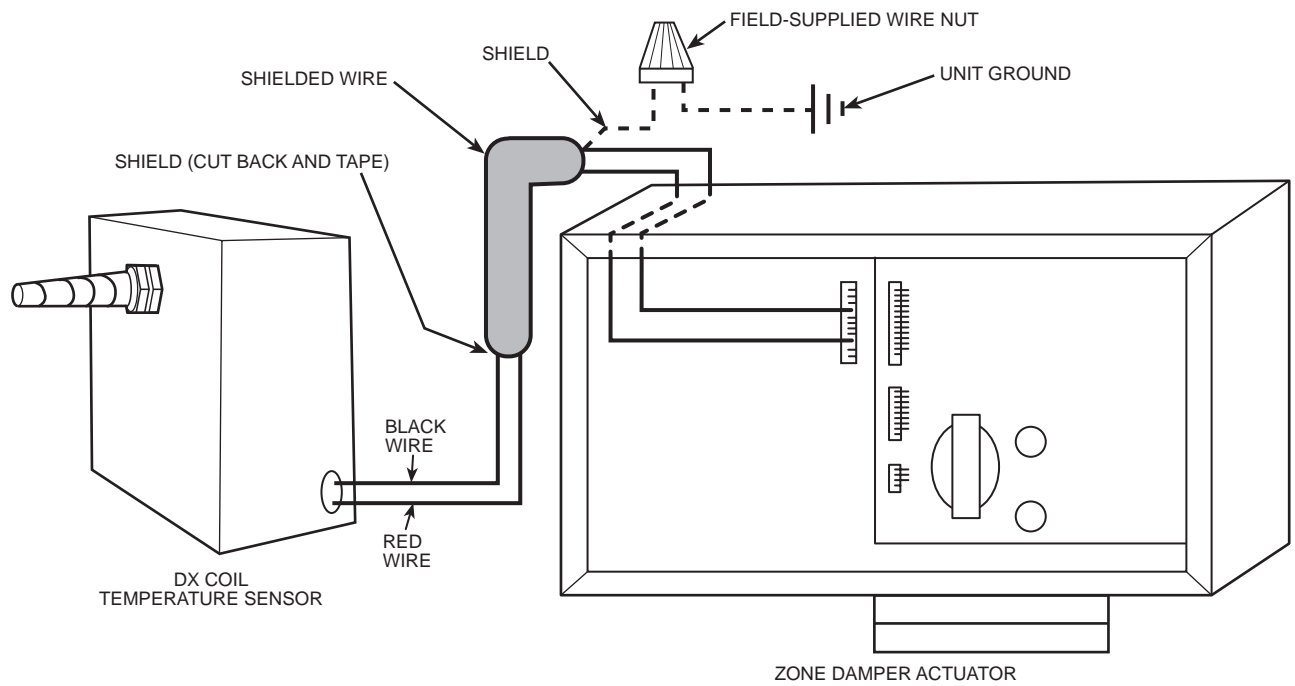

Fig. 2 — Remote Duct Sensor Installation



DX — Direct Expansion

Fig. 3 — Zone Damper Actuator Harness Wiring



LEGEND

DX — Direct Expansion

NOTE: See Fig. 3 for harness wiring details.

Fig. 4 — Wiring to Zone Damper Actuator

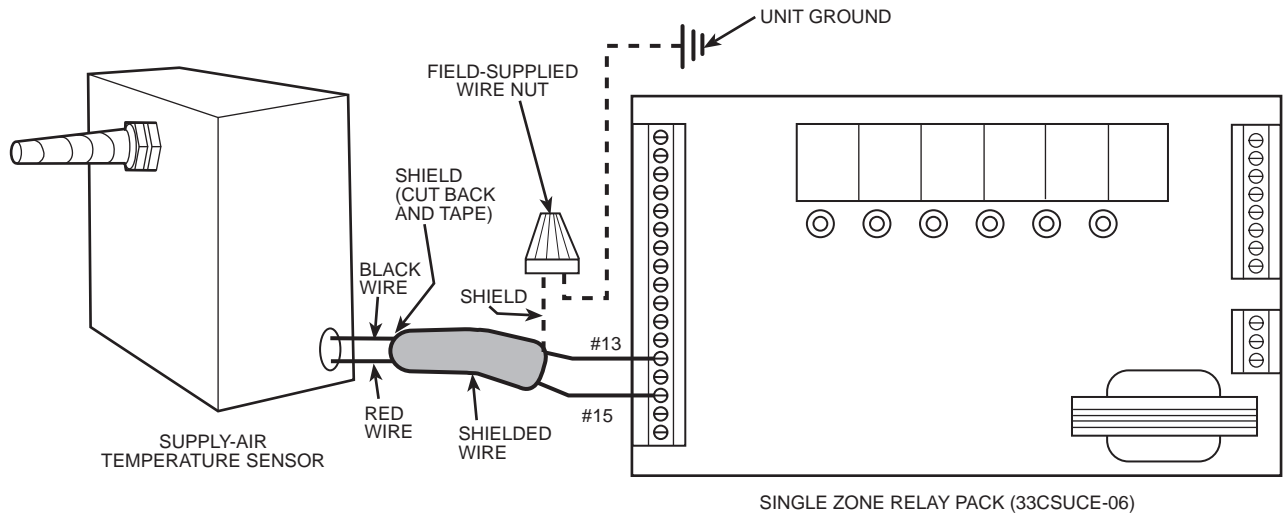
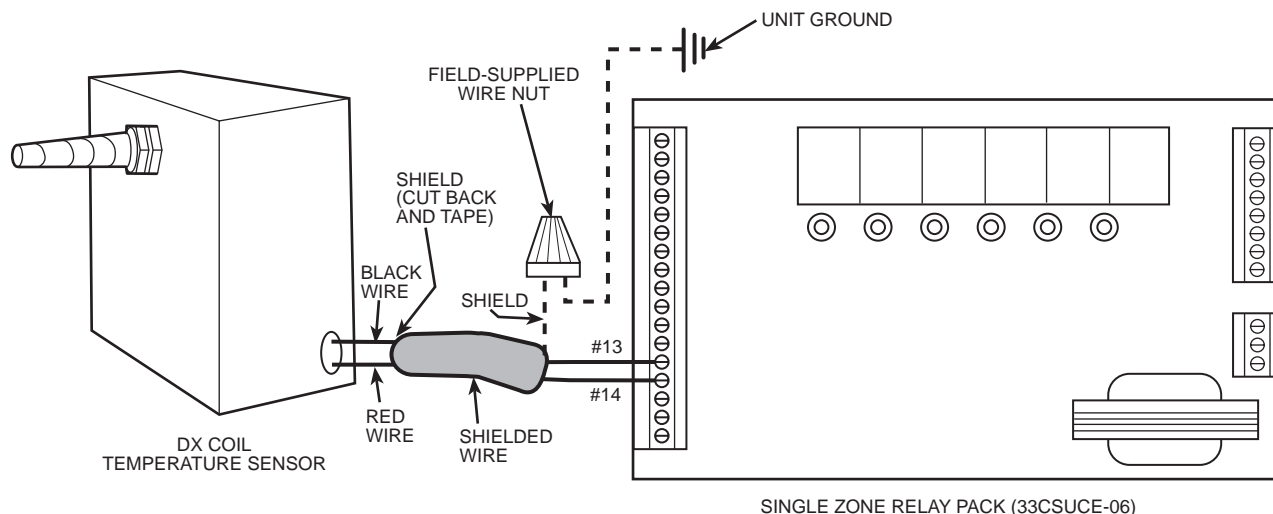

Fig. 5 — Wiring to Single Zone Relay Pack (Supply Air Sensor)



DX — Direct Expansion

Fig. 6 — Wiring to Single Zone Relay Pack (DX Coil Temperature Sensor)

Step 5 — Configure the Unit Controller

SUPPLY AIR SENSOR — When the Duct Temperature Sensor option is set to ON, the TEMP system unitary controller thermostat or VVT® monitor thermostat will monitor supply-air temperature.

When the Duct Temperature Sensor option is set to OFF, the TEMP system unitary controller thermostat or VVT monitor thermostat will not monitor supply-air temperature.

NOTE: A VVT monitor thermostat, when configured as having an associated zone (Scan Control set to 1), does NOT have the capability to turn off supply-air temperature monitoring. If the VVT monitor is configured as a monitor only (Scan Control set to 2), supply-air temperature monitoring is optional. Scan Control is set at Category 8, option 3 on the thermostat.

To configure the Duct Temperature Sensor option, configure Category 5, option 4. The option can be toggled ON or OFF. The default value is OFF.

DX COIL SENSOR — When the DX Coil Temperature Sensor option is set to ON, the TEMP system unitary controller thermostat or VVT monitor thermostat will monitor DX coil-air temperature.

When the DX Coil Temperature Sensor option is set to OFF, the TEMP system unitary controller thermostat or VVT monitor thermostat will not monitor DX coil temperature.

To configure the DX Coil Temperature Sensor option, configure Category 5, option 6. The option can be toggled ON or OFF. The default value is OFF.

Step 6 — Calibrate the Sensor

SUPPLY AIR SENSOR — To calibrate the RDS as a supply air sensor, configure category 5, option 5 on the thermostat. Obtain an accurate correct temperature reading with a thermometer near the sensor. The range of possible temperatures is 30 to 180 F. Raise or lower the RDS temperature reading until it matches the reading from the thermometer.

DX COIL TEMPERATURE SENSOR — To calibrate the RDS as a DX coil temperature sensor, configure category 5, option 7 on the thermostat. Obtain an accurate correct temperature reading with a thermometer near the sensor. The range of possible temperatures is 30 to 180 F. Raise or lower the RDS temperature reading until it matches the reading from the thermometer.