



# Installation, Start-Up, and Operating Instructions

Part Number 33CS220-LA

## CONTENTS

	Page
<b>SAFETY CONSIDERATIONS</b> .....	1
<b>GENERAL</b> .....	1
<b>INSTALLATION</b> .....	1-6
<b>Select Thermostat Location</b> .....	1
<b>Install Thermostat</b> .....	2
<b>Set Clock</b> .....	3
<b>Heat Pump Configuration</b> .....	3
<b>Configure Advanced Setup</b> .....	3
<b>Install Accessories</b> .....	4
<b>Program Thermostat Schedules</b> .....	4
<b>Calibrate Temperature Sensor</b> .....	6
<b>Light Sensor Adjustment</b> .....	6
<b>Check Thermostat Operation</b> .....	6
<b>Final Checklist</b> .....	6
<b>OPERATION</b> .....	6,7
<b>Auto-Changeover</b> .....	6
<b>Light-Activated Operation</b> .....	6
<b>Two-Stage Operation</b> .....	7
<b>Clock Backup</b> .....	7
<b>Fan Operation</b> .....	7
<b>Emergency Heat</b> .....	7
<b>Electric Heat</b> .....	7
<b>Holiday Mode</b> .....	7
<b>Keypad Lock</b> .....	7
<b>TROUBLESHOOTING</b> .....	7

## GENERAL

The 7-day, commercial, programmable thermostats are wall-mounted, low-voltage thermostats which maintain room temperature by controlling the operation of an HVAC (heating, cooling and ventilation) system. Separate heating and cooling set points and auto-changeover capability allow occupied and unoccupied programming for energy savings.

All thermostats allow up to 4 time/temperature settings to be programmed per 24-hour period. Each thermostat stores programs for 7 independent days. Batteries are not required. During power interruption the internal NEVERLOST™ memory stores programmed schedules for an unlimited time while the clock continues to run for at least 48 hours.

The thermostat can be configured to accept several different equipment configurations, including heat pump operation.

NOTE: The thermostat is not factory-configured for use in heat pump applications. The advanced setup must be performed to configure the thermostat for use with heat pump units.

A light sensor is provided on the thermostat for light activation. When the sensor detects light (the space is occupied), the thermostat will enter Occupied 1 mode. If the room is dark, the thermostat will follow its programmed schedule.

## INSTALLATION

**Select Thermostat Location** — The thermostat should be mounted:

- approximately 5 ft from the floor
- close to or in a frequently used room, preferably on an inside partitioning wall
- on a section of wall without pipes or ductwork
- where temperature operating limits are within 41 to 104 F (5 to 40 C)
- where humidity operating range is within 0 to 95% relative humidity, non-condensing

The thermostat should **NOT** be mounted:

- close to a window, on an outside wall, or next to a door leading to the outside
- where exposed to direct light and heat from a lamp, the sun, a fireplace, or any other temperature-radiating object which may cause a false reading
- close to or in direct airflow from supply registers or return air grilles
- in areas with poor air circulation (such as behind a door or in an alcove)

**IMPORTANT:** Read entire instructions before starting the installation.

## SAFETY CONSIDERATIONS

Read and follow manufacturer instructions carefully. Follow all local electrical codes during installation. All wiring must conform to local and national electrical codes. Improper wiring or installation may damage thermostat.

Recognize safety information. This is the safety alert symbol . When the safety alert symbol is present on equipment or in the instruction manual, be alert to the potential for personal injury.

Understand the signal words DANGER, WARNING, and CAUTION. These words are used with the safety alert symbol. DANGER identifies the most serious hazards which will result in severe personal injury or death. WARNING signifies a hazard which could result in personal injury or death. CAUTION is used to identify unsafe practices which would result in minor personal injury or property damage.

## Install Thermostat

### ⚠ WARNING

Before installing thermostat, turn off all power to the unit. There may be more than one power disconnect. Electrical shock can cause injury or death.

1. Turn off all power to unit.
  2. If an existing thermostat is being replaced:
    - a. Remove existing thermostat from the wall.
    - b. Disconnect wires from existing thermostat. Do not allow wires to fall back into the wall. As each wire is disconnected, record wire color and terminal connection.
    - c. Discard or recycle old thermostat.
- NOTE: Mercury is a hazardous waste and must be disposed of properly.
3. Remove the thermostat cover from wall plate (mounting base) to expose mounting holes. See Fig. 1. With the thermostat facing forward, press the back plate on the left hand side top corner to release the two prongs holding on the cover. Pull off the cover when the prongs have been disengaged.
  4. Route thermostat wires through large hole in mounting base. Remove outer sheath from wires for added flexibility. Standard solid or multi-conductor thermostat wire should be used from the thermostat to the unit. **Size and length considerations are as follows: for a maximum distance from unit of 36 ft, use 22 AWG (American Wire Gage) wire; for a maximum distance from unit of 100 ft, use 18 AWG wire.**
  5. Level mounting base against wall and mark wall through the 2 mounting holes in base.
  6. Drill two 3/16-in. mounting holes in wall where marked.

### ⚠ WARNING

Be careful not to drill into wiring in wall. Electrical shock could result.

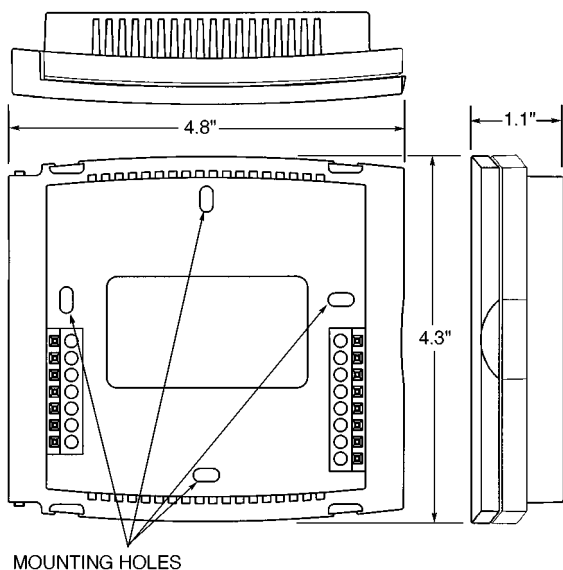

Fig. 1 — Thermostat Mounting

7. Secure mounting base to wall with 2 screws and anchors provided. Ensure all wires exit through hole in mounting base.
8. Adjust wire length and routing to allow proper closure of the thermostat. Strip each wire at the end no more than 1/4-in. to prevent adjacent wires from shorting together. Match and connect wires to terminals on the thermostat. See Fig. 2-4 and Table 1.

### ⚠ CAUTION

Improper wiring or installation may cause damage to the thermostat. Check to ensure wiring is correct before proceeding with installation of unit.

9. Push excess wiring into wall. Seal hole in wall to prevent drafts.
10. Re-attach thermostat cover to back plate by aligning the top two prongs of the back plate in the vertical groove of the top cover and then snapping the cover onto the back plate.
11. Turn on power to unit. The thermostat will receive power from the unit. The thermostat will be powered by 24 v, nominal (18 to 30 vac). Terminals R (+ 24 v), W1/O/B (first stage heat or reversing valve), Y1 (first stage cooling), and G (fan relay) will always be connected. Some applications will use C (common), Y2 (second stage cooling), or W2 (second stage heating).

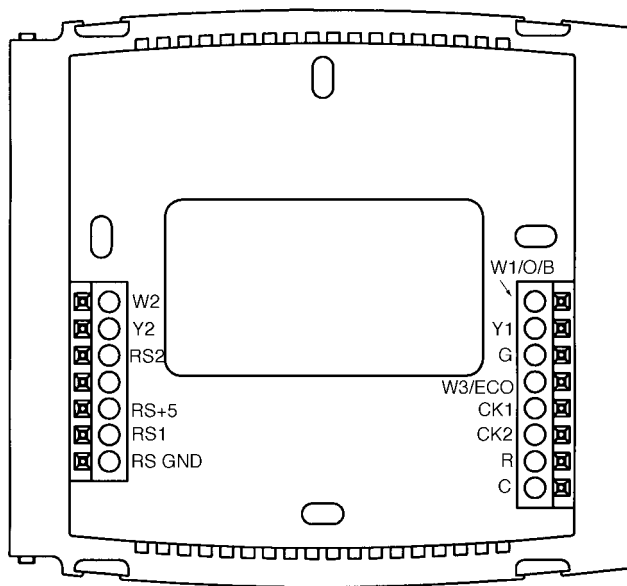

#### LEGEND

<b>W2</b> — Second-Stage Heat	<b>W1/O/B</b> — First-Stage Heat or Reversing Valve
<b>Y2</b> — Second-Stage Compressor	<b>Y1</b> — First-Stage Compressor
<b>RS2</b> — Not Used	<b>G</b> — Fan
<b>RS+5</b> — Not Used	<b>W3/ECO</b> — Third-Stage Heat or Economizer (Not Used)
<b>RS1</b> — Not Used	<b>CK1</b> — Not Used
<b>RS</b> — Not Used	<b>CK2</b> — Not Used
<b>GND</b>	<b>R</b> — 24 vac Transformer
	<b>C</b> — 24 vac Transformer Common

Fig. 2 — Thermostat Wiring

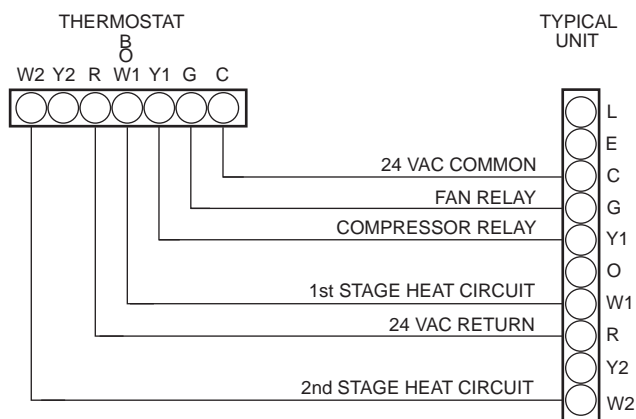

**Fig. 3 — Typical Wiring (Single-Stage Cooling Units)**

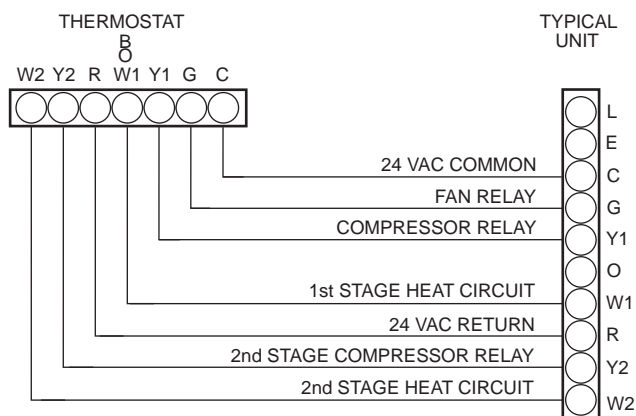

**Fig. 4 — Typical Wiring (Two-Stage Cooling Units)**

**Table 1 — Thermostat Wiring Terminations**

EXISTING WIRE DESIGNATION	FUNCTION	TERMINAL CONNECTION
G or F	Fan	G
Y1, Y, or C	Cooling	Y1
W1, W, or H	Heating	W1/O/B
Rh, R, M, Vr, or A	Power (24 v)	R
C	Common	C*
O/B	Reversing Valve	W1/O/B†
Y2	Second Stage Cooling	Y2*
W2	Second Stage Heating	W2*

\*Terminals C, W2, and Y2 may not be used in all applications.  
 †Used on Heat Pump applications only.

**Set Clock** — The Set Clock button allows the user to change the time and day displayed on the thermostat. Press the Set Clock button. The current time will blink on and off. Press the UP ARROW and DOWN ARROW buttons until the correct time is shown. Hold down the buttons to quickly move through the time display. The AM and PM annunciators will automatically change. Hold down the Fan button while pressing UP ARROW or DOWN ARROW to change the time by hours instead of minutes. To ensure the schedules are properly followed, make sure that AM or PM is correct for the time chosen. When the correct time is shown, press the Mode button to modify the day of the week. The current day will

blink on and off. Press the UP ARROW and DOWN ARROW buttons until the correct day is shown. Press the Set Clock button again to exit the Set Time mode.

**Heat Pump Configuration** — To configure the thermostat for heat pump operation, Advanced Setup Steps 3 (Heat Pump Operation) and 4 (Reversing Valve Polarity) must be configured correctly. See the Configure Advanced Setup section for information on configuring these options.

NOTE: Some large commercial rooftop heat pump units (50HJQ, TJQ, EJQ) must be configured with Advanced Setup Step 3 (Heat Pump Operation) set to OFF. Refer to the base unit instructions for more information.

**Configure Advanced Setup** — To enter into the advanced setup screens of the thermostat, press the Mode and Program buttons at the same time. The Advanced Setup Step number is shown in the top right corner of the thermostat screen. Use the Mode button to advance through the steps. There are 15 Advanced Setup Steps. See Table 2. Press the Program button at any time to exit the Advanced Setup mode.

NOTE: Advanced Setup Steps 1 and 2 are configured with the Set Clock button, and are not accessed through the advanced setup screens.

**HEAT PUMP CONFIGURATION (Steps 3 and 4)** — To set the thermostat for heat pump operation, Advanced Setup Step 3 must be configured to ON. Use the UP and DOWN ARROW buttons to configure the step. The default is OFF. Press the mode button to continue to Step 4. Step 4 is used to set the reversing valve polarity for the heat pump. The variable can be set to either “B” or “O.” Set the reversing valve polarity to the correct value depending on the application. The default is “O.”

NOTE: Step 4 will appear only if Step 3 is set to ON. Step 5 will appear only if Step 3 is set to OFF.

**ELECTRIC HEAT CONFIGURATION (Step 5)** — Step 5 is used to configure the thermostat for electric heat. The variable can be configured ON or OFF. The default is OFF.

NOTE: Step 5 will appear only if Step 3 is set to OFF.

**Table 2 — Advanced Setup Configuration**

STEP	DESCRIPTION	RANGE	DEFAULT
1*	Time of Day	12:00 AM - 11:59 PM	12:00 AM
2*	Day of the Week	Sunday through Saturday	Monday
3	Heat Pump	Off/On	Off
4	Reversing Valve Polarity	O/B	O
5	Electric Heat	Off/On	Off
6	Deadband	1 - 6 degrees	2
7	Forced Minimum Temperature Difference	0 - 6 degrees	2
8	Cycles per Hour	d, d1, 2 - 6	6
9	Thermoglow™ Backlight	Off/On	On
10	Reset Service Filter Icon	—	—
11	Service Filter Run Time	0-1950 hrs	500 hrs
12	Temperature Units	F/C	F
13	Security Level	0 - 3	0
14	Maximum Allowable Heat Set Point	35 - 99 F (1-37 C)	80 F (27 C)
15	Minimum Allowable Cooling Set Point	35 - 99 F (1-37 C)	65 F (18 C)

\*Accessed and configured through the Set Clock button.

**DEADBAND (Step 6)** — The deadband is the difference in temperature above the cooling set point or below the heating set point that the thermostat will wait before turning on the first stage of heating or cooling. For example, if the cooling set point is 82 F (28 C) and the deadband is 2 degrees, the first stage of cooling will not be energized until the temperature reaches 84 F (30 C). The range of values is 1 to 6 degrees. The default is 2 degrees.

**SET POINT MINIMUM DIFFERENCE (Step 7)** — The minimum difference between heating and cooling set points can be user-configured. The range is from 0 to 6 degrees. The default is 2 degrees. The minimum difference is enforced during Auto-Changeover and Program On operation.

**CYCLES PER HOUR LIMIT (Step 8)** — The number of times that heating or cooling can be energized per hour can be configured. Set the variable to “d” for no limit. Set the variable to “d1” to disable the 5-minute compressor lockout. The variable can also be set from 2 to 6 cycles per hour. The default is 6 cycles per hour.

**▲ CAUTION**

Damage to compressor could result if 5-minute compressor lockout is disabled or compressor is allowed unlimited cycles. Do not set thermostat Advanced Setup Step 8 to “d” or “d1” unless specifically recommended for the application.

**BACKLIGHT DISPLAY (Step 9)** — The display backlight can be set to ON (always on) or OFF (turn off 8 seconds after usage). The default is ON.

**SERVICE FILTER (Steps 10 and 11)** — Step 10 allows the user to reset the Service Filter counter to zero and remove the “SERVICE FILTER” icon (if displayed on the thermostat screen). Press the FAN button while in Setup Step 10 and the counter is reset to zero. Press the Mode button to adjust the number of hours the blower will run before the “SERVICE FILTER” icon is displayed. The range is 0 to 1950 hours. Set the variable to 0 to disable this function. The default is 500 hours.

**FAHRENHEIT/CELSIUS OPERATION (Step 12)** — The thermostat can be set to operate in Fahrenheit or Celsius degrees. Set the variable to “F” for Fahrenheit operation. Set the variable to “C” for Celsius operation. The default is “F.”

**SECURITY LEVEL (Steps 13 to 15)** — The Security Level limits the actions that the user can perform at the thermostat. There are 4 security levels. When the security level is set to “0,” no security will be in effect. When the security level is set to “1,” the set point range is limited by the settings of Steps 14 and 15. When the security level is set to “2,” the set point range is limited by the settings of Steps 14 and 15 and the Program On mode is always in effect. When the security level is set to “3,” the set point range is limited by the settings of Steps 14 and 15, the Program On mode is always in effect, and set point changes are prohibited. The default is 0.

**Security Maximum Heat Set Point (Step 14)** — If the Security Level is not set to 0, the maximum heating set point will be in effect. The user will not be allowed to set the heating set point over the specified value. The range of values is 35 to 99 F (1 to 37 C). The default is 80 F (27 C).

**Security Minimum Cool Set Point (Step 15)** — If the Security Level is not set to 0, the minimum cooling set point will be in effect. The user will not be allowed to set the cooling set point below the specified value. The range of values is 35 to 99 F (1 to 37 C). The default is 65 F (18 C).

**Install Accessories** — The following accessory can be used with this thermostat: Add-a-Wire™ accessory (33CSACC-AW).

Refer to the accessory installation instructions for the accessory for more information.

**Program Thermostat Schedules** — Before programming the thermostat, plan the thermostat daily schedule. The schedule is divided into 7 days (Monday through Sunday). Each day has from 2 to 4 time periods (Occupied 1, Occupied 2, Occupied 3, Unoccupied) depending on the configuration of the thermostat. Each occupied time period has a start time, stop time, heating set point, and cooling set point. The unoccupied time period has a heating set point and a cooling set point. The unoccupied time period is active when ever an occupied time period is not active. Fill in Table 3 as an aid to programming the daily schedules.

**NOTE:** When the sensor detects light (the space is occupied), the thermostat will enter Occupied 1 mode. If the room is dark, the thermostat will follow its programmed schedule. The Occupied 1 schedule should be turned OFF to keep the thermostat from entering Occupied 1 while the room is unoccupied. If the Occupied 1 schedule is turned ON, the thermostat will enter Occupied 1 per the schedule regardless of light activation. The Occupied 1 set points are used as the heating and cooling set points during light activation. The Unoccupied set points should be used as non-work hour set points (before 8:00 AM and after 5:00 PM) when using light activation. For times when the building is unoccupied during work hours (Monday through Friday, 8:00 AM to 5:00 PM), the Occupied 2 schedule should be turned ON, and can be used for moderate energy savings with set points of 80 F for cooling and 65 F for heating.

**PROGRAMMING MODE** — To program the daily schedules, perform the following procedure:

1. Enter programming mode by pressing the Program button. The Occupied 1 annunciator will appear on the thermostat display. Use the UP ARROW and DOWN ARROW buttons to set the maximum number of Occupied periods for each day. The thermostat can be set to 1, 2, or 3. After the number of Occupied periods has been selected, press the Mode button. See Fig. 5.
2. The cooling set point for Occupied 1 will be displayed. Use the UP ARROW and DOWN ARROW buttons to raise or lower the cooling set point until the desired temperature is shown. The range of acceptable values is 35 to 99 F (1 to 37 C). Press the Mode button to continue. See Fig. 5.
3. The heating set point for Occupied 1 will be displayed. Use the UP ARROW and DOWN ARROW buttons to raise or lower the heating set point until the desired temperature is shown. The range of acceptable values is 35 to 99 F (1 to 37 C). Press the Mode button to continue. See Fig. 5.

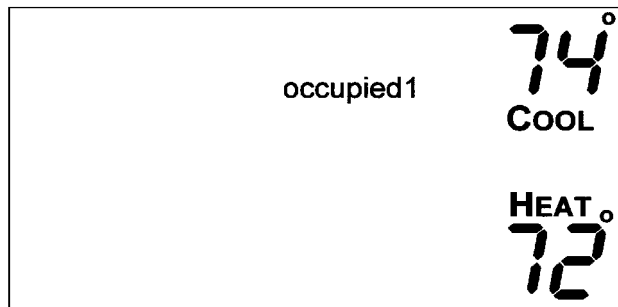

**Fig. 5 — Setting Occupied 1 Set Points**

**Table 3 — Daily Schedule Planner**

DAY OF THE WEEK	SCHEDULE			
	Occupied 1	Occupied 2	Occupied 3	Unoccupied
	Start / Stop / Heat / Cool	Start / Stop / Heat / Cool	Start / Stop / Heat / Cool	Heat / Cool
Monday	/ / /	/ / /	/ / /	/
Tuesday	/ / /	/ / /	/ / /	/
Wednesday	/ / /	/ / /	/ / /	/
Thursday	/ / /	/ / /	/ / /	/
Friday	/ / /	/ / /	/ / /	/
Saturday	/ / /	/ / /	/ / /	/
Sunday	/ / /	/ / /	/ / /	/

NOTE: The cooling temperature set point must be higher than the heating temperature set point. (The temperature difference may be changed in the advanced setup configuration.)

- The cooling set point for Unoccupied will be displayed. Use the UP ARROW and DOWN ARROW buttons to raise or lower the cooling set point until the desired temperature is shown. The range of acceptable values is 35 to 99 F (1 to 37 C) or “OF” (no unoccupied cooling). Press the Mode button to continue.
- The heating set point for Unoccupied will be displayed. Use the UP ARROW and DOWN ARROW buttons to raise or lower the heating set point until the desired temperature is shown. The range of acceptable values is 35 to 99 F (1 to 37 C) or “OF” (no unoccupied heating). Press the Mode button to continue.
- The day of the week will be shown. Use the UP ARROW and DOWN ARROW buttons to change the day of the week until the desired starting day is shown. Possible choices are M (Monday) through S (Sunday). Press the Mode button when the desired day is shown.
- The Start Time for Occupied 1 will be displayed. Use the UP ARROW and DOWN ARROW buttons to raise or lower the time until the desired Start Time is shown. Press the Mode button to continue. See Fig. 6.
- The Stop Time for Occupied 1 will be displayed. Use the UP ARROW and DOWN ARROW buttons to raise or lower the time until the desired Stop Time is shown. Press the Mode button to continue.
- The On/Off icon will be displayed. Use the UP ARROW to turn the Occupied 1 period ON for this day. Use the DOWN ARROW to turn the Occupied 1 period OFF for this day.
- Repeat Steps 2 through 9 to program the remaining schedule for Occupied periods 2 and 3.
- The Copy command can be used to copy the previous day’s schedule if the schedules are the same. The copy command becomes available after all the occupied periods are programmed in a day. Use the UP ARROW to change the copy command to YES. Use the DOWN ARROW to change the copy command to NO. Press the Mode button when the choice has been made. See Fig. 7.  
If NO was selected, the schedule will automatically change to the next day and the user must enter the occupied and unoccupied schedules for that day.  
NOTE: Occupied 1 schedule heating and cooling set points are the same for each day. Occupied 2 and 3 set points may be set to different values for each day of the week.  
If YES was selected, the schedule will be copied to the next day. The schedule copy may be repeated until Sunday is reached. The Sunday schedule cannot be copied to Monday.
- After all the times and set points for each day have been entered, press the Program button to exit programming mode.

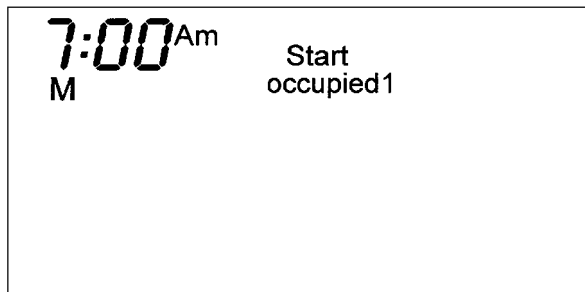

**Fig. 6 — Start Time Display**

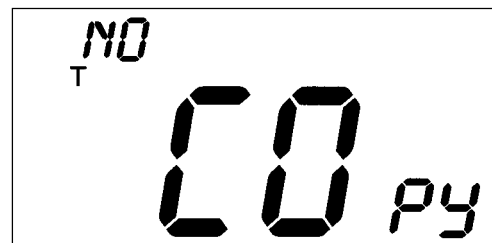

**Fig. 7 — Copy Command Display**

NOTE: The thermostat will continue to follow the schedule until a new one is entered.

If only one occupied schedule is selected, the Occupied 2 and 3 schedules are skipped. If the start time is set later in the day than the stop time, the program will run from midnight of that day to the stop time and then from the start time to midnight. If the same start and stop times are programmed for an occupancy schedule, the thermostat will be in Occupied mode for 24 hours. If one occupied period starts or stops within another occupied period, the lower numbered schedule has priority. For example, if schedule Occupied 3 is running for 24 hours and Occupied 2 schedule comes on from 1 to 3 PM, the set points from Occupied 2 are in effect from 1 to 3 PM.

**OVERRIDING THE SCHEDULE** — The schedule can be overridden by pressing the UP or DOWN ARROW buttons to change the desired temperature. The thermostat will use the new set point until the next scheduled time period starts.

**Calibrate Temperature Sensor** — Every thermostat is factory calibrated. Under normal circumstances there will never be a need to re-calibrate the thermostat. If re-calibration must be done, perform the following procedure:

1. Hold down the Mode and Fan buttons for 5 seconds. All of the icons on the display screen will appear. Release the buttons. Press the UP and DOWN ARROW buttons simultaneously.
2. Press the UP and DOWN ARROW buttons simultaneously again. The current temperature will be displayed.
3. Use an accurate thermometer to measure room temperature. Press the UP or DOWN ARROW buttons until the number equals room temperature.
4. Press the Mode button to return to normal operation.

**Light Sensor Adjustment** — The light sensor is used for light-activated operation. The sensor can be adjusted for a variable degree of sensitivity. The sensitivity adjustment screw is located on the inner cover of the thermostat, near the DOWN ARROW button. Turning the screw clockwise increases the sensitivity of the sensor to light. Turning the screw counterclockwise decreases the sensitivity of the sensor to light.

To check for correct sensitivity, place the thermostat in Program On mode. The thermostat should be in Occupied 1 when the lights are on. If the sensor does not enter Occupied 1 while the lights are on, turn the screw clockwise until the Occupied 1 icon appears on the display. The thermostat should enter Unoccupied mode when the lights are off. If the sensor does not enter Unoccupied when the lights are turned off, turn the screw counterclockwise until the Unoccupied icon appears on the display.

**IMPORTANT:** An external device should not be used with the dry contact switch with light activated operation. The light sensor is wired to the dry contact switch. Another device will cause conflicting signals to the thermostat. The RED wire of the sensor is wired to CK1. The BLACK wire of the sensor is wired to CK2.

**Check Thermostat Operation** — To check thermostat operation, perform the following procedure:

1. Press the Mode button repeatedly until the Heat icon appears on the display. The thermostat is now in Heating mode.
2. Press the Fan button. The Fan Auto icon will appear on the display screen. Press the UP ARROW button until the heating set point is 10 F (6 C) higher than the current room temperature. Heating and fan should be energized.
3. Press the Mode button repeatedly until the Cool icon appears on the display. The thermostat is now in Cooling mode.
4. Press the DOWN ARROW button until the cooling set point is 10 F lower than the current room temperature. Cooling and fan should be energized.
5. Press the Mode button repeatedly until the Off icon appears. Press the Fan button until the display reads Fan On. The fan should energize.
6. If heating, cooling, or fan operation do not work, check wiring and consult Table 4.

### Final Checklist

1. Put away tools and instruments. Clean up debris and packaging.
2. Review Owner's Guide with occupant or owner.
3. Leave the manuals with owner.

### OPERATION

The Mode button selects the operating mode of the thermostat. If OFF is selected, the thermostat will not enter Heating or Cooling mode. If HEAT is selected, the thermostat will only enter Heating mode (if the room temperature is below the heating set point). If COOL is selected, the thermostat will only enter Cooling mode (if the room temperature is above the cooling set point). If AUTO is selected, the thermostat will enter Heating or Cooling mode based on the room temperature and the heating and cooling set points. If PROGRAM ON is selected, the stored schedule is enabled and the thermostat will follow the Occupied and Unoccupied schedules stored in its memory.

**Auto-Changeover** — When the thermostat mode is set to AUTO, the thermostat will provide automatic changeover from Heating to Cooling mode and Cooling to Heating mode when required. The thermostat will automatically switch to maintain the desired temperature setting. The thermostat does not need to be manually changed from heating to cooling or cooling to heating operation.

**Light-Activated Operation** — A light sensor is provided on the thermostat for light activation. The thermostat must be in Program On mode for light activation to be initiated. When the sensor detects light (the space is occupied), the thermostat will enter Occupied 1 mode and heat or cool according to the Occupied 1 set points. If the room is dark, the thermostat will follow its programmed schedule.

NOTE: Light activation does not work in Holiday mode.

**Two-Stage Operation** — The second stage of heat or cool is turned on when the first stage has been on for a minimum of 2 minutes and the temperature differential from the set point is equal to or greater than the set point plus the deadband plus 2 degrees.

**Clock Backup** — In the event of a power loss, the thermostat will keep time for a minimum of 48 hours without external power or batteries.

**Fan Operation** — If Fan On is selected, the fan will run continuously during occupied schedule (except when Mode is switched to OFF). The fan will be off during unoccupied schedule except during heating or cooling operation.

If Fan On is not selected, the fan will only operate during heating or cooling operation.

**Emergency Heat** — Emergency heat is available for heat pump applications. To turn on emergency heat, press and hold the Fan button. While holding the Fan button, press the UP button for 2 seconds. An “EH” will be displayed. During emergency heat, the fan will operate and the second stage of heat will be energized (locking out the first stage compressor). To exit emergency heat, press and hold the Fan button. While holding the Fan button, press the UP button for 2 seconds. During emergency heat, only OFF and HEAT modes are available.

**Electric Heat** — When the Electric Heat option in the advanced set up is set to ON (configured by installer), the thermostat will turn on the fan immediately any time there is a heat demand. This feature should only be used on electric heating applications. Do not use with gas heat.

**Holiday Mode** — When the thermostat is in Holiday mode, the thermostat will operate under Unoccupied set points. To configure and activate the Holiday mode, press the Holiday button. The “HOL” icon will be displayed along with the remaining days of Holiday mode operation. Press the UP or DOWN ARROWS to select the number of days that the holiday schedule will be in effect. A value of 0 disables Holiday mode. The duration can be set from 1 to 99 days. The thermostat will enter Holiday mode on midnight of the next day after the mode has been activated. Holiday mode will remain in effect until midnight of the last configured day.

If the Holiday mode is in effect, the number of days remaining will blink on and off and the “Unoccupied” icon will be displayed. The Override button will be active during Holiday mode.

To turn off the Holiday mode before the remaining configured days have passed, press the Holiday button to enter into the configuration mode. Press the DOWN ARROW to set the number of days to zero. Holiday mode will be disabled.

**Keypad Lock** — To prevent unauthorized use of the thermostat, the front panel buttons can be disabled. To disable or lock the keypad, press and hold the Mode button. While holding down the Mode button, press the UP and DOWN ARROW buttons simultaneously. The “Locked” icon will appear on the display.

The thermostat is unlocked by performing the same procedure. Press and hold the Mode button. While holding down the Mode button, press the UP and DOWN ARROW buttons simultaneously. The “Locked” icon will be removed from the display.

## TROUBLESHOOTING

**Table 4 — Thermostat Troubleshooting**

PROBLEM	SOLUTION
Display on thermostat not illuminated.	Check for 24 vac at the R terminal connection. Terminal R must be connected for proper thermostat operation.
“Service Filter” is displayed on thermostat.	After the configured number of blower operating hours, the Service Filter message will be displayed. This reminds the owner to replace the filter. Reset the Service Filter feature to reset the blower operation timer to 0 hours.
Cooling will not energize.	Select COOL mode. Decrease cooling set point to 10 degrees below room temperature. Check for 24 vac at Y1 terminal. If present, thermostat is operating correctly and problem is with wiring or equipment. If 24 vac is not present, replace the thermostat. Check for Compressor Cycle per Hour Limit. Cooling may be locked out.
Heating will not energize.	Select HEAT mode. Increase heating set point to 10 degrees above room temperature. Check for 24 vac at W1/O/B terminal. If present, thermostat is operating correctly and problem is with wiring or equipment. If 24 vac is not present, replace the thermostat.
When using 4 wires (R,G,W,Y), the cooling equipment tries repeatedly to turn on, but cannot. At times the display dims or disappears.	There is not enough power available. Connect a 270 ohm, 10 watt power resistor at the air-conditioning equipment between terminals W and C (non-heat pump applications only).
When using 4 wires (R,G,W,Y), the heating equipment tries repeatedly to turn on, but cannot. At times the display dims or disappears.	There is not enough power available. Connect a 270 ohm, 10 watt power resistor at the air-conditioning equipment between terminals Y and C (non-heat pump applications only).
When controlling a heat pump, heat comes on during cooling cycle.	Configure thermostat for heat pump operation (Table 2, Step 3).
When calling for cooling, both heating and cooling are energized.	The thermostat is configured for a heat pump. Configure the thermostat for non-heat pump operation (Table 2, Step 3).
When controlling a commercial heat pump unit, unit runs in reverse or heating is always on.	Commercial heat pumps require that Heat Pump Option on thermostat is turned OFF.

