



Installation Instructions

Part Numbers 33CSDCA060 and 33CSDCA090

PACKAGE USAGE AND CONTENTS

| USAGE | PACKAGE NO. | CONTENTS |
|---|-------------|----------------------------------|
| Damper with 60 degree rotation required | 33CSDCA060 | High Torque Damper Actuator* |
| | | Mounting Bracket |
| | | Grommet |
| | | Two 1/4-in. self drilling screws |
| Damper with 90 degree rotation required | 33CSDCA090 | High Torque Damper Actuator* |
| | | Mounting Bracket |
| | | Grommet |
| | | Two 1/4-in. self drilling screws |

*The following are wired and installed on the high torque actuator:
 15-in. wire harness with 5-pin connector for thermostat connection
 15-in. wire harness with 3-pin connector for power connection
 36-in. wire harness with duct temperature sensor

GENERAL

The accessory direct-drive high torque actuators are used in VVT® (Variable-Volume/Variable Temperature) systems for changing the damper position. The actuators are installed on zone dampers and are controlled by a zone controller or a monitor thermostat. The monitor thermostat calculates how much heating or cooling is required to each zone in the VVT system. The actuator receives the commands from its controlling device and moves its damper to change the amount of heated or conditioned air that is sent to its zone.

High torque actuators are available in 60 or 90 degree rotation types to match the damper on which it is used.

IMPORTANT: Read these instructions completely before attempting to install the accessory high torque actuator.

INSTALLATION

⚠ WARNING

Electrical shock can cause injury or death. Remove all power to transformer and thermostat before wiring the actuator.

Step 1 — Install Actuator on Damper

1. The High Torque Actuator has the following environmental requirements:
 - Power: 24 VAC ± 15%, Class 2
 - Temperature: 0° to 60 C or 32 to 140 F
 - Humidity: 10 to 95% Relative Humidity Non-Condensing

NOTE: The va requirements are:

- 30 va for damper actuators only. (Not interfaced to relay packs or pressure sensors.)
 - No ADDITIONAL VA required for damper actuators interfaced to a 33CSZRP-06 Universal Relay Pack.
 - An ADDITIONAL 5 VA required for damper actuators interfaced to a 33CSPS-XX pressure sensor.
 - Additional 5 VA required for HR03 or CHR06 relay pack.
2. The following field-supplied tools and parts are required for installation:
 - 5/32-in. Allen wrench
 - Phillips head screw driver
 - battery-powered drill with 1/4-in. nut driver bit
 3. Remove the actuator cover by loosening the two screws on each side of the cover and pulling the cover up off the actuator body. Save screws. See Fig. 1.
 4. The actuator drive assembly and position indicator will now be visible. The actuator is shipped with the indicator on 0 degrees. The drive assembly will rotate counterclockwise to 60 degrees (33CSDCA060) or 90 degrees (33CSDCA090). Per the application and damper, determine which direction the damper shaft must rotate to open. If the damper that the actuator is being installed on rotates counterclockwise to open, then follow the directions below for counterclockwise rotation. If the damper that the actuator is being installed on rotates clockwise to open, then follow the directions below for clockwise rotation.

Counterclockwise Rotation:

Turn the shaft fully clockwise until the damper is closed.

Clockwise Rotation:

- a. Power the actuator with 24 VAC and connect the actuator to a Zone Controller or Monitor Thermostat using the 5-pin connector.
- b. Configure the Zone Controller or Monitor Thermostat for ZD/RD actuator OFF, and Clockwise Open OFF.
- c. Use the Zone Controller or Monitor Thermostat to command the actuator to 0 damper position by using the Position Damper command or setting the minimum damper position to zero and satisfying temperature demand. The indicator on the actuator should turn to the 60-degree (33CSDCA060) or 90-degree (33CSDCA090) position and stop.
- d. Disconnect power and rotate the shaft on the damper fully counterclockwise until the damper is closed.

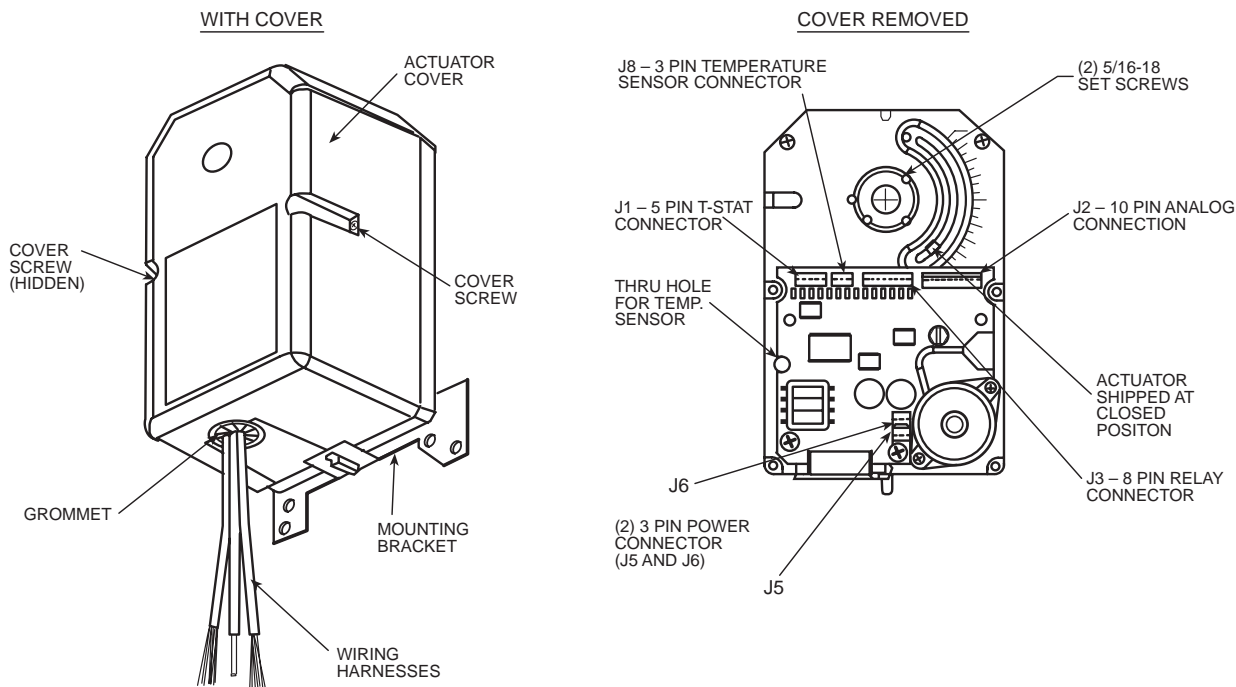

Fig. 1 — High Torque Actuator

5. Slide the actuator over the damper shaft until it comes to rest against the wall of the damper assembly. Make sure the actuator body is free from any obstructions and that there is room to install the mounting bracket at the bottom of the actuator. See Fig. 2 for actuator dimensions.
6. Install the mounting bracket by sliding the long rectangular portion of the bracket under the actuator body. The slot on the bracket should slide over the nipple on the bottom of the actuator and the tabs with the screw holes should be pointing away from the actuator. See Fig. 3.
7. Secure the bracket to the damper wall assembly with two self-drilling tech screws (provided). Make sure the screws will not interfere with damper operation.
8. Tighten the two Allen screws on the actuator spindle securing it to the damper shaft, making sure the damper is still in the closed position.
9. Replace the actuator cover and secure it with the two screws removed from Step 3.

IMPORTANT: If a relay pack or additional sensors are required for the application, install the relay pack and additional sensors before wiring the actuator.

Step 2 — Relay Pack Installation — The relay pack (Part Number 33CSZRP-06) may be required on some applications. The relay pack is ordered separately from the damper actuator. Refer to the relay pack installation instructions for more information.

IMPORTANT: Before installing the relay pack make sure the damper shaft will not come in contact with the relay pack once it is installed inside the actuator cover. If the shaft will touch the relay pack, the damper shaft must be cut to bring it flush with the sleeve of the actuator.

1. Locate the four standoffs inside the actuator cover which have the plastic inserts inside. (The holes will be smaller.) Align the relay pack, with the four screw holes over the standoffs with the smaller holes. See Fig. 4.
2. Secure the relay pack in place using the four Phillips head screws provided with the relay pack.

3. Connect the 3-pin power wire harness (J5 or J6) on the actuator to the power terminal on the relay pack. The power connection on the relay pack is the only three-prong connector on the relay pack.
4. Connect the 8-pin connector of the wiring harness provided with the relay pack to the 8-pin connection on the relay pack (the connector at the same end of the relay pack as the 24 VAC connector) and to the 8-pin terminal on the actuator J3 (directly below the damper spindle).
5. Connect the relay pack output harness to the output connector on the relay pack, then thread the pigtail through the grommet at the bottom of the actuator.
6. Connect the relay pack output harness to the appropriate colored wires from the HVAC equipment using field-supplied wire nuts. See the relay pack Installation Instructions for more information on the wire colors needed.

Step 3 — Additional Sensor Installation — If additional sensors are used, follow the installation procedure below. Refer to the sensor or thermostat installation instructions for more information.

1. Connect the multi-sensor harness (purchased separately, Part Number 920222) or pressure sensor harness (purchased separately, Part Number 920286) to the 10-pin connector in the upper right hand corner of the actuator circuit board. See Fig. 5 and 6.

NOTE: Sensor harnesses can be ordered through Commercial Products Systems and Controls Price Pages.

2. Feed the sensor pigtails through the grommet at the bottom of the actuator. Grommet hole is $\frac{5}{16}$ -in. diameter.
3. Make all connections to sensors outside the actuator housing. Be sure to cap off any unused wires to prevent grounding or shorting the wires. Check the appropriate thermostat installation and troubleshooting guide for sensor application information.

NOTE: The pressure sensor cannot be installed inside the actuator housing. There is no clearance available for the pressure transducer inside the actuator.

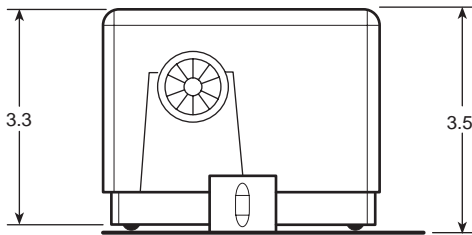
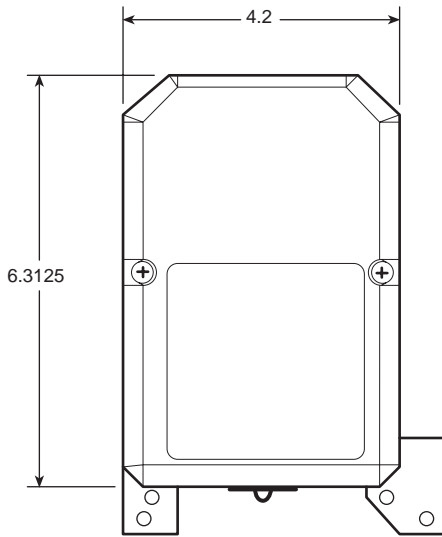

NOTE: All dimensions are in inches.

Fig. 2 — Actuator Dimensions

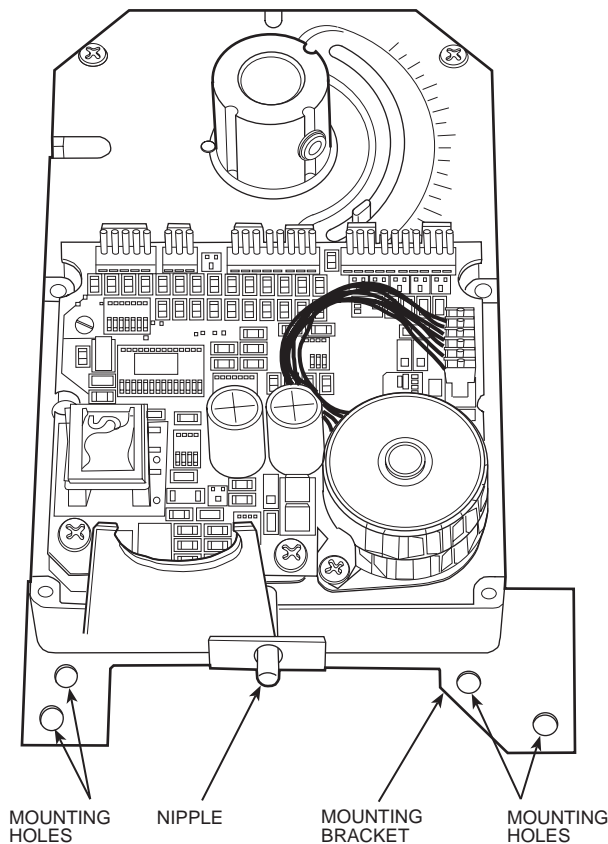

Fig. 3 — Mounting Bracket Installation

Step 4 — Actuator Wiring — The actuator comes with 3 wiring harnesses attached: the duct sensor with wiring harness, 5-pin thermostat connector (J1), and the 3-pin power harness (J8). See Fig. 1. All connections should be made outside of the actuator body as there is not enough room inside the actuator when the cover is on. There is also the danger that some of the loose wires could get entangled in moving parts inside the actuator housing.

⚠ CAUTION

Never run actuator wiring near any cable carrying AC voltage. Other cables could cause interference with actuator, causing unit damage.

If conduit is used, replace the black grommet with a 1/2-in. T condolet or covered junction box. The connections will be made inside the condolet or junction box. Use the grommet provided with the actuator to cover a knockout on the junction box. This will allow the duct sensor wire to penetrate the junction box for installation of the duct sensor. The duct sensor has plenum wire rating and may be run exposed in a plenum.

To wire the actuator, perform the following:

1. The duct sensor is used to sense the temperature of the air coming from the primary air source. Drill a 5/16-in. hole in the duct, upstream of the damper. Install the sensor. Failure to locate the sensor upstream of the damper could result in erratic control of damper especially when using dampers with supplemental heat. Use the grommet included with the actuator to protect the sensor wire from the sheet metal edge of the hole.
2. Connect the 5-wire harness to the 5 wires from the Zone Controller or Monitor Thermostat connector block using 5 wire nuts (field-supplied). Make sure the colors are consistent with the proper colored terminals on the connector block.
3. Wire the 24 VAC power to the red and black leads of the 24 VAC harness of the actuator using two field-supplied wire nuts. The green wire is not used. Cap the green wire with a wire nut.
4. To check actuator operation, refer to the Monitor Thermostat or Zone Controller Operation and Troubleshooting guide.

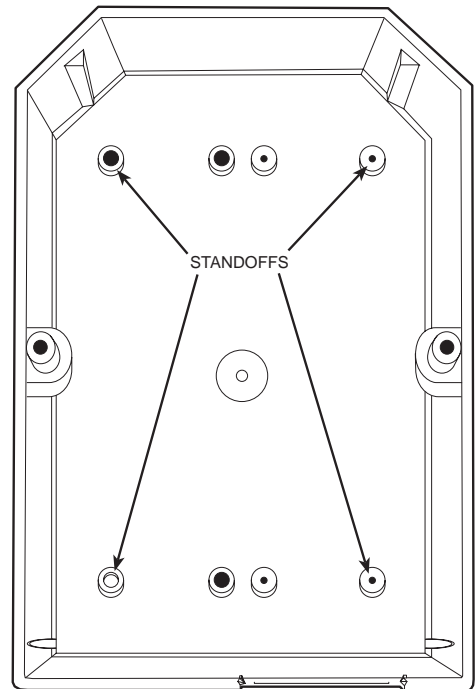
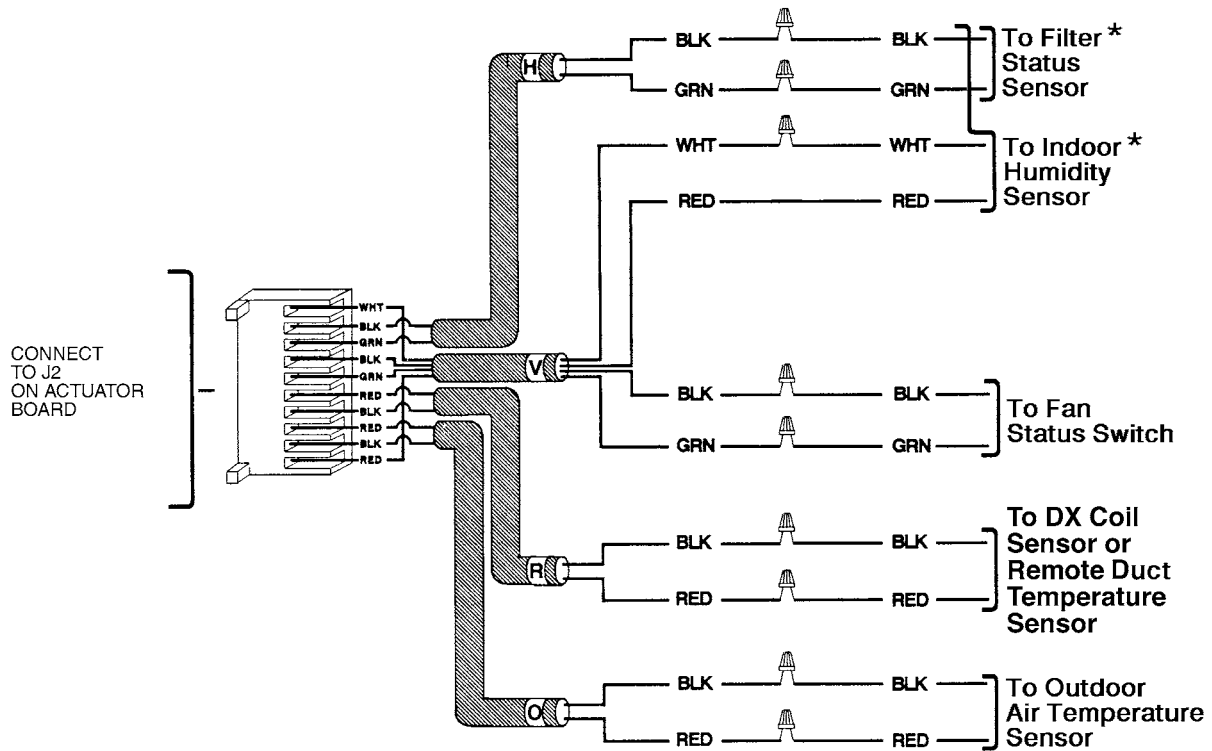

Fig. 4 — Actuator Cover (Inside)



LEGEND

DX — Direct Expansion

*Filter Status Switch and Humidity Sensor cannot function simultaneously. Only one sensor can be wired.

Fig. 5 — Damper Board Sensor Wiring with Multisensor Harness (Part Number 920222)

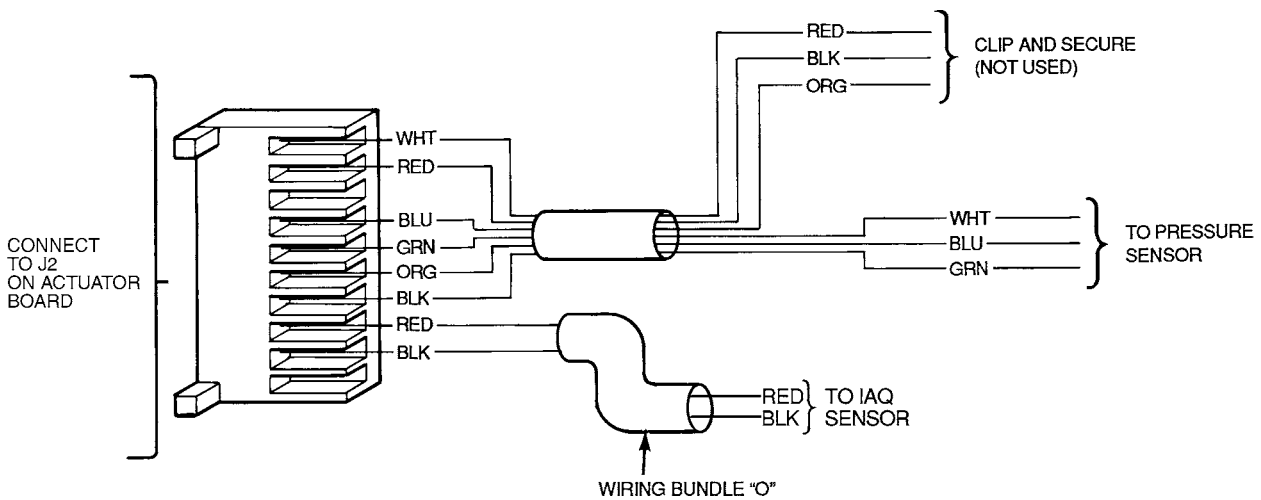

LEGEND

IAQ — Indoor Air Quality

Fig. 6 — Damper Board Sensor Wiring with Pressure Sensor Wiring Harness (Part Number 920286)

Connecting Multiple Actuators — The zone controller, bypass controller or monitor can be used to control one master damper and up to 3 slave dampers. See Fig. 7. The controller directly controls only the master damper. Slave dampers will receive and follow damper position commands sent to the master damper.

NOTE: The master and slave dampers must all be of the same type, i.e., 45 or 60 degrees of travel. The direct coupled actuators can connect with the non-direct coupled ZD/RD actuators

providing they are all same type. If connecting only direct coupled actuators, connect the green wire in addition to the yellow, blue and white wires. This gives feedback capability from each actuator, which will allow for an HF damper error should any damper fail. Do not connect the green wire if connecting non-direct coupled actuators or if connecting a combination of non-direct and direct coupled actuators.

NOTE: When connecting multiple actuators, only one actuator can have a duct sensor installed on it.

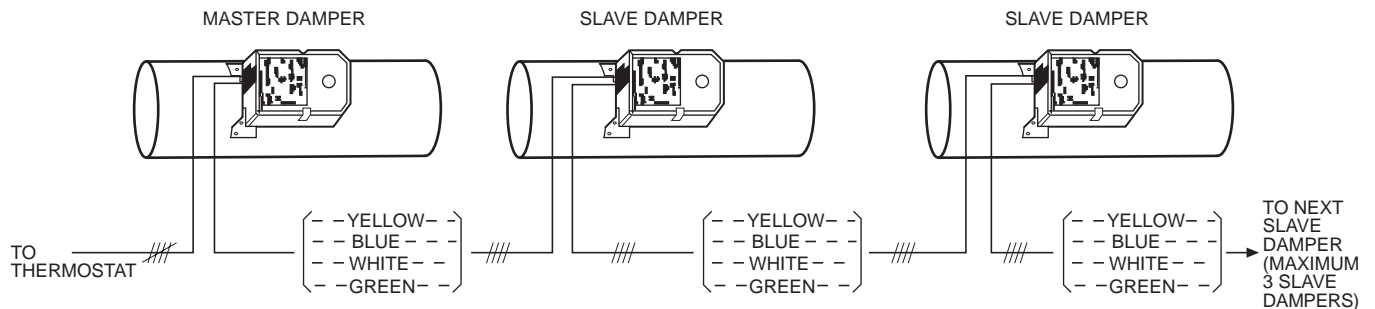

Fig. 7 — Connecting Multiple Actuators

