

50KCQ

Single Package Rooftop Heat Pump with Puron® (R-410A) Refrigerant Sizes: 04, 05, 06



Installation Instructions

NOTE: Read the entire instruction manual before starting the installation

TABLE OF CONTENTS

SAFETY CONSIDERATIONS	2	All Units	14
Rated Indoor Airflow (cfm)	3	Convenience Outlets	14
INSTALLATION	6	Factory-Option Thru-Base Connections	16
Step 1 - Plan for Unit Location	6	Units without Thru-Base Connections	16
Roof Mount	6	Field Control Wiring	16
Step 2 - Plan for Sequence of Unit Installation	6	Thermostat	16
Curb-Mount Installation	7	Unit without Thru-Base Connection Kit	17
Pad-Mount Installation	7	Heat Anticipator Settings	17
Frame-Mount Installation	7	Electric Heaters	17
Step 3 - Inspect Unit	7	Single Point Boxes & Supplementary Fuses	18
Step 4 - Provide Unit Support	7	Single Point Boxes without Fuses	18
Roof Curb Mount	7	Low-Voltage Control Connections	18
Slab Mount (Horizontal Units Only)	7	EconoMi\$er X (Factory-Installed Option)	19
Alternate Unit Support (In Lieu of Curb or Slab Mount)	7	PremierLink™ (Factory Option)	20
Step 5 - Field Fabricate Ductwork	9	Supply Air Temperature (SAT) Sensor	22
For Units with Accessory Electric Heaters	9	Outdoor Air Temperature (OAT) Sensor	22
Step 6 - Rig and Place Unit	9	EconoMi\$er2	22
Positioning on Curb	9	Field Connections	22
Step 7 - Convert to Horizontal and Connect Ductwork	10	Space Sensors	24
Step 8 - Install Outside Air Hood	11	Connect Thermostat	24
Economizer and Two Position Damper Hood Package Removal and Setup — Factory Option ..	11	Configure the Unit for Thermostat Mode	24
Economizer Hood and Two-Position Hood	11	Economizer Controls	25
Step 9 - Units with Hinged Panels Only	12	Indoor Air Quality (CO ₂ sensor)	25
Step 10 - Install External Condensate Trap and Line	12	Outdoor Air Quality Sensor	25
Step 11 - Make Electrical Connections	13	Smoke Detector/Fire Shutdown (FSD)	26
Field Power Supply	13	Filter Status Switch	26
Units with Factory-Installed Non-Fused Disconnect	13	Supply Fan Status Switch	26
Units without Factory-Installed Non-Fused Disconnect	14	Remote Occupied Switch	26
		Power Exhaust (output)	26
		CCN Communication Bus	27
		RTU Open Control System	28
		Supply Air Temperature (SAT) Sensor	30
		Outdoor Air Temperature (OAT) Sensor	30
		EconoMi\$er2	30
		Field Connections	31
		Space Temperature (SPT) Sensors	31

Indoor Air Quality (CO ₂) Sensor	31
Outdoor Air Quality Sensor	32
Smoke Detector/Fire Shutdown (FSD)	32
Connecting Discrete Inputs	32
Communication Wiring - Protocols	33
General	33
Local Access	34
RTU Open Troubleshooting	34
Outdoor Air Enthalpy Control	35
Differential Enthalpy Control	35
Return Air Enthalpy Sensor	36
Smoke Detectors	36
Step 12 - Adjust Factory-Installed Options	44
Step 13 - Install Accessories	44
UNIT START-UP CHECKLIST	47

SAFETY CONSIDERATIONS

Improper installation, adjustment, alteration, service, maintenance, or use can cause explosion, fire, electrical shock or other conditions which may cause personal injury or property damage. Consult a qualified installer, service agency, or your distributor or branch for information or assistance. The qualified installer or agency must use factory-authorized kits or accessories when modifying this product. Refer to the individual instructions packaged with the kits or accessories when installing.

Follow all safety codes. Wear safety glasses and work gloves. Use quenching cloths for brazing operations and have a fire extinguisher available. Read these instructions thoroughly and follow all warnings or cautions attached to the unit. Consult local building codes and appropriate national electrical codes (in USA, ANSI/NFPA 70, National Electrical Code (NEC); in Canada, CSA C22.1) for special requirements.

It is important to recognize safety information. This is the safety-alert symbol . When you see this symbol on the unit and in instructions or manuals, be alert to the potential for personal injury.

Understand the signal words DANGER, WARNING, CAUTION, and NOTE. These words are used with the safety-alert symbol. DANGER identifies the most serious hazards which **will** result in severe personal injury or death. WARNING signifies hazards which **could** result in personal injury or death. CAUTION is used to identify unsafe practices, which **may** result in minor personal injury or product and property damage. NOTE is used to highlight suggestions which **will** result in enhanced installation, reliability, or operation.

WARNING

ELECTRICAL SHOCK HAZARD

Failure to follow this warning could cause personal injury or death.

Before performing service or maintenance operations on unit, turn off main power switch to unit and install lock(s) and lockout tag(s). Ensure electrical service to rooftop unit agrees with voltage and amperage listed on the unit rating plate. Unit may have more than one power switch.

WARNING

UNIT OPERATION AND SAFETY HAZARD

Failure to follow this warning could cause personal injury, death and/or equipment damage.

Puron® (R-410A) refrigerant systems operate at higher pressures than standard R-22 systems. Do not use R-22 service equipment or components on Puron refrigerant equipment.

WARNING

PERSONAL INJURY AND ENVIRONMENTAL HAZARD

Failure to follow this warning could cause personal injury or death.

Relieve pressure and recover all refrigerant before system repair or final unit disposal.

Wear safety glasses and gloves when handling refrigerants. Keep torches and other ignition sources away from refrigerants and oils.

CAUTION

CUT HAZARD

Failure to follow this caution may result in personal injury.

Sheet metal parts may have sharp edges or burrs. Use care and wear appropriate protective clothing, safety glasses and gloves when handling parts and servicing air conditioning equipment.

Rated Indoor Airflow (cfm)

This table lists the rated indoor airflow used for the AHRI efficiency rating for the units covered in this document.

Model Number	Full Load Airflow (cfm)
50KCQ*A04	1225
50KCQ*A05	1700
50KCQ*A06	1750

Position:	1	2	3	4	5	6	7	8	9	10	11	12	13	14	15	16	17	18
Example:	5	0	K	C	Q	A	0	6	A	0	A	6	-	0	B	2	A	0

Unit/Series/Model
50KCQ - Packaged Rooftop Heat Pump

Refrig. Systems Options
A = One Stage Cooling Models

Cooling Tons
04 - 3 ton
05 - 4 ton
06 - 5 ton

Sensor Options
A = None
B = RA Smoke Detector
C = SA Smoke Detector
D = RA + SA Smoke Detector
E = CO₂
F = RA Smoke Detector and CO₂
G = SA Smoke Detector and CO₂
H = RA + SA Smoke Detector and CO₂

Indoor Fan Options
0 = Electric Drive X13 Motor
1 = Standard Static Option – Belt Drive
2 = Medium Static Option – Belt Drive
3 = High Static Option – Belt Drive

Coil Options (Outdoor - Indoor - Hail Guard)
A = Al/Cu - Al/Cu
B = Precoat Al/Cu - Al/Cu
C = E-coat Al/Cu - Al/Cu
D = E-coat Al/Cu - E-coat Al/Cu
E = Cu/Cu - Al/Cu
F = Cu/Cu - Cu/Cu
M = Al/Cu -Al/Cu — Louvered Hail Guard
N = Precoat Al/Cu - Al/Cu — Louvered Hail Guard
P = E-coat Al/Cu - Al/Cu — Louvered Hail Guard
Q = E-coat Al/Cu - E-coat Al/Cu — Louvered Hail Guard
R = Cu/Cu - Al/Cu — Louvered Hail Guard
S = Cu/Cu - Cu/Cu — Louvered Hail Guard

Note: On single phase (-3 voltage code) models, the following are not available as a factory installed option:

- Coated Coils or Cu Fin Coils
- Louvered Hail Guards
- Economizer or 2 Position Damper
- Powered 115 Volt Convenience Outlet

Factory Assigned
0 = Standard
1 = LTL

Electrical Options
A = None
C = Non-Fused Disconnect
D = Thru-The-Base Connections
F = Non-Fused Disconnect and Thru-The-Base Connections

Service Options
0 = None
1 = Unpowered Convenience Outlet
2 = Powered Convenience Outlet
3 = Hinged Panels
4 = Hinged Panels and Unpowered Convenience Outlet
5 = Hinged Panels and Powered Convenience Outlet

Intake / Exhaust Options
A = None
B = Temperature Economizer w/ Barometric Relief
F = Enthalpy Economizer w/ Barometric Relief
K = 2-Position Damper
U = Temperature Ultra Low Leak Economizer w/ Barometric Relief
W = Enthalpy Ultra Low Leak Economizer w/ Barometric Relief

Base Unit Controls
0 = Electro-mechanical Controls can be used with W7212 EconoMi\$er IV (Non-Fault Detection and Diagnostic)
1 = PremierLink Controller
2 = RTU Open Multi-Protocol Controller
6 = Electro-mechanical with W7220 Economizer controller Controls. Can be used with W7220 EconoMi\$er X (with Fault Detection and Diagnostic)

Design Revision
- = Factory Design Revision

Voltage
1 = 575/3/60
3 = 208-230/1/60
5 = 208-230/3/60
6 = 460/3/60

50KCQ

Fig. 1 - 50KCQ 04-06 Model Number Nomenclature (Example)

C14261

 UNITED TECHNOLOGIES SPRACUSE, NY 13221
 P. O. BOX 4808
 THIS DOCUMENT IS THE PROPERTY OF CARRIER CORPORATION AND IS DELIVERED UPON THE EXPRESS CONDITION THAT THE USER SHALL NOT REPRODUCE, COPIY, OR TRANSMIT THIS DOCUMENT IN ANY MANNER WITHOUT CARRIER CORPORATION'S WRITTEN CONSENT.

SUBMISSION OF THESE DRAWINGS OR DOCUMENTS DOES NOT CONSTITUTE AN ACCEPTANCE OF CONTRACT.

UNIT	STD. UNIT WEIGHT (L.A)		CORNER WEIGHT (C)		CORNER WEIGHT (D)		C. G.		HEIGHT		
	LBS.	KG.	LBS.	KG.	LBS.	KG.	X	Y	Z		
50KCO 04	495	224	130	59	118	53	130	59	35.378 [898]	23.378 [594]	18.378 [467]
50KCO 05	580	263	161	73	147	66	130	59	35.172 [902]	21.718 [555]	20.172 [521]
50KCO 06	610	276	165	75	152	69	141	64	35.374 [908]	22.112 [571]	20.374 [527]

* STANDARD UNIT WEIGHT IS WITHOUT ELECTRIC HEAT AND WITHOUT PACKAGING.
 FOR OTHER OPTIONS AND ACCESSORIES, REFER TO THE PRODUCT DATA CATALOG.

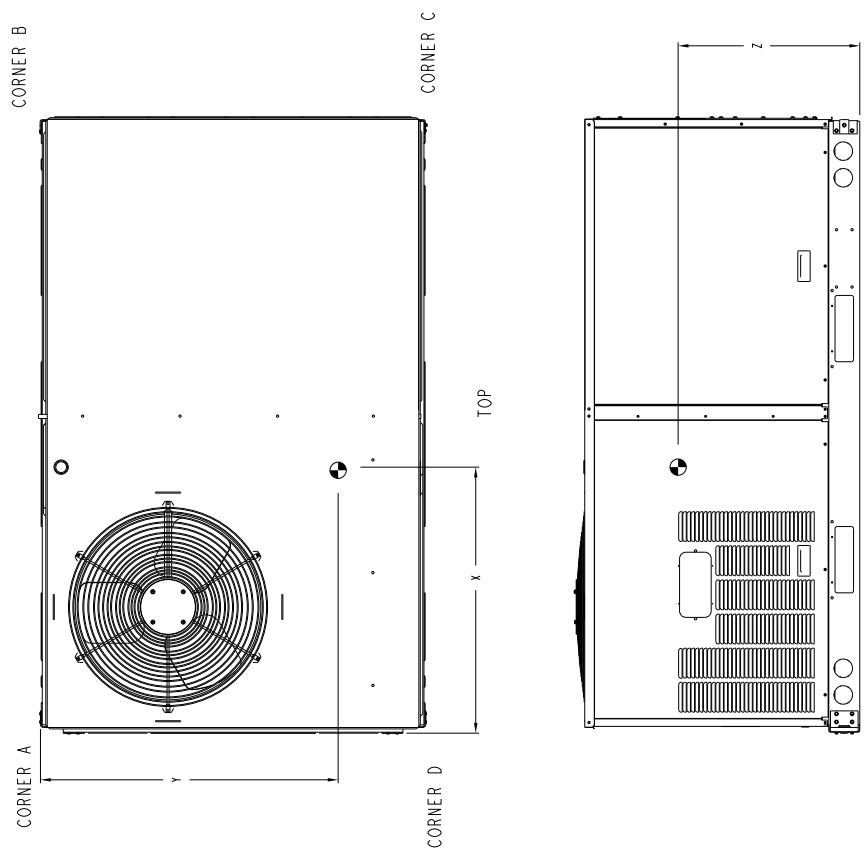

FRONT

SHEET 2 OF 2	DATE 08-14-14	SUPERCEDES -	50KCO 04-06 SINGLE-ZONE ELECTRIC HEAT PUMP	48KCO00283	REV -
-----------------	------------------	-----------------	---	------------	----------

Fig. 2 - Unit Dimensional Drawing (cont.)

50KCO

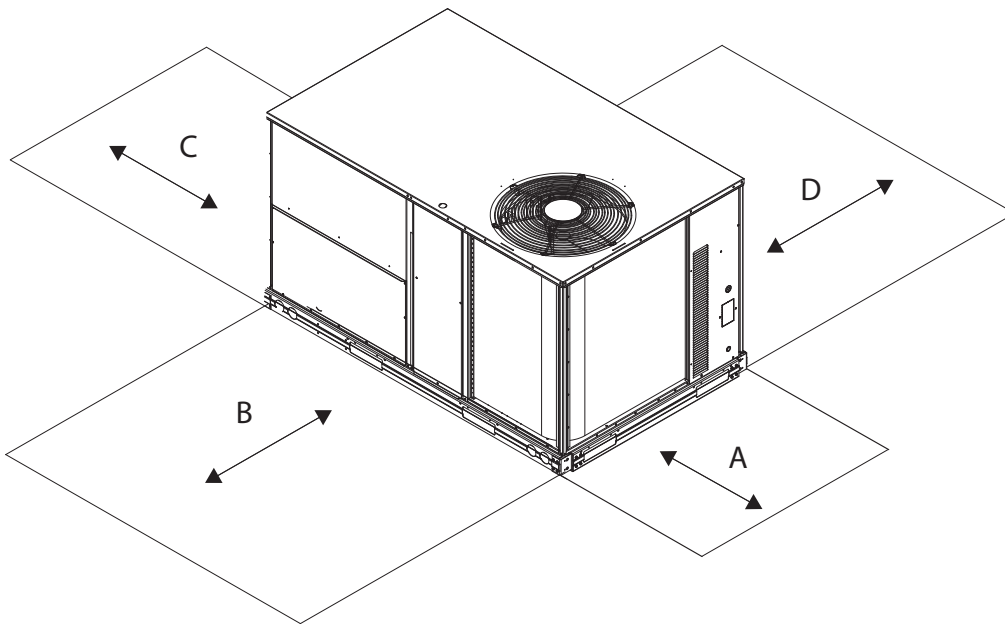

C08337

LOCATION	DIMENSION	CONDITION
A	48-in (1219 mm) 18-in (457 mm) 18-in (457 mm) 12-in (305 mm)	Unit disconnect is mounted on panel No disconnect, convenience outlet option Recommended service clearance Minimum clearance
B	42-in (1067 mm) 36-in (914 mm) Special	Surface behind servicer is grounded (e.g., metal, masonry wall) Surface behind servicer is electrically non-conductive (e.g., wood, fiberglass) Check sources of flue products within 10-ft of unit fresh air intake hood
C	36-in (914 mm) 18-in (457 mm)	Side condensate drain is used Minimum clearance
D	42-in (1067 mm) 36-in (914 mm) Special	Surface behind servicer is grounded (e.g., metal, masonry wall, another unit) Surface behind servicer is electrically non-conductive (e.g., wood, fiberglass) Check for adjacent units or building fresh air intakes within 10-ft (3 m) of this unit's flue outlet

NOTE: Unit not designed to have overhead obstruction. Contact Application Engineering for guidance on any application planning overhead obstruction or for vertical clearances.

Fig. 3 - Service Clearance Dimensional Drawing

INSTALLATION

Jobsite Survey

Complete the following checks before installation.

1. Consult local building codes and the NEC (National Electrical Code) (ANSI/NFPA 70) for special installation requirements.
2. Determine unit location (from project plans) or select unit location.
3. Check for possible overhead obstructions which may interfere with unit lifting or rigging.

Step 1 — Plan for Unit Location

Select a location for the unit and its support system (curb or other) that provides for minimum clearances required for safety (including clearance to combustible surfaces), unit performance and service access below, around and above unit as specified in unit drawings. See Fig. 3.

NOTE: Consider also the effect of adjacent units.

Unit may be installed directly on wood flooring or on Class A, B, or C roof-covering material when roof curb is used.

Do not install unit in an indoor location. Do not locate air inlets near exhaust vents or other sources of contaminated air.

Although unit is weatherproof, avoid locations that permit water from higher level runoff and overhangs to fall onto unit.

Select a unit mounting system that provides adequate height to allow for removal and disposal of frost and ice that will form during the heating-defrost mode as well as allow installation of condensate trap per requirements. Refer to Step 9 — Install External Condensate Trap and Line — for required trap dimensions.

Roof Mount —

Check building codes for weight distribution requirements. Unit operating weight is shown in Table 1.

Step 2 — Plan for Sequence of Unit Installation

The support method used for this unit will dictate different sequences for the steps of unit installation. For example, on curb-mounted units, some accessories must be installed on the unit before the unit is placed on the curb. Review the following for recommended sequences for installation steps.

Table 1 – Operating Weights

50KCQ	UNITS LB (KG)	UNITS LB (KG)	UNITS LB (KG)
	A04	A05	A06
Base Unit	495 (224)	580 (263)	610 (276)
Economizer			
Vertical	50 (23)	50 (23)	50 (23)
Horizontal	80 (36)	80 (36)	80 (36)
Cu Fins	25 (11)	43 (20)	56 (25)
Powered Outlet	35 (16)	35 (16)	35 (16)
Curb			
14-in/356 mm	115 (52)	115 (52)	115 (52)
24-in/610 mm	197 (89)	197 (89)	197 (89)

Curb-mounted Installation —

- Install curb
- Install field-fabricated ductwork inside curb
- Install accessory thru-base service connection package (affects curb and unit) (refer to accessory installation instructions for details)
- Prepare bottom condensate drain connection to suit planned condensate line routing (refer to Step 9 for details)
- Rig and place unit
- Install outdoor air hood
- Install condensate line trap and piping
- Make electrical connections
- Install other accessories

Pad-mounted Installation —

- Prepare pad and unit supports
- Check and tighten the bottom condensate drain connection plug
- Rig and place unit
- Convert unit to side duct connection arrangement
- Install field-fabricated ductwork at unit duct openings
- Install outdoor air hood
- Install condensate line trap and piping
- Make electrical connections
- Install other accessories

Frame-mounted installation —

Frame-mounted applications generally follow the sequence for a curb installation. Adapt as required to suit specific installation plan.

Step 3 — Inspect unit

Inspect unit for transportation damage. File any claim with transportation agency.

Confirm before installation of unit that voltage, amperage and circuit protection requirements listed on unit data plate agree with power supply provided.

Step 4 — Provide Unit Support

Roof Curb Mount —

Accessory roof curb details and dimensions are shown in Fig. 5. Assemble and install accessory roof curb in accordance with instructions shipped with the curb.

Curb should be level. This is necessary for unit drain to function properly. Unit leveling tolerances are shown in Fig. 4. Refer to Accessory Roof Curb Installation Instructions for additional information as required.

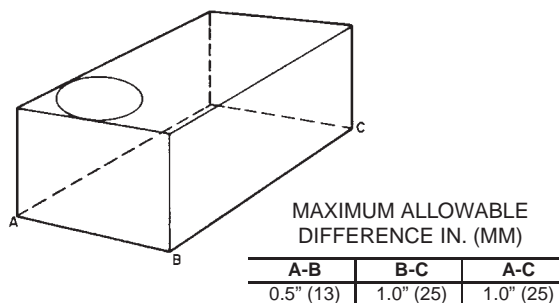

Fig. 4 - Unit Leveling Tolerances

C06110

Install insulation, cant strips, roofing felt, and counter flashing as shown. *Ductwork must be attached to curb and not to the unit. The accessory thru-the-base power package must be installed before the unit is set on the roof curb.*

If electric and control wiring is to be routed through the basepan, attach the accessory thru-the-base service connections to the basepan in accordance with the accessory installation instructions.

NOTE: The gasketing of the unit to the roof curb is critical for a watertight seal. Install gasket supplied with the roof curb as shown in Fig. 5. Improperly applied gasket can also result in air leaks and poor unit performance.

Slab Mount (Horizontal Units Only) —

Provide a level concrete slab that extends a minimum of 6 in. (150 mm) beyond unit cabinet. Install a gravel apron in front of condenser coil air inlet to prevent grass and foliage from obstructing airflow.

NOTE: Horizontal units may be installed on a roof curb if required.

Alternate Unit Support (In Lieu of Curb or Slab Mount) —

A non-combustible sleeper rail can be used in the unit curb support area. If sleeper rails cannot be used, support the long sides of the unit with a minimum of 3 equally spaced 4-in. x 4-in. (102 mm x 102 mm) pads on each side.

50KCQ

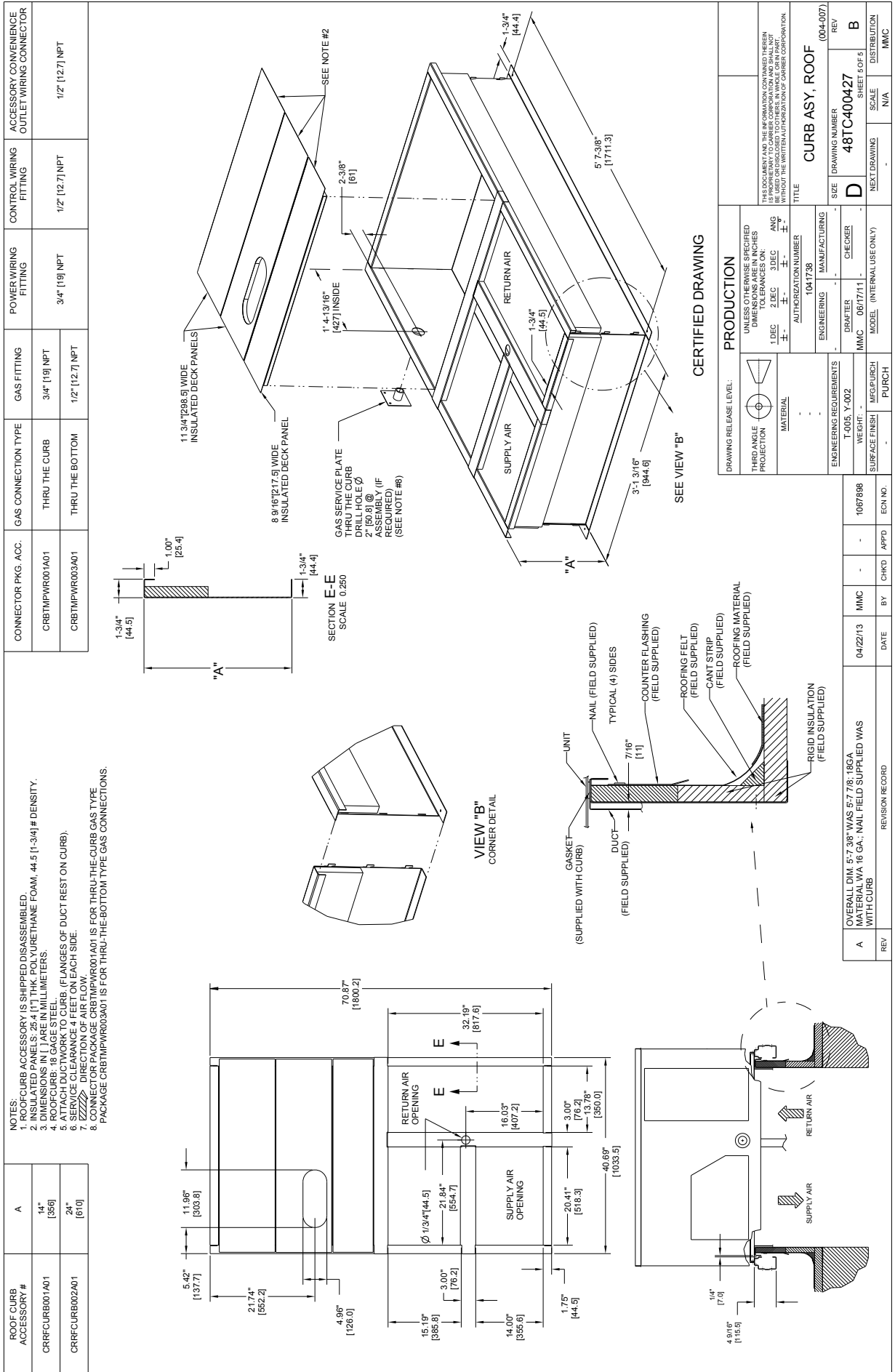

Fig. 5 - Roof Curb Details

Step 5 — Field Fabricate Ductwork

Cabinet return-air static pressure (a negative condition) shall not exceed 0.35 in. wg (87 Pa) with economizer or 0.45 in. wg (112 Pa) without economizer.

For vertical ducted applications, secure all ducts to roof curb and building structure. *Do not connect ductwork to unit.*

Fabricate supply ductwork so that the cross sectional dimensions are equal to or greater than the unit supply duct opening dimensions for the first 18 in. (458 mm) of duct length from the unit basepan.

Insulate and weatherproof all external ductwork, joints, and roof openings with counter flashing and mastic in accordance with applicable codes.

Ducts passing through unconditioned spaces must be insulated and covered with a vapor barrier.

If a plenum return is used on a vertical unit, the return should be ducted through the roof deck to comply with applicable fire codes.

⚠ CAUTION

PROPERTY DAMAGE HAZARD

Failure to follow this caution may result in damage to roofing materials.

Membrane roofs can be cut by sharp sheet metal edges. Be careful when placing any sheet metal parts on such roof.

For Units with Accessory Electric Heaters —

All installations require a minimum clearance to combustible surfaces of 1-in (25 mm) from duct for first 12-in (305 mm) away from unit.

Outlet grilles must not lie directly below unit discharge.

NOTE: A 90-degree elbow must be provided in the ductwork to comply with UL (Underwriters Laboratories) code for use with electric heat.

⚠ WARNING

PERSONAL INJURY HAZARD

Failure to follow this warning could cause personal injury.

For vertical supply and return units, tools or parts could drop into ductwork and cause an injury. Install a 90-degree turn in the return ductwork between the unit and the conditioned space. If a 90-degree elbow cannot be installed, then a grille of sufficient strength and density should be installed to prevent objects from falling into the conditioned space. Due to electric heater, supply duct will require 90-degree elbow.

Step 6 — Rig and Place Unit

Keep unit upright and do not drop. Spreader bars are not required if top crating is left on unit. Rollers may be used to move unit across a roof. Level by using unit frame as a reference. See Table 1 and Fig. 6 for additional information.

Lifting holes are provided in base rails as shown in Fig. 6. Refer to rigging instructions on unit.

Before setting the unit onto the curb, recheck gasketing on curb.

→ Rigging materials under unit (cardboard or wood to prevent base pan damage) must be removed PRIOR to placing the unit on the roof curb.

When using the standard side drain connection, ensure the red plug in the alternate bottom connection is tight. Do this before setting the unit in place. The red drain pan plug can be tightened with a 1/2-in. square socket drive extension. For further details see “Step 10 - Install External Condensate Trap and Line” on page 12.

⚠ CAUTION

UNIT DAMAGE HAZARD

Failure to follow this caution may result in equipment damage.

All panels must be in place when rigging. Unit is not designed for handling by fork truck.

If using top crate as spreader bar, once unit is set, carefully lower wooden crate off building roof top to ground. Ensure that no people or obstructions are below prior to lowering the crate.

Positioning on Curb —

Position unit on roof curb so that the following clearances are maintained: 1/4 in. (6.4 mm) clearance between the roof curb and the base rail inside the front and rear, 0.0 in. clearance between the roof curb and the base rail inside on the duct end of the unit. This will result in the distance between the roof curb and the base rail inside on the condenser end of the unit being approximately 1/4 in. (6.4 mm).

Although unit is weatherproof, guard against water from higher level runoff and overhangs.

After unit is in position, remove rigging skids and shipping materials.

⚠ CAUTION - NOTICE TO RIGGERS:
⚠ AVERTISSEMENT - REMARQUE À L'ATTENTION DES MONTEURS

ALL PANELS MUST BE IN PLACE WHEN RIGGING.
 TOUS LES CAPOTS DOIVENT ÊTRE EN PLACE AVANT LE LEVAGE

- Hook rigging shackles through holes in base rail, as shown in detail "A".
- Use wooden top skid, when rigging, to prevent rigging straps from damaging unit.
- Spreader bars required to lift and transport the unit.
- Accrocher les manilles des élingues de levages dans les trous situés dans le rail de base comme indiqué au détail « A ».
- Utiliser des cales en bois lors du levage pour éviter que les élingues n'endommagent le haut de l'appareil.
- Barres d'écartement requises pour soulever et transporter l'unité.

PLACE ALL SEAL STRIP IN PLACE BEFORE PLACING UNIT ON ROOF CURB.
 INSTALLER TOUTES LES BANDES D'ISOLATION EN PLACE AVANT DE PLACER L'APPAREIL SUR LE REBORD DE TOIT.

DUCT END PASSAGES CONDUITES

DETAIL A
DÉTAIL « A »

	MAX WEIGHT		A		B		C	
	LB	KG	IN	MM	IN	MM	IN	MM
48KC04	795	361	74.5	1890	39.0	990	33.5	850
48KC05	890	405	74.5	1890	39.0	990	33.5	850
48KC06	1020	464	74.5	1890	39.0	990	41.5	1055
50KC04	760	345	74.5	1890	38.0	965	33.5	850
50KC05	850	386	74.5	1890	38.0	965	33.5	850
50KC06	985	448	74.5	1890	38.0	965	41.5	1055
50KCQ04	755	343	74.5	1890	38.5	980	33.5	850
50KCQ05	870	395	74.5	1890	37.5	955	41.5	1055
50KCQ06	925	420	74.5	1890	37.5	955	41.5	1055

48KC000261 -

Fig. 6 - Rigging Label

C14240

Step 7 — Convert to Horizontal and Connect Ductwork (when required)

Unit is shipped in the vertical duct configuration. Unit without factory-installed economizer or return air smoke detector option may be field-converted to horizontal ducted configuration. To convert to horizontal configuration, remove screws from side duct opening covers and remove covers. Using the same screws, install covers on vertical duct openings with the insulation-side down. Seals around duct openings must be tight. See Fig. 7.

Field-supplied flanges should be attached to horizontal duct openings and all ductwork should be secured to the flanges. Insulate and weatherproof all external ductwork, joints, and roof or building openings with counter flashing and mastic in accordance with applicable codes.

Do not cover or obscure visibility to the unit's informative data plate when insulating horizontal ductwork.

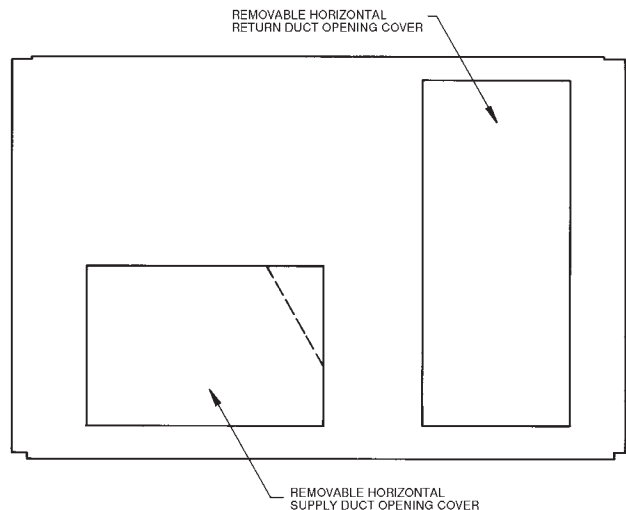

Fig. 7 - Horizontal Conversion Panels

C06108

Step 8 — Install Outside Air Hood

Economizer and Two Position Damper Hood Package Removal and Setup - Factory Option

NOTE: Economizer and Two Position Damper are not available as factory installed options for size 04-06 single phase (-3 voltage code) models.

1. The hood is shipped in knock-down form and must be field assembled. The indoor coil access panel is used as the hood top while the hood sides, divider and filter are packaged together, attached to a metal support tray using plastic stretch wrap, and shipped in the return air compartment behind the indoor coil access panel. The hood assembly's metal tray is attached to the basepan and also attached to the damper using two plastic tie-wraps.
2. To gain access to the hood, remove the filter access panel. (See Fig. 8.)

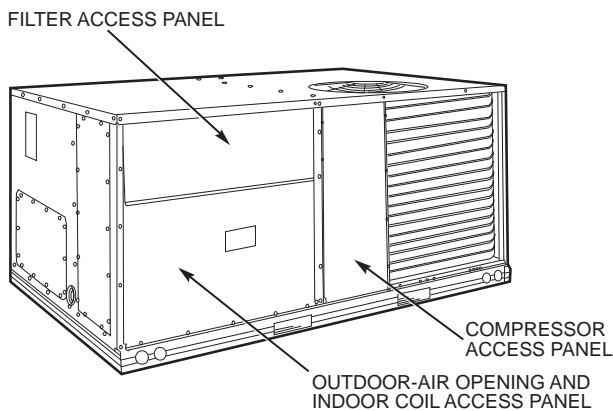

Fig. 8 - Typical Access Panel Locations

C06023

3. Locate the (2) screws holding the metal tray to the basepan and remove. Locate and cut the (2) plastic tie-wraps securing the assembly to the damper. (See Fig. 9) Be careful to not damage any wiring or cut tie-wraps securing any wiring.

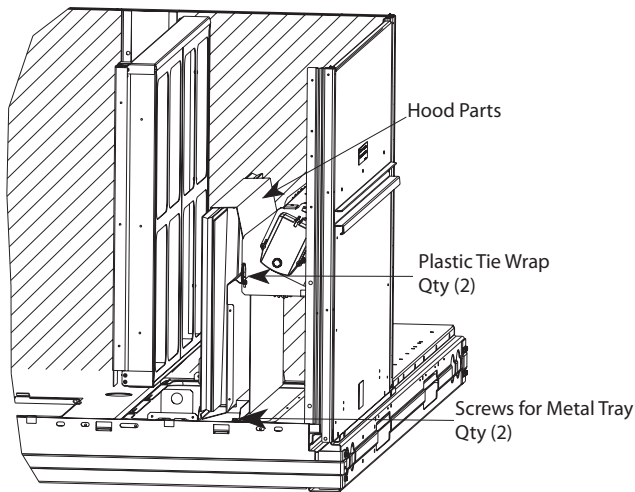

Fig. 9 - Economizer and Two-Position Damper Hood Parts Location

C08639

4. Carefully lift the hood assembly (with metal tray) through the filter access opening and assemble per the steps outlined in *Economizer Hood and Two-Position Hood*, below.

Economizer Hood and Two-Position Hood —

NOTE: If the power exhaust accessory is to be installed on the unit, the hood shipped with the unit will not be used and must be discarded. Save the aluminum filter for use in the power exhaust hood assembly.

1. The indoor coil access panel will be used as the top of the hood. Remove the screws along the sides and bottom of the indoor coil access panel. See Fig. 10.

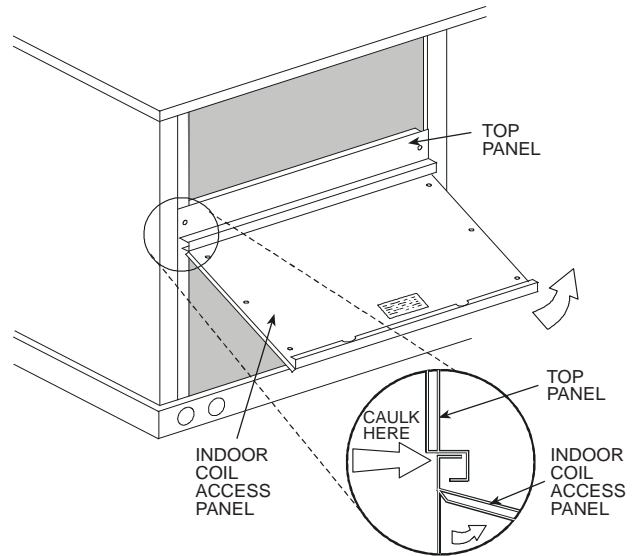

Fig. 10 - Indoor Coil Access Panel Relocation

C06025

2. Swing out indoor coil access panel and insert the hood sides under the panel (hood top). Use the screws provided to attach the hood sides to the hood top. Use screws provided to attach the hood sides to the unit. See Fig. 11.

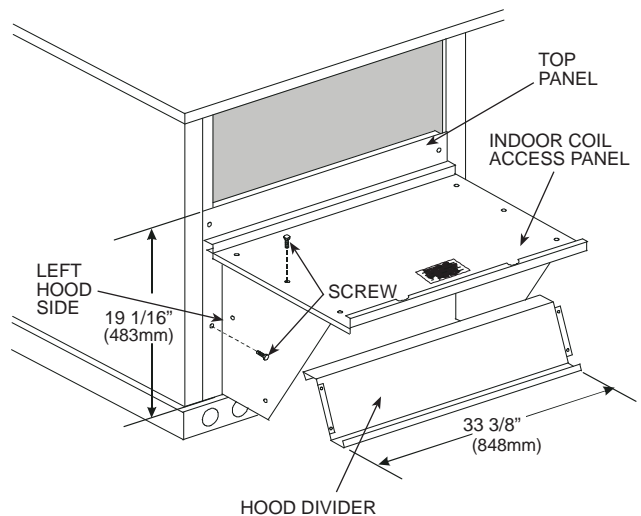

Fig. 11 - Economizer Hood Construction

C06026

3. Remove the shipping tape holding the economizer barometric relief damper in place (economizer only).

4. Insert the hood divider between the hood sides. See Fig. 11 and Fig. 12. Secure hood divider with 2 screws on each hood side. The hood divider is also used as the bottom filter rack for the aluminum filter.
5. Open the filter clips which are located underneath the hood top. Insert the aluminum filter into the bottom filter rack (hood divider). Push the filter into position past the open filter clips. Close the filter clips to lock the filter into place. See Fig. 12.
6. Caulk the ends of the joint between the unit top panel and the hood top.
7. Replace the filter access panel.

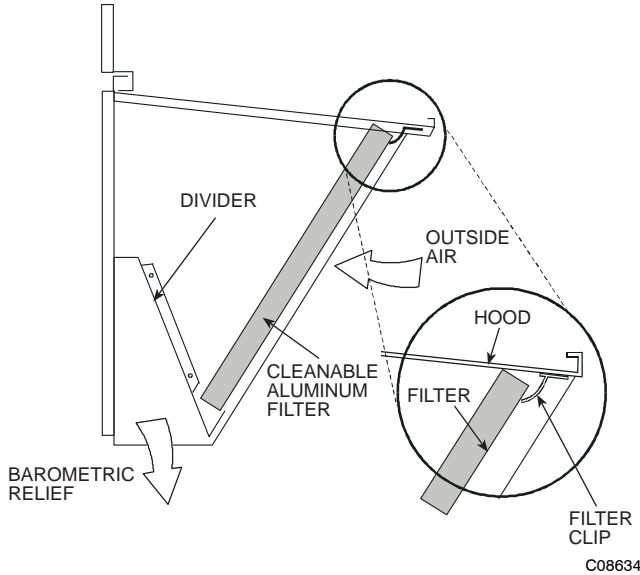

Fig. 12 - Economizer Filter Installation

Step 9 — Units with Hinged Panels Only

Relocate latch shipped inside the compressor compartment behind the hinged compressor door to location shown in Fig. 13 after unit installation.

If the unit does not have hinged panels, skip this step and continue at step 10.

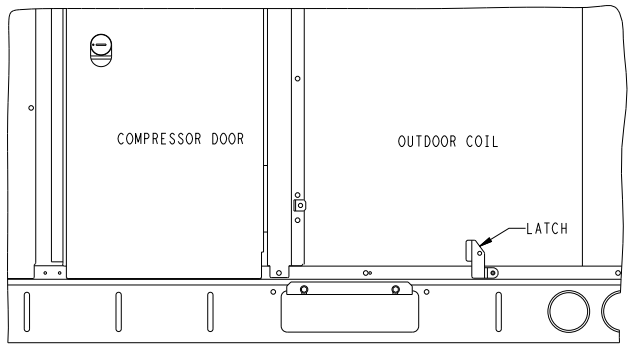

Fig. 13 - Compressor Door Latch Location

Step 10 — Install External Condensate Trap and Line

The unit has one 3/4-in. condensate drain connection on the end of the condensate pan and an alternate connection on the bottom. See Fig. 14. Unit airflow configuration does not determine which drain connection to use. Either drain connection can be used with vertical or horizontal applications.

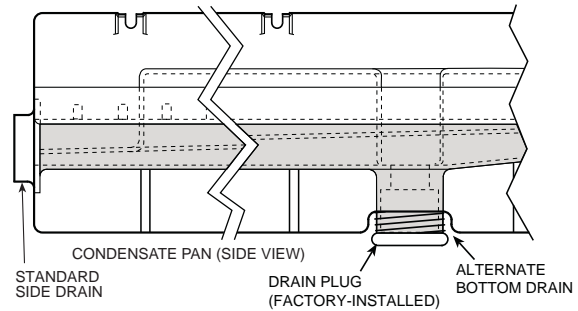
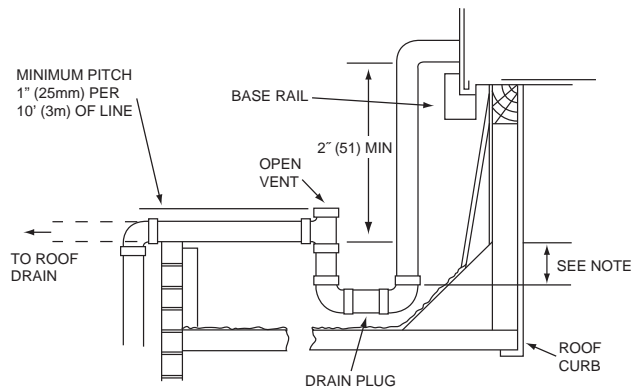

Fig. 14 - Condensate Drain Pan (Side View)

To use the alternate bottom drain connection, remove the red drain plug from the bottom connection (use a 1/2-in. square socket drive extension) and install it in the side drain connection.

The piping for the condensate drain and external trap can be completed after the unit is in place. See Fig. 15.



NOTE: Trap should be deep enough to offset maximum unit static difference. A 4" (102) trap is recommended

Fig. 15 - Condensate Drain Piping Details

All units must have an external trap for condensate drainage. Install a trap at least 4-in. (102 mm) deep and protect against freeze-up. If drain line is installed downstream from the external trap, pitch the line away from the unit at 1-in. per 10 ft (25 mm in 3 m) of run. Do not use a pipe size smaller than the unit connection (3/4-in.).

Step 11 — Make Electrical Connections

⚠️ WARNING

ELECTRICAL SHOCK HAZARD

Failure to follow this warning could result in personal injury or death.

Unit cabinet must have an uninterrupted, unbroken electrical ground to minimize the possibility of personal injury if an electrical fault should occur. This ground may consist of electrical wire connected to unit ground lug in control compartment, or conduit approved for electrical ground when installed in accordance with NEC; ANSI/NFPA 70, latest edition (in Canada, Canadian Electrical Code CSA [Canadian Standards Association] C22.1), and local electrical codes.

NOTE: Field-supplied wiring shall conform with the limitations of minimum 63°F (33°C) rise.

Field Power Supply —

If equipped with optional Powered Convenience Outlet: The power source leads to the convenience outlet's transformer primary are not factory connected. Installer must connect these leads according to required operation of the convenience outlet. If an always-energized convenience outlet operation is desired, connect the source leads to the line side of the unit-mounted disconnect. (Check with local codes to ensure this method is acceptable in your area.) If a de-energize via unit disconnect switch operation of the convenience outlet is desired, connect the source leads to the load side of the unit disconnect. On a unit without a unit-mounted disconnect, connect the source leads to compressor contactor C and indoor fan contactor IFC pressure lugs with unit field power leads.

Refer to Fig. 22 for power transformer connections and the discussion on connecting the convenience outlet on page 13.

Field power wires are connected to the unit at line-side pressure lugs on compressor contactor C and indoor fan contactor IFC (see wiring diagram label for control box component arrangement) or at factory-installed option non-fused disconnect switch. Max wire size is #2 AWG (copper only). See Fig. 16 and unit label diagram for field power wiring connections.

NOTE: TEST LEADS - Unit may be equipped with short leads (pigtailed) on the field line connection points on contactor C or optional disconnect switch. These leads are for factory run-test purposes only; remove and discard before connecting field power wires to unit connection points. Make field power connections directly to line connection pressure lugs only.

Units Without Non-Fused Disconnect Option

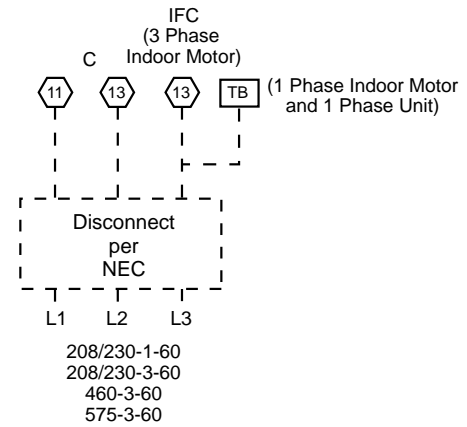

Units With Non-Fused Disconnect Option

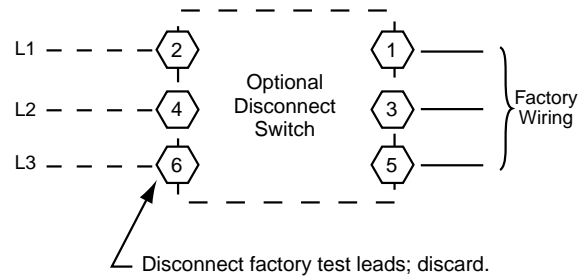

C14264

Fig. 16 - Power Wiring Connections

⚠️ WARNING

FIRE HAZARD

Failure to follow this warning could result in intermittent operation or performance satisfaction.

Do not connect aluminum wire between disconnect switch and 50KCCQ unit. Use only copper wire. (See Fig. 17.)

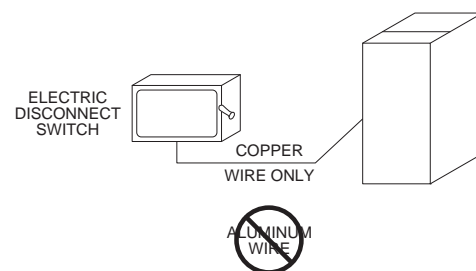

A93033

Fig. 17 - Disconnect Switch and Unit

Units with Factory-Installed Non-Fused Disconnect —

The factory-installed option non-fused disconnect (NFD) switch is located in a weatherproof enclosure located under the main control box. The manual switch handle and shaft are shipped in the disconnect enclosure. Assemble the shaft and handle to the switch at this point. Discard the factory test leads (see Fig. 16).

Connect field power supply conductors to LINE side terminals when the switch enclosure cover is removed to attach the handle.

50KCCQ

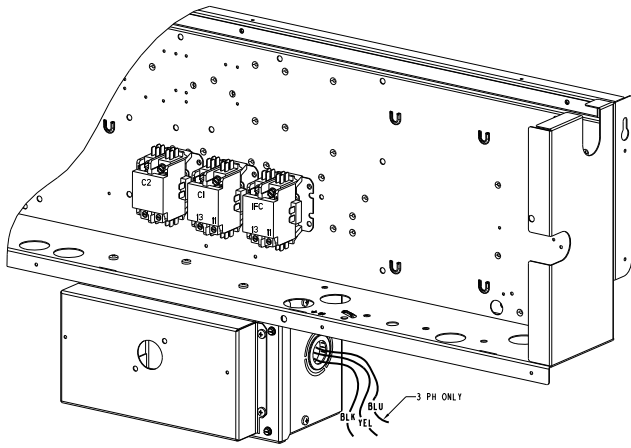

C12284

Fig. 18 - Location of Non-Fused Disconnect Enclosure

To field install the NFD shaft and handle:

1. Remove the unit front pane (see Fig. 2).
2. Remove (3) hex screws on the NFD enclosure - (2) on the face of the cover and (1) on the left side cover.
3. Remove the front cover of the NFD enclosure.
4. Make sure the NFD shipped from the factory is at OFF position (the arrow on the black handle knob is at OFF).
5. Insert the shaft with the cross pin on the top of the shaft in the horizontal position.
6. Measure from the tip of the shaft to the top surface of the black pointer; the measurement should be 3.75 - 3.88 in. (95 - 99 mm).
7. Tighten the locking screw to secure the shaft to the NFD.
8. Turn the handle to the OFF position with red arrow pointing at OFF.
9. Install the handle on to the painted cover horizontally with the red arrow pointing to the left.
10. Secure the handle to the painted cover with (2) screws and lock washers supplied.
11. Engaging the shaft into the handle socket, re-install (3) hex screws on the NFD enclosure.
12. Re-install the unit front panel.

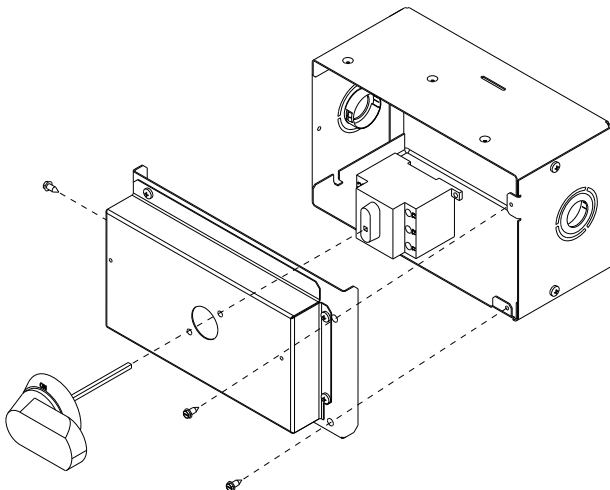

C12279

Fig. 19 - Handle and Shaft Assembly for NFD

Units Without Factory-Installed Non-Fused Disconnect —

When installing units, provide a disconnect switch per NEC (National Electrical Code) of adequate size. Disconnect sizing data is provided on the unit informative plate. Locate on unit cabinet or within sight of the unit per national or local codes. Do not cover unit informative plate if mounting the disconnect on the unit cabinet.

All Units —

All field wiring must comply with NEC and all local codes. Size wire based on MCA (Minimum Circuit Amps) on the unit informative plate. See Fig. 16 and the unit label diagram for power wiring connections to the unit power terminal blocks and equipment ground. Maximum wire size is #2 ga AWG (copper only) per pole on contactors.

Provide a ground-fault and short-circuit over-current protection device (fuse or breaker) per NEC Article 440 (or local codes). Refer to unit informative data plate for MOCP (Maximum Over-current Protection) device size.

All field wiring must comply with the NEC and local requirements.

All units except 208/230-v units are factory wired for the voltage shown on the nameplate. *If the 208/230-v unit is to be connected to a 208-v power supply, the control transformer must be rewired by moving the black wire with the 1/4-in. female spade connector from the 230-v connection and moving it to the 200-v 1/4-in. male terminal on the primary side of the transformer.* Refer to unit label diagram for additional information. Field power wires will be connected line-side pressure lugs on the power terminal block or at factory-installed option non-fused disconnect.

NOTE: Check all factory and field electrical connections for tightness.

Convenience Outlets —

⚠ WARNING

ELECTRICAL OPERATION HAZARD

Failure to follow this warning could result in personal injury or death.

Units with convenience outlet circuits may use multiple disconnects. Check convenience outlet for power status before opening unit for service. Locate its disconnect switch, if appropriate, and open it. Lock-out and tag-out this switch, if necessary.

Two types of convenience outlets are offered on 50KCQ models: Non-powered and unit-powered. Both types provide a 125-volt GFCI (ground-fault circuit-interrupter) duplex receptacle rated at 15-A behind a hinged waterproof access cover, located on the end panel of the unit. See Fig. 20.

NOTE: Unit powered convenience outlets are not available as factory installed options for size 04-06 single phase (-3 voltage code) models.

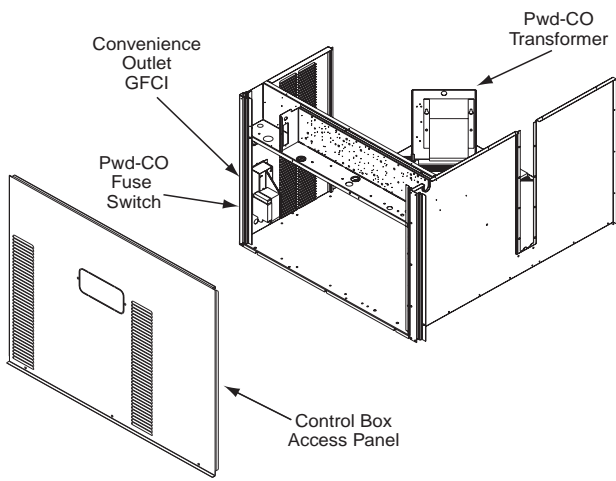

C08128

Fig. 20 - Convenience Outlet Location

Installing Weatherproof Cover: A weatherproof while-in-use cover for the factory-installed convenience outlets is now required by UL standards. This cover cannot be factory-mounted due its depth; it must be installed at unit installation. For shipment, the convenience outlet is covered with a blank cover plate.

The weatherproof cover kit is shipped in the unit's control box. The kit includes the hinged cover, a backing plate and gasket.

DISCONNECT ALL POWER TO UNIT AND CONVENIENCE OUTLET. LOCK-OUT AND TAG-OUT ALL POWER.

Remove the blank cover plate at the convenience outlet; discard the blank cover.

Loosen the two screws at the GFCI duplex outlet, until approximately 1/2-in (13 mm) under screw heads are exposed. Press the gasket over the screw heads. Slip the backing plate over the screw heads at the keyhole slots and align with the gasket; tighten the two screws until snug (do not over-tighten).

Mount the weatherproof cover to the backing plate as shown in Fig. 21. Remove two slot fillers in the bottom of the cover to permit service tool cords to exit the cover. Check for full closing and latching.

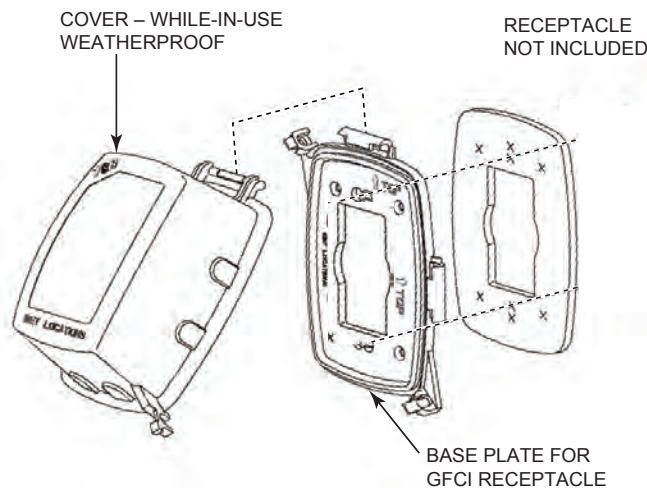

C09022

Fig. 21 - Weatherproof Cover Installation

Non-powered type: This type requires the field installation of a general-purpose 125-volt 15-A circuit powered from a source elsewhere in the building. Observe national and local codes when selecting wire size, fuse or breaker requirements and disconnect switch size and location. Route 125-v power supply conductors into the bottom of the utility box containing the duplex receptacle.

Unit-powered type: A unit-mounted transformer is factory-installed to stepdown the main power supply voltage to the unit to 115-v at the duplex receptacle. This option also includes a manual switch with fuse, located in a utility box and mounted on a bracket behind the convenience outlet; access is through the unit's control box access panel. See Fig. 20.

The primary leads to the convenience outlet transformer are not factory-connected. Selection of primary power source is a customer-option. If local codes permit, the transformer primary leads can be connected at the line-side terminals on the unit-mounted non-fused disconnect switch; this will provide service power to the unit when the unit disconnect switch is open. Other connection methods will result in the convenience outlet circuit being de-energized when the unit disconnect switch is open. See Fig. 22.

50KCC

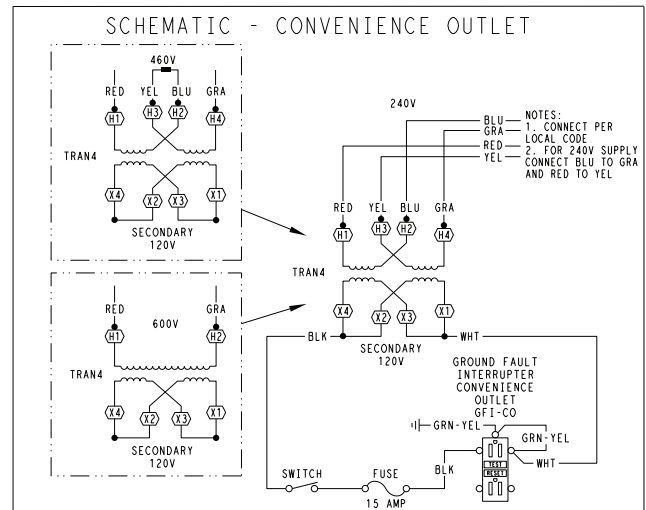

C08283

UNIT VOLTAGE	CONNECT AS	PRIMARY CONNECTIONS	TRANSFORMER TERMINALS
208, 230	240	L1: RED + YEL L2: BLU + GRA	H1 + H3 H2 + H4
460	480	L1: RED Splice BLU + YEL L2: GRA	H1 H2 + H3 H4
575	600	L1: RED L2: GRA	H1 H2

Fig. 22 - Powered Convenience Outlet Wiring

Using unit-mounted convenience outlets: Units with unit-mounted convenience outlet circuits will often require that two disconnects be opened to de-energize all power to the unit. Treat all units as electrically energized until the convenience outlet power is also checked and de-energization is confirmed. Observe National Electrical Code Article 210, Branch Circuits, for use of convenience outlets.

Fuse on power type: The factory fuse is a Bussman “Fusetron” T-15, non-renewable screw-in (Edison base) type plug fuse.

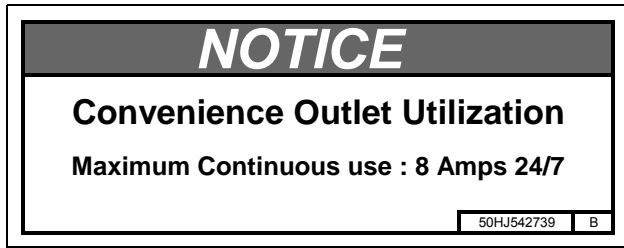

C13415

Fig. 23 - Convenience Outlet Utilization Notice Label

Duty Cycle: the unit-powered convenience outlet has a duty cycle limitation. The transformer is intended to provide power on an intermittent basis for service tools, lamps, etc; it is not intended to provide 15-amps loading for continuous duty loads (such as electric heaters for overnight use). Observe a 50% limit on circuit loading above 8-amps.

Convenience outlet usage rating:

Continuous usage: 8 amps maximum

Test the GFCI receptacle by pressing the TEST button on the face of the receptacle to trip and open the receptacle. Check for proper grounding wires and power line phasing if the GFCI receptacle does not trip as required. Press the RESET button to clear the tripped condition.

Factory-Option Thru-Base Connections —

This service connection kit consists of two 1/2-in electrical bulkhead connectors and a 3/4-in electrical bulkhead connector, all factory-installed in the embossed (raised) section of the unit basepan in the condenser section. The 3/4-in bulkhead connector enables the low-voltage control wires to pass through the basepan. The 1/2-in electrical bulkhead connector allows the high-voltage power wires to pass through the basepan. See Fig. 24.

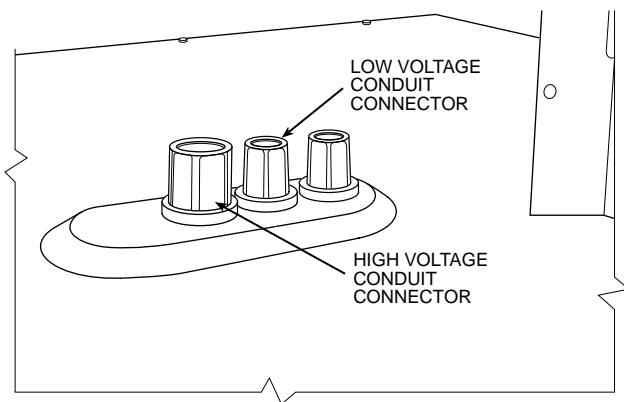

C13412

Fig. 24 - Thru-Base Connection Fittings

Check tightness of connector lock nuts before connecting electrical conduits.

Field-supplied and field-installed liquid tight conduit connectors and conduit may be attached to the connectors

on the basepan. Pull correctly rated high voltage and low voltage through appropriate conduits. Connect the power conduit to the internal disconnect (if unit is so equipped) or to the external disconnect (through unit side panel). A hole must be field cut in the main control box bottom on the left side so the 24-v control connections can be made. Connect the control power conduit to the unit control box at this hole.

Units without Thru-Base Connections —

1. Install power wiring conduit through side panel openings. Install conduit between disconnect and control box.
2. Install power lines to terminal connections as shown in Fig. 16.

Voltage to compressor terminals during operation must be within voltage range indicated on unit nameplate. See Table 10. On 3-phase units, voltages between phases must be balanced within 2% and the current within 10%. Use the formula shown in the legend for Table 10, Note 2 to determine the percent of voltage imbalance. Operation on improper line voltage or excessive phase imbalance constitutes abuse and may cause damage to electrical components. Such operation would invalidate any applicable Carrier warranty.

Field Control Wiring —

The 50KCQ unit requires an external temperature control device. This device can be a thermostat (field-supplied) or a PremierLink controller (available as factory-installed option or as field-installed accessory, for use on a Carrier Comfort Network or as a stand alone control) or the RTU Open Controller for Building Management Systems using non-CCN protocols (RTU Open is available as a factory-installed option only).

Thermostat —

Select a Carrier-approved accessory thermostat. When electric heat is installed in the 50KCQ unit, the thermostat must be capable of energizing the G terminal (to energize the Indoor Fan Contactor) whenever there is a space call for heat (energizing the W1 terminal). The accessory thermostats listed on the unit price pages can provide this signal but they are not configured to enable this signal as shipped.

Install the accessory thermostat according to installation instructions included with the accessory.

Locate the thermostat accessory on a solid wall in the conditioned space to sense average temperature in accordance with the thermostat installation instructions.

If the thermostat contains a logic circuit requiring 24-v power, use a thermostat cable or equivalent single leads of different colors with minimum of seven leads. If the thermostat does not require a 24-v source (no “C” connection required), use a thermostat cable or equivalent with minimum of six leads. Check the thermostat installation instructions for additional features which might require additional conductors in the cable.

50KCQ

For wire runs up to 50 ft. (15 m), use no. 18 AWG (American Wire Gage) insulated wire [35°C (95°F) minimum]. For 50 to 75 ft. (15 to 23 m), use no. 16 AWG insulated wire [35°C (95°F) minimum]. For over 75 ft. (23 m), use no. 14 AWG insulated wire [35°C (95°F) minimum]. All wire sizes larger than no. 18 AWG cannot be directly connected to the thermostat and will require a junction box and splice at the thermostat.

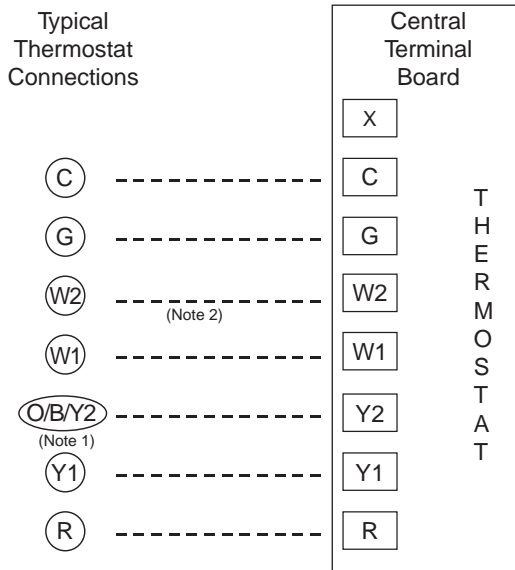

Note 1: Typical multi-function marking. Follow manufacturer's configuration instructions to select Y2. Do not configure for O output.

Note 2: W2 connection not required on units without electric heating.

--- Field Wiring

C09012

Fig. 25 - Low-Voltage Connections

Unit without Thru-Base Connection Kit —

Pass the thermostat control wires through the hole provided in the corner post; then feed the wires through the raceway built into the corner post to the control box. Pull the wires over to the terminal strip on the upper-left corner of the Controls Connection Board. See Fig. 26.

NOTE: If thru-the-bottom connections accessory is used, refer to the accessory installation instructions for information on routing power and control wiring.

Heat Anticipator Settings —

Set heat anticipator settings at 0.14 amp for the first stage and 0.14 amp for second-stage heating, when available.

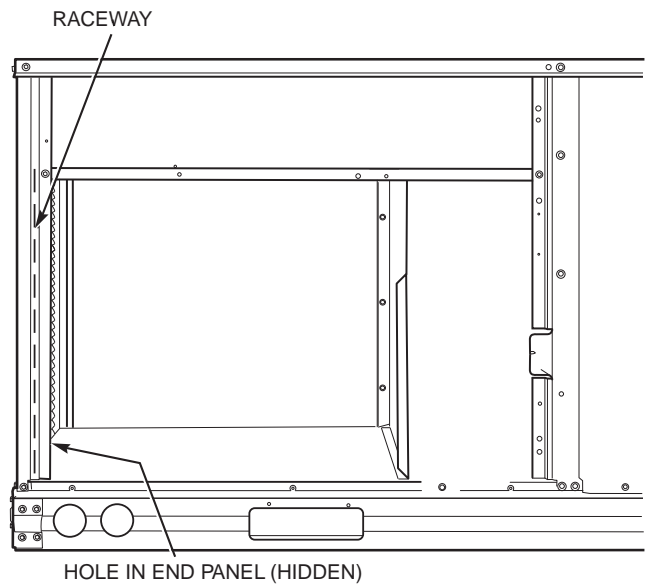

C08027

Fig. 26 - Field Control Wiring Raceway

Electric Heaters

50KCQ units may be equipped with field-installed accessory electric heaters. The heaters are modular in design, with heater frames holding open coil resistance wires strung through ceramic insulators, line-break limit switches and a control contactor. One or two heater modules may be used in a unit.

Heater modules are installed in the compartment below the indoor (supply) fan outlet. Access is through the indoor access panel. Heater modules slide into the compartment on tracks along the bottom of the heater opening. See Fig. 27, Fig. 28 and Fig. 29.

Not all available heater modules may be used in every unit. Use only those heater modules that are UL listed for use in a specific size unit. Refer to the label on the unit cabinet for the list of approved heaters.

Unit heaters are marked with Heater Model Numbers. But heaters are ordered as and shipped in cartons marked with a corresponding heater Sales Package part number. See Table 2 for correlation between heater Model Number and Sales Package part number.

NOTE: The value in position 9 of the part number differs between the sales package part number (value is 1) and a bare heater model number (value is 0).

Table 2 – Heater Model Number

Bare Heater Model Number	C	R	H	E	A	T	E	R	0	0	1	A	0	0
Heater Sales Package PNO Includes: Bare Heater Carton and packing materials Installation sheet	C	R	H	E	A	T	E	R	1	0	1	A	0	0

50KCQ

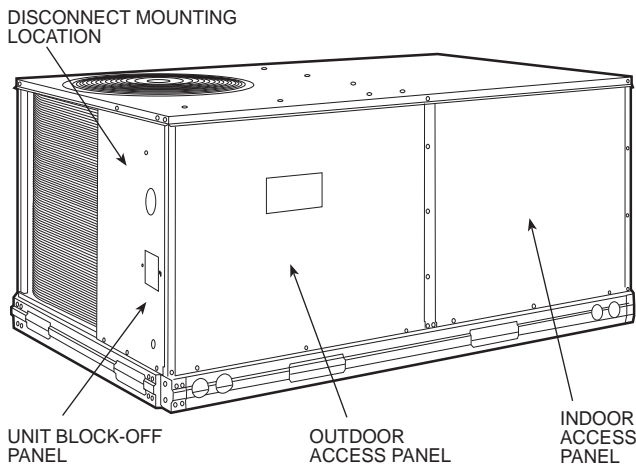

Fig. 27 - Typical Access Panel Location (3-5 Ton)

C08133

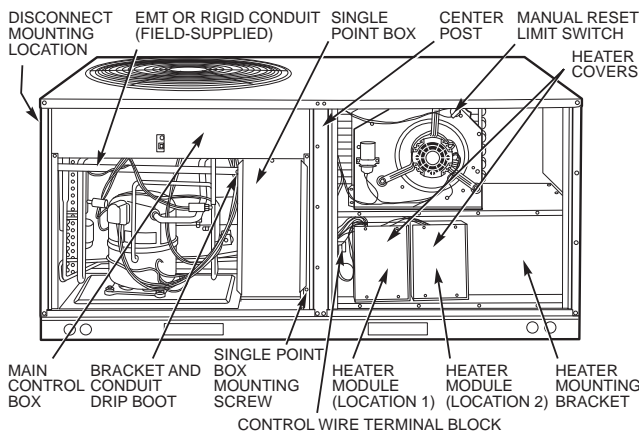

Fig. 28 - Typical Component Location

C08134

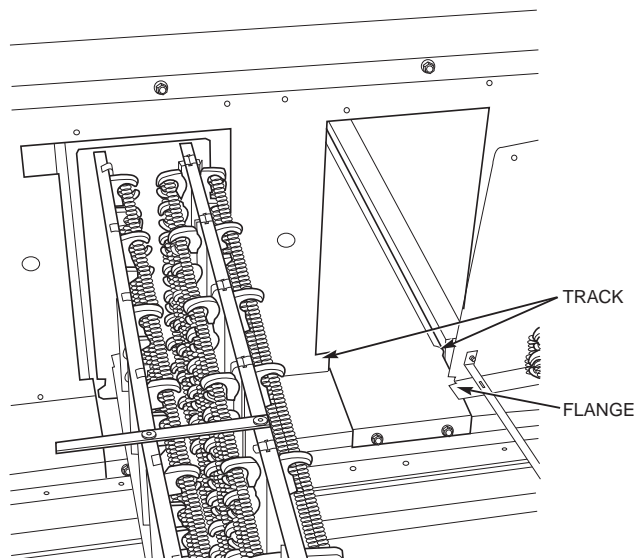

Fig. 29 - Typical Module Installation

C08135

Single Point Boxes and Supplementary Fuses —

When the unit MOCB device value exceeds 60-A, unit-mounted supplementary fuses are required for each heater circuit. These fuses are included in accessory Single Point Boxes, with power distribution and fuse blocks. The single point box will be installed directly under the unit control box, just to the left of the partition separating the indoor section (with electric heaters) from the outdoor section. The Single Point Box has a hinged access cover. See Fig. 30. The Single Point Box also includes a set of power taps and pigtails to complete the wiring between the Single Point Box and the unit's main control box terminals. Refer to the accessory heater and Single Point Box installation instructions for details on tap connections.

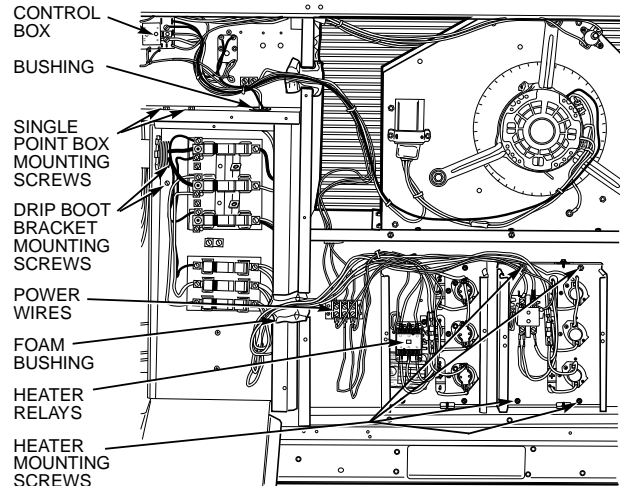

Fig. 30 - Typical Single Point Installation

C14253

All fuses on 50KCQ units are 60-A. (Note that all heaters are qualified for use with a 60-A fuse, regardless of actual heater ampacity, so only 60-A fuses are necessary.)

Single Point Boxes without Fuses —

Unit heater applications not requiring supplemental fuses require a special Single Point Box without any fuses. The accessory Single Point Boxes contain a set of power taps and pigtails to complete the wiring between the Single Point Box and the unit's main control box terminals. Refer to accessory heater and Single Point Box installation instructions for details on tap connections.

Low-Voltage Control Connections —

Run the low-voltage control leads from the heater module(s) - VIO and BRN (two of each if two modules are installed; identify for Module #1) - to the 4-pole terminal board TB4 located on the heater bulkhead to the left of Heater #1. Connect the VIO leads from Heater #1 and Heater #2 to terminal TB4-1. Connect the BRN leads to terminal TB4-3. See Fig. 31.

50KCQ

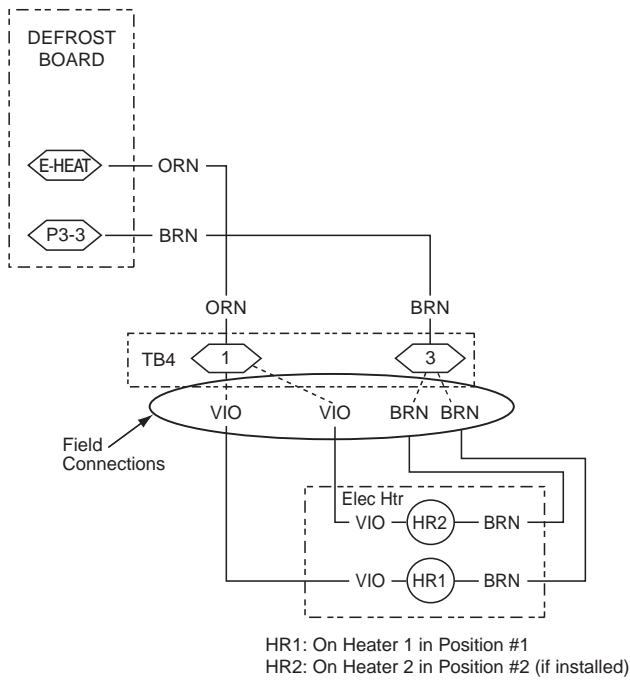

HR1: On Heater 1 in Position #1
 HR2: On Heater 2 in Position #2 (if installed)

C09013

Fig. 31 - Accessory Electric Heater Control Connections

EconoMiSer X (Factory-Installed Option)

For details on operating 50KCQ units equipped with the factory-installed EconoMiSer X option, refer to *Factory-Installed Economizers for TC/TCQ/HC/HCQ/LC/KC/KCQ Rooftop Units, 3 to 27.5 Nominal Tons. Economizer Supplement Related to California Title 24* (Catalog No. SUP-TI24-02SI, or later).

50KCQ

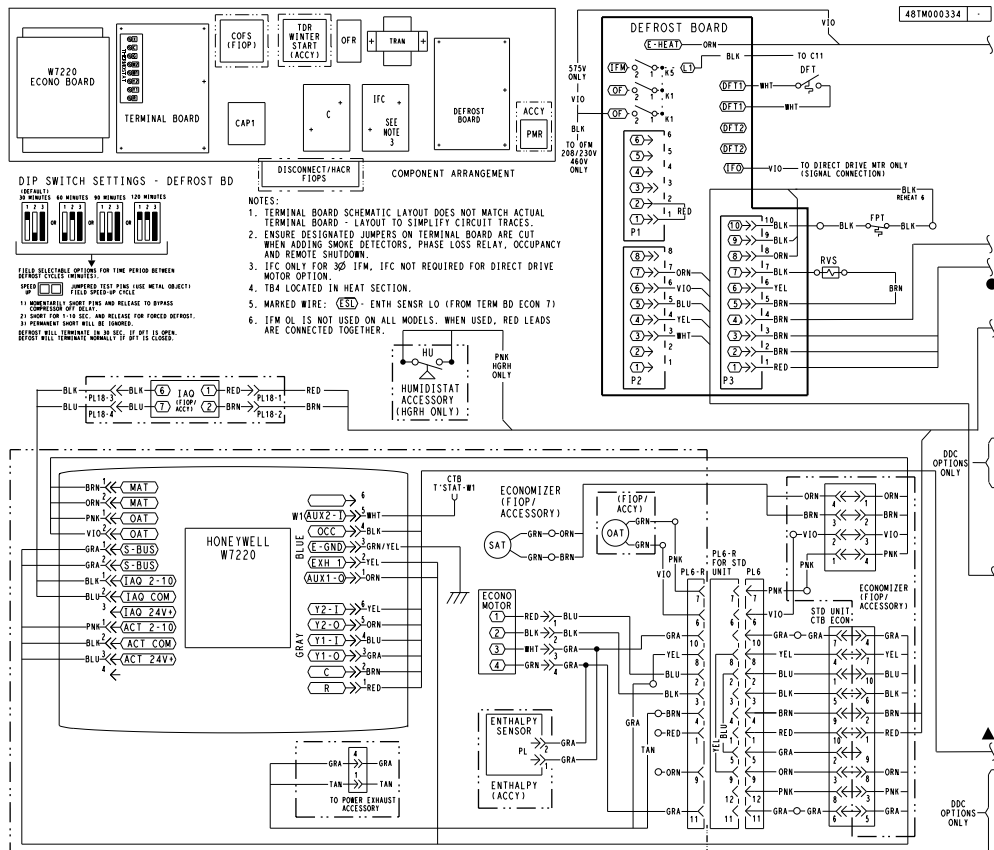

Fig. 32 - EconoMiSer X W7220 Controller Wiring Diagram

C14265

PremierLink™ (Factory-Option)

50KCQ

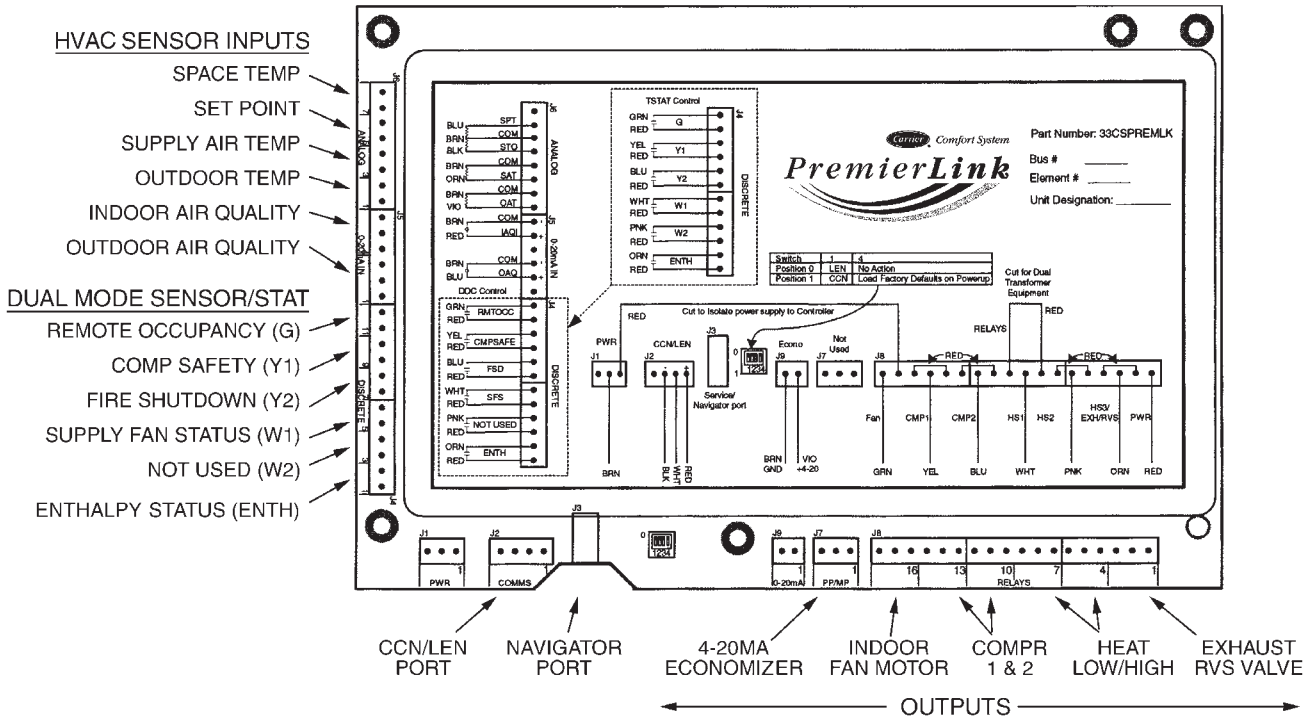

Fig. 33 - PremierLink Controller

C08199

The PremierLink controller (see Fig. 33) is compatible with Carrier Comfort Network® (CCN) devices. This control is designed to allow users the access and ability to change factory-defined settings, thus expanding the function of the standard unit control board. CCN service access tools include System Pilot (TM), Touch Pilot (TM) and Service Tool. (Standard tier display tools Navigator™ and Scrolling Marquee are not suitable for use with latest PremierLink controller (Version 2.x).)

The PremierLink control is factory-mounted in the 50KCQ unit's main control box to the left of the Central Terminal Board (CTB). Factory wiring is completed through harnesses connected to the CTB thermostat. Field connections are made at a 16-pole terminal block (TB1) located on the bottom shelf of the unit control box in front

of the PremierLink controller. The factory-installed PremierLink control includes the supply-air temperature (SAT) sensor. The outdoor air temperature (OAT) sensor is included in the FIOP/accessory EconomiSer™ 2 package.

The PremierLink controller requires the use of a Carrier electronic thermostat or a CCN connection for time broadcast to initiate its internal timeclock. This is necessary for broadcast of time of day functions (occupied/unoccupied).

NOTE: PremierLink controller is shipped in Sensor mode. To be used with a thermostat, the PremierLink controller must be configured to Thermostat mode. Refer to PremierLink Configuration instructions for Operating Mode.

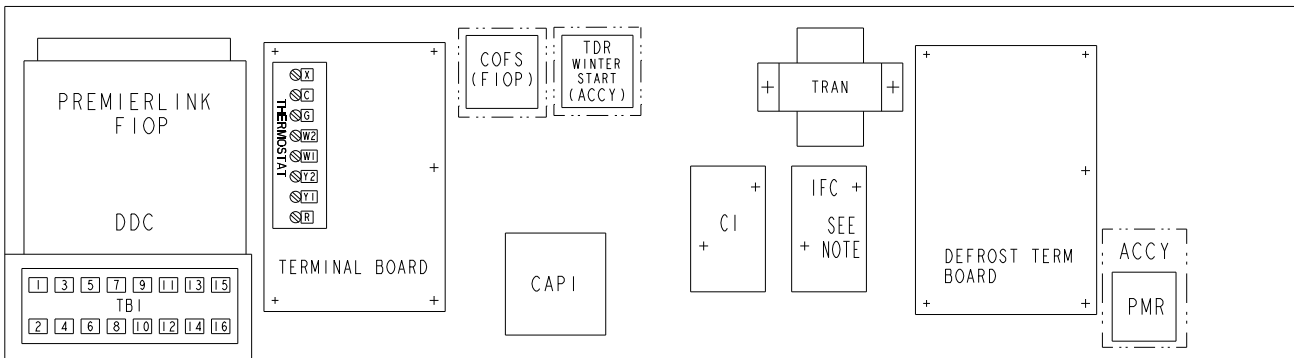

NOTE: IFC ONLY FOR 3Ø IFM, IFC NOT REQUIRED FOR DIRECT DRIVE MOTOR OPTION.

Fig. 34 - 50KCQ Control Box – PremierLink Location

C14266

Supply Air Temperature (SAT) Sensor —

On FIOP-equipped 50KCQ unit, the unit is supplied with a supply-air temperature (SAT) sensor (33ZCSENSAT). This sensor is a tubular probe type, approx 6-inches (152 mm) in length. It is a nominal 10-k ohm thermistor.

The SAT is factory-wired. The SAT probe is wire-tied to the supply-air opening (on the horizontal opening end) in its shipping position. Remove the sensor for installation. Re-position the sensor in the flange of the supply-air opening or in the supply air duct (as required by local codes). Drill or punch a 1/2-in. hole in the flange or duct. Use two field-supplied, self-drilling screws to secure the sensor probe in a horizontal orientation. See Fig. 36.

50KCQ

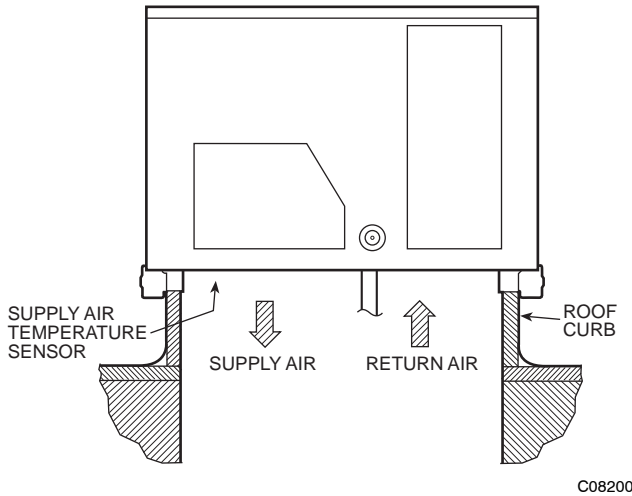

Fig. 36 - Typical Mounting Location for Supply Air Temperature (SAT) Sensor on Small Rooftop Units

NOTE: Refer to Form 33SC-68SI for complete PremierLink configuration, operating sequences and troubleshooting information. Have a copy of this manual available at unit start-up.

NOTE: The sensor must be mounted in the discharge airstream downstream of the cooling coil and any heating devices. Be sure the probe tip does not come in contact with any of the unit's heater surfaces.

Outdoor Air Temperature (OAT) Sensor —

The OAT is factory-mounted in the EconoMiSer2 (FIOP or accessory). It is a nominal 10k ohm thermistor attached to an eyelet mounting ring.

EconoMiSer2 —

The PremierLink control is used with EconoMiSer2 (option or accessory) for outdoor air management. The damper position is controlled directly by the PremierLink control; EconoMiSer2 has no internal logic device.

Outdoor air management functions can be enhanced with field-installation of these accessory control devices:

- Enthalpy control (outdoor air or differential sensors)
- Space CO₂ sensor
- Outdoor air CO₂ sensor

Refer to Table 3 for accessory part numbers.

Field Connections

Field connections for accessory sensor and input devices are made at the 16-pole terminal block (TB1) located on the control box bottom shelf in front of the PremierLink control (See Fig. 35). Some input devices also require a 24-vac signal source; connect at CTB terminal R at "THERMOSTAT" connection strip for this signal source. See connections figures on following pages for field connection locations (and for continued connections at the PremierLink board inputs).

Table 4 provides a summary of field connections for units equipped with Space Sensor. Table 5 provides a summary of field connections for units equipped with Space Thermostat.

Table 3 – PremierLink Sensor Usage

APPLICATION	OUTDOOR AIR TEMPERATURE SENSOR	RETURN AIR TEMPERATURE SENSOR	OUTDOOR AIR ENTHALPY SENSOR	RETURN AIR ENTHALPY SENSOR
Differential Dry Bulb Temperature with PremierLink (PremierLink requires 4–20 mA Actuator)	Included – CRTEMPN001A00	Required – 33ZCT55SPT or equivalent	–	–
Single Enthalpy with PremierLink (PremierLink requires 4–20mA Actuator)	Included – Not Used	–	Requires – 33CSENTHSW	–
Differential Enthalpy with PremierLink (PremierLink requires 4–20mA Actuator)	Included – Not Used	–	Requires – 33CSENTHSW or equivalent	Requires – 33CSENTSEN or equivalent

NOTES:

CO₂ Sensors (Optional):

- 33ZCSENC02 – Room sensor (adjustable). Aspirator box is required for duct mounting of the sensor.
- 33ZCASPC02 – Aspirator box used for duct-mounted CO₂ room sensor.
- 33ZCT55CO2 – Space temperature and CO₂ room sensor with override.
- 33ZCT56CO2 – Space temperature and CO₂ room sensor with override and setpoint.

Table 4 – Space Sensor Mode

TB1 TERMINAL	FIELD CONNECTION	INPUT SIGNAL
1	T55 – SEN/T56 – SEN	Analog (10k thermistor)
2	RMTOCC	Discrete, 24VAC
3	T55 – SEN/T56 – SEN	Analog (10k thermistor)
4	CMPSAFE	Discrete, 24VAC
5	T56 – SET	Analog (10k thermistor)
6	FSD	Discrete, 24VAC
7	LOOP – PWR	Analog, 24VDC
8	SPS	Discrete, 24VAC
9	IAQ – SEN	Analog, 4 – 20mA
10	FILTER	Discrete, 24VAC
11	IAQ – COM/OAQ – COM/RH – COM	Analog, 4 – 20mA
12	CCN + (RED)	Digital, , 5VDC
13	OAQ – SEN/RH – SEN	Analog, 4 – 20mA
14	CCN Gnd (WHT)	Digital, 5VDC
15	AUX OUT (Power Exhaust)	(Output) Discrete 24VAC
16	CCN – (BLK)	Digital, 5VDC

LEGEND:

- | | | | |
|---------|---|-----|--|
| T55 | – Space Temperature Sensor | FSD | – Fire Shutdown |
| T56 | – Space Temperature Sensor | IAQ | – Indoor Air Quality (CO ₂) |
| CCN | – Carrier Comfort Network (communication bus) | OAQ | – Outdoor Air Quality (CO ₂) |
| CMPSAFE | – Compressor Safety | RH | – Relative Humidity |
| FILTER | – Dirty Filter Switch | SFS | – Supply Fan Status |

Table 5 – Thermostat Mode

TB1 TERMINAL	FIELD CONNECTION	INPUT SIGNAL
1	RAT SEN	Analog (10k thermistor)
2	G	Discrete, 24VAC
3	RAT SEN	Analog (10k thermistor)
4	Y1	Discrete, 24VAC
5		
6	Y2	Discrete, 24VAC
7	LOOP – PWR	Analog, 24VDC
8	W1	Discrete, 24VAC
9	IAQ – SEN	Analog, 4 – 20mA
10	W2	Discrete, 24VAC
11	IAQ – COM/OAQ – COM/RH – COM	Analog, 4 – 20mA
12	CCN + (RED)	Digital, 5VDC
13	OAQ – SEN/RH – SEN	Analog, 4 – 20mA
14	CCN Gnd (WHT)	Digital, 5VDC
15	AUX OUT (Power Exhaust)	(Output) Discrete 24VAC
16	CCN – (BLK)	Digital, 5VDC

LEGEND:

- | | | | |
|-----|---|----|---------------------------|
| CCN | – Carrier Comfort Network (communication bus) | RH | – Relative Humidity |
| G | – Thermostat Fan | W1 | – Thermostat Heat Stage 1 |
| IAQ | – Indoor Air Quality (CO ₂) | W2 | – Thermostat Heat Stage 2 |
| OAQ | – Outdoor Air Quality (CO ₂) | Y1 | – Thermostat Cool Stage 1 |
| RAT | – Return Air Temperature | Y2 | – Thermostat Cool Stage 2 |

50KCC

Space Sensors —

The PremierLink controller is factory-shipped configured for Space Sensor Mode. A Carrier T-55 or T-56 space sensor must be used. T-55 space temperature sensor provides a signal of space temperature to the PremierLink control. T-56 provides same space temperature signal plus it allows for adjustment of space temperature setpoints from the face of the sensor by the occupants.

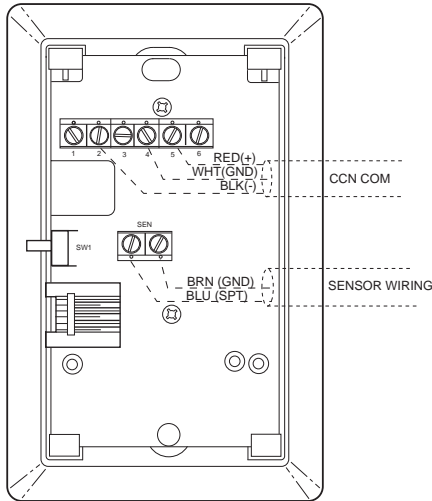

Fig. 37 - T-55 Space Temperature Sensor Wiring

Connect T-55: See Fig. 37 for typical T-55 internal connections. Connect the T-55 SEN terminals to TB1 terminals 1 and 3 (see Fig. 38).

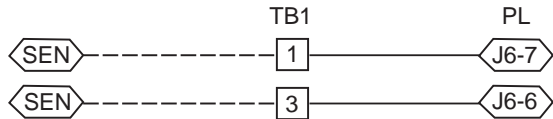

Fig. 38 - PremierLink T-55 Sensor

Connect T-56: See Fig. 39 for T-56 internal connections. Install a jumper between SEN and SET terminals as illustrated. Connect T-56 terminals to TB1 terminals 1, 3 and 5 (see Fig. 40).

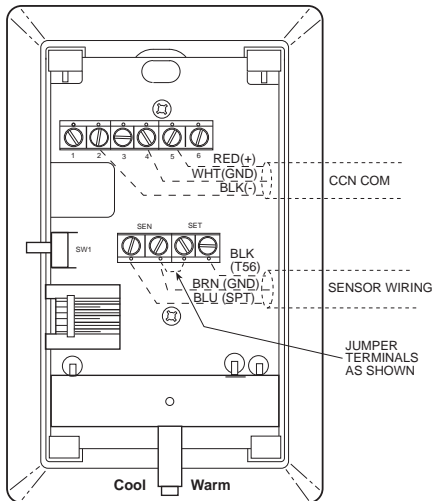

Fig. 39 - T-56 Internal Connections

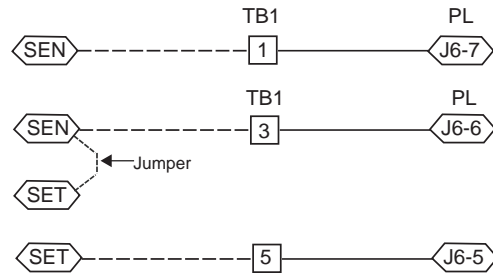

Fig. 40 - PremierLink T-56 Sensor

Connect Thermostat —

A 7-wire thermostat connection requires a 24-v power source and a common connection. Use the R and C terminals on the CTB's THERMOSTAT connection strip for these. Connect the thermostat's Y1, Y2, W1, W2 and G terminals to PremierLink TB1 as shown in Fig. 41.

If the 50KCQ unit is equipped with factory-installed smoke detector(s), disconnect the factory BLU lead at TB1-6 (Y2) before connecting the thermostat. Identify the BLU lead originating at CTB-DDC-1; disconnect at TB1-6 and tape off. Confirm that the second BLU lead at TB1-6 remains connected to PremierLink J4-8.

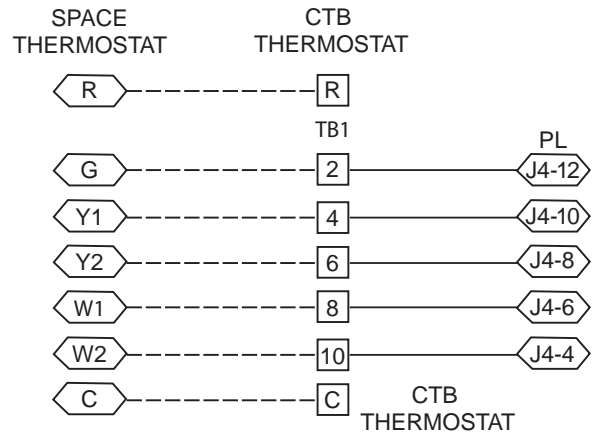

Fig. 41 - Space Thermostat Connections

If the 50KCQ unit has an economizer system and free-cooling operation is required, a sensor representing Return Air Temperature must also be connected (field-supplied and installed). This sensor may be a T-55 Space Sensor (see Fig. 37) installed in the space or in the return duct, or it may be sensor PNO 33ZCSENSAT, installed in the return duct. Connect this sensor to TB1-1 and TB1-3 per Fig. 38.

Configure the Unit for Thermostat Mode —

Connect to the CCN bus using a CCN service tool and navigate to PremierLink Configuration screen for Operating Mode. Default setting is Sensor Mode (value 1). Change the value to 0 to reconfigure the controller for Thermostat Mode.

When the PremierLink is configured for Thermostat Mode, these functions are not available: Fire Shutdown (FSD), Remote Occupied (RMTOCC), Compressor Safety (CMPSAFE), Supply Fan Status (SFS), and Filter Pressure Switch (FILTER).

Economizer Controls

Indoor Air Quality (CO₂) Sensor —

The indoor air quality sensor accessory monitors space carbon dioxide (CO₂) levels. This information is used to monitor IAQ levels. Several types of sensors are available, for wall mounting in the space or in return duct, with and without LCD display, and in combination with space temperature sensors. Sensors use infrared technology to measure the levels of CO₂ present in the space air.

The CO₂ sensors are all factory set for a range of 0 to 2000 ppm and a linear mA output of 4 to 20. Refer to the instructions supplied with the CO₂ sensor for electrical requirements and terminal locations. See Fig. 42 for typical CO₂ sensor wiring schematic.

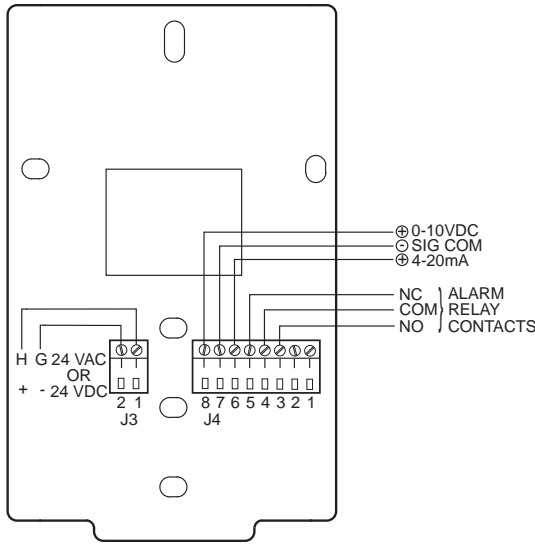

C08635

Fig. 42 - Indoor/Outdoor Air Quality (CO₂) Sensor (33ZCSENC02) - Typical Wiring Diagram

To accurately monitor the quality of the air in the conditioned air space, locate the sensor near a return-air grille (if present) so it senses the concentration of CO₂ leaving the space. The sensor should be mounted in a location to avoid direct breath contact.

Do not mount the IAQ sensor in drafty areas such as near supply ducts, open windows, fans, or over heat sources. Allow at least 3 ft (0.9 m) between the sensor and any corner. Avoid mounting the sensor where it is influenced by the supply air; the sensor gives inaccurate readings if the supply air is blown directly onto the sensor or if the supply air does not have a chance to mix with the room air before it is drawn into the return airstream.

Wiring the Indoor Air Quality Sensor: For each sensor, use two 2-conductor 18 AWG (American Wire Gauge) twisted-pair cables (unshielded) to connect the separate isolated 24 vac power source to the sensor and to connect the sensor to the control board terminals.

To connect the sensor to the control, identify the positive (4 to 20 mA) and ground (SIG COM) terminals on the sensor. See Fig. 42. Connect the 4-20 mA terminal to terminal TB1-9 and connect the SIG COM terminal to terminal TB1-11. See Fig. 43.

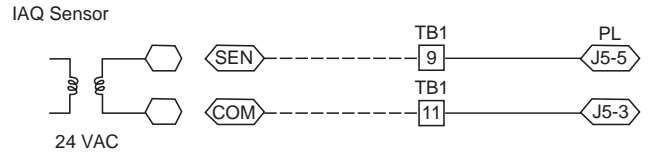

C08636

Fig. 43 - Indoor CO₂ Sensor (33ZCSENC02) Connections

Refer to Form 33SC-68SI, PremierLink Installation, Start-up, and Configuration Instructions, for detailed configuration information

Outdoor Air Quality Sensor

(PNO 33ZCSENC02 plus weatherproof enclosure) —

The outdoor air CO₂ sensor is designed to monitor carbon dioxide (CO₂) levels in the outside ventilation air and interface with the ventilation damper in an HVAC system. The OAQ sensor is packaged with an outdoor cover. See Fig. 44. The outdoor air CO₂ sensor must be located in the economizer outside air hood.

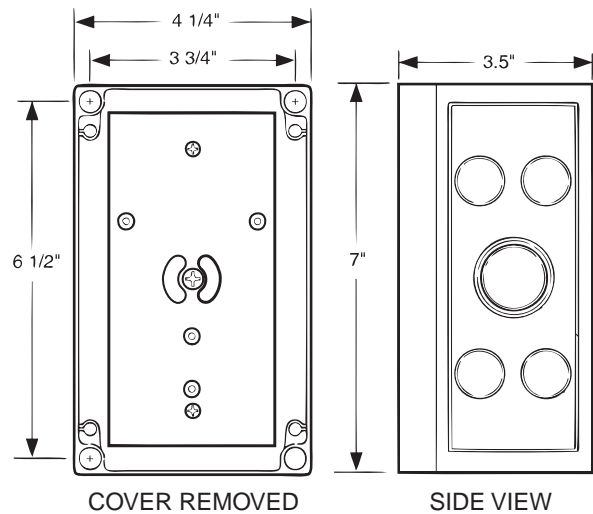

C07135

Fig. 44 - Outdoor Air Quality Sensor Cover

Wiring the Outdoor Air CO₂ Sensor: A dedicated power supply is required for this sensor. A two-wire cable is required to wire the dedicated power supply for the sensor. The two wires should be connected to the power supply and terminals 1 and 2.

To connect the sensor to the control, identify the positive (4 to 20 mA) and ground (SIG COM) terminals on the OAQ sensor. See Fig. 42. Connect the 4 to 20 mA terminal to the TB1-13 terminal of the 50KCQ. Connect the SIG COM terminal to the TB1-11 terminal of the 50KCQ. See Fig. 45.

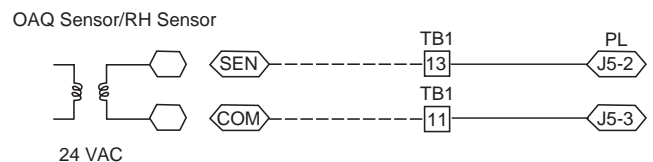

C08275

Fig. 45 - Outdoor CO₂ Sensor Connections

Space Relative Humidity Sensors —

Space Relative Humidity Sensors are not used with 50KCQ units at this time.

Smoke Detector/Fire Shutdown (FSD) —

This function is available only when PremierLink is configured for (Space) Sensor Mode. The unit is factory-wired for PremierLink FSD operation when PremierLink is factory-installed.

On 50KCQ units equipped with factory-installed Smoke Detector(s), the smoke detector controller implements the unit shutdown through its NC contact set connected to the unit's CTB input. The FSD function is initiated via the smoke detector's Alarm NO contact set. The PremierLink communicates the smoke detector's tripped status to the CCN building control. See Fig. 35 (PremierLink wiring schematic).

Filter Status Switch —

This function is available only when PremierLink is configured for (Space) Sensor Mode.

PremierLink control can monitor return filter status in two ways: By monitoring a field-supplied/installed filter pressure switch or via supply fan runtime hours.

Using switch input: Install the dirty filter pressure switch according to switch manufacturer's instructions, to measure pressure drop across the unit's return filters. Connect one side of the switch's NO contact set to CTB's THERMOSTAT-R terminal. Connect the other side of the NO contact set to TB1-10. Setpoint for Dirty Filter is set at the switch. See Fig. 46

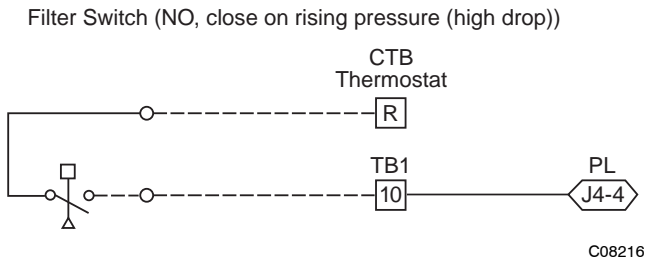

Fig. 46 - PremierLink Filter Switch Connection

When the filter switch's NO contact set closes as filter pressure drop increases (indicating dirt-laden filters), the input signal to PremierLink causes the filter status point to read "DIRTY".

Using Filter Timer Hours: Refer to Form 33SC-68SI for instructions on using the PremierLink Configuration screens and on unit alarm sequence.

Supply Fan Status Switch —

The PremierLink control can monitor supply fan operation through a field-supplied/installed differential pressure switch. This sequence will prevent (or interrupt) operation of unit cooling, heating and economizer functions until the pressure switch contacts are closed indicating proper supply fan operation.

Install the differential pressure switch in the supply fan section according to switch manufacturer's instructions. Arrange the switch contact to be open on no flow and to close as pressure rises indicating fan operation.

Connect one side of the switch's NO contact set to CTB's THERMOSTAT-R terminal. Connect the other side of the NO contact set to TB1-8. Setpoint for Supply Fan Status is set at the switch. See Fig. 47.

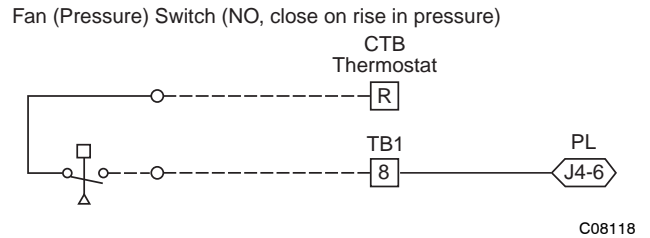

Fig. 47 - PremierLink Wiring Fan Pressure Switch Connection

Remote Occupied Switch —

The PremierLink control permits a remote timeclock to override the control's on-board occupancy schedule and place the unit into Occupied mode. This function may also provide a "Door Switch" time delay function that will terminate cooling and heating functions after a 2-20 minute delay.

Connect one side of the NO contact set on the timeclock to CTB's THERMOSTAT-R terminal. Connect the other side of the timeclock contact to the unit's TB1-2 terminal (see Fig. 48).

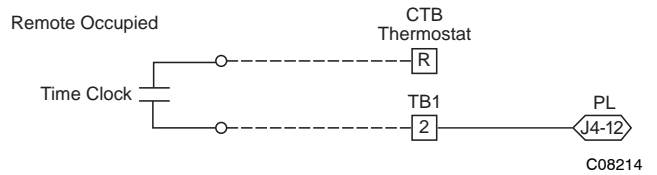

Fig. 48 - PremierLink Wiring Remote Occupied

Refer to Form 33SC-68SI for additional information on configuring the PremierLink control for Door Switch timer function.

Power Exhaust (output) —

Connect the accessory Power Exhaust contactor coils(s) per Fig. 49.

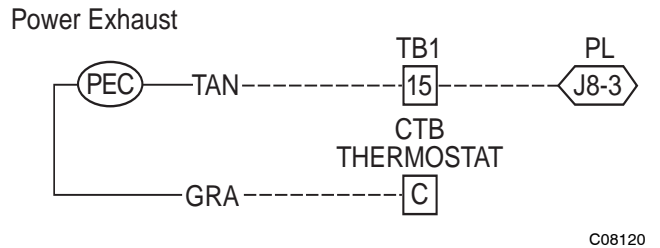

Fig. 49 - PremierLink Power Exhaust Output Connection

CCN Communication Bus —

The PremierLink controller connects to the bus in a daisy chain arrangement. Negative pins on each component must be connected to respective negative pins, and likewise, positive pins on each component must be connected to respective positive pins. The controller signal pins must be wired to the signal ground pins. Wiring connections for CCN must be made at the 3-pin plug.

At any baud (9600, 19200, 38400 baud), the number of controllers is limited to 239 devices maximum. Bus length may not exceed 4000 ft, with no more than 60 total devices on any 1000-ft section. Optically isolated RS-485 repeaters are required every 1000 ft.

NOTE: Carrier device default is 9600 band.

Communications Bus Wire Specifications: The CCN Communication Bus wiring is field-supplied and field-installed. It consists of shielded 3-conductor cable with drain (ground) wire. The cable selected must be identical to the CCN Communication Bus wire used for the entire network.

See Table 6 for recommended cable.

Table 6 – Recommended Cables

MANUFACTURER	CABLE PART NO.
Alpha	2413 or 5463
American	A22503
Belden	8772
Columbia	02525

NOTE: Conductors and drain wire must be at least 20 AWG, stranded, and tinned copper. Individual conductors must be insulated with PVC, PVC/nylon, vinyl, Teflon, or polyethylene. An aluminum/polyester 100% foil shield and an outer jacket of PVC, PVC/nylon, chrome vinyl, or Teflon with a minimum operating temperature range of -20°C to 60°C is required. Do not run communication wire in the same conduit as or next to any AC voltage wiring.

The communication bus shields must be tied together at each system element. If the communication bus is entirely within one building, the resulting continuous shield must be connected to ground at only one single point. If the communication bus cable exits from one building and enters another building, the shields must be connected to the grounds at a lightning suppressor in each building (one point only).

Connecting CCN bus:

NOTE: When connecting the communication bus cable, a color code system for the entire network is recommended to simplify installation and checkout. See Table 7 for the recommended color code.

Table 7 – Color Code Recommendations

SIGNAL TYPE	CCN BUS WIRE COLOR	CCN PLUG PIN NUMBER
+	Red	1
Ground	White	2
-	Black	3

Connect the CCN (+) lead (typically RED) to the unit's TB1-12 terminal. Connect the CCN (ground) lead (typically WHT) to the unit's TB1-14 terminal. Connect the CCN (-) lead (typically BLK) to the unit's TB1-16 terminal. See Fig. 50.

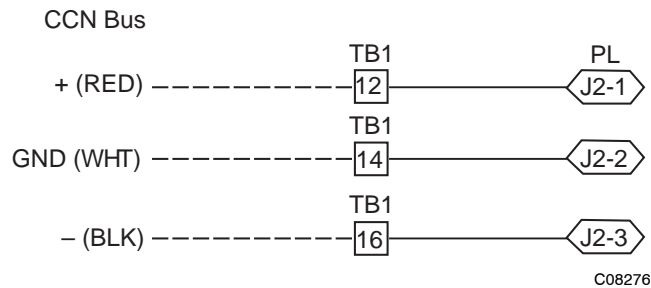

Fig. 50 - PremierLink CCN Bus Connections

RTU Open Control System

The RTU Open control is factory-mounted in the 50KCQ unit's main control box, to the left of the CTB. See Fig. 52. Factory wiring is completed through harnesses connected to the CTB. Field connections for RTU Open sensors will be made at the Phoenix connectors on the RTU Open board. The factory-installed RTU Open control includes the supply-air temperature (SAT) sensor. The outdoor air temperature (OAT) sensor is included in the FIOP/accessory EconoMi\$er2 package.

The RTU Open controller is an integrated component of the Carrier rooftop unit. Its internal application programming provides optimum performance and energy efficiency. RTU Open enables the unit to run in 100% stand-alone control mode, Carrier's i-Vu® Open network, or a Third Party Building Automation System (BAS). On-board DIP switches allow you to select your protocol (and baud rate) of choice among the four most popular protocols in use today: BACnet, Modbus, Johnson N2 and LonWorks. (See Fig. 51.)

Refer to Table 8, RTU Open Controller Inputs and Outputs for locations of all connections to the RTU Open board.

50KCQ

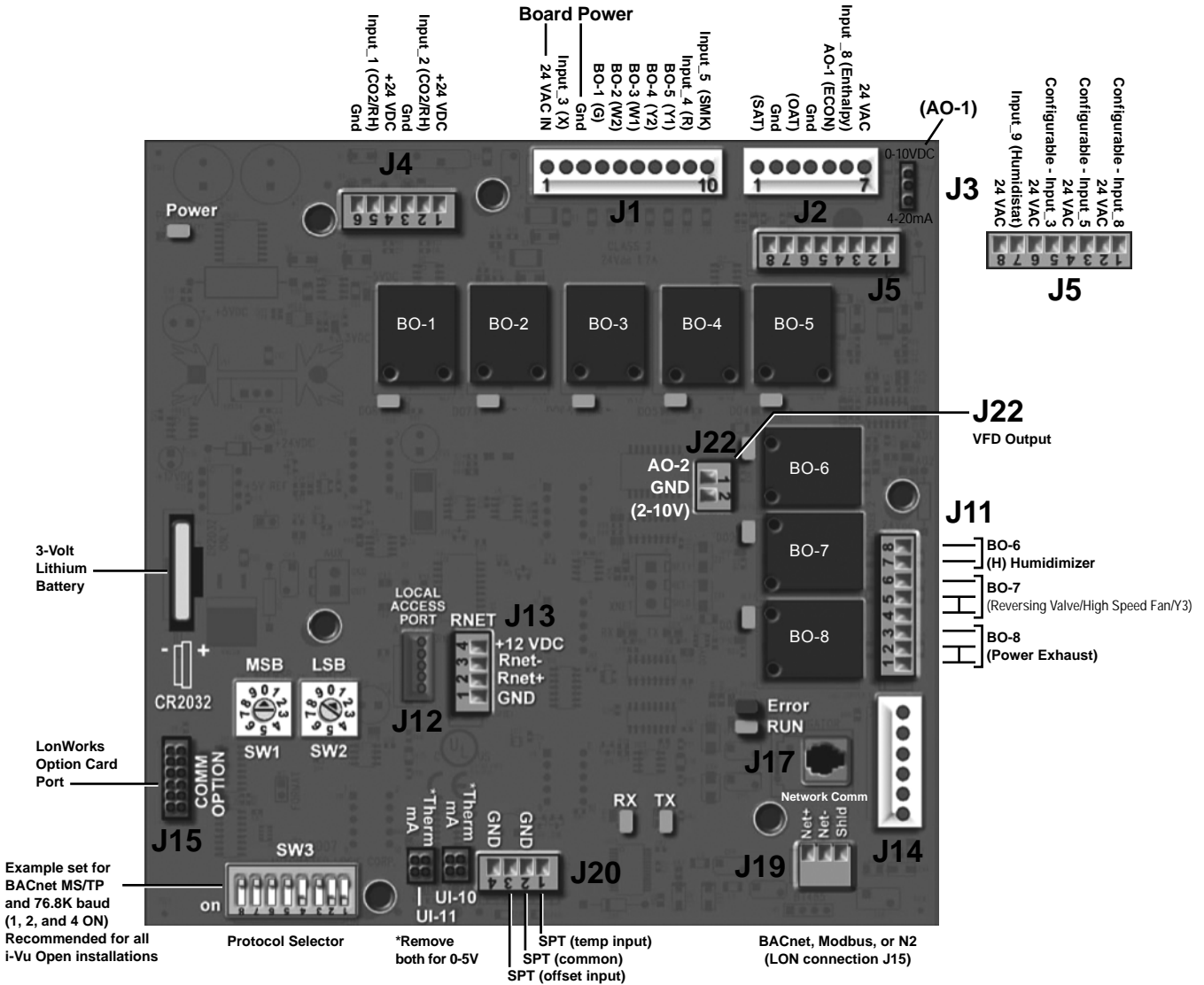

Fig. 51 - RTU Open Multi-Protocol Control Board

C14129

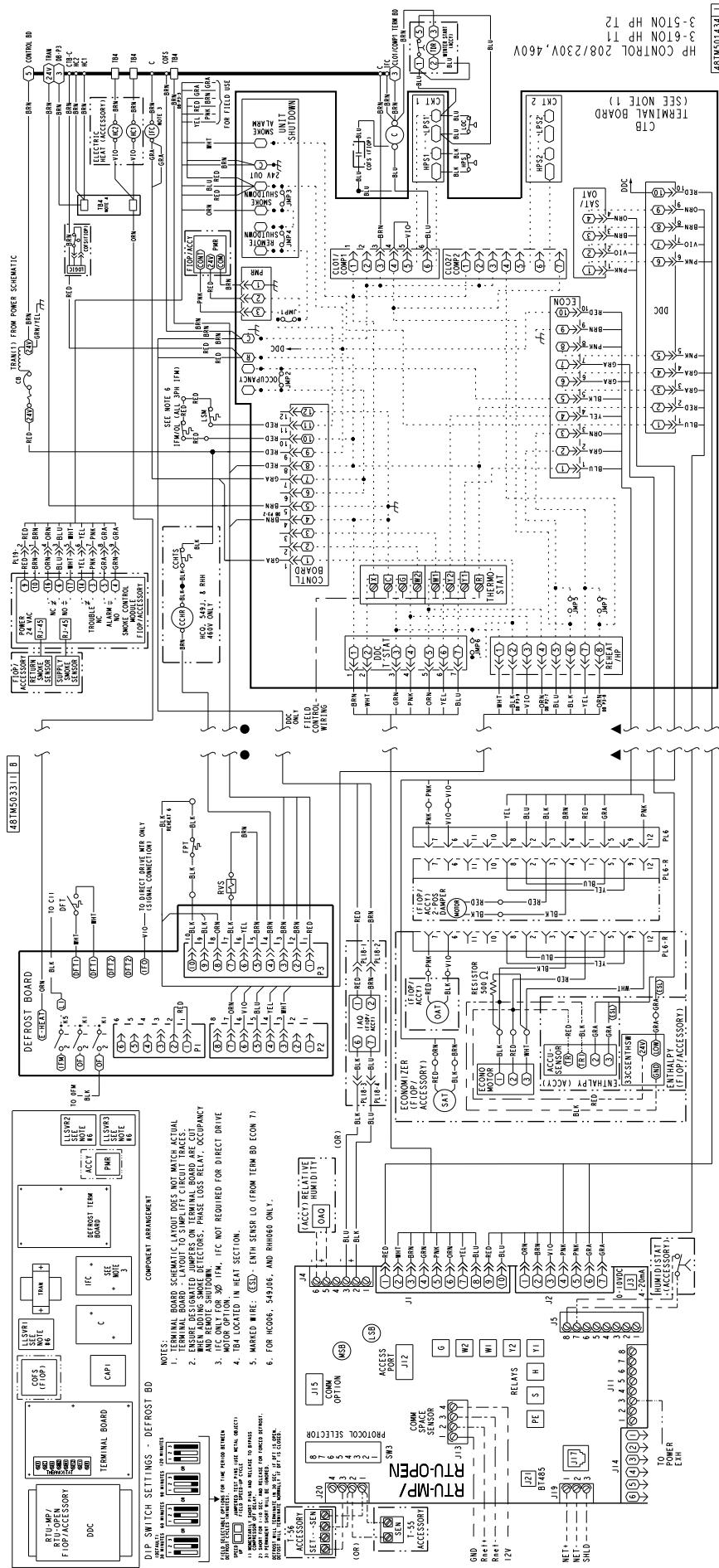

Fig. 52 - RTU Open System Control Wiring Diagram

50KCC

Table 8 – RTU Open Controller Inputs and Outputs

POINT NAME	BACnet OBJECT NAME	TYPE OF I/O	CONNECTION PIN NUMBER(S)	CHANNEL DESIGNATION
DEDICATED INPUTS				
Space Temp / Zone Temp	zone_temp	AI (10K Thermistor)	J20-1 & 2	Analog Input 10
Supply Air Temperature	sa_temp	AI (10K Thermistor)	J2-1 & 2	Analog Input 6
Outside Air Temperature	oa_temp	AI (10K Thermistor)	J2-3 & 4	Analog Input 7
Space Temperature Offset Pot	stpt_adj_offset	AI (100K Potentiometer)	J20-3 & 4	Analog Input 11
Safety Chain Feedback	safety_status	BI (24 VAC)	J1-9	Binary Input 4
Compressor Safety Status ⁽¹⁾	comp_status	BI (24 VAC)	J1-2	Binary Input 3
Fire Shutdown Status	firedown_status	BI (24 VAC)	J1-10	Binary Input 5
Enthalpy Status	enthalpy_status	BI (24 VAC)	J2-6 & 7	Binary Input 8
Humidistat Input Status	humstat_status	BI (24 VAC)	J5-7 & 8	Binary Input 9
Zone Temperature	n/a	n/a	J13-1-4	Rnet
CONFIGURABLE INPUTS ⁽⁴⁾				
Indoor Air CO2	iaq	AI (4-20 mA)	J4-2 & 3 or J4-5 & 6	Analog Input 2
Outdoor Air CO2	oaq	AI (4-20 mA)		Analog Input 1
Space Relative Humidity	space_rh	AI (4-20 mA)		Analog Input 10
Supply Fan Status ⁽²⁾	sfan_status	BI (24 VAC)	J5-1 & 2 or J5-3 & 4, J5-5 & 6 or J5-7 & 8 ⁽³⁾	Binary Input 3, 5, 8, or 9, except where intrinsic input is used
Filter Status ⁽²⁾	filter_status	BI (24 VAC)		Binary Input 3, 5, 8, or 9, except where intrinsic input is used
Door Contact ⁽²⁾	door_contact_status	BI (24 VAC)		Binary Input 3, 5, 8, or 9, except where intrinsic input is used
Remote Occupancy input ⁽²⁾	occ_contact_status	BI (24 VAC)		Binary Input 3, 5, 8, or 9, except where intrinsic input is used
IGC input ⁽²⁾	igcovr_status	BI (24 VAC)		Binary Input 9. Mandatory input on gas heat units.
OUTPUTS				
Economizer Output	econ_output	AO (4-20mA)	J2-5	Analog Output 1
Supply Fan VFD	vfd_output	AO (2-10Vdc)	J22-1 & 2	Analog Output 2
Supply Fan Relay	sfan	BO Relay (24VAC, 1A)	J1-4	Binary Output 1 (G)
Cool 1 Relay State	comp_1	BO Relay (24VAC, 1A)	J1-8	Binary Output 5 (Y1)
Cool 2 Relay State	comp_2	BO Relay (24VAC, 1A)	J1-7	Binary Output 4 (Y2)
Cool 3 Relay State	comp_3	BO Relay (24VAC, 1A)	J11-5 & 6	Binary Output 7 (Y3)
Heat 1 Relay State	heat_1	BO Relay (24VAC, 1A)	J1-6	Binary Output 3 (W1)
Heat 2 Relay State	heat_2	BO Relay (24VAC, 1A)	J1-5	Binary Output 2 (W2)
Power Exhaust Relay State	pexh	BO Relay (24VAC, 1A)	J11-2 & 3 (N.O.)	Binary Output 8 (PE)
Dehumidification Relay	dehum	BO Relay (24VAC, 1A)	J11-7 & 8 (N.O.)	Binary Output 6

LEGEND

- AI – Analog Input
- AO – Analog Output
- BI – Binary Input
- BO – Binary Output

⁽¹⁾ Safety Chain Feedback: 24Vac required at this terminal to provide "Run Enable" status. See Input/Output section for additional instructions.

⁽²⁾ These inputs are configurable. If installed, they take the place of the default input on the specific channel. See appropriate Input Configuration Section for wiring and setup instructions.

⁽³⁾ Parallel pins J5-1 = J2-6, J5-3 = J1-10, J5-5 = J1-2 are used for field installation.

⁽⁴⁾ Refer to the input configuration and accessory sections of the RTU Open Multi-Protocol Controller Controls, Start-Up, Operation and Troubleshooting manual for more detail.

50KCQ

The RTU Open controller requires the use of a Carrier space sensor. A standard thermostat cannot be used with the RTU Open system.

Supply Air Temperature (SAT) Sensor —

On FIOP-equipped 50KCQ unit, the unit is supplied with a supply-air temperature (SAT) sensor (33ZCSENSAT). This sensor is a tubular probe type, approx 6-inches (152 mm) in length. It is a nominal 10-k ohm thermistor.

The SAT is factory-wired. The SAT probe is wire-tied to the supply-air opening (on the horizontal opening end) in its shipping position. Remove the sensor for installation. Re-position the sensor in the flange of the supply-air opening or in the supply air duct (as required by local codes). Drill or punch a 1/2-in. hole in the flange or duct. Use two field-supplied, self-drilling screws to secure the sensor probe in a horizontal orientation. See Fig. 36.

Outdoor Air Temperature (OAT) Sensor —

The OAT is factory-mounted in the EconoMiSer2 (FIOP or accessory). It is a nominal 10k ohm thermistor attached to an eyelet mounting ring.

EconoMiSer2 —

The RTU Open control is used with EconoMiSer2 (option or accessory) for outdoor air management. The damper position is controlled directly by the RTU Open control; EconoMiSer2 has no internal logic device.

Outdoor air management functions can be enhanced with field-installation of these accessory control devices:

- Enthalpy control (outdoor air or differential sensors)
- Space CO₂ sensor
- Outdoor air CO₂ sensor

Field Connections

Field connections for accessory sensors and input devices are made the RTU Open, at plugs J1, J2, J4, J5, J11 and J20. All field control wiring that connects to the RTU Open must be routed through the raceway built into the corner post as shown in Fig. 26. The raceway provides the UL required clearance between high- and low-voltage wiring. Pass the control wires through the hole provided in the corner post, then feed the wires thorough the raceway to the RTU Open. Connect to the wires to the removable Phoenix connectors and then reconnect the connectors to the board.

Space Temperature (SPT) Sensors —

There are two types of SPT sensors available from Carrier, resistive input non-communicating (T55, T56, and T59) and Rnet communicating (SPS, SPPL, SPP, and SPPF) sensors. Each type has a variety of options consisting of: timed override button, set point adjustment, a LCD screen, and communication tie in. Space temperature can be also be written to from a building network or zoning system. However, it is still recommended that return air duct sensor be installed to allow stand-alone operation for back-up. Refer to the configuration section for details on controller configurations associated with space sensors.

- 33ZCT55SPT, space temperature sensor with override button
- 33ZCT56SPT, space temperature sensor with override button and setpoint adjustment
- 33ZCT59SPT, space temperature sensor with LCD (liquid crystal display) screen, override button, and setpoint adjustment

Use 20 gauge wire to connect the sensor to the controller. The wire is suitable for distances of up to 500 ft. Use a three-conductor shielded cable for the sensor and setpoint connections. If the setpoint adjustment (slidebar) is not required, then an unshielded, 18 or 20 gauge, two-conductor, twisted pair cable may be used.

Connect T-55: See Fig. 37 for typical T-55 internal connections. Connect the T-55 SEN terminals to RTU Open J20-1 and J20-2. See Fig. 53.

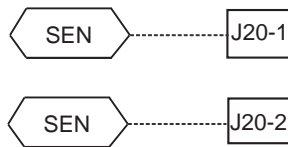

Fig. 53 - RTU Open T-55 Sensor Connections

C08460

Connect T-56: See Fig. 39 for T-56 internal connections. Install a jumper between SEN and SET terminals as illustrated. Connect T-56 terminals to RTU Open J20-1, J20-2 and J20-3 per Fig. 54.

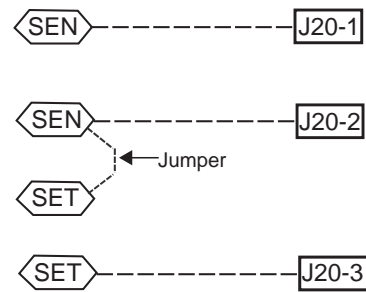
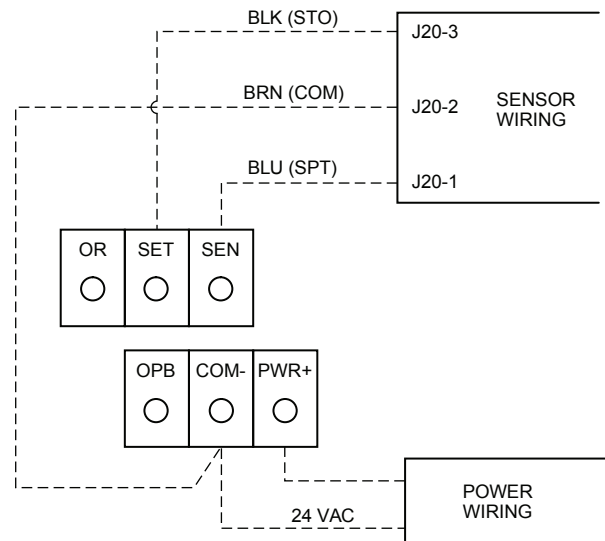

Fig. 54 - RTU Open T-56 Sensor Connections

C08461

Connect T-59: The T-59 space sensor requires a separate, isolated power supply of 24 VAC. See Fig. 55 for internal connections at the T-59. Connect the SEN terminal (BLU) to RTU Open J20-1. Connect the COM terminal (BRN) to J20-2. Connect the SET terminal (STO or BLK) to J20-3.



NOTE: Must use a separate isolated transformer.

Fig. 55 - Space Temperature Sensor Typical Wiring (33ZCT59SPT)

C10291

Indoor Air Quality (CO₂) Sensor —

The indoor air quality sensor accessory monitors space carbon dioxide (CO₂) levels. This information is used to monitor IAQ levels. Several types of sensors are available, for wall mounting in the space or in return duct, with and without LCD display, and in combination with space temperature sensors. Sensors use infrared technology to measure the levels of CO₂ present in the space air.

The CO₂ sensors are all factory set for a range of 0 to 2000 ppm and a linear mA output of 4 to 20. Refer to the instructions supplied with the CO₂ sensor for electrical requirements and terminal locations. See Fig. 42 for typical CO₂ sensor wiring schematic.

To accurately monitor the quality of the air in the conditioned air space, locate the sensor near a return-air grille (if present) so it senses the concentration of CO₂ leaving the space. The sensor should be mounted in a location to avoid direct breath contact.

Do not mount the IAQ sensor in drafty areas such as near supply ducts, open windows, fans, or over heat sources. Allow at least 3 ft (0.9 m) between the sensor and any corner. Avoid mounting the sensor where it is influenced by the supply air; the sensor gives inaccurate readings if the supply air is blown directly onto the sensor or if the supply air does not have a chance to mix with the room air before it is drawn into the return airstream.

Wiring the Indoor Air Quality Sensor: For each sensor, use two 2-conductor 18 AWG (American Wire Gage) twisted-pair cables (unshielded) to connect the separate isolated 24 vac power source to the sensor and to connect the sensor to the control board terminals.

To connect the sensor to the control, identify the positive (4 to 20 mA) and ground (SIG COM) terminals on the sensor. See Fig. 42. Connect the 4-20 mA terminal to RTU Open J4-2 and connect the SIG COM terminal to RTU Open J4-3. See Fig. 56.

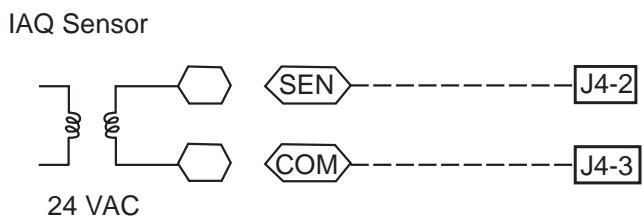

C08462

Fig. 56 - RTU Open / Indoor CO₂ Sensor (33ZCSENCO2) Connections

Outdoor Air Quality Sensor (PNO 33ZCSENCO2 plus weatherproof enclosure) —

The outdoor air CO₂ sensor is designed to monitor carbon dioxide (CO₂) levels in the outside ventilation air and interface with the ventilation damper in an HVAC system. The OAQ sensor is packaged with an outdoor cover. See Fig. 44. The outdoor air CO₂ sensor must be located in the economizer outside air hood.

Wiring the Outdoor Air CO₂ Sensor: A dedicated power supply is required for this sensor. A two-wire cable is required to wire the dedicated power supply for the sensor. The two wires should be connected to the power supply and terminals 1 and 2.

To connect the sensor to the control, identify the positive (4 to 20 mA) and ground (SIG COM) terminals on the OAQ sensor. See Fig. 42. Connect the 4 to 20 mA terminal to RTU Open J4-5. Connect the SIG COM terminal to RTU Open J4-6.

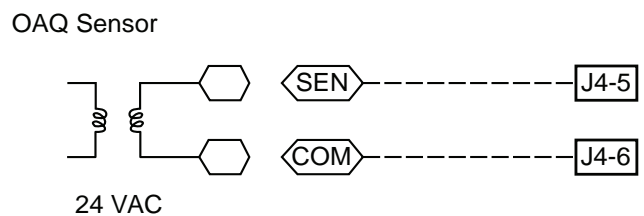

C11086

Fig. 57 - RTU Open / Outdoor CO₂ Sensor (33ZCSENCO2) Connections

Space Relative Humidity Sensor—

The Space Relative Humidity Sensor is not used with 50KCQ units at this time.

Smoke Detector/Fire Shutdown (FSD) —

On 50KCQ units equipped with factory-installed Smoke Detector(s), the smoke detector controller implements the unit shutdown through its NC contact set connected to the unit’s CTB input. The FSD function is initiated via the smoke detector’s Alarm NO contact set. The RTU Open controller communicates the smoke detector’s tripped status to the BAS building control. See Fig. 52 (RTU Open System Control wiring schematics).

The Fire Shutdown Switch configuration, *MENU* → *Config* → *Inputs* → *input 5*, identifies the normally open status of this input when there is no fire alarm.

Connecting Discrete Inputs —

Filter Status: The filter status accessory is a field-installed accessory. This accessory detects plugged filters. When installing this accessory, the unit must be configured for filter status by setting *MENU* → *Config* → *Inputs* → *input 3, 5, 8, or 9* to Filter Status and normally open (N/O) or normally closed (N/C). Input 8 or 9 is recommended for easy of installation. Refer to Fig. 51 and Fig. 52 for wire terminations at J5.

Fan Status: The fan status accessory is a field-installed accessory. This accessory detects when the indoor fan is blowing air. When installing this accessory, the unit must be configured for fan status by setting *MENU* → *Config* → *Inputs* → *input 3, 5, 8, or 9* to Fan Status and normally open (N/O) or normally closed (N/C). Input 8 or 9 is recommended for easy of installation. Refer to Fig. 51 and Fig. 52 for wire terminations at J5.

Remote Occupancy: The remote occupancy accessory is a field-installed accessory. This accessory overrides the unoccupied mode and puts the unit in occupied mode. When installing this accessory, the unit must be configured for remote occupancy by setting *MENU* → *Config* → *Inputs* → *input 3, 5, 8, or 9* to Remote Occupancy and normally open (N/O) or normally closed (N/C).

Also set *MENU* → *Schedules* → *occupancy source* to DI on/off. Input 8 or 9 is recommended for easy of installation. Refer to Fig. 51 and Table 8 for wire terminations at J5.

Power Exhaust (output): The relay used by the RTU Open board to control power exhaust is a dry contact which means it does not have 24vac. This 24vac must be connected to the relay to allow it to operate the power exhaust relay in the PE accessory. A 24vac source must be provided to J11-2 on the RTU Open control board. This can be provided by the unit’s transformer from various sources. The “R” terminal on the unit’s low voltage terminal board (LVTB) is a logical source. Refer to Fig. 51 and Fig. 52 for wire terminations at J11.

Communication Wiring - Protocols

General —

Protocols are the communication languages spoken by control devices. The main purpose of a protocol is to communicate information in the most efficient method possible. Different protocols exist to provide different kinds of information for different applications. In the BAS application, many different protocols are used, depending on manufacturer. Protocols do not change the function of a controller; just make the front end user different.

The RTU Open can be set to communicate on four different protocols: BACnet, Modbus, N2, and LonWorks.

Switch 3 (SW3) on the board is used to set protocol and baud rate. Switches 1 and 2 (SW1 and SW2) are used to set the board's network address. See Fig. 58 and 59 for protocol switch settings and address switches. The 3rd party connection to the RTU Open is through plug J19. See Fig. 60 for wiring.

NOTE: Power must be cycled after changing the SW1-3 switch settings.

Refer to the *RTU Open v3 Integration Guide* for more detailed information on protocols, 3rd party wiring, and networking.

SW3 Protocol Selection

PROTOCOL	DS8	DS7	DS6	DS5	DS4	DS3	DS2	DS1
BACnet MS/TP (Master)	Unused	OFF	OFF	OFF	ON	OFF	Select Baud	Select Baud
Modbus (Slave)	Unused	OFF	OFF	ON	ON	OFF	Select Baud	Select Baud
N2 (Slave)	Unused	OFF	OFF	OFF	ON	ON	OFF	OFF
LonWorks	Unused	ON	ON	OFF	ON	OFF	OFF	ON

NOTE:

DS = Dip Switch

BACnet MS/TP SW3 example shown

Baud Rate Selections

BAUD RATE	DS2	DS1
9600	OFF	OFF
19,200	ON	OFF
38,400	OFF	ON
76,800	ON	ON

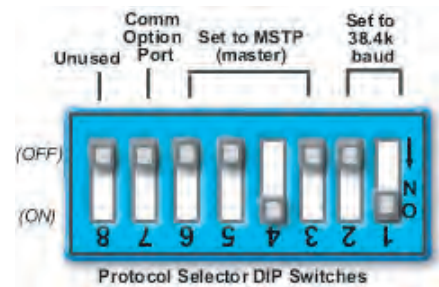

C07166

Fig. 58 - RTU Open SW3 Dip Switch Settings



C10815

Fig. 59 - RTU Open Address Switches

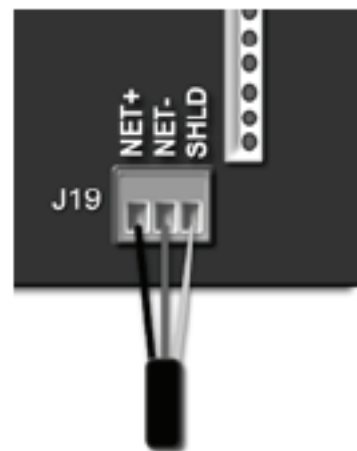

C10816

Fig. 60 - Network Wiring

Local Access

Wall Mounted Equipment Touch

The Equipment Touch is a wall mounted interface used to connect to the RTU Open to access the control information, read sensor values, and maintenance. This is an accessory interface that does not come with the RTU Open controller. You wire the Equipment Touch to the RTU Open's J13 local access port. There are 2 password protected levels in the display (User and Admin). See the Equipment Touch Installation and Setup Guide for more information. See Appendix A for navigation and screen content.

Field Assistant

Field Assistant is a computer program included with the purchase of the Tech Tool Kit (USB-TKIT). This is a field Tech Tool to set-up, service, or download application software to the RTU Open controller and includes a USB Link Cable. The link cable connects a USB port to the J12 local access port. The Field Assistant's menu structure is similar and functions the same as i-Vu[®]. See Fig. 61.

RTU Open Troubleshooting —

Communication LEDs: The LEDs indicate if the controller is speaking to the devices on the network. The LEDs should reflect communication traffic based on the baud rate set. The higher the baud rate the more solid the LEDs will appear. See Table 9.

50KCC

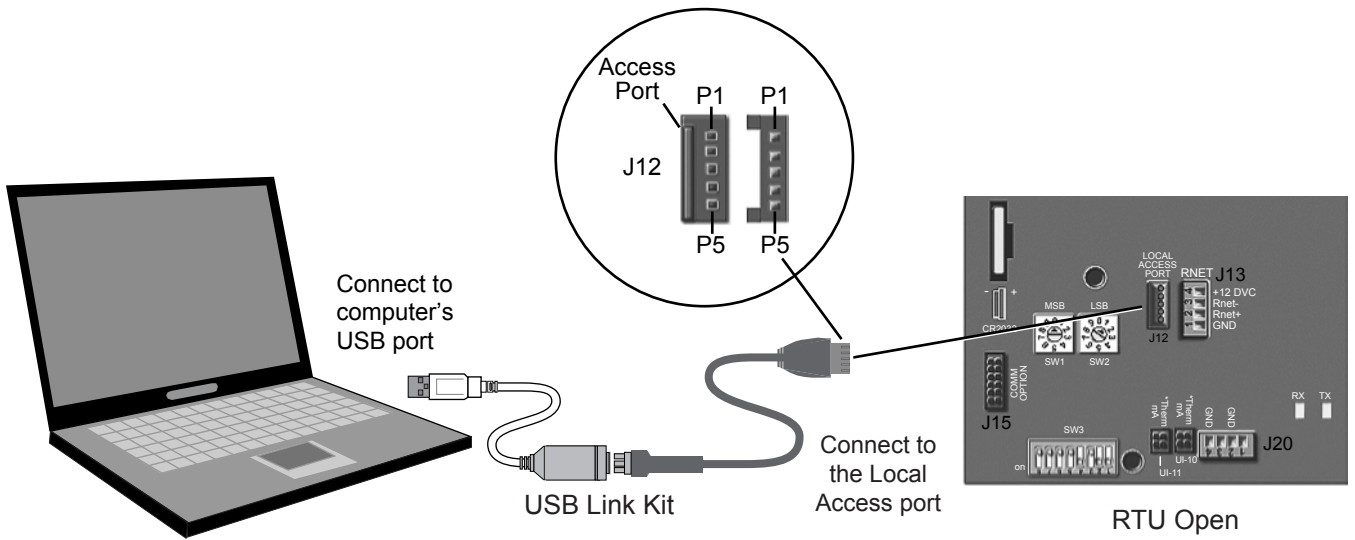

Fig. 61 - PC Running Field Assistant

C14131

Table 9 – LEDs

The LEDs on the RTU Open show the status of certain functions

If this LED is on...	Status is...
Power	The RTU Open has power
Rx	The RTU Open is receiving data from the network segment
Tx	The RTU Open is transmitting data over the network segment
BO#	The binary output is active

The **Run** and **Error** LEDs indicate control module and network status

If Run LED shows...	And Error LED shows...	Status is...
2 flashes per second	Off	Normal
2 flashes per second	2 flashes, alternating with Run LED	Five minute auto–restart delay after system error
2 flashes per second	3 flashes, then off	Control module has just been formatted
2 flashes per second	4 flashes, then pause	Two or more devices on this network have the same MSTP network address
2 flashes per second	On	Exec halted after frequent system errors or control programs halted
5 flashes per second	On	Exec start–up aborted, Boot is running
5 flashes per second	Off	Firmware transfer in progress, Boot is running
7 flashes per second	7 flashes per second, alternating with Run LED	Ten second recovery period after brownout
14 flashes per second	14 flashes per second, alternating with Run LED	Brownout
On	On	Failure. Try the following solutions: <ul style="list-style-type: none"> • Turn the RTU Open off, then on. • Format the RTU Open. • Download memory to the RTU Open. • Replace the RTU Open.

50KCG

NOTE: Refer to the *RTU Open Multi-Protocol Controller Controls, Start-Up, Operation and Troubleshooting* manual for complete configuration of RTU Open, operating sequences and troubleshooting information. Refer to the *RTU Open v3 Integration Guide* for details on configuration and troubleshooting of connected networks. Have a copy of these manuals available at unit start-up.

Outdoor Air Enthalpy Control (PNO 33CSENTHSW)

The enthalpy control (33CSENTHSW) is available as a field-installed accessory to be used with the EconoMi\$er2 damper system. The outdoor air enthalpy sensor is part of the enthalpy control. (The separate field-installed accessory return air enthalpy sensor (33CSENSEN) is required for differential enthalpy control. See Fig. 62.)

Locate the enthalpy control in the economizer next to the Actuator Motor. Locate two GRA leads in the factory harness and connect the gray lead labeled “ESL” to the terminal labeled “LOW”. See Fig. 62. Connect the enthalpy control power input terminals to economizer actuator power leads RED (connect to 24V) and BLK (connect to GND).

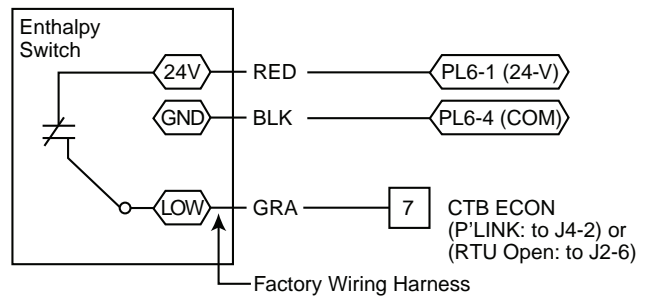

Fig. 62 - Enthalpy Switch (33CSENTHSW) Connections

C11160

The outdoor enthalpy changeover setpoint is set at the enthalpy controller.

Differential Enthalpy Control —

Differential enthalpy control is provided by sensing and comparing the outside air and return air enthalpy conditions. Install the outdoor air enthalpy control as described above. Add and install a return air enthalpy sensor.

Return Air Enthalpy Sensor —

Mount the return-air enthalpy sensor (33CSENTSEN) in the return-air section of the economizer. The return air sensor is wired to the enthalpy controller (33CSENTHSW). See Fig. 63.

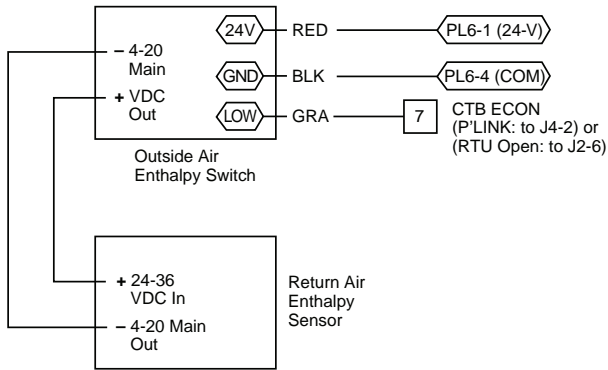

C11161

Fig. 63 - Outside and Return Air Enthalpy Sensor Wiring

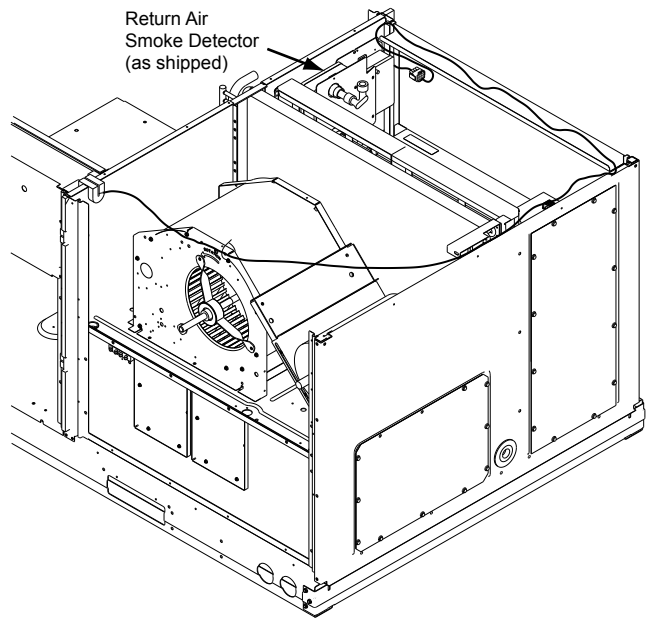

C12282

Fig. 64 - Return Air Smoke Detector, Shipping Position

Smoke Detectors

Smoke detectors are available as factory-installed options on 48KC models. Smoke detectors may be specified for Supply Air only or for Return Air without or with economizer or in combination of Supply Air and Return Air. All components necessary for operation are factory-provided and mounted. The unit is factory-configured for immediate smoke detector shutdown operation; additional wiring or modifications to unit terminal board may be necessary to complete the unit and smoke detector configuration to meet project requirements.

Units equipped with factory-optional Return Air smoke detectors require a relocation of the sensor module at unit installation. See Fig. 64 for the as shipped location.

Completing Installation of Return Air Smoke Sensor:

1. Unscrew the two screws holding the Return Air Smoke Detector assembly. See Fig. 65, Step 1. Save the screws.
2. Turn the assembly 90 and then rotate end to end. Make sure that the elbow fitting is pointing down. See Fig. 65, Step 2.
3. Screw the sensor and detector plate into its operating position using screws from Step 1. See Fig. 65, Step 3.
4. Connect the flexible tube on the sampling inlet to the sampling tube on the basepan.

Additional Application Data —

Refer to Catalog No. HKRNKA-1XA for discussions on additional control features of these smoke detectors including multiple unit coordination.

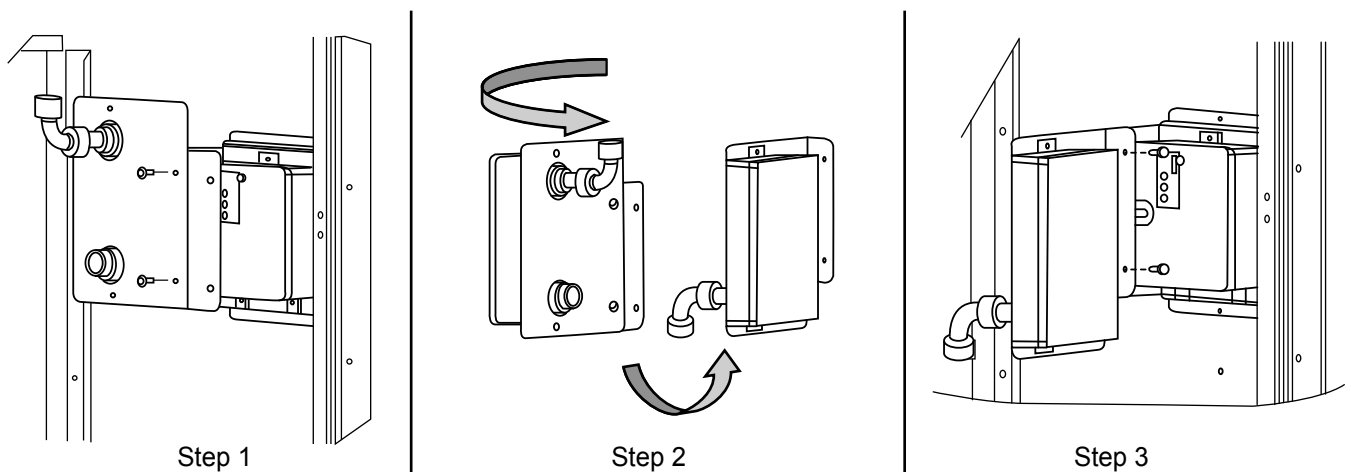

C12283

Fig. 65 - Completing Installation of Return Air Smoke Sensor

Table 10 – Unit Wire/Fuse or HACR Breaker Sizing Data

UNIT	NO M. V-PH-HZ	ELEC. HTR				NO C.O. or UNPWR C.O.										w/ PWRD C.O.									
		IFM TYPE	CRHEATER***A00	Nom (kW)	FLA	NO PE.					w/ PE. (pwrdr fr/unit)					NO PE.					w/ PE. (pwrdr fr/unit)				
						MCA	MAX FUSE or HACR BRKR	FLA	LRA	DISC. SIZE	MCA	MAX FUSE or HACR BRKR	FLA	LRA	DISC. SIZE	MCA	MAX FUSE or HACR BRKR	FLA	LRA	DISC. SIZE	MCA	MAX FUSE or HACR BRKR	FLA	LRA	DISC. SIZE
50KCA04	208/230-1-60	DD-STD	NONE	-	-	30	45	29	88	32	31	90	34	50	34	93	36	50	36	95	36	50	36	95	
			101A	3.3/4.4	15.9/18.3	49/52	60/60	47/50	104/106	51/54	60/60	49/52	106/108	54/57	60/60	53/55	109/111	56/59	60/60	55/58	111/113				
			102A	4.9/6.5	23.5/27.1	59/63	60/70	56/60	112/115	61/65	70/70	58/62	114/117	64/68	70/70	61/65	117/120	66/70	70/70	63/68	119/122				
			103B	6.5/8.7	31.4/36.3	69/75	70/80	65/70	119/124	71/77	80/80	67/73	121/126	74/80	80/80	70/76	124/129	76/82	80/90	73/78	126/131				
			104B	7.9/10.5	37.9/43.8	77/84	80/90	72/79	126/132	79/86	80/90	75/81	128/134	82/89	90/90	78/85	131/137	84/91	90/100	80/87	133/139				
			102A-1-102A	9.8/13.0	46.9/54.2	88/97	90/100	83/91	182/196	90/99	90/100	85/93	184/198	93/102	100/110	88/97	187/201	95/104	100/110	90/99	189/203				
			NONE	-	-	22	30	22	82	24	24	24	84	27	30	27	87	29	35	29	89				
			101A	3.3/4.4	9.2/10.6	33/35	40/40	32/34	91/93	35/37	40/40	34/36	93/95	38/40	45/45	38/39	96/98	40/42	45/45	40/42	98/100				
			102A	4.9/6.5	13.6/15.6	39/41	45/45	37/40	96/98	41/43	45/45	39/42	98/100	44/46	50/50	43/45	101/103	46/48	50/50	45/47	103/105				
			103B	6.5/8.7	18.1/20.9	44/48	45/50	42/46	100/103	46/50	50/50	45/48	102/105	49/53	50/60	48/51	105/108	51/55	60/60	50/53	107/110				
104B	7.9/10.5	21.9/25.3	49/53	50/60	47/51	104/107	51/55	60/60	49/53	106/109	54/58	60/60	52/56	109/112	56/60	60/60	55/58	111/114							
105A	12.0/16.0	33.4/38.5	64/70	70/70	60/66	115/121	66/72	70/80	62/68	117/123	68/75	70/80	66/71	120/126	70/77	70/80	68/74	122/128							
208/230-3-60	50KCA04	MED	NONE	-	-	20/19	25/25	19/19	111	22/21	21/21	113	24/24	30/30	25/24	116	26/26	30/30	27/26	118					
			101A	3.3/4.4	9.2/10.6	31/33	35/35	30/31	120/122	33/35	40/40	32/33	122/124	36/37	40/40	35/36	125/127	38/39	45/45	37/39	127/129				
			102A	4.9/6.5	13.6/15.6	37/39	40/40	35/37	125/127	39/41	45/45	37/39	127/129	41/44	45/45	40/42	130/132	43/46	45/50	42/44	132/134				
			103B	6.5/8.7	18.1/20.9	42/45	45/50	40/43	129/132	44/47	45/50	42/45	131/134	47/50	50/50	45/48	134/137	49/52	50/60	48/50	136/139				
			104B	7.9/10.5	21.9/25.3	47/51	50/60	44/48	133/136	49/53	50/60	46/50	135/138	52/56	60/60	50/53	138/141	54/58	60/60	52/56	140/143				
105A	12.0/16.0	33.4/38.5	61/67	70/70	58/63	144/150	63/69	70/70	60/65	146/152	66/72	70/80	63/69	149/155	68/74	70/80	65/71	151/157							
HIGH	208/230-1-60	DD-STD	NONE	-	-	23/23	30/30	23/23	147	25/25	25/25	149	28/28	30/30	28/28	152	30/29	35/35	30/30	154					
			101A	3.3/4.4	9.2/10.6	34/36	40/40	33/35	156/158	36/38	40/45	36/37	158/160	39/41	45/45	39/40	161/163	41/43	45/45	41/43	163/165				
			102A	4.9/6.5	13.6/15.6	40/42	45/45	38/41	161/163	42/44	45/50	41/43	163/165	45/47	50/50	44/46	166/168	47/49	50/50	46/48	168/170				
			103B	6.5/8.7	18.1/20.9	45/49	50/50	44/47	165/168	47/51	50/60	46/49	167/170	50/54	50/60	49/52	170/173	52/56	60/60	51/54	172/175				
			104B	7.9/10.5	21.9/25.3	50/54	50/60	48/52	169/172	52/56	60/60	50/54	171/174	55/59	60/60	53/57	174/177	57/61	60/70	56/59	176/179				
105A	12.0/16.0	33.4/38.5	65/71	70/80	61/67	180/186	67/73	70/80	63/69	182/188	69/76	70/80	67/72	185/191	71/78	80/80	69/75	187/193							

See "Legend and Notes for Table 10 on page 43.



Table 10 – Unit Wire/Fuse or HACR Breaker Sizing Data (cont)

UNIT	NO M. V.-Ph-HZ	IFM TYPE	ELEC. HTR			NO C.O. or UNPWR C.O.						w/ PWRD C.O.										
			CRHEATER***A00	Nom (kW)	FLA	NO PE.			w/ PE. (pwrd fr/unit)			NO PE.			w/ PE. (pwrd fr/unit)							
						MCA	MAX FUSE or HACR BRKR	DISC. SIZE FLA LRA	MCA	MAX FUSE or HACR BRKR	DISC. SIZE FLA LRA	MCA	MAX FUSE or HACR BRKR	DISC. SIZE FLA LRA	MCA	MAX FUSE or HACR BRKR	DISC. SIZE FLA LRA					
50KCA04	460-3-60	DD-STD	NONE	-	-	12	15	13	13	15	13	44	14	20	14	45	15	20	16	46		
			106A	6.0	7.2	21	25	21	21	25	23	51	23	23	25	23	52	24	25	24	53	
			107A	8.8	10.6	25	30	24	26	25	30	25	55	28	30	30	27	56	29	30	28	57
			108A	11.5	13.8	29	35	28	30	29	35	58	32	30	35	35	30	59	33	35	31	60
			109A	14.0	16.8	33	35	31	34	32	35	61	35	34	35	35	34	62	36	40	35	63
50KCA04	460-3-60	MED	NONE	-	-	11	15	11	11	15	11	58	13	15	13	59	14	15	14	60		
			106A	6.0	7.2	20	20	18	21	25	20	65	22	25	21	25	66	23	25	22	67	
			107A	8.8	10.6	24	25	22	25	23	25	69	26	30	30	25	70	27	30	26	71	
			108A	11.5	13.8	28	30	26	29	27	30	72	30	29	30	29	73	31	35	30	74	
			109A	14.0	16.8	32	35	29	33	31	35	75	34	35	35	32	76	35	35	33	77	
50KCA04	460-3-60	HIGH	NONE	-	-	12	15	13	13	15	13	76	15	20	15	77	16	20	16	78		
			106A	6.0	7.2	21	25	20	22	25	83	24	25	23	25	84	25	25	24	85		
			107A	8.8	10.6	26	30	24	27	25	30	87	28	30	27	88	29	30	28	89		
			108A	11.5	13.8	30	30	28	31	29	35	90	32	35	30	30	91	33	35	32	92	
			109A	14.0	16.8	33	35	31	34	33	35	93	36	40	34	40	94	37	40	35	95	
575-3-60	575-3-60	DD-STD	NONE	-	-	10	15	12	12	15	44	11	15	12	44	13	15	14	46			
			NONE	-	-	7	15	9	9	15	47	9	15	9	47	11	15	11	49			
			NONE	-	-	8	15	10	10	15	62	10	15	10	62	12	15	12	64			

See "Legend and Notes for Table 10 on page 43.

Table 10 – Unit Wire/Fuse or HACR Breaker Sizing Data (cont)

UNIT	NO M. V.-Ph-HZ	IFM TYPE	ELEC. HTR			NO C.O. or UNPWR C.O.						w/ PWRD C.O.												
			CRHEATER***A00	Nom (kW)	FLA	NO PE.			w/ PE. (pwrd fr/unit)			NO PE.			w/ PE. (pwrd fr/unit)									
						MCA	MAX FUSE or HACR BRKR	DISC. SIZE FLA LRA	MCA	MAX FUSE or HACR BRKR	DISC. SIZE FLA LRA	MCA	MAX FUSE or HACR BRKR	DISC. SIZE FLA LRA	MCA	MAX FUSE or HACR BRKR	DISC. SIZE FLA LRA							
50KCA05	208/230-1-60	DD-STD	NONE	-	-	37	50	35	35	127	38	50	37	129	41	60	41	132	43	43	43	134		
			101A	3.3/4.4	15.9/18.3	56/59	60/60	53/56	143/145	58/61	60/70	56/58	60/70	56/58	145/147	61/64	70/80	59/62	148/150	63/66	80/80	61/64	150/152	
			103B	6.5/8.7	31.4/36.3	76/82	80/90	71/77	158/163	78/84	80/90	73/79	80/90	80/90	160/165	81/87	90/90	77/82	163/168	82/89	90/100	79/85	165/170	
			102A+102A	9.8/13.0	46.9/54.2	95/104	100/110	89/98	221/235	97/106	100/110	91/100	100/110	100/110	223/237	100/109	100/110	95/103	226/240	102/111	110/125	97/105	228/242	
			103B+103B	13.1/17.4	62.8/72.5	115/127	125/150	107/119	253/272	117/129	125/150	110/121	125/150	110/121	255/274	120/132	125/150	113/124	258/277	122/134	125/150	115/126	260/279	
			104B+104B	15.8/21.0	75.8/87.5	131/146	150/150	122/136	279/302	133/148	150/150	125/138	133/148	150/150	281/304	136/151	150/175	128/141	284/307	138/153	150/175	130/144	286/309	
			NONE	-	-	26	30	26	93	28	40	28	28	40	28	95	31	40	31	98	33	45	34	100
			102A	4.9/6.5	13.6/15.6	43/46	50/50	42/44	107/109	45/48	50/50	44/46	44/46	50/50	44/46	109/111	48/51	50/60	47/49	112/114	50/53	50/60	49/52	114/116
			103B	6.5/8.7	18.1/20.9	49/53	50/60	47/50	111/114	51/54	60/60	49/52	49/52	60/60	49/52	113/116	54/57	60/60	52/55	116/119	56/59	60/60	54/58	118/121
			105A	12.0/16.0	33.4/38.5	68/75	70/80	64/70	126/132	70/76	70/80	66/72	66/72	70/80	66/72	128/134	73/79	80/80	70/76	131/137	75/81	80/90	72/78	133/139
104B+104B	15.8/21.0	43.8/50.5	81/90	90/90	76/84	181/194	83/91	90/100	78/86	78/86	90/100	78/86	183/196	86/94	90/100	82/89	186/199	88/96	90/100	84/92	188/201			
208/230-3-60	MED	NONE	-	-	24/24	30/30	23/23	122	26/26	30/30	26/25	30/30	26/25	124	29/29	40/40	29/29	127	31/31	40/40	31/31	129		
		102A	4.9/6.5	13.6/15.6	41/43	50/50	39/41	136/138	43/45	50/50	41/43	50/50	41/43	138/140	46/48	50/50	45/46	141/143	48/50	50/50	47/49	143/145		
		103B	6.5/8.7	18.1/20.9	47/50	50/50	44/47	140/143	49/52	50/60	46/49	50/60	46/49	142/145	52/55	60/60	50/53	145/148	54/57	60/60	52/55	147/150		
		105A	12.0/16.0	33.4/38.5	66/72	70/80	62/67	155/161	68/74	70/80	64/69	70/80	64/69	157/163	71/77	80/80	67/73	160/166	73/79	80/80	69/75	162/168		
HIGH	208/230-1-60	NONE	-	-	27/27	40/40	27/27	158	29/29	40/40	29/29	40/40	29/29	160	32/32	45/45	33/32	163	34/34	45/45	35/35	165		
		102A	4.9/6.5	13.6/15.6	44/47	50/50	43/45	172/174	46/49	50/50	45/47	50/50	45/47	174/176	49/52	50/60	48/50	177/179	51/53	60/60	50/53	179/181		
		103B	6.5/8.7	18.1/20.9	50/53	50/60	48/51	176/179	52/55	60/60	50/53	60/60	50/53	178/181	55/58	60/60	53/56	181/184	57/60	60/60	56/59	183/186		
		105A	12.0/16.0	33.4/38.5	69/75	70/80	65/71	191/197	71/77	80/80	68/73	80/80	68/73	193/199	74/80	80/80	71/77	196/202	76/82	80/90	73/79	198/204		
104B+104B	15.8/21.0	43.8/50.5	82/90	90/90	77/85	246/259	84/92	90/100	80/87	90/100	80/87	248/261	87/95	90/100	83/91	251/264	89/97	90/100	85/93	253/266				

See "Legend and Notes for Table 10 on page 43.



Table 10 – Unit Wire/Fuse or HACR Breaker Sizing Data (cont)

UNIT	NO M. V.-Ph-HZ	IFM TYPE	ELEC. HTR			NO C.O. or UNPWR C.O.						w/ PWRD C.O.											
			CRHEATER**A00	Nom (kW)	FLA	NO PE.			w/ PE. (pwrd fr/unit)			NO PE.			w/ PE. (pwrd fr/unit)								
						MCA	MAX FUSE or HACR BRKR	DISC. SIZE FLA LRA	MCA	MAX FUSE or HACR BRKR	DISC. SIZE FLA LRA	MCA	MAX FUSE or HACR BRKR	DISC. SIZE FLA LRA	MCA	MAX FUSE or HACR BRKR	DISC. SIZE FLA LRA						
50KCA05	460-3-60	DD-STD	NONE	-	-	13	15	13	47	14	48	14	20	20	15	20	15	49	16	20	16	50	
			106A	6.0	7.2	21	25	21	54	22	22	55	23	25	23	23	25	23	56	25	25	25	57
			108A	11.5	13.8	29	30	29	61	30	30	62	31	35	31	35	31	35	63	33	35	32	64
			109A	14.0	16.8	32	35	32	64	33	33	65	35	40	35	40	35	40	66	37	40	36	67
			108A+108A	23.0	27.7	45	50	45	102	46	46	103	49	50	47	50	47	104	51	60	48	60	48
		MED	NONE	-	-	11	15	11	61	12	12	62	13	15	13	15	13	15	63	15	20	15	64
			106A	6.0	7.2	19	25	19	68	20	20	69	22	25	22	25	22	25	70	24	25	23	71
			108A	11.5	13.8	27	30	27	75	28	28	76	30	30	29	35	29	35	77	32	35	30	78
			109A	14.0	16.8	30	35	30	78	31	31	79	34	35	33	40	33	40	80	36	40	34	81
			108A+108A	23.0	27.7	43	50	43	116	44	44	117	47	50	45	50	45	118	49	50	46	50	46
HIGH	NONE	-	-	13	15	13	79	14	14	80	15	20	15	20	15	20	81	16	20	17	82		
	106A	6.0	7.2	21	25	21	86	22	22	87	24	25	24	25	24	25	88	25	25	25	89		
	108A	11.5	13.8	29	30	29	93	30	30	94	31	35	31	35	31	35	95	34	35	32	96		
	109A	14.0	16.8	32	35	32	96	33	33	97	35	40	35	40	35	40	98	37	40	36	99		
	108A+108A	23.0	27.7	45	50	45	134	46	46	135	49	50	47	50	47	136	51	60	48	60	48	137	
575-3-60	DD-STD	-	-	11	15	11	39	13	13	41	13	15	13	15	13	15	41	15	20	15	43		
	MED	-	-	8	15	8	42	10	10	44	11	15	10	15	10	15	44	12	15	12	46		
	HIGH	-	-	10	15	10	57	12	12	59	12	15	12	15	12	15	59	14	15	14	61		

See "Legend and Notes for Table 10 on page 43.

Table 10 – Unit Wire/Fuse or HACR Breaker Sizing Data (cont)

UNIT	NO M. V.-Ph-HZ	IFM TYPE	ELEC. HTR			NO C.O. or UNPWR C.O.						w/ PWRD C.O.												
			CRHEATER***A00	Nom (kW)	FLA	NO PE.			w/ PE. (pwrdr fr/unit)			NO PE.			w/ PE. (pwrdr fr/unit)									
						MCA	MAX FUSE or HACR BRKR	DISC. SIZE FLA LRA	MCA	MAX FUSE or HACR BRKR	DISC. SIZE FLA LRA	MCA	MAX FUSE or HACR BRKR	DISC. SIZE FLA LRA	MCA	MAX FUSE or HACR BRKR	DISC. SIZE FLA LRA							
50KCA06	208/230-1-60	DD-STD	NONE	-	-	39	60	37	163	41	60	40	40	165	44	60	43	168	46	60	45	170		
			102A	4.9/6.5	23.5/27.1	68/73	80/80	64/69	187/190	70/75	80/80	67/71	189/192	73/78	80/80	70/74	73/78	80/80	70/74	75/79	80/80	72/76	194/197	
			103B	6.9/8.7	31.4/36.3	79/84	80/90	73/79	194/199	80/86	80/100	76/81	196/201	83/89	90/100	79/85	89/91	90/100	79/85	199/204	85/91	100/100	81/87	201/206
			102A+102A	9.8/13.0	46.9/54.2	98/107	100/110	91/100	257/271	99/109	100/110	93/102	259/273	102/111	110/125	97/105	104/113	110/125	97/105	262/276	104/113	110/125	99/107	264/278
			103B+103B	13.1/17.4	62.8/72.5	117/130	125/150	110/121	299/308	119/131	125/150	112/123	291/310	122/134	125/150	115/126	124/136	125/150	115/126	294/313	124/136	125/150	117/128	296/315
			104B+104B	15.8/21.0	75.8/87.5	134/148	150/150	125/138	315/338	136/150	150/150	127/140	317/340	138/153	150/175	130/144	140/155	150/175	130/144	320/343	140/155	150/175	132/146	322/345
			NONE	-	-	29	40	28	120	31	45	31	45	31	122	34	45	34	125	36	50	36	50	127
			102A	4.9/6.5	13.6/15.6	46/49	50/60	44/46	134/136	48/51	60/60	46/49	136/138	51/53	60/60	50/52	53/55	60/60	50/52	139/141	53/55	60/60	52/54	141/143
			104B	7.9/10.5	21.9/25.3	57/61	60/70	54/58	142/145	58/63	60/70	56/60	144/147	61/66	60/70	59/63	63/67	70/70	59/63	147/150	63/67	70/70	61/65	149/152
			105A	12.0/16.0	33.4/38.5	71/77	80/80	67/73	153/159	73/79	80/80	68/75	155/161	76/82	80/80	72/78	78/84	80/80	72/78	158/164	78/84	80/80	75/80	160/166
104B+104B	15.8/21.0	43.8/50.5	84/92	90/100	79/86	208/221	86/94	90/100	81/89	210/223	89/97	90/100	84/92	91/99	100/100	84/92	213/226	91/99	100/100	86/94	215/228			
104B+105A	19.9/26.5	55.2/63.8	98/109	100/110	92/102	230/248	101/111	100/125	94/104	232/250	103/114	110/125	97/107	105/116	110/125	97/107	235/253	105/116	110/125	100/109	237/255			
208/230-3-60	MED	NONE	-	-	30/30	45/45	30/29	185	32/32	45/45	32/32	187	35/35	37/37	50/50	35/35	190	37/37	50/50	37/37	192			
		102A	4.9/6.5	13.6/15.6	47/50	50/60	45/47	199/201	49/51	60/60	47/50	201/203	52/54	60/60	51/53	60/60	51/53	204/206	54/56	60/60	53/55	206/208		
		104B	7.9/10.5	21.9/25.3	58/62	60/70	55/59	207/210	59/64	60/70	57/61	209/212	62/66	70/70	60/64	64/68	70/70	62/64	70/70	62/66	70/70	62/66	214/217	
		105A	12.0/16.0	33.4/38.5	72/78	80/80	68/74	218/224	74/80	80/80	70/76	220/226	77/83	80/80	73/79	79/85	80/80	73/79	223/229	79/85	80/80	76/81	225/231	
		104B+104B	15.8/21.0	43.8/50.5	85/93	90/100	80/88	273/286	87/95	90/100	82/90	275/288	90/98	90/100	85/93	92/100	100/100	85/93	278/291	92/100	100/100	88/95	280/293	
		104B+105A	19.9/26.5	55.2/63.8	99/110	100/110	93/103	295/313	101/112	110/125	95/105	297/315	104/115	110/125	99/108	106/116	110/125	99/108	300/318	106/116	110/125	101/111	302/320	
		NONE	-	-	30/30	45/45	30/29	185	32/32	45/45	32/32	45/45	32/32	187	35/35	37/37	50/50	35/35	190	37/37	50/50	37/37	192	
		102A	4.9/6.5	13.6/15.6	47/50	50/60	45/47	199/201	49/51	60/60	47/50	201/203	52/54	60/60	51/53	60/60	51/53	204/206	54/56	60/60	53/55	60/60	53/55	206/208
		104B	7.9/10.5	21.9/25.3	58/62	60/70	55/59	207/210	59/64	60/70	57/61	209/212	62/66	70/70	60/64	64/68	70/70	62/64	212/215	64/68	70/70	62/66	214/217	
		105A	12.0/16.0	33.4/38.5	72/78	80/80	68/74	218/224	74/80	80/80	70/76	220/226	77/83	80/80	73/79	79/85	80/80	73/79	223/229	79/85	80/80	76/81	225/231	
104B+104B	15.8/21.0	43.8/50.5	85/93	90/100	80/88	273/286	87/95	90/100	82/90	275/288	90/98	90/100	85/93	92/100	100/100	85/93	278/291	92/100	100/100	88/95	280/293			
104B+105A	19.9/26.5	55.2/63.8	99/110	100/110	93/103	295/313	101/112	110/125	95/105	297/315	104/115	110/125	99/108	106/116	110/125	99/108	300/318	106/116	110/125	101/111	302/320			
50KCA06	208/230-1-60	DD-STD	NONE	-	-	39	60	37	163	41	60	40	40	165	44	60	43	168	46	60	45	170		
			102A	4.9/6.5	23.5/27.1	68/73	80/80	64/69	187/190	70/75	80/80	67/71	189/192	73/78	80/80	70/74	73/78	80/80	70/74	75/79	80/80	72/76	194/197	
			103B	6.9/8.7	31.4/36.3	79/84	80/90	73/79	194/199	80/86	80/100	76/81	196/201	83/89	90/100	79/85	89/91	90/100	79/85	199/204	85/91	100/100	81/87	201/206
			102A+102A	9.8/13.0	46.9/54.2	98/107	100/110	91/100	257/271	99/109	100/110	93/102	259/273	102/111	110/125	97/105	104/113	110/125	97/105	262/276	104/113	110/125	99/107	264/278
			103B+103B	13.1/17.4	62.8/72.5	117/130	125/150	110/121	299/308	119/131	125/150	112/123	291/310	122/134	125/150	115/126	124/136	125/150	115/126	294/313	124/136	125/150	117/128	296/315
			104B+104B	15.8/21.0	75.8/87.5	134/148	150/150	125/138	315/338	136/150	150/150	127/140	317/340	138/153	150/175	130/144	140/155	150/175	130/144	320/343	140/155	150/175	132/146	322/345
			NONE	-	-	29	40	28	120	31	45	31	45	31	122	34	45	34	125	36	50	36	50	127
			102A	4.9/6.5	13.6/15.6	46/49	50/60	44/46	134/136	48/51	60/60	46/49	136/138	51/53	60/60	50/52	53/55	60/60	50/52	139/141	53/55	60/60	52/54	141/143
			104B	7.9/10.5	21.9/25.3	57/61	60/70	54/58	142/145	58/63	60/70	56/60	144/147	61/66	60/70	59/63	63/67	70/70	59/63	147/150	63/67	70/70	61/65	149/152
			105A	12.0/16.0	33.4/38.5	71/77	80/80	67/73	153/159	73/79	80/80	68/75	155/161	76/82	80/80	72/78	78/84	80/80	72/78	158/164	78/84	80/80	75/80	160/166
104B+104B	15.8/21.0	43.8/50.5	84/92	90/100	79/86	208/221	86/94	90/100	81/89	210/223	89/97	90/100	84/92	91/99	100/100	84/92	213/226	91/99	100/100	86/94	215/228			
104B+105A	19.9/26.5	55.2/63.8	98/109	100/110	92/102	230/248	101/111	100/125	94/104	232/250	103/114	110/125	97/107	105/116	110/125	97/107	235/253	105/116	110/125	100/109	237/255			

See "Legend and Notes for Table 10 on page 43.



Table 10 – Unit Wire/Fuse or HACR Breaker Sizing Data (cont)

UNIT	NO M. V-Ph-HZ	ELEC. HTR			NO C.O. or UNPWR C.O.						w/ PWRD C.O.											
		IFM TYPE	CRHEATER**A00	Nom (kW)	FLA	NO PE.			w/ PE. (pwrd fr/unit)			NO PE.			w/ PE. (pwrd fr/unit)							
						MCA	MAX FUSE or HACR BRKR	DISC. SIZE	FLA	LRA	MCA	MAX FUSE or HACR BRKR	DISC. SIZE	FLA	LRA	MCA	MAX FUSE or HACR BRKR	DISC. SIZE	FLA	LRA		
50KCA06	460-3-60	DD-STD	NONE	-	-	14	20	14	58	15	20	15	59	16	20	16	60	17	20	17	61	
			106A	6.0	7.2	23	25	22	65	23	25	23	24	66	24	25	24	67	26	30	26	68
			108A	11.5	13.8	31	35	29	72	31	35	31	32	73	32	35	32	74	34	35	33	75
			109A	14.0	16.8	35	35	33	75	34	40	34	36	76	35	40	35	77	38	40	37	78
			108A+108A	23.0	27.7	49	50	45	113	47	50	47	114	48	51	60	48	115	52	60	49	116
			108A+109A	25.5	30.7	52	60	49	119	50	60	50	53	120	55	60	51	121	56	60	53	122
			NONE	-	-	14	20	14	90	15	20	15	16	91	16	20	16	92	17	20	17	93
			106A	6.0	7.2	23	25	22	97	23	25	23	24	98	25	30	25	99	26	30	26	100
			108A	11.5	13.8	31	35	30	104	31	35	31	32	105	34	35	32	106	35	35	33	107
			109A	14.0	16.8	35	35	33	107	40	36	34	36	108	37	40	36	109	38	40	37	110
HIGH	460-3-60	DD-STD	108A+108A	23.0	27.7	49	50	46	145	47	50	47	146	51	60	48	147	52	60	49	148	
			108A+109A	25.5	30.7	53	60	49	151	50	60	50	152	55	60	52	153	56	60	53	154	
			NONE	-	-	14	20	14	90	15	20	15	91	16	20	16	92	17	20	17	93	
			106A	6.0	7.2	23	25	22	97	23	25	23	98	25	30	25	99	26	30	26	100	
575-3-60	575-3-60	DD-STD	108A	11.5	13.8	31	35	30	104	31	35	31	105	34	35	32	106	35	35	33	107	
			109A	14.0	16.8	35	35	33	107	34	40	34	108	37	40	36	109	38	40	37	110	
			108A+108A	23.0	27.7	49	50	46	145	47	50	47	146	51	60	48	147	52	60	49	148	
575-3-60	575-3-60	DD-STD	108A+109A	25.5	30.7	53	60	49	151	50	60	50	152	55	60	52	153	56	60	53	154	
			NONE	-	-	12	15	11	46	14	15	14	48	13	15	13	48	15	20	16	50	
			MED	-	-	10	15	10	64	12	15	12	66	12	15	12	66	14	15	14	68	
575-3-60	575-3-60	HIGH	NONE	-	-	10	15	10	64	12	15	12	66	12	15	12	66	14	15	14	68	
			NONE	-	-	10	15	10	64	12	15	12	66	12	15	12	66	14	15	14	68	

See Legend and Notes for Table 10 on page 43.

Legend and Notes for Table 10

LEGEND:

- BRKR – Circuit breaker
- CO – Convenient outlet
- DD – Direct drive (indoor fan motor)
- DISC – Disconnect
- FLA – Full load amps
- IFM – Indoor fan motor
- LRA – Locked rotor amps
- MCA – Minimum circuit amps
- MOCB – MAX FUSE or HACR Breaker
- PE – Power exhaust
- PWRD CO – Powered convenient outlet
- UNPWR CO – Unpowered convenient outlet

NOTES:

1. In compliance with NEC requirements for multimotor and combination load equipment (refer to NEC Articles 430 and 440), the overcurrent protective device for the unit shall be fuse or HACR breaker. Canadian units may be fuse or circuit breaker.

2. Unbalanced 3-Phase Supply Voltage

Never operate a motor where a phase imbalance in supply voltage is greater than 2%. Use the following formula to determine the percentage of voltage imbalance.

$$\% \text{ Voltage Imbalance} = 100 \times \frac{\text{max voltage deviation from average voltage}}{\text{average voltage}}$$

Example: Supply voltage is 230-3-60



- AB = 224 v
- BC = 231 v
- AC = 226 v

$$\begin{aligned} \text{Average Voltage} &= \frac{(224 + 231 + 226)}{3} = \frac{681}{3} \\ &= 227 \end{aligned}$$

Determine maximum deviation from average voltage.

(AB) $227 - 224 = 3 \text{ v}$

(BC) $231 - 227 = 4 \text{ v}$

(AC) $227 - 226 = 1 \text{ v}$

Maximum deviation is 4 v.

Determine percent of voltage imbalance.

$$\begin{aligned} \% \text{ Voltage Imbalance} &= 100 \times \frac{4}{227} \\ &= 1.76\% \end{aligned}$$

This amount of phase imbalance is satisfactory as it is below the maximum allowable 2%.

IMPORTANT: If the supply voltage phase imbalance is more than 2%, contact your local electric utility company immediately.

50KCC

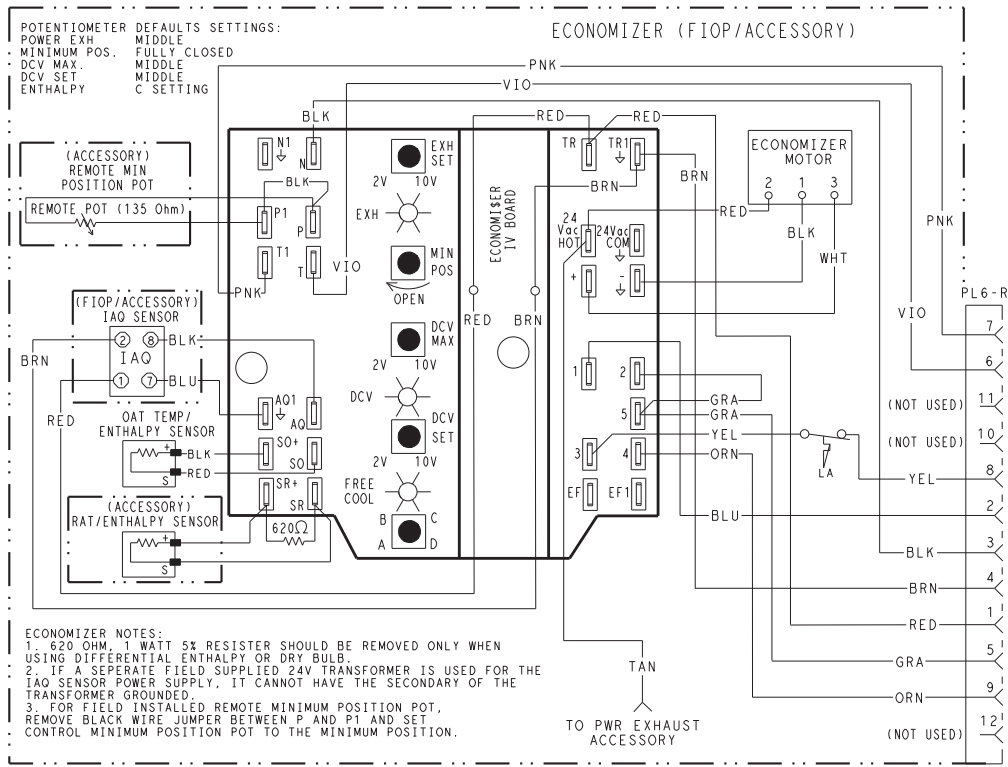

Fig. 66 - EconoMiSer IV Wiring

C09302

Step 12 — Adjust Factory-Installed Options

Smoke Detectors —

Smoke detector(s) will be connected at the Controls Connections Board, at terminals marked “Smoke Shutdown”. Cut jumper JMP 3 when ready to energize unit.

EconoMiSer IV Occupancy Switch —

Refer to Fig. 66 for general EconoMiSer IV wiring. External occupancy control is managed through a connection on the Controls Connections Board.

If external occupancy control is desired, connect a time clock or remotely controlled switch (closed for Occupied, open for Unoccupied sequence) at terminals marked OCCUPANCY. Cut jumper JMP 2 to complete the installation.

Step 13 — Install Accessories

Available accessories include:

- Curb
- Thru-base connection kit (must be installed before unit is set on curb)

- Electric heaters and single-point connection kits
- Manual outside air damper
- Two-Position motorized outside air damper
- EconoMiSer IV (with control)
- EconoMiSer2 (without control/for external signal)
- Power Exhaust
- Differential dry-bulb sensor (EconoMiSer IV)
- Outdoor enthalpy sensor
- Differential enthalpy sensor
- CO₂ sensor
- DDC interface (PremierLink)
- Louvered hail guard
- Motormaster head pressure controls
- Phase monitor control

Refer to separate installation instructions for information on installing these accessories.

Pre-Start and Start-Up —

This completes the mechanical installation of the unit. Refer to the unit’s Service Manual for detailed Pre-Start and Start-Up instructions. Download the latest versions from HVAC Partners (www.hvacpartners.com).

50KCG

UNIT START-UP CHECKLIST

(Remove and Store in Job File)

MODEL NO.: _____

SERIAL NO.: _____

I. PRE-START-UP

- VERIFY THAT ALL PACKAGING MATERIALS HAVE BEEN REMOVED FROM UNIT
- VERIFY INSTALLATION OF OUTDOOR AIR HOOD
- VERIFY INSTALLATION OF FLUE EXHAUST AND INLET HOOD
- VERIFY THAT CONDENSATE CONNECTION IS INSTALLED PER INSTRUCTIONS
- VERIFY THAT ALL ELECTRICAL CONNECTIONS AND TERMINALS ARE TIGHT
- CHECK THAT INDOOR-AIR FILTERS ARE CLEAN AND IN PLACE
- CHECK THAT OUTDOOR AIR INLET SCREENS ARE IN PLACE
- VERIFY THAT UNIT IS LEVEL
- CHECK FAN WHEELS AND PROPELLER FOR LOCATION IN HOUSING/ORIFICE AND VERIFY SETSCREW IS TIGHT
- VERIFY THAT FAN SHEAVES ARE ALIGNED AND BELTS ARE PROPERLY TENSIONED
- VERIFY THAT SCROLL COMPRESSORS ARE ROTATING IN THE CORRECT DIRECTION
- VERIFY INSTALLATION OF THERMOSTAT

II. START-UP

ELECTRICAL

SUPPLY VOLTAGE	L1-L2 _____	L2-L3 _____	L3-L1 _____
COMPRESSOR AMPS 1	L1 _____	L2 _____	L3 _____
COMPRESSOR AMPS 2	L1 _____	L2 _____	L3 _____
SUPPLY FAN AMPS	L1 _____	L2 _____	L3 _____

TEMPERATURES

OUTDOOR-AIR TEMPERATURE _____ °F DB (DRY BULB)

RETURN-AIR TEMPERATURE _____ °F DB _____ °F WB (WET BULB)

COOLING SUPPLY AIR TEMPERATURE _____ °F

PRESSURES

REFRIGERANT SUCTION	CIRCUIT A _____	PSIG
	CIRCUIT B _____	PSIG
REFRIGERANT DISCHARGE	CIRCUIT A _____	PSIG
	CIRCUIT B _____	PSIG

- VERIFY REFRIGERANT CHARGE USING CHARGING CHARTS

GENERAL

- ECONOMIZER MINIMUM VENT AND CHANGE-OVER SETTINGS TO JOB REQUIREMENTS (IF EQUIPPED)
- VERIFY SMOKE DETECTOR UNIT SHUTDOWN BY UTILIZING MAGNET TEST

50KCG

