

**CBS-3000A Series Coffee Brewers**

**Models:**

- ▶ **CBS-31A**
- ▶ **CBS-31Aap**
- ▶ **CBS-32A**
- ▶ **CBS-32Aap**



*Driven To Pioneer Innovation™*

**Table of Contents**

Contact Information .....	2	Service.....	8
Product Description/Features .....	2	Warranty.....	8
Technical Data.....	2	Principles of Operation.....	8
Brewing Specifications .....	2	Adjustments .....	9
Weights and Capacities .....	3	Brewer Parts .....	11
Electrical Configuration and Brewing Efficiency ...	3	CBS 31A & 32A .....	11
Dimensional Drawings & Utilities .....	4	Parts Drawing: CBS 31A & CBS 32A .....	13
Installation.....	5	Troubleshooting.....	14
Operating Procedures .....	7		

FETCO® is a trademark or trade name of Food Equipment Technologies Company.

# Contact Information

**FETCO®**  
Food Equipment Technologies Company  
600 Rose Road  
Lake Zurich • IL • 60047-0429 • USA

**Phone:** (800) 338-2699 (US & Canada)  
(847) 719-3000  
**Fax:** (847) 719-3001

**Email:** sales@fetco.com  
techsupport@fetco.com

**Internet:** www.fetco.com

---

## Product Description/Features

**CBS-31A - Single Coffee Brewing System**  
**CBS-32A - Twin Coffee Brewing System**



Used with 2.5 liter gravity pots

**CBS-31Aap - Single Coffee Brewing System**  
**CBS-32Aap - Twin Coffee Brewing System**



Used with various size airpots

- Compact design
- All stainless steel brewer body construction
- Hot water spigot
- Mercury type power relay
- Electronic temperature control
- “Ready to brew” indicator lamp
- Non clog sprayhead
- Heater protection control

**Optional Features:**

- Half batch brewing capability\*
- Iced tea brewing capability\*
- Color stainless steel finish
- Custom and export voltage

\* Can be added at any time.

**Note:** Throughout this manual, all references to CBS-31 and CBS-32 brewers apply to both the “A” and “Aap” versions, unless otherwise indicated.

---

## Technical Data

### Brewing Specifications

**Brew Volume: CBS-31A & 32A**

Full Batch 2.5 liters  
Half Batch 1.25 liters

**CBS-31Aap & 32Aap**

2.2 liters / 3.0 liters  
1.1 liters / 1.5 liters

**Brew Time: CBS-31A & 32A**

Full Batch 3½ - 4 min.  
Half Batch 1¾ - 2 min.

**CBS-31Aap & 32Aap**

3-3½ min. / 4-4½ min.  
1½-1¾ min. / 2-2¼ min.

*(Allow an extra 1-3 minutes for coffee to finish dripping)*

**Coffee Filters:** Plastic Brew Basket: 9¾” X 4½” FETCO # F003  
Stainless Steel Brew Basket: 13” X 5” FETCO # [F002](#)

**Temperature:**

203°F inside water tank (at sea level)  
195°F ± 5° at sprayhead

**Water Requirements:** 20-75 psig  
¼ gpm (CBS-31), ½ gpm (CBS-32)

---

\*FETCO currently supplies 2.2 and 3.0 liter airpots. Aap brewers can also be configured for the other available sizes, 1.9 and 2.5 liters.

## Weights and Capacities

Brewer Model	Weight (empty)	Water tank Capacity & Weight		Weight (filled)	Dispenser Weight, ea.	Dispenser. Filled, ea.	Total Weight Brewer & Dispensers, filled
CBS-31A	24 lbs.	1.8 gal.	15.0 lbs.	39.0 lbs.	4 lbs.	9.5 lbs. (2.5 L)	48.5 lbs.
CBS-31Aap	23 lbs.	1.7 gal.	14.1 lbs.	37.1 lbs.	4 lbs.	10.6 lbs. (3.0 L)	47.7 lbs.
CBS-32A	36 lbs.	4.9 gal.	40.7 lbs.	76.7 lbs.	4 lbs.	9.5 lbs. (2.5 L)	95.7 lbs.
CBS-32Aap	35 lbs.	4.6 gal.	38.2 lbs.	73.2 lbs.	4 lbs.	10.6 lbs. (3.0 L)	94.4 lbs.

## Electrical Configuration and Brewing Efficiency

Model	Heater Configuration	Voltage Connection	Phase	Wires	KW	Max. Amp draw	Brews per Hour (cold or hot water)					
							2.2 lit. (max 13)		2.5 lit. (max 12)		3.0 lit. (max 11)	
							cold	hot	cold	hot	cold	hot
CBS-31A/Aap (-1)	1 X 1300 w	120	1 ph.	2 + grnd.	1.4	11.3	5.5	12.8	4.9	11.3	4.1	9.4
CBS-31A/Aap (-2)	1 X 1800 w	120	1 ph.	2 + grnd.	1.9	15.4	7.7	13.0	6.8	12.0	5.6	11.0
CBS-31A/Aap (-3)	1 X 2300w	120/208	1 ph.	3 + grnd.	1.8	8.7	7.4	13.0	6.5	12.0	5.4	11.0
		120/220	1 ph.	3 + grnd.	2.0	9.2	8.5	13.0	7.5	12.0	6.3	11.0
		120/240	1 ph.	3 + grnd.	2.4	10.0	9.8	13.0	8.6	12.0	7.2	11.0
CBS-32A/Aap (-1)	1 X 1800w	120	1 ph.	2 + grnd.	1.9	15.7	7.7	17.7	6.8	15.6	5.6	13.0
CBS-32A/Aap (-2)	2 X 2300w	120/208	1 ph.	3 + grnd.	3.5	17.3	14.7	27.0	13.0	24.0	10.8	22.0
		120/220	1 ph.	3 + grnd.	3.9	18.2	17.1	27.0	15.0	24.0	12.5	22.0
		120/240	1 ph.	3 + grnd.	4.7	19.8	19.6	27.0	17.3	24.0	14.4	22.0

# Dimensional Drawings & Utilities

## CBS-31A

Electrical input and water connection in rear

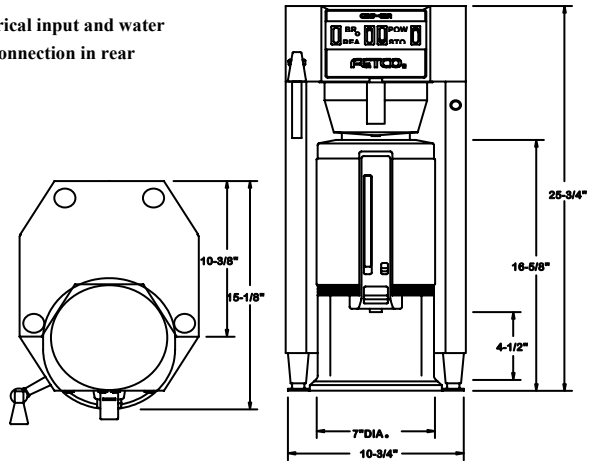

Water Requirements: 20-75 psig, 1/4 gpm flow rate. Water inlet is 1/4" male flare

## CBS-32A

Electrical input and water connection in rear

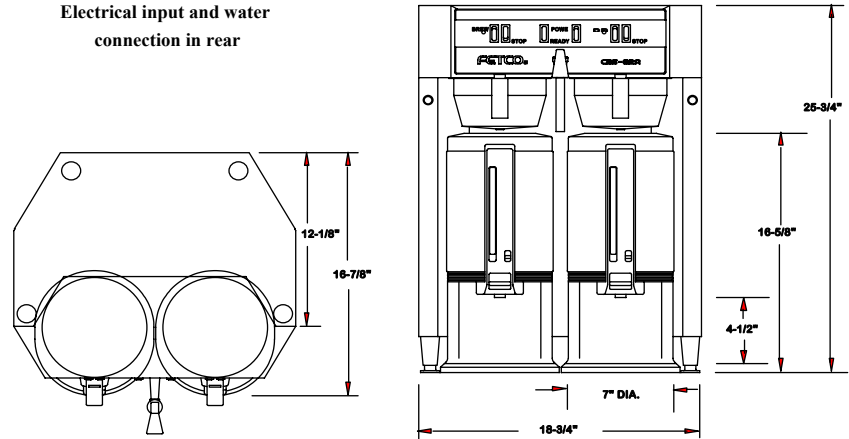

Water Requirements: 20-75 psig, 1/2 gpm flow rate. Water inlet is 1/4" male flare

## CBS-31Aap

Electrical input and water connection in rear

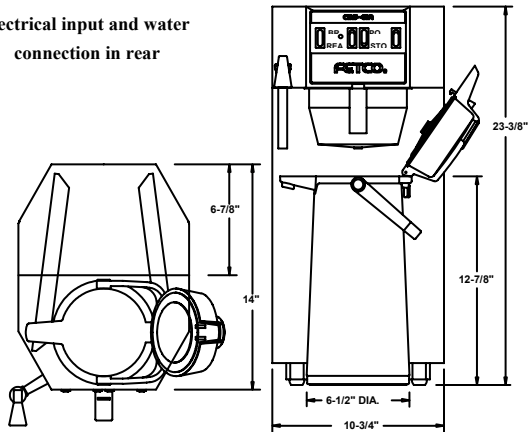

Water Requirements: 20-75 psig, 1/4 gpm flow rate. Water inlet is 1/4" male flare

## CBS32Aap

Electrical input and water connection in rear

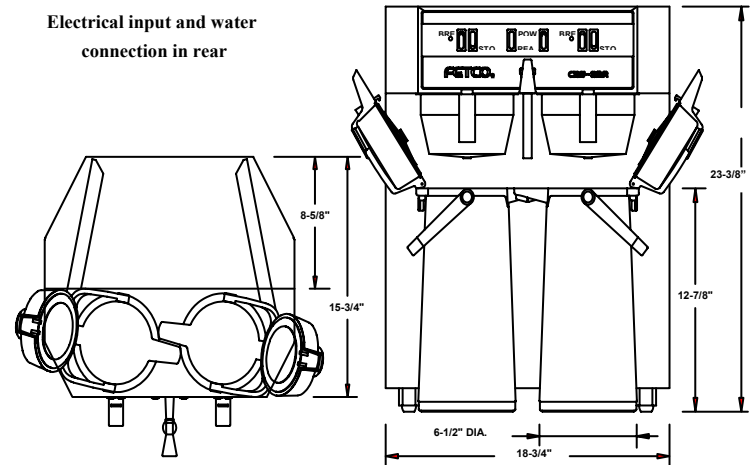

Water Requirements: 20-75 psig, 1/2 gpm flow rate. Water inlet is 1/4" male flare

# Installation

(For Qualified Service Technicians Only)

## Keys To A Successful Installation

If not installed correctly by qualified personnel, the brewer may not operate properly and damage may result. Damage resulting from improper installation are not covered by the warranty.

Here are the key points to consider before installation:

### Electrical:

- ❖ All FETCO brewers require **NEUTRAL**. Ground is not an acceptable substitute. Installation without neutral may cause damage to the electronic components.
- ❖ The electronic controls require at least 105 volts. Less than 105 volts will cause erratic behavior from the brewer. On 120/208-240 volt models, the #2 terminal on the terminal block provides power to the controls.
- ❖ The circuit breaker is located on the back of the brewer. To reset it, press and release the white button.
- ❖ The electrical drawing for the brewer is located on the inside of the lower cover.

### Plumbing:

- ❖ This equipment is to be installed in compliance with the applicable federal, state, or local plumbing codes.
- ❖ The water line must be flushed thoroughly prior to connecting it to the brewer to prevent debris from contaminating the machine.
- ❖ Verify that the water line will provide at least ¼ gallon per minute for the CBS-31, and ½ gallon per minute for the CBS-32 before connecting it to the brewer.

### General:

- ❖ Use only qualified beverage equipment service technicians for installation. A Service Company Directory may be found on our web site, <http://www.fetco.com>.

## Installation Instructions

### Brewer Setup

1. Review the dimensions for the unit you are installing. Verify that the brewer will fit in the space intended for it, and that the counter or table will support the total weight of the brewer and dispensers when filled.
2. "Aap" model brewers are shipped with the legs attached. These legs are factory adjusted to one of two settings. One setting is for the 2.2 liter air pot (narrow).\* The other setting is for the 3.0 liter air pot (wide).\* The legs for the "A" model brewers are packed inside the brew basket, and must be attached by the installer. Place the brewer on its back and screw in the legs.
3. Place the brewer on the counter or stand.
4. When the brewer is in position, level it front to back as well as side to side by adjusting the legs.
5. Remove the lower cover to access the water and electrical connections. Knock-outs are provided in the back and base of the brewer body for the connections.

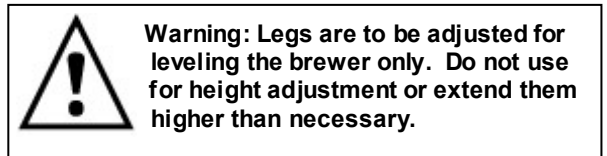

*\*Adjusting leg settings: Two holes are provided to adjust the width of the leg rails. Remove the ¼-20 allen head bolt with a 3/16 allen wrench and move rail to line up with desired hole. Fasten ¼-20 allen bolt. Repeat process on other side.*

### Water Connection

1. Water inlet is a 1/4 inch male flare fitting.
2. The brewer can be connected to a cold or hot water line. Cold water is preferred for best coffee flavor, but hot water will allow for faster recovery times.
3. Install a water shut off valve near the brewer to facilitate service. If an in-line water filter is used, it should be installed after the water shut off valve, and in a position to facilitate filter replacement.
4. Flush the water supply line and filter **before** connecting it to the brewer.
5. Verify that the water line will provide at least ¼ gallon per minute for the CBS-31, and ½ gallon per minute for the CBS-32, and that the water pressure is between 20 and 75 psig.
6. Use a wrench on the factory fitting when connecting the incoming water line. This will reduce stress on the internal connections and reduce the possibility of leaks developing after the installation has been completed.

## Electrical Connection

1. Verify that the actual voltage at the electrical service connection is compatible with the specifications on the brewer's serial number label. Make sure the electrical service includes **neutral**.
2. The temperature and water tank fill level are pre-set at the factory. There is no need to turn off the heaters during the installation process. The heaters are disabled by the control board until the tank is full of water. The heating process will start automatically when the tank has filled.
3. Only 120vac powered units are shipped from the factory with power cords and plugs attached. For other voltages, a terminal block is provided for connecting the incoming power wires. Consult local codes to determine if a cord and plug can be installed, or if the unit must be hard wired.
4. A fused disconnect switch or circuit breaker on the incoming power line must be conveniently located near the brewer, and its location and markings known to the operators.
5. The body of the brewer must be grounded to a suitable building ground. A ground lug is provided in the brewer next to the power terminal block. Use only 10 gauge copper wire for grounding.
6. Electrical connections must be secured in-place within the unit to meet national and local standards.

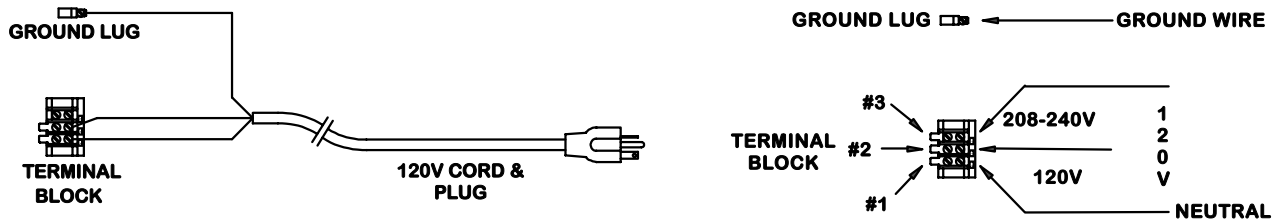
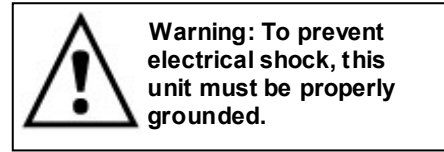

### Electrical Configurations – U.S. & Canada

7. Finally, connect the incoming power wires to the terminal block in accordance with applicable codes.

## Final Setup

1. Turn on the incoming water supply line and inspect both inside and outside of the brewer for leaks in all fittings and tubes
2. Turn on the incoming power.
3. Turn on the brewer's main power switch.
4. Within 6 seconds, the hot water tank will begin filling until the water is sensed by the probe at the top of the tank.
5. The heaters will be disabled by the control board until the tank is full.
6. The brewer will be ready for operation as soon as the ready light comes on to signify that the water tank is up to temperature. The time required to reach brewing temperature will vary according to the electrical configuration ordered.
7. Review the Operating Instructions. Brew one full batch (water only) on each side to confirm proper fill levels. The brewer is factory set with water only (no coffee) to dispense the correct amount of water.
8. Re-attach the covers after one final inspection for leaks. Look closely in the top of the brewer at the dispense fittings during this inspection.

## Operator Training

Review the operating procedures with whoever will be using the brewer. Pay particular attention to the following areas:

1. Always pre-heat the dispensers before the first use of each day by filling them half way with hot water, and letting them stand for at least 15 minutes.
2. Don't remove the brew basket until it has stopped dripping.
3. Make sure the dispenser is empty before brewing into it.
4. Show how to attach covers, close, and or secure the thermal dispensers for transporting.
5. Show the location and operation of the water shut off valve as well as the circuit breaker for the brewer.
6. Steam from the tank will form condensation in the vent tubes. This condensation will drip into and then out of the brew baskets. 1/4 cup discharging overnight is possible. Place an appropriate container under each brew basket when not in use.
7. We recommend leaving the power to the brewer on overnight. The water tank is well insulated and will use very little electricity to keep the tank hot. Leaving the brewer in the on position will also avoid delays at the beginning of shifts for the brewer to reach operating temperature.

# Operating Procedures

## 1. Turn the power switch (A) to the on position

- The power switch will illuminate to indicate that the brewer has power and is operating.
- When the **ready light (B)** illuminates, the brewer is fully up to temperature. The amount of time required to gain full operating temperature will vary depending on the electrical configuration that was ordered, and the temperature of the incoming water.

## 2. Prepare the brew baskets (F).

- Place a paper filter in each basket to be used. Pour the appropriate amount of pre-measured, ground coffee into the filter. The amount of coffee used will depend on your personal tastes and the recommendation of your roaster.
- Slide the brew basket back into the rails on the brewer.
- Select full or half batch mode (C) (optional).

## 3. Prepare the dispenser(s).

- Ensure that the dispensers are empty. If you are using airpots, open the cover and remove the pump stem before brewing.
- Place the dispensers in position under the brew baskets.

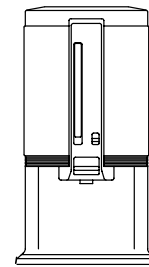

Gravity pot

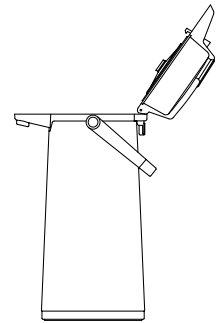

Airpot

## 4. Press the brew switch (D) to start the brew cycle.

- The brew light (E) will illuminate, verifying that the brew cycle has begun.
- It is normal for the ready light to go out after the start of the brew cycle. On twin brewers, there is enough hot water in the brewer to support a second brew, even if the ready light is off. After brewing on both sides, you must wait for the ready light to come back on.
- The electrical configuration and the electrical power connected to the brewer will determine how long before the ready light comes back on for the next brew.
- If it is necessary to interrupt the brew cycle before it is finished, press the stop switch (G).

## 5. You now have a dispenser of freshly brewed coffee, ready to serve, that will taste fresh and stay hot. ONLY a non-heated dispenser can do that.

- If you are using airpots, insert the pump stem before closing the cover.



### CAUTION:

Do not remove the brew basket immediately after the brew cycle has finished. Wait until dripping from the bottom of the brew basket has stopped. Carefully remove the brew basket while inspecting the inside of the basket for hot coffee that has not finished draining.

Legend:	
<b>A</b>	Power switch
<b>B</b>	Ready light
<b>C</b>	Full/half batch switch
<b>D</b>	Brew switch
<b>E</b>	Brew light
<b>F</b>	Brew basket
<b>G</b>	Stop switch
<b>H</b>	Hot water faucet

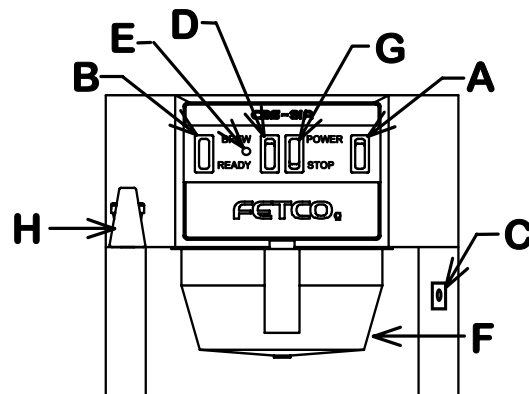

# Service

## Warranty

All FETCO brewers come with a limited warranty. All warranty service must be pre-authorized by calling the FETCO Service Department at (800) 338-2699.

## Principles of Operation

### Fill System

The fill system consists of a liquid level control board, a water level probe at the top of the tank, and a fill valve. As the water rises and touches the probe, continuity is established between the probe tip and the tank body, and the fill valve closes.

When water is dispensed, the water level drops below the probe. After a 5 second delay, the fill valve opens until the water touches the probe again. The 5 second delay, and the speed that water refills the tank during brewing, results in many short bursts of water. The sound made by these repetitive bursts will let you know the fill system is functioning normally. (This sound may not be audible in a noisy environment.)

The fill system is designed to protect the heaters during both the installation and a loss of the water supply. During initial installation, or whenever the power switch is turned on, voltage will not be supplied to the thermostat until the tank fills and water touches the water level probe. During operation, when water is dispensed and the water level drops below the probe, a fill signal is sent to the fill valve. If no water is sensed by the probe after 40 seconds, the voltage to the thermostat and the heaters is removed.

Water enters the tank near the bottom. This introduces cold incoming water directly to the heaters and away from the dispense assembly.

The water tank can be drained through a valve located on the back of the brewer, near the incoming water connection.

### Temperature System:

The temperature system consists of an electronic thermostat, a temperature probe, and heating elements, and is enabled by the liquid level control board. (See the previous section - Fill System.)

When the water level probe is in contact with water, power is delivered to the thermostat through the liquid level control board. If the temperature probe senses that the water is not hot enough, the thermostat energizes the heating elements through the mercury relay, the water is heated, and the ready light goes off.

Once the water temperature reaches the set point, the thermostat disengages power to the heaters and the ready light illuminates. The thermostat is adjusted to  $203^{\circ}\text{F} \pm 2^{\circ}$  at the factory. (Slightly lower for high altitude installations.)

### Timing & Dispense System:

The timing system consist of the timer, the dispense valve, the brew start switch, and the brew stop switch. When the brew start switch is pressed, the timer starts its' cycle. The timer energizes the dispense valve, which opens and allows water to flow into the brew basket. It also lights the brew light. The valve remains energized throughout the brew cycle timed sequence.

When the timer finishes its cycle, it removes voltage from the dispense valve. The valve closes, the flow of water stops, and the brew light goes out.

The brew stop switch is used only when it is necessary to interrupt the brew cycle before the cycle is finished.

The timer used with the half batch option has a small jumper wire on one end. A switch can replace this jumper to open or close this connection. Opening this connection cuts the timed output in half.

## Adjustments

### Thermostat Adjustment:

#### **For equipment manufactured before April 2004**

The brewer's water tank temperature is factory set at 203°F (slightly lower for high altitudes, to prevent boiling). This setting will deliver water at 195°F ± 5° to the coffee grounds.

Measure the temperature by holding a thermometer in the stream of water flowing out of the hot water faucet. The temperature should be 195°F ± 5°.

If an adjustment is necessary:

- Remove the upper cover of the unit.
- The thermostat is located in the upper section of the brewer. Locate the adjustment stem, which may be taped to the thermostat.
- Insert the stem into the adjustment hole.
- Turn the adjustment stem slightly counterclockwise (as viewed from the stem insertion point) to increase the temperature, and clockwise to decrease the temperature.
- If you decreased the temperature setting, run 2 or 3 brew cycles to allow enough cold water into the brewer to lower the tank temperature.
- Wait for the "ready" light to come on, and measure the temperature again.
- Repeat until the desired temperature is obtained.
- Replace the cover(s).

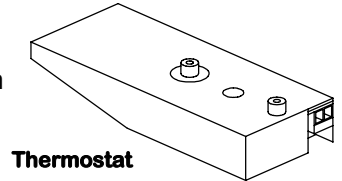

#### **Effective April 2004:**

A new digital thermostat and temperature probe were introduced as a direct replacement for the old style thermostat and probe.

During normal operation, the digital readout displays the last two digits of the actual water temperature. When the adjustment knob is turned, the readout begins flashing to indicate the set point, not the actual temperature. After the knob is released, the readout stops flashing and displays the actual temperature again.

A red LED lights when the power to the thermostat is on. A yellow LED lights when the thermostat is calling for heat.

To adjust, turn the adjustment knob. The display will flash, indicating that the display is showing the set point, not the actual temperature.

The display shows only the last 2 digits of the temperature.

The dots below the numbers indicate the temp range.

- 0 dots – less than 100° F
- 1 dot – between 100° and 200° F
- 2 dots – over 200° F

Examples:

7 5 = 75°F

8 7. = 187°F

0. 3. = 203°F

## Timer Adjustment:

### For equipment manufactured before April 2004

The timers control the amount of water that is used for brewing. The dual sided brewer, (CBS-32A, & 32Aap) has separate timers to control each side independently.

All timers are factory set to deliver the correct amount of water.

There are three possible types of timers used:

- Part # 51006 – full batch only (standard)
- Part # 51005 – full / half batch (optional) The half batch setting provides exactly half the amount of water as the full batch setting.
- Part # 51017 – dual portion (optional) The timer has 2 independent settings.

Adjustment of the factory settings may be desired to compensate for the amount of water absorbed by the coffee grounds. Approximately 2 ounces of water will be absorbed for every ounce of coffee.

To adjust the timer:

- Remove the brewer's upper cover.
- If your brewer has the half-batch or dual portion option, make sure the selector switch is in the full batch position.
- Note the current setting of the dial before making any adjustments.
- Turn the knob clockwise to increase and counter-clockwise to decrease the timer setting. On the dual portion timer, the knob labeled "T1" controls the full batch setting.
- Run a full brew cycle to check the brew level.
- If necessary, repeat the adjustment until the desired volume is obtained.
- For the dual portion timer, set the selector switch on "half" and adjust the knob labeled "T2" until the desired volume of water is obtained.
- Replace the cover.

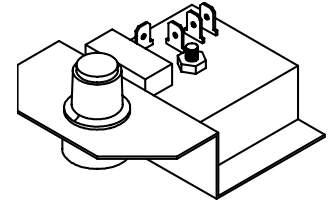

# 51006 timer, 120V

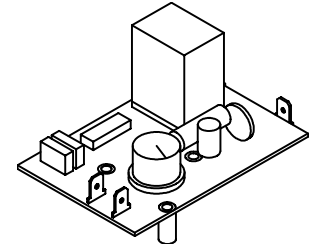

#51005 timer, full/half, 120V

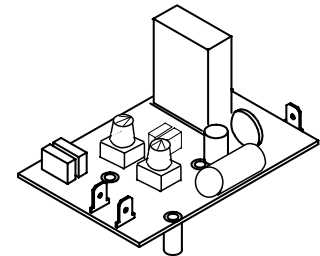

#51017 timer, dual portion, 120V

### Effective April 2004:

A new digital timer was introduced as a direct replacement for the three old style timers. When a batch selector switch is not connected, the timer functions as a single portion timer.

The timer has two independent settings, with three dials for each setting. The first dial in each group sets 100 second increments, the second dial sets 10 second increments, and the third dial sets 1 second increments.

A red LED lights when the power to the timer is on. A yellow LED lights when the timer is running.

A small flat head screwdriver is required to adjust the dials.

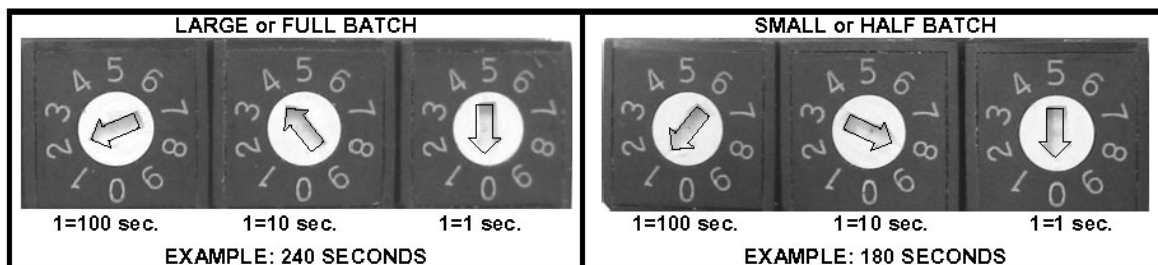

part # K034, digital timer, 100-120 VAC

part # K036, digital timer, 200-240 VAC (export versions only)

# Brewer Parts

## CBS 31A & 32A

Part #	Description	#	Used on	
52003	Ground lug terminal MEDIUM size	0	31a	32a
1010	Brewer Body Weldment	1		32a
1005	Brewer Body Weldment	1	31a	
73007	Legs, 2.5" adjustable	2	31a	32a
23035	Brew basket, black plastic (9-3/4 x 4-1/2 filters)	3	31a	32a
23036	Brew basket, brown plastic ,tea (9-3/4" x 4-1/2" filters)	3	31a	32a
101098	Brew basket assy, stainless steel, (13" X 5" filters)	3	31a	32a
9010	Brew basket wire insert, 13" X 5"	3	31a	32a
71003	Faucet Seat cup, HOT water faucet	5	31a	32a
71039	Faucet, upper assy.	5	31a	32a
102031	Faucet assy. hot water	5	31a	32a
K034	Digital Timer Kit, 100-120VAC	6	31a	32a
K036	Digital Timer Kit, 200-240VAC (EXPORT)	6	31a	32a
58018	Lamp, "brew" indicator 220vac (export)	8	31a	32a
58017	Lamp, "brew" indicator 120vac	8	31a	32a
58064	Lamp, "ready" indicator, green 120VAC	9	31a	32a
58019	Lamp, "ready" indicator, green 220VAC (export)	9	31a	32a
58061	Switch, brew start rocker, momentary 240vac	10	31a	32a
58062	Switch, brew stop rocker, momentary 240vac	11	31a	32a
58063	Switch, power rocker, red, 120vac	12	31a	32a
58024	Switch, full/half batch selector, w/harness (optional)	13	31a	32a
108034	Liquid Level Control Brd. 100-120VAC, 50-100K ohm	14	31a	32a
108035	Liquid Level Control Brd. 200-240VAC, 50-100K ohm (EXPORT)	14	31a	32a
K033	Digital thermostat, 100-120VAC	15	31a	32a
K035	Digital thermostat, 200-240VAC (EXPORT)	15	31a	32a
3076	Mounting bracket (Thermostat)	16	31a	32a
52016	Relay mercury 20amp DP 120vac	17	31a	32a
52015	Relay mercury 20amp SP 120vac (120v brewer)	17	31a	32a
52021	Relay mercury 20amp SP (export 208-240vac coil)	17	31a	32a
52032	Relay mercury 20amp DP (export 208-240v coil)	17	31a	32a
52023	Terminal block w/ marking label	18	31a	32a
102035	Cord 16amp w/European plug assy.	19	31a	32a
102049	Cord 15amp w/British plug assy.	19	31a	32a
102050	Cord 15amp w/Australian plug assy.	19	31a	32a
102033	Cord, 120vac 20amp w/5-20p NEMA plug assy.	19	31a	32a
102032	Cord, 120vac 15amp w/5-15p NEMA plug assy.	19	31a	32a
1152	Brewer Back cover	20	31a	
2045	Brewer Back Cover Weldment	20		32a
52020	Circuit Breaker 5 amp	21	31a	32a
3074	Fill Valve Mounting plate S-53	22	31a	32a
57017	Fill Valve assy., 240vac plastic (S-53 export)	22	31a	32a
31078	Fill Valve Fitting 3/8" FPT (inner) (S-53)	22	31a	32a
57006	Fill Valve assy., 120v plastic (S-53)	22	31a	32a
24012	Fill Valve Gasket	22	31a	32a
31096	Fill Valve Fitting 3/8" MPT x 1/4" flare elbow (inlet)	23	31a	32a
4010	Tank Weldment	24		32a
4009	Tank Weldment	24	31a	
83007	Gasket, 7/8 o.d. x 9/16" I.d. (heater)	25	31a	32a
82019	Heater Screw, 10-32 x 1/4" ss (heater connection)	25	31a	32a
107006	Heater element 1300w 120v bottom mount	25	31a	32a
107001	Heater element 2300w 240v bottom mount	25	31a	32a
84005	Locknut, 9/16-18 (heater)	25	31a	32a
107007	Heater element 1800w 120v bottom mount	25	31a	32a
83008	Gasket, 1-1/16 o.d. x 9/16" I.d. (heater)	25	31a	32a
31009	Locknut 3/8" NPSL	26	31a	32a
31009	Locknut 3/8" NPSL (2 ea. for dispense & water inlet)	27	31a	32a

Aap brewers use the same parts, except for the tank, body, and legs. Call Tech. Support At (800) 338-2699 for assistance with these items.

Part #	Description	#	Used on
25005	Silicone Tubing 5/8 x 3/8 x 7 1/2"	29	31a
24010	Spray cutter FLOW DISK O Ring Seal	30	31a 32a
23104	spray cutter, clear plastic, 6+1	31	31a 32a
102043	Spray cutter FLOW DISK assy. (plastic)	32	31a 32a
57015	Valve, dispense, Coil 220vac (export)	33	31a 32a
102044	Dispense valve assy. 120vac	33	31a 32a
102045	Dispense valve assy. 220vac (export)	33	31a 32a
57016	Valve, dispense, Repair kit	33	31a 32a
3097	Mounting bracket (Disp. valve)	34	31a 32a
25006	Silicone Tubing 5/8 x 3/8 x 3"	35	31a 32a
25018	Silicone Tubing 5/8 x 3/8 x 4 3/4"	35	32a
31071	Fitting tank dispense 1/2" barb x 3/8" MPT	36	31a 32a
31009	Locknut 3/8" NPSL (2 ea. for dispense & water inlet)	37	31a 32a
31009	Tank Fitting Locknut 3/8" NPSL (2 for disp & water inlet)	38	31a 32a
31009	Locknut 3/8" NPSL (2 ea. for dispense & water inlet)	39	31a 32a
31009	Locknut 3/8" NPSL (2 ea. for dispense & water inlet)	40	31a 32a
31073	Tank Fitting 3/8" MPT x 3/8" hose barb (hot water tank out)	41	31a 32a
25007	Silicone Tubing 5/8 x 3/8 x 6 3/4"	42	31a 32a
31075	Faucet Fitting (hot water faucet mount) flare	43	31a 32a
101082	Thermos 2.2 liter w/brew-thru lid assy.	44	31a 32a
101057	Thermos 2.2 liter w/regular lid assy.	44	31a 32a
101076	Thermos lid regular (closed type)	45	31a 32a
101077	Cover assy. Brew-thru	46	31a 32a
1157	Upper Cover	47	32a
1153	Top (upper) Cover	47	31a
25008	Silicone Tubing 5/16 x 3/16 x 2 1/4"	48	31a 32a
25010	Silicone Tubing 5/16 x 3/16 x 3 1/2"	49	31a 32a
25019	Silicone Tubing (rht side only) 5/16 x 3/16 x 5"	49	32a
29027	Plastic T Connector	50	31a 32a
25020	Silicone Tubing 5/16 x 3/16 x 4 1/2"	51	32a
25009	Silicone Tubing 5/16 x 3/16 x 2 1/2"	51	31a 32a
31072	Fitting 1/4" hose barb x 1/8" MPT	52	31a 32a
31006	By-pass & misc. Locknut 1/8" NPT	53	31a 32a
24002	Tank Cover Gasket	54	31a 32a
102013	Tank Cover assy.	55	31a 32a
21026	Water Level Probe Housing	56	31a 32a
2010	Water Level Probe Weldment	57	31a 32a
25004	Thermostat Temp probe Lead Cover (tubing)	58	32a
102213	Digital temp probe assy., 12" (use with K033 digital thermostat only)	58	31a 32a
53026	thermostat temp probe 12" (use with K033 digital thermostat or 53012 thermostat)	58	31a 32a
31036	Thermostat Temp probe tank Fitting 1/4" MPT x 1/4" comp.	59	31a 32a
31037	Thermostat Temp probe Locknut 1/4" NSPL (temp. probe tank fitting)	60	31a 32a
45027	Nameplate	61	32a
45025	Nameplate	61	31a
31006	Locknut 1/8" NPT (1 on vent & 2 on bypass valve)	62	31a 32a
83005	By-pass & misc. Washer	63	31a 32a
31070	Fitting (by pass & tank drain outlet)	64	31a 32a
25023	Silicone Tubing (drain) 1/2 x 1/4 x 6 1/2"	65	31a 32a
31087	Fitting 5/16" hose I.D. x 1/8" FPT (drain valve)	66	31a 32a
31086	Drain cock 1/8" MPT	67	31a 32a

Aap brewers use the same parts, except for the tank, body, and legs. Call Tech. Support At (800) 338-2699 for assistance with these items

**Parts Drawing: CBS 31A & CBS 32A**

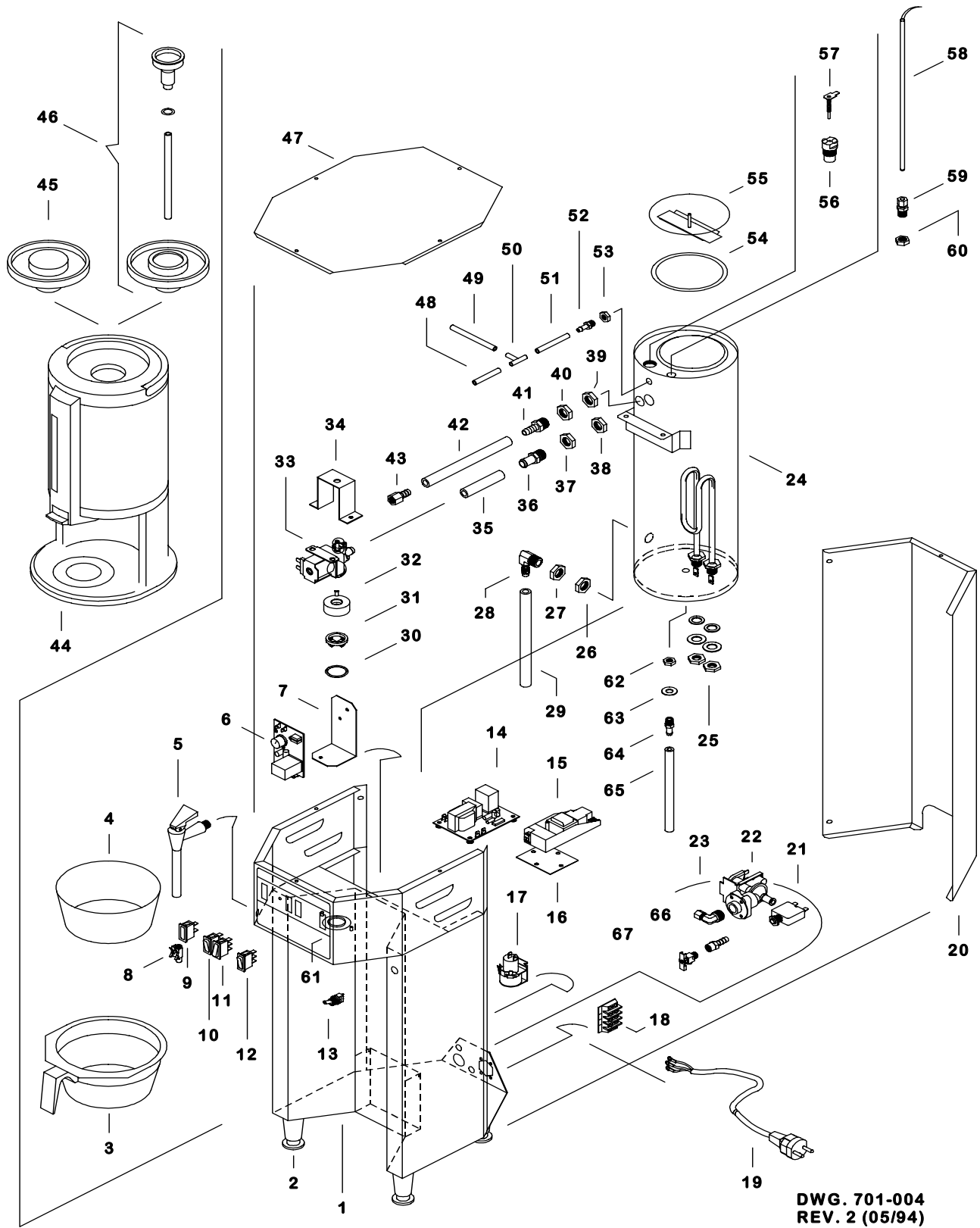

**DWG. 701-004  
REV. 2 (05/94)**

Aap brewers use the same parts, except for the tank, body, and legs. Call Tech. Support At (800) 338-2699 for assistance with these items

# Troubleshooting

Brewing Problem	Possible Cause	Solution
<b>Brew switch</b> will not start brew cycle (no water is dispensed) <i>and</i> brew light <b>does not</b> come on, even when switch is pressed in.	No power to the brewer (Brewer lights are not illuminated)	-Make sure power switch is on -Check power connection. (plug or hard wire connection) -Check the wall circuit breaker / reset -Reset the circuit breaker, located on the back of the brewer. Press and release the white button.
	Bad brew switch	-Replace switch.
<i>and</i> brew light <b>does not</b> stay on. (Light is on only while switch is pressed in.)	Bad timer or stop switch. (The stop switch provides voltage to the timer.)	-Check for voltage reaching the timer. If voltage is present, replace timer. If not, replace stop switch.
<b>Brew switch</b> will not start brew cycle (no water is dispensed) <i>and</i> brew light <b>does</b> come on.	No water reaching the brewer. Verify by dispensing water from hot water faucet for several seconds. Water should flow freely and steadily.	-Make sure the shut off valve is open. -Check water line for kinks; replace line if necessary -Check to see if filter is clogged by changing it.
	Bad dispense valve. (Brewer may buzz when in brew cycle)	-Replace the dispense valve
<b>Short brew levels EVERY BREW</b>  (One or both sides are affected and levels are consistent)	Water filter clogged	(See details in next section)
	Dispense valve clogged	-Clean and/or replace the dispense valve.
	Timer/s are set too low	-Advance timers to proper level.
	Incoming Voltage is too low for timers to function at proper time sequences	-Reset wall circuit breaker as one side may drop out & not flag the breaker. -Call an electrician to find loose connections in the building
<b>Short brew levels SOME BREWS</b>  (One or Both sides are affected and levels are erratic)	Water filter clogged. (problem is worse during simultaneous brews)	-Replace water filter
	Weak dispense valve (may buzz during cycle)	-Replace dispense valve.
	Water pressure or flow rate is too low or fluctuates too much to support a full brew. (problem is worse during simultaneous brews)	-Make sure brewer has a dedicated water line -Ensure that the shut off valve is open all the way (Never use needle saddle valves) -Increase the diameter of the water line to the brewer and or find stable source.
<b>Brew time required to fill dispensers is not the same for both sides</b>	Brewer is not level	-With an accurate level, level the brewer front to back and left to right by adjusting the feet.
<b>High brew levels EVERY BREW</b> (overfills but eventually does stop)  <b>SOME BREWS</b>	Timer/s are set too high	-Adjust timers down to appropriate level
	Dispenser not empty	-Empty the dispenser and try again
<b>Brew basket or filter overflows</b>		-Call FETCO Service Dept. to discuss. (800) 338-2699
<b>Weak Coffee</b>	Improper dose	-Measure and confirm correct dose
	Too many filter papers	-Make sure only one paper is used
	Low brew temperature (Temperature inside the hot water tank should be set to 205° F.)	-Adjust thermostat so the water stream measured at the bottom of the brew basket, 1/3 of the way through the brew cycle, equals 195 degrees + or - 5 degrees
<b>Grounds not saturated</b>	Half batch used incorrectly	-Use smaller brew basket -Discourage half batch use
	Water Softener in use	-Move brewer water feed to a non-softened source.
	Degassing - extremely fresh coffee	-Call FETCO Service Dept. to discuss. (800) 338-2699
<b>Spray head / brew basket drips - MAJOR or MINOR one side only</b>	Dispense valve not sealing properly.	-Clean, rebuild, or replace dispense valve.
<b>Spray head / brew basket drips - MAJOR or MINOR double brewers - right side only</b>	Fill valve not sealing (Will drip even with power off.)	-See next section - "Brewer won't stop brewing", "Bad or stuck fill valve".

Brewing Problem	Possible Cause	Solution
<b>Brewer won't stop brewing</b> (not the same as high brew levels)	Water pressure over 75psi	-Place a water pressure regulator on the line and reduce to 20-75 psi
	Water level probe bad or encrusted with lime. (causes brewer to continue filling hot water tank which will overflow into the brew baskets)	-Clean lime build up on the probe tip and/or tank wall. (Holding the probe wire (green) from the probe end to the body of the brewer should stop the fill if the probe is bad but the liquid level board is good)
	Bad liquid level control board	-Replace the LLC board if grounding the probe end of the (green) probe wire to the body of brewer does not remove the voltage at the fill terminal on the LLC board.
	Bad or stuck fill valve	-Rebuild or replace the fill valve if no voltage is on the coil (it is not magnetic) and it still passes water to the tank. (Disconnect the outlet side to see if it leaks water to the tank)
	Reverse osmosis water system. (Mineral content is too low for liquid level control board to operate properly.)	-Call FETCO Service Department to discuss. (800) 338-2699.
<b>Coffee tastes too strong</b>	Incorrect dosage	-Measure and confirm the correct amount of coffee required
	Short brew levels	-See "Short brew levels", above.

Temperature Problem (brewer only)	Possible Cause	Solution
<b>See also dispenser problems</b>		
<b>Brew water is cold / not hot enough, ready light is OFF.</b> (Before proceeding, make sure water tank refills when water is dispensed. The brewer will not heat unless the tank is full.)	No power to brewer.	-Make sure power switch is on -Check power connection. (plug or hard wire connection) -Check the wall circuit breaker / reset -Reset the circuit breaker, located on the back of the brewer. Press and release the white button.
	Defective liquid level control board. (No power to thermostat).	-With power on, and water tank full, check LLC board for 120 volts on brown wire and neutral. Replace LLC board if there is no voltage.
	Bad connections on mercury relay. (No power to heaters).	-Check relay for burned or loose connections. Replace with high temperature connectors if necessary.
	Defective mercury relay. (No power to heaters).	-Check input and output voltages on relay. 120 volts on blue wire (input) but no voltage out to heaters indicates a bad relay.
	Bad heating element/s.	-Check amperage draw on heater wires. 0 amps = bad heater.
<b>Brew water is cold / not hot enough, ready light is ON.</b>	Bad Thermostat (the thermostat believes that it is at set temperature)	-Replace the thermostat and or thermal probe. It's not possible to trouble shoot the probe.
	Low brew temperature setting on thermostat	-See "Low brew temperature" under " <b>Weak Coffee</b> " section.
<b>Slow to recover temperature</b>  (Ready light takes a long time to come back on after brewing.)	Brewers with more than one heater can have just one fail. (CBS-32 - 120/220 volts only)	-Check amperage draw on heater wires. 0 amps = bad heater.
	Hot water tank limed up	-Remove access cover to the hot water tank and inspect for lime. Remove the brewer for shop de-liming if build up is thick.
<b>Boiling and Steams</b>	Thermostat set too high for altitude (Denver etc.)	-Reduce temperature setting to 3 degrees below boiling at your altitude
	Defective thermostat	-Replace the thermostat and or thermal probe. It's not possible to trouble shoot the probe.

Dispenser Problem	Possible Cause	Solution
<b>Coffee not hot enough</b>	Attempting to hold coffee too long.	-Review discard times
	Using 1/2 batch on regular basis	-Encourage full batch use except at end of day or shift. Explore the need for smaller dispensers
<b>Parts related problems</b>		-Contact dispenser manufacturer: Zojirushi - (800) 733-6270 / Techni-Brew - (800) 545-4077

