

***INSTALLATION, OPERATION,
& MAINTENANCE MANUAL***
COOL ZONE ELECTRIC FRYERS (CE)



A WELBILT Company

DEAN INDUSTRIES

14501 South Broadway, Gardena, California 90248

Dean Factory Service Center

1-800-551-8633

1-318-865-1711

Printed in the United States of America
English

P/N 819-5729
November 1999

Please read all sections of this manual and retain for future reference.

NOTICE

IF, DURING THE WARRANTY PERIOD, THE CUSTOMER USES A PART FOR THIS ENODIS EQUIPMENT OTHER THAN AN UNMODIFIED NEW OR RECYCLED PART PURCHASED DIRECTLY FROM FRYMASTER DEAN, OR ANY OF ITS AUTHORIZED SERVICE CENTERS, AND/OR THE PART BEING USED IS MODIFIED FROM ITS ORIGINAL CONFIGURATION, THIS WARRANTY WILL BE VOID. FURTHER, FRYMASTER DEAN AND ITS AFFILIATES WILL NOT BE LIABLE FOR ANY CLAIMS, DAMAGES OR EXPENSES INCURRED BY THE CUSTOMER WHICH ARISE DIRECTLY OR INDIRECTLY, IN WHOLE OR IN PART, DUE TO THE INSTALLATION OF ANY MODIFIED PART AND/OR PART RECEIVED FROM AN UNAUTHORIZED SERVICE CENTER.

NOTICE

This appliance is intended for professional use only and is to be operated by qualified personnel only. A Frymaster Dean Factory Authorized Service Center (FASC) or other qualified professional should perform installation, maintenance, and repairs. Installation, maintenance, or repairs by unqualified personnel may void the manufacturer's warranty. See Chapter 1 of this manual for definitions of qualified personnel.

NOTICE

All fryers shipped without factory supplied cords and plug assemblies must be hardwired using flexible conduit to the terminal block located on the rear of the fryer. These fryers should be wired to NEC specifications. Hardwired units must include installation of restraint devices.

NOTICE

This equipment must be installed in accordance with the appropriate national and local codes of the country and/or region in which the appliance is installed.

NOTICE

Drawings and photos used in this manual are intended to illustrate operational, cleaning and technical procedures and may not conform to onsite management operational procedures.

NOTICE TO OWNERS OF UNITS EQUIPPED WITH COMPUTERS

U.S.

This device complies with Part 15 of the FCC rules. Operation is subject to the following two conditions: 1) This device may not cause harmful interference, and 2) This device must accept any interference received, including interference that may cause undesired operation. While this device is a verified Class A device, it has been shown to meet Class B limits.

CANADA

This digital apparatus does not exceed the Class A or B limits for radio noise emissions as set out by the ICES-003 standard of the Canadian Department of Communications.

Cet appareil numérique n'émet pas de bruits radioélectriques dépassant les limites de classe A et B prescrites dans la norme NMB-003 édictée par le Ministre des Communications du Canada.

⚠ DANGER

Improper installation, adjustment, maintenance or service, and unauthorized alterations or modifications can cause property damage, injury, or death. Read the installation, operating and service instructions thoroughly before installing or servicing this equipment. See Chapter 1 of this manual for definition of qualified service personnel.

⚠ DANGER

The front ledge of the fryer is not a step. Do not stand on the fryer. Serious injury can result from slips or contact with the hot oil.

⚠ DANGER

Single fryers equipped with legs must be stabilized by installing anchor straps. All fryers equipped with casters must be stabilized by installing restraining chains

⚠ DANGER

Do not store or use gasoline or other flammable vapors and liquids in the vicinity of this or any other appliance.

⚠ DANGER

The crumb tray in fryers equipped with a filter system must be emptied into a fireproof container at the end of frying operations each day. Some food particles can spontaneously combust if left soaking in certain shortening material. Additional information can be obtained in the filtration manual included with the system.

⚠ WARNING

No structural material on the fryer should be altered or removed to accommodate placement of the fryer under a hood. Questions? Call the Frymaster Dean Service Hotline at 1-800-551-8633.

⚠ WARNING

Do not bang fry baskets or other utensils on the fryer's joiner strip. The strip is present to seal the joint between the frypot. Banging fry baskets on the strip to dislodge shortening will distort the strip, adversely affecting its fit. It is designed for a tight fit and should only be removed for cleaning.

⚠ DANGER

Adequate means must be provided to limit the movement of this appliance without depending on or transmitting stress to the electrical conduit. A restraint kit is provided with the fryer. If the restraint kit is missing contact your local Frymaster Factory Authorized Service Center (FASC) for part number [826-0900](tel:826-0900).

⚠ DANGER

This fryer may have two power cords and prior to movement, testing, maintenance and any repair on your Frymaster fryer; disconnect BOTH electrical power cords from the electrical power supply.

DEAN

COOL ZONE ELECTRIC FRYERS (CE)

INSTALLATION, OPERATION, & MAINTENANCE MANUAL

TABLE OF CONTENTS

	PAGE
1 PARTS ORDERING/SERVICE INFORMATION	2
2 IMPORTANT INFORMATION	3
3 INSTALLATION	5
4 DAILY OPERATION	10
5 CLEANING AND MAINTENANCE	12
6 OPERATOR TROUBLESHOOTING	14
7 WIRING DIAGRAM	15

1. PARTS ORDERING AND SERVICE INFORMATION

1.1 ORDERING PARTS:

Customers may order parts directly from their local Authorized Parts Distributor. For this address and phone number, contact your Maintenance & Repair Center or call the Dean Factory Service Hotline. The factory address and phone numbers are on the cover of this booklet.

To speed up your order, the following information is required:

Model Number	_____
Serial Number	_____
Type of Voltage	_____
Item Part Number	_____
Quantity Needed	_____

1.2 SERVICE INFORMATION:

Call the Dean Factory Service Hotline number on the cover of this booklet for the location of your nearest Maintenance & Repair Center or contact the factory direct. Always give the model and serial numbers of your filter and fryer.

To assist you more efficiently, the following information will be needed:

Model Number	_____
Serial Number	_____
Voltage	_____
Nature of the Problem	_____
Any other information which may be helpful in solving your service problem.	

1.3 AFTER SALES:

In order to improve service, have the following chart filled in by the Dean Authorized Servicer who installed this equipment.

Authorized Servicer	_____
Address	_____

Telephone/Fax	_____
Model #	_____
Serial #	_____
Type:	_____
Fryer Equipped For:	_____

2. IMPORTANT INFORMATION

2.1 DESCRIPTION: The Dean Cool Zone (CE) electric fryers are energy-efficient, electrically heated units, certified by NSF and the Underwriters Laboratory and manufactured to their basic performance and application specifications. The Dean Cool Zone (CE) electric fryers are certified for installation and operation in the European Community (CE).

Units are shipped completely assembled with any accessories packed inside the fryer vessel. They are adjusted, tested, and inspected at the factory prior to crating for shipment. Sizes, weights and input rates are listed in this manual.

2.2 DESIGN SPECIFICATIONS:

- a. **VESSEL CONSTRUCTION:** Welded, heavy gauge steel with three heater elements fixed inside the vessel with a protective, chromed wire mesh crumb screen over the elements. A drain is tapped into front right corner of vessel with a front-controlled manual drain valve.
- b. **BODY CONSTRUCTION:** An aluminized steel base with stainless steel front and enamel sides. The frame is supported by 15 cm (6 inches) adjustable legs or optional 15 cm (6 inches) rigid rear casters.
- c. **OPERATING CONTROLS:** Unit is shipped standard with a liquid filled bulb thermostat. The temperature control is mounted in the cabinet behind the front door on the bottom left side of the cabinet.
- d. **AUTOMATIC SAFETY FEATURE:** High temperature detection to shut off electric heater elements should the controlling thermostat fail.
- e. **RATING PLATE:** This is attached to the inside front door panel. Information provided includes the

kilowatt (kW) output of the heater elements and electrical requirements.



DANGER!

THE FRYER MUST BE CONNECTED ONLY TO THE TYPE OF ELECTRICAL SERVICE IDENTIFIED ON THE ATTACHED RATING PLATE.

2.3 PRE-INSTALLATION:

- a. **GENERAL:** A licensed electrician should install any commercial electric cooking equipment.
- b. **CLEARANCES:** The fryer area must be kept free and clear of all combustibles. This unit is design-certified for the following installations:
 1. Other than household use.
 2. Non-combustible floor installation equipped with factory-supplied 15 cm (6 inch) adjustable legs, optional 13 cm (5 inch) rigid rear casters, or optional 13 cm (5 inch) locking swivel casters.
 3. Combustible construction with a minimum clearance of 15 cm (6 inches) side and 15 cm (6 inches) rear, and equipped with factory-supplied 15 cm (6 inches) adjustable legs or 13 cm (5 inches) casters.

CAUTION

Local building codes usually prohibit a fryer with its open tank of hot oil from being installed beside an open flame of any type, whether a broiler or the open burner of a range.

- c. **STANDARDS:** All electrical cooking appliances must be electrically connected and grounded in accordance with local codes, or in the absence of local codes, with the latest editions of the European Community (CE) standards.

2.4 AIR SUPPLY & VENTILATION:

- a. The area around the fryer must be kept clear to prevent any obstruction to ventilation air flow as well as for service and maintenance. Never use the interior of the fryer's cabinet for storage.
- b. A commercial, heavy-duty fryer should be vented to the outside of the building.
- c. Filters and drip troughs should be part of any industrial hood, but consult local codes before constructing and installing any hood.

2.5 RECEIVING AND UNPACKING:

Check that the container is upright. Unpack the fryer carefully and remove all accessories from the carton. Do not discard or misplace these, as they will be needed.

After unpacking, immediately check the equipment for visible signs of shipping damage. If such damage has occurred, contact the carrier and file the appropriate freight claims. Do not contact the factory, as the responsibility of shipping damage is between the carrier and the dealer or end-user.

If your equipment arrives damaged:

- ◆ File claim for damages immediately, regardless of extent of damage.
- ◆ Visible loss or damage: Be sure this is noted on the freight bill or express receipt and is signed by the person making the delivery.

- ◆ Concealed loss or damage: If damage is unnoticed until equipment is unpacked, notify freight company or carrier immediately, and file a concealed damage claim. This should be done within fifteen (15) days of date of delivery. Be sure to retain container for inspection.

NOTE: Dean does not assume responsibility for damage or loss incurred in transit.

3. INSTALLATION

3.1 POSITIONING:

- a. Initial Installation: If installed with legs, do not push against any unit edges to adjust its position. Use a pallet or lift jack to lift it slightly and place it where it is to be installed.
- b. Relocating The Fryer: If relocating a fryer installed with legs, remove all weight from each leg before moving.

Note: If a leg becomes damaged during movement, contact your service agent for immediate repair/replacement of that leg.



DANGER!

THIS FRYER MAY TIP AND CAUSE PERSONAL INJURY IF NOT SECURED CORRECTLY IN A STATIONARY POSITION. REMOVE ALL SHORTENING BEFORE MOVING FRYER AS IT MAY CAUSE SEVERE BURNS UPON CONTACT.

3.2 LEG AND CASTER INSTALLATION:

a. General:

1. Install legs and optional rear rigid casters near where the fryer is to be used, as neither are secure for long transit. Unit cannot be curb mounted and must be equipped with the legs (or legs and optional rigid casters) provided.
2. When positioning the fryer, gently lower the fryer into position to prevent undue strain to the legs and internal mounting hardware. Use a pallet or lift jack to lift and position the fryer if possible. Tilting the fryer may damage the legs.

3. If the optional rigid casters are to be installed on single fryers, the casters must be installed on the fryer rear channel assembly only.
4. Proceed to Step 3.3, Leveling, after legs and/or optional rear rigid casters are installed to ensure the fryer is level before using.

b. Leg Installation:

1. Remove unit from pallet.
2. Carefully raise unit with forklift, pallet jack, or other steady means.
3. Place one lock washer on each hex head screw.
4. Insert hex head screws with lockwashers (1/4-20 threads by 19mm (3/4") long) through bolt holes of leg mounting plates as shown in the Figure 3-1 on the next page. A locknut has been attached to the top side of the mounting plate at the factory to capture the hex head screw as it is screwed in.
5. Tighten the bolts and nuts to 5.65 joules (50 inch-lbs.) minimum torque.

CAUTION

For leg and caster installations, the unit must be at room temperature and drained of shortening before installing the legs and/or casters.

c. Installing Optional Rear Rigid Casters:

1. Install rear rigid casters only at the rear of the single fryer as shown in the Figure 3-1. Legs must be installed at the front of the fryer.
2. Follow the same instructions for leg installations as given above in steps 3.2.b.1-5.

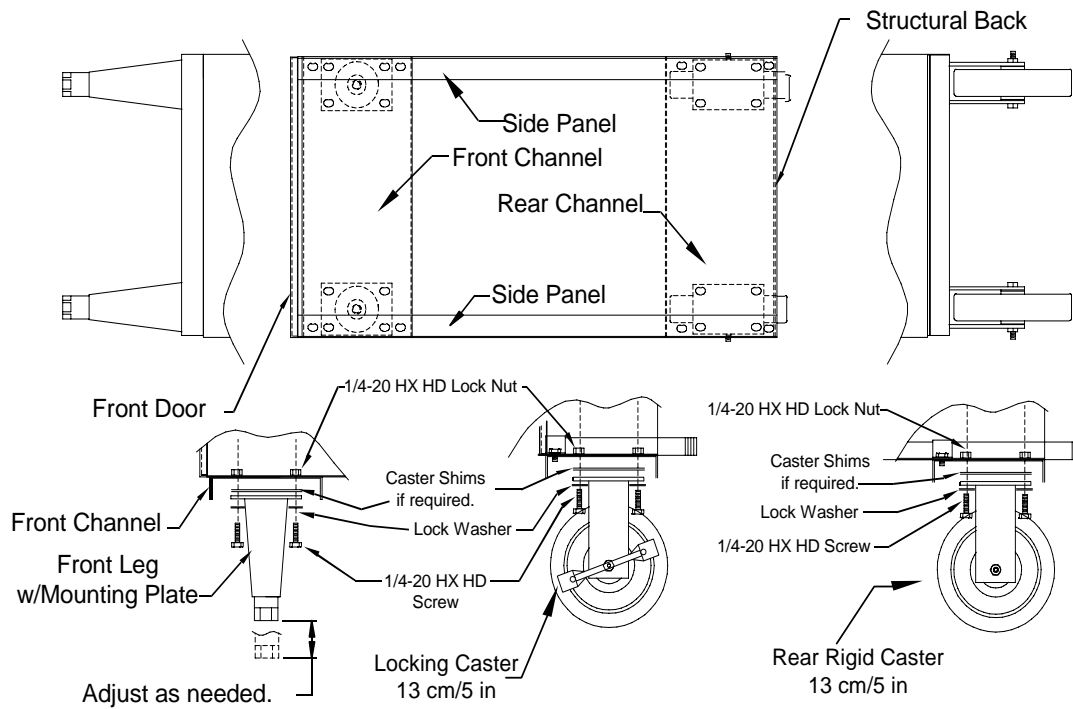

Leg and Caster Installations
Figure 3-1

d. **Installing Optional Swivel Casters:**

1. Swivel casters can only be used with multiple fryer batteries (two or more fryers battered together).
2. Install non-locking casters only at the rear of the unit as shown in the Figure 3-1.
3. Locking casters must be installed at the front of the unit. This allows the fryer to be "locked" in position for safe operations.
4. Follow the same instructions for leg installations as given above in steps 3.2.b.1-5.

3.3 LEVELING:

- a. Place a carpenter's spirit level across the top of the fryer and level the unit both front-to-back and side-to-side. If the fryer is not level, the unit may not function efficiently, the oil may not drain properly for filtering and in a line-up it may not match adjacent units.
- b. **Legs (Only):**
 1. If the floor is smooth and level, level the unit by using the caster shims. Adjust to the high corner and measure with the spirit level.
 2. Adjust leg height with an adjustable or 27mm (1-1/16") open end wrench by turning the hex bullet on the bottom of the leg. See figure 3-2 on page 7.
 3. **The hex bullet is for minor leg height adjustment only. Do not adjust more than 22mm (1").**



WARNING!

A FRYER MUST BE LEVEL BEFORE FILLING WITH OIL. IF THE FRYER IS NOT LEVEL, THE FRYER MAY TIP OVER AND MAY CAUSE INJURY TO THE OPERATOR.

4. When leveling the unit, the leg body should be held firmly to keep the leg from rotating while turning the hex bullet foot to the required height.



Adjust leg height with an adjustable wrench.

Figure 3-2



WARNINGS!

DO NOT USE MORE THAN TWO METAL SHIMS PER LEG/CASTER. USING MORE THAN TWO SHIMS PER LEG/CASTER MAY CAUSE THE FRYER TO BECOME UNSTABLE, TIP OVER, AND MAY CAUSE INJURY TO THE OPERATOR.

IF OPTIONAL SWIVEL CASTERS ARE USED ON A MULTIPLE FRYER BATTERY, LOCKING CASTERS MUST BE INSTALLED ON THE FRYERS' FRONT CHANNEL. FAILURE TO LOCK CASTERS PRIOR TO OPERATING THE FRYERS MAY CAUSE THE FRYERS TO MOVE AND CAUSE INJURY TO THE OPERATOR.

c. **Rigid Casters (Only):**

1. Install the optional rigid casters on the fryer rear channel only. Legs

must be installed on the front channel.

2. Do not use more than two metal shims per caster.
3. There are no thread adjustments for the rigid casters.

d. **Swivel Casters (Only):**

1. Multiple fryer batteries (only): If optional swivel casters are used, the locking swivel casters must be installed on the fryer front channel. **Lock casters prior to operating the fryer.**
 2. Install non-locking swivel casters on the fryer rear channel only.
 3. Do not use more than two metal shims per caster.
 4. There are no thread adjustments for the swivel casters.
- e. If the floor is uneven or has a decided slope, it is recommended to place the fryer on a smooth platform. Do not rely on leg thread or caster shims for adjustments.
- f. If the fryer is moved, re-level the fryer following the instructions given in Steps 3.3.a-c.
- g. This fryer must be restrained to prevent tipping when installed in order to avoid the splashing of hot liquid. The means of restraint may depend on the type of application, such as connecting to a battery of appliances or installing the fryer in an alcove, or by separate means, such as restraining devices. A bracket has been provided on the fryer back panel for this purpose.

The install must be reviewed at the time of installation to ensure it meets the intent of these instructions. The on-site supervisor and/or operator(s) should be made aware that there is a

restraint on the appliance and, if disconnection of the restraint is necessary, to reconnect this restraint after the appliance has been returned to its originally installed position.

CAUTION

The fryer **MUST** be connected to the voltage and phase as specified on the rating and serial number plate located on the back of the fryer door.

A ground wire **MUST** be connected to the ground terminal provided near the input power terminal block.

3.4 ELECTRICAL CONNECTIONS:

Plan and carry out installation in accordance with local codes.

- a. Connections: Connections to the terminal block and grounding lug should be made through the hole provided for this purpose in the junction box. To install this fryer, the servicer/installer must use a goose neck and retainer to protect the cord set.
- b. Wiring Diagram: It is attached to the inside of the fryer door. Amperage for each unit depends on the type of installation and accessories supplied with the unit. A 230/400V Wiring Diagram is provided in Chapter 7.

3.5 INITIAL START-UP:

- a. CLEANING: New units are wiped clean with solvents at the factory to remove any visible signs of dirt, oil, grease, etc. remaining from the manufacturing process, then coated lightly with oil. Wash thoroughly with hot, soapy water to remove any film residue and dust or debris before food preparation, then rinse out and wipe dry. Wash also any accessories shipped with the unit. Close the drain valve completely and remove the

crumb screen. Make sure the screws holding the thermostat and hi-limit control sensing bulbs are tight.

- b. HEATING THE VESSEL: This step checks heater element operation, initial thermostat calibration, and cleans the vessel for initial food production.
 1. Fill the fryer vessel with hot or cold water to the oil level line scribed in the back of the tank.
 2. Set the thermostat/temperature controller dial to 104°C/220°F, just above that of boiling water.
 3. Toggle the power switch "ON". The heater elements will begin heating.
 4. When the water starts to boil, turn the dial to below 99°C/210°F. The elements will turn off and the water will stop boiling.
 5. When satisfied that the heaters and thermostat operate properly, drain the vessel of water and dry thoroughly. Refill fry vessel with shortening as directed in section 3.6, Final Preparation.



Temperature Controller Power Switch

Figure 3-3

3.6 FINAL PREPARATION:

- a. When using liquid shortening (cooking oil), fill the fryer to the “oil level” line scribed into the back of the fryer vessel.
- b. When using solid shortening, either melt it first, or cut into small pieces and pack into cool zone (bottom) of the frying vessel. Do not leave any air spaces or disturb the sensing bulbs. Melt shortening by turning the heaters “ON” for five or ten seconds, “OFF” for a minute, repeating cycle until shortening is melted. If oil starts to smoke while melting this way, shorten the “ON” cycle and lengthen the “OFF” cycle. Smoke indicates oil scorching, shortening its useful life.

NOTE: Never melt a solid block of shortening by setting it in the vessel or on top of the heating elements. This is unsafe, inefficient and dangerous.

- c. **When the fryer vessel is filled and the shortening melted, replace the crumb screen gently over the heater elements to prevent splashing of hot oil. Wear gloves when replacing the crumb screen.**
- d. Before starting operation, turn the temperature controller to the probable working temperature; wait for the temperature to stabilize then check with a high-quality immersion thermometer.



WARNINGS!

NEVER OPERATE FRYER WITHOUT ENOUGH COOKING COMPOUND OR WATER IN THE VESSEL TO COVER THE HEATING ELEMENTS.

ALWAYS WEAR OIL-PROOF, INSULATED GLOVES WHEN WORKING WITH THE FRYER FILLED WITH HOT OIL.

ALWAYS DRAIN HOT OIL INTO A METAL CONTAINER. HOT OIL CAN MELT PLASTIC BUCKETS AND CRACK GLASS CONTAINERS.

4. DAILY OPERATION

4.1 OPENING: At opening time, always visually check that the power switch and the thermostat are “OFF”.

CAUTION

If electrical power service is disrupted for more than a few seconds, turn fryer OFF. This will prevent the fryer from accidentally heating oil when power service is resumed.

4.2 GENERAL USE:

- a. For consistent quality product, convenience and long-term savings, use a high-quality liquid frying compound.



WARNING!

IF USING SOLID SHORTENING, NEVER MELT A BLOCK OF SHORTENING BY SETTING IT WHOLE IN THE FRYER VESSEL. THIS IS DANGEROUS AND CAN EASILY CAUSE THE SHORTENING SCORCHING, DAMAGE TO THE ELEMENTS OR POSSIBLY A FIRE.

- b. Although a temperature of 177°C (350°F) is recommended for most cooking operations, set the fryer at the lowest possible temperature which produces a high-quality end product while ensuring maximum life of frying compound.
- c. When the fryer is not in use, the thermostat should be set lower than that used during cooking.

4.3 TURN ON PROCEDURES:

- a. If fryer is empty, pour enough shortening into the vessel to fill the vessel to the "oil level" line scribed on the rear wall. If solid shortening is to be used, melt enough in a separate container to cover the heating elements in the bottom of the vessel, then melt the rest in the vessel by turning power switch off and on.
- b. Turn the power switch on; set temperature controller to 177°C (350°F). In less than 30 minutes, the frying compound temperature will stabilize and be ready for production.

4.4 FILTERING:

- a. General: Filtering the shortening assures a better taste to the food, minimizes flavors being transferred from batch to batch, and increases frying compound lifespan.

Filter the frying compound at least once daily or more frequently if cooking is heavy.

- b. Prior to filtering, align the portable filter unit under the drain valve. Attach the drain valve extension to ensure shortening flows into the filter safely.
- c. If using solid shortening, clear return lines before turning off the filter motor and hang any flexible lines up to drain. As it cools, solid shortening solidifies and clogs lines.
- d. For more detailed information concerning filtration, review the operator's manual shipped with your filter unit.

CAUTION

When filtering, never leave the filter unattended. Always point the flexible oil return hose nozzle down into the fry vessel to prevent spraying of hot oil which may cause severe burns.

4.5 CLOSING: When closing at night, filter oil in all fryers and drain the filter lines. Cover the open tanks of oil. Turn power switch “OFF”.

4.6 SHUTDOWN: When shutting down for periods longer than overnight, drain the frying compound and clean the vessel thoroughly. Either discard the frying compound or return it filtered to the vessel and then cover it. Turn both the power switch and temperature controller “OFF”.

5. CLEANING & MAINTENANCE



WARNING

IF FRYER IS NOT COMPLETELY EMPTY OF OIL, ADJUSTMENT, ALTERATION, SERVICE OR MAINTENANCE CAN CAUSE PROPERTY DAMAGE AND PERSONAL INJURY.

5.1 GENERAL: Any piece of equipment works better and lasts longer when maintained properly and kept clean. Cooking equipment is no exception. The fryer must be kept clean during the working day and thoroughly cleaned at the end of each day.

5.2 DAILY: Wash all removable parts. Clean all exterior surfaces of the body. Do not use cleansers, steel wool, or any other abrasive material on the stainless steel. Filter the cooking oil and replace if necessary. The oil should be filtered more often than daily under heavy use conditions.

5.3 ACCESS FOR SERVICING:

The appliance is equipped with a bracket attached on the center of the structural back to connect a restraining device supplied by the installer. The restraining device should meet the requirements specified in section 3.3.f of this manual. In addition, if the installed fryers have casters provided by Dean Industries, both rear casters come with a locking mechanism that prevents the fryer from moving when the lever or each mechanism is turned "ON".

To gain access for servicing, the restraining device has to be removed from the bracket and both front caster's locking mechanisms have to be turned "OFF".

To return the unit to its previous installed position see sections 3.3 and 5.3 of this manual.

5.4 WEEKLY:

- a. Completely drain the oil from the fry vessel into either the filter or a steel container. Do not use a plastic bucket or glass container.
- b. Clean the vessel with a good grade of cleaner or hot water and a strong detergent.
- c. Close the drain valve and refill with either the cleaning solution or water and detergent.
- d. Set operating thermostat to 104°C (220°F). Bring to a rolling boil, then turn the heat down and let the mixture stand until deposits and/or carbon spots can be rubbed off with the Teflon brush.
- e. Scrub tank walls, bottom and heating tubes. Then drain vessel and rinse in clear water.

CAUTION

Do not drain water into the filter. Water will damage the filter pump.

- f. Refill with clear water, set operating thermostat to 104°C (220°F), and boil again. Once boiling is completed, turn operating thermostat "OFF", drain, rinse, and dry thoroughly.

CAUTION

Do not let water boil down to the point that elements are exposed as this will damage them.

- g. Immediately refill with cooking oil or frying compound as directed in Section 4.3.



WARNING

DO NOT LET WATER SPLASH INTO THE TANK OF HOT OIL. IT WILL SPLATTER AND CAN CAUSE SEVERE BURNS.

5.5 PERIODIC: The fryer should be checked and adjusted periodically by qualified service personnel as part of a regular kitchen maintenance program.

5.6 STAINLESS STEEL: All stainless steel fryer body parts should be wiped regularly with hot, soapy water during the day and with a liquid cleaner designed for this material at the end of each day.

- a. Do not use steel wool, abrasive cloths, cleansers or powders!
- b. Do not use a metal knife, spatula or any other metal tool to scrape stainless steel! Scratches are almost impossible to remove.
- c. If it is necessary to scrape the stainless steel to remove any encrusted materials, soak the area first to loosen the material, then use a wood or nylon scraper only.

6. TROUBLESHOOTING GUIDE

The problems and possible solutions given below cover those most commonly encountered by operators.

FOR DETAILED TROUBLESHOOTING AND SERVICE-RELATED INFORMATION, CALL THE DEAN SERVICE HOTLINE AT 1-800-551-8633 (USA/Canada only) or 1-318-865-1711.

PROBLEM	CORRECTIVE ACTION
<p>Operator hears click sound when the temperature controller dial is turned but vessel remains cold. No evidence that elements are warming the vessel.</p>	<p>With the power switch "ON":</p> <ol style="list-style-type: none"> 1. Manually reset the high temperature limit switch (push red button on the panel above the drain valve). See Figure 6-1. 2. Check for tripped branch or main circuit breakers or blown fuses.
<p>Poor temperature control on the cold side or hot side; excessive warm-up time; temperature recovery is slow or inadequate when vessel is loaded; uneven heating; excessive temperature overshooting during warm-up; scorching; overheating; or high limit switch must be reset often.</p>	<p>Check thermostat adjustment:</p> <ol style="list-style-type: none"> 1. Check that the thermostat bulb/probe in the vessel has not been knocked loose from its operating position. It should be clamped to the second element with 1,5 mm (1/16 inch) spacing. See Figure 6-2. 2. Place the sensing bulb of a high quality immersion thermometer about 38 mm (1-1/2 inches) above the thermostat sensing bulb and set the temperature controller dial to 177°C (350°F). 3. Wait at least 30 minutes for the oil temperature to stabilize. 4. If temperature is not within +/- 5°C (10°F) of the dial setting, call service for a new operating thermostat/temperature controller.

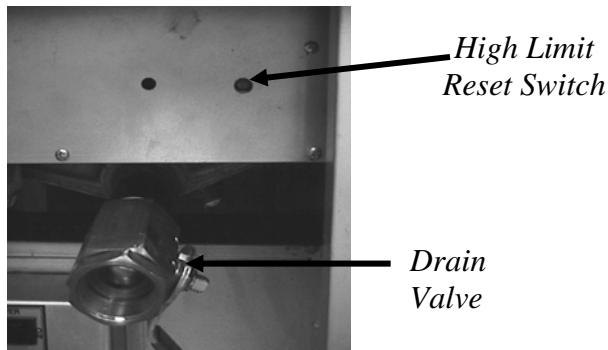

Figure 6-1

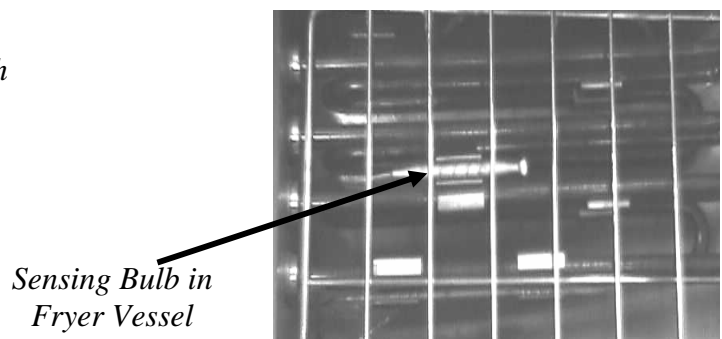
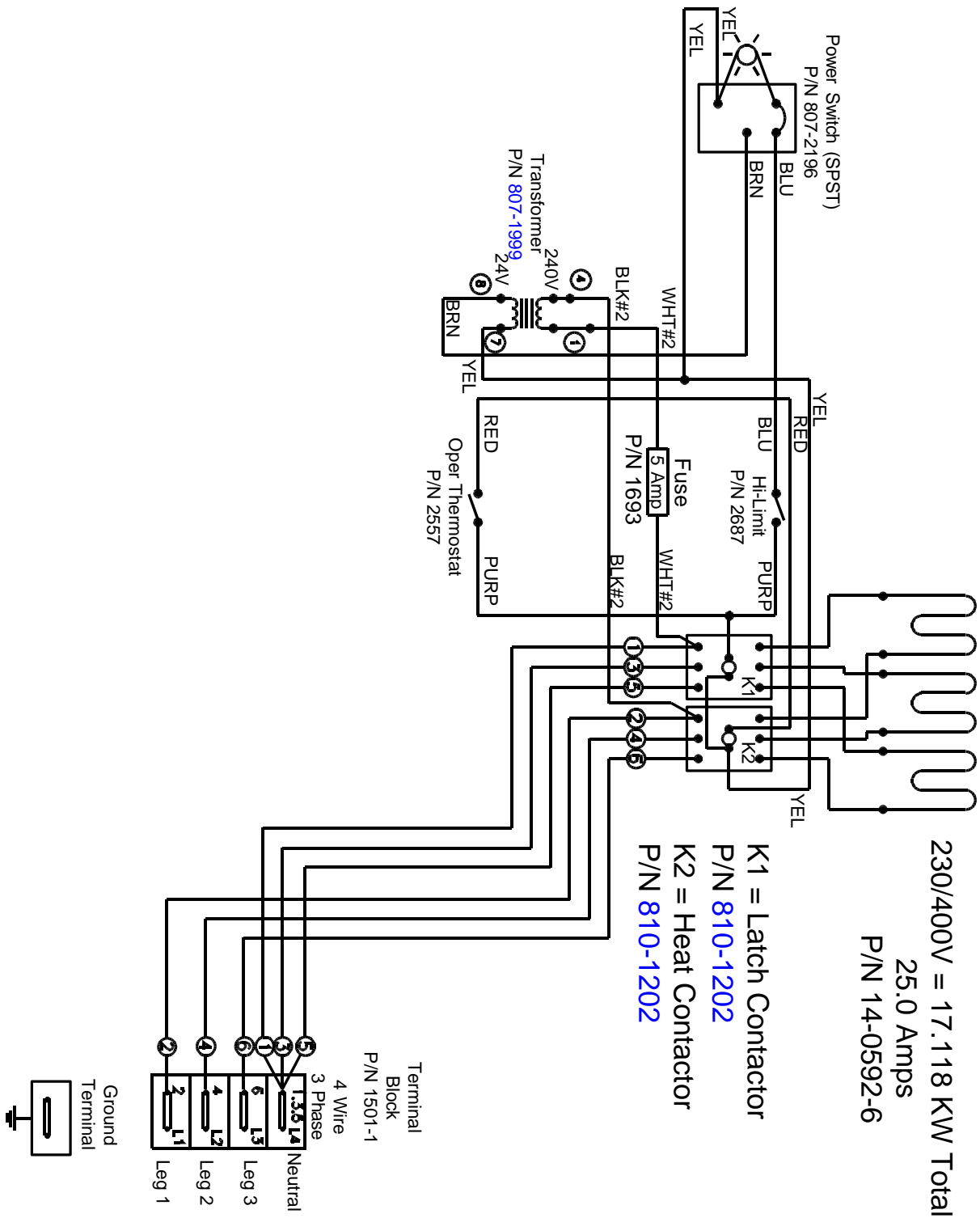

Figure 6-2

7. WIRING DIAGRAM



Wiring Diagram Cool Zone Electric Fryer (CE)

Electric Fryer 230/400V 24V Contactors
 June 1999

8. COOL ZONE 1414E ELECTRIC (CE) PARTS LIST

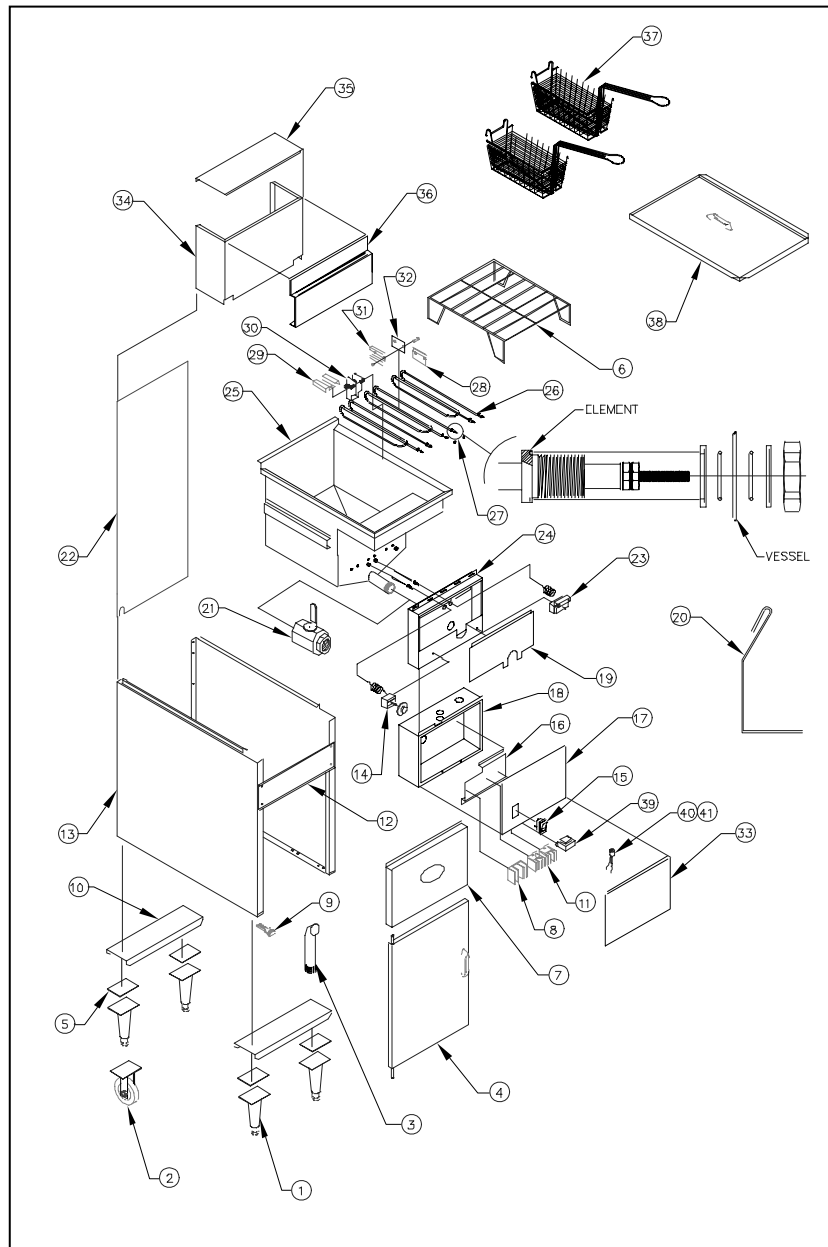

ITEM	PART NUMBER	DESCRIPTION
1	2698	LEG, BLACK, ADJUSTABLE WITH MOUNTING PLATE, 6"
2	1942	CASTER, 5" W/BRAKE
	1943	CASTER, 5" W/O BRAKE
3	44-1363	NIPPLE, DRAIN EXT. 1-1/4"
4	36004-1	DOOR ASSY
	36-0014-1	DOOR PANEL
	12-0097	DOOR PIN
	1503	MAGNETIC DOOR CATCH
	1039-2	HANDLE, CHROME/DOOR
5	9002949	SHIM CASTER
6	12220	GRID ASSEMBLY
7	12-0309-2	FRONT CNTRL PANEL
8	1501	TERMINAL BLOCK 3 WIRE
	1501-1	TERMINAL BLOCK 4 WIRE

ITEM	PART NUMBER	DESCRIPTION
9	24-0350	LOWER HINGE BRACKET
10	36-0012	FRT & REAR CHANNEL
11	8101202	40 AMP 3 POLE CONTACTOR (CE Only)
12	12-0311	CNTRL PANEL BACK SR38
13	50-0041-1	SIDE PANEL PP/GREY LH
	50-0041-2	SIDE PANEL PP/GREY RH
14	2557	THERMOSTAT, SUNNE #TC125-004
	1205	KNOB,THERMOS R/S KXD
15	2025	POWER SWITCH (ROCKER SWITCH, CARLING)
	8072196	POWER SWITCH (GRN LIGHTED ROCKER SWITCH)
16	12-0376	MOUNTING PLATE CONTCTR, SR38ECE
17	12-0323	COVER CONTACTOR BOX, SR38E
18	12210	BOX, CONTACTOR WELD ASSY,SR38E (CE)
19	12-0322	COVER HEATER RACEWAY, SR38E
20	14-0193	GOOFER ROD DECLOGGER
21	2066-1	DRAIN VALVE,1-1/4"(1"STD PORT)
22	36-0048	STRUCTURAL BACK
	12-0237	RESTRAINING BRACKET
23	2687	HI LMT 410 DEG F,W/MAN RESET CE
24	12212	BOX RACEWAY/CONTCTR ASSY,SR38E (CE)
25	14248-2	VESSEL WELD ASSY SS
26	14-0592-6	HEAT ELEMENT 208V 4666W
27	1902	O RING SEAL (4 EA ELEMENT)
	14-0695	O-RING RETAINER WASHER (4 EA ELEMENT)
	2189	JAM NUT 3/4-16 (2 EA ELEMENT)
28	18-0041	CLAMP; THERMOSTAT 1 EA USA, 2 EA CE
	14-0883	SPRING/ROBERTSHAW/SPACER
	18-0041	CLAMP; THERMOSTAT 1 EA USA, 2 EA CE
	18-0040	HIGH LIMIT CLAMP USA
29	18-0031	SPACER HEAT ELEMENT
30	12193	BRACKET ELEMENT SPRT, SR38E
31	18-0031	SPACER HEAT ELEMENT
32	18-0061	SUPPORT HEAT ELEMENT
33	12-0377	COVER, LOWER CNTRL BOX SR38E (CE Only)
34	Not Used	
35	Not Used	
36	36-0026-2	BASKET HANGER
37	2608	FRY BASKET
39	8071999	TRANSFORMER PRIMARY 208/240V (CE Only)
40	1692	FUSE HOLDER W/LEADS
41	1693	FUSE 5 A
Not Shown	14673	OPERATIONAL THERMOSTAT WIRING HARNESS
	44-1362	BRACKET,DRAIN NIPPLE EXTENSION



DEAN

Frymaster, L.L.C., 8700 Line Avenue, PO Box 51000, Shreveport, Louisiana 71135-1000
Shipping Address: 8700 Line Avenue, Shreveport, Louisiana 71106

TEL 1-318-865-1711

FAX (Parts) 1-318-219-7140

(Tech Support) 1-318-219-7135

PRINTED IN THE UNITED STATES

SERVICE HOTLINE
1-800-551-8633

* 8195729 *
Price: \$6.00

NOV 1999