

**SERVICE MANUAL
FRYMASTER BIPH52/55 AND MPH52/55 SERIES
GAS FRYERS**



This equipment chapter is to be installed in the Fryer Section of the *Equipment Manual*.

FOR YOUR SAFETY
Do Not Store or use gasoline or other flammable vapors and liquids in the vicinity of this or any other appliance.

**MANUFACTURED
BY**



Enodis
One Company. Countless Solutions

**P.O. BOX 51000
SHREVEPORT, LOUISIANA 71135-1000
PHONE: 1-318-865-1711
TOLL FREE: 1-800-551-8633
1-800-24 FRYER
FAX: 1-318-219-7135**



Frymaster, L.L.C. 8700 Line Avenue 71106, 5489 Campus Drive 71129
P.O. Box 51000, Shreveport, Louisiana 71135-1000
TEL 318-865-1711 FAX (Parts) 318-219-7140 (Tech Support) 318-219-7135

PRINTED IN THE UNITED STATES **SERVICE HOTLINE**

1-800-24-FRYER

www.frymaster.com

E-mail: service@frymaster.com

MAY 2006

* **8196094** *

NOTICE

IF, DURING THE WARRANTY PERIOD, THE CUSTOMER USES A PART FOR THIS ENODIS EQUIPMENT OTHER THAN AN **UNMODIFIED** NEW OR RECYCLED PART PURCHASED DIRECTLY FROM FRYMASTER DEAN, OR ANY OF ITS AUTHORIZED SERVICE CENTERS, AND/OR THE PART BEING USED IS MODIFIED FROM ITS ORIGINAL CONFIGURATION, THIS WARRANTY WILL BE VOID. FURTHER, FRYMASTER DEAN AND ITS AFFILIATES WILL NOT BE LIABLE FOR ANY CLAIMS, DAMAGES OR EXPENSES INCURRED BY THE CUSTOMER WHICH ARISE DIRECTLY OR INDIRECTLY, IN WHOLE OR IN PART, DUE TO THE INSTALLATION OF ANY MODIFIED PART AND/OR PART RECEIVED FROM AN UNAUTHORIZED SERVICE CENTER.

NOTICE

This appliance is intended for professional use only and is to be operated by qualified personnel only. A Frymaster DEAN Factory Authorized Service Center (FASC) or other qualified professional should perform installation, maintenance, and repairs. Installation, maintenance, or repairs by unqualified personnel may void the manufacturer's warranty.

NOTICE

This equipment must be installed in accordance with the appropriate national and local codes of the country and/or region in which the appliance is installed.

NOTICE TO U.S. CUSTOMERS

This equipment is to be installed in compliance with the basic plumbing code of the Building Officials and Code Administrators International, Inc. (BOCA) and the Food Service Sanitation Manual of the U.S. Food and Drug Administration.

NOTICE

Drawings and photos used in this manual are intended to illustrate operational, cleaning and technical procedures and may not conform to onsite management operational procedures.

NOTICE TO OWNERS OF UNITS EQUIPPED WITH COMPUTERS

U.S.

This device complies with Part 15 of the FCC rules. Operation is subject to the following two conditions: 1) This device may not cause harmful interference, and 2) This device must accept any interference received, including interference that may cause undesired operation. While this device is a verified Class A device, it has been shown to meet the Class B limits.

CANADA

This digital apparatus does not exceed the Class A or B limits for radio noise emissions as set out by the ICES-003 standard of the Canadian Department of Communications.

Cet appareil numérique n'émet pas de bruits radioélectriques dépassant les limites de classe A et B prescrites dans la norme NMB-003 édictée par le Ministre des Communications du Canada.

 WARNING

To ensure the safe and efficient operation of the fryer and hood, the electrical plug for the 120-volt line, which powers the hood, must be fully engaged and locked in its pin and sleeve socket.

⚠ DANGER

Improper installation, adjustment, maintenance or service, and unauthorized alterations or modifications can cause property damage, injury, or death. Read the installation, operating, and service instructions thoroughly before installing or servicing this equipment. Only qualified service personnel may convert this appliance to use a gas other than that for which it was originally configured.

⚠ DANGER

No structural material on the fryer should be altered or removed to accommodate placement of the fryer under a hood. Questions? Call the Frymaster Dean Service Hotline at 1-800-551-8633.

⚠ DANGER

Adequate means must be provided to limit the movement of this appliance without depending upon the gas line connection. Single fryers equipped with legs must be stabilized by installing anchor straps. All fryers equipped with casters must be stabilized by installing restraining chains. If a flexible gas line is used, an additional restraining cable must be connected at all times when the fryer is in use.

⚠ DANGER

The front ledge of the fryer is not a step! Do not stand on the fryer. Serious injury can result from slips or contact with the hot oil.

⚠ DANGER

Do not store or use gasoline or other flammable liquids or vapors in the vicinity of this or any other appliance.

⚠ DANGER

Instructions to be followed in the event the operator smells gas or otherwise detects a gas leak must be posted in a prominent location. This information can be obtained from the local gas company or gas supplier.

⚠ DANGER

This product contains chemicals known to the state of California to cause cancer and/or birth defects or other reproductive harm.

Operation, installation, and servicing of this product could expose you to airborne particles of glasswool or ceramic fibers, crystalline silica, and/or carbon monoxide. Inhalation of airborne particles of glasswool or ceramic fibers is known to the State of California to cause cancer. Inhalation of carbon monoxide is known to the State of California to cause birth defects or other reproductive harm.

⚠ DANGER

The crumb tray in fryers equipped with a filter system must be emptied into a fireproof container at the end of frying operations each day. Some food particles can spontaneously combust if left soaking in certain shortening material.

⚠ WARNING

Do not bang fry baskets or other utensils on the fryer's joiner strip. The strip is present to seal the joint between the fry vessels. Banging fry baskets on the strip to dislodge shortening will distort the strip, adversely affecting its fit. It is designed for a tight fit and should only be removed for cleaning.

WARRANTY STATEMENT

Frymaster, L.L.C. makes the following limited warranties to the original purchaser only for this equipment and replacement parts:

A. WARRANTY PROVISIONS - FRYERS

1. Frymaster L.L.C. warrants all components against defects in material and workmanship for a period of one year.
2. All parts, with the exception of the frypot, heating elements and fuses, are warranted for one year after installation date of fryer.
3. If any parts, except fuses and filter O-rings, become defective during the first year after installation date, Frymaster will also pay straight-time labor costs to replace the part, plus up to 100 miles/160 km of travel (50 miles/80 km each way).

B. WARRANTY PROVISIONS - FRYPOTS

(Applies to fryers manufactured after December 1, 2003, only.)

1. Frymaster warrants the frypot assembly for ten years parts and labor. Components attached to the frypot, such as the high-limit, probe, gaskets, seals, ignitors and related fasteners, are also covered by the ten-year warranty if replacement is necessitated by the frypot replacement. Components that are not part of the frypot assembly, such as the blower, gas valve, micro switches, doors and cabinetry are not covered by the frypot warranty. If the frypot is found to be defective, Frymaster will replace the frypot, allowing up to the maximum time per the Frymaster time allowance chart hours of straight-time labor plus up to 100 miles/160 km of travel (50 miles/80 km each way) to change the frypot.
2. This warranty is limited to fryers operating on natural or propane (LP) gas. Fryers that operate on manufactured gas (also known as town gas or high-hydrogen gas) have a lifetime frypot warranty, parts only.

C. WARRANTY PROVISIONS – COMBUSTION CHAMBERS

(Applies to fryers installed on or after November 1, 1994, only.)

1. Frymaster L.L.C. warrants the combustion chambers against defective material or workmanship for a period of ten years from the original installation date, parts and labor.
2. The combustion chamber consists of the infrared burners and the structural components to mount the burners. This warranty does not cover ancillary components, including the igniter, blower, high-limit thermostat, and temperature probe.
3. This warranty is limited to fryers operating on natural or propane (LP) gas.

D. WARRANTY PROVISIONS - COOKING COMPUTER

1. Frymaster L.L.C. warrants the M-2000 Cooking Computer against defective material or workmanship for a period of three years from the original installation date. If the unit fails within the first year, warranty will cover part and labor. If the part fails the second year, warranty will cover part only. Labor is charged to the store. The third year, warranty will cover the part at a reduced cost of \$90.00. No labor or handling will be covered.
2. During this warranty period, Frymaster will replace a returned defective cooking computer with a new or factory rebuilt and functionally operative units.
3. For replacement of defective computers under warranty, call your local Frymaster Authorized Service Center. All computers replaced under the Frymaster exchange program only carry the remaining original warranty.

E. PARTS RETURN

All defective in-warranty parts must be returned to a Frymaster Authorized Factory Service Center within 60 days for credit. After 60 days, no credit will be allowed.

F. WARRANTY EXCLUSIONS

This warranty does not cover equipment that has been damaged due to misuse, abuse, alteration, or accident such as:

- improper or unauthorized repair (including any frypot which is welded in the field);
- failure to follow proper installation instructions and/or scheduled maintenance procedures as prescribed in your MRC cards. Proof of scheduled maintenance is required to maintain the warranty;
- improper maintenance;
- damage in shipment;
- abnormal use;
- removal, alteration, or obliteration of either the rating plate or the date code on the heating elements;
- operating the frypot without shortening or other liquid in the frypot;
- no fryer will be warranted under the ten-year program for which a proper start-up form has not been received.

This warranty also does not cover:

- transportation or travel over 100 miles/160 km (50 miles/80 km each way), or travel over two hours;
- overtime or holiday charges;
- consequential damages (the cost of repairing or replacing other property which is damaged), loss of time, profits, use or any other incidental damages of any kind.

There are no implied warranties of merchantability or fitness for any particular use or purpose.

This warranty is applicable at the time of this printing and is subject to change.

**BIPH52/55-MPH52/55
SERIES GAS FRYERS
TABLE OF CONTENTS**

CHAPTER 1: Service Procedures

1.1	Functional Description	1-1
1.1.1	The Electronic Ignition System	1-1
1.1.2	Interface Board	1-2
1.1.3	Thermostats	1-4
1.2	Accessing Fryers for Servicing	1-4
1.3	Cleaning the Gas Valve Vent Tube	1-5
1.4	Checking the Burner Manifold Gas Pressure	1-5
1.5	Measuring Flame Current	1-7
1.6	Replacing Fryer Components	1-7
1.6.1	Replacing the Controller or the Controller Wiring Harness	1-7
1.6.2	Replacing the Temperature Probe or High-Limit Thermostat	1-8
1.6.3	Replacing the Interface Board	1-9
1.6.4	Replacing an Ignition Module	1-10
1.6.5	Replacing an Ignitor Assembly	1-10
1.6.6	Replacing or Cleaning a Combustion Air Blower	1-11
1.6.7	Replacing a Gas Valve	1-14
1.6.8	Replacing a Burner Assembly	1-15
1.6.9	Replacing the Filter Motor, Filter Pump, or Filter Pump Solenoid Valve	1-16
1.6.10	Replacing the Frypot	1-17
1.6.11	Replacing Frypot Insulation and/or Upper Burner Rails	1-19
1.7	Troubleshooting and Problem Isolation	1-25
1.7.1	Ignition Failure	1-25
1.7.2	Improper Burner Function	1-26
1.7.3	Improper Temperature Control	1-28
1.7.4	Computer Malfunctions	1-28
1.7.5	Filtration Malfunctions	1-29
1.7.6	Leakage	1-30
1.8	Troubleshooting Guides	1-31
1.8.1	Troubleshooting the 24 VAC Circuit	1-33
1.8.2	Troubleshooting the Gas Valve	1-35
1.8.3	Troubleshooting the Temperature Probe	1-35
1.9	Probe Resistance Chart	1-36
1.10	Principal Wiring Connections	1-37
1.11	Wiring Diagrams	1-38
1.11.1	Main	1-38
1.11.2	Transformer / Filter Boxes	1-39
1.11.2.1	MPH152/155	1-39
1.11.2.2	BIPH252/255 and 452/455 Domestic	1-40
1.11.2.3	BIPH252/255 and 452/455 International	1-41
1.11.2.4	BIPH352/355 Domestic	1-42
1.11.2.5	BIPH352/355 International	1-39

**BIPH52/55-MPH52/55
SERIES GAS FRYERS
TABLE OF CONTENTS**

1.12	Simplified Wiring Diagrams	1-44
1.12.1	BIPH52/55 Series Full Vat.....	1-44
1.12.2	BIPH52/55 Series Dual Vat	1-45
1.12.3	BIPH52/55 Series Full Vat (Australia and Pacific Rim).....	1-46

CHAPTER 2: Parts List

2.1	Accessories	2-1
2.2	Cabinetry	2-3
2.2.1	Backs, Doors, Flue Caps, Sides, and Top Caps	2-3
2.2.2	Filter Cabinet Bases, Casters, Framing, and Related Components	2-6
2.2.3	Non-Filter Cabinet Bases, Casters, Framing, and Related Components.....	2-8
2.3	Controllers	2-10
2.4	Drain, Filtration, and Oil Return System Components	2-11
2.4.1	Filtration System Components	2-11
2.4.2	Drain Valves and Associated Components	2-13
2.4.3	Rear Flush Oil Return Line Components	2-15
2.5	Electronics and Electrical Components.....	2-17
2.5.1	Component Boxes	2-17
2.5.2	Transformer Boxes	2-19
2.5.3	High-Limit Thermostat and Temperature Probe	2-22
2.7	Frypots and Associated Components	2-23
2.7.1	Full-Vat Frypot Components.....	2-23
2.7.2	Dual-Vat Frypot Components	2-25
2.8	Gas Supply and Combustion System Components	2-27
2.9	Gas Valves and Associated Components	2-29
2.10	Wiring Assemblies and Harnesses	2-31
2.11	Miscellaneous Connectors and Terminals.....	2-35

BIPH52/55-MPH52/55 SERIES GAS FRYERS

CHAPTER 1: SERVICE PROCEDURES

1.1 Functional Description

BIPH52/55 and MPH52/55 Series gas fryers contain a welded stainless steel frypot that is directly heated by a high efficiency infrared burner system requiring approximately 43% less energy than conventional burners to cook the same volume.

Self-contained combustion chambers (referred to as “burners”) are fitted into rails attached to the sides of the frypot, one on each side. Each combustion chamber is fitted with special ceramic tiles that are heated by the burning of a forced air/gas mixture. The tiles transfer heat to the frypot by means of infrared radiation, providing much more constant and uniform heat dispersion over the surface of the frypot than do conventional burners. Because less heat is lost to the atmosphere in the process, compared to “open-burner” designs, less fuel is required to achieve and maintain a given frypot temperature.

In full-vat units, gas flow to both of the burners is regulated by one electromechanical gas valve. In dual-vat units, each burner has its own valve. All fryers in this series are equipped with 24 VAC gas valve systems, and all are configured with electronic ignition.

1.1.1 The Electronic Ignition System

An ignition module mounted in the component box (located behind the control panel) is connected to an ignitor assembly at the burner. The ignition module performs four important functions: it provides fuse protection for the 24-volt circuit, provides an ignition spark, supplies voltage to the gas valve, and proofs the burner flame. The module contains a 4-second time delay circuit and a coil that activates the gas valve. Three types are in use. A closed-box design is used in most fryers, but in some fryers built for export the module resembles an interface board. A single dual-spark module is used on current production full-vat fryers. All dual-vat fryers use two single-spark modules.

The ignitor assembly consists of a spark plug, an enrichment tube, and a flame sensor.

At start-up, the power switch is placed in the ON position, supplying approximately 12-volts DC to the heat-control circuitry in the controller or computer and to one side of the heat relay coils on the interface board. If resistance in the temperature probe indicates the temperature in the frypot is below 180°F (82°C), the current flows through a melt cycle circuit where a timer switch alternately closes for 6 seconds and opens for 24 seconds. If the temperature is 180°F (82°C) or above, the current flows through a heat circuit, bypassing the timer switch. In either case, ground is supplied to the other leg of the heat relay coils, which then close electronic switches in the 24 VAC circuit to

Inside the Ignition Module

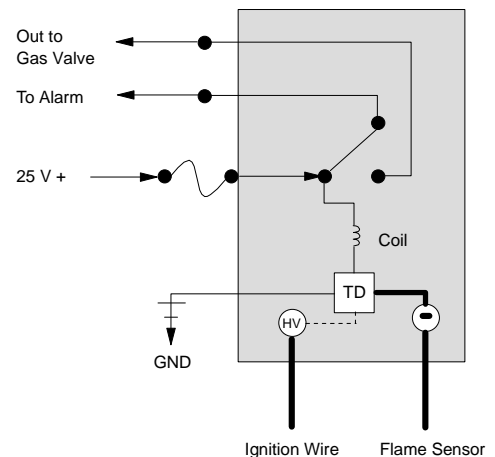

provide current to the ignition module. Circuitry in the ignition module sends 24 VAC to the gas valve via a normally closed high-limit switch (and, in fryers with built-in filtration systems, a normally closed drain safety switch). Simultaneously, the module causes the ignitor to spark for 4 seconds to light the burner. A flame sensor verifies the burner ignition by measuring the flow of microamps through the flame. If the burner does not light (or is extinguished), current to the ignition module is cut, the gas valve closes, and the ignition module “locks out” until the power switch is turned off and then back on. A probe monitors the temperature in the frypot. When the programmed setpoint temperature is reached, resistance in the probe causes the heat cycle circuitry in the controller to cut off current flow through the heat relay. This in turn cuts off the 24 VAC to the ignition module, causing the gas valve to close.

1.1.2 Interface Board

All fryers in this series have an interface board located in the component box behind the control panel. The interface board provides a link between the controller/computer and the fryer’s individual components without requiring excessive wiring, and allows the controller to execute commands from one central point. This standard interface board is also used in a number of fryer types besides the BIPH52/55 and MPH52/55 Series. **The information contained in this section applies to BIPH52/55 and MPH52/55 Series applications ONLY.**

K2 and K3 are double-pole-double throw (dpdt) relays that supply 24VAC to the ignition and gas valve circuits, as well as 120VAC to the blower motor. The relays on this board plug into sockets. If a relay fails, that relay can be replaced.

LEDs (labeled D1 through D7) are arrayed around the board to assist in troubleshooting.

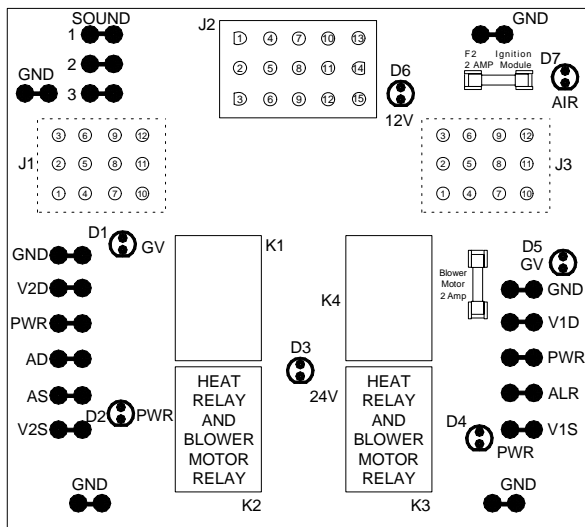

INTERFACE BOARD P/N 106-0386SP

INTERFACE BOARD LED DIAGNOSTIC LIGHTS	
D1	24 VAC to left gas valve (dual vat only)
D2	24 VAC to left ignition module
D3	24 VAC from transformer
D4	24 VAC to right ignition module
D5	24 VAC to gas valve (right valve if dual vat)
D6	12 VAC from transformer
D7	CE and Japanese units only: air switch closed

NOTE: Although the printing on some boards may indicate 2 Amp fuses, 3 Amp fuses (P/N [807-3843](#)) must be used. In full-vat fryers, the relay for the left side (K2) may not be present.

The chart on the following page illustrates current flow through the board, and the table at the top of page 1-4 identifies frequently used test points.

INTERFACE BOARD

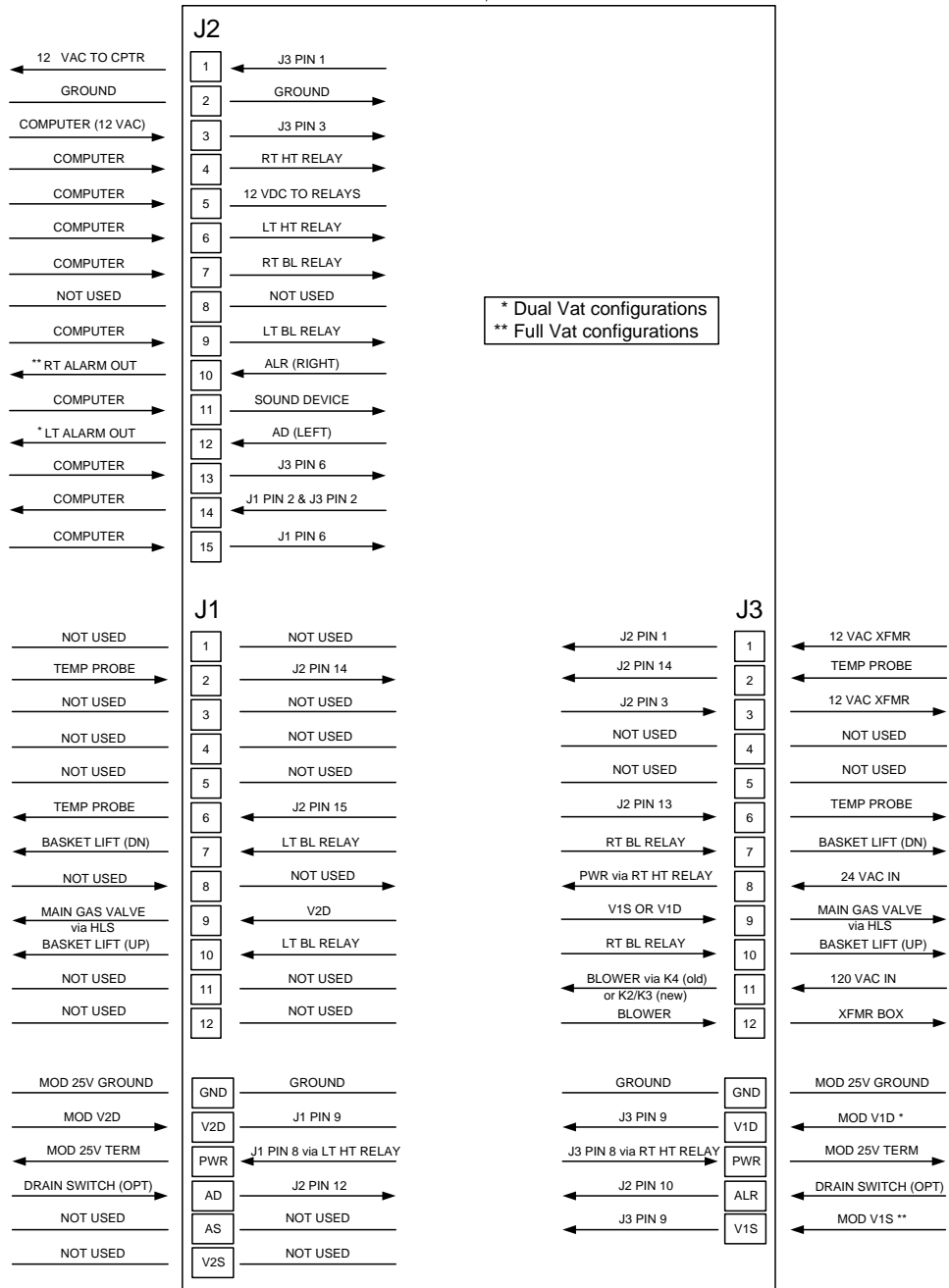

LEFT VAT

FULL OR RIGHT VAT

CURRENT FLOW THROUGH INTERFACE BOARD 106-0386SP (BIPH52/55 and MPH52/55 SERIES APPLICATION)

FREQUENTLY USED TEST POINTS FOR INTERFACE BOARD 106-0386SP			
Test	Meter Setting	Pins	Results
12VAC Power to Controller	50VAC Scale	1 and 3 on J3 or J2	12-18
24VAC Power to Right Module	50VAC Scale	8 on J3 and GROUND	22-28
120 VAC Power	250VAC Scale	11 on J3 and GROUND	110-125
120 VAC Power to Blowers	250VAC Scale	12 on J3 and GROUND	110-125
24VAC Power to Full- or Right-vat High-Limit	50VAC Scale	9 on J3 and GROUND	22-28
24VAC Power to Left High-Limit (if present)	50VAC Scale	9 on J1 and GROUND	22-28
Probe Resistance (Full- or Right-vat) *	R x 1000 OHMS	2 and 6 on J3 or 13 and 14 on J2	**
Probe Resistance (Left - if present) *	R x 1000 OHMS	2 and 6 on J1 or 14 and 15 on J2	**
Probe Isolation	R x 1000 OHMS	6 on J1 or J3 and GROUND	***
High-Limit Continuity (Full- or Right-vat)	R x 1 OHM	9 on J3 and Wire 13C on Gas Valve	0
High-Limit Continuity (Left - if present)	R x 1 OHM	9 on J1 and Wire 12C on Gas Valve	0
* Disconnect 15-pin harness from controller before testing probe circuit.			
** See Probe Resistance Chart at end of chapter.			
*** 5 mega-Ohms or greater.			

1.1.3 THERMOSTATS

BIPH52/55 and MPH52/55 Series gas fryers have *temperature probes* located on the front centerline of each frypot (dual-vat frypots have two probes, one in each vat). In this type of thermostat, the probe resistance varies directly with the temperature. That is, as the temperature rises, so does resistance, at a rate of approximately 2 ohms for every 1° F. Circuitry in the controller monitors the probe resistance and controls burner firing when the resistance exceeds or falls below programmed temperatures (setpoints). The temperatures are programmed by means of a keypad on the face of the controller.

BIPH52/55 and MPH52/55 Series fryers are also equipped with a *high-limit thermostat*. In the event that the fryer fails to properly control the oil temperature, the high-limit thermostat prevents the fryer from overheating to the flash point. The high-limit thermostat acts as a normally closed power switch that opens when exposed to temperatures above 425°F to 450°F (218°C to 232°C). The different types of thermostats have different part numbers for CE and Non-CE models, and are not interchangeable.

1.2 Accessing Fryers for Servicing

DANGER

Moving a fryer filled with oil may cause spilling or splattering of the hot liquid. Follow the draining instructions in Chapter 4 of the BIPH52/55-MPH52/55 Installation and Operation manual (P/N 819-6087) before attempting to relocate a fryer for servicing.

1. Shut off the gas supply to the unit. Unplug the power cords. Disconnect the unit from the gas supply.

2. Remove any attached restraining devices and relocate the fryer for service accessibility.
3. After servicing is complete, reconnect the unit to the gas supply, reattach restraining devices, and plug in the electrical cords. **NOTE: To ensure the safe and efficient operation of the fryer and hood, the electrical plug for the 120-volt line, which powers the hood, must be fully engaged and locked in its pin and sleeve socket.**

1.3 Cleaning the Gas Valve Vent Tube

1. Set the fryer power switch and the gas valve to the OFF position.
2. Carefully unscrew the vent tube from the gas valve. **NOTE:** The vent tube may be straightened for ease of removal.
3. Pass a piece of ordinary binding wire (.052 inch diameter) through the tube to remove any obstruction.
4. Remove the wire and blow through the tube to ensure it is clear.
5. Reinstall the tube and bend it so that the opening is pointing downward.

1.4 Checking the Burner Manifold Gas Pressure

1. **On non-CE fryers only** ensure that the gas valve knob is in the OFF position.

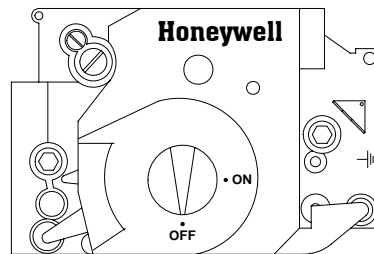

2. Remove the pressure tap plug from the gas valve assembly.

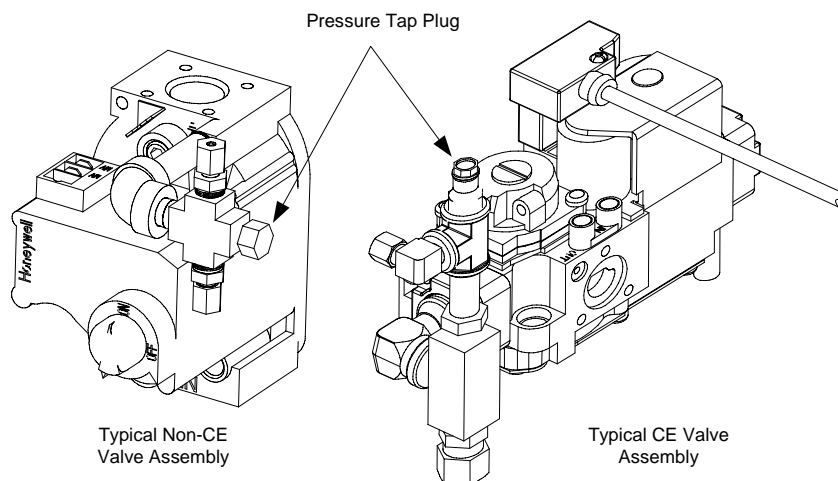

3. Insert the fitting for a gas pressure-measuring device into the pressure tap hole.
4. **On non-CE fryers only**, place the gas valve in the ON position.
5. Place the fryer power switch in the ON position. When the burner has lit and burned steadily for at least one minute, compare the gas pressure reading to the pressure for the corresponding gas in the appropriate table below. The tables list the burner manifold gas pressures for each of the gas types that can be used with this equipment.

CE Standard Burner Manifold Gas Pressures		
Gas	Pressure (mbar)	
	Single Vat	Dual Vat
Natural Gas Lacq (G20) under 20 mbar	7	7
Natural Gas Gronique * (G25) under 25 mbar	10	10
Natural Gas Gronique (G25) under 20 mbar	10	10
Butane/Propane (G30) at 28/30 or 50 mbar	17	17
Propane (G31) under 37 or 50 mbar	20	20

* Belgian G25 = 7,0 mbar (single or dual)

Non-CE Standard Burner Manifold Gas Pressures	
Gas	Pressure
Natural	3" W.C. 0.73 kPa
Propane	8.25" W.C. 2.5 kPa

6. To adjust the burner gas pressure, remove the cap from the gas valve regulator and adjust to the correct pressure.

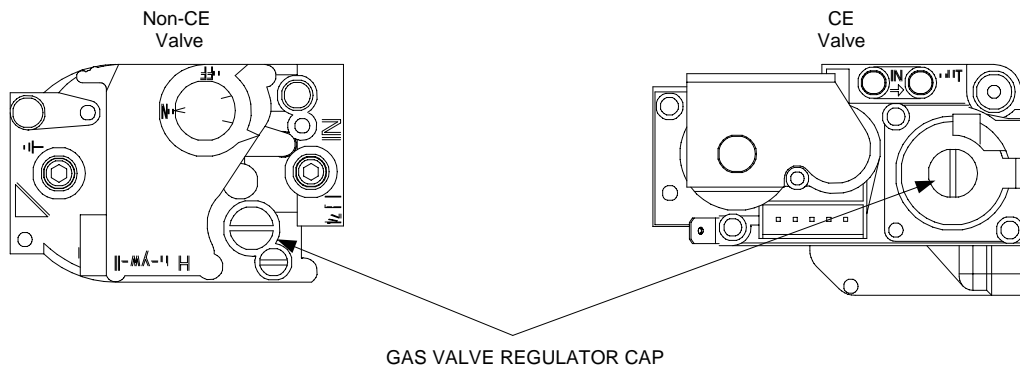

7. Place the fryer power switch (and the gas valve in non-CE fryers) in the OFF position. Remove the fitting from the pressure tap hole and reinstall the pressure tap plug.

1.5 Measuring Flame Current

When the burner flame is properly adjusted, it will produce a current between 2.5 μA and 3.5 μA . Flame current is measured by placing a *microamp* (not milliamp) meter in series with the sensing wire on the ignitor. This is accomplished as follows:

1. Place the fryer power switch in the OFF position.
2. Disconnect the sensing wire from one of the burner ignitors and connect it to the positive lead of the meter. Connect the negative lead of the meter to the terminal from which the sensing wire was removed.

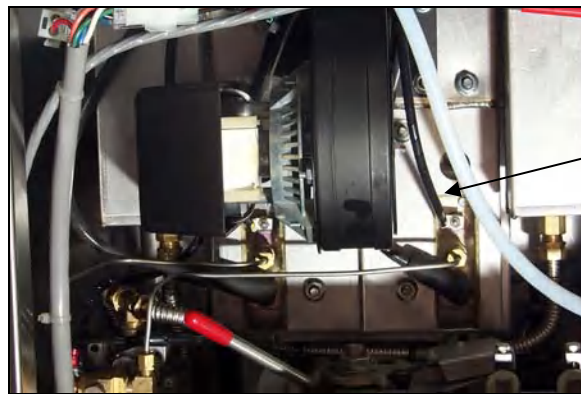

3. Place the fryer power switch in the ON position to light the burners. After the frypot temperature reaches 200°F (93°C), wait at least one minute before checking the reading. **NOTE:** The closer the unit is to normal operating temperature, the more accurate the reading will be.

1.6 Replacing Fryer Components

1.6.1 Replacing the Controller or the Controller Wiring Harness

1. Disconnect the fryer from the electrical power supply.
2. The controller bezel is held in place by tabs at the top and bottom. Slide the bezel up to disengage the lower tabs. Then slide the bezel down to disengage the upper tabs.
3. Remove the top two screws in the upper corners of the control panel.
4. Hinge the controller down. Allow it to rest on its hinge tabs to access the 15-pin connector on the back.
5. Disconnect the 15-pin wiring harness from the back of the controller and, if replacing the harness, disconnect it from the interface board.
6. Use a 5/16" nut driver (P/N 802-0352) to remove the nut and green ground wire from the back of the controller.

7. Remove the controller by lifting it up and out from the hinge slots in the control panel frame.
8. Re-hinge the NEW controller by inserting the tabs on the bottom into the slots on the control panel frame and allow it to rest on the hinge tabs.
9. If replacing the 15-pin connector, do so now. Plug the new 15-pin wiring harness into the interface board ensuring the black ferrite metal ring is on the controller-end of the wire harness.
10. Connect the 15-pin connector and the green ground wire to the new controller. When the connector is completely engaged, the clips on either side of the connector will snap into place.
11. Move the controller into the closed position against the control panel frame and replace the screws in the top corners.
12. Insert the top tabs on the bezel into the slots on the underside of the top cap. Slide the bezel down to engage the lower tabs in the lower slots.

1.6.2 Replacing the Temperature Probe or High-Limit Thermostat

1. Disconnect the fryer from the electrical supply.
2. Drain cooking oil below the level of the probe or thermostat.
3. Lift up on the bezel to disengage the tabs on its lower edge from the control panel frame.
4. Remove the top two screws in the upper corners of the control panel.
5. Swing the controller out from the top and allow it to rest on its hinge tabs.
6. Disconnect the controller wiring harness and ground wire from the back of the controller and remove the controller by lifting it from the hinge slots in the control panel frame.
7. If the fryer has a built-in filtration system, remove the clevis securing the oil return handle to the oil return operating rod and separate the rod from the handle.
8. Disconnect the ignition cables from the ignitors by grasping the boots and gently pulling toward you.
9. Disconnect the flame sensor wires from the flame sensors.
10. Disconnect the sound device lead from the interface board.
11. If working on the left frypot, cut the wire tie on the wiring bundle and disconnect the main wiring harness 15-pin connector.
12. Remove the component box mounting screws.

13. Rotate the top of the component box out of the frame and carefully pull it out enough to disconnect the wiring harness plug from the back of the box. If the unit is equipped with built-in filtration, disconnect the wires from the filter switch. This will leave one set of wires, enclosed in spiral wrap, connected to the component box.
14. Remove the box and set it atop the fryer to expose the temperature probe and high-limit thermostat.
15. Cut the leads of the probe or thermostat, as appropriate, near the component and unscrew it from the frypot.
16. Apply Loctite[®] PST56765 pipe thread sealant or equivalent to the replacement part threads and screw the replacement part into the frypot, torquing to 180 inch-pounds.
17. Unscrew and remove the temperature probe (or high-limit thermostat) from the frypot.
18. Connect the wires from the new component as follows:
 - a. If replacing the temperature probe, use a pin pusher to disconnect (one at a time) the red and white leads from the connector and insert the corresponding leads from the new probe.
 - b. If replacing the high-limit thermostat, use a pin pusher to disconnect the lead running to the connector and insert the corresponding lead from the new thermostat. Disconnect the other lead from the drain safety switch and connect the remaining lead from the new thermostat.
19. Reverse steps 1 through 14 to complete the procedure.

1.6.3 Replacing the Interface Board

1. Disconnect the fryer from the electrical power supply.
2. The controller bezel is held in place by tabs at the top and bottom. Slide the bezel up to disengage the lower tabs. Then slide the bezel down to disengage the upper tabs.
3. Remove the top two screws in the upper corners of the control panel.
4. Hinge the controller down. Allow it to rest on its hinge tabs to access the 15-pin connector on the back.
5. Disconnect the 15-pin wiring harness from the back of the controller and from the interface board.
6. Use a 5/16" nut driver (P/N 802-0352) to remove the nut and green ground wire from the back of the controller.
7. Remove the controller by lifting it up and out from the hinge slots in the control panel frame.
8. Disconnect the wires attached to the interface board, marking or making a note of the wires and terminals to facilitate reconnection.

9. Remove the nuts at each corner of the interface board and carefully pull it from the studs far enough to allow the connector on the back of the board to be disconnected, then remove the board from the box. When removing the board, be careful not to lose the spacers that fit over the studs behind the board.
10. Recover the relay(s) from the failed interface board and install on the replacement board.
11. Reverse the procedure to install the replacement board, being sure that the spacers behind the board are in place.

1.6.4 Replacing an Ignition Module

1. Disconnect the fryer from the electrical supply.
2. Lift up on the bezel to disengage the tabs on its lower edge from the control panel frame.
3. Remove the top two screws in the upper corners of the control panel.
4. Swing the controller out from the top and allow it to rest on its hinge tabs.
5. Disconnect the wires from the ignition module, marking or making a note of the wires and terminals to facilitate reconnection.
6. Remove the four ignition module screws and pull the module from the component box.
7. Move the spacers to the new module.
8. Reverse the procedure to install the replacement module.

1.6.5 Replacing an Ignitor Assembly



Drain the frypot or remove the handle from the drain valve before proceeding further.

1. Disconnect the fryer from the electrical supply.
2. Disconnect the flame sensor wire by carefully pulling its push-on terminal from the terminal strip on the ignitor. Disconnect the gas enrichment tube at the ignitor-end compression fitting. Disconnect the ignition cable from the ignitor by grasping its boot and gently pulling toward you. (See photo on the following page)

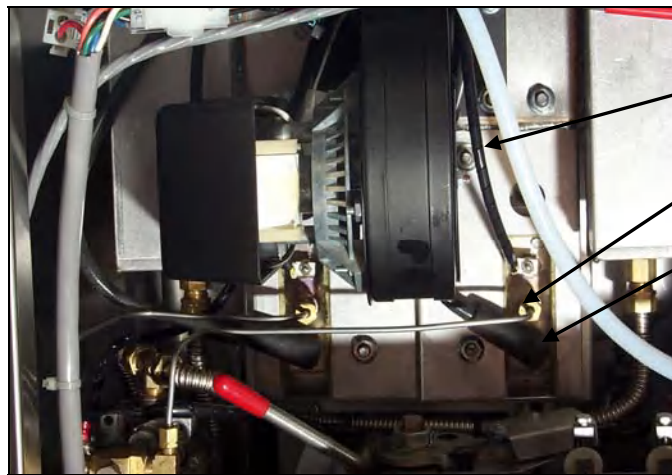

3. Remove the sheet metal screws securing the ignitor to the mounting plate and pull the ignitor from the fryer.
4. Reverse the procedure to install the replacement ignitor.

1.6.6 Replacing or Cleaning a Combustion Air Blower

1. Disconnect the blower wiring harness, remove the blower assembly mounting nuts, and remove the blower assembly from the fryer. If cleaning the motor, continue with Step 2; otherwise, install the replacement blower, reconnect the wiring harness, and then go to Step 6.

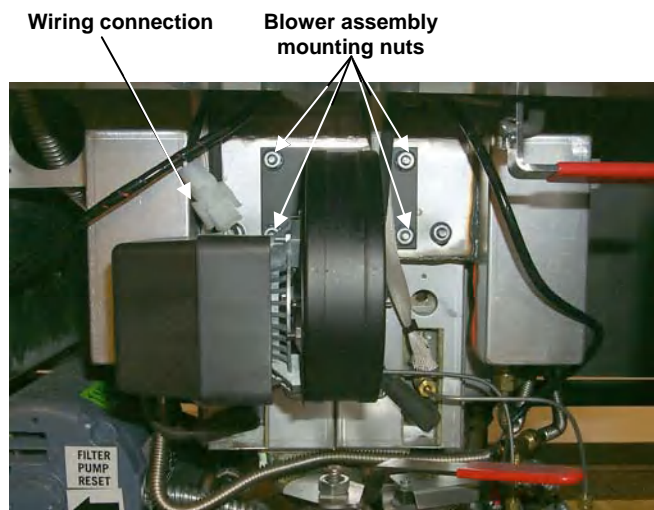

2. Remove the blower motor shield and separate the blower motor from the housing as shown in the illustration on the following page.

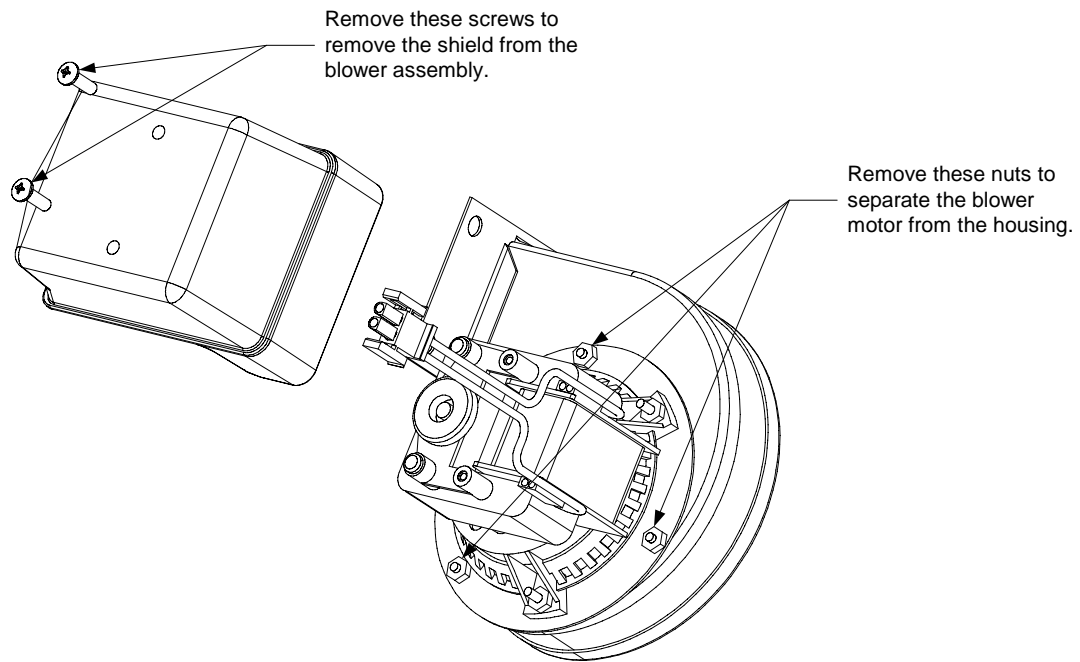

3. Wrap the motor with plastic wrap to prevent water from entering it. Spray degreaser or detergent on the blower wheel and the blower housing. Allow it to soak for five minutes. Rinse the wheel and housing with hot tap water, then dry with a clean cloth.

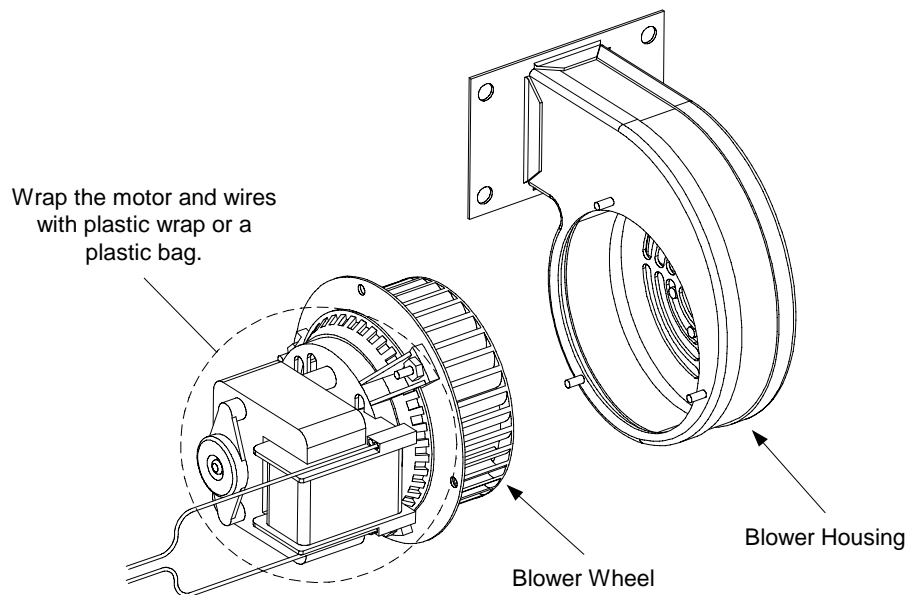

4. Remove the plastic wrap from the blower motor assembly. Reassemble the blower motor assembly and blower housing. Reinstall the blower shield.
5. Reinstall the blower assembly in the fryer and reconnect the wiring disconnected in Step 1.
6. Light the fryer in accordance with the procedure described in Chapter 3, Section 3.1.2 of the BIPH52/55-MPH52/55 Series Gas Fryer Installation and Operation Manual (P/N 819-6087).

7. After the burners have been lit for at least 90 seconds, observe the flames through the burner viewing ports located on each side of the combustion air blower.

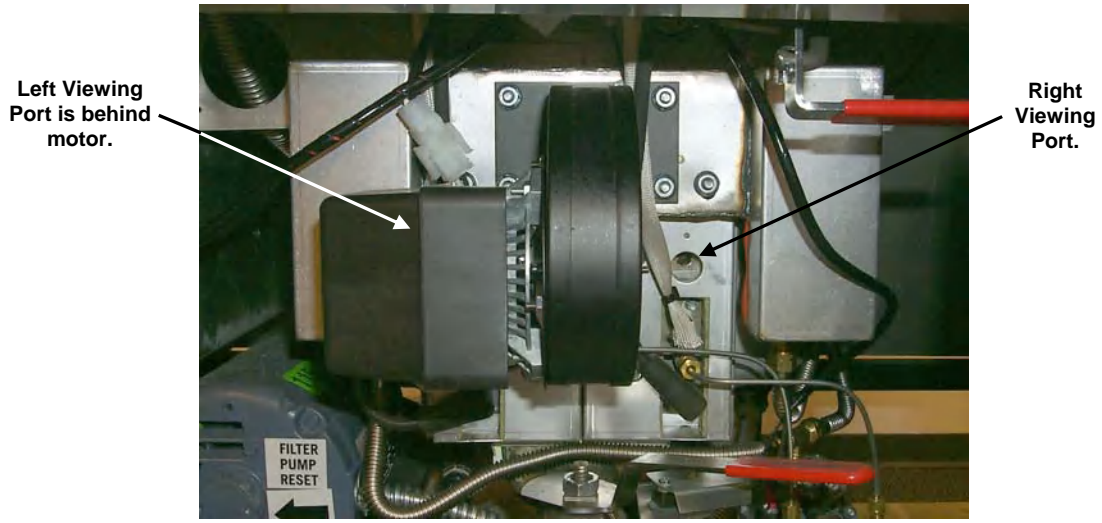

The air/gas mixture is properly adjusted when the burner manifold pressure is in accordance with the applicable table on page 1-6 and the burners display a bright orange-red glow. If a blue flame is observed or if there are dark spots on a burner face, the air/gas mixture requires adjustment.

Adjusting the Air/Gas Mixture

On the side of the blower housing opposite the motor is a shutter plate with a locking nut. Loosen the nut enough to allow the shutter to be moved, then adjust the position of the shutter to open or close the air intake opening until a bright orange-red glow is obtained. Carefully hold the shutter in position and tighten the locking nut.

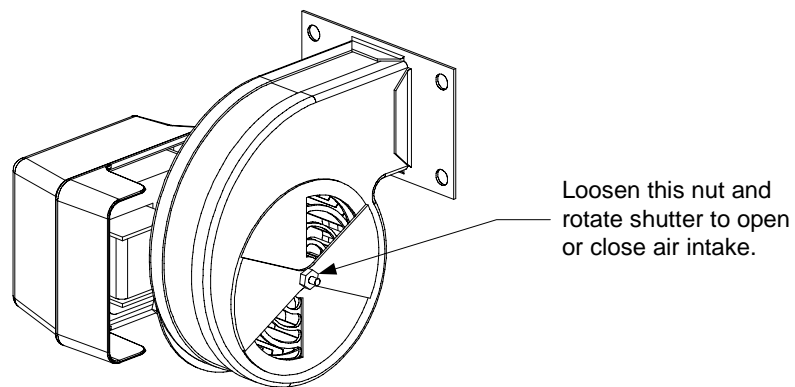

1.6.7 Replacing a Gas Valve



Drain the frypot or remove the handle from the drain valve before proceeding further.

1. Disconnect fryer from electrical and gas supplies.
2. Disconnect the drain safety and high-limit thermostat wires from the gas valve. Mark each wire to facilitate reconnection.
3. Remove the vent tube (on non-CE fryers) and the enrichment tube fitting from the valve. Disconnect the flexible gas line(s).

If replacing the left-most valve on any configuration, or the right valve on a two-fryer battery, follow the instructions below. If replacing valves in other positions, skip to “ALL OTHER VALVES.”

- A. Remove the filter pan from the unit. Remove the door adjacent to the valve being replaced.
- B. Remove the five screws on the front face of the pan rail assembly adjacent to the valve being replaced. Remove the nut and bolt securing the rear end of the rail to the cabinet.
- C. Remove the two nuts and bolts immediately behind the front face of the pan rail assembly. Pull the assembly from the unit to gain access to the pipe union on the gas line.
- D. Uncouple the pipe union and remove the gas valve and associated piping from the unit.
- E. Remove the fittings and associated piping from the failed valve and install them on the replacement valve using Loctite[®] PST56765 or equivalent pipe thread sealant.
- F. Reconnect the gas valve assembly to the fryer using Loctite[®] PST56765 or equivalent pipe thread sealant, and reattach the flexible gas line(s), enrichment tube(s), and the vent tube (on non-CE units). Reconnect the high-limit thermostat wires and drain safety wires to the valve.
- G. Reconnect the fryer to the gas supply and open the cut off valve. Apply a solution of soapy water around each connection to check for gas leaks. Eliminate any that are found.
- H. Position the pan rail assembly beneath the fryer and rest the rear end of the rail on the cabinet frame. Install the two nuts and bolts behind the front face of the rail, but do not tighten them. Install the nut and bolt at the rear end of the filter rail and tighten securely.
- I. Install the five screws in the front face of the rail, but do not tighten them. Install the filter pan in the unit to make sure that all components are properly aligned; then, securely tighten the remaining bolts and screws.
- J. Reconnect the fryer to the electrical power supply and check for proper operation. When proper operation has been verified, reinstall the door removed in Step A.

ALL OTHER VALVES

4. Carefully unscrew the valve from the manifold. **NOTE:** Some models may have the valve attached to the manifold by means of a pipe union. In such cases, remove the valve by uncoupling the union.
5. Remove all fittings from the old gas valve and install them on the replacement valve, using Loctite® PST56765 or equivalent pipe thread sealant.
6. Reconnect the gas valve assembly to the fryer using Loctite® PST56765 or equivalent pipe thread sealant, and reattach the flexible gas line(s), enrichment tube(s), and the vent tube (on non-CE units). Reconnect the high-limit thermostat wires and drain safety wires to the valve.
7. Reconnect the fryer to the gas supply and open the cut off valve. Apply a solution of soapy water around each connection to check for gas leaks. Eliminate any that are found.
8. Reconnect the fryer to the electrical power supply and check for proper operation.

1.6.8 Replacing a Burner Assembly



Drain the frypot or remove the handle from the drain valve before proceeding further.

1. Disconnect the unit from the electrical and gas supplies.
2. Remove the combustion air blower per the procedure found in Section 1.6.6.
3. Remove the four nuts from the air plenum assembly and pull the assembly straight out toward you until it clears the burner tubes.

NOTE: On a dual-vat fryer, it will be necessary to remove the drain valve handles before the plenum can be removed.

NOTE: If the flexible oil return lines are blocking the plenum, carefully bend them upward enough to clear the plenum.

4. Disconnect the ignition cable from the ignitor by grasping its boot and pulling gently toward you. Disconnect the flame sensor wire from the ignitor by gently pulling its push-on terminal from the terminal strip on the ignitor.
5. Disconnect the flexible gas lines from the burner orifice and the enrichment tube from the ignitor assembly.
6. Remove the four ¼-inch nuts securing the outer front covers to the frypot assembly.
7. Remove the sheet metal screws at the top of the outer front covers and pull the covers straight out toward you until clear of the mounting studs.

8. Remove the washers and tubular spacers from the mounting studs, then pull the inner covers straight out toward you until clear of the mounting studs.
9. Grasp the burner firmly and pull it toward you until it clears the burner channels, taking care not to damage the ceramic tiles in the process.
10. Clean all debris from the burner channels and combustion area.
11. Inspect the upper and lower burner rails for cracked or burned out welds.
 - a. If the welds in the lower rail are cracked or burned out, the frypot must be replaced. Refer to Section 1.6.10 for procedure.
 - b. If the welds in the upper rail are cracked or burned out, the upper rail must be replaced. Refer to Section 1.6.11 for procedure.
12. Place a new insulating strip along the top, rear, and bottom edge of the burner and carefully slide it straight into the rails. **NOTE:** Use P/N [826-0931](#) for full-vat frypots and P/N [826-0932](#) for dual-vat frypots.
13. Reverse steps 1 through 9 to reassemble the components.
14. Fill the frypot with oil. Turn the fryer on, turn off or bypass the melt cycle, and operate the unit for at least 10 minutes.
15. Visually examine the burner flame. The color and intensity on both sides should be the same.
16. Use an inspection mirror to check for leaks in areas that cannot be directly observed.
17. If a leak is detected, tighten all the lower insulation retainer nuts, allow the frypot to run for five additional minutes, and repeat steps 15 and 16.
18. If the leak persists, use a rubber hammer and a small block of wood to tap the corners of the lower combustion chamber insulation retainers. Repeat steps 15 through 17. **Repeat this step until no leakage is detected.**

1.6.9 Replacing the Filter Motor, Filter Pump, or Filter Pump Solenoid Valve

1. Disconnect the unit from the electrical power supply.
2. Remove the filter pan from the unit and drain the frypots into a Shortening Disposal Unit (SDU) or other appropriate metal container.



DANGER

DO NOT attempt to drain more than one full frypot or two split frypots into the SDU at one time.

3. Position a container beneath the oil return fitting at the front of the cabinet. Disconnect the flexible oil line from the fitting, allowing any residual oil to drain into the container.
4. At the rear of the fryer, unplug the left connector (as viewed from the rear of the fryer) from the transformer box. Using a pin pusher, push the pump solenoid valve wires from Pins 7 and 9.
5. Remove the four nuts and bolts attaching the motor mount to the rear motor mount support.
6. At the front of the fryer, remove the cover plate from the front of the motor and disconnect the motor wires.
7. Place a 1-foot (30.5-cm) length of wood (or similar support) beneath the motor mount near the front of the unit and remove the two remaining nuts and bolts attaching the motor mount to the front cabinet cross-brace.
8. Carefully remove the support and lower the motor mount to the floor, allowing the rear of the mount to slide forward and off the rear motor mount support.
9. Disconnect the return flexline from the pump. The motor and pump assembly can now be pulled from beneath the fryer and the failed component can be removed and replaced.
10. Position the new/repaired motor and pump assembly beneath the fryer and reconnect the oil return flexline to the pump. Lift the rear of the motor mount up and onto the rear motor mount support.
11. Lift the front of the motor mount up and support it with a 1-foot (30.5-cm) piece of wood or a similar support. Install but do not tighten the two nuts and bolts that attach the motor mount to the front cabinet cross-brace.
12. Install and tighten the four nuts and bolts that secure the motor mount to the rear motor mount support. Reconnect the solenoid valve wires to Pins 7 and 9 of the 9-pin connector (polarity does not matter) and reconnect the plug.
13. At the front of the fryer, tighten the two nuts and bolts at the front of the motor mount. Reconnect the motor power wires and reinstall the wiring cover plate.
14. Reconnect the oil return flexline and reinstall the filter pan.
15. Reconnect the unit to the electrical power supply, fill the frypots with oil and check for proper operation.

1.6.10 Replacing the Frypot

1. Disconnect the fryer from the electrical and gas supplies.

2. Remove the filter pan from the unit and drain one frypot at a time into a Shortening Disposal Unit (SDU) or other appropriate metal container.



DO NOT attempt to drain more than one full frypot or two split frypots into the SDU at one time.

3. Dismount the topcap by removing the screws on the bottom of each front corner and lifting the topcap straight up.
4. Remove the bezels by lifting them up to disengage the tabs along the lower edges from the slots in the control panel frame. Remove the top two screws in the upper corners of the control panel.
5. Grasp the upper edge of each controller and swing the controller downward. Unplug the controller wiring harness and grounding wire from the back of each controller.
6. Remove the controllers by lifting them from the hinge slots in the control panel frame.
7. Remove the clevis that secures the oil return rod to the oil return handle and separate the rod and handle. **NOTE:** On split-vat units, there are two oil return handles.
8. Disconnect the sound device wire from the interface board and disconnect the oil return switch wires from the switch terminals.
9. Disconnect the flame sensor wires by carefully pulling the push-on terminals from the terminal strips on the ignitors. Disconnect the gas enrichment tube at the ignitor-end compression fitting. Disconnect the ignition cables from the ignitors by grasping the boots and gently pulling toward you.
10. Remove the two mounting screws on each side of the component box and rotate the top of the box out of the frame. Carefully pull it out enough to disconnect the wiring harness connector from the back of the box. Cut any ties that prevent the box from being pulled out of the control panel frame.
11. Carefully pull the box clear of the frame and rest it atop the fryer.
12. Using a pin pusher, remove the temperature probe and high-limit thermostat wires from the plugs or terminals, marking each wire to facilitate re-assembly.
13. Remove the cover from the safety drain switch. Disconnect the wires from the switch.
14. Remove the section(s) of drain from the drain valve(s) of the frypot to be removed.
15. Disconnect the gas lines from the burner orifices and ignitor assemblies.
16. Remove the frypot hold down bracket.

17. Remove the screws in the back panel and inside the flue cap at each end that secure the flue cap to the fryer and lift it clear of the fryer.
18. Disconnect the oil return line(s) from the frypot to be removed.
19. Carefully lift the frypot from the fryer cabinet.
20. Remove the drain valve(s), temperature probe(s), high-limit thermostat(s), and ignitor assemblies. Inspect each of these components carefully and install them in the replacement frypot if they are in serviceable condition. Use Loctite[®] PST56765 sealant or equivalent on component threads.

NOTE: Some servicers, based upon their experience, recommend that probes and thermostats be replaced whenever a frypot is replaced; however, this remains the customer's decision.
21. Reverse steps 1-19 to reassemble fryer.

NOTE: Care should be taken not to over-torque nuts on frypots made of 400-series stainless steel, as this could tear the material. One turn past hand-tight is sufficient torque.
22. Perform steps 14 through 18 of Section 1.6.8 to ensure that there are no leaks in the burner insulation.

 **CAUTION**

Before installing temperature probe, high-limit thermostat, and drain valve on replacement frypot, clean the threads and apply Loctite[®] PST56765 thread sealant or equivalent.

1.6.11 Replacing Frypot Insulation and/or Upper Burner Rails

NOTE: Replacing the burner rails requires completely tearing down the frypot and installing new frypot insulation. Refer to the frypot exploded view on page 1-21 for component identification.

1. Remove the frypot per Section 1.6.10.
2. Remove the burner assemblies (1).
3. Remove insulation retainers and blanket insulation (2).
4. Remove the upper oil zone insulation bracket and upper oil zone insulation (3).
5. Remove the plenum (4).
6. Remove the front lower combustion chamber insulation retainer and insulation (5), and the front lower combustion chamber inner insulation retainer and insulation (6). **NOTE:** Full-vat units have two-piece insulation retainer and insulation components. Dual-vat units have one-piece components.
7. Remove the upper combustion chamber insulation retainer and insulation (7).

8. Remove the inner upper combustion chamber insulation retainer and insulation (8).
9. Remove the rear lower combustion chamber retainers, back, and insulation (9). **NOTE:** Full-vat units have two-piece backs and four retainers. Dual-vat units have one-piece backs and two retainers.
10. Remove the flue assembly (10).

See Page 1-22 for Reassembly

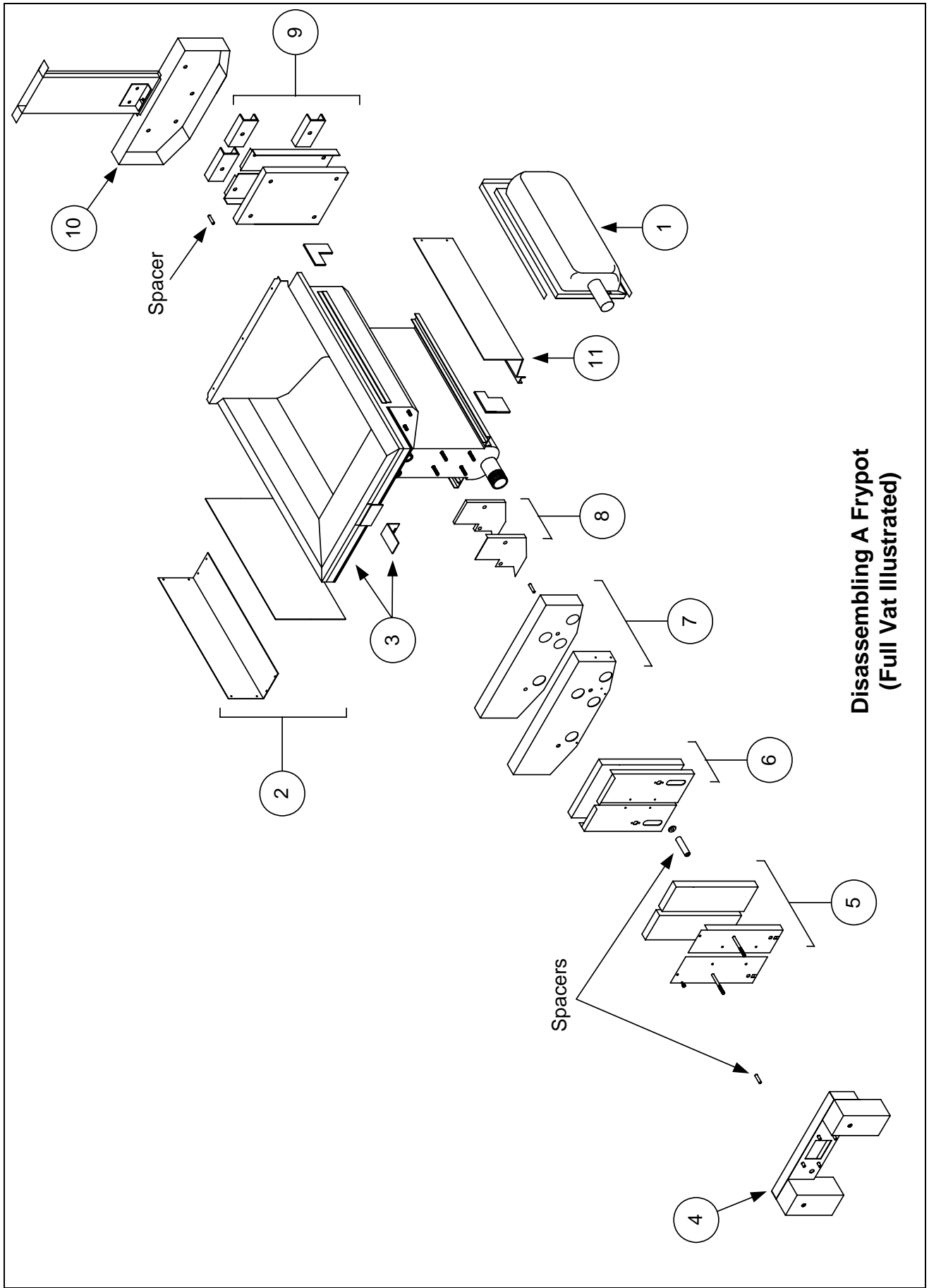

**Disassembling A Frypot
 (Full Vat Illustrated)**

11. Remove the upper burner rails (11). **NOTE:** For the following steps, refer to the frypot exploded view on page 1-24 for component identification.
12. Remove any residual insulation, sealant, and/or oil from the exterior of the frypot.
13. Place the “L” shaped pieces of the combustion chamber insulation (1) in the front and rear corners of both upper rail-retaining slots. (See page 1-24).
14. Using a mallet and short piece of wood, tap the corner tabs of the combustion chamber over the insulation to ensure a solid seal of the burner.
15. Install the upper burner rails (2) with the heat deflectors slanting toward the rear of the frypot. The rails will cover the “L” shaped pieces of combustion chamber insulation previously installed.
16. Place the upper inner combustion chamber insulation and insulation retainers (3) on the top two studs on each side of the front of the frypot and secure with ¼”-20 washer-nuts. *It is normal for the retainers to slice off the overhanging insulation.*
17. Place the lower rear combustion chamber insulation (4) on the lower four studs at the rear of the frypot.
18. Place one 1.625-inch tubular spacer (5) on each of the flue assembly (upper) studs at the rear of the frypot. **NOTE:** There are three different sizes of spacers. Verify the size to ensure the correct spacers are installed.
19. Press the flue assembly (6) over the burner rails. It may be necessary to use a rubber mallet or screwdriver to align the components. Use four ¼”-20 washer nuts to secure the flue assembly. **Do not tighten the retainer nuts at this point. They should be finger-tight only. NOTE:** The flue edge will cover one to two inches of the lower insulation.
20. Install the lower rear combustion chamber back(s) and retainer(s) (7) with the flanged edge(s) against the flue. Secure with ¼”-20 washer nuts. **NOTE:** Full-vat units have two-piece backs and four retainers. Dual-vat units come with one-piece backs and only two retainers.
21. Insert the burners (9) into the rails to ensure the rail spacing and alignments are correct. The burner should slide freely into and out of the rails. The upper rail can be bent slightly to increase or decrease tension on the burner and the edges of the slot can be closed or opened slightly to best fit the burner frame.
22. Carefully wrap a strip of burner insulation (8) tightly around the rear and sides of the burner frame (9), with the glass-tape side of the strip on the outside. **Do not use duct tape or adhesive to secure the strip to the burner frame.**
23. Align the burner to the burner rails while maintaining tension on the insulation strip. Insert the burner at a slight angle and begin pushing the burner slowly into the rails until it contacts the rear combustion chamber. The fit should be snug, but not excessively tight.

24. Verify that the burners are flush with the front edge of the burner rails. Remove the excess burner insulation by cutting with a knife or diagonal pliers. **Do not try to tear the insulation!**
25. Insert the upper front insulation (10) into its retainer (11), making sure that the holes in each piece are aligned with one another. Install the assembly with the insulation side toward the frypot and secure with ¼”-20 washer-nuts. **Do not over tighten.**
26. Place a washer on each of the four lower studs on the front of the frypot. Install the lower inner front insulation (12) with the rectangular openings toward the drain valve nipple. Install the lower inner front insulation retainer(s) (13). **NOTE:** Full-vat units have a two-piece insulation retainer. Dual-vat units have a one-piece retainer.
27. If necessary, replace the sight-glasses and insulation (14).
28. Place one washer and one 1.888-inch spacer (15) on each stud. **NOTE:** There are three different sizes of spacers. Verify the size to ensure the correct spacers are installed.
29. Insert the front lower insulation (16) into the front lower insulation retainer(s) (17) and install assembly on frypot. Secure with ¼”-20 washer-nuts. If frypot uses two retainers, connect them together with two ¼” self-tapping screws. **NOTE:** Full-vat units have a two-piece insulation retainer and two pieces of insulation. Dual-vat units have one-piece components.
30. Return to the rear of the frypot and fully tighten all washer-nuts.
31. Remove and replace the plenum gaskets (18).
32. Place a 0.938-inch spacer (19) on the plenum-mounting studs, and mount the plenum (20). Ensure the gaskets are clear of the burner tubes by pulling the plenum back slightly. Place a washer on each stud and secure plenum with ¼”-20 lock-nuts.
33. Install the upper oil-zone insulation (21) by pressing it under the upper combustion chamber metalwork. Secure the insulation with the bracket (22) and ¼” self-tapping screws.
34. Install the upper burner rail blanket insulation (23). Position any excess insulation toward the top of the frypot. Avoid overhang past the bottom of the upper burner rail. Overhang in this area will make future burner replacement more difficult.
35. Cover the insulation with the insulation retainer (24), and secure with ¼” self-tapping screws.
36. Reinstall probes, drain valves, high-limit thermostats, and other pipefittings using Loctite® PST56765 sealant or equivalent on the threads.

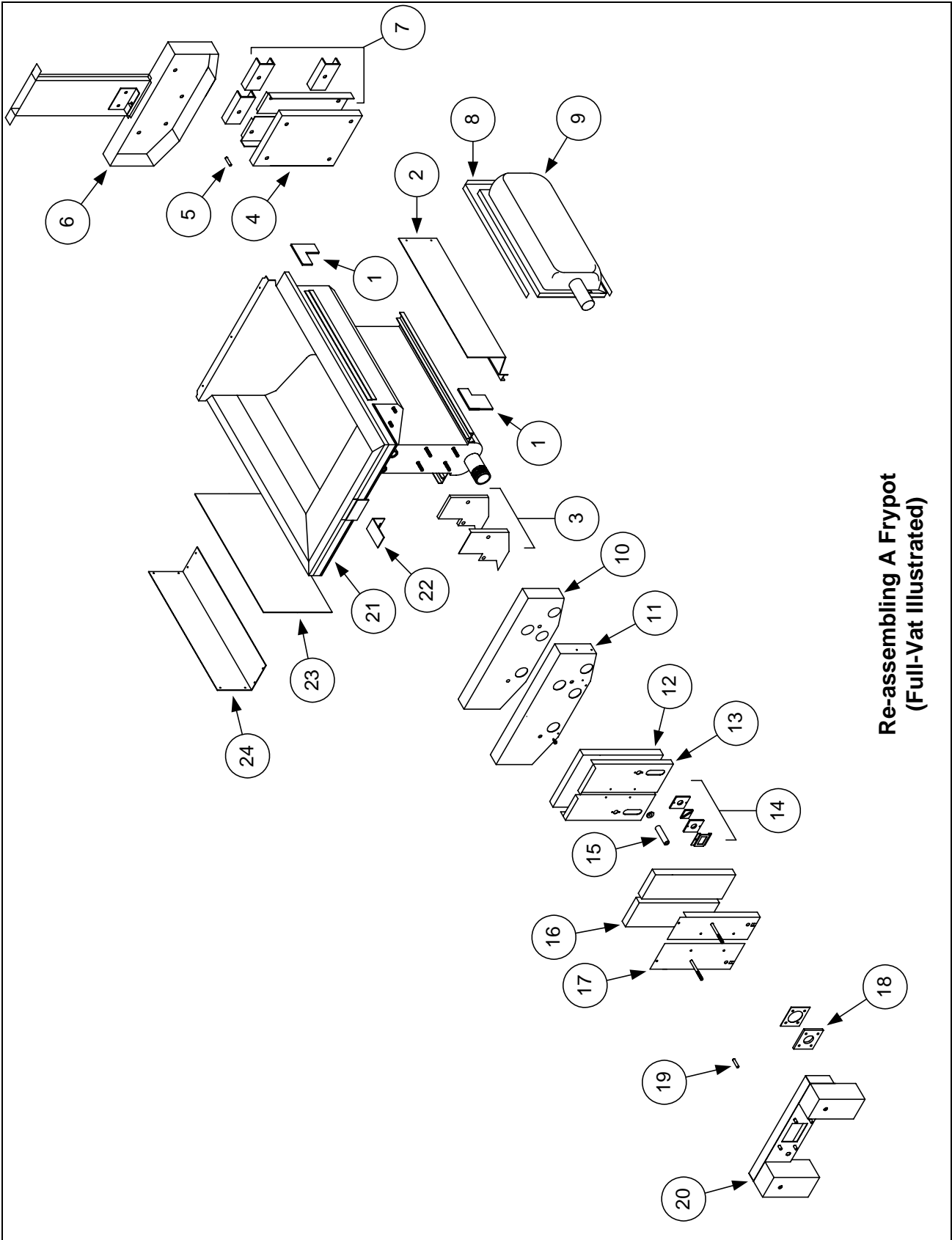

**Re-assembling A Frypot
(Full-Vat Illustrated)**

1.7 Troubleshooting and Problem Isolation

Because it is not feasible to attempt to include in this manual every conceivable problem or trouble condition that might be encountered, this section is intended to provide technicians with a general knowledge of the broad problem categories associated with this equipment, and the probable causes of each. With this knowledge, the technician should be able to isolate and correct any problem encountered.

Problems you are likely to encounter can be grouped into six categories:

1. Ignition failure
2. Improper burner function
3. Improper temperature control
4. Computer malfunctions
5. Filtration malfunctions
6. Leakage

The probable causes of each category are discussed in the following sections. A series of Troubleshooting Guides is also included at the end of the chapter to assist in solving some of the more common problems.

1.7.1 Ignition Failure

Ignition failure occurs when the ignition module fails to sense a flame within the 4-second time delay period and locks out. When this happens, the module sends 24 VAC through the interface board alarm circuit to the computer.

M2000 computers display “*IGNITION FAILURE.*”

The three primary reasons for ignition failure, listed in order of probability, are problems related to:

1. Gas and/or electrical power supplies
2. Electronic circuits
3. Gas valve.

PROBLEMS RELATED TO THE GAS AND/OR ELECTRICAL POWER SUPPLIES

The main indicators of this are that an entire battery of fryers fails to light and/or there are no indicator lights illuminated on the fryer experiencing ignition failure. Verify that the quick disconnect fitting is properly connected, the fryer is plugged in with connector twisted and locked, the main gas supply valve is open, and the circuit breaker for the fryer electrical supply is not tripped.

PROBLEMS RELATED TO THE ELECTRONIC CIRCUITS

If gas and electrical power are being supplied to the fryer, the next most likely cause of ignition failure is a problem in the 24 VAC circuit. Verify that the drain valve is fully closed. The valve is attached to a microswitch that must be closed for power to reach the gas valve (often, although the

valve handle appears to be in the closed position, the microswitch is still open). If the valve is fully closed, refer to Section 1.8.1, **TROUBLESHOOTING THE 24 VAC CIRCUIT**.

Some typical causes of ignition failure in this category include a defective sensing wire in the ignitor assembly, a defective module, a defective ignition wire, and a defective ignitor.

Occasionally you may encounter an ignition failure situation in which all components appear to be serviceable and the microamp reading is within specification, but the unit nevertheless goes into ignition failure during operation. The probable cause in this case is an intermittent failure of an ignition module. When the unit is opened up for troubleshooting, the module cools down enough to operate correctly; however, when the unit is again closed up and placed back into service the module heats up and fails.

PROBLEMS RELATED TO THE GAS VALVE

If the problem is not in the 24 VAC circuit, it is most likely in the gas valve, itself. Before replacing the gas valve, refer to Section 1.8.2 **TROUBLESHOOTING THE GAS VALVE**.

1.7.2 Improper Burner Function

With problems in this category, the burner ignites but exhibits abnormal characteristics such as “popping,” dark spots on the burner ceramics, fluctuating flame intensity, and flames shooting out of the flue.

“*Popping*” indicates delayed ignition. In this condition, the main gas valve is opening but the burner is not immediately lighting. When ignition does take place, the excess gas “explodes” into flame, rather than smoothly igniting.

The primary causes of popping are:

- Incorrect or fluctuating gas pressure
- Defective or incorrectly adjusted combustion air blower
- Inadequate make-up air
- Heat-damaged controller or ignition module
- Cracked ignitor or broken ignition wire
- Defective ignition module
- Cracked burner tile (typically causes a very loud pop).

If popping occurs only during peak operating hours, the problem may be incorrect or fluctuating gas pressure. Verify that the incoming gas pressure (pressure to the gas valve) is in accordance with the appropriate CE or Non-CE Standard found in Section 2.3 of the BIPH52/55-MPH52/55 Series Gas Fryer Installation and Operation Manual (part number 819-6087), and that the pressure remains constant throughout all hours of usage. Refer to Section 1.4, **Checking the Burner Manifold Gas Pressure** in this manual for the procedure for checking the pressure of gas supplied to the burner.

If popping is consistent during all hours of operation, the most likely cause is an insufficient air supply. Check for “negative pressure” conditions in the kitchen area. If air is flowing into the

kitchen area, this indicates that more air is being exhausted than is being replenished and the burners may be starved for air.

If the fryer's gas and air supplies are okay, the problem is most likely with one of the electrical components. Examine the ignition module and controller for signs of melting, distortion, and/or discoloration due to excessive heat build-up in the fryer (this condition usually indicates improper flue performance). A melted or distorted ignition module is automatically suspect and should be replaced; however, unless the condition causing excessive heat is corrected, the problem is likely to recur.

Verify that the ignition wire is tightly connected at both ends and free of obvious signs of damage. Again, if damage is due to excessive heat in the fryer, that problem must also be corrected. Check for proper operation by disconnecting the wire from the ignitor (spark plug), inserting the tip of a screw driver into the terminal. With the insulated handle of the screwdriver, hold the shaft near the frame of the fryer as the power switch is placed in the ON position. A strong, blue spark should be generated for at least 4 seconds.



**Make sure you are holding the insulated handle of the screwdriver and not the blade.
The sparking charge is approximately 25,000 volts.**

Examine the ignitor (spark plug) for any signs of cracking. A cracked ignitor must be replaced.

If all other causes have been ruled out, examine the burner tiles for any signs of cracking. If cracking is found, the burner must be replaced.

Fluctuating flame intensity is normally caused by either improper or fluctuating incoming gas pressure, but may also be the result of variations in the kitchen atmosphere. Verify incoming gas pressure in the same way as for "popping," discussed in the preceding paragraphs. Variations in the kitchen atmosphere are usually caused by air conditioning and/or ventilation units starting and stopping during the day. As they start and stop, the pressure in the kitchen may change from positive or neutral to negative, or vice versa. They may also cause changes in airflow patterns that may affect flame intensity.

Dark spots on the burner tiles are the result of an improper air/gas mixture. Adjust the combustion air blower to reduce the amount of air in the mixture to correct this problem

Flames shooting out of the flue are usually an indication of negative pressure in the kitchen. Air is being sucked out of the burner enclosure and the flames are literally following the air. If negative pressure is not the cause, check for high burner manifold gas pressure in accordance with the procedures in Section 1.4.

An *excessively noisy burner*, especially with *flames visible above the flue opening*, may indicate that the gas pressure is too high, or it may simply be that the gas valve vent tube is blocked. If the incoming gas pressure is correct and the vent tube is unobstructed, the gas valve regulator is probably defective.

Occasionally a burner may apparently be operating correctly, but nevertheless the fryer has a *slow recovery rate* (the length of time required for the fryer to increase the oil temperature from 270°F to

320°F (132°C to 160°C)). The primary causes of this include an over-filled frypot, a dirty or out-of-adjustment combustion air blower, low burner manifold pressure, and/or damaged burner tiles. Adding oil to the frypot during the recovery process will also cause a slow recovery rate.

If these causes are ruled out, the probable cause is a misadjusted gas valve regulator. Refer to Section 1.4, **Checking the Burner Manifold Gas Pressure**, for the gas valve adjustment procedure.

1.7.3 Improper Temperature Control

Temperature control, including the melt cycle, is a function of several interrelated components, each of which must operate correctly. The principle component is the temperature probe. Other components include the interface board, the controller itself, and the ignition module.

Improper temperature control problems can be categorized into melt cycle problems and failure to control at setpoint problems.

MELT CYCLE PROBLEMS

In fryers equipped with M2000 computers, initiation of the melt cycle is automatic. Problems may originate from the controller itself, the temperature probe, or a malfunctioning heat relay on the interface board.

FAILURE TO CONTROL AT SETPOINT

Problems in this category may be caused by the temperature probe, the interface board, or the controller.

1.7.4 Computer Malfunctions

RECOVERY TIME

Recovery time – is a method of measuring a fryer's performance. Put simply, it is the time required for the fryer to increase the oil temperature from 270°F to 320°F (132°C to 160°C). This range is used as a standard since ambient kitchen temperatures can affect the test if lower ranges are used.

The M2000 computer performs the recovery test each time the fryer warms up. An operator can view the results of the test any time the fryer is above the 325°F (163°C) point by pressing the button and entering the code 1652. The test results will be displayed in the computer's LED panel in minutes and seconds. The maximum acceptable recovery time for BIPH52/55-MPH52/55 Series gas fryers is two minutes and twenty-five seconds.

COMMON COMPUTER COMPLAINTS

Most problems concerning computers have to do with programming them. There are two common complaints:

1. Fryer constantly displays “HI.”

Cause: Setpoint is incorrect or missing.

Corrective Action: Check setpoint and refer to the M2000 computer manual for instructions to adjust the setpoint.

2. Temperature is displayed in Celsius.

Cause: Computer is programmed to display in Celsius.

Corrective Action: Turn the computer off then press 1658.

1.7.5 Filtration Malfunctions

The majority of filtration problems arise from operator error. One of the most common errors is placing the filter pad on the bottom of the filter pan rather than over the filter screen.

Whenever the complaint is “the pump is running, but no oil is being filtered,” check the installation of the filter pad, including that the correct size is being used. While you are checking the filter pad, verify that the O-rings on the filter pan suction tube are present and in good condition. Missing or worn O-rings will allow the pump to suck air and decrease its efficiency.

If the pump motor overheats, its thermal overload will trip and the motor will not start until it is reset. If the pump motor does not start, press the red reset switch located on the front of the motor. If the pump then starts, something caused the motor to overheat. It may be just that several frypots in a large battery of fryers were being filtered one after the other and the pump became hot. Letting the pump cool down for at least a half-hour is all that is required in this case. More often, the pump overheated for one of the following reasons:

- Shortening that remained in the pan after previous filtering solidified in the suction tube recess in the bottom of the pan or the suction tube, itself. Adding hot oil to the pan and waiting a few minutes will usually correct this problem. A flexible wire can be used to clean out the suction tube and the recess in the bottom of the pan. **NEVER** use compressed air to blow solidified shortening out of the suction tube!
- The operator attempted to filter oil that was not heated. Cold oil is thicker and causes the pump motor to work harder and overheat.

If the motor hums but the pump does not rotate, there is a blockage in the pump. Incorrectly sized or installed paper will allow food particles and sediment to pass through the filter pan and into the pump. When sediment enters the pump, the gears can bind up and cause the motor to overload, tripping the thermal overload. Solidified shortening in the pump will also cause it to seize, with similar results.

A pump seized by debris or hard shortening can usually be freed by manually moving the gears with a screwdriver or other instrument as illustrated on the following page. **Make sure power to the pump motor is off before trying this.**

1. Disconnect power to the filter system.
2. Remove the input plumbing from the pump.
3. Use a screwdriver to manually turn the gears.
 - Turning the pump gears backwards will release a hard particle and allow its removal.
 - Turning the pump gears forward will push softer objects and solid shortening through the pump and allow free movement of the gears.

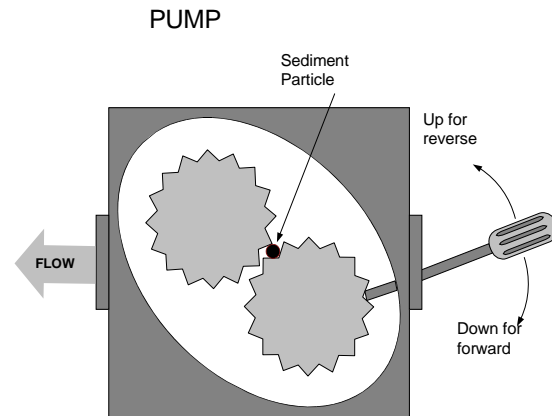

Filter pads that are installed incorrectly will also allow food particles and sediment to pass through and clog the suction tube recess on the bottom of the filter pan or the suction tube, itself. Particles large enough to block the suction tube recess or the suction tube may indicate that the crumb tray is not being used.

The electronics of the FootPrint PRO system, illustrated in the schematic below, are simple and straightforward.

Microswitches, which are attached to handles for each vat and wired in parallel, provide the 24 VAC required to activate the pump relay coil when the handles are moved to the ON position. The activated pump relay coil pulls in the pump motor switch, supplying power to the pump motor.

Verifying Solenoid Operation

Proper operation of the 24 VAC manifold and pump solenoids can be verified by removing the pump motor lead from terminal 4 of the pump motor relay in the filter wiring box and then activating the oil return lever. Proper solenoid operation will be evidenced by an audible “click” or vibration of both the pump solenoid and the manifold solenoid.

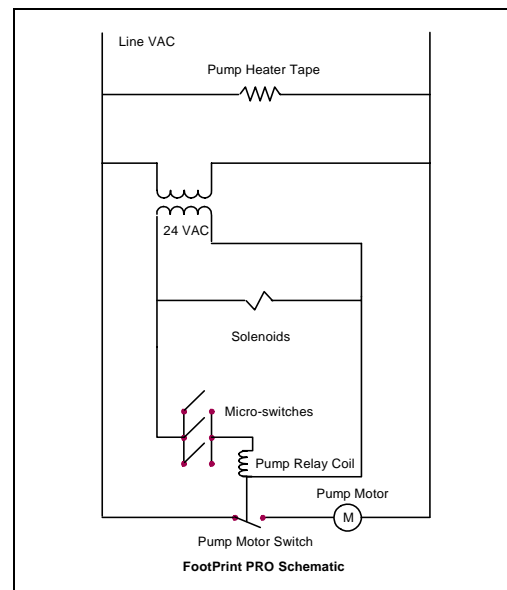

1.7.6 Leakage

Leakage of the frypot will usually be due to improperly sealed high-limit thermostats, temperature probes, and drain fittings. When installed or replaced, each of these components must be sealed with

Loctite® PST56765 sealant or equivalent to prevent leakage. In very rare cases, a leak may develop along one of the welded edges of the frypot. When this occurs, the frypot must be replaced.

If the sides or ends of the frypot are coated with oil, the most likely cause is spillage over the top of the frypot rather than leakage.

The clamps on the rubber boots that hold the drain tube sections together may loosen over time as the tubes expand and contract with heating and cooling during use. Also, the boot itself may be damaged. If the section of drain tube connected to the drain valve is removed for any reason, ensure that its rubber and clamps are in good condition and properly fitted around the drain tube when it is reinstalled. Also, check to ensure that the drain tube runs downward from the drain along its whole length and has no low points where oil may accumulate.

1.8 Troubleshooting Guides

The troubleshooting guides on the following pages are intended to assist service technicians in quickly isolating the probable causes of equipment malfunctions by following a logical, systematic process. An additional set of operator troubleshooting guides is contained in Chapter 6 of the BIPH52/55-MPH52/55 Series Installation and Operation Manual (P/N 819-6087). It is suggested that service technicians thoroughly familiarize themselves with both sets.

1.8.1 Troubleshooting the 24 VAC Circuit

Prior to checking for problems associated with the 24 VAC circuit, ensure that the unit is connected to a power supply, the drain valve is fully closed, and the controller is on and is calling for heat (green dot appears under heat indicator and display toggles between *L O W* and *T E M P*).

NOTE: All voltage measurements must be made within **4 seconds** of the unit calling for heat. If unit does not fire within **4 seconds**, ignition modules will lock out and controller must be turned off, then on to reset.

The following processes will assist you in troubleshooting the 24 VAC circuit and ruling it out as a probable cause:

- **24 VAC is not present on the interface board J3 pin 9 (LED 5 (GV)) and, on dual units, on J1 pin 9 (LED 1 (GV)).**
 1. If LED 3 *is not* continually lit, the probable causes are a failed 24 VAC transformer or failed wiring between transformer and interface board.
 2. If LED 3 *is* continually lit, check the right PWR terminal (LED 4) for 24 VAC. On dual units, also check the left PWR terminal (LED 2) for 24 VAC. Verify that the F2 fuse is not blown.
 - a. If 24 VAC *is not* present, the probable cause is a failed interface board, blown fuse or a defective heat relay.
 - b. If 24 VAC *is* present, check for 24 VAC on V1S (or V1D and V2D, if dual unit).

- i. If 24 VAC *is not* present, check the fuses. If they are good, the probable causes are failed ignition module(s) or a failed interface board. Replace the questionable ignition module with one known to be good to isolate the cause.
 - ii. If 24 VAC *is* present, the probable cause is a failed interface board.
- **24 VAC is present on interface board J3 pin 9 (LED 5 (GV)) and, on dual units, on J1 pin 9 (LED 1 (GV)).**
 1. If 24 VAC *is not* present across the gas valve main coil (MV terminals), probable causes are an open high-limit thermostat or a failed wire between the interface board and gas valve. Be sure to check both valves on dual units. It may also be caused by a failed drain safety switch.

Check continuity of high-limit thermostat and drain safety switch. If both are zero, problem is in wiring.
 2. If 24 VAC *is* present across the gas valve main coil (MV terminals), the 24 VAC circuit is okay and the problem may be with the gas valve. Be sure to check both valves on dual units.

24 VOLT CIRCUIT

With Interface Board 106-0386 and
One 807-3366 (FV) Ignition Module

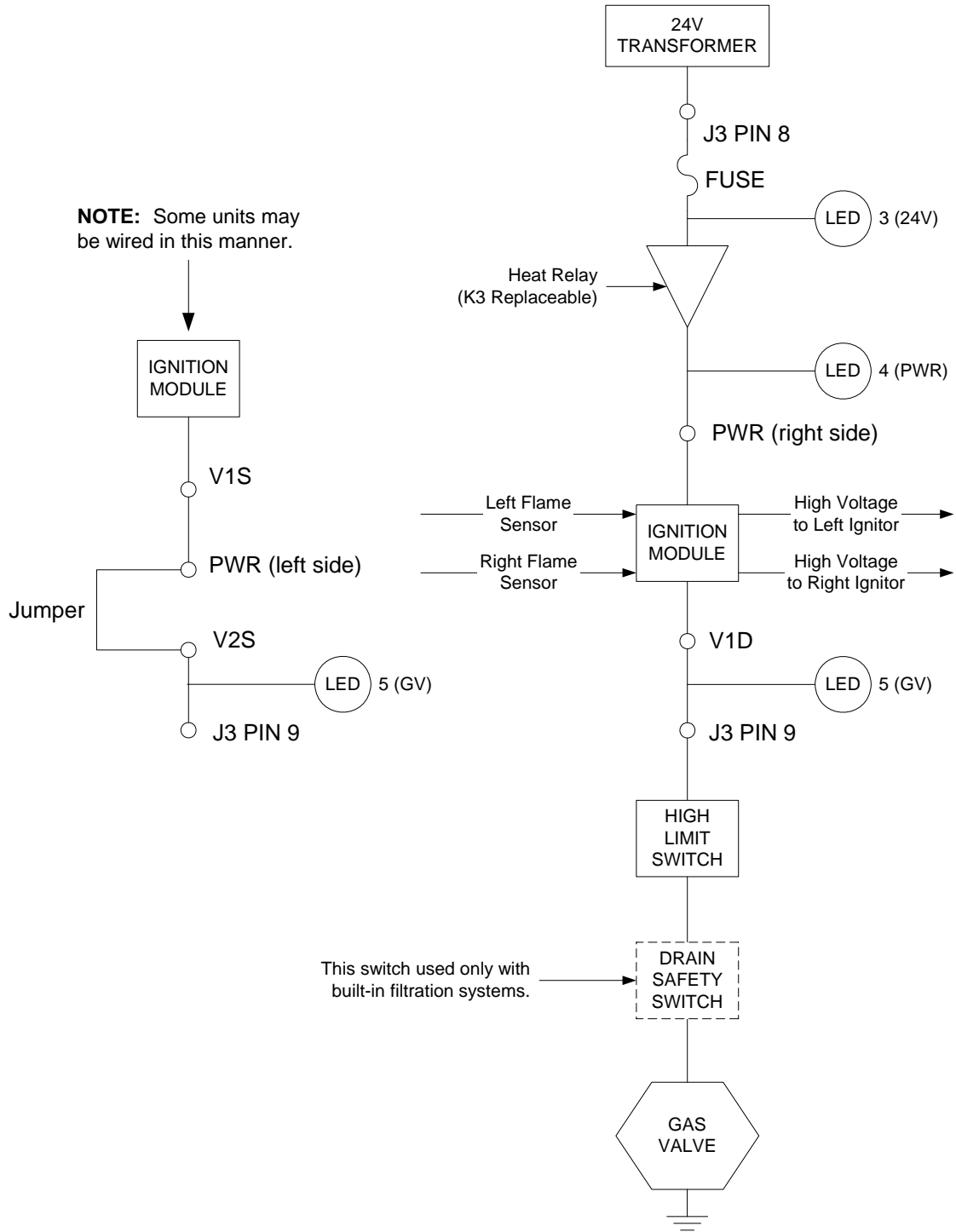

24 VOLT CIRCUIT

With Interface Board 106-0386 and
Two 807-3365 (DV) Ignition Modules

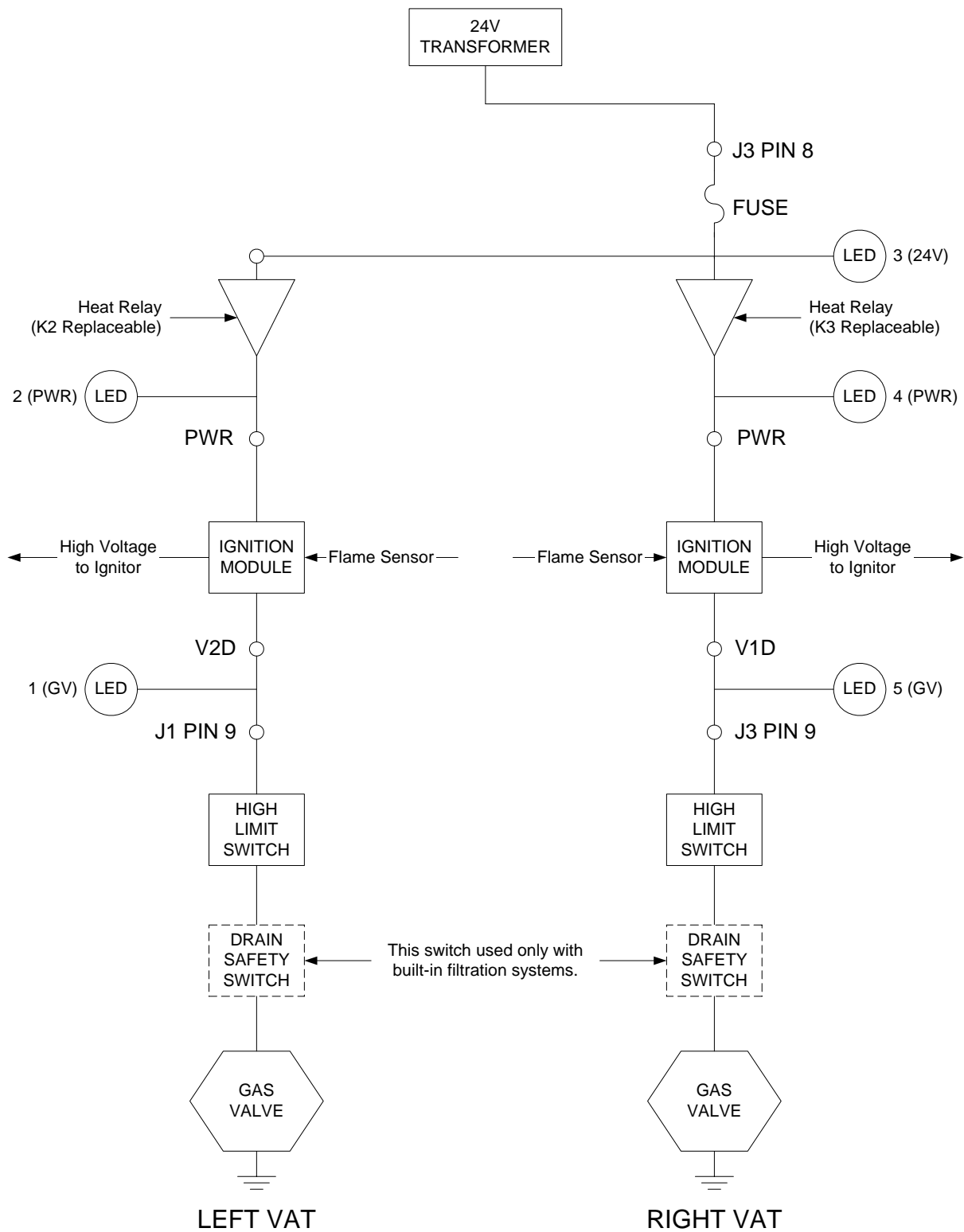

1.8.2 Troubleshooting the Gas Valve

Prior to checking for problems associated with the gas valve, ensure that the unit is calling for heat. Also, for non-CE units, verify that the gas valve is in the ON position.

The following processes will assist you in troubleshooting the gas valve and ruling it out as a probable cause:

- If 24 VAC is not present across gas valve main coil, the probable cause is the 24 VAC circuit. Refer to the 24 VAC circuit troubleshooting guide.
- If 24 VAC is present across gas valve main coil, check the incoming gas pressure and compare to the tables in Section 2.3 of the Installation and Operation manual.
 1. If incoming gas pressure *is not* correct, the probable cause is a problem with the gas supply to fryer.
 2. If incoming gas pressure *is* correct, check the outgoing gas pressure and compare it to the tables on Page 2-4 of the Installation and Operation manual.
 - a. If outgoing gas pressure *is not* correct, the probable cause is an improperly adjusted or failed gas valve. Adjust the valve by following the procedure “Check Burner Manifold Pressure” in Section 1.4 of this manual.

If the valve cannot be adjusted, replace it.

- b. If outgoing gas pressure *is* correct, the gas valve is okay.

1.8.3 Troubleshooting the Temperature Probe



Disconnect the M2000 computer before testing temperature probe resistances to avoid invalid readings

Prior to checking for problems associated with the temperature probe, inspect the probe body for damage while it is still in the frypot. Remove and replace the probe if it is bent, dented, or cracked. Also, inspect leads for fraying, burning, breaks, and/or kinks. If found, replace the probe.

The following processes will assist you in troubleshooting the gas valve and ruling it out as a probable cause:

Before testing the probe, determine the temperature the cooking oil using another thermometer or pyrometer placed at the tip of the questionable probe.

- If resistance through J3 pins 2 and 6 (J1 pins 2 and 6 for left side of dual unit) **is not** approximately equal to that given in the Probe Resistance Chart for the corresponding temperature, the probe has failed and must be replaced.

- If resistance through J3 pins 2 and 6 (J1 pins 2 and 6 for left side of dual unit) is approximately equal to that given in the Probe Resistance Chart for the corresponding temperature, measure the resistance through each of the previously tested pins to ground.
 1. If resistance *is not* 5 mega-Ohms or greater in each pin, the probe has failed and must be replaced.
 2. If resistance *is* 5 mega-Ohms or greater in each pin, the probe is okay.

1.9 Probe Resistance Chart

<h3 style="text-align: center;">Probe Resistance Chart</h3> <p style="text-align: center;"><i>For use with PRO Series fryers manufactured with Minco Thermistor probes only.</i></p>																	
F	OHMS	C	F	OHMS	C	F	OHMS	C	F	OHMS	C	F	OHMS	C	F	OHMS	C
60	1059	16	130	1204	54	200	1350	93	270	1493	132	340	1634	171			
65	1070	18	135	1216	57	205	1361	96	275	1503	135	345	1644	174			
70	1080	21	140	1226	60	210	1371	99	280	1514	138	350	1654	177			
75	1091	24	145	1237	63	215	1381	102	285	1524	141	355	1664	179			
80	1101	27	150	1247	66	220	1391	104	290	1534	143	360	1674	182			
85	1112	29	155	1258	68	225	1402	107	295	1544	146	365	1684	185			
90	1122	32	160	1268	71	230	1412	110	300	1554	149	370	1694	188			
95	1133	35	165	1278	74	235	1422	113	305	1564	152	375	1704	191			
100	1143	38	170	1289	77	240	1432	116	310	1574	154	380	1714	193			
105	1154	41	175	1299	79	245	1442	118	315	1584	157	385	1724	196			
110	1164	43	180	1309	82	250	1453	121	320	1594	160	390	1734	199			
115	1174	46	185	1320	85	255	1463	124	325	1604	163	395	1744	202			
120	1185	49	190	1330	88	260	1473	127	330	1614	166	400	1754	204			
125	1195	52	195	1340	91	265	1483	129	335	1624	168	405	1764	207			

1.10 Principal Wiring Connections

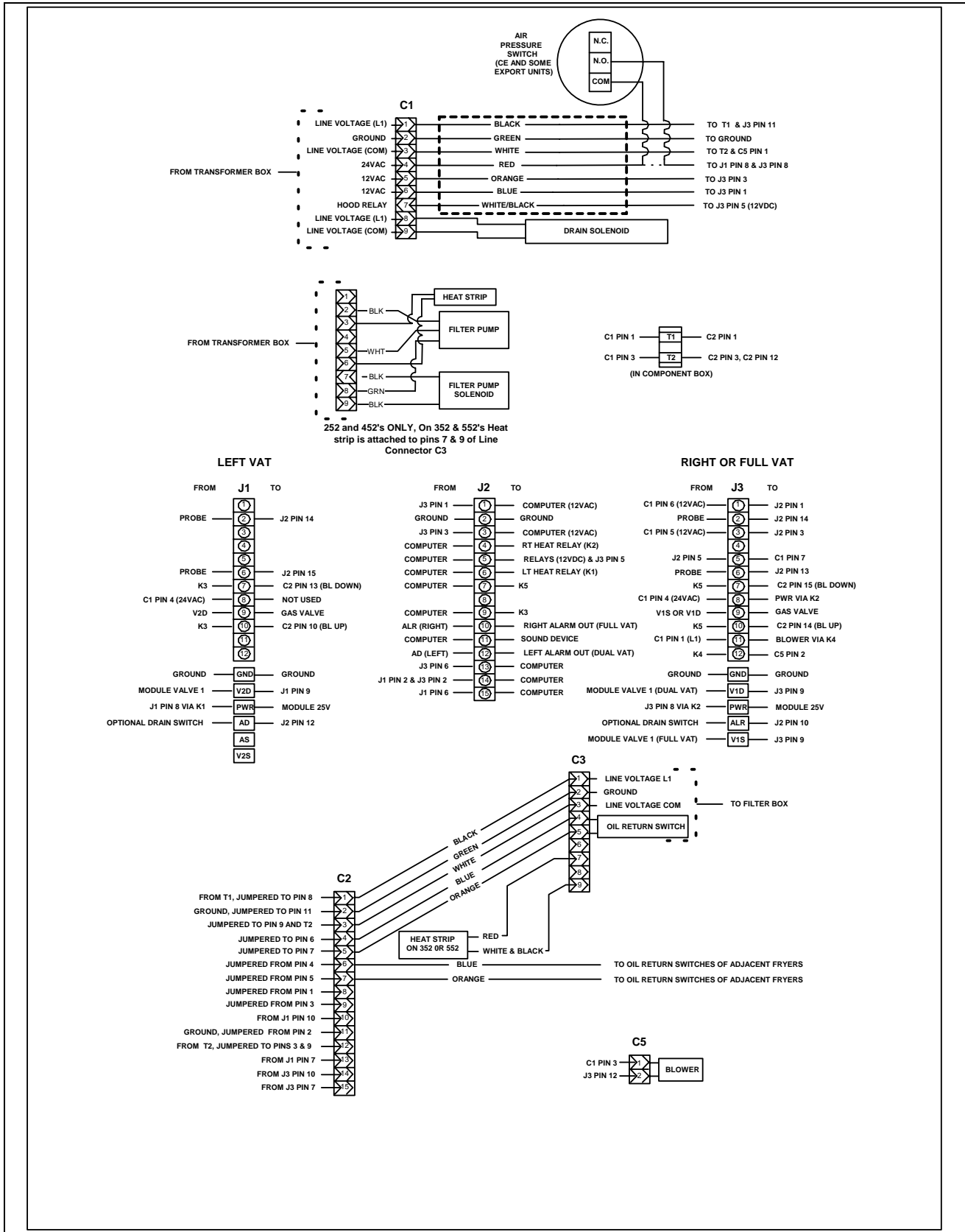

1.11 Wiring Diagrams

1.11.1 Main

The Heat Strip is not present here on 352/355's and 552/555's.

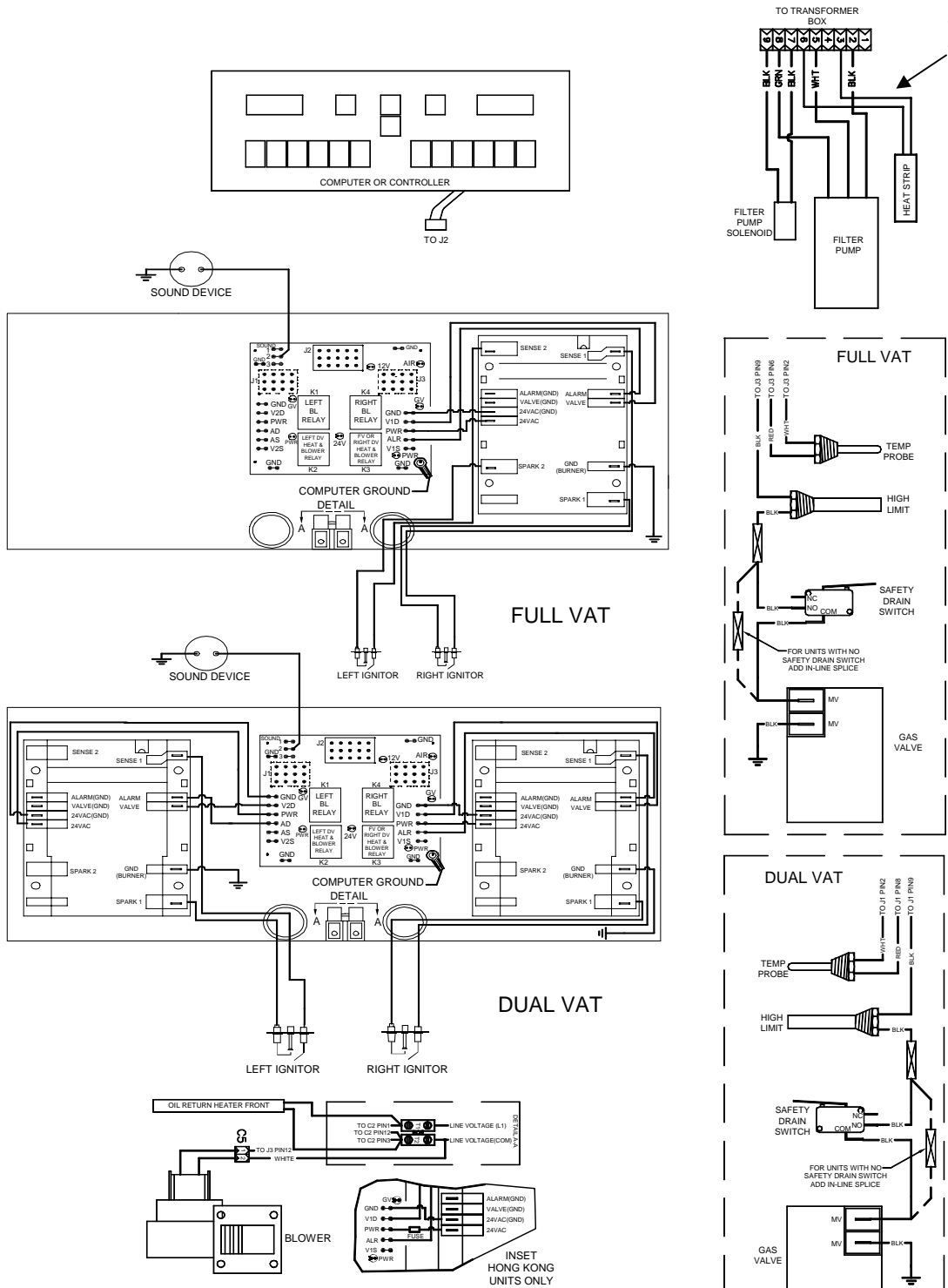

Refer to "PRINCIPAL WIRING CONNECTIONS" on Page 1-37 for detail of connection points J1, J2, J3, C2, C3, and C5.

8051315C/ 8051526B

1.11.2 Transformer / Filter Boxes

1.11.2.1 MPH152/155 Transformer / Filter Box

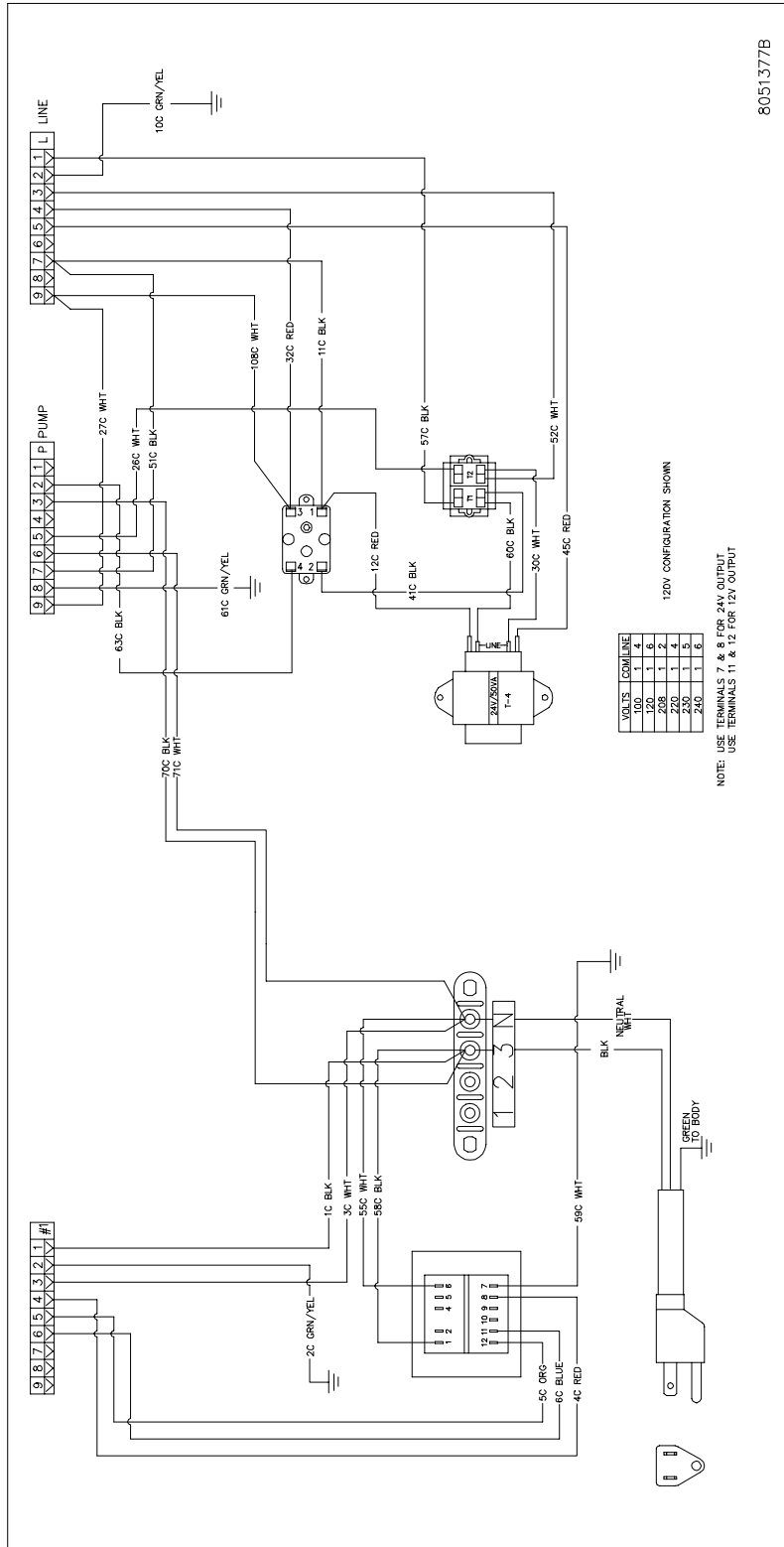

1.11.2.4 BIPH352/355 Transformer / Filter Box (Domestic)

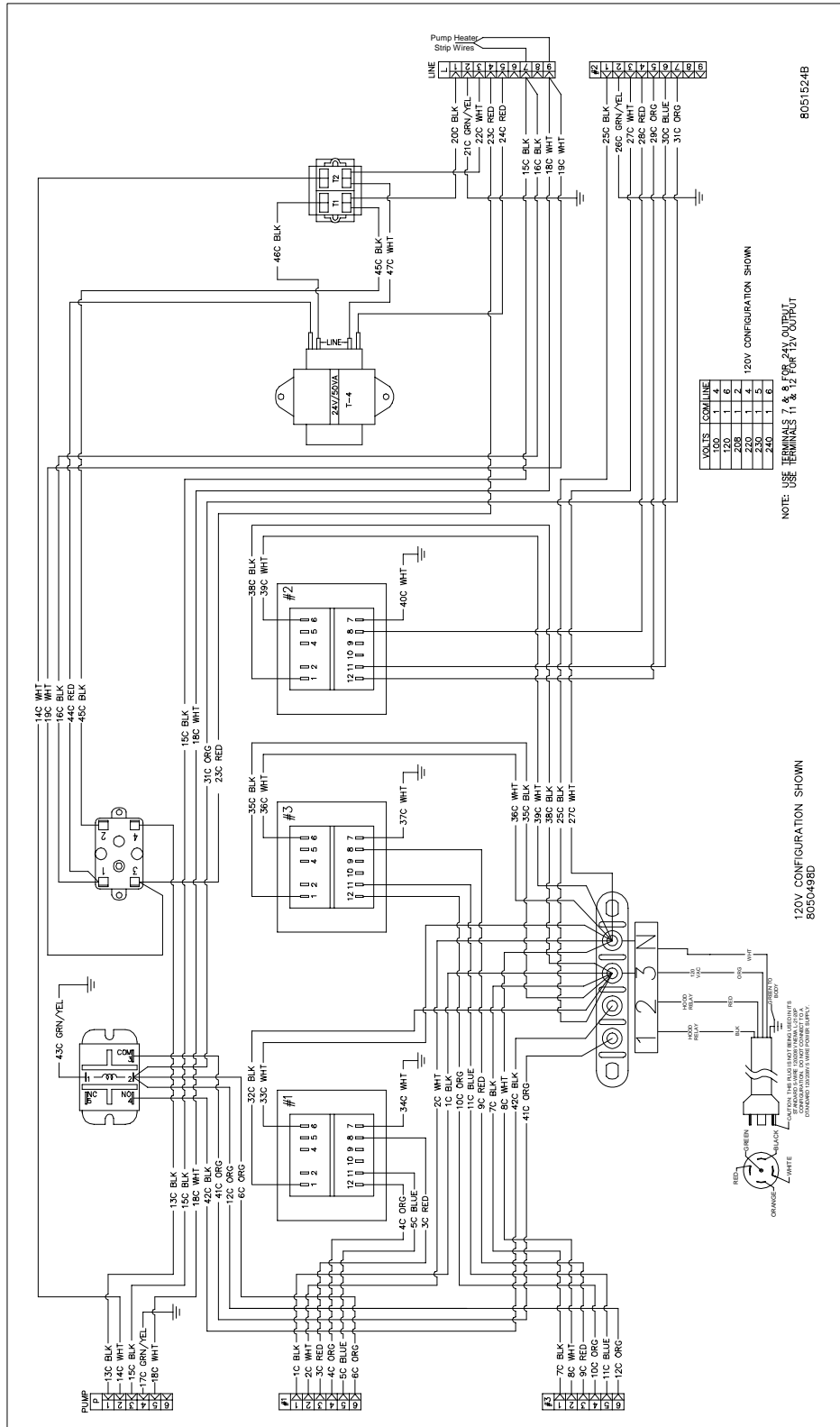

1.11.2.5 BIPH352/355 Transformer / Filter Box (International)

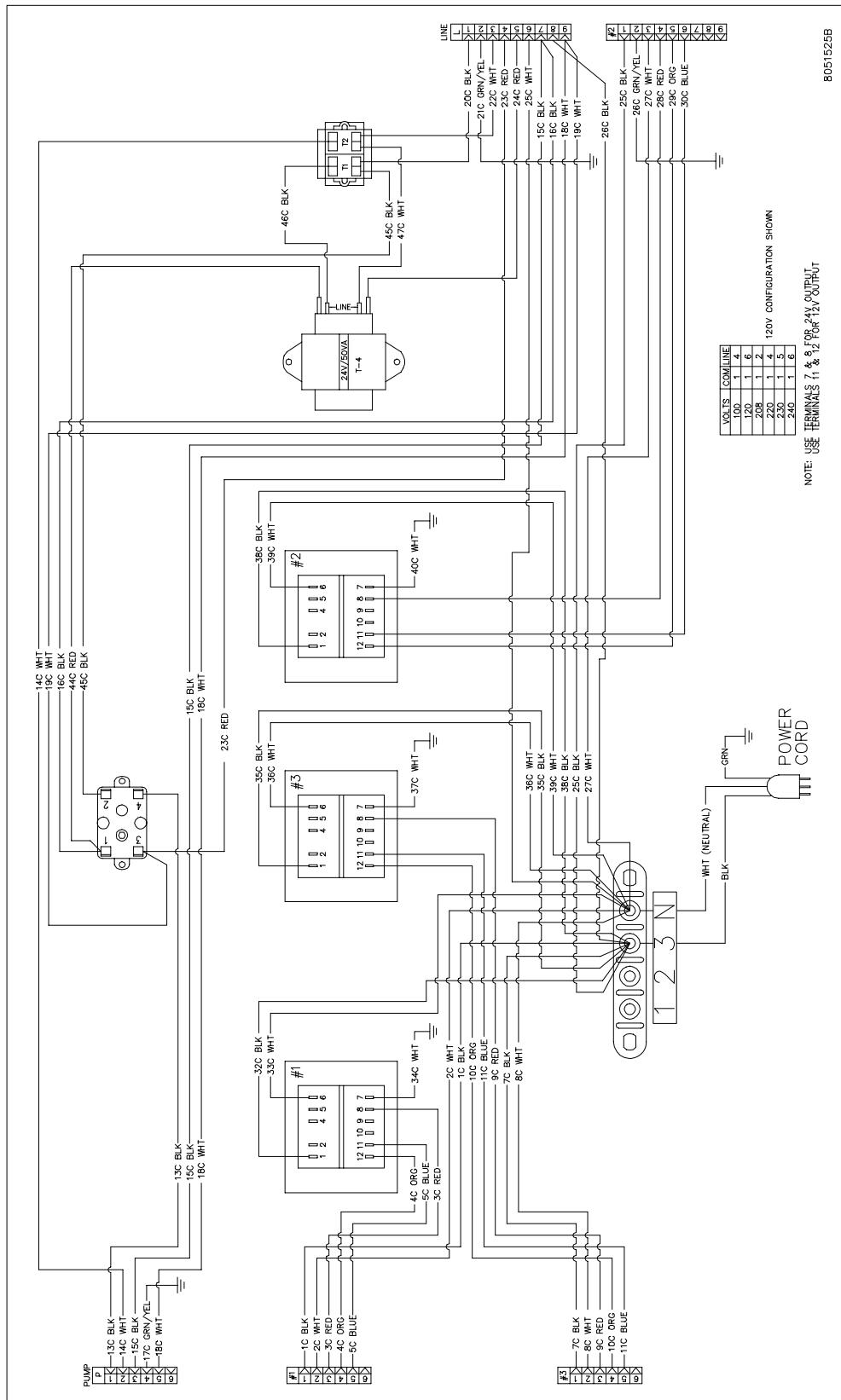

8051525B

1.12.2 BIPH52/55 Dual Vat

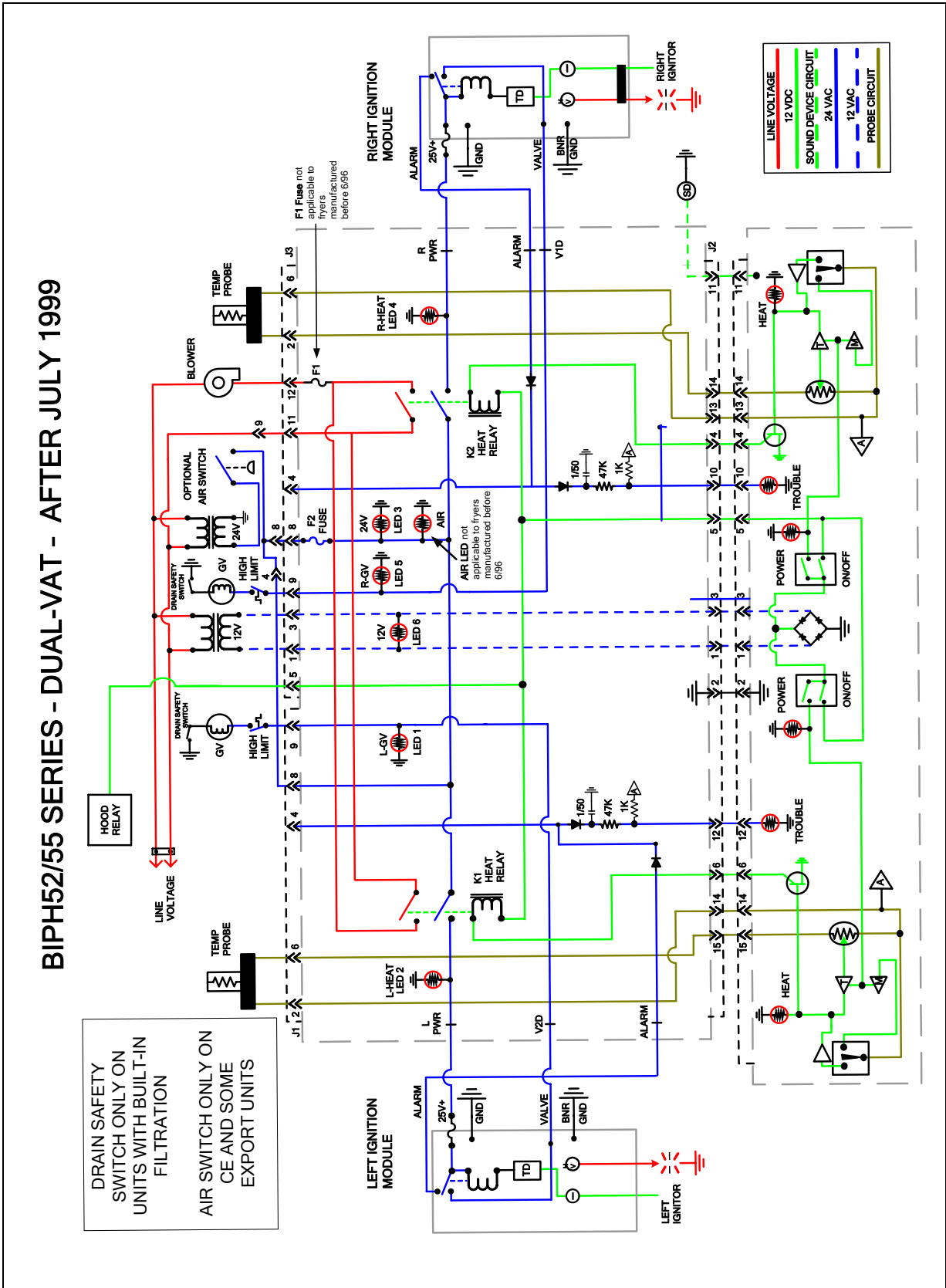

1.12.3 BIPH52/55 Series Full Vat (Australia and Pacific Rim)

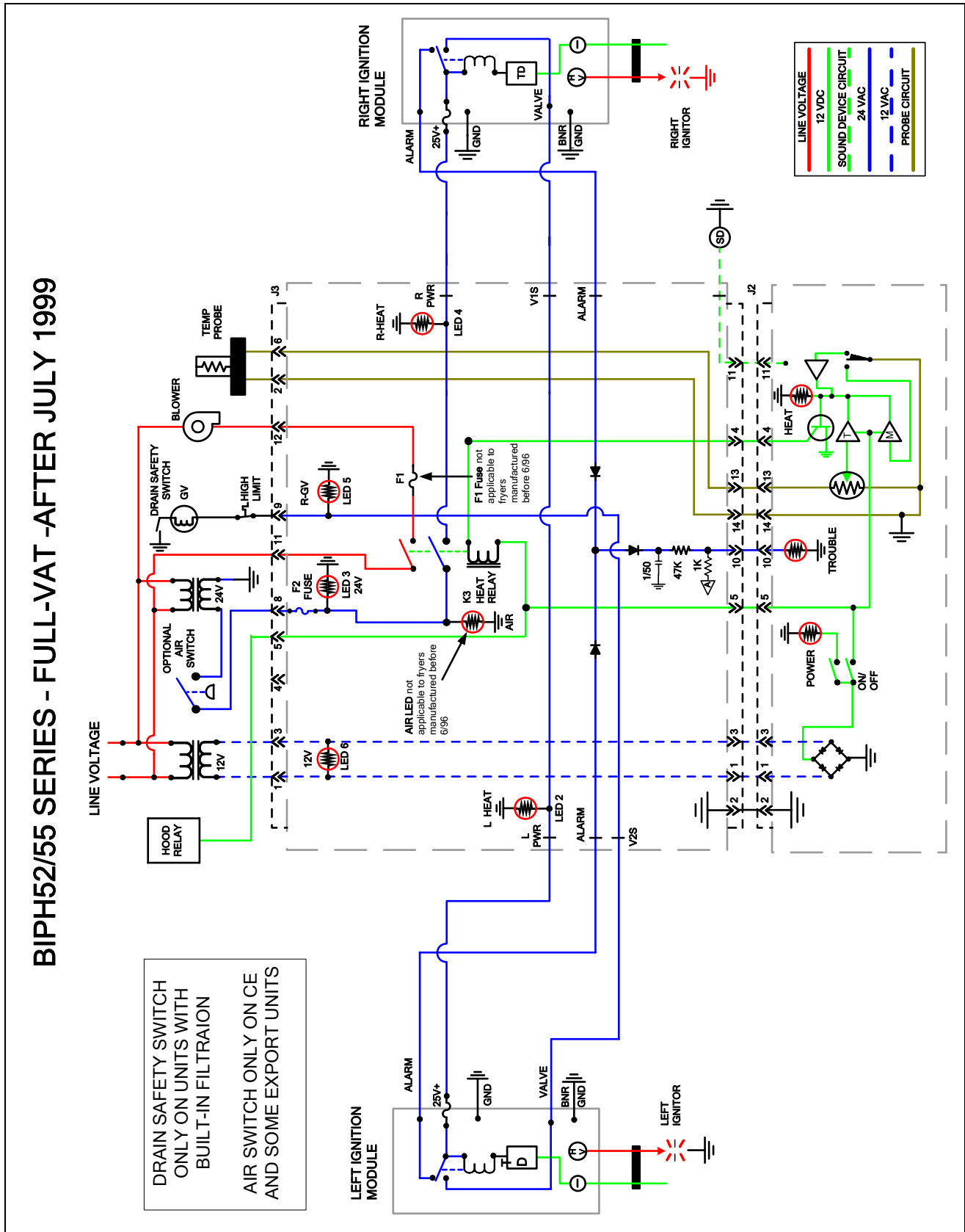

BIPH52/55-MPH52/55 GAS FRYERS

CHAPTER 2: PARTS LIST

2.1 Accessories

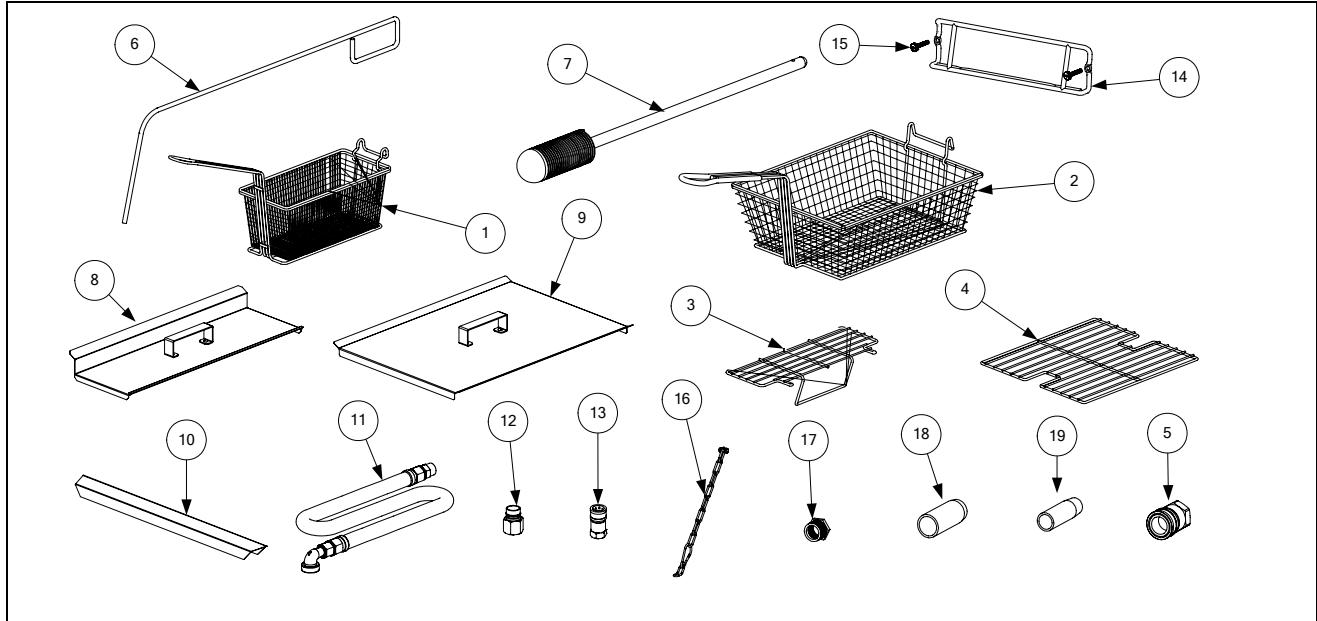

ITEM	PART #	COMPONENT
1	803-0271	Basket, Twin
2	803-0099	Basket, Full (cannot be used with basket lifts)
3	803-0133	Basket Support Rack, Dual Vat
4	803-0132	Basket Support Rack, Full Vat
*	803-0136	Basket Support Screen, Full Vat (screen w/handle used in place of Item 4)
5		Coupling, Gas Line Female Quick Disconnect
	810-0070	3/4-inch
	810-0073	1-inch
6	803-0197	Cleanout Rod, 27-inch (Fryer's Friend)
7	803-0209	Brush, Frypot
8	806-3407	Cover, Frypot, Dual Vat
9	806-3068	Cover, Frypot, Full Vat
*	826-0993SP	Handle Kit, Frypot Cover (includes handle and screws)
10	910-7443	Connecting Strip, Frypot
11	810-0478	Gas Line, 1-Inch Dormont Flexible
	806-1698SP	36-Inch (for gas line only (w/o Items 12 and 13), use 810-0088)
	806-1699	48-Inch (for gas line only (w/o Items 12 and 13), use 810-0085)
12	810-0074	Quick-Disconnect Fitting, 1-Inch Male
13	810-0073	Quick-Disconnect Fitting, 1-Inch Female
14	810-2793	Hanger, Basket
15	809-0171	Thumbscrew, 1/4-20 X 1 3/8-inch Basket Hanger
*	809-0921	Spacer, Basket Hanger
16	826-0900	Kit, Chain Restraint
17	826-1045	Bushing, Flexible Gas Line (813-0032)

ITEM	PART #	COMPONENT
18	812-1378	Drain Extension, Non-Filter Full Vat Fryer
19	812-1374	Drain Extension, Non-Filter Dual Vat Fryer
*	803-0219	Pad, McDonald's FPIII Universal Filter
*	803-0170	Filter Pack, Paper – 100 Sheets
*	803-0002	Powder, Filter – 80 Packages
*	826-1157	Kit, Fuse and Fuse Puller (2 Fuses)

* Not illustrated.

2.2 Cabinetry

2.2.1 Backs, Doors, Flue Caps, Sides, Top Caps, Standoffs and Cap-N-Splash Assemblies

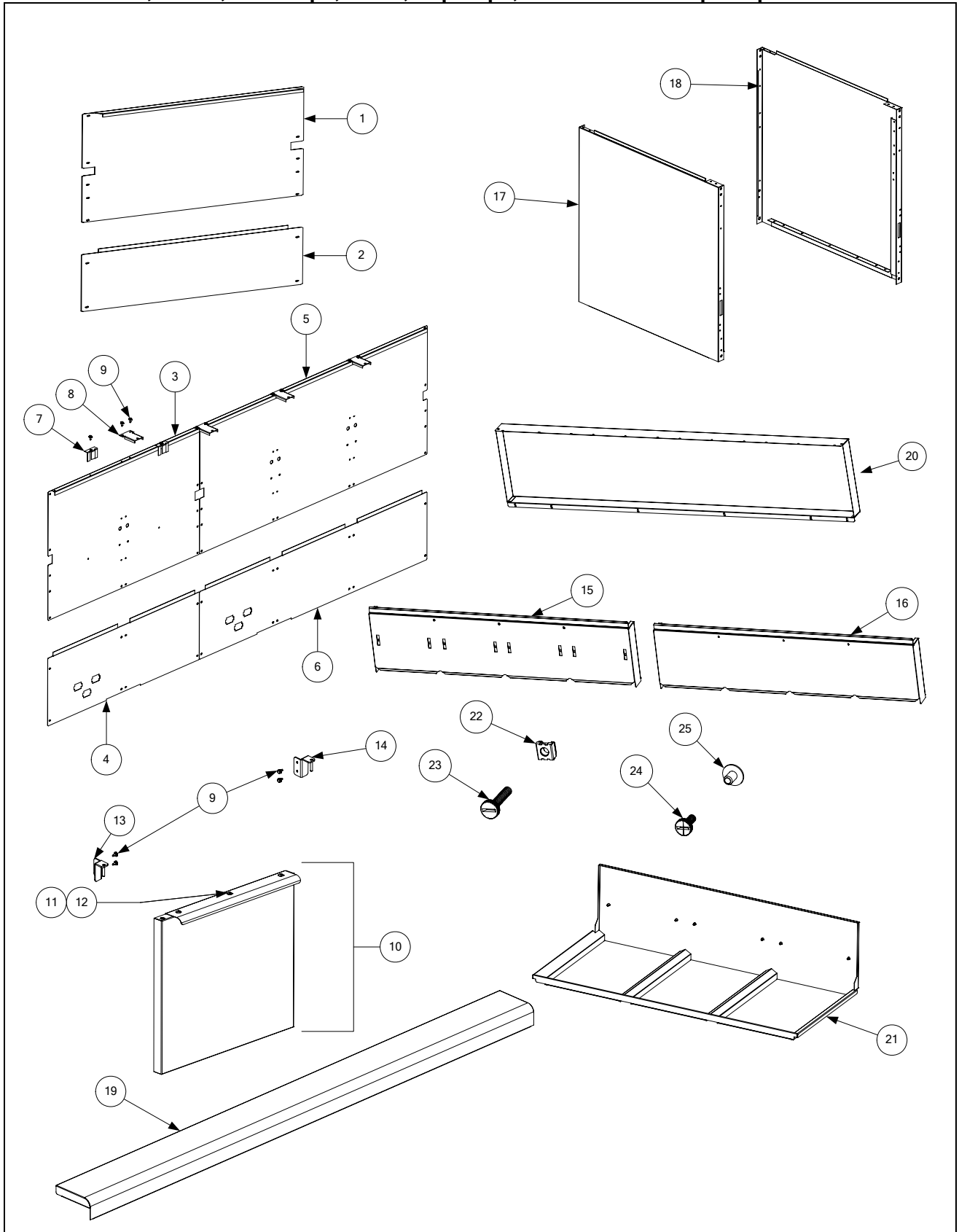

ITEM	PART #	COMPONENT
1		Back, Single Upper
	210-6581	Stainless Steel
	200-6581	Cold Rolled Steel
2		Back, Single Lower
	210-6580	Stainless Steel
	200-6580	Cold Rolled Steel
3		Back, Double Upper (for 2-, 4-, and 5-station fryers – does not include Items 7-9)
	210-6542	Stainless Steel
	200-6540	Cold Rolled Steel
4		Back, Double Lower (for 2-, 4-, and 5-station fryers – does not include Items 7-9)
	210-6541	Stainless Steel
	200-6539	Cold Rolled Steel
5		Back, Triple Upper (for 3- and 5-station fryers – does not include Items 7-9)
	210-6545	Stainless Steel
	200-6547	Cold Rolled Steel
6		Back, Triple Lower (for 3- and 5-station fryers – does not include Items 7-9)
	210-6544	Stainless Steel
	200-6546	Cold Rolled Steel
7	200-6419	Clip, Flue Support
8	200-5865	Support, Flue Cap
9	826-1374	Screw, #10 X ½-inch Hex Washer Head (Pkg. of 25)
10	106-3966	Door, Left or Right (Left shown – move handle to bottom for Right)
11	809-0266	Screw, #10 X ½-inch Phillips Truss Head
12	210-6816	Handle, Door
13	823-4729	Hinge, Left Door Upper
14	823-4730	Hinge, Right Door Upper
15		Flue Cap-Stainless Steel (Does not include Item 27)
	210-5549	Single Fryer
	106-3579	2-Station Fryer
	106-3537	3-Station Fryer
	106-3535	4-Station Fryer
	106-3536	5-Station Fryer
16		Flue Cap - Aluminized Steel for use with Cap-N-Splash
	210-5525	Single Fryer
	106-3539	2-Station Fryer
	106-3540	3-Station Fryer
	106-3542	4-Station Fryer
	106-3543	5-Station Fryer
17		Side, Left Standard Cabinet
	211-6510SP	Stainless Steel
	201-6633	Enameled Steel
18		Side, Right Standard Cabinet
	212-6510SP	Stainless Steel
	202-6633	Enameled Steel
19		Top Cap (Cap for 5-staion fryer shown)
	824-1310	Single Fryer (use 824-1689 for fryers mfd. After 3.15.06)
	824-1357	2-Station Fryer (use 824-1690 for fryers mfd. After 3.15.06)
	823-4702	3-Station Fryer (use 823-5733 for fryers mfd. After 3.15.06)
	823-4704	4-Station Fryer (use 824-5734 for fryers mfd. After 3.15.06)
	823-4706	5-Station Fryer (use 824-5735 for fryers mfd. After 3.15.06)

ITEM	PART #	COMPONENT
20		Standoffs
	200-6582	Single Fryer
	200-6553	2-Station Fryer
	200-6554	3-Station Fryer
	200-6555	4-Station Fryer
	200-6556	5-Station Fryer
21		Cap-N-Splash Assemblies
	823-3066	Single Fryer
	823-3067	2-Station Fryer
	823-3068	3-Station Fryer
	823-3070	4-Station Fryer
	823-3069	5-Station Fryer
22	826-1351	Nut Retainer, ¼-20 (Pkg. of 10 – for basket hanger thumbscrew) for Std. Fluecap
23	809-0171	Thumbscrew, ¼-20 x 1¾-inch (for use on Standard Fluecap)
24	809-0402	Thumbscrew, ¼-20 x ½-inch (for use on Cap-N-Splash Assembly)
25	809-0535	T-Nut, ¼-20 x 7/16-inch (for use on Cap-N-Splash Assembly)

2.2.2 Filter Cabinet Bases, Casters, Framing, and Related Components

The 5-station cabinet illustrated is typical of all BIPH52/55 Series Gas filter cabinets. All base and framing components used in BIPH52/55 Gas filter cabinets are identified, but not all components are used in every configuration.

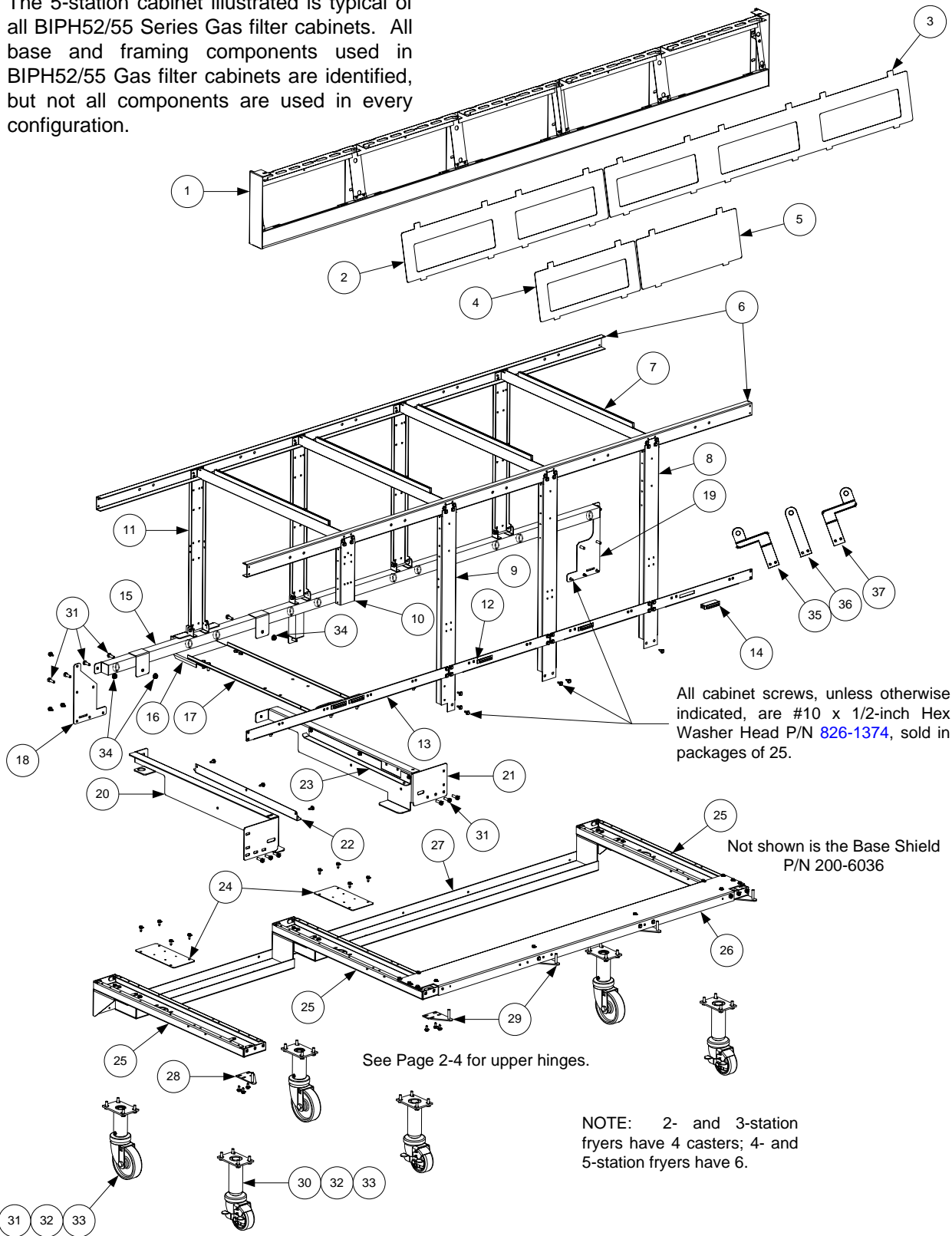

ITEM	PART #	COMPONENT
1	106-4303	Frame, Control Panel, Two Station, (<i>use 106-5221SP mfd. After 3.15.06</i>)
	106-4304	Three-Station, Standard (<i>use 106-5018SP mfd. After 3.15.06</i>)
	106-4305	Four-Station, Standard (<i>use 106-5019 mfd. After 3.15.06</i>)
	106-4306	Five-Station, Standard (<i>use 106-5020 mfd. After 3.15.06</i>)
2	210-5819	Bezel, Two-Controller
3	210-6698	Bezel, Three-Controller
4	210-5046	Bezel, One-Controller
5	210-5623	Bezel, Blank
6	900-7730	Brace, Cabinet Top Two-Station
	900-9430	Three-Station
	900-9318	Four-Station
	200-5474	Five-Station
7	200-5478	Divider, Cabinet
8	200-9217	Post, Cabinet Front
9	200-6031	Post, Filter Door
10	200-2235	Bracket, Component Box Support
11	200-6550	Post, Cabinet Rear
12	200-1953	Brace, Front Cabinet
13	200-6507	Support, Cross Cabinet
14	810-1105	Magnet, Door
15		Manifold, Rear (for units w/ filtration also see page 2-17 for additional parts)
	810-2890	Two-Station
	810-2891	Three-Station
	810-2892	Four-Station
	810-2893	Five-Station
16	200-2213	Bracket, Rear Bridge Support
17	200-9818	Bridge, Filter Pump
18	200-6326	Gusset, Left Rear Corner
19	200-7031	Gusset, Right Rear Corner
20	201-9467	Support, Left Filter Rail
21	202-9467	Support, Right Filter Rail
22	823-4651	Slide, Filter Pan Lid Left
23	823-4652	Slide, Filter Pan Lid Right
24	200-2102	Brace, Side Channel
25	823-4653	Channel, Side Base
26		Channel, Front Base (not used in two-station fryers)
	200-6609	Three-Station
	200-6610	Four-Station
	200-5473	Five-Station
27	823-4510	Channel, Rear Base Two-Station
	823-4630	Three-Station
	823-4629	Four-Station
	823-4628	Five-Station
28	823-4732	Hinge, Lower Left
29	823-4733	Hinge, Lower Right (<i>attach to Hinge Bracket 200-5478 in 4- & 5-station fryers</i>)
30	810-0944	Caster w/Brake, 8½ to 10-inch Adjustable (3-inch wheel)
31	810-0327	Caster w/o Brake, 8½ to 10-inch Adjustable (4-inch wheel)
32	809-0953	Bolt, ¼-20 x ¾-inch Hex Head
33	809-0191	Washer, ¼-inch Lock
34	809-0417	Nut, ¼-20 Flange
35	201-6720	Mount, Rear Flush Rod Offset, Left
36	200-6697	Mount, Rear Flush Rod Holder, Center
37	202-6720	Mount, Rear Flush Rod Offset, Right
*	200-6036	Base Shield

2.2.3 Non-Filter Cabinet Bases, Casters, Framing, and Related Components

The 5-station cabinet illustrated is typical of all MPH52/55 Series Gas non-filter cabinets. All base and framing components used in MPH52/55 Series Gas non-filter cabinets are identified, but not all components are used in every configuration.

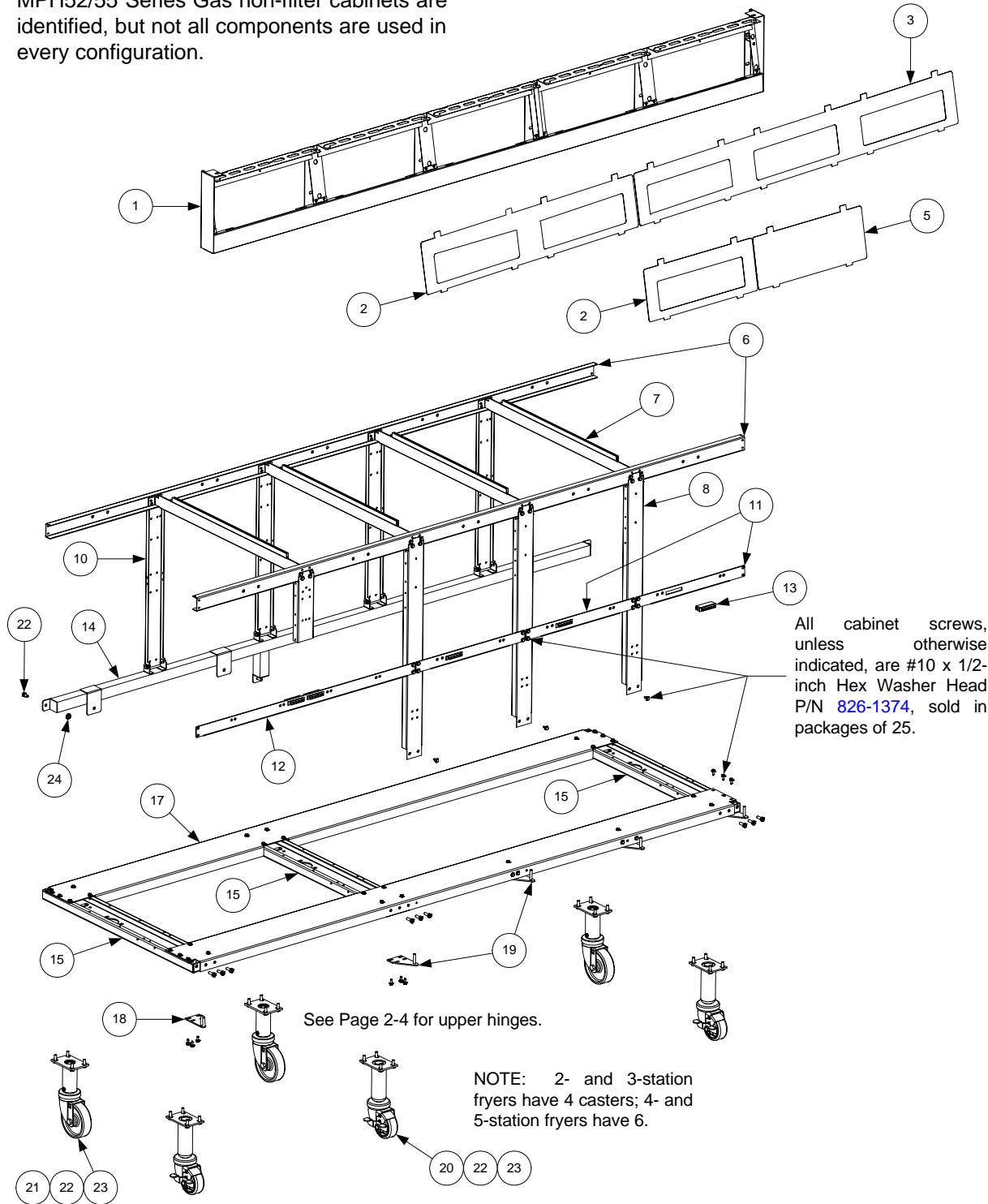

ITEM	PART #	COMPONENT
1		Frame, Control Panel
	106-4302	Single-Station, Standard (<i>use 106-5016 mfd. After 3.15.06</i>)
	106-4303	Two-Station, Standard (<i>use 106-5221SP mfd. After 3.15.06</i>)
	106-4304	Three-Station, Standard (<i>use 106-55018SP mfd. After 3.15.06</i>)
	106-4305	Four-Station, Standard (<i>use 106-5019 mfd. After 3.15.06</i>)
	106-4306	Five-Station, Standard (<i>use 106-5020 mfd. After 3.15.06</i>)
2	210-5819	Bezel, Two-Controller
3	210-6698	Bezel, Three-Controller
4	210-5046	Bezel, One-Controller
5	210-5623	Bezel, Blank
6		Brace, Cabinet Top
	200-5498	Single Fryer
	900-7730	Two-Station
	900-9430	Three-Station
	900-9318	Four-Station
	200-5474	Five-Station
7	200-5478	Divider, Cabinet
8	200-6614	Post, Cabinet Front
9	200-2235	Bracket, Component Box Support
10	200-6550	Post, Cabinet Rear
11	200-1953	Brace, Front Cabinet
12	200-6507	Support, Cross Cabinet
13	810-1105	Magnet, Door
14		Manifold, Rear (not present in single fryers)
	823-3223	Two-Station
	823-4691	Three-Station
	823-4693	Four-Station
	823-4694	Five-Station
15	823-4653	Channel, Side Base
16		Channel, Front Base
	200-6616	Single Fryer (<i>also used as rear base channel in single-station fryers</i>)
	200-6623	Two-Station (<i>also used as rear base channel in single-station fryers</i>)
	200-6624	Three-Station (<i>also used as rear base channel in single-station fryers</i>)
	200-6625	Four-Station
	200-6627	Five-Station
17		Channel, Rear Base
	200-6626	Four-Station
	200-6628	Five-Station
18	823-4732	Hinge, Lower Left
19	823-4733	Hinge, Lower Right (<i>attach to Bracket 200-5478 in 3-, 4-, & 5-station fryers</i>)
20	810-0944	Caster w/Brake, 8½ to 10-inch Adjustable (3-inch wheel)
21	810-0327	Caster w/o Brake, 8½ to 10-inch Adjustable (4-inch wheel)
22	809-0953	Bolt, ¼-20 x ¾-inch Hex Head
23	809-0191	Washer, ¼-inch Lock
24	809-0417	Nut, ¼-20 Flange

2.3 Controllers and Associated Components

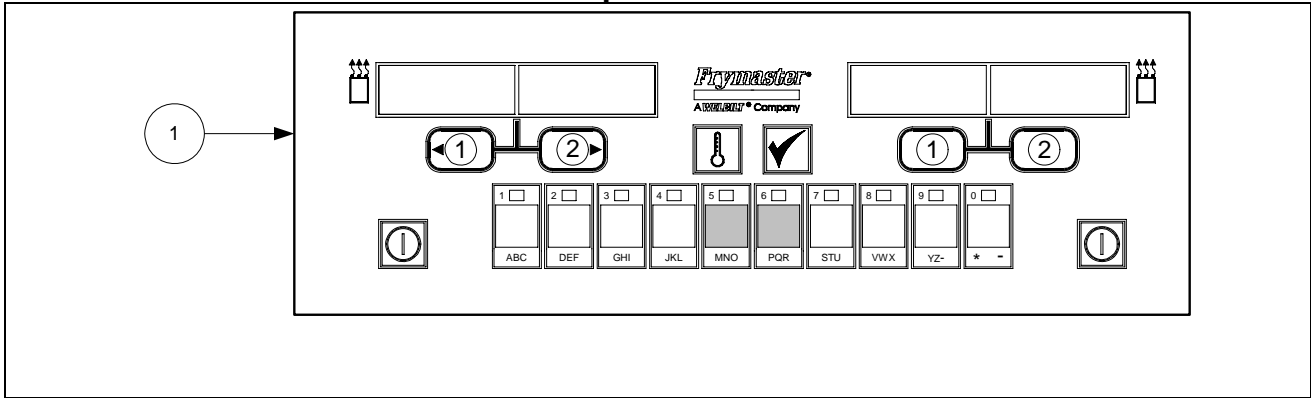

ITEM	PART #	COMPONENT
1		Computer, McDonald's M2000 Gas Fryer
	106-1269	Full Vat (Domestic U.S.) Can also be programmed for Dual Vat.
	106-0672	Full Vat (CE) Can also be programmed for Dual Vat.
	106-5950	Full Vat (CE) Can also be programmed for Dual Vat (<i>Australia Only</i>)
*	807-3520	M2000 Speaker

* Not illustrated.

2.4 Drain, Filtration, and Oil Return System Components

2.4.1 Filtration System Components

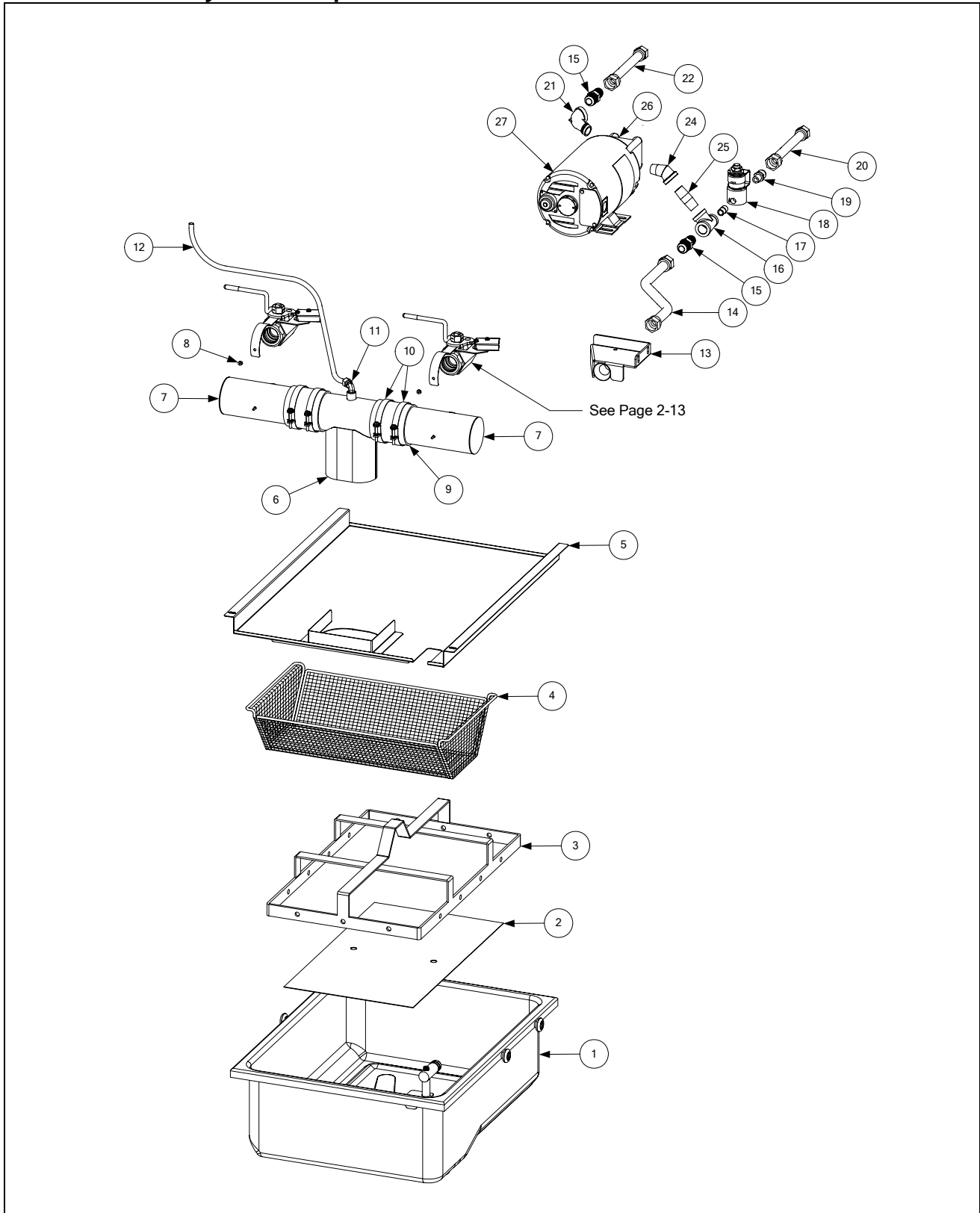

ITEM	PART #	COMPONENT
1	106-2617SP 826-1980 823-3930SP 813-0568 826-1392 810-2198 826-1372 826-1979	Pan Assembly, FootPrint Pro Filter (incl. O-rings, rollers, nuts & crumb tray) Pan Assembly – No Screen Pan Assembly, Filter Plug, 1/8-inch NPT Socket Head O-Ring (two required) (Pkg. of 5) Roller, Filter Pan Nut, 1/4-20 Hex Flange (Pkg. of 10) Kit- Contains four each of roller 810-2198 and 1/4-20 Flange Nut 809-0059
2	200-2240	Screen, Sana Grid
3	810-2183 810-2091	Ring, Filter Pad Hold-Down Ring (11.20-inch X 19.10-inch) Ring, Filter Paper Hold-Down Ring (13.47-inch X 21.41-inch)
4	823-5146	Tray, Filter Pan Crumb
5	823-5249	Lid, Filter Pan
6	823-4678 823-4708	Tube, 3-inch Center Drain (Open Both Ends) Closed One End
7		Tube, 3-inch Round Drain (823-4625 illustrated)
	823-4638	Dual Vat, Long (one end closed)
	823-4640	Dual Vat, Long (open both ends)
	823-4624	Dual Vat, Short (one end closed)
	823-4642	Dual Vat, Short (open both ends)
	823-4639	Full Vat, Long (one end closed)
	823-4641	Full Vat, Long (open both ends)
	823-4625	Full Vat, Short (one end closed)
	823-4643	Full Vat, Short (open both ends)
	200-6473	Spreader, Long (open both ends, no drain valve connection)
	200-6474	Spreader, Short (open both ends, no drain valve connection)
8	809-0247	Nut, 8-32 Hex Keys
9	816-0625	Sleeve, Round Drain Connector
10	809-0969	Clamp, Round Drain Sleeve
11	810-2493	Elbow, 1/4-inch NPT X 90° Tube Compression
12	811-1071	Tube, 1/4-inch OD Teflon Manifold Vent
13	823-3879	Suction Tube, FootPrint Pro Female
14	810-1055	Flexline, 5/8-inch OD X 11.50-inch
15	810-1668	Adapter, 5/8-inch OD X 1/2-inch Male
16	813-0530	Tee, 1/2-inch X 1/2-inch X 1/4-inch Reducing
17	813-0838	Nipple, 1/4-inch NPT Close
18	807-2484	Solenoid Valve w/Female Pins
19	810-2773	Adapter, 1/2-inch OD Flare x 1/4-inch NPT
20	810-2787	Flexline, 1/2-inch OD X 5.00-inch
21	813-0165	Elbow, 1/2-inch NPT X 90° Street
22	810-1680	Flexline, 5/8-inch OD x 11.50-inch
23	813-0265	Nipple, 1/2-inch NPT X 2.50-inch
24	813-0342	Elbow, 1/2-inch NPT X 45° Street
25	813-0298	Nipple, 1/2-inch NPT X 2.00-inch
26	826-1264	Pump and Gasket Kit (for gasket only, order P/N 816-0093)
27		Motor and Gasket Kit, 50/60 Hz (for gasket only, order P/N 816-0093)
	826-1785	100V
	826-1712	115V
	826-1756	208V
	826-1270	220-240V
	826-1755	250V

2.4.2 Drain Valves and Associated Components

Non-Filter Drain Valve Assemblies

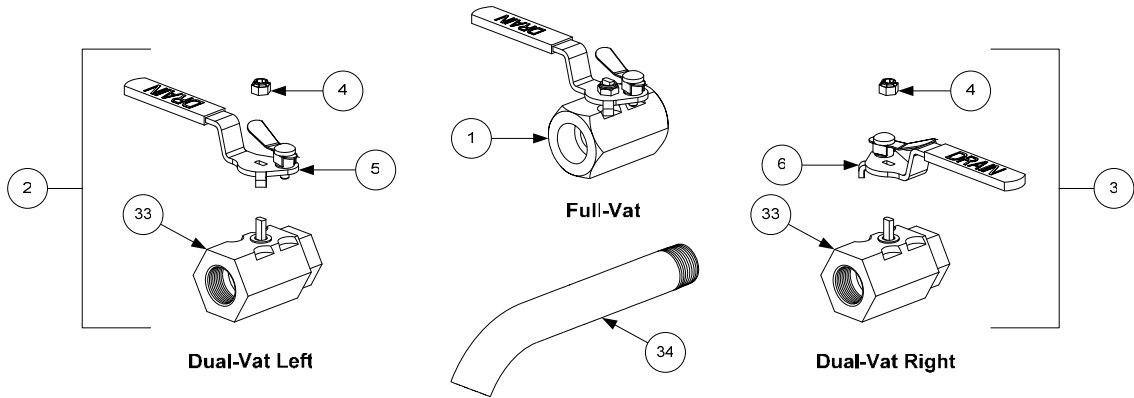

FootPrint Pro Drain Valve Assemblies

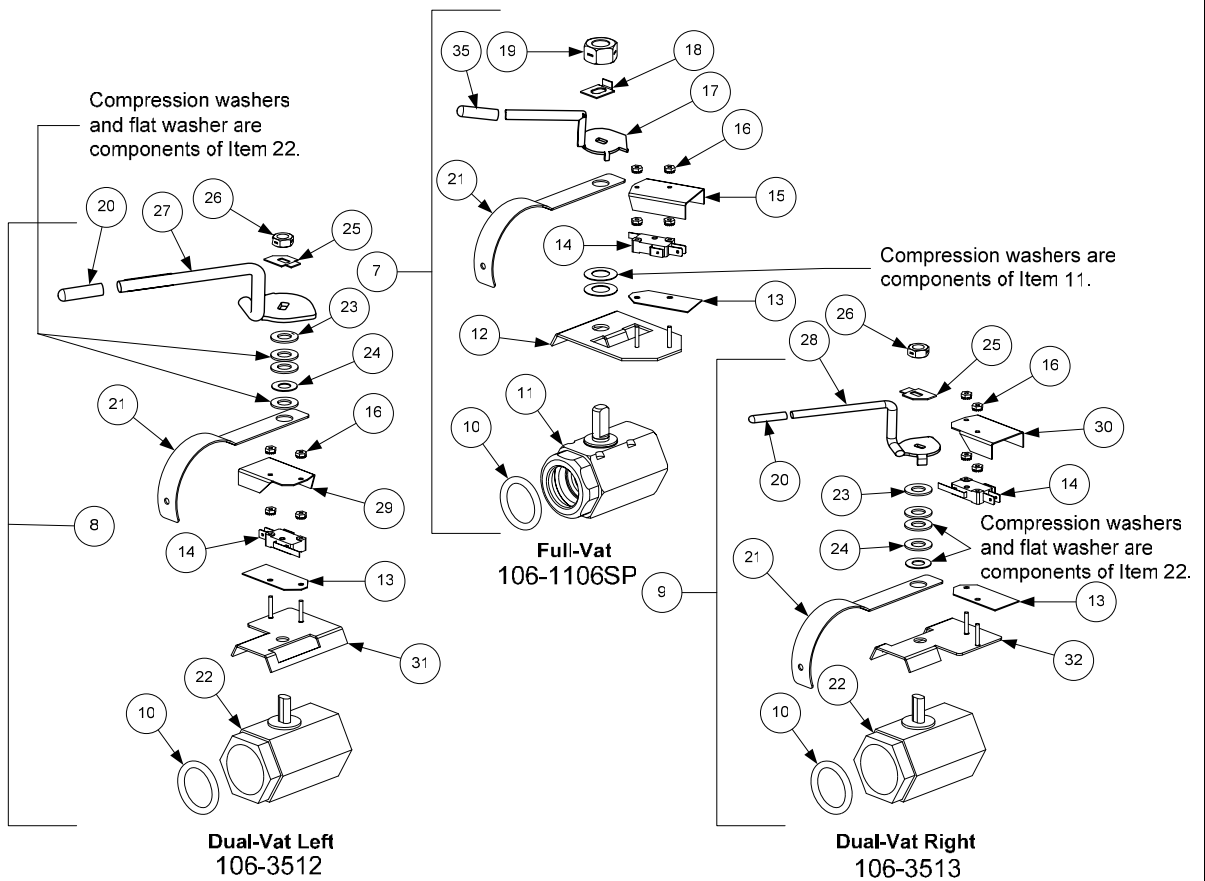

ITEM	PART #	COMPONENT
1	810-1569	Valve Assembly, 1.25-inch Full-Vat Non-Filter Drain (includes handle)
*	810-1427	Lock Pin Handle for 1.25-inch Valve Assembly
2	806-7915SP	Valve Assembly, 1-inch Left Dual-Vat Non-Filter Drain (complete assembly)
3	806-7916SP	Valve Assembly, 1-inch Right Dual-Vat Non-Filter Drain (complete assembly)
4	809-0589	Nut, ½-13 2-Way Lock (used on non-filter drain valves)
5	810-1568	Handle w/Lock Pin, Left Drain Valve
6	810-1567	Handle w/Lock Pin, Right Drain Valve
7	106-1106SP	Valve Assembly, 1.25-inch Full-Vat w/Filter Drain (complete assembly)
8	106-3512	Valve Assembly, 1-inch Left Dual-Vat w/Filter Drain (complete assembly)
9	106-3513	Valve Assembly, 1-inch Right Dual-Vat w/Filter Drain (complete assembly)
10	816-0135	O-Ring, Drain Valve
11	810-1018	Valve, 1.25-inch Drain
12	806-8137	Bracket Assembly, Drain Safety Switch
13	816-0220	Insulation, Drain Safety Switch
14	807-2103	Microswitch, Lever Activated
15	900-2841	Cover, Full-Vat Drain Safety Switch
16	826-1366	Nut, 4-40 Hex Keps (Pkg. of 25)
17	824-1602	Handle, Full-Vat Drain Valve
18	900-2936	Retainer, Full-Vat Drain Valve Nut
19	809-0540	Nut, ½-13 2-Way Lock
20	816-0677	Grip, Drain Valve Handle
21	200-6496	Support, 3-inch Drain Tube
22	810-1114	Valve, 1-inch Dual-Vat w/Filter Drain
23	809-0196	Washer, ⅜-inch Flat
24	810-1165	Washer, ⅜-inch Teflon
25	900-2934	Retainer, Dual-Vat Drain Valve Nut
26	809-0539	Nut, ⅜-16 2-Way Lock
27	823-4578	Handle, Left Dual-Vat Drain Valve
28	823-4577	Handle, Right Dual-Vat Drain Valve
29	901-2348	Cover, Left Dual-Vat Drain Safety Switch
30	902-2348	Cover, Right Dual-Vat Drain Safety Switch
31	106-2671	Bracket Assembly, Left Dual-Vat Drain Safety Switch
32	106-2672	Bracket Assembly, Right Dual-Vat Drain Safety Switch
33	810-1338	Valve, 1-Inch Dual-Vat Non-Filter Drain
34		Drain Valve Extension
	812-1226SP	Full-Vat (1.25-inch)
	812-1227	Dual-Vat (1-inch)
35	816-0639	Grip, Drain Valve Handle 5/16" x 3"

2.4.3 Rear Flush Oil Return Line Components

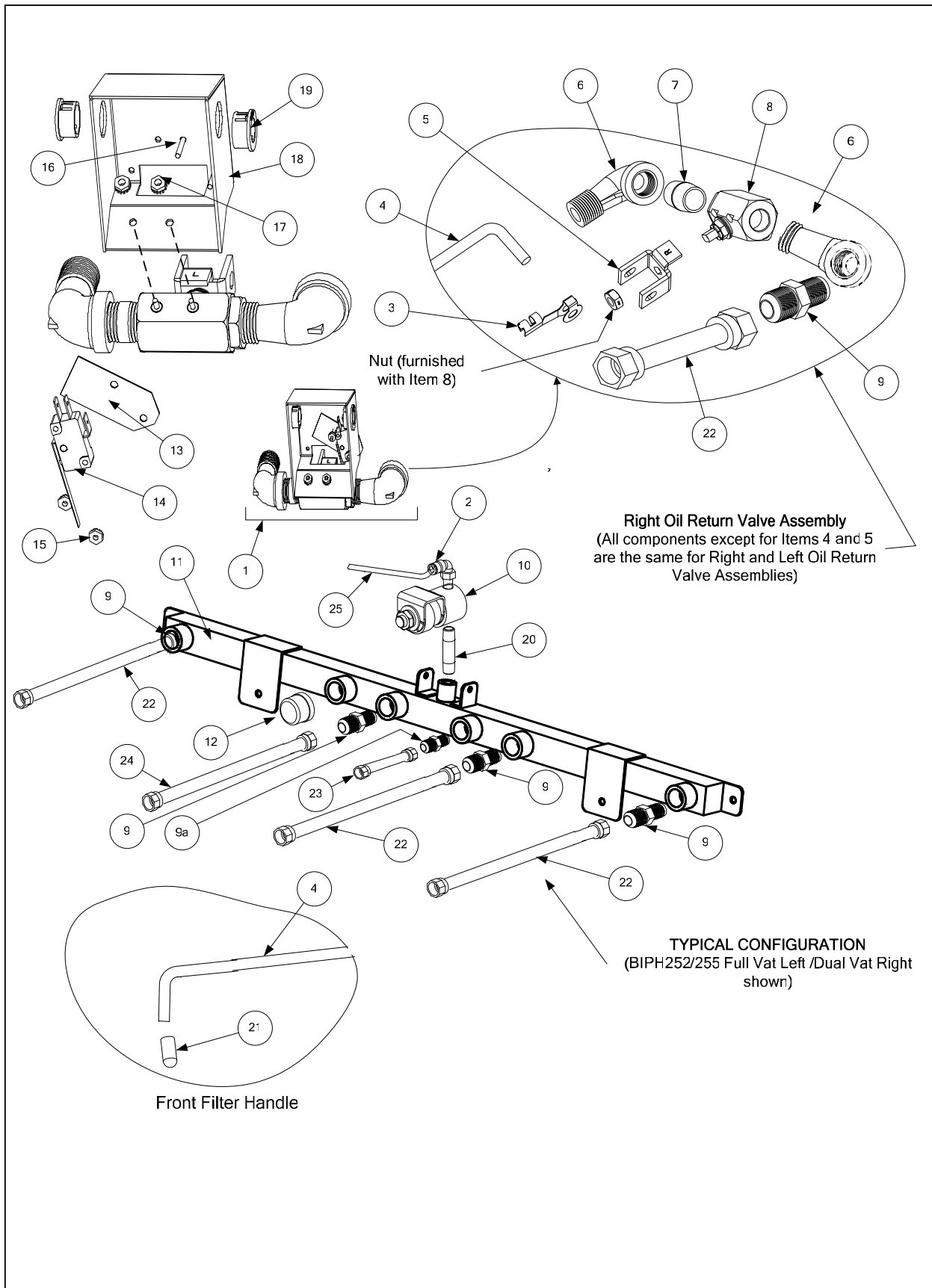

ITEM	PART #	COMPONENT
1		Valve Assembly, Microswitch and Ball Valve
	106-3452	Valve Rear Flush Assembly, Left Side
	106-3453	Valve Rear Flush Assembly, Right Side
2	810-2493	Elbow, 90° x ¼-inch
3	809-0601	Clip, Rod End Clevis
4		Shaft, Rear Flush Valve
	211-6701	For use in Left oil return valve assemblies.
	212-6701	For use in Right oil return valve assemblies.
5		Handle, Rear Flush Valve
	901-2772	For use in Left oil return valve assemblies.
	902-2772	For use in Right oil return valve assemblies.
6	813-0165	Elbow, 90° x ½-inch Street
7	813-0087	Nipple, 1½-inch BM NPT
8	810-2201	Valve, ½-inch Ball
*	900-2935	Oil Return Valve Nut Retainer
9	810-1668	Adapter, Male ⅝-inch Flexline to ½-inch NPT Male
9a	810-2786	Adaptor, ½-inch Flare x ½ -inch NPT
10	807-2484	Valve, ¼-inch NPT Solenoid Vent
11		Manifold, BIPH52 Rear Flush Oil Return
	810-2890	Two-Station Fryer
	810-2891	Three-Station Fryer
	810-2892	Four-Station Fryer
	810-2893	Five-Station Fryer
12	813-0156	Cap, ½-inch Pipe
13	816-0220	Insulation, Rear Flush Switch
14	807-4101	Microswitch, Lever Activated
15	826-1366	Nut, 4-40 Keps Hex (Pkg. of 25)
16	826-1359	Screw, 4-40 x ¾-inch Slotted Round Head (Pkg. of 25)
17	809-0250	Nut, 6-32 Keps Hex
18	200-8745	Cover, Microswitch Rear Flush
19	807-0125	Bushing, .50 ID Heyco SB-750-8 Nylon
20	813-0700	Nipple, ¼ NPT x 3-inch
21	816-0643	Grip, Oil Return Handle
22	810-1067	Flexline, ⅝-inch OD x 8.50-inch Oil Return
23	810-2787	Flexline, ½" x 5.00-inch Pump to Oil Return Manifold
24	810-1680	Flexline, ⅝-inch OD x 6.50-inch Oil Return Manifold to Pump
25	811-1071	Tube, ¼-inch OD Teflon Manifold Vent

2.5 Electronics and Electrical Components (for Controllers, Page 2-10)

2.5.1 Component Boxes

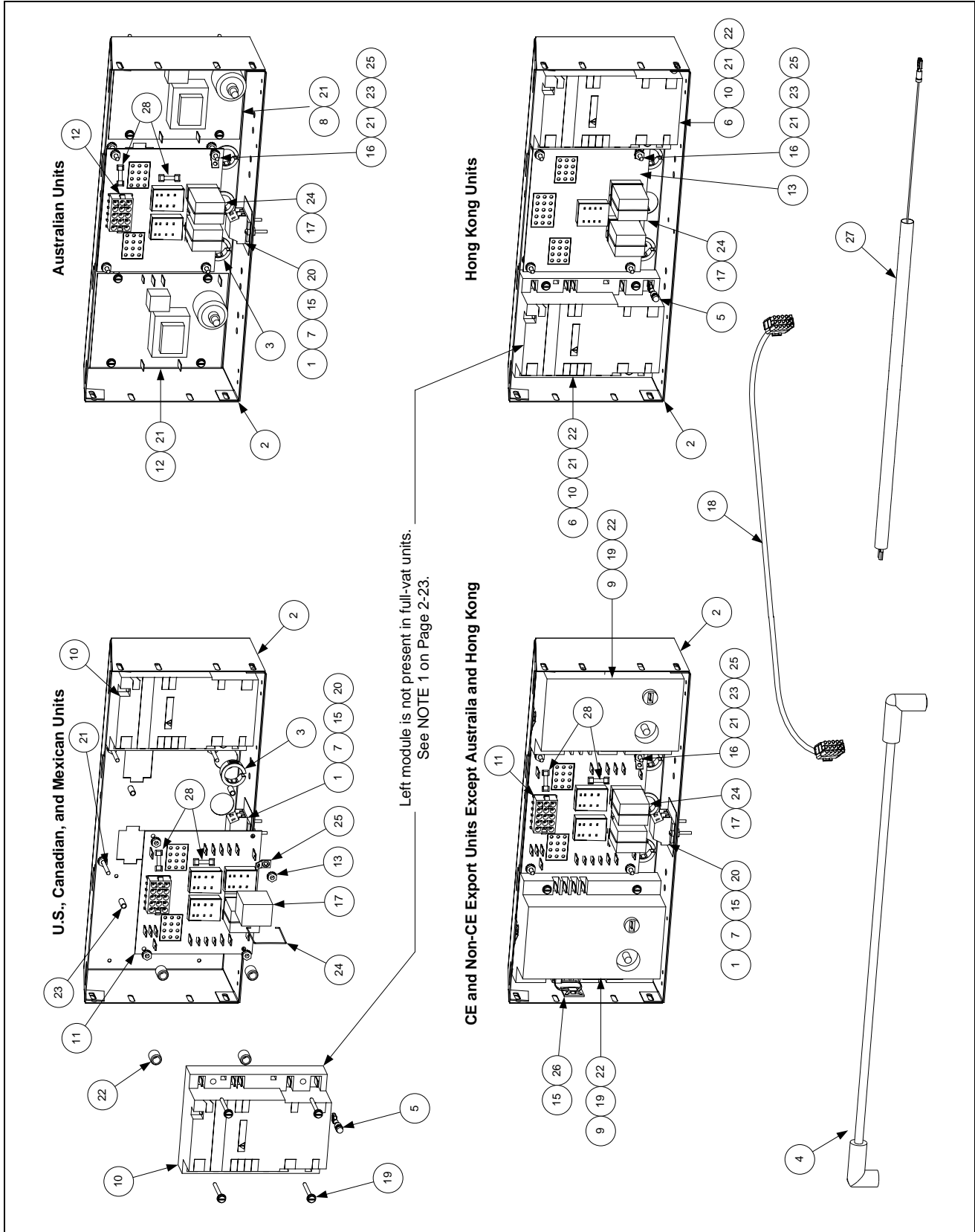

ITEM	PART #	COMPONENT
1	810-1164	Block, One-Piece Screwless Terminal
2	200-5996	Box, One-Piece Component
3	807-1926	Bushing, .875-inch Split
4	807-3483	Cable, 21-inch Ignition H50/H52 –For 807-3366/3365 Modules
*	826-2024	Cable, Ignition - 1 wire / 1 rajah
*	826-1721	Cable, Ignition – 2 wire / 2 rajah
5	807-3484	Connector, Rajah
6	106-0531SP	Fuse Assembly, Inline
7	816-0217	Insulation, Terminal Block Paper
8	807-2971	Ignition Module, Australian
9	807-1006	Ignition Module, CE and Non-CE export (<i>except Australia, Canada, HK, Mexico</i>)
10	807-3366†	Ignition Module, Dual-Spark Full-Vat (<i>U.S., Canadian, HK, and Mexican units</i>)
	807-3365†	Ignition Module, Single-Spark Ignition Module Dual-vat (<i>U.S., Canadian, HK, and Mexican units</i>)
11	826-2264	Interface Board Kit; U.S., CE and non-CE (<i>except Hong Kong</i>)
	106-6706	Interface Board SMT, U.S., CE and non-CE (<i>except Hong Kong</i>)
	807-4330	Sound Device/Speaker Adapter Harness SMT
	807-4343	Wire Harness, SMT Interface Board to Ignition Module
12	106-0387	Interface Board, Australian
13	806-4973	Interface Board, Hong Kong
14	807-1359	Mount, Ty-Wrap
15	826-1366	Nut, 4-40 Keps Hex (Pkg. of 25)
16	809-0250	Nut, 6-32 Keps Hex
17	807-0833	Relay, DPDT 5A 12VDC Latch (See NOTE 1.)
18	806-2071	Cable, 15-pin Computer to Interface Board
19	809-0441	Screw, #8 X 1½-inch Hex Washer Head
20	826-1359	Screw, 4-40 X ¾-inch Slotted Round Head (Pkg. of 25)
21	809-0098	Screw, 6-32 X 1¼-inch Slotted Round Head
22	826-1346	Spacer, Ignition Module (Pkg. of 10)
23	810-2763	Spacer, Interface Board
24	810-2243	Spring, Relay Retaining
25	826-1337	Tab, ¼-inch Terminal (Pkg. of 5)
26	807-1948	Ty-Wrap
27	806-6085SP	Wire Assembly, Ignition Module
28	807-3843	Fuse 3A 250V Domestic
	807-3293	Fuse 5A 125V International Only
*	807-1200	Ignition Wire, 27”
*	807-1878	Ignition Wire, 19”
*	807-3520	Sound Device, High Output

* Not illustrated.

† For Dual-vat units, use 807-3365 Single Spark Ignition Module (see **NOTE 1**).

NOTE 1: U.S., Canadian, Hong Kong, and Mexican units use two different modules depending upon the configuration of the frypot. Dual-Vat units use two 807-3365 Single-Spark Ignition Modules. Full-Vat units use one 807-3366 Dual-Spark Ignition Module. Also, in full-vat units, only one latch relay (Item 17) is used, located in the lower right socket.

2.5.2 Transformer Boxes

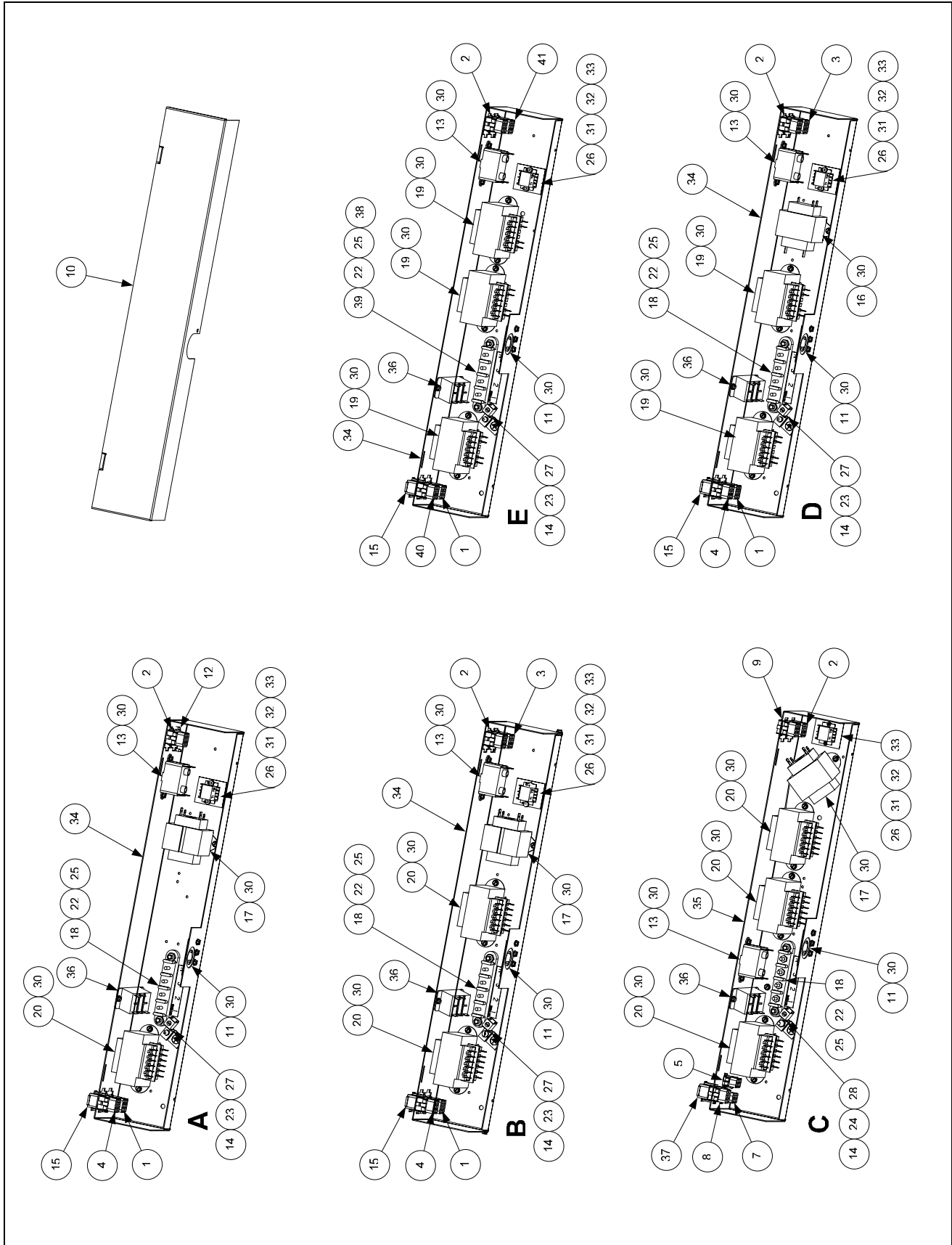

2.5.2 Transformer Boxes Continued

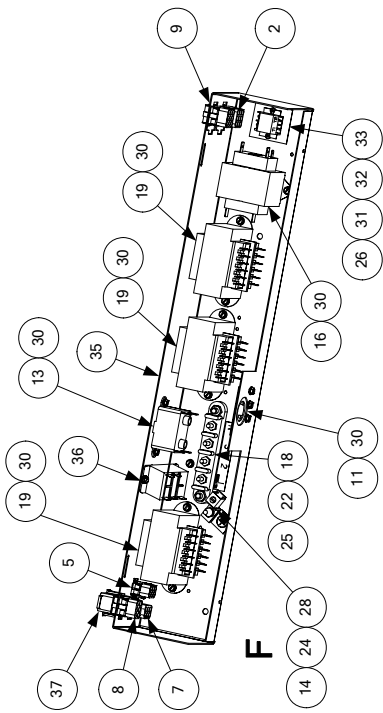
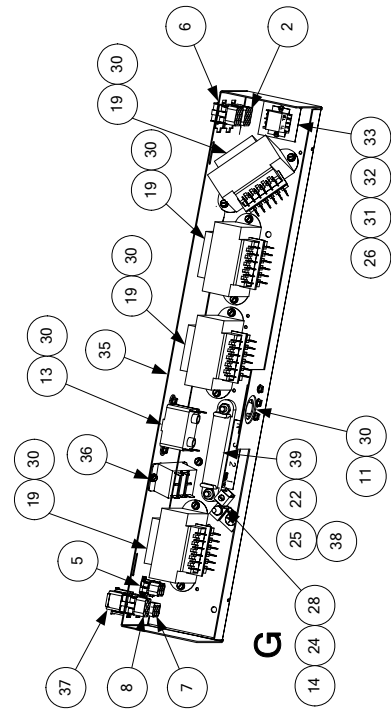

ITEM	PART #	COMPONENT
		Box Assembly, Transformer
A	106-1380	100-120V FMPH152/155, FMPH352/355, FMPH452/455
B	106-3818	100-120V BIPH 252/255, BIPH 452/455, FMPH252/255
C	106-4888	100-120V BIPH 352/355
D	106-3819	208-240V BIPH 252/255 and BIPH 452/455 CE/Non-CE Export
E	106-3817	250V BIPH 252 and BIPH 452 CE/Non-CE Export
F	106-3824	208-240V BIPH 352/355 CE/Non-CE Export
G	106-3823	250V BIPH 352/355 CE/Non-CE Export
1	106-3820	Cable Assembly, Transformer Box #1
2	106-3821	Cable Assembly, Transformer Box #2
3	106-1011	Cable Assembly, Transformer Box Line
4	106-1016	Cable Assembly, Transformer Box Filter Pump
5	106-3827	Cable Assembly, Transformer Box #1 (On Box G this PN# becomes 106-4898)
6	106-4990	Cable Assembly, Transformer Box Line
7	106-3825	Cable Assembly, Transformer Box #3
8	106-3826	Cable Assembly, Transformer Box Filter Pump
9	106-3316	Cable Assembly, Transformer Box Line
10	200-1415	Cover, Transformer Box
11	200-6721	Plate, Strain Relief
12	200-2318	Cover, Transformer Box Cable Plate
13	807-0012	Relay, 18 Amp 1/3-HP 24V Coil
14	807-0070	Terminal, Ground Lug
15	807-0155	Connector, 9-Pin Male
16	807-0680	Transformer, 208-240V/24VAC 50/60Hz 20VA
17	807-0800	Transformer, 100-120V/24VAC 50/60Hz 50VA (On Box C PN# is 807-1238)
18	807-1973	Terminal, Post
19	807-1999	Transformer, 208-240V V/F Dual Voltage
20	807-2176	Transformer, 100-120V V/F Dual Voltage
21	809-0052	Nut, 10-24 Hex
22	826-1362	Nut, 1/4-20 Hex (Pkg. of 10)
23	826-1363	Screw, 8-32 X 1/2-inch Slotted Truss Head (Pkg. of 25)
24	809-0123	Screw, 10-24 X 3/4-inch Slotted Truss Head
25	826-1389	Screw, 1/4-20 X 3/4-inch Hex Head (Pkg. of 10)
26	826-1366	Nut, 4-40 Keps Hex (Pkg. of 25)
27	809-0247	Nut, 8-32 Keps Hex
28	826-1376	Nut, 10-32 Keps Hex (Pkg. of 10)
29	826-1359	Screw, 4-40 X 3/4-inch Slotted Round Head (Pkg. of 25)
30	809-0360	Screw, #8 X 3/8-inch Hex Washer Head
31	809-0656	Screw, 4-40 X 3/8-inch Slotted Round Head
32	810-1164	Block, One-Piece Screwless Terminal
33	816-0217	Insulation, Terminal Block Paper
34	824-1242	Box, Transformer BIPH252, 452
35	824-1301	Box, Transformer BIPH352, 552
36	807-1683	Relay, Hood 12V DC
37	807-0157	Connector, 6-Pin Male
38	816-0219	Paper, CE Triple Terminal Block Insulating
39	810-1163	Block, 3 Places Screwless Terminal
40	106-4894	Cable Assembly, Transformer Box Filter Pump
41	106-4893	Cable Assembly, Transformer Box Line

Continued on Next Page

Continued from Previous Page		
ITEM	PART #	COMPONENT
*	WIR 0623	Wire Assembly, PH52 Hood Relay
*	WIR0634	Wire Assembly, FPP50 Transformer/Filter Box (used in Item E)
*	WIR0635	Wire Assembly, FPPH350 Transformer Filter Box (used in Item G)
*	WIR0439	Wire Assembly, Transformer Box (used in Items B, D, and E)
*	WIR0447	Wire Assembly, Transformer Box (used in Item A)
*	WIR0580	Wire Assembly, Transformer Box (used in Item C)

* Not illustrated

2.5.3 High-Limit Thermostat and Temperature Probe

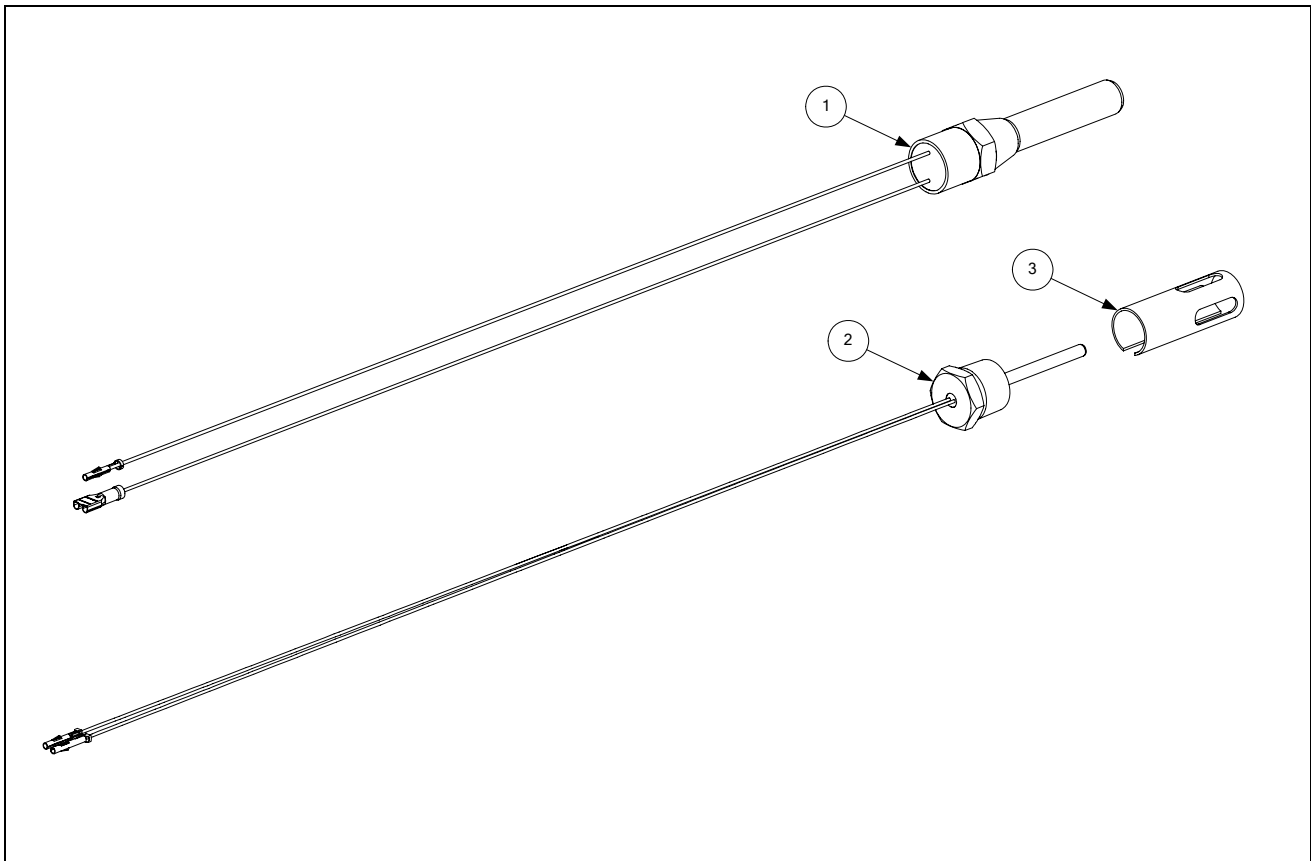

ITEM	PART #	COMPONENT
1	826-1177	Thermostat Assembly, HE FM High-Limit 425°F/218°C
2	806-4206	Temperature Probe
3	210-0681	Probe Guard

2.7 Frypots and Associated Components

2.7.1 Full-Vat Frypot Components

NOTE: All insulation and gaskets can be ordered in a single kit, P/N 826-0929.

Kit 826-0931 contains the insulation and gaskets required when replacing burners (Items 14, 16, 18, and 23).

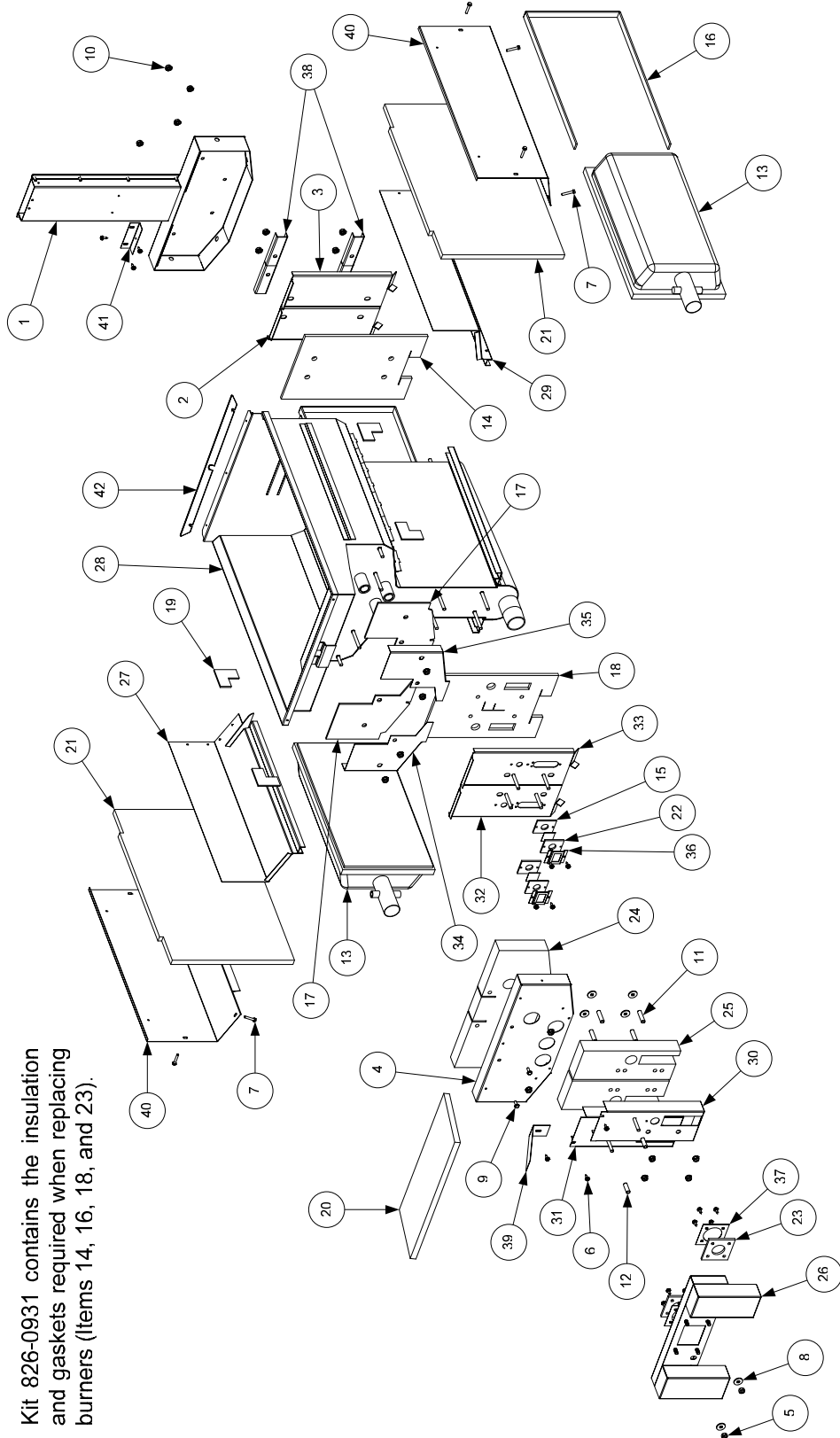

ITEM	PART #	COMPONENT
1	106-1019SP	Flue Assembly, Full-Vat
2	200-0936	Back, Left Full-Vat Combustion Chamber
3	200-0937	Back, Right Full-Vat Combustion Chamber
4	200-2227	Retainer, Full-Vat Upper Insulation
5	826-1372	Nut, ¼-20 Flange Hex (Pkg. of 10)
6	826-1371	Screw, #8 X ½-inch Hex Head Drill Point (Pkg. of 25)
7	809-0362	Screw, #8 X 1¼-inch Hex Washer Head Drill Point
8	826-1383	Washer, Steel (Pkg. of 5)
9	809-0500	Screw, #10 X ½-inch Hex Washer Head 410 SS
10	809-0804	Nut, ¼-20 Keps Hex
11	826-1340	Spacer, .25-inch X 1.187-inch (Pkg. of 10)
12	810-0500	Spacer, .25-inch X .9375-inch
13	826-1072	Burner, Universal Replacement
14	812-0355	Insulation, Full-Vat Lower Rear
15	812-0356	Insulation, Burner Sight Glass
16	816-0577	Insulation, Burner
17	812-0404	Insulation, Left or Right Front Seal
18	812-0457	Insulation, Full-Vat Lower Front
19	812-0706	Insulation, Upper Burner Rail
20	812-0993	Insulation, Upper Oil Zone
21	812-1029	Insulation, Combustion Chamber Side
22	814-0048SP	Glass, Burner Sight
23	816-0057	Gasket, Plenum
24	816-0560	Insulation, Full-Vat Upper Front
25	816-0561	Insulation, Left or Right Outer Front
26	823-0969	Plenum, Full-Vat
27	823-1777	Side and Rail, Left Full-Vat Combustion Chamber
28	823-3323SP	Frypot, Full-Vat 439 SS
29	823-3142	Side and Rail, Right Full-Vat Combustion Chamber
30	823-3304	Front, Full-Vat Right Combustion Chamber
31	823-3305	Front, Full-Vat Left Combustion Chamber
32	823-3315	Retainer, Left Full-Vat Lower Front Insulation
33	823-3316	Retainer, Right Full-Vat Lower Front Insulation
34	824-0863	Retainer, Left Full-Vat Upper Insulation
35	824-0864	Retainer, Right Full-Vat Upper Insulation
36	900-1031	Retainer, Burner Sight Glass
37	900-1049	Retainer, Plenum Gasket
38	900-1221	Retainer, Rear Insulation
39	900-1515	Brace, Upper Oil Zone Insulation
40	900-4452	Retainer, Combustion Chamber Side Insulation
41	930-0818	Bracket, Flue to Frypot
42	900-4253	Strip, Fluecap Retainer
*	910-2474	Pot-to-Pot Gap Clip
*	106-1049SP	Frypot Assembly Full-Vat w/RF HE (NAT)
*	106-1050SP	Frypot Assembly Full-Vat w/RF HE (PRO)
*	106-1053	Frypot Assembly Full-Vat w/RF HE (MFG)
*	826-0929	Insulation Kit, Complete Full-Vat
*	826-0931	Insulation Kit, Burner Full-Vat

* Not Illustrated

2.7.2 Dual-Vat Frypot Components

NOTE: All insulation and gaskets can be ordered in a single kit, P/N 826-0930.

Kit 826-0932 contains the insulation and gaskets required when replacing burners (Items 13, 15, 17, and 23).

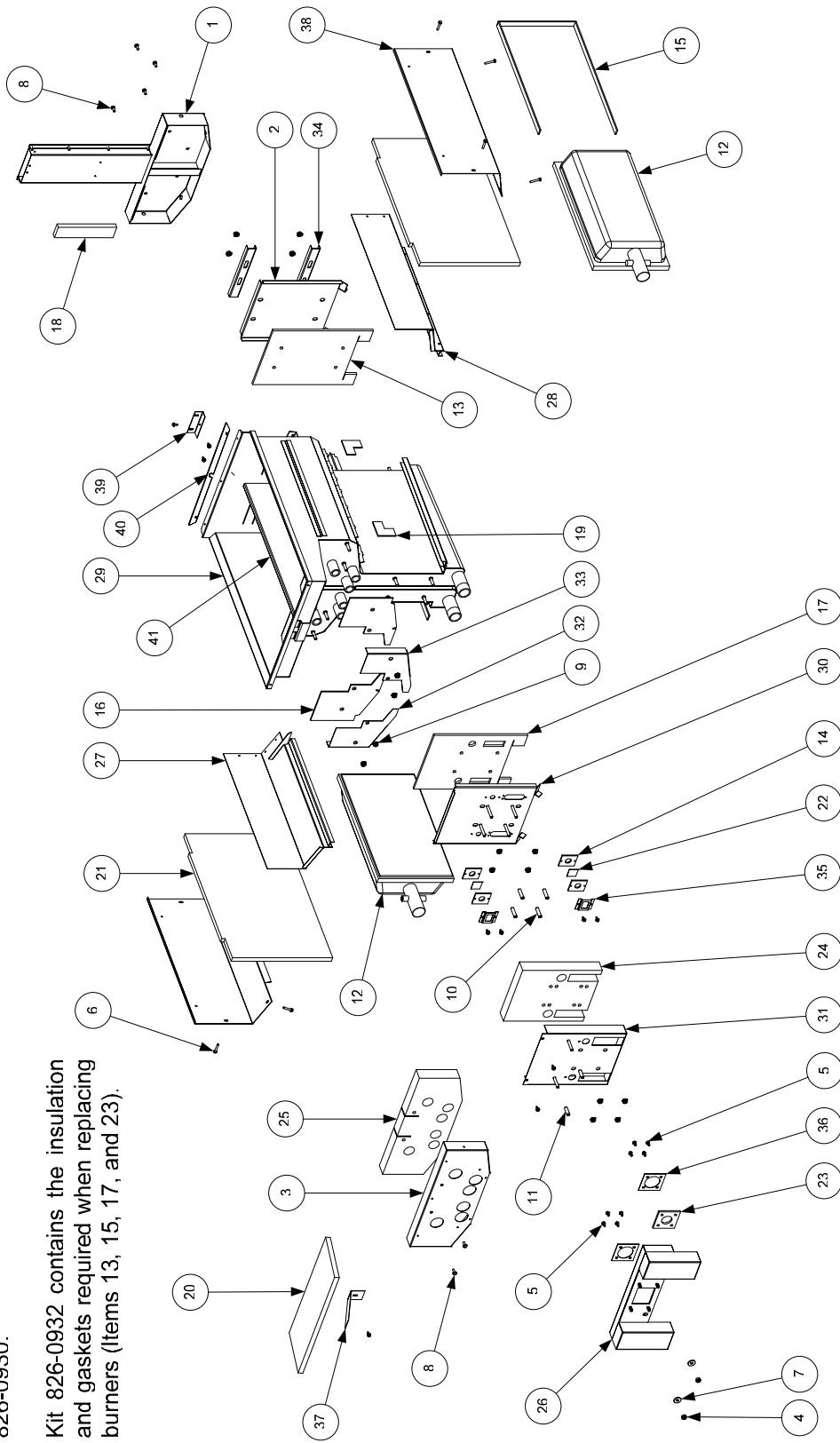

ITEM	PART #	COMPONENT
1	106-1018SP	Flue Assembly, Dual-Vat
2	200-0941	Back, Dual-Vat Combustion Chamber
3	200-2229	Retainer, Dual-Vat Upper Insulation
4	826-1372	Nut, ¼-20 Flange Hex (Pkg. of 10)
5	809-0360	Screw, #8 X ⅜-inch Hex Head
6	809-0362	Screw, #8 X 1¼-inch Hex Washer Head Drill Point
7	826-1383	Washer, Steel (Pkg. of 5)
8	809-0500	Screw, #10 X ½-inch Hex Washer Head 410 SS
9	809-0804	Nut, ¼-20 Keps Hex
10	826-1340	Spacer, .25-inch X 1.187-inch (Pkg. of 10)
11	810-0500	Spacer, .25-inch X .9375-inch
12	826-1072	Burner, Universal Replacement
13	812-0354	Insulation, Dual-Vat Lower Rear
14	812-0356	Insulation, Burner Sight Glass
15	816-0577	Insulation, Burner
16	812-0404	Insulation, Left or Right Front Seal
17	812-0458	Insulation, Dual-Vat Lower Front
18	812-0688	Insulation, Flue Collector
19	812-0706	Insulation, Upper Burner Rail
20	812-0993	Insulation, Upper Oil Zone
21	812-1029	Insulation, Combustion Chamber Side
22	814-0048SP	Glass, Burner Sight
23	816-0057	Gasket, Plenum
24	816-0558	Insulation, Dual-Vat Lower Front
25	816-0559	Insulation, Dual-Vat Upper Front
26	823-0970	Plenum, Dual-Vat
27	823-2822	Side and Rail, Left Dual-Vat Combustion Chamber
28	823-2823	Side and Rail, Right Dual-Vat Combustion Chamber
29	823-3324SP	Frypot, Dual-Vat 439 SS
30	823-3302	Front, Dual-Vat Combustion Chamber
31	823-3303	Retainer, Dual-Vat Lower Front Insulation
32	824-0865	Retainer, Left Dual-Vat Upper Insulation
33	824-0866	Retainer, Right Dual-Vat Upper Insulation
34	900-0914	Retainer, Lower Rear Insulation
35	900-1031	Retainer, Burner Sight Glass
36	900-1049	Retainer, Plenum Gasket
37	900-1515	Brace, Upper Oil Zone Insulation
38	900-4452	Retainer, Combustion Chamber Side Insulation
39	930-0818	Bracket, Flue to Frypot
40	900-4253	Strip, Fluecap Retainer
41	824-0541	Riser, DV Pot Divider W/A
*	910-2474	Pot-to-Pot Gap Clip
*	106-1079SP	Frypot Assembly Dual-Vat w/RF HE (NAT)
*	106-1080SP	Frypot Assembly Dual-Vat w/RF HE (PRO)
*	106-1070	Frypot Assembly Dual-Vat w/RF HE (MFG)
*	826-0930	Insulation Kit, Complete Dual-Vat
*	826-0932	Insulation Kit, Burner Dual-Vat

* Not Illustrated

2.8 Gas Supply and Combustion System Components

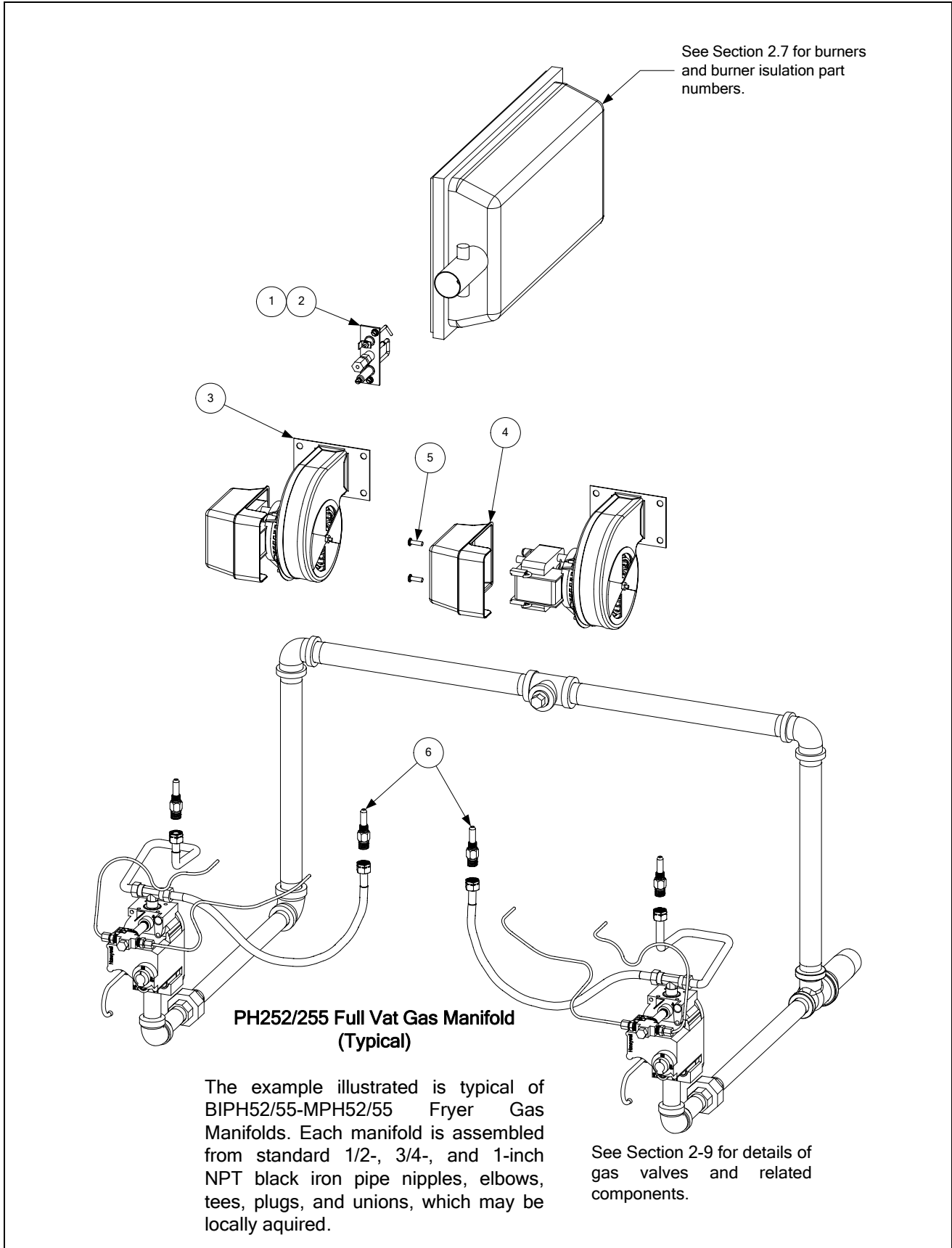

ITEM	PART #	COMPONENT
1		Ignitor (includes gasket 816-0059 , which may be ordered separately)
	826-0981	Natural Gas (G20, G25)
	826-0982	Propane (G30, G31)
	826-1002	Manufactured Gas
2	826-1371	Screw, #8 X ½-inch Hex Head (Pkg. of 25)
3		Blower Assembly, Combustion Air (includes harness and Items 4, and 5)
	106-2996SP	100V 50/60 Hz (Left)
	106-2999SP	100V 50/60 Hz (Right)
	106-2994SP	115V 50/60 Hz. (Left)
	106-2997SP	115V 50/60 Hz (Right)
	106-2995SP	208-240V 50/60 Hz (Left)
	106-2998SP	208-240V 50/60 Hz (Right)
	106-3000SP	230V 50/60 Hz CE (Left)
	106-3001SP	230V 50/60 Hz CE (Right)
4	816-0554	Cover, Blower Motor (component of all blowers listed above)
5	809-0938	Screw, 10-32 X ⅝-inch Philips Truss Head (secures Item 4 to Item 3)
*	806-8806SP	Harness Assembly, Blower Motor (component of all blowers listed above)
6		Orifice, Burner
	812-1137	1.95 mm Propane/Butane (G30, G31) (0-4999 Ft, 0-1524 M) (CE)
	810-1221	2.00 mm Propane/Butane (0-4999 Ft, 0-1524 M) (Japan only)
	810-0386	2.10 mm Propane/Butane (0-4999 Ft, 0-1524 M)
	810-0413	2.16 mm Propane/Butane (G30, G31) (5000-6999 Ft, 1525-2133 M)
	812-1028	2.20 mm Propane/Butane (G30, G31) (7000-10,999 Ft, 2134-3352 M)
	812-1134	3.10 mm Natural Gas (G20, G25) (0-4999 Ft, 0-1524 M) (Japan only)
	810-0403	3.40 mm Natural Gas (G20, G25) (0-4999 Ft, 0-1524 M)
	810-0437	3.60 mm Natural Gas (G20, G25) (5000-6999 Ft, 1525-2133 M)
	812-1144	3.65 mm Natural Gas (G20, G25) (7000-8999 Ft, 2134-2743 M)
	812-1145	3.70 mm Natural Gas (G20, G25) (9000-10,999 Ft, 2744-3352 M)
	810-0642	5.95 mm Manufactured Gas (0-4999 Ft, 0-1524 M)
*	826-1196	Conversion Kit, Natural Gas (G20, G25) to Propane/Butane (G30, G31) CE only
*	826-1197	Conversion Kit, Propane/Butane (G30, G31) to Natural Gas (G20, G25) CE only
*	807-2263	Switch, Air Pressure (<i>use 807-2262 in units with 100VAC power supply</i>)

* Not illustrated.

2.9 Gas Valves and Associated Components

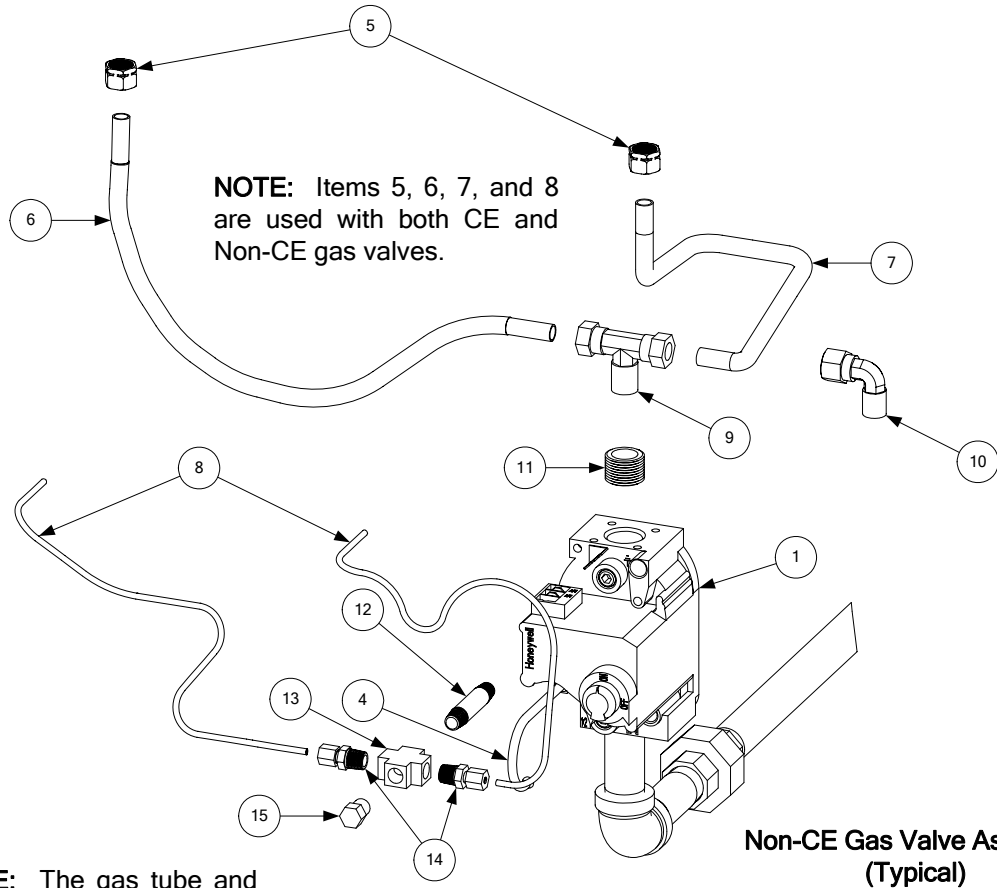

**Non-CE Gas Valve Assembly
(Typical)**

NOTE: The gas tube and enrichment tube fittings are assembled in varying configurations depending upon the location of the valve and whether the associated frypot is a full- or a dual-vat pot.

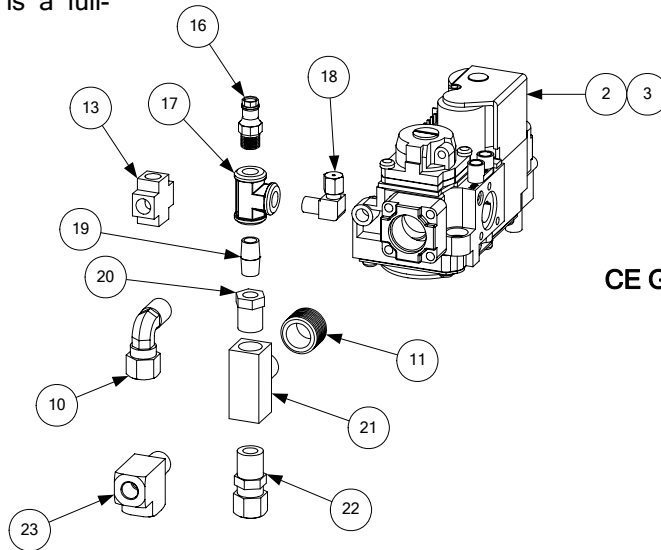

**CE Gas Valve Assembly
(Typical)**

ITEM	PART #	COMPONENT
1		Valve, Non-CE Gas
	826-1122	Natural Gas (G20, G25)
	826-1120	Kit Natural Gas w/ flexlines and hardware
	826-1123	Propane Gas (G30, G31)
	826-1121	Kit, Propane Gas w/ flexlines and hardware
2	810-1715	Valve, CE Gas (G20, G25, G30, G31)
3	810-1041	Accessory Kit (contains parts to adapt Item 2 to specific fryer configuration)
4	810-0691	Tube, 1/8-inch Vent
5	810-0494	Ferrule (Nut), Orifice
6	810-1355	Gas Line, 3/8-inch OD X 15-inch SS Flexible
7	810-1354	Gas Line, 3/8-inch OD X 12-inch SS Flexible
	810-1353	Gas Line, 3/8-inch OD X 9-inch SS Flexible (Used on some split pot applications)
8	811-0800	Tube, 1/8-inch OD X 12.5-inch Enrichment (cut and form to fit)
9	813-0301	Tee, 1/4-inch Male NPT to 3/8-inch Tube
10	813-0302	Elbow, 1/4-inch Male NPT to 3/8-inch Tube 90° (used on DV valve)
11	813-0304	Bushing, 1/2-inch NPT to 1/4-inch NPT Flush Reducing
12	813-0405	Nipple, 1/8-inch NPT X 2-inch
13	813-0378	Fitting, 1/8-inch NPT Cross
14	813-0340	Adapter, 1/8-inch NPT to 1/8-inch Tube
15	813-0154	Plug, 1/8-inch NPT Hex Head Pipe
16	810-1176	Tap, 1/8-inch NPT Pressure
17	813-0377	Tee, 1/8-inch NPT Female
18	813-0354	Elbow, 1/8-inch NPT X 1/8-inch Tube Compression
19	813-0016	Nipple, 1/8-inch NPT X Close
20	810-1006	Bushing, 1/4-inch NPT to 1/8-inch NPT Reducing
21	813-0495	Tee, 1/4-inch Male NPT to Female NPT
22	810-1025	Connector, 1/4-inch Male NPT to 3/8-inch Tube
23	810-1026	Tee, 1/4-inch Male NPT to Female NPT Street

2.10 Wiring Assemblies and Harnesses

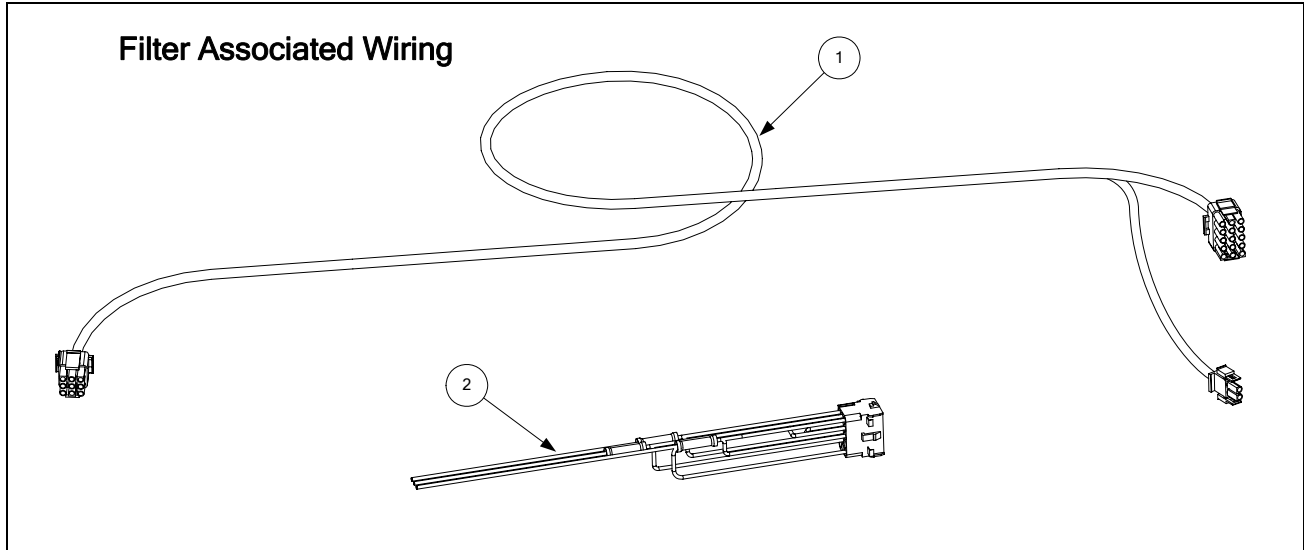

ITEM	PART #	COMPONENT
1	807-3584	Cable, Filter Lower 9-Pin Plug to 807-2001 15-Pin (C2) Connector
2	807-2001	Cable, 810-3584 15-Pin C2 Connector to Component Box

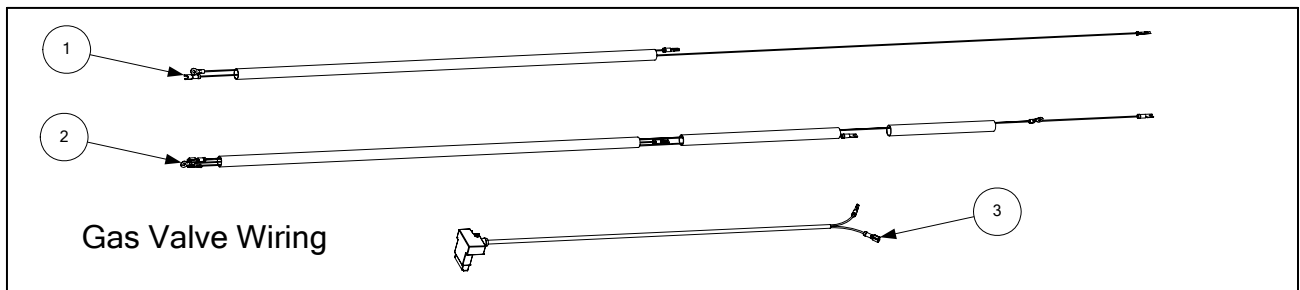

ITEM	PART #	COMPONENT
1	806-3941SP	Harness, Full Vat Gas Valve
2	806-3940SP	Harness, Dual Vat Gas Valve
3	806-9678SP	Plug Assembly, CE Gas Valve

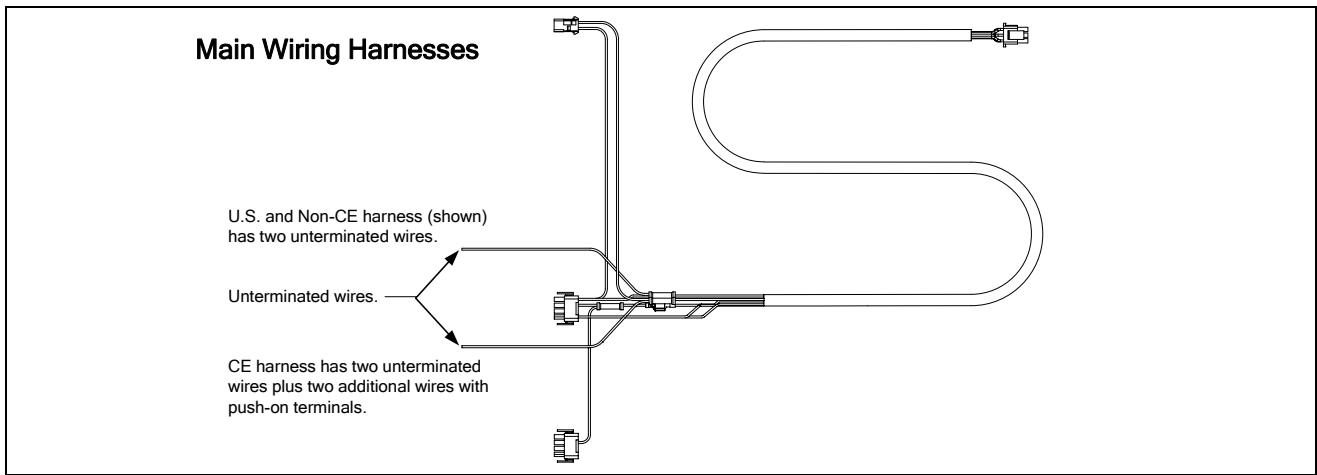

ITEM	PART #	COMPONENT
	807-1978	U.S. and Non-CE Export Main Wiring Harness
	807-2168	CE Main Wiring Harness

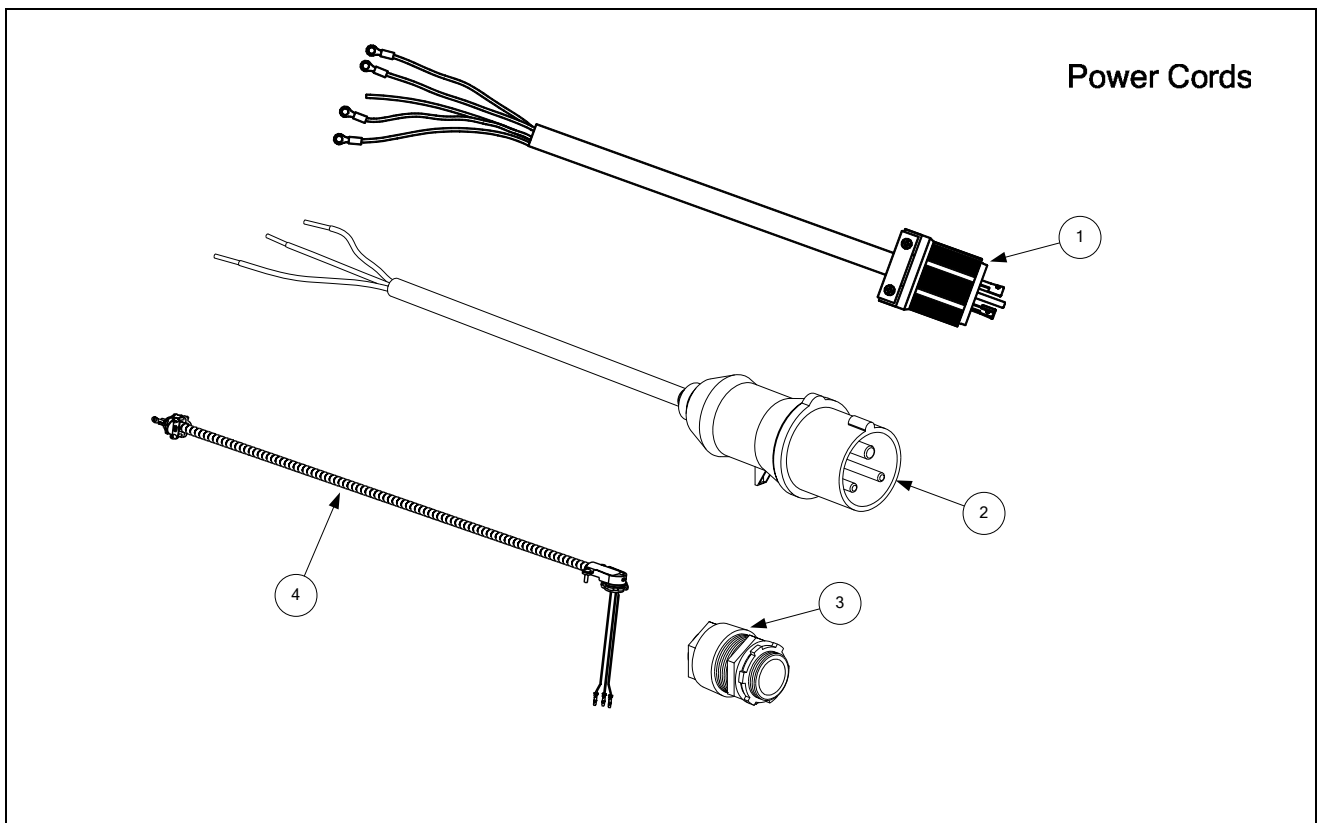

ITEM	PART #	COMPONENT
1	806-6083	Power Cord, 120V w/Grounding Plug 5 wire (w/Ring Terminals, no Clamp)
2	807-1696	Power Cord, CE
3	807-1560	Strain Relief
4	106-1020	Pump Motor to Transfer Box Wiring Assembly

Transformer Box Cable Assemblies

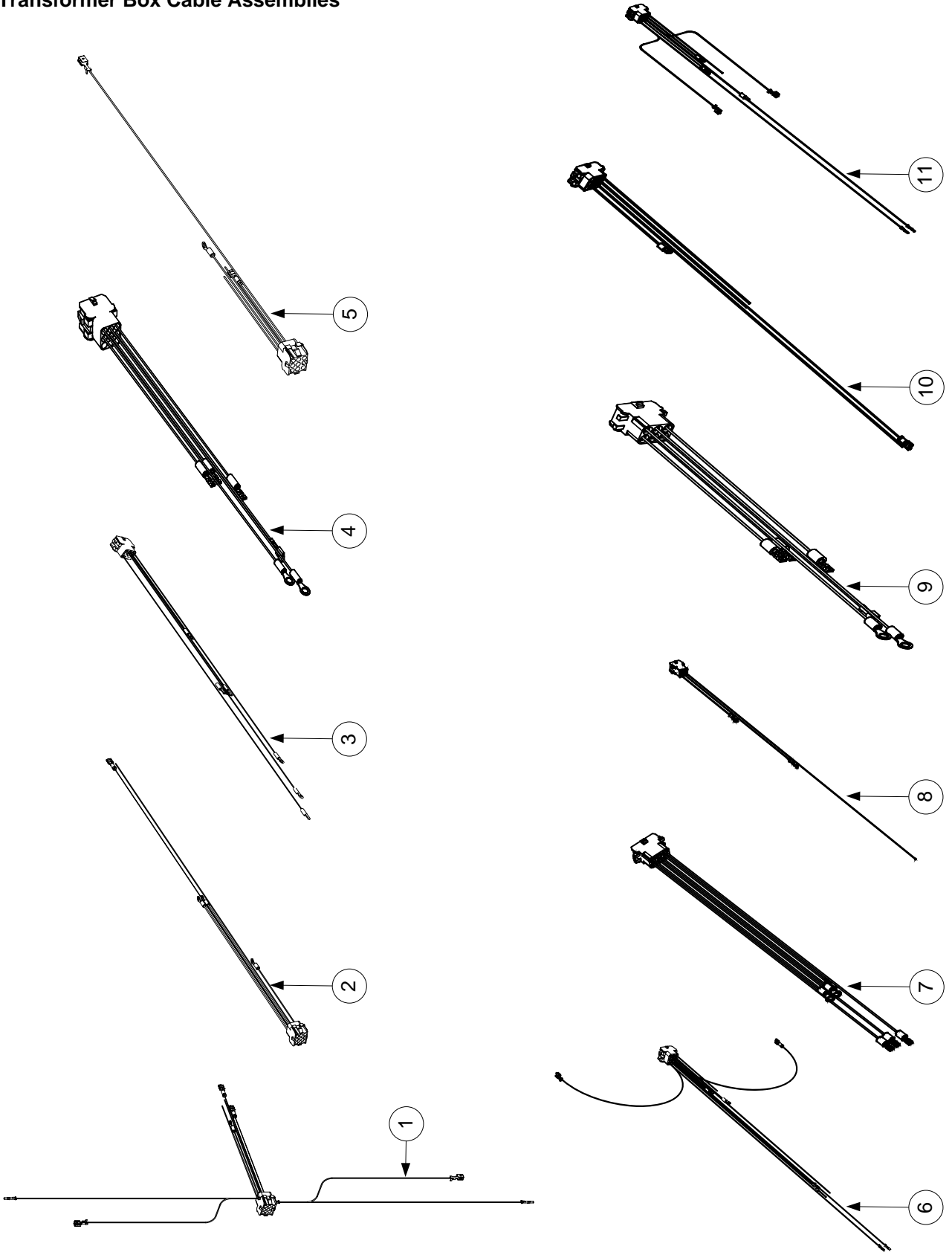

ITEM	PART #	COMPONENT
1	106-1011	Cable Assembly, Transformer Box Line (See NOTE 1)
2	106-1016	Cable Assembly, Transformer Box to Filter Pump (See NOTE 2)
3	106-3821	Cable Assembly, Transformer Box #2 Position (See NOTE 7)
4	106-3820	Cable Assembly, Transformer Box #1 Position (See NOTE 3)
5	106-3316	Cable Assembly, Transformer Box Line (See NOTE 4)
6	106-4990	Cable Assembly, Transformer Box Line (See NOTE 8)
7	106-3825	Cable Assembly, Transformer Box #3 Position (See NOTE 5)
8	106-3826	Cable Assembly, Transformer Box to Filter Pump (See NOTE 5)
9	106-3827	Cable Assembly, Transformer Box #1 Position (See NOTE 5)
10	106-4894	Cable Assembly, Transformer Box to Filter Pump (See NOTE 6)
11	106-4893	Cable Assembly, Transformer Box Line (See NOTE 6)

NOTE 1: Item 1 is used in transformer boxes B and D on page 2-19.

NOTE 2: Item 2 is used in transformer boxes A, B and D on page 2-19.

NOTE 3: Item 4 is used in transformer boxes A, B, D and E on page 2-19.

NOTE 4: Item 5 is used in transformer boxes C and F on pages 2-19 and 2-20.

NOTE 5: Items 7, 8 and 9 are used in transformer boxes C, F and G on pages 2-19 and 2-20.

NOTE 6: Items 10 and 11 are used in transformer box E on page 2-19.

NOTE 7: Item 3 is used in transformer boxes A-F on pages 2-19 and 2-20.

NOTE 8: Item 6 is used in transformer box G on page 2-20.

2.11 Miscellaneous Connectors and Terminals

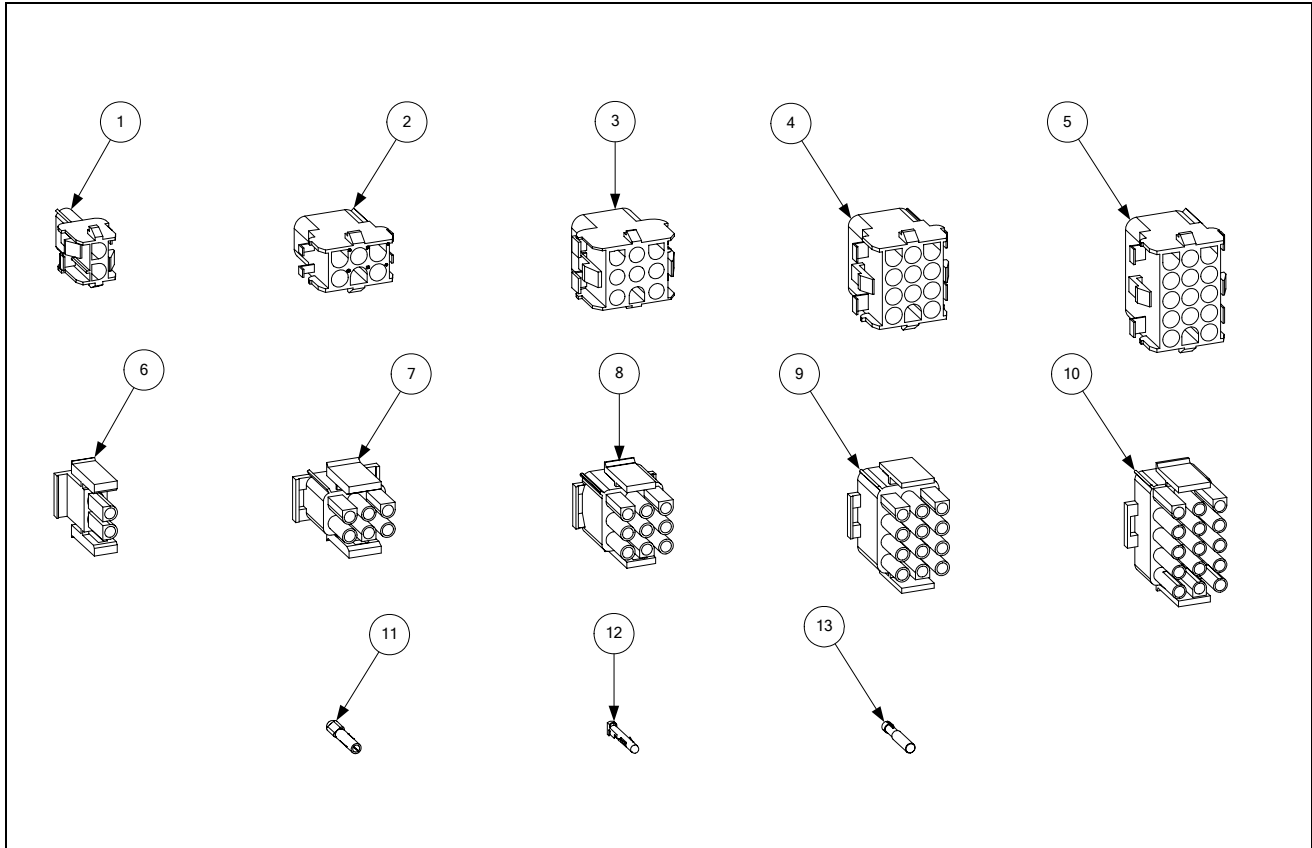

ITEM	PART #	COMPONENT
1	807-1068	2-Pin Female
2	807-0158	6-Pin Female
3	807-0156	9-Pin Female
4	807-0159	12-Pin Female
5	807-0875	15-Pin Female
6	807-1067	2-Pin Male
7	807-0157	6-Pin Male
8	807-0155	9-Pin Male
9	807-0160	12-Pin Male
10	807-0804	15-Pin Male
11	826-1341	Terminal, Female Split Pin (Pkg of 25)
12	826-1342	Terminal, Male Split Pin (Pkg of 25)
13	807-2518	Plug, Mate-N-Lock (Dummy Pin)

* Not illustrated.

THIS PAGE INTENTIONALLY LEFT BLANK



Enodis[®]

One Company. Countless Solutions

Frymaster, L.L.C., 8700 Line Avenue, PO Box 51000, Shreveport, Louisiana 71135-1000
Shipping Address: 8700 Line Avenue, Shreveport, Louisiana 71106

TEL 1-318-865-1711 FAX (Parts) 1-318-219-7140 FAX (Tech Support) 1-318-219-7135

PRINTED IN THE UNITED STATES

SERVICE HOTLINE
1-800-551-8633

819-6094
MAY 2006