



FGP55 Rethermalizer

Service & Parts Manual

Frymaster[®]

NON-CE &



Dean, a member of the Commercial Food Equipment Service Association, recommends using CFESA Certified Technicians.

24-Hour Service Hotline

1-800-551-8633

Email: service@frymaster.com

www.frymaster.com

09/2023



8 1 9 6 2 5 0

Please read all sections of this manual and retain for future reference.

This product has been certified as commercial cooking equipment and **MUST** be installed by professional personnel as specified. Installation, maintenance and repairs should be performed by your FRYMASTER FACTORY AUTHORIZED SERVICE CENTER.

 **DANGER**

Do not store or use gasoline or other flammable vapors and liquids in the vicinity of this or any other cooking appliance.

 **DANGER**

Instructions explaining procedures to be followed **MUST** be posted in a prominent location in the event the operator detects a gas leak. This information can be obtained from the local gas company or gas supplier.

 **DANGER**

Safe and satisfactory operation of your equipment depends on proper installation. Installation **MUST** conform with local codes, or in absence of local codes, with the National Fuel Gas Code, ANSI Z223.1; The Natural Gas Installation Code, CAN/CGA-B149.1; The Propane Installation Code, CAN/CGA-B149.2; or The latest edition of the National Electric Code, N.F.P.A. 70.

NOTICE

If, during the warranty period, the customer uses a part for this Frymaster Dean equipment other than an unmodified new or recycled part purchased directly from Frymaster Dean, or any of its authorized service centers, and/or the part being used is modified from its original configuration, this warranty will be void. Further, Frymaster Dean and its affiliates will not be liable for any claims, damages or expenses incurred by the customer which arise directly or indirectly, in whole or in part, due to the installation of any modified part and/or part received from an unauthorized service center.

 **DANGER**

The front ledge of the rethermalizer is not a step. Do not stand on the rethermalizer. Serious injury can result from slips or contact with the hot water.

 **WARNING**

Drawings and photos used in this manual are intended to illustrate operational, cleaning and technical procedures and may not conform to on-site management operational procedures.

 **WARNING**

No structural material on the rethermalizer should be altered or removed to accommodate placement of the rethermalizer under a hood. Questions? Call the Frymaster Dean Service Hotline at 1-800-551-8633.

NOTICE

This equipment is to be installed in compliance with the basic plumbing code of The Building Officials and Code Administrators International, Inc. (BOCA) and the Food Service Sanitation Manual of the Food and Drug Administration.

NOTICE

The Commonwealth of Massachusetts requires any and all gas products to be installed by a licensed plumber or pipe fitter.

COMPUTERS
FCC

This device complies with Part 15 of the FCC rules. Operation is subject to the following two conditions: 1) This device may not cause harmful interference, and 2) This device must accept any interference received, including interference that may cause undesired operation. While this device is a verified Class A device, it has been shown to meet the Class B limits.

CANADA

This digital apparatus does not exceed the Class A or B limits for radio noise emissions as set out by the ICES-003 standard of the Canadian Department of Communications.

Cet appareil numérique n'émet pas de bruits radioélectriques dépassant les limites de classe A et B prescrites dans la norme NMB-003 édictée par le Ministre des Communications du Canada.

 **DANGER**

THIS PRODUCT CONTAINS CHEMICALS KNOWN TO THE STATE OF CALIFORNIA TO CAUSE CANCER AND/OR BIRTH DEFECTS OR OTHER REPRODUCTIVE HARM.

Operation, installation, and servicing of this product could expose you to airborne particles of glasswool or ceramic fibers, crystalline silica, and/or carbon monoxide. Inhalation of airborne particles of glasswool or ceramic fibers is known to the State of California to cause cancer. Inhalation of carbon monoxide is known to the State of California to cause birth defects or other reproductive harm.

 **WARNING**

Do not bang rethermalizer baskets or other utensils on the rethermalizer's joiner strip. The strip is present to seal the joint between the cookpot vessels. Banging rethermalizer baskets on the strip will distort the strip, adversely affecting its fit. It is designed for a tight fit and should only be removed for cleaning.

 **DANGER**

Improper installation, adjustment, maintenance or service, and unauthorized alterations or modifications can cause property damage, injury, or death. Read the installation, operating and service instructions thoroughly before installing or servicing this equipment. Only qualified service personnel may convert this appliance to use a gas other than that for which it was originally configured.

 **DANGER**

Adequate means must be provided to limit the movement of this appliance without depending upon the gas line connection or transmitting stress to the electrical conduit. Single rethermalizers equipped with legs must be stabilized by installing anchor straps. All rethermalizers equipped with casters must be stabilized by installing restraining chains. If a flexible gas line is used, an additional restraining cable must be connected at all times when the rethermalizer is in use.

Frymaster[®]

FGP55 Series Rethermalizers Service & Parts Manual

TABLE OF CONTENTS

	Page #
1. SERVICE PROCEDURES	1-1
1.1 Functional Description	1-1
1.2 Accessing Fryers for Service	1-3
1.3 Cleaning the Gas Valve Vent Tube (if applicable)	1-3
1.4 Adjusting Burner Manifold Gas Pressure	1-3
1.5 Adjusting the Pilot Flame	1-4
1.6 Replacing Rethermalizer Components	1-5
1.7 Troubleshooting and Problem Isolation	1-20
1.8 Troubleshooting Guides	1-26
1.8 Probe Resistance Chart	1-29
1.10 Wiring Diagrams	1-30
2. PARTS LIST	2-1
2.1 FGP55 Primary Components	2-2
2.2 Components and Controllers	2-4
2.3 Float Switch Assemblies	2-6
2.4 Control Boxes	2-7
2.5 Incoming Water Plumbing	2-9
2.6 Drain and Associated Parts	2-10
2.7 Gas Plumbing	2-11
2.8 Fasteners	2-12

FGP55 SERIES GAS RETHERMALIZERS

CHAPTER 1: SERVICE PROCEDURES

1.1 Functional Description

FGP55 Series gas rethermalizers contain a welded stainless steel cookpot that is heated by gas flames diffused evenly through tubes built into the cookpot.

Flames originate from orifices in a burner manifold positioned beneath the burners. The burners are positioned in the tube openings, at the front of the cookpot. The diameter of the orifices differs for natural (CE:G20/G25) and LP (CE:G31) gas as indicated in the accompanying table.

NON-CE (Altitudes of 2000 feet or less)							
MODEL	INPUT (BTU)	GAS TYPE	ORIFICE MM (INCH)	ORIFICE PART NO.	QTY	EQUIPMENT PRESSURE	
						MBAR	INCH W.C.
FGP55	90	NAT	2.53(#38)	810-2048	4	10	4
		LP	1.51(#53)	810-2059	4	27.5	11
CE ONLY (Altitudes of 2000 feet or less)							
MODEL	INPUT (kW)	GAS TYPE	ORIFICE MM (INCH)	ORIFICE PART NO.	QTY/ COLOR	EQUIPMENT PRESSURE	
						MBAR	INCH W.C.
FGP55	26.4	G20	2,53	810-2048	4/BLUE	10,0	4,0
		G25	2,53	810-2048	4/BLUE	15,0	6,0
		G31	1,51	810-2059	4/RED	27,0	10,8

An electromechanical gas valve regulates gas flow to the manifold. FGP55 Series gas rethermalizers are equipped with a 24-volt valve system. Current units are configured with an electronic standing pilot system.

Pilot System Configuration

In older units a pilot system comprised of the pilot orifice, pilot hood, and a thermopile were used. The pilot serves two purposes. The first is to light the burner, the second is to heat the thermocouple (some systems incorporate a thermopile). In operation, the thermocouple is in contact with the pilot flame and generates millivolts. The millivolt output energizes the gas valve pilot coil, which in turn opens the pilot valve. If the pilot flame is extinguished, voltage is lost to the gas valve pilot coil and the pilot valve closes. The gas valve is constructed so that the main valve will not open if the pilot valve is not open. The pilot flame must be manually lit when the rethermalizer is first placed into operation. A separate 120-volt circuit, activated by the rethermalizer power switch, provides voltage through the electronic thermostat controller to the gas valve main coil, which opens the main valve.

Electronic Ignition Configuration

In units configured for electronic ignition, an ignition module connected to an ignitor assembly replaces the pilot system. The ignition module performs three important functions: it provides an ignition spark, supplies voltage to the gas valve, and proofs the pilot flame.

FGP55 SERIES GAS RETHERMALIZERS

CHAPTER 1: SERVICE PROCEDURES

Electronic Ignition Configuration (cont.)

The module contains a 60-second time delay circuit and a coil that activates the gas valve. The ignitor assembly consists of a spark plug, a pilot, and a flame sensor element.

At start-up the power switch is placed in the "ON" position, supplying 12 VDC to the heat control circuitry in the computer. Current is supplied to the other leg of the heat relay coil which then closes an electronic switch in the 24 VAC circuit to provide current to the ignition module.

Circuitry in the ignition module sends 24 VAC current to the gas valve via a normally closed high-limit switch and a float switch. Simultaneously, the module causes the ignitor to spark for up to 60 seconds to light the pilot flame. A flame sensor verifies that the pilot is lit by measuring the flow of microamps through the flame. If the pilot does not light (or is extinguished), current to the ignition module is interrupted, preventing the main valve from opening, and the ignition module "locks out" until the power switch is turned "OFF", then back "ON".

A temperature probe monitors the temperature in the cookpot. When the programmed setpoint temperature is reached, resistance in the probe causes the heat cycle circuitry in the controller to interrupt current flow through the heat relay. This in turn interrupts the 24 VAC current to the ignition module, resulting in closure of the gas valve.

Control Options

FGP55 Series gas rethermalizers are equipped with computers. These are unique in that the components are wired directly to the computer and do not require an interface board.

Temperature Probe

FGP55 rethermalizers equipped with computer controls have a *temperature probe*. In this configuration, the probe resistance varies directly with the temperature. That is, as the temperature rises, so does resistance at a rate of approximately 2 ohms for every 1° (°F or °C). Circuitry in the computer monitors the probe resistance and controls burner firing when the resistance exceeds or falls below programmed temperatures (setpoints). The temperatures are programmed by means of a keypad on the face of the computer.

All FGP55 Series gas rethermalizers are equipped with a *high-limit thermostat*. In the event that the rethermalizer fails to properly control the water temperature, the high-limit thermostat prevents the rethermalizer from overheating. The high-limit thermostat acts as a normally closed power switch that opens when exposed to temperatures above 250°F (121°C).

FGP55 SERIES GAS RETHERMALIZERS

CHAPTER 1: SERVICE PROCEDURES

1.2 Accessing Rethermalizers for Servicing

 **DANGER**

Moving a rethermalizer filled with water may cause spilling or splattering of the hot liquid. Follow the draining instructions included with the rethermalizer before attempting to relocate a rethermalizer for servicing.

1. Shut off the gas supply to the unit. Unplug the power cords. Remove any attached restraining devices.
2. Disconnect the unit from the gas supply.
3. Relocate the rethermalizer for service accessibility.
4. After servicing is complete, reconnect the unit to the gas supply, reattach restraining devices, and plug in the electrical cords.

1.3 Cleaning the Gas Valve Vent Tube (if applicable)

1. Set the rethermalizer power switch and the gas valve to the "OFF" position.
2. Carefully unscrew the vent tube from the gas valve. **NOTE:** The vent tube may be straightened for ease in removal.
3. Pass a piece of ordinary binding wire (.052 inch diameter) through the tube to remove any obstruction. Remove the wire and blow through the tube to ensure it is clear.
4. Reinstall tube and bend so that the opening is pointing downward.

1.4 Adjusting Burner Manifold Gas Pressure

 **WARNING**

This task should be performed by qualified service personnel only.

1. Ensure that the gas valve knob is in the "OFF" position.
2. Remove the pressure tap plug from the gas valve (see arrows in photos on the following page for location).

FGP55 SERIES GAS RETHERMALIZERS CHAPTER 1: SERVICE PROCEDURES

1.4 Adjusting Burner Manifold Gas Pressure (cont.)

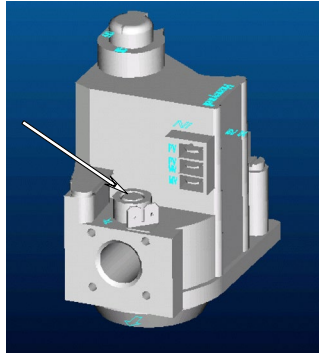

Non-CE Electronic
Ignition Valve

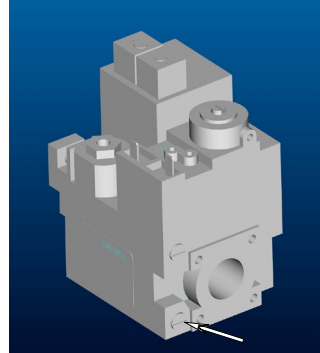

CE Pilot Ignition Valve

3. Insert the fitting for a gas pressure-measuring device into the pressure tap hole.
4. Place the gas valve in the "ON" position then place the rethermalizer power switch in the "ON" position. When the burner lights and continues to burn, note gas pressure reading for correct pressure in accordance with the table on page 1-1.
5. To adjust burner gas pressure, remove the cap from the gas valve regulator and adjust to correct pressure.
6. Place the rethermalizer power switch and the gas valve in the "OFF" position. Remove the pressure-measuring device fitting from the pressure tap hole and reinstall the pressure tap plug.

1.5 Adjusting the Pilot Flame

1. Remove the cap from the pilot adjustment screw hole on the gas valve.
2. Using a small, flat-tipped screwdriver, turn the pilot adjusting screw counterclockwise to increase length of flame or clockwise to decrease length of flame. Adjust to obtain a flame from 1 inch to 1½ inches long.
3. Reinstall the pilot adjustment screw cap.

FGP55 SERIES GAS RETHERMALIZERS

CHAPTER 1: SERVICE PROCEDURES

1.6 Replacing Rethermalizer Components

1.6.1 Replacing the Computer or Solid State Relays

1. Disconnect the rethermalizer from the electrical supply.
2. Unscrew the two computer panel screws. The computer panel is hinged at the bottom and will swing open from the top.

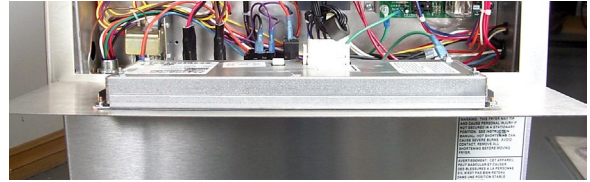

Computer panel in “down” position.

3. Unplug the rethermalizer wiring harness and ground wire from the back of the computer. If replacing the solid-state relays disconnect the wires and replace the faulty relay.

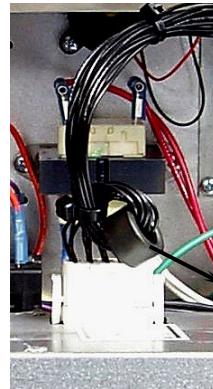

Disconnect the 15-pin connector and ground wire (arrows) from the computer.

4. Remove the computer by lifting it from the hinge slots in the rethermalizer control panel frame.
5. Reverse the procedure to install a new computer.

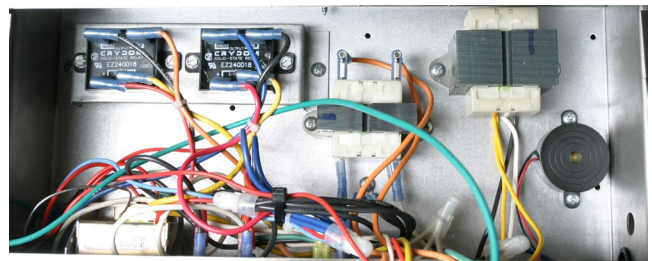

Control panel frame with computer removed.

FGP55 SERIES GAS RETHERMALIZERS

CHAPTER 1: SERVICE PROCEDURES

1.6.2 Replacing the Temperature Probe

1. Disconnect the rethermalizer from the electrical supply.
2. Drain the water from the cookpot. Allow the cookpot to cool completely before proceeding.
3. Remove the rethermalizer door for easier access to the temperature probe. Lift door up, disengage rod from lower door bracket, and then remove door.

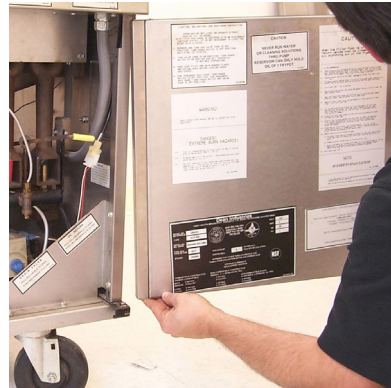

Remove door for easier access to temperature probe.

4. Disconnect the probe harness connector (arrow). Use a pin pusher to remove plug from probe wires (probe side only). Retain the plug for re-assembly on new probe.

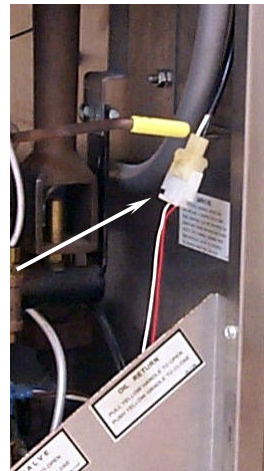

Disconnect the two-pin probe harness connector (arrow).

5. Remove the appropriate burners to gain access to the temperature probe (see Steps 13-14 on page 1-15 for more detail).

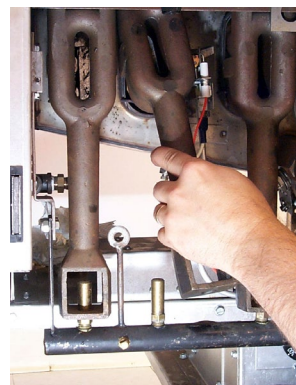

Remove burners to gain access to temperature probe.

FGP55 SERIES GAS RETHERMALIZERS

CHAPTER 1: SERVICE PROCEDURES

1.6.2 Replacing the Temperature Probe (cont.)

6. Loosen and unscrew completely the compression nut, then the pass-through nut from the cookpot. Proceed to the next step before removing probe from cookpot.

Note: The temperature probe can be removed through the top of the cookpot as follows: Ensure the two-pin connector has been removed from the probe wiring harness (step 4, this section). Remove the harness insulation. The probe can be pulled through the cookpot from the top (complete step 7 in this section, prior to removing probe).

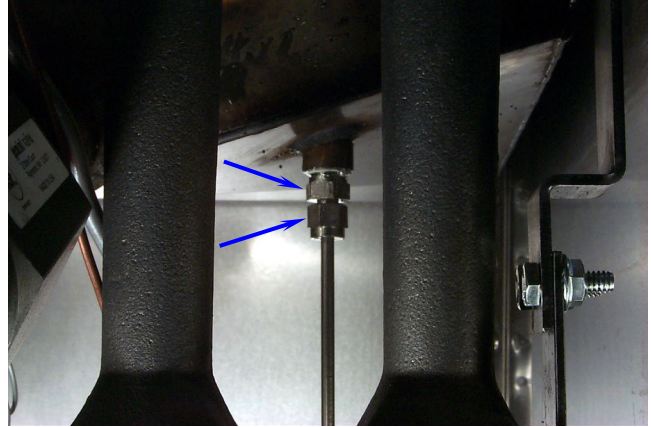

Loosen and unscrew completely the compression nut (bottom arrow), then the pass-through nut (top arrow).

7. Remove probe bracket and probe spring from probe inside cookpot (bracket location and configuration will vary according to rethermalizer model). Retain mounting hardware for installation of new temperature probe.

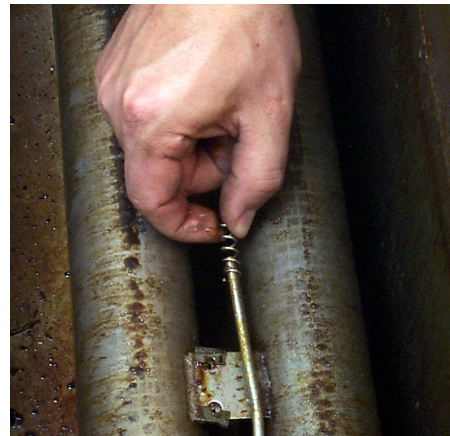

First remove the probe bracket (two screws), then the probe spring. Retain mounting hardware for installation of new probe.

8. Carefully remove the probe from the cookpot. As the probe is removed, tilt the probe at an angle to facilitate removal (curved probes only).

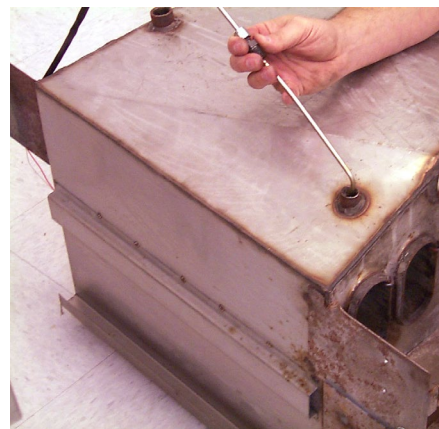

Removing old probe from cookpot. (Cookpot removed from rethermalizer for clarity).

9. Reverse steps for installation of new probe.

IMPORTANT: When installing new probe, ensure probe is positioned properly with the mounting hardware installed prior to tightening the compression nut. **Once tightened, the probe cannot be repositioned.**

FGP55 SERIES GAS RETHERMALIZERS CHAPTER 1: SERVICE PROCEDURES

1.6.3 Replacing the High-Limit Thermostat

1. Turn rethermalizer off and drain water from the cookpot. Allow the cookpot to cool completely before proceeding.
2. Perform steps 1-4 in Section 1.6.1, Replacing the Computer.
3. Remove rethermalizer door for easier access (see Section 1.6.3, Step #3 for more detail).
4. Remove two screws securing the high-limit mounting-bracket. Do not disconnect wires from high-limit at this time.

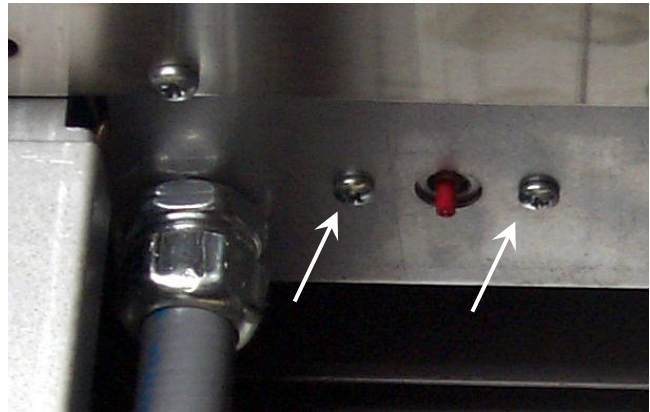

Remove screws (arrows) securing high-limit to rethermalizer.

5. Loosen and completely unscrew the compression nut, then the pass-through nut on the cookpot bottom. Proceed to the next step before removing high-limit from cookpot.

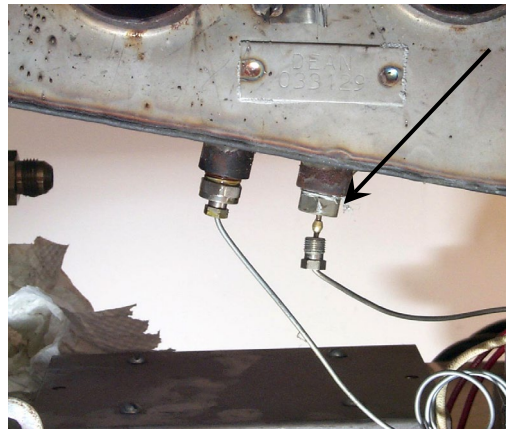

Compression nut unscrewed. Unscrew the pass-through nut (arrow)

FGP55 SERIES GAS RETHERMALIZERS CHAPTER 1: SERVICE PROCEDURES

1.6.3 Replacing the High-Limit Thermostat (cont.)

6. Remove high-limit mounting bracket and high-limit spring inside cookpot. Retain mounting hardware for installation of new high-limit.



Remove high-limit mounting hardware. Retain mounting hardware for installation of new high-limit. (Mounting hardware and location will vary according to rethermalizer model.)

7. Carefully pull high-limit capillary tube and bulb out of the cookpot from the bottom.

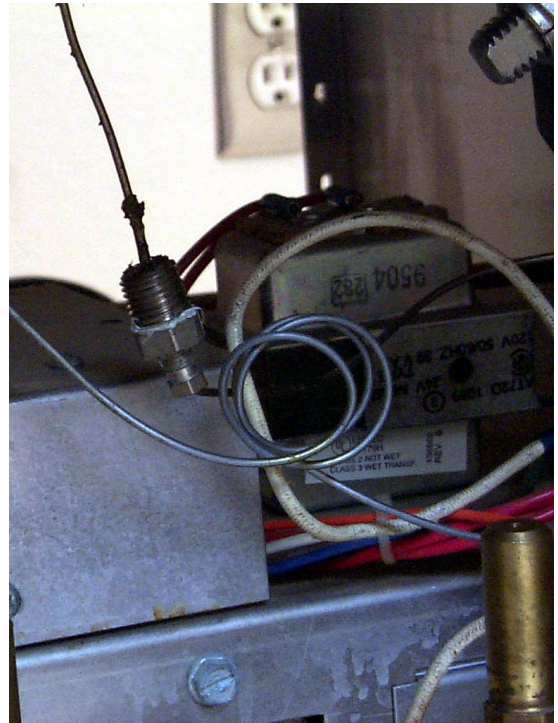

Remove high-limit capillary tube and bulb from the bottom of the cookpot.

FGP55 SERIES GAS RETHERMALIZERS CHAPTER 1: SERVICE PROCEDURES

1.6.3 Replacing the High-Limit Thermostat (cont.)

8. Mark and disconnect wires at the high-limit in the component box.

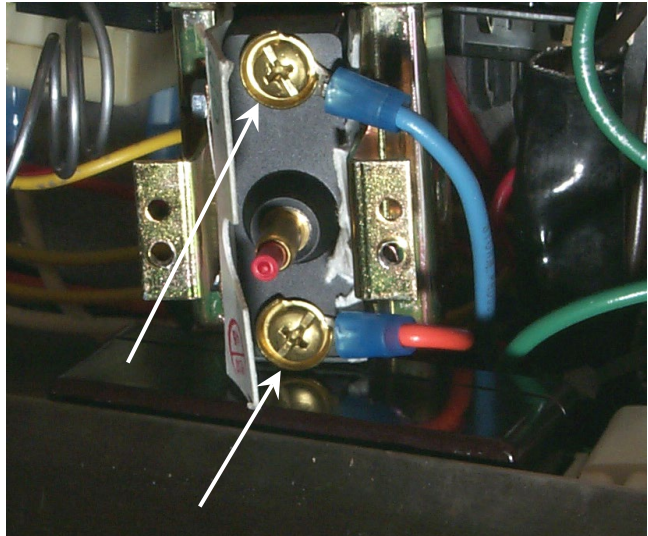

Mark and disconnect high-limit wiring (arrows). (Reconnect wires to the same terminals on the replacement high-limit.)

9. Remove high-limit from rethermalizer by pulling the capillary tube and bulb through the component box opening (arrow). (This may require removal of the control panel frame.)

10. Reverse the above steps for high-limit installation.

IMPORTANT: When installing new high-limit or backup thermostat, ensure the capillary tube and bulb are positioned properly with the mounting hardware installed prior to tightening the compression nut. **Once tightened, the capillary tube cannot be repositioned.**

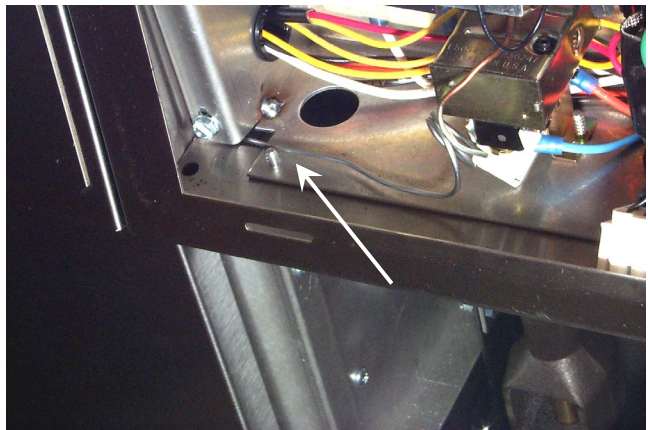

Pull the capillary tube and bulb up and through the component box opening to remove old high-limit. Removing the control panel frame will facilitate high-limit removal. Replace control panel frame after new high-limit has been

FGP55 SERIES GAS RETHERMALIZERS CHAPTER 1: SERVICE PROCEDURES

1.6.4 Replacing Float Switches

1. Disconnect the rethermalizer from the electrical power supply.
2. Drain the water from the cookpot. Allow the cookpot to cool completely before proceeding.
3. Unplug the float switch connector.
4. Remove the clip and float from float switch shaft. (See photo)
5. Loosen and completely unscrew the compression nut from the cookpot.
6. Carefully pull the float switch shaft out of the cookpot.
7. Reverse the above steps for float switch installation.

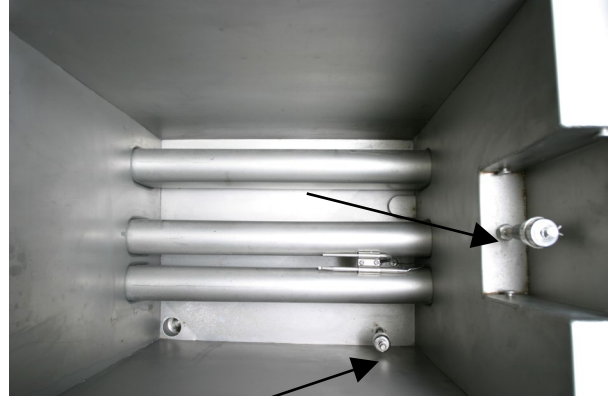

1.6.5 Replacing the Gas Valve



DANGER

Drain the cookpot or remove the handle from the drain valve before proceeding further.

1. Disconnect rethermalizer from electrical and gas supplies.
2. Disconnect the wires from the gas valve terminal block, marking each wire to facilitate reconnections.
3. Remove the high-limit thermostat wire from the gas valve pilot coil.
4. Remove the pilot gas line fitting from the gas valve.
5. Remove the pipe union collars to the left and right of the gas valve and remove the valve.
6. Remove the pipefitting from the old gas valve and install on the replacement valve, using Loctite™ PST567 or equivalent pipe thread sealant on threads. Do not apply sealant to the first two pipe threads. Doing so will clog and damage the gas valve.
7. Reverse steps 1-5 to install the replacement gas valve.

FGP55 SERIES GAS RETHERMALIZERS

CHAPTER 1: SERVICE PROCEDURES

1.6.6 Replacing the Pilot Assembly

1. Remove the pilot tubing from the bottom of the pilot assembly.
2. If the pilot is an electronic ignition pilot, disconnect the ignition cable and the sense wire.
3. Remove the two pilot mounting screws from the pilot mounting-bracket and remove the pilot.
4. Reverse the procedure to replace the pilot assembly.

NOTE: The above procedure is applicable to standing, electronic ignition and trailing pilot assemblies.

1.6.7 Replacing the Cookpot

1. Ensure computer and all power switches are off. Drain water from all cookpots prior to moving rethermalizer.



DANGER

Hot water will cause severe burns. Never attempt to move this appliance when filled with hot water or to transfer hot water from one container to another.

2. Turn gas valve off, then turn gas off at supply valve or meter. Disconnect supply line from gas manifold at rear of rethermalizer.

NOTE: If restraints are installed on the rethermalizer, disconnect restraints prior to disconnecting the gas supply line.

3. Unplug rethermalizer from electrical supply source.
4. Remove rethermalizer door for access to cabinetry components. Lift door up, disengage rod from lower door bracket, remove and set door aside.
5. Remove upper cookpot cover and bracket.
6. Carefully pry up capping strip if disassembling an FGP255 with a screwdriver or similar tool. Remove capping strip and set aside.

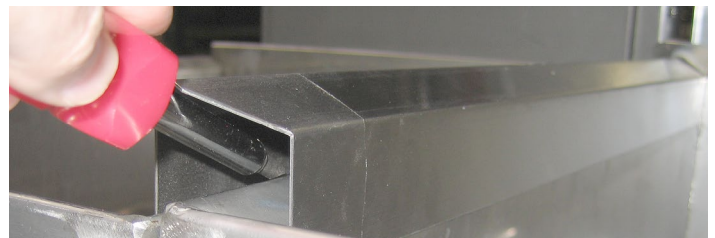

Removing capping strip.

FGP55 SERIES GAS RETHERMALIZERS

CHAPTER 1: SERVICE PROCEDURES

1.6.7 Replacing the Cookpot (cont.)

7. Locate all screws securing back panels. Screw location/orientation will vary according to rethermalizer model.

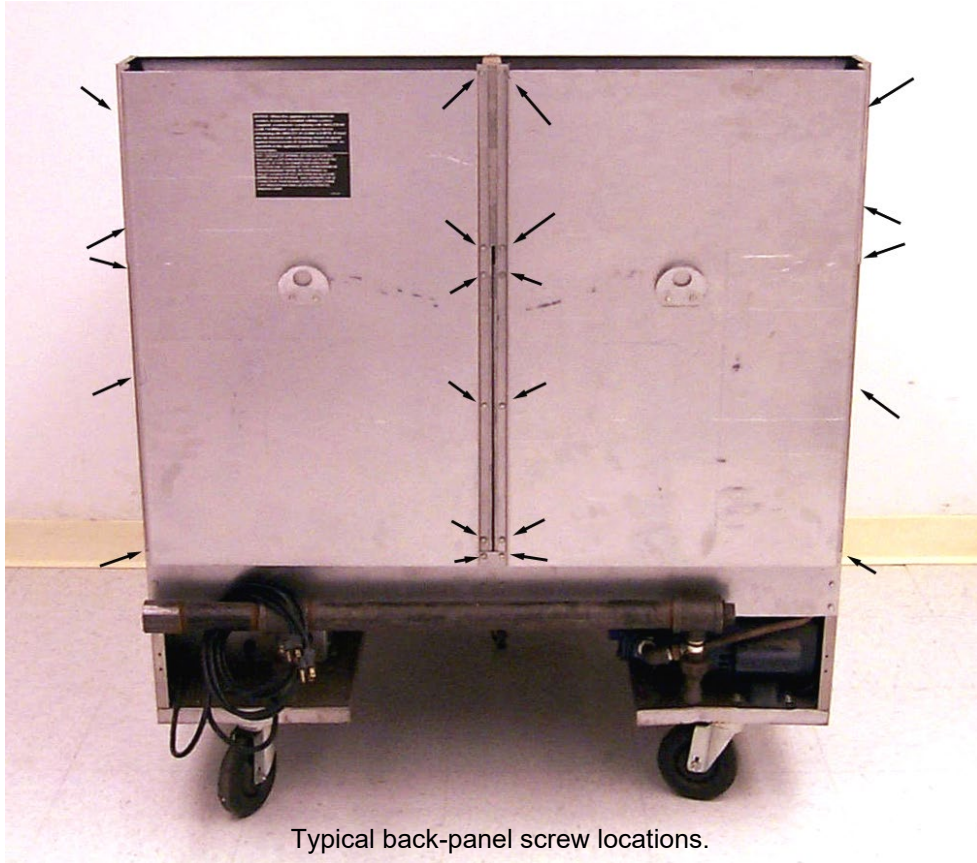

8. Remove back panels on rethermalizer. Retain screws for re-assembly.
9. Remove screw securing back-panel brace to flue cap. Support brace with hand while removing screw to prevent brace from falling away. Remove brace and set aside for reassembly.

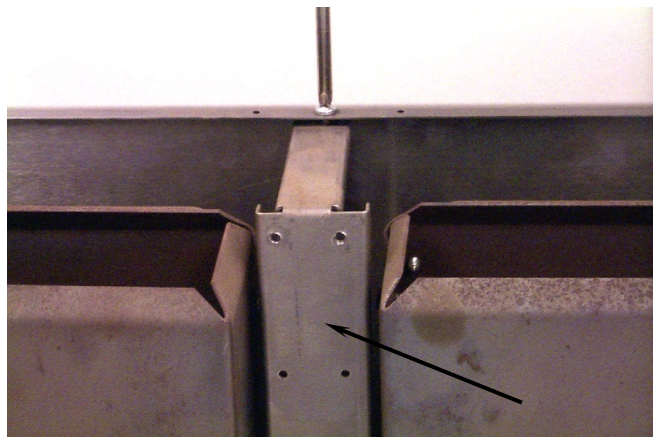

Removing back panel to flue cap brace (arrow).

FGP55 SERIES GAS RETHERMALIZERS CHAPTER 1: SERVICE PROCEDURES

1.6.7 Replacing the Cookpot (cont.)

10. Remove screws securing flue-cap braces to cookpot (a nut-driver with an extension or long screwdriver is required). Use care not to drop the screws into the flues. If this happens, the screws can be retrieved when the flue is removed (Step 12). Use a screwdriver or similar tool to free flue cap from cookpots. Remove flue cap by lifting up and off of rethermalizer.



Removing flue cap.

11. Remove gas manifold pipe for access to gas manifold shield by disconnecting at the unions. Ensure gas supply is shut off and supply line is disconnected prior to removing. Set gas manifold aside. Remove screws securing gas manifold shield. Remove shield to access water-return plumbing components connected to the cookpots.



Removing gas manifold shield.

FGP55 SERIES GAS RETHERMALIZERS CHAPTER 1: SERVICE PROCEDURES

1.6.7 Replacing the Cookpot (cont.)

12. Remove four bolts securing flue to the cookpot being removed. Remove the flue by sliding back and away until clear of cookpot. Retrieve any screws dropped into the flue during removal of the flue cap to cookpot bracket.



Removing bolts (arrows) securing flue to cookpot.

13. Remove the burner shield. Loosen burner bolts (two per burner) that secure burners to the burner support rail.

NOTE: On most rethermalizers, do not remove bolts from burners. Some rethermalizers have an additional bracket that warrants removal of the burner bolts.



Loosening burner bolts prior to burner removal.

14. Lift each burner upward to clear the orifice, then slant the top of the burner inward to clear the burner-brace keyholes.

NOTE: On older FGP55 rethermalizers, the right-center and center burners cannot be removed until the trailing pilot assembly is removed (explained in step 15).

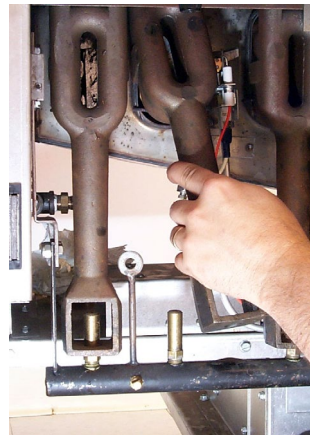

Removing burners from rethermalizer.

FGP55 SERIES GAS RETHERMALIZERS CHAPTER 1: SERVICE PROCEDURES

1.6.7 Replacing the Cookpot (cont.)

Each of the burners is unique in the flame-transfer hole configuration and must be reinstalled correctly:

Left burners (L): Flame transfer hole is on the right side of the burner head.

Center burners (C): Flame transfer hole is on both sides of the burner head.

Right burners (R): Flame transfer hole is on the left side of the burner head.

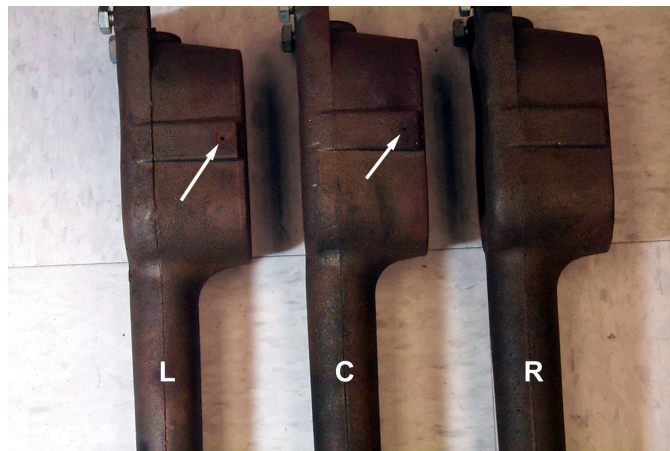
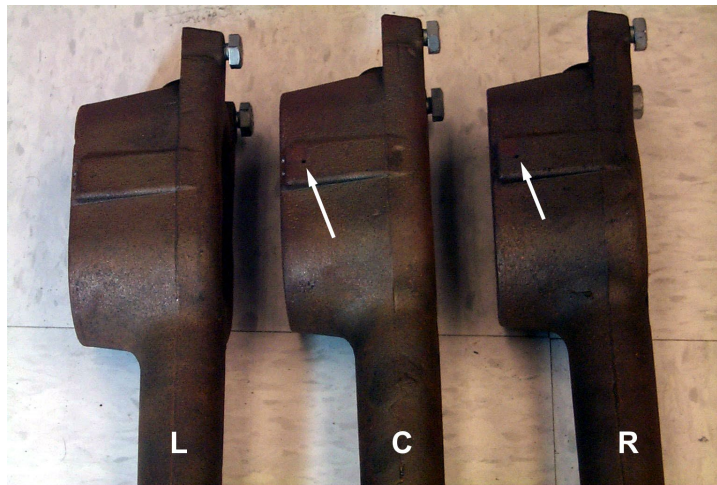

FGP55 SERIES GAS RETHERMALIZERS

CHAPTER 1: SERVICE PROCEDURES

1.6.7 Replacing the Cookpot (cont.)

15. Remove screw(s) securing the electronic or standing pilot bracket to the cookpot bracket. Reposition ignitor assembly down and away from cookpot. Use care not to bend, kink or damage the electronic ignition lines and wiring.

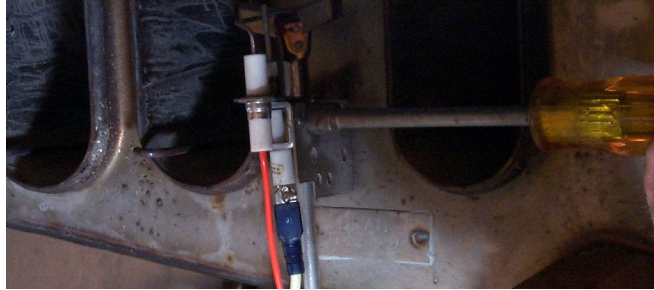

Removing electronic/standing pilot assembly.

NOTE: Remove the trailing pilot assembly on models as follows: Disconnect the pilot supply line from the trailing pilot valve on the burner manifold. Remove the mounting screw(s) as described in Step 15, then remove trailing pilot.

16. Remove cotter pin from drain valve linkage, then disconnect actuator rod from drain valve actuator.

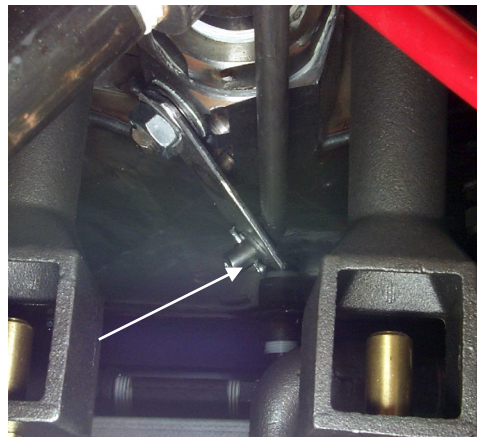

Remove cotter pin (arrow), then disconnect the actuator rod.

17. Remove the temperature probe from cookpot. (see Section 1.6.2, Replacing Temperature Probe for specific instructions).
18. Remove the high-limit (see Steps 5-7, Section 1.6.3- Replacing the High-Limit Thermostat) from cookpot.
19. Disconnect the fresh water line from the cookpot.
20. The rethermalizer is equipped with float-valve switches, mark the wires and terminals, then disconnect wires from the switch. Secure the wires to prevent damage when cookpot is removed.

FGP55 SERIES GAS RETHERMALIZERS CHAPTER 1: SERVICE PROCEDURES

1.6.7 Replacing the Cookpot (cont.)

21. Remove bolts from brackets securing burner manifold to cookpot. Leave the manifold in place.

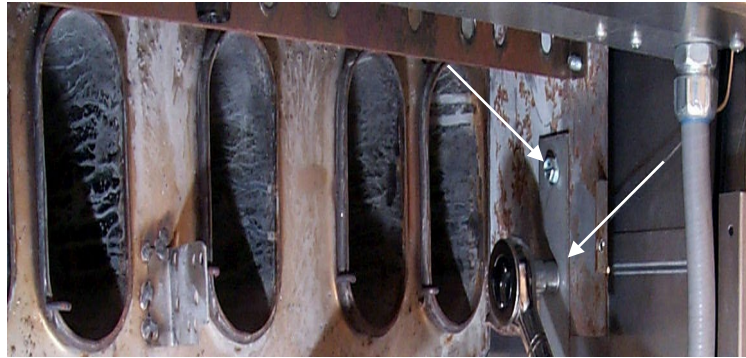

Removing bolts (arrows) from burner manifold support brackets (both sides). Leave the burner manifold in place after removing bolts.

22. Using a sharp knife or box-cutter, cut the silicon seal between and in front of the two cookpots (two-vat or more). Use care not to scratch stainless steel surfaces.



Cutting cookpot seal prior to cookpot removal.

23. Remove cookpot from rethermalizer by lifting up and out.

24. Position the cookpot upside down on a suitable work surface.

25. Record position of the valve stem in relation to the cookpot prior to removing the drain valve. Using a suitable wrench, remove the drain valve from the cookpot. Use Loctite PST567 sealant when installing drain valve on replacement cookpot.



Lifting cookpot from rethermalizer.

26. Reverse the above steps to install replacement cookpot.

FGP55 SERIES GAS RETHERMALIZERS

CHAPTER 1: SERVICE PROCEDURES

1.6.8 Annotated Cookpot Bottom

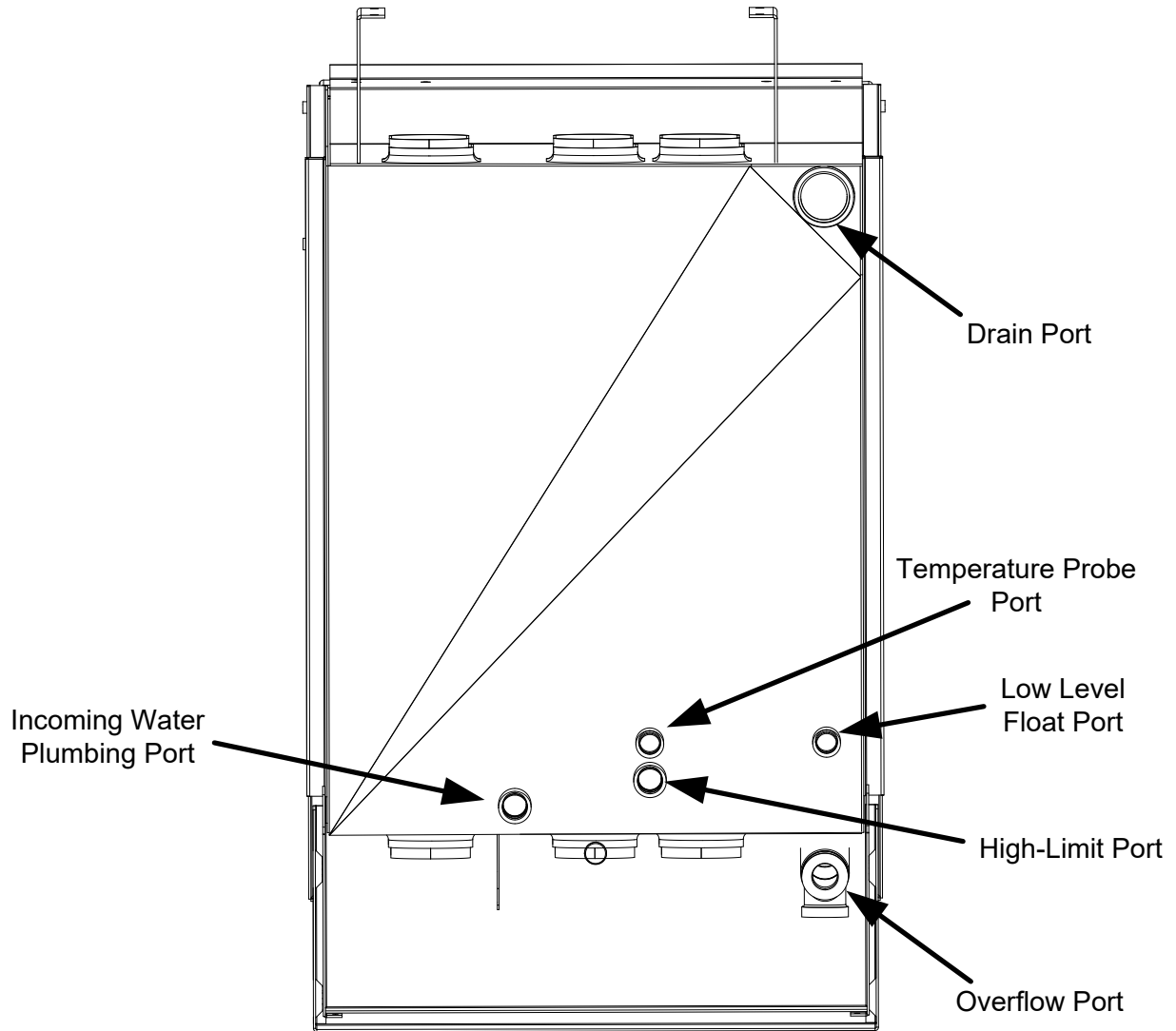

FGP55 SERIES GAS RETHERMALIZERS

CHAPTER 1: SERVICE PROCEDURES

1.7 Troubleshooting and Problem Isolation

This section is intended to provide technicians with a general knowledge of the broad problem categories associated with this equipment, and the probable causes of each. With this knowledge, the technician should be able to isolate and correct any problem encountered.

Problems you are likely to encounter can be grouped into seven broad categories:

1. Ignition failures
2. Improper burner functioning
3. Improper temperature control
4. Computer-related problems
5. Leakage

The probable causes of each category are discussed in the following sections. Troubleshooting guides are included in **Section 1.8** to assist in identifying some of the more common problems.

1.7.1 Ignition Failures

Ignition failure occurs when the ignition module fails to sense a flame within the 60-second time delay period and locks out. Turn the rethermalizer off, locate and fix the problem, then turn rethermalizer back on to clear the module lock.

There are three primary reasons for ignition failure, listed in order of probability:

1. Problems related to the gas and/or electrical power supplies.
2. Problems related to the electronic circuits.
3. Problems related to the gas valve.

Problems Related to the Gas and/or Electrical Power Supplies

The main indicators of this are that an entire battery of rethermalizers fails to light. Verify that the quick disconnect hose is properly connected, the rethermalizer is connected to power, the main gas supply valve is open, and the circuit breaker for the rethermalizer electrical supply is not tripped. Some rethermalizers are equipped with a rethermalizer reset-switch that must be reset each time the rethermalizer is turned off.

FGP55 SERIES GAS RETHERMALIZERS

CHAPTER 1: SERVICE PROCEDURES

1.7.1 Ignition Failures (cont.)

Problems Related to the Electronic Circuits

If gas and electrical power are supplied to the rethermalizer, the next most likely cause of ignition failure is a problem in the 24 VAC circuit. First verify that the float switch valve is fully closed and not sticking. (The float switch must be closed for power to reach the gas valve. Often, a starch build up will cause the float switch to stick, impeding movement up and down the shaft. Simple cleaning of the shaft will fix the problem.) If the float switch is fully closed refer to the troubleshooting guides in this chapter.

Problems Related to the Gas Valve

If the problem is not in the 24 VAC circuit or pilot system, it is most likely in the gas valve itself, but before replacing the gas valve refer to the troubleshooting guides in this chapter.

1.7.2 Improper Burner Functioning

With problems in this category, the burner ignites but exhibits abnormal characteristics such as "popping", incomplete lighting of burner, fluctuating flame intensity, and flames "rolling" out of the rethermalizer.

"Popping" indicates delayed ignition. In this condition, the main gas valve is opening but the burner is not immediately lighting. When ignition does take place, the excess gas "explodes" into flame, rather than smoothly igniting.

The primary causes of popping are:

- Incorrect or fluctuating gas pressure
- Misdirected or weak pilot flame
- Clogged burner flame-transfer holes
- Clogged burner orifices
- Clogged burners
- Inadequate make-up air
- Heat damage to the controller or ignition module
- An out-of-adjustment ignitor or broken ignition wire
- A defective ignition module

FGP55 SERIES GAS RETHERMALIZERS

CHAPTER 1: SERVICE PROCEDURES

1.7.2 Improper Burner Functioning (cont.)

If popping occurs only during peak operating hours, the problem may be incorrect or fluctuating gas pressure. Verify that the incoming gas pressure (pressure to the gas valve) is in accordance with the appropriate CE or Non-CE requirements listed in the Installation and Operation manual that came with the rethermalizer, and that the pressure remains constant throughout all hours of usage. Refer to **Adjusting Burner Manifold Pressure** in Section 1.4 if burner manifold pressure is suspected of being incorrect.

If popping is consistent during all hours of operation, verify that the pilot is properly positioned above the burner orifice and that the pilot pressure is correct. Correct pilot pressure is indicated by a flame 1 to 1½" long. Also verify that ignitor is properly adjusted (electrode tip 1/8" from pilot hood corner). Refer to Section 1.5 for pilot adjustment procedure.

Clogged burners, burner orifices and/or burner flame transfer holes (see Section 1.6.7, page 1-17 for reference) are also likely causes of delayed ignition. Clogged burners are indicated by uneven flame or partial flame on the burner face. Clogged orifices are indicated by no flame. Clogged burner flame transfer holes prevent the outermost burners from lighting immediately with the middle burners.

Another cause of popping is an insufficient air supply or drafts that are blowing the pilot flame away from the burner. Check for "negative pressure" conditions in the kitchen area. If air is flowing into the kitchen area, this indicates that more air is being exhausted than is being replenished and the burners may be starved for air.

If the rethermalizers gas and air supplies are okay, the problem most likely is with one of the electrical components. Examine the ignition module for signs of melting/distortion and/or discoloration due to excessive heat build-up in the rethermalizer. (This condition usually indicates improper flue performance.). Also, examine the controller for the same conditions. A melted or distorted ignition module is automatically suspect and should be replaced, but unless the condition causing excessive heat in the rethermalizer is corrected, the problem is likely to recur.

Next, ensure the ignition wire is tightly connected at both ends and examine it for obvious signs of damage. Again, if damage is due to excessive heat in the rethermalizer, that problem must also be corrected.

Check for proper operation by disconnecting the wire from the ignitor, inserting the tip of a screwdriver into the terminal, and holding it near the frame of the rethermalizer as the power switch is placed in the "ON" position. A strong, blue spark should be generated for at least 60 seconds.

 **DANGER**

MAKE SURE YOU ARE HOLDING THE INSULATED HANDLE OF THE SCREWDRIVER AND NOT THE BLADE. THE SPARKING CHARGE IS APPROXIMATELY 25,000 VOLTS.

Ensure the gap setting of the ignitor is correct (electrode tip 1/8" from pilot hood corner).

FGP55 SERIES GAS RETHERMALIZERS

CHAPTER 1: SERVICE PROCEDURES

Burners lighting on the left side only may be caused by a trailing pilot problem or improper burner manifold pressure.

Fluctuating flame intensity is normally caused by either improper or fluctuating incoming gas pressure, but may also be the result of variations in the kitchen atmosphere. Verify incoming gas pressure in the same way as for "popping", discussed in the preceding paragraphs. Variations in the kitchen atmosphere are usually caused by air conditioning and/or ventilation systems starting and stopping during the day. As air conditioning/ventilation systems start and stop, the pressure in the kitchen may change from positive or neutral to negative, or vice versa. Changes in airflow patterns may affect flame intensity.

Flames "rolling" out of the rethermalizer are usually an indication of negative pressure in the kitchen. Air is being sucked out of the rethermalizer enclosure and the flames are literally following the air. If negative pressure is not the cause, check for high burner-manifold gas pressure in accordance with the procedures in Section 1.4. An obstructed flue, which prevents the rethermalizer from properly exhausting, may also be the cause.

Excessively noisy burners, especially with *flames visible above the flue opening*, may indicate that the burner gas pressure is too high, the tube diffusers are defective or burned out, or it may simply be that the gas valve vent-tube is blocked (if applicable). If the gas pressure is correct, the tube diffusers are intact and in good condition, and the vent-tube is unobstructed (if applicable), the gas valve regulator is probably defective.

1.7.3 Improper Temperature Control

Temperature control is a function of several interrelated components, each of which must operate correctly. The principal component is the temperature probe. Depending upon the specific configuration of the rethermalizer, other components may include the computer itself, the temperature probe, and the ignition module.

Improper temperature control problems can be failure to control at setpoint.

Failure to Control at Setpoint

The problem may be with the temperature probe or the computer. Refer to the troubleshooting guides in this chapter.

FGP55 SERIES GAS RETHERMALIZERS

CHAPTER 1: SERVICE PROCEDURES



1.7.4 Computer-Related Problems

Common Computer Complaints

Most problems concerning computers have to do with programming them. There are four common complaints. The complaints, their causes, and corrective actions are:

1. Rethermalizer constantly displays "**HI**".

Cause: Setpoint incorrect or missing.

Corrective Action: Press  1 6 5 0, enter the correct setpoint using keypad, then press  to lock in the setpoint.

2. Temperature is displayed in Celsius.

Cause: Computer is programmed to display in Celsius.

Corrective Action: Press  1 6 5 8.

3. Temperature is constantly displayed.

Cause: Computer is programmed for constant temperature display.

Corrective Action: Press  1 6 5 L.

FGP55 SERIES GAS RETHERMALIZERS CHAPTER 1: SERVICE PROCEDURES

1.7.5 Leakage

Cookpot leaks are almost always due to improperly sealed high-limit, temperature probe, float switches and drain fittings. When installed or replaced, each of these components must be sealed with Loctite PST567 sealant or equivalent to prevent leakage. In very rare cases, a leak may develop along one of the welded edges of the cookpot, or where the tube is welded to the cookpot. When this occurs, the cookpot must be repaired or replaced.

If the sides or ends of the cookpot are coated with water minerals, the most likely cause is spillage over the top of the cookpot rather than leakage.

Cookpot locations (indicated by arrows) where potential leaks could occur.

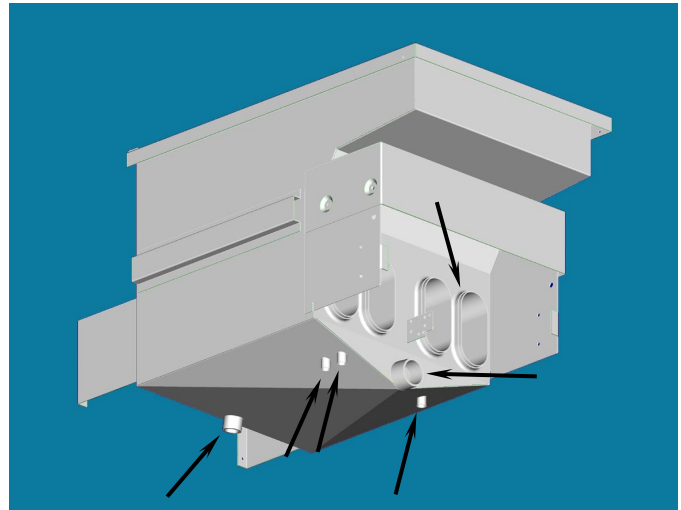

**FGP55 SERIES GAS RETHERMALIZERS
CHAPTER 1: SERVICE PROCEDURES**

1.8 Troubleshooting Guides

The following troubleshooting guides are intended to assist service technicians in quickly isolating the probable causes of equipment malfunctions by following a logical, step-by-step process.

1.8.1 General Troubleshooting

PROBLEM	PROBABLE CAUSES	CORRECTIVE ACTION
No display on computer.	A. Computer not turned on.	A. Press the ON/OFF switch to turn the computer on.
	B. No power to rethermalizer.	B. Verify that the rethermalizer is plugged in and that the circuit breaker is not tripped.
	C. Failed computer.	C. If available, substitute a computer known to be working for the suspect computer. If the rethermalizer functions correctly, order replacement from FASC.
The computer is illuminated, but there is no output to gas valve.	A. Float switch circuit is open.	A. Ensure float switch circuit is fully closed and is functioning. Make sure float is moving freely up and down and does not have a starch build up and that the shaft is not bent. Replace float switch if defective.
	B. Failed computer.	B. Replace the computer.
	C. Temperature probe defective.	C. Check temperature probe against standard Minco probe resistance chart. If found defective replace temperature probe. Also make sure that there is enough mineral content in the water to conduct resistance. See <i>Pr ob</i> corrective action below.
	D. Gas valve is suspect.	D. Go to "No burner flame" section.
<i>Pr ob</i> is displayed.	A. Indicates a problem with the computer temperature probe circuit.	A. Check to make sure probe resistance is correct. Also if water is too pure (low in minerals) the probes have trouble sensing resistance. Add ¼ cup of baking soda to the water. If the problem persists add additional baking soda to the water up to ½ cup. Baking soda is preferred since salt has a detrimental effect on rethermalizers. If probe is found defective replace.

**FGP55 SERIES GAS RETHERMALIZERS
CHAPTER 1: SERVICE PROCEDURES**

1.8.1 General Troubleshooting (cont.)

PROBLEM	PROBABLE CAUSES	CORRECTIVE ACTION
Display shows <i>HELP</i>. Heating indicator is on, but burners will not light.	A. Float switch stuck or defective.	A. Press the ON/OFF switch off. Clean float switch and make sure that the float switch is not bent and that the float moves freely up and down. Then press the ON/OFF switch on. Replace if found to be found defective.
	B. Gas valve is not turned on.	B. Turn the gas valve knob to the ON position.
	C. Manual gas shut off valve closed.	C. Verify that any in-line manual shut off valve is open. Verify that gas main cut off valve is open.
Display shows <i>HELP</i>, but rethermalizer operates normally (false alarm).	A. Failed computer.	A. If available, substitute a computer known to be working for the suspect computer. If the rethermalizer functions correctly, order replacement from FASC.
Display shows <i>Lo</i>, heating indicator cycles on and off normally, but burners will not light.	A. Failed computer.	A. If available, substitute a computer known to be working for the suspect computer. If the rethermalizer functions correctly, order replacement from FASC.
Display shows <i>Lo</i>, and the rethermalizer appears to operate normally.	A. Defective probe.	A. Check temperature probe against standard Minco probe resistance chart. If found defective replace temperature probe. Also make sure that there is enough mineral content in the water to conduct resistance. See Pr ob corrective action on the preceding page.
Display shows <i>Hl</i> and the rethermalizer appears to operate normally.	A. Defective probe.	A. Check temperature probe against standard Minco probe resistance chart. If found defective replace temperature probe. Also make sure that there is enough mineral content in the water to conduct resistance. See Pr ob corrective action on the preceding page.
	B. Failed computer.	B. If available, substitute a computer known to be working for the suspect computer. If the rethermalizer functions correctly, order replacement from FASC.

**FGP55 SERIES GAS RETHERMALIZERS
CHAPTER 1: SERVICE PROCEDURES**

1.8.1 General Troubleshooting (cont.)

PROBLEM	PROBABLE CAUSES	CORRECTIVE ACTION
Unit won't fill with water.	A. Water solenoid defective.	A. Replace the defective solenoid valve.
	B. Float switch stuck or defective.	B. Press the ON/OFF switch off. Clean float switch and make sure that the float switch is not bent and that the float moves freely up and down. Then press the ON/OFF switch on. Replace if found to be found defective. Toggle on the solenoid valve bypass switch to bypass the upper float switch and allow the unit to fill with water.
	C. Water supply turned off.	C. Check water supply valve. Use bypass switch to fill.
No burner flame.	A. Pilot does not stay lit.	A. Check high-limit switch. Switch continuity should be "0". If not, high-limit switch is defective. Replace high-limit switch. Flame sensor possibly out of alignment. Realign flame sensor. Check flame sensor for loose wires.
	B. Pilot stays lit, and the high-limit and flame sensor is working, but burners fail to light.	C. Inspect gas valve and replace if defective.
	D. Gas valve is known to be good, but there is not 24 VAC at the gas valve terminals.	D. Inspect temperature probe sensor (while still in cookpot) for damage. Replace if bent, dented or cracked. Inspect leads for fraying, burning, breaks and/or kinks. If found, remove and replace temperature probe.
	E. Continuity from ignition module block to gas valve is not "0".	E. Inspect wiring for breaks or shorts and repair if necessary.
Fluctuating or erratic lighting of burner flame.	A. Incoming gas supply pressures are not within range [Natural- 6-14" W.C. (1.49-3.49 kPa); Propane- 11-14" W.C. (2.74-3.49 kPa)]	A. Inspect gas supply to rethermalizer. Repair and/or replace faulty components (defective supply shut-off valves, incorrect piping size, etc.)
	B. Air in gas supply lines (new installation).	B. Allow unit to cycle on and off for approximately 30 minutes to force air from gas manifold and lines.

**FGP55 SERIES GAS RETHERMALIZERS
CHAPTER 1: SERVICE PROCEDURES**

1.9 Probe resistance Chart

Probe Resistance Chart														
<i>For use with rethermalizers manufactured with Minco Thermistor probes only.</i>														
F	OHMS	C	F	OHMS	C	F	OHMS	C	F	OHMS	C	F	OHMS	C
60	1059	16	130	1204	54	200	1350	93	270	1493	132	340	1634	171
65	1070	18	135	1216	57	205	1361	96	275	1503	135	345	1644	174
70	1080	21	140	1226	60	210	1371	99	280	1514	138	350	1654	177
75	1091	24	145	1237	63	215	1381	102	285	1524	141	355	1664	179
80	1101	27	150	1247	66	220	1391	104	290	1534	143	360	1674	182
85	1112	29	155	1258	68	225	1402	107	295	1544	146	365	1684	185
90	1122	32	160	1268	71	230	1412	110	300	1554	149	370	1694	188
95	1133	35	165	1278	74	235	1422	113	305	1564	152	375	1704	191
100	1143	38	170	1289	77	240	1432	116	310	1574	154	380	1714	193
105	1154	41	175	1299	79	245	1442	118	315	1584	157	385	1724	196
110	1164	43	180	1309	82	250	1453	121	320	1594	160	390	1734	199
115	1174	46	185	1320	85	255	1463	124	325	1604	163	395	1744	202
120	1185	49	190	1330	88	260	1473	127	330	1614	166	400	1754	204
125	1195	52	195	1340	91	265	1483	129	335	1624	168	405	1764	207

FGP55 SERIES GAS RETHERMALIZERS

CHAPTER 1: SERVICE PROCEDURES

1.10 Wiring Diagrams

Note: The diagrams in this section depict wiring as of the date of manual publication. It may not reflect design changes made to the equipment after publication. Refer to the wiring diagram affixed to the unit when actually troubleshooting this equipment.

1.10.1 Wiring Diagram FGP155 w/ Electronic Standing Pilot w/out Interface Board 120V

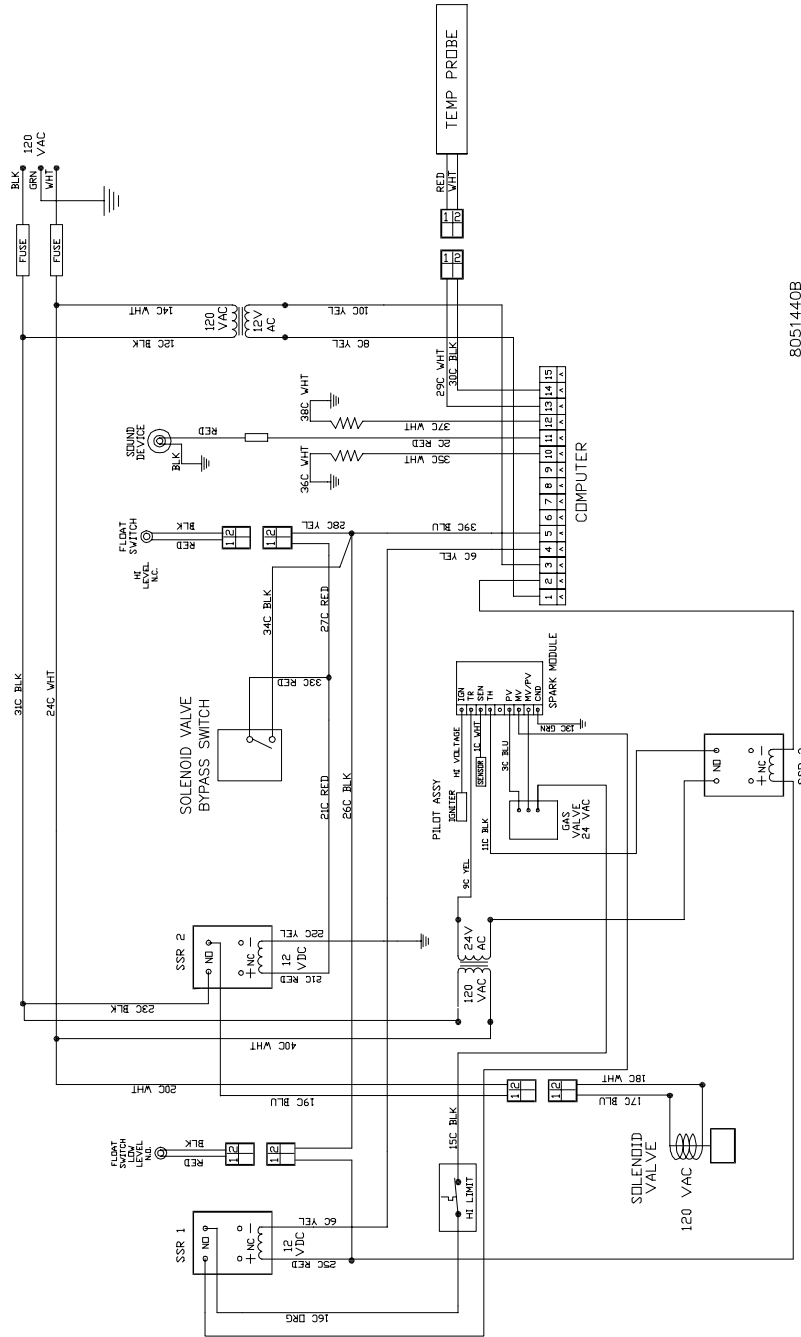

8051440B

FGP55 SERIES GAS RETHERMALIZERS CHAPTER 1: SERVICE PROCEDURES

1.10.2 Wiring Diagram FGP255 w/ Electronic Standing Pilot w/out Interface Board 120V

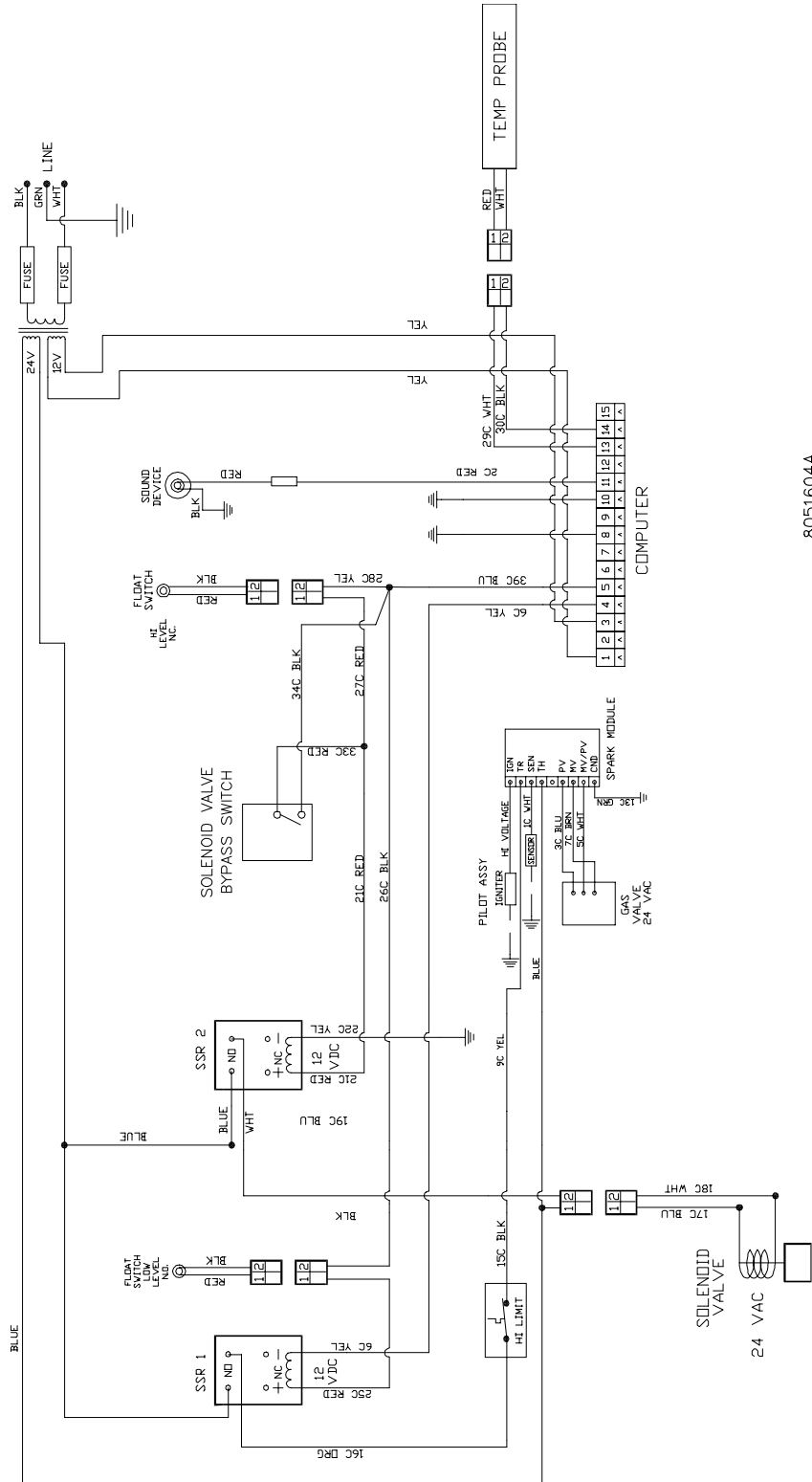

8051604A

FGP55 SERIES GAS RETHERMALIZERS CHAPTER 1: SERVICE PROCEDURES

1.10.3 Wiring Diagram/ Without Interface Board (Without Electronic Ignition)

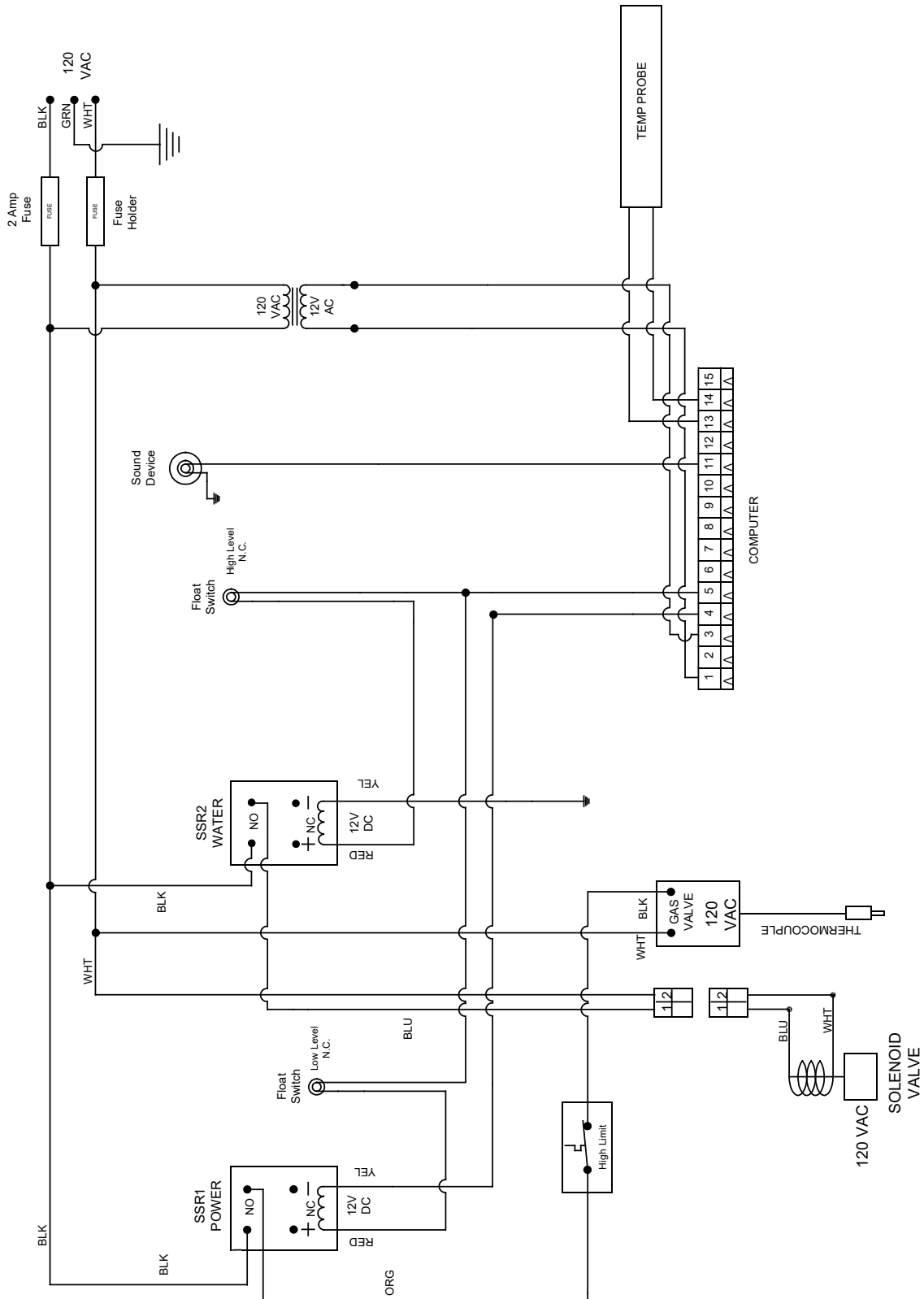

FGP55 SERIES GAS RETHERMALIZERS CHAPTER 1: SERVICE PROCEDURES

1.10.4 FGP55 Wiring Diagram with Water Board (Old Style) Simplified

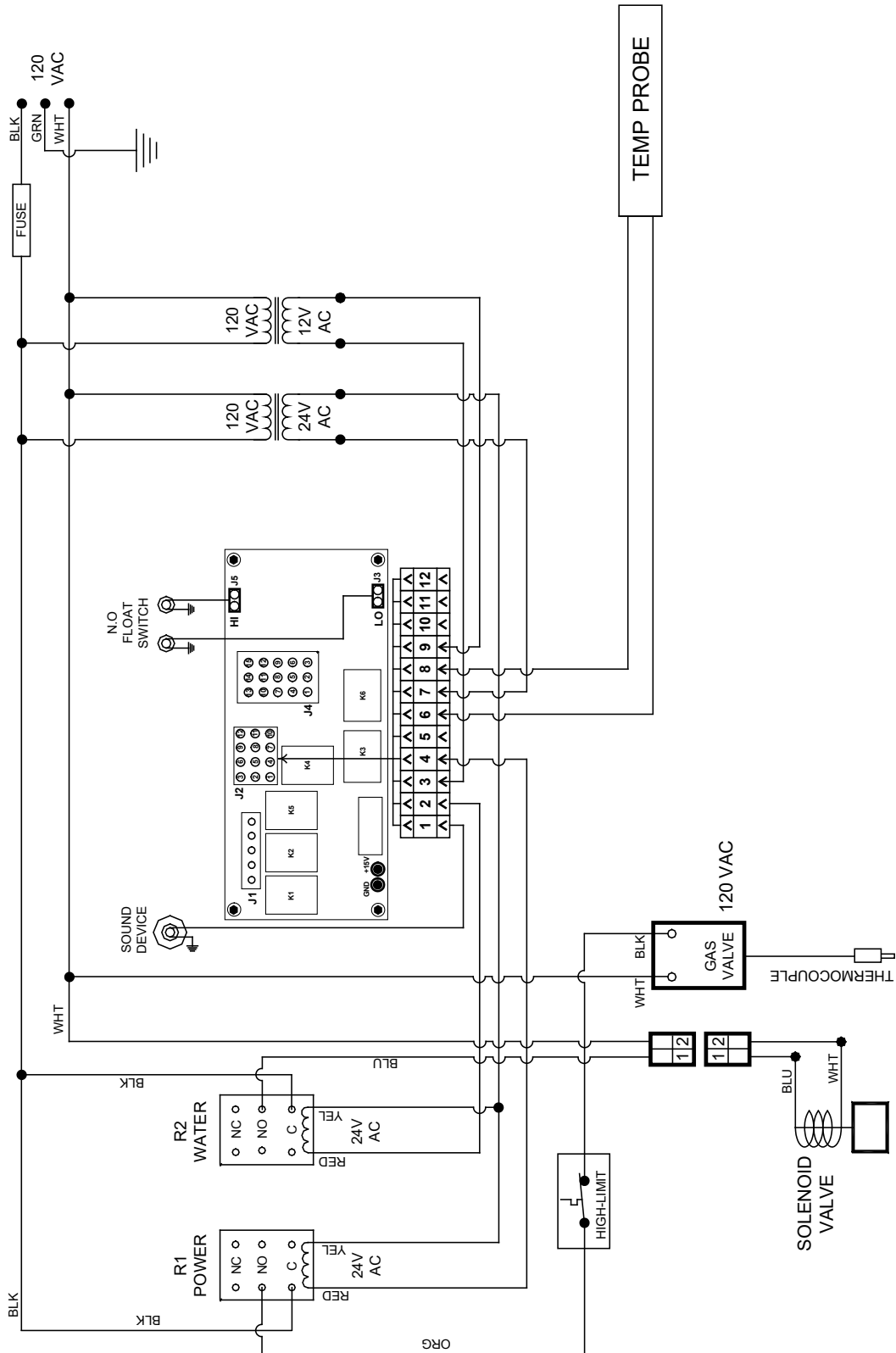

**FGP55 SERIES RETHERMALIZERS
CHAPTER 2: PARTS LIST**

2.1 FGP55 Primary Components (cont.)

ITEM	PART #	COMPONENT
1	823-3817SP	Cookpot- W/A- FGP55
2	810-2034	Manifold, Gas
3	810-2048	Orifice, Natural Gas (G20/25) #39 (2.53 mm)
	810-2060	Orifice, Natural Gas (G20/25) #42 (2.40 mm)
	810-2059	Orifice, LP Gas (G30/31) #53 (1.51 mm)
	810-2297	Orifice, MFG Gas #13 (4.70 mm)
4	106-1839SP	Pilot Burner Assembly- Natural (G20/25) Gas
	106-1128SP	Pilot Burner Assembly- LP (G30/31) Gas
*	810-0705	Tube, Pilot Gas Supply- ¼ x 23"
*	810-0703	Tube, Pilot Gas Supply- ¼ x 17½ "
*	106-3553SP	Cable, Ignition with Rajah Connector
*	807-1310	Flame Sensor
5	200-3618	Bracket, Manifold Support Right 10.88"
	200-3619	Bracket, Manifold Support Left 12.35"
6	210-8387	Diffuser
7	200-3614	Burner Mounting Bracket
8	810-2151	Burner, Left Side - Cast Iron
9	810-2149	Burner, Center - Cast Iron
	810-2785	Burner, Universal - Stamped Steel
10	810-2150	Burner, Right Side – Cast Iron
11	823-3248	Leg Support Assembly
12	807-3552	Gas Valve, Natural Gas, Electronic Ignition 24 VAC
	807-3628	Gas Valve, LP Gas, Electronic Ignition 24 VAC
	810-2156	Gas Valve, Natural Gas 120 VAC
	810-2323	Gas Valve, LP Gas 120 VAC
	807-2091	Gas Valve, G20/G25 Gas 24 VAC (CE ONLY)
	807-2127	Gas Valve, G31 Gas 24 VAC (CE ONLY)
13	210-3631	Channel, Front and Rear FGP155
	220-0320	Channel, Front and Rear FGP255
14	200-1675	Lower Hinge Bracket
15	211-3632	Side Panel, Left Side
16	212-3632	Side Panel, Right Side
*	200-3663	Magnet, Plate Door
17	106-2358	Wireway, Control Panel Assembly (<i>see Sec. 2.4 for components</i>)
18	210-3627	Bracket Hinge, Left
19	210-3640	Bracket Hinge, Right
20	824-1093	Top Cap- FGP155-after Aug. '02 (<i>use 824-1054 prior to 08/02</i>)
	824-1620	Top Cap- FGP255
*	230-1232	Joiner Strip FGP255
21	106-2355	Flue Assembly
22	210-3630	Flue Cap (<i>use 210-3625 for Flue Deflector</i>)
23	106-2346SP	Door Assembly
*	810-1422	Handle, Door – after April '02 (<i>use 810-2105 prior to 04/02</i>)
*	200-1301	Pin, Door
*	810-0066	Magnetic Catch, Door

* Not illustrated

**FGP55 SERIES RETHERMALIZERS
CHAPTER 2: PARTS LIST**

2.1 FGP55 Primary Components (cont.)

ITEM	PART #	COMPONENT
24	803-0325	Insert, Master Rack
25	803-0324	Master Rack 9 ¹ / ₈ " x 13.00"
26	106-2366SP	Cover Assembly, includes item 29
27	826-1117	Caster, 5-inch w/o Brake Kit – includes washers and screws
28	826-1118	Caster, 5-inch with Brake Kit – includes washers and screws
29	810-1374	Handle, FGP55 Cover
30	807-3593	Cord set, 10' Power
*	807-3548	Bushing, Strain Relief SR6N3-4
*	807-3545	Bushing, HEYCO SB-875-11 (7/8")
31	210-2804	Cover, Outlet Duct
32	200-3612	Back Panel, Rear Lower
32	200-3609	Back Panel, Rear Upper
33	806-5043	Leg

* Not illustrated

FGP55 SERIES RETHERMALIZERS

CHAPTER 2: PARTS LIST

2.2 Components and Controllers

Components are applicable to all FGP55 rethermalizers covered in this manual unless otherwise noted.

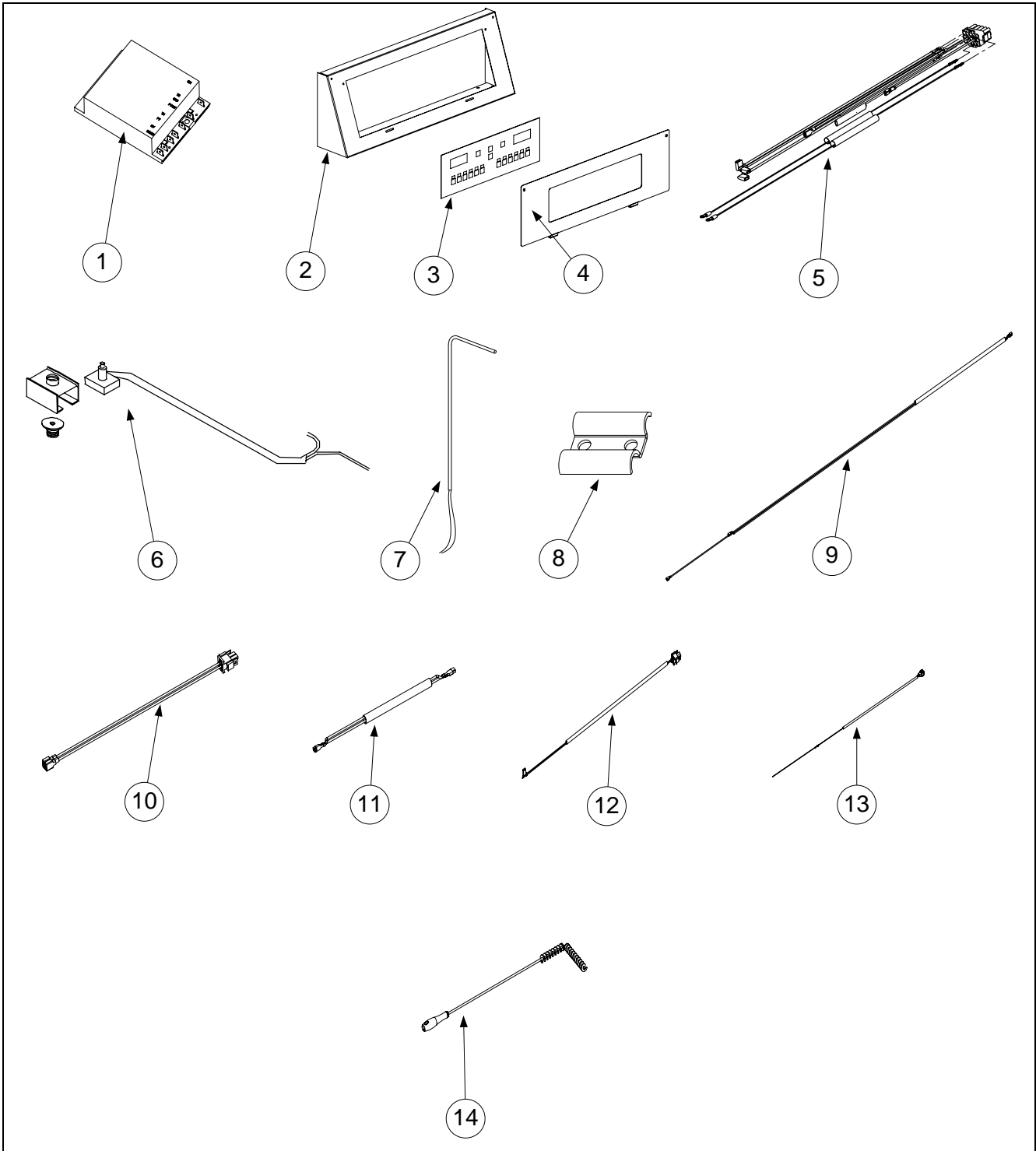

**FGP55 SERIES RETHERMALIZERS
CHAPTER 2: PARTS LIST**

2.2 Components and Controllers

ITEM	PART #	COMPONENT
1	826-2117	Spark Module (Domestic and CE)
*	106-3553SP	Cable, Ignition with Rajah Connector
2	210-3638	Panel, Control- Computer FGP55
3	106-3938	Computer, Assembly FGP55 includes item 4
4	823-3820	Bezel Assembly, Control Panel
5	106-2338	Harness, Computer Wire Assembly
6	106-1768SP	ECO Connector (Honeywell Valves Only- CE ONLY)
*	810-2398	ECO Connector (Robertshaw Valves Only- CE ONLY)
7	106-2361SP	Probe Assembly (RTD), Temperature, Dean Computer
*	106-0987	Harness, Wire-Temp Probe
*	809-0888	Clip, Tinnerman
*	810-2164	Spring, Space- Electronic Thermostat Probe
*	810-2046	Spring, Spacer- High Limit Capillary Bulb
8	210-4367	Clamp, Electronic Thermostat Probe
9	106-2351SP	Harness, Wiring Spark Module
10	106-2353	Harness, Relay Component Wire
11	106-2352	Harness, Transformer/Fuse Wire
12	106-2349	Harness, Low Level Float wire
13	106-2344	Harness, High Level Float Wire
14	803-0278	L-Brush

* Not illustrated

**FGP55 SERIES RETHERMALIZERS
CHAPTER 2: PARTS LIST**

2.3 Float Switch Assemblies

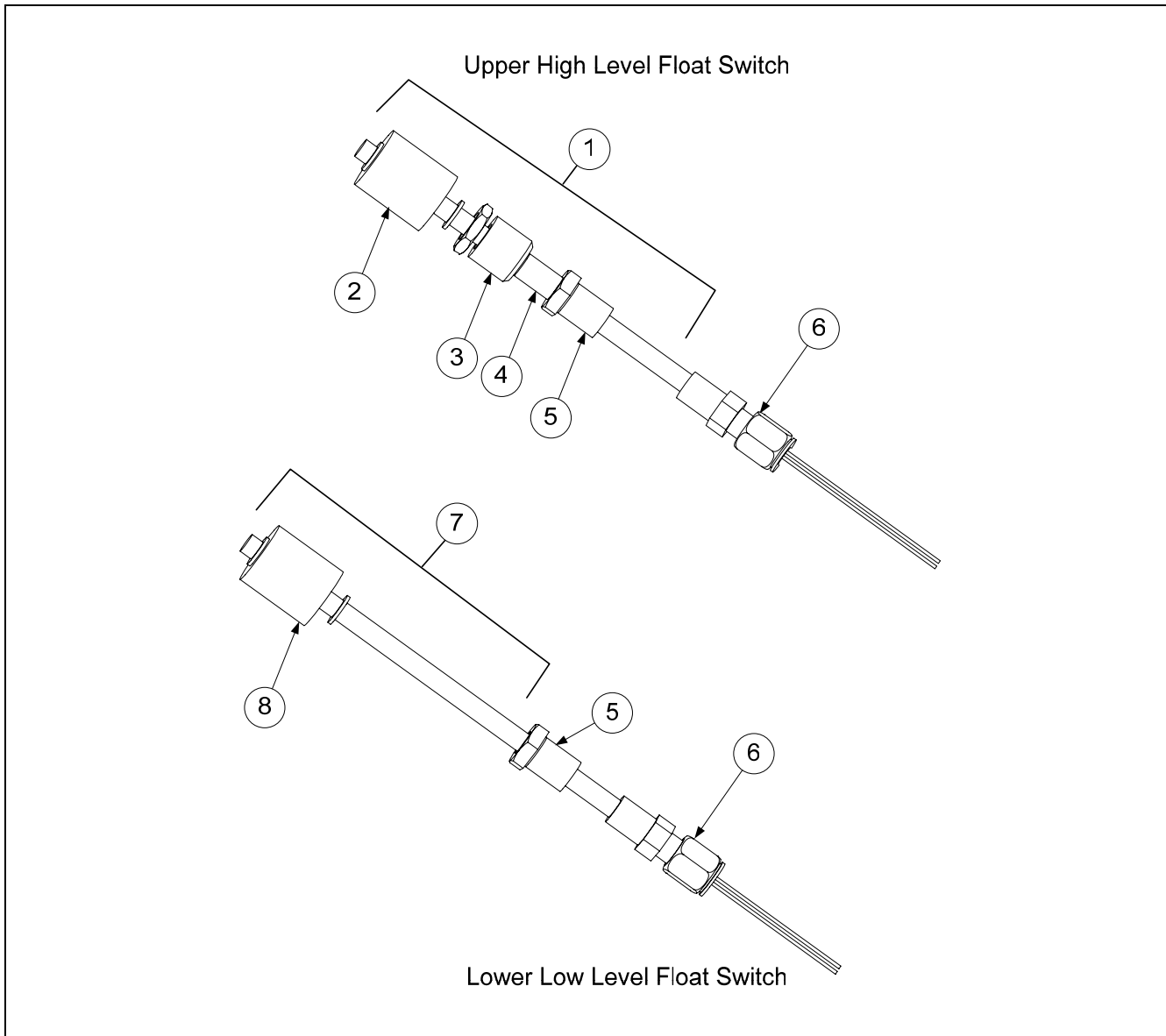

ITEM	PART #	COMPONENT
1	106-2345SP	Switch, Float – High Level Assembly
2	807-3793	Switch, High Level
3	813-0805	Coupling, 1/8-inch NPT SS
4	813-0806	Nipple, 1/8-inch NPT x 1 1/2 SS
5	813-0807	Bushing, 1/4-inch NPT x 1/8-inch NPT SS
6	813-0619	Flareless Male Tube Connection SS
7	826-2146	Switch, Float Kit – Low Level Assembly includes item #6
8	106-0960	Switch, Float N/O Low Level
*	210-3597	Cover, Front High Level Float Housing

* Not illustrated

**FGP55 SERIES RETHERMALIZERS
CHAPTER 2: PARTS LIST**

2.4 Control Boxes

2.4.1 Component and Spark Module Boxes without Waterboard

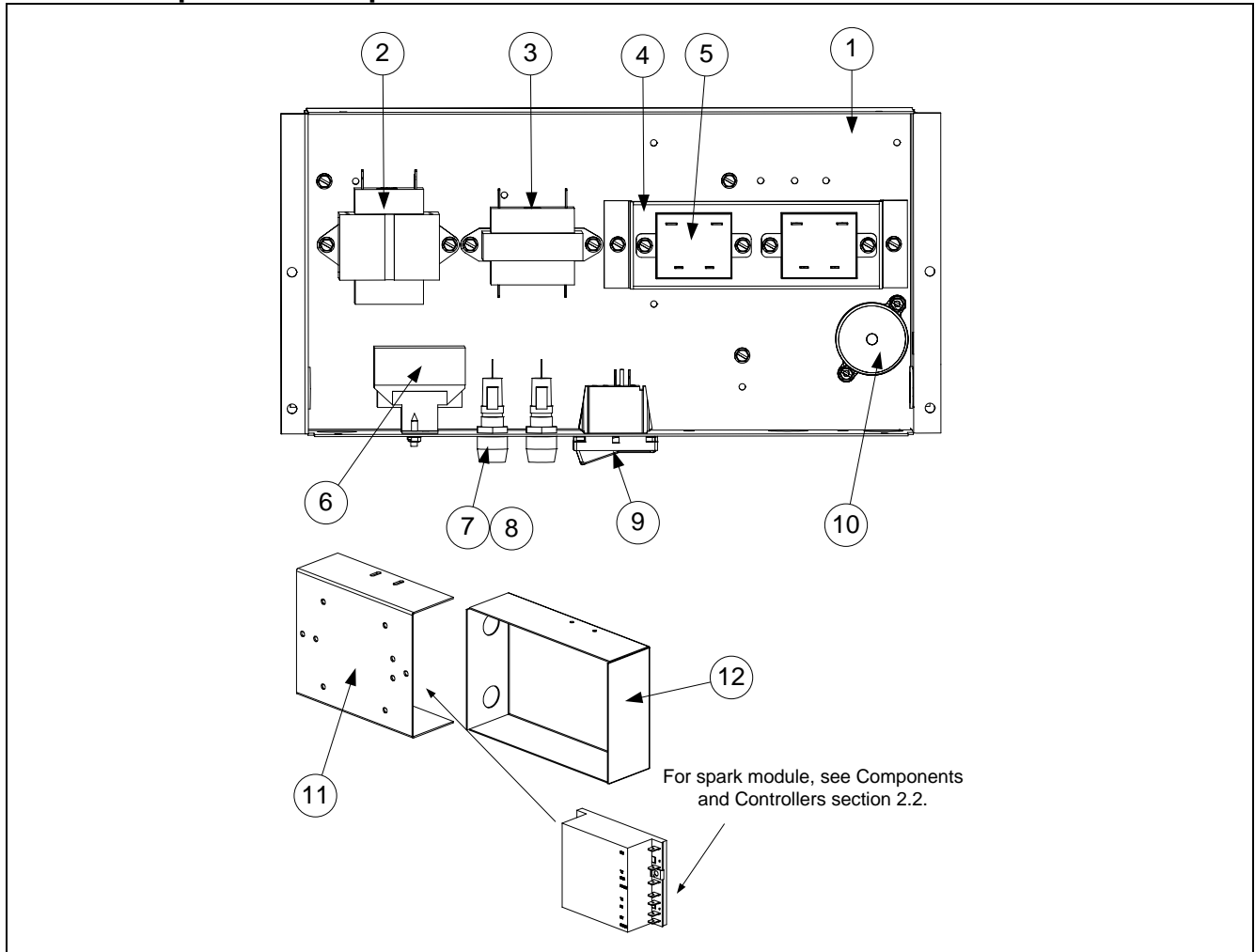

ITEM	PART #	COMPONENT
	106-2358	Wireway Assembly, Component RG55
1	824-0967	Wireway Weldment, FGP55 Control Panel
2	807-0800	Transformer, 120V 50/60HZ, 50VA 24VAC
3	807-0855	Transformer, 120V 50/60HZ, 20VA 12VAC
4	900-8715	Relay Bracket
5	826-1733	Relay, Solid State 18AMP
6	807-3799	High-Limit Thermostat- Manual Reset 250° F
7	807-1321	Holder, Fuse AGC Panel Mount ¼-inch
8	807-3592	Fuse, Slow Blow 2 AMP 250V
9	807-3580	Switch, SPST Rocker Black
10	806-7179SP	Sound Device
11	823-4005	Bracket, Spark Module W/A
12	200-3643	Cover, Spark Module

* Not illustrated

FGP55 SERIES RETHERMALIZERS CHAPTER 2: PARTS LIST

2.4.2 Spark Module Control Box with PCB Waterboard

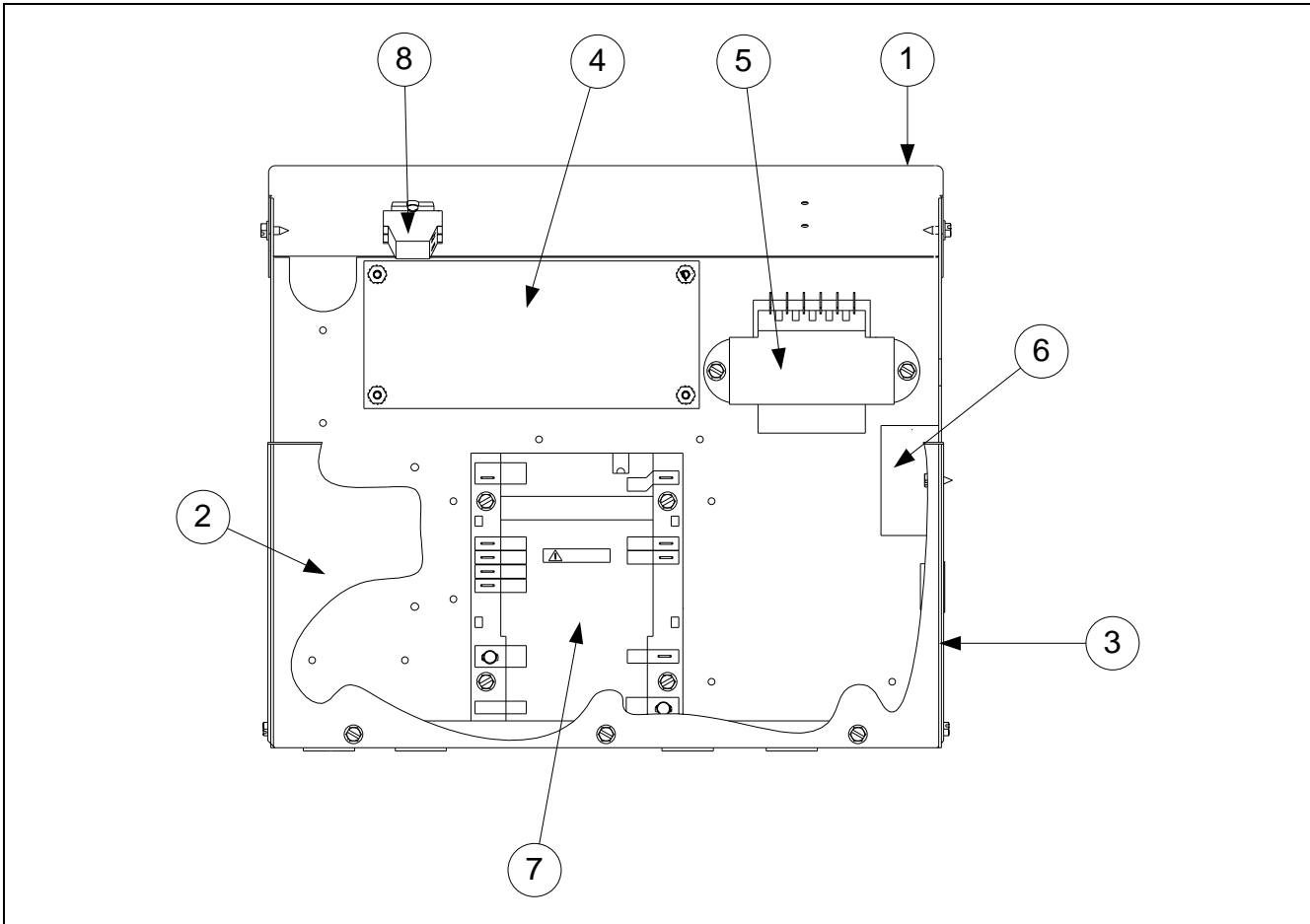

ITEM	PART #	COMPONENT
	806-9298	Control Box Assembly, Rethermalizer
1	900-5223	Cover, Control Box
2	900-8419	Front, Control Box CKE (<i>use 900-8325 for Boston Market</i>)
3	806-8007	Assembly, Component Box
4	806-9295	Controller PCB, Water Board (<i>used on older units</i>)
5	807-2176	Transformer, V/T Dual Voltage
6	806-4797	Buzzer Assembly
7	807-3366	Module, Honeywell Spark
*	106-3553SP	Cable, Ignition with Rajah Connector
*	807-3484	Connector, Rajah
*	106-0676SP	Ignition Cable 18"
8	810-1164	Block, Terminal
*	806-9286SP	Harness, 12-pin Wiring
*	WIR0366SP	Wire Assembly Contactor Box
*	807-1713	Sound Device, GSMS

* Not illustrated

**FGP55 SERIES RETHERMALIZERS
CHAPTER 2: PARTS LIST**

2.5 Incoming Water Plumbing

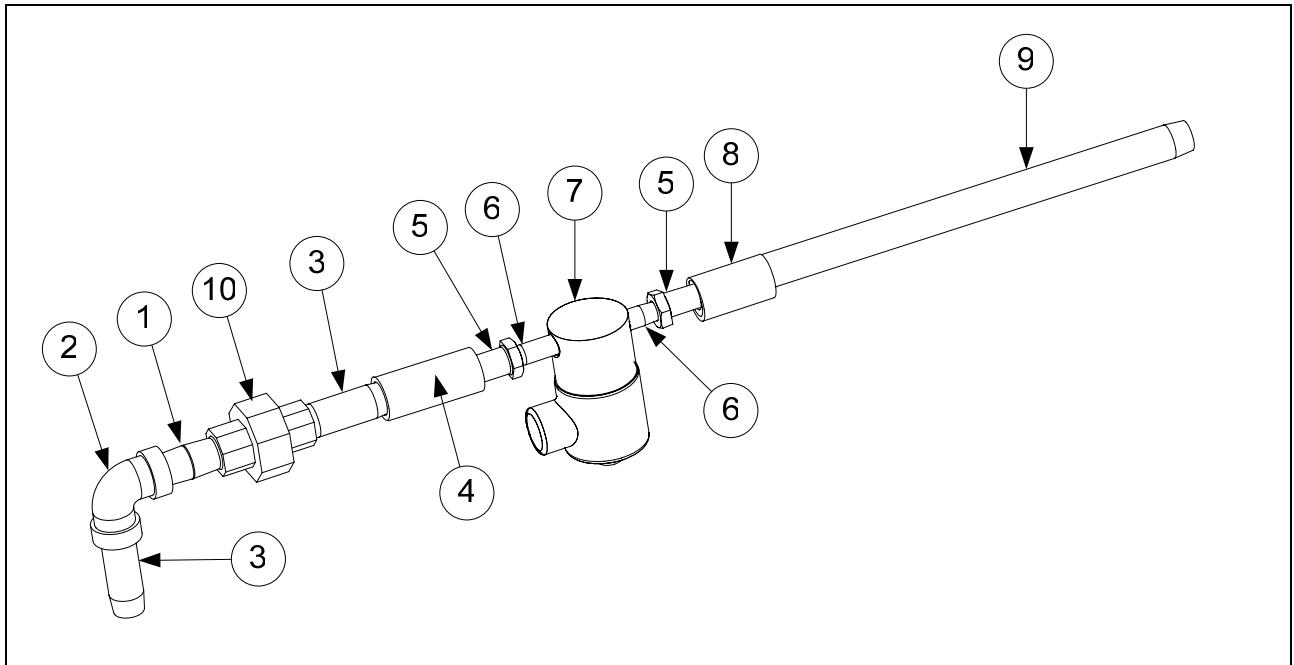

ITEM	PART #	COMPONENT
1	813-0772	Nipple, $\frac{3}{8}$ -inch x CLS SS
2	813-0773	Elbow, $\frac{3}{8}$ -inch x 90° SS
3	813-0815	Nipple, $\frac{3}{8}$ -inch x 2-inch SS
4	810-2419	Valve, Check $\frac{3}{8}$ -inch NPT
5	813-0807	Bushing, $\frac{1}{4}$ -inch NPT x $\frac{1}{8}$ -inch NPT SS
6	813-0806	Nipple, $\frac{1}{8}$ -inch NPT x 1½-inch SS
7	807-3635	Solenoid, 2-way $\frac{1}{4}$ -inch NPT 24/50
8	813-0462	Coupling, $\frac{3}{8}$ -inch NPT x 1.19 SS
9	813-0811	Nipple, $\frac{3}{8}$ -inch x 10¾-inch SS
10	813-0844	Union, $\frac{3}{8}$ -inch NPT SS

**FGP55 SERIES RETHERMALIZERS
CHAPTER 2: PARTS LIST**

2.6 Drain and Associated Parts

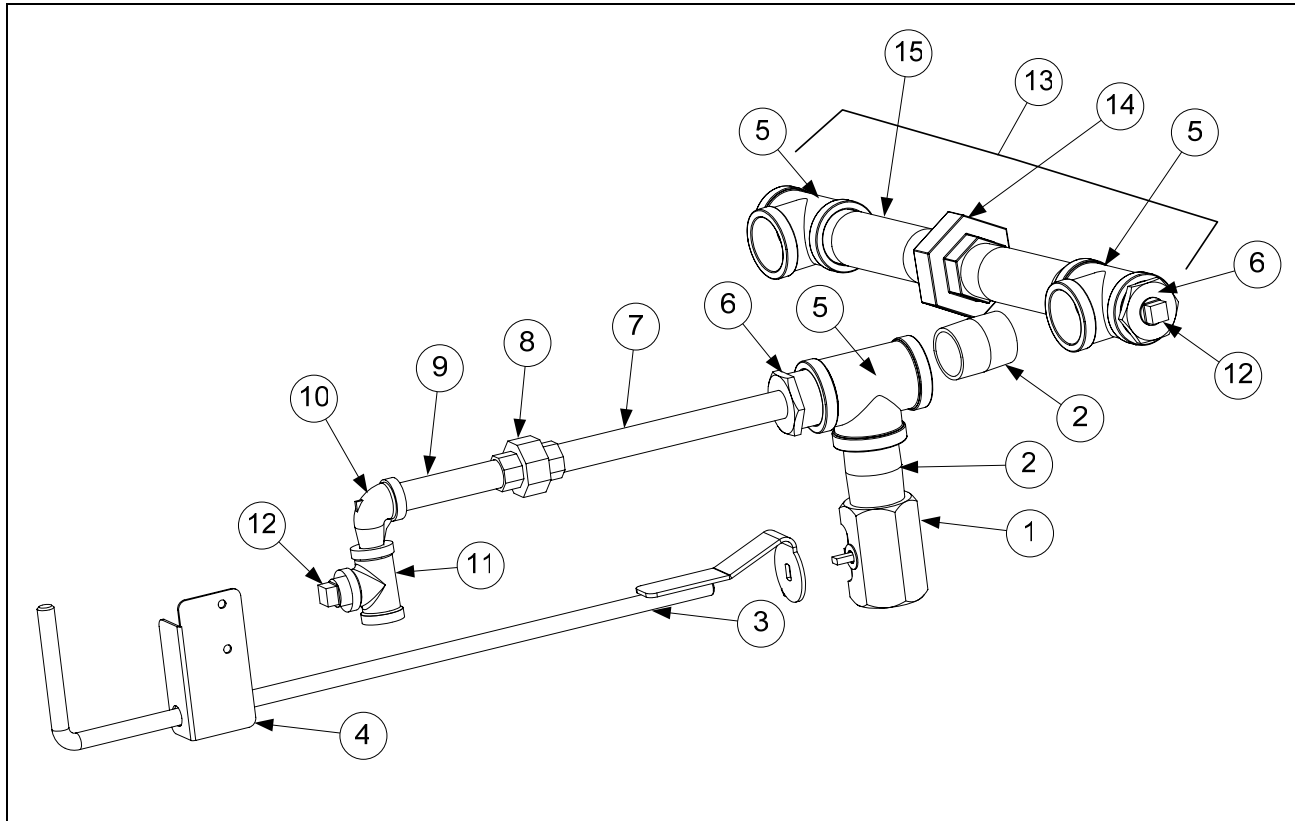

ITEM	PART #	COMPONENT
1	810-1825	Valve, 1¼-inch x 1¼-inch Drain SS
2	813-0801	Nipple, 1¼-inch NPT x CLS SS
3	823-5695	Handle, Drain Extension FGP55
*	816-0631	Sleeve, Drain Valve Handle - Red
4	210-3596	Bracket Handle Locator
5	813-0802	Tee, 1¼-inch SS
6	813-0814	Bushing, 1¼-inch x ½-inch Galv
7	813-0812	Nipple, ½-inch NPT x 9⅝-inch SS
8	813-0803	Union, ½-inch NPT SS
9	813-0804	Nipple, ½-inch NPT x 5-inch SS
10	813-0616	Elbow, ½-inch x 90° SS
11	810-2343	Tee, SS NPT ½-inch
12	813-0336	Plug, Pipe ½-inch NPT 150# SS
13	106-5639	Drain Manifold Assembly FGP255
14	813-0895	Union, 1¼-inch SS
15	813-0896	Nipple, 1¼-inch x 6.0-inch SS

* Not illustrated

**FGP55 SERIES RETHERMALIZERS
CHAPTER 2: PARTS LIST**

2.7 Gas Plumbing

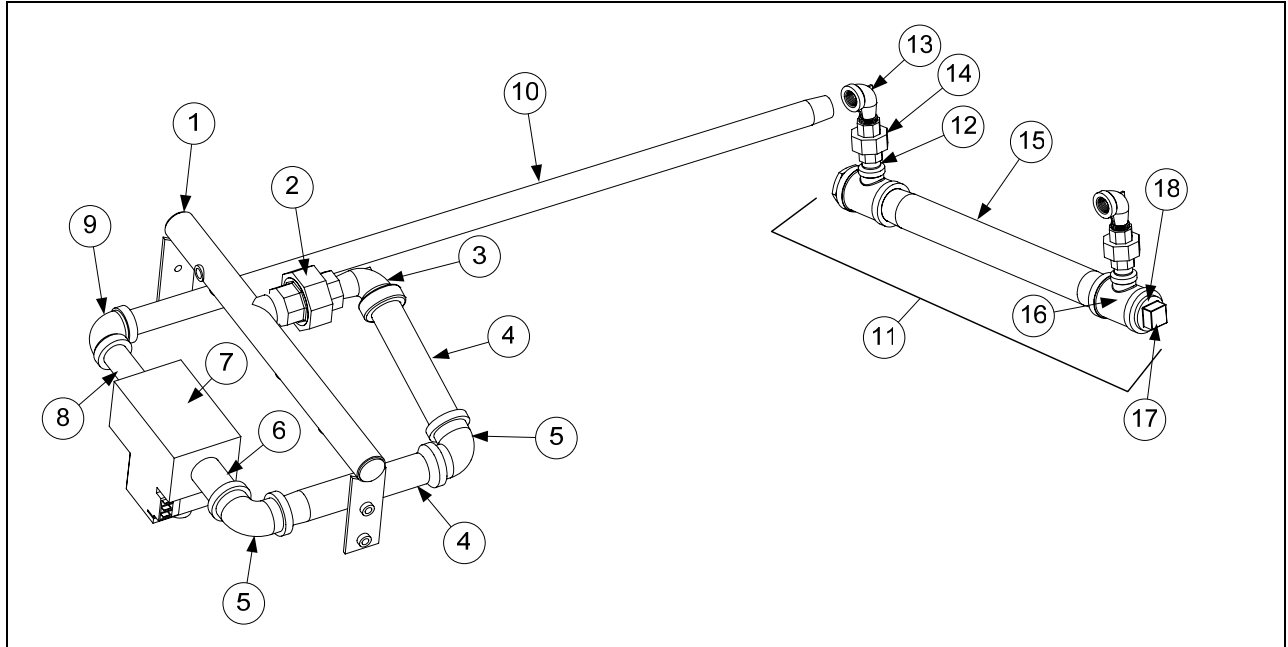

ITEM	PART #	COMPONENT
1	810-2034	Gas Manifold
2	813-0174	Union, 3/4-inch NPT 150# BM
3	813-0168	Elbow, Street 3/4-inch x 90° BM
4	813-0259	Nipple, 3/4-inch NPT x 6.00-inch BM
5	813-0066	Elbow, 3/4-inch x 90° BM
6	813-0254	Nipple, 3/4-inch NPT x 3.00-inch BM
7	-	Valve, Gas See item #12 on page 2-2
8	813-0247	Nipple, 1/2-inch NPT x 3.50-inch BM
9	813-0062	Elbow, 1/2-inch x 90° BM
10	813-0751	Nipple, 1/2-inch NPT x 27.00-inch BM
11	106-5640	Manifold Assembly, Rear Gas FGP255
12	813-0022	Nipple, 1/2-inch x Close NPT BM
13	813-0165	Elbow, Street 1/2-inch x 1/2-inch NPT 90° BM
14	813-0173	Union, 1/2-inch NPT BM
15	813-0484	Nipple, 1 1/4-inch NPT x 14.00-inch BM
16	813-0637	Tee, 1 1/4-inch x 1 1/4-inch x 1/2-inch BM
17	813-0658	Plug, 1 1/4-inch BM Sq. Head
18	813-0814	Bushing, 1 1/4-inch x 1/2-inch NPT Galv.

**FGP55 SERIES RETHERMALIZERS
CHAPTER 2: PARTS LIST**

2.8 Fasteners

ITEM	PART #	COMPONENT
*	809-0428	Bolt, ¼-inch – 20 x ½-inch Hex Head ZP Tap
*	809-0429	Bolt, ¼-inch – 20 x 2.00-inch Hex Head ZP Tap
*	809-0514	Capscrew, 5/16-inch-18 NC Hex
*	809-0448	Clip, Tinnerman
*	826-1366	Nut, 4-40 Keps Hex (Pkg. of 25) (809-0237)
*	826-1358	Nut, 6-32 Keps Hex (Pkg. of 25) (809-0049)
*	809-0247	Nut, 8-32 Keps Hex
*	826-1376	Nut, 10-32 Keps Hex (Pkg. of 10) (809-0256)
*	809-0766	Nut, 10-32 Keps Hex SS
*	809-0581	Nut, ½ NPT Locking
*	809-0020	Nut Cap 10-24 NP
*	826-1372	Nut Grip ¼-inch 1/4-20 Hex NP (Pkg. of 10) (809-0059)
*	809-0417	Nut Flange ¼-inch 1/4-20 Serr
*	809-0535	Nut, "T" ¼-inch-20 x 7/16 SS
*	826-1389	Nut, Nylock ¼-inch-20 (Pkg. of 10) (809-0803)
*	809-0540	Nut, Lock ½-inch-13 Hex 2-Way ZP
*	813-0154	Plug, Pipe ⅛-inch Brass, Hex Head
*	826-1359	Screw, 4-40 x ¾-inch Slotted Round Head (Pkg. of 25) (809-0354)
*	826-1365	Screw, 6-32 x ⅜-inch Slot Head (Pkg. of 25) (809-0095)
*	809-0357	Screw, 6 x ⅜-inch Phillips Head NP
*	809-0359	Screw, 8 x ¼-inch Hex Washer Head
*	809-0360	Screw, 8 x ⅜-inch Hex Washer Slot Head
*	826-1371	Screw, 8 x ½-inch Hex Head ZP (Pkg. of 25) (809-0361)
*	809-0818	Screw, 8 x ½-inch Type B
*	809-0364	Screw, 8 x ⅝-inch Hex Washer Head ZP
*	809-0518	Screw, 8-32 x ⅜-inch Hex Washer Slotted Head SS
*	809-0104	Screw, 8-32 x ½-inch Slotted Head ZP
*	826-1363	Screw, 8-32 x ½-inch NP (Pkg. of 25) (809-0103)
*	826-1360	Screw, 10-24 x 5/16-inch Round Slot Head ZP (Pkg. of 25) (809-0024)
*	826-1330	Screw, 10-32 x ⅜-inch Slot Head SS (809-0117)
*	809-1003	Screw, 10-32 x ⅜-inch Hex Trim Head SS
*	826-1375	Screw, 10-32 x ¾-inch Hex Trim Head SS (Pkg. of 5) (809-0401)
*	809-1000	Screw, 10-32 x 1¼-inch Hex Sck C/S
*	826-1374	Screw, 10 x ½-inch Hex Head (Pkg. of 25) (809-0412)
*	809-0266	Screw, 10 x ½-inch Phillips Head ZP
*	809-0434	Screw, 10 x ⅜-inch Hex Washer Head NP
*	809-0123	Screw, 10 x ¾-inch Slot Head
*	826-1389	Screw, 1/4-20 x ¾-inch Hex Head ZP (Pkg. of 10) (809-0131)
*	809-0582	Washer ½ NPT Locking
*	809-0184	Washer, #10 LK ZP
*	809-0190	Washer, .625 X .275 X 40 Flat SS
*	809-0191	Washer, Lock 1/4 Spring ZP
*	809-0193	Washer, Flat 1/4 Nylon
*	809-0194	Washer, Flat 5/16 ZP

Frymaster[®]

FRYMASTER
8700 LINE AVENUE, SHREVEPORT, LA 71106-6800

800-551-8633
318-865-1711
WWW.FRYMASTER.COM
EMAIL: FRYSERVICE@WELBILT.COM



Welbilt offers fully-integrated kitchen systems. Welbilt's portfolio of award-winning brands includes Cleveland™, Convotherm®, Crystal Tips®, Dean®, Delfield®, Fabristeel®, Frymaster®, Garland®, Inducs®, Koldtech®, Kolpak®, Lincoln®, McCann's™, Merco®, Merrychef®, Multiplex®, RDI®, SerVend™, SunFire®, U.S. Range™, and WMaxx™. Supported by service brands: FitKitchen®, kitchen systems; and KitchenConnect®, cloud-based open platform.

Bringing innovation to the table • welbilt.com

©2023 Frymaster LLC. except where explicitly stated otherwise. All rights reserved. Continuing product improvement may necessitate change of specifications without notice.

Part Number FRY_SP_8196250 09/2023