

# Accessories

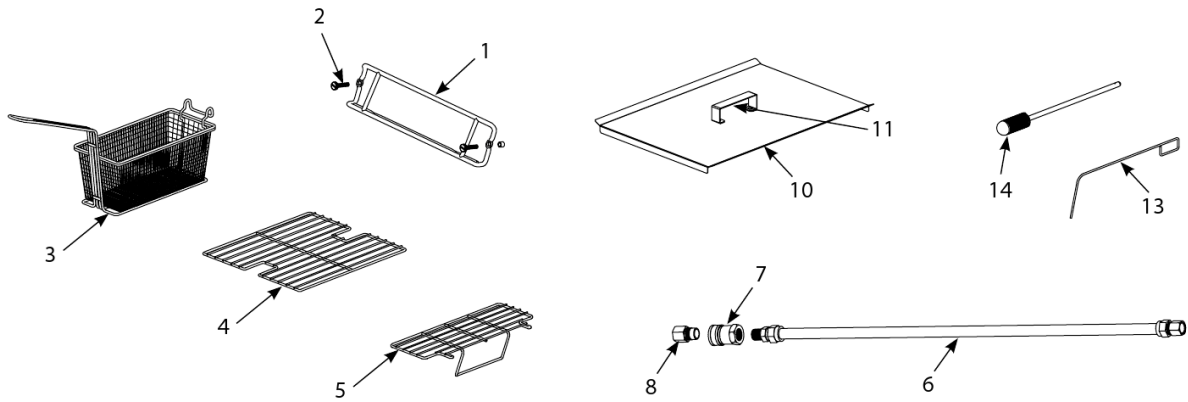

# Accessories

#	PART #	DESCRIPTION	QTY	Note
1	8102793	Hanger - Wireform Basket	1	
1a	1062186	Basket Hanger, Burger King®	1	
1b	8234447	Basket Hanger, Buffalo Wild Wings® and Jack in the Box®	1	
1c	8231462	Basket Hanger, Checkers®	1	
1d	1062185	Basket Hanger, Checkers®, Bracket	1	
2	8090171	Thumbscrew, 0.25-20 x 1.375-inch	1	
2a	8090921-FRY	Spacer, Basket Hanger	1	
2b	8030099	Basket, Full Size	1	
3	8030271	Basket, Twin Size	1	
3a	8030190	Basket, Twin, Buffalo Wild Wings®	1	
3b	8030357	Basket, Triple	1	
4	8030132	Rack, Full-Vat Basket Support	1	
5	8030133	Rack, Dual-Vat Basket Support	1	
5a	8030032	Basket Support Rack, J2X	1	
5b	8030136	Basket Support Screen, Full Vat	1	
5c	8030037	Basket rack, fine mesh GF14	1	
6	8100088	Gas Line, 1-Inch Dormont Flexible, 36-Inch	1	
6a	8100084	Hose, Flexible Gas, 0.75-inch x 48-inch	1	
7	8100073	Coupling, Gas Line Female Quick Disconnect 1-inch	1	
8	8100074	Quick-Disconnect Fitting, 1-Inch Male	1	
9	8030188	Sediment tray, GF14	1	
9a	8030103	Valve, Manual Gas Shut Off 0.75"	1	
9b	8030107	Sediment Trays (Full-Vat)	1	
9c	8030108	Sediment Trays (Left Dual-Vat)	1	
10	8065518	Cover, Frypot, Full Vat	1	
10a	8063232	Cover, Frypot, Dual Vat	1	
11	8260993SP	Handle Kit, Frypot Cover	1	
12	8261351	Nut Retainer, 0.25-20 Std. Fluecap	10	[1]
13	8030197	Fryer's Friend	1	
14	8030209	Brush, Frypot	1	
15	8030278	L-shaped Brush	1	
16	8233660	Crumb Scoop	1	
17	8235936	Splash Guard, Right	1	
18	8235937	Splash Guard, Left	1	
19	OPT32686	Foodwarmer	1	[2]
19a	8066988SP	Foodwarmer Kit	1	
20	1064786	Spreader Storage Pan	1	
21	9103557	Fryer's Friend 27"	1	[3]
22	8261017	Screw Kit, Flue Deflector	1	[3]
23	KIT3647	Applebee's® Heat Lamp	1	[4]

## PART NOTES:

- [1] - for use on standard fluecap
- [2] - with scoop pan
- [3] - See Section 2.6 for more information and associated items
- [4] - available as OPT33030 for MJ 45 only

# Basket Lift and Associated Parts

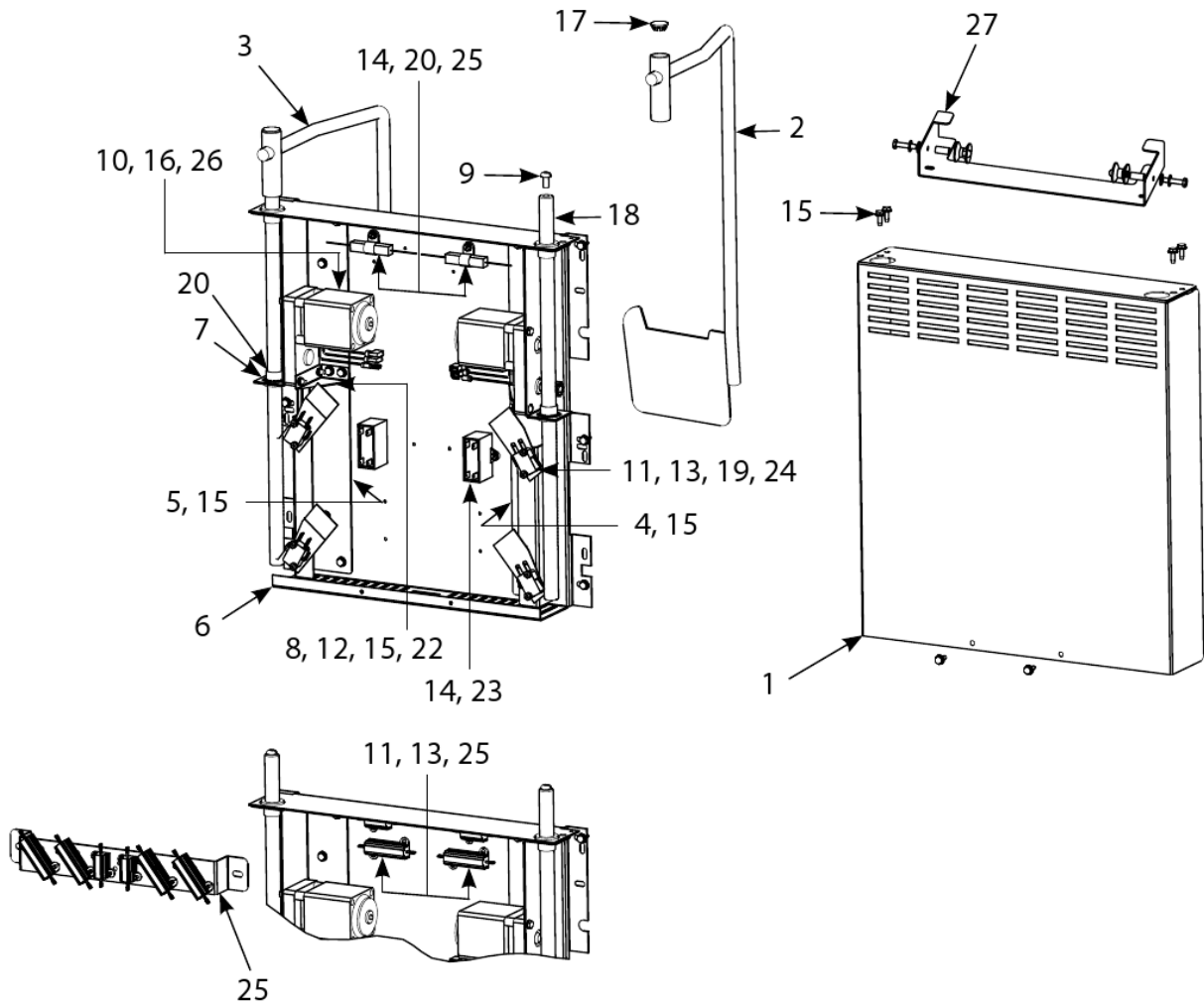

## RESOURCE NOTES:

Assemblies [1061807SP](#) (100-120V) and [1061810](#) (230/240/250V) do not include Items 1, 2, 3, 9, or 17. These items must be ordered separately.

For 100-120V units, each individual resistor ([8072661](#)) may be replaced or the entire resistor assembly ([8068530SP](#)) may be replaced.

For 208-250V units, the entire resistor assembly ([1062771](#) or [8069185](#)) must be replaced.

Wiring has been omitted for clarity.

## Basket Lift and Associated Parts

#	PART #	DESCRIPTION	QTY	Note
1	9104776	Cover, Modular Basket Lift Rear S/S	1	
1a	9004776	Cover, Modular Basket Lift Rear S/S	1	[1]
1b	8261991	Cover, Kit S/S Modular Basket Lift with screws	1	[2]
2	8237062	Basket Lift Arm, Left	1	
3	8237064	Basket Lift Arm, Right	1	
4	9018499	Chassis, Left Basket Lift	1	
5	9028499	Chassis, Right Basket Lift	1	
6	2002942	Mount, Modular Basket Lift	1	
7	8090082	Ring, Bushing Retainer	1	
8	8261361	Screw - #2-32 x 1" Slotted Truss Head	25	
9	8090127	Screw, 0.25-20 X 0.5-inch Slotted Round Head	1	
10	8090186	Lock Washer w/External Teeth, #8	1	
11	8261366	Nut - #4-40 Keps Hex	25	
12	8090247	Nut - #8-32 Keps Hex	1	
13	8261359	Screw - #4-40 x 0.75" Slotted Round Head	25	
14	8261371	Screw - #8 x 0.5" Hex Head ZP	25	
15	8261374	Screw - #10 x 0.5" Hex Head	25	
16	8090503	Screw - #8-32 x 0.5" Slotted Truss Head	1	
17	8100172	Plug, 0.625-inch Stainless Steel Hole	1	
18	8101012	Rod, Basket Lift	1	
19	8120442	Insulation, Microswitch	1	
20	8130035	Bushing , Oiltite .640 I.D.	1	
21	8160033	Tie Wrap, Screw Mount	1	
22	9005529	Gusset, Basket Lift Motor	1	
23	8072513	Capacitor - 12.5 MFD/330VAC	1	
24	8072572	Microswitch	1	
25	8068530SP	Resistor Assy, 100-120V Modular Basket Lift	1	
25a	1062771	Resistor Assembly, CE, 208-250V Modular Basket Lift	1	
26	8065964SP	Motor Assembly - 208-240V	1	
26a	8101013	Gear, Modular Basket Lift	1	
26b	8090504	Set Screw, 6-32 x .185	1	
26c	8100973	Woodruff Key - Gearmotor Assembly	1	
27	8069257SP	Roller Assembly, Basket Lift	1	
28	1061807SP	Basket Lift Assemblies, 100-120V w/o Relay	1	[3]
28a	1061810SP	Basket Lift Assemblies, 202-250V w/o Relay	1	
28b	KIT6421	Basket Lift Assemblies, Complete 120V Basket Lift Assembly for FPP35/45	1	
28c	KIT7193	Basket Lift Assemblies, Complete 230V Basket Lift Assembly for FPP35/45	1	
28d	KIT7413	Basket Lift Assemblies, Complete 230V Basket Lift Assembly for PMJ35	1	
29	8073699	Basket Lift Power, Non-CE/CE68"	1	
30	8241476	Tray, Drip Left	1	
31	8241477	Tray, Drip Right	1	
32	2008862	Drip Plate/Shield	1	

# Basket Lift and Associated Parts

#	PART #	DESCRIPTION	QTY	Note
---	--------	-------------	-----	------

**PART NOTES:**

- [1] - CRS cover
- [2] - with 12 screws
- [3] - without relay

# Casters, Legs, and Associated Hardware

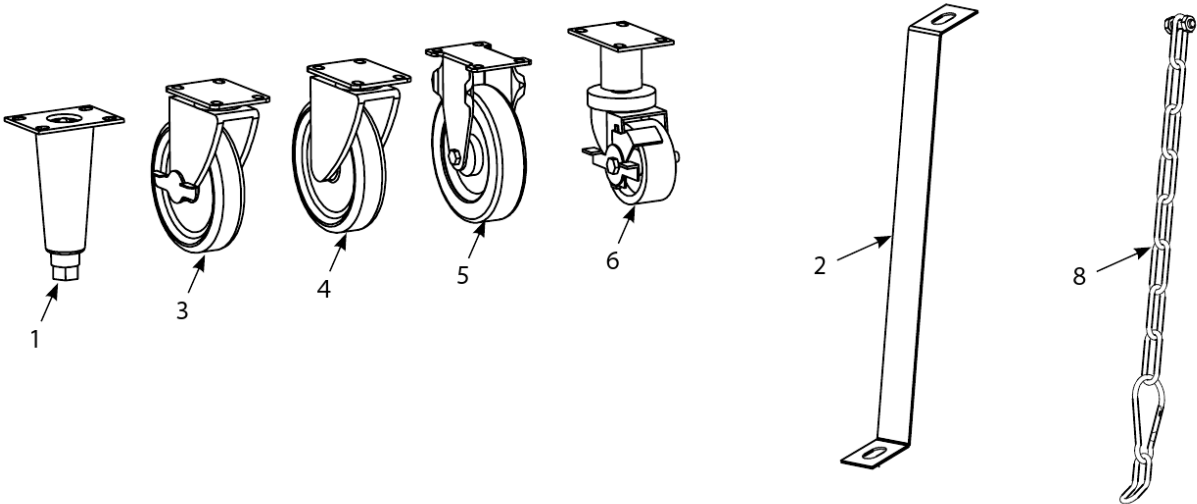

## Casters, Legs, and Associated Hardware

#	PART #	DESCRIPTION	QTY	Note
1	8263320	Leg - 4 Pack	4	
1a	8103168	Leg - Individual	1	
2	8261095	Anchor Strap Kit	1	
3	8100357	Caster with Brake - 5"	1	
3a	8261118	Caster, 5" Swivel w/Brake	1	
4	8100356	Caster without Brake - 5"	1	
4a	8261117	Caster, 5" Swivel w/o Brake	1	
5	8100378	Caster, Stationary- 5" Rigid	1	
6	8100651	Caster w/Brake –FootPrint II	1	
6a	8261130	Caster, 3" Swivel w/Brake	1	
7	8100750	Caster, 90° rigid	1	[1]
8	8260900	Kit, Chain Restraint	1	
9	8261113	Caster Fastener Kit	1	[2]

### PART NOTES:

- [1] - PMJ units
- [2] - one per caster or leg

# Component Boxes

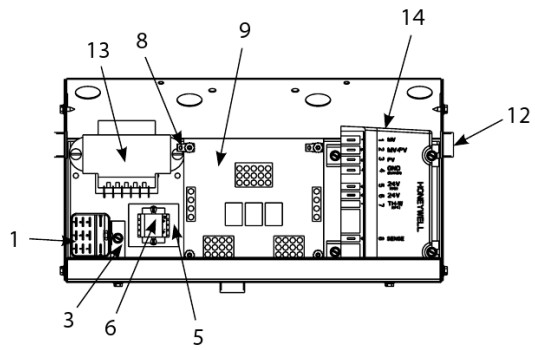
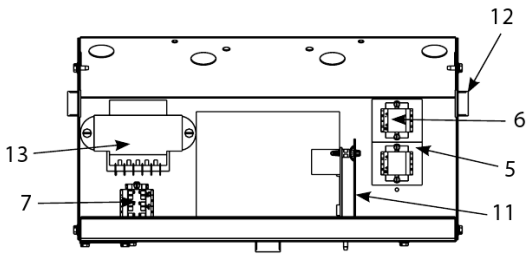
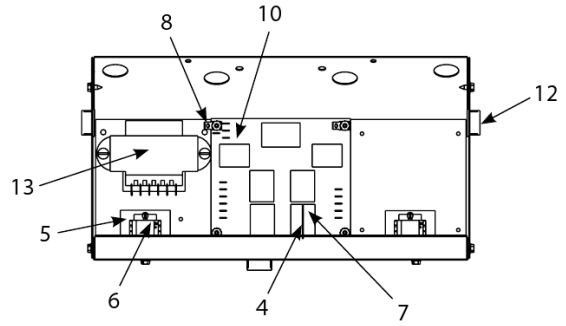
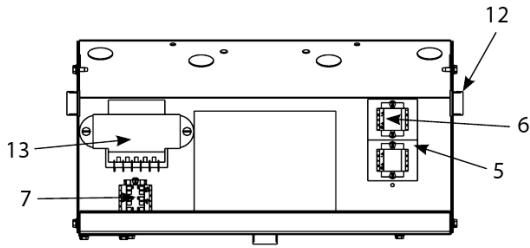

# Component Boxes

#	PART #	DESCRIPTION	QTY	Note
1	8070670	Relay, 24V DPDT	1	
2	8070833	Relay, DPDT 5A 12VDC Latch	1	
2a	8070834	Relay, SPDT 15A 12VDC Basket Lift	1	
3	2007176	Bracket, Relay	1	
4	8102243	Spring, Relay Retaining	1	
5	8160217	Insulation, Terminal Block Paper	1	
6	8101164	Block, One-Piece Screwless Terminal	1	
7	8101168	Terminal, Block Screwless End	1	[1]
8	8261337	Tab, 0.25-inch Terminal	5	
9	8065857	Interface Board, Electronic Ignition	1	
10	8262425	Control Board w/Wiring Harness	1	
11	8261546	Melt Cycle Timer Kit	1	
12	8100045	Bushing, .875 Dia. Hole 0.6875"	1	
13	8070800	Transformer, 100-120V/24V 50VA Filter and MIB	1	
13a	8074978	Transformer - Dual Voltage 100-120V/12V 30VA /24V 50VA	1	
13b	8070680	Transformer, 208V, 50/60Hz -24V 20VA	1	
13c	8075129	Transformer - Dual Voltage 208-240V	1	
14	8262898	Kit to replace Honeywell module with Fenwal 8075244	1	
15	8262898	Kit to replace Honeywell module with Fenwal 8075244	1	
16	8065879SP	Cable Assembly, Ignition Module, Interface Board to Module	1	
17	8065830SP	Cable, Ignition, with Ceramic Cover	1	
17a	8075008	Ignition Cable - 21"	1	
17b	8261721	Ignition Cable w/ Rajah	1	[2]
18	8074375	Connector, Rajah	1	
19	8071928	Flame Sensor Electrode	1	
20	WIR0165	Component Shield (Std.) Wiring	1	
20a	208250	Component Shield (Std.) Wiring (FV, Export only)	1	
21	8090349	Spacer, 4mm X 6mm Aluminum	1	
22	8261346	Spacer, Ignition Module	10	
23	WIR0148	Component Shield (with Mechanical Timer) Wiring	1	
23a	WIR0161	Component Shield (with Melt Cycle) Wiring (DV)	1	
23b	WIR0164	Component Shield (with Melt Cycle) Wiring	1	[3]
23c	WIR0160	Component Shield Wiring (DV)	1	
23d	WIR0163	Component Shield Wiring (FV)	1	
23e	WIR0162	Component Shield Wiring (FV, DV)	1	
24	WIR0258	Wiring, Component Shield	1	
25	WIR0329	Component Shield Drainswitch Wiring	1	[4]
26	WIR0349	Microswitch Wiring (DV)	1	
26a	WIR0350	Microswitch Wiring (DV)	1	

## PART NOTES:

- [1] - 230V, 50 Hz Filter Magic
- [2] - used with MJ45 ignition cable kit
- [3] - FV, 240V and below
- [4] - DV/FV

# Control Panel Assemblies, Flue Caps, and Related Items

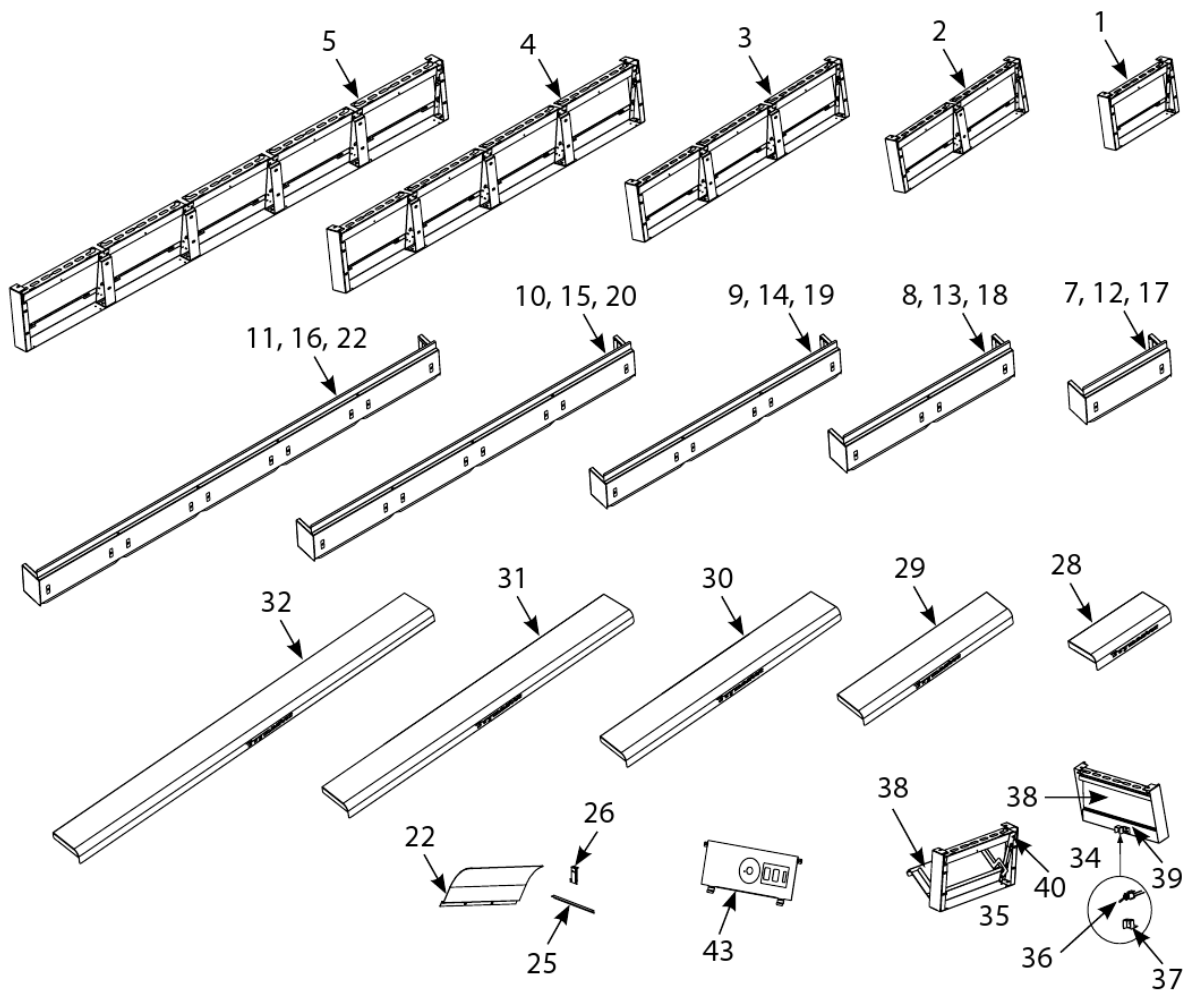

# Control Panel Assemblies, Flue Caps, and Related Items

#	PART #	DESCRIPTION	QTY	Note
1	1081550	Control Panel Assemblies, Single Station Fryer	1	
2	1081551	Control Panel Assemblies, Two Station Fryer	1	
3	1081552	Control Panel Assemblies, Three Station Fryer	1	
4	1081553	Control Panel Assemblies, Four Station Fryer	1	
5	1081554	Control Panel Assemblies, Five Station Fryer	1	
6	1064535	Control Panel Assemblies, Applebee's® Control Panel	1	
7	2106812	Flue Caps, PMJ 45, Single Station Fryer	1	
8	1064012	Flue Caps, PMJ 45, Two Station Fryer	1	
9	1064013	Flue Caps, PMJ 45, Three Station Fryer	1	
10	1064014	Flue Caps, PMJ 45, Four Station Fryer	1	
11	1064015	Flue Caps, PMJ 45, Five Station Fryer	1	
12	2106811	Flue Caps, PMJ 35, Single Station Fryer	1	
13	1064008	Flue Caps, PMJ 35, Two Station Fryer	1	
14	1064009	Flue Caps, PMJ 35, Three Station Fryer	1	
15	1064010	Flue Caps, PMJ 35, Four Station Fryer	1	
16	1064011	Flue Caps, PMJ 35, Five Station Fryer	1	
17	1064184	Burger King/Checkers, Two Station Fryer	1	
17a	1064188	Burger King/Checkers, Two Station Fryer (with buttons)	1	
18	1064185	Burger King/Checkers, Three Station Fryer	1	
18a	1064189	Burger King/Checkers, Three Station Fryer (with buttons)	1	
19	1064186	Burger King/Checkers, Four Station Fryer	1	
19a	1064190	Burger King/Checkers, Four Station Fryer (with buttons)	1	
20	1064187	Burger King/Checkers, Five Station Fryer	1	
20a	1064191	Burger King/Checkers, Five Station Fryer (with buttons)	1	
21	8241440	Applebee's® Dump Station Flue Cap	1	
22	9103557	Fryer's Friend 27"	1	
22a	9103207	Deflector, Flue, 3 holes	1	
23	9003933	Heat Shield, Flue	1	
24	8261017	Screw Kit, Flue Deflector	1	
25	9004253	Strip, Fluecap Retainer	1	
26	2006584	Support, Flue Cap	1	
27	2200810	Flue Guard, Panda Express	1	
28	8241409	Top Cap, Single Station Fryer	1	
29	8241410	Top Cap, Two Station Fryer	1	
30	8234940	Top Cap, Three Station Fryer	1	
31	8234941	Top Cap, Four Station Fryer	1	
32	8234942	Top Cap, Five Station Fryer	1	
33	8234990	Top Cap, Applebee's® Top Cap	1	
34	1064050	Control Panel Assembly with Thermostat Access Door (MJ 35), Complete, with Toggle Switch	1	
35	1064049	Control Panel Assembly with Thermostat Access Door (MJ 35), Complete, without Toggle Switch	1	
36	1064386SP	Toggle Switch	1	
37	8241394	Thermostat Access Door (MJ 35), Switch Guard	1	
38	2106930	Thermostat Access Door (MJ 35), Door Panel	1	
39	2108289	Thermostat Access Door (MJ 35), Frame, with Toggle	1	
40	2106832	Thermostat Access Door (MJ 35), Frame, without Toggle	1	

## Control Panel Assemblies, Flue Caps, and Related Items

#	PART #	DESCRIPTION	QTY	Note
41	1064235SP	Control Panel, MV with Mechanical Timer	1	[1]
42	<a href="#">2107026</a>	Controller Bezel, Blank Bezel, 2-vat unit	1	[1]
43	2106946	Control Panel, with toggle switch holes	1	[2]
44	2108686	Control Panel, without toggle switch holes	1	[2]
45	8262626	Carl's Jr. Risers, Flue Cap, Single	1	
46	8262627	Carl's Jr. Risers, Flue Cap, 2-vat	1	
47	8262628	Carl's Jr. Risers, Flue Cap, 3-vat	1	
48	8262629	Carl's Jr. Risers, Flue Cap, 4-vat	1	
49	<a href="#">8090171PK</a>	Thumbscrew	1	
50	<a href="#">8261351</a>	Nut Retainer, 0.25-20 Std. Fluecap	1	[3]

### PART NOTES:

- [1] - FPP
- [2] - PMJ
- [3] - for use on standard fluecap

# Controller

## Assemblies

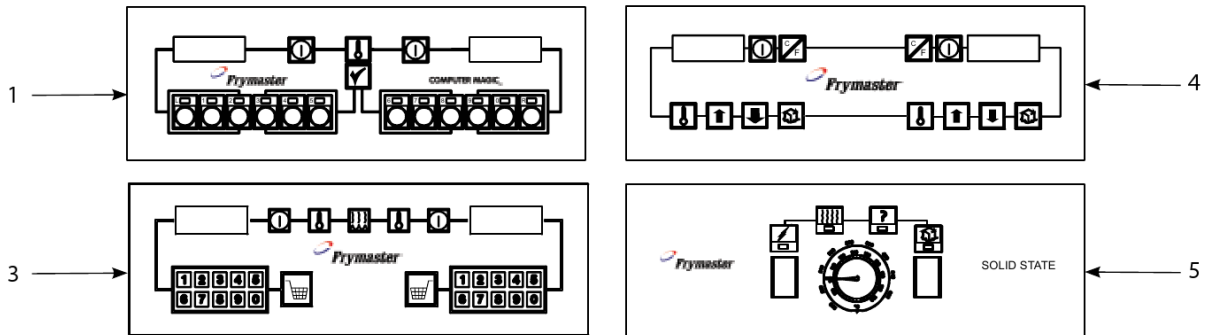

# Controller Assemblies

#	PART #	DESCRIPTION	QTY	Note
1	8232327	Computer Magic III.5, Full-vat	1	
1a	8262328	Computer Magic III.5, Full-vat (CE)	1	
1b	8262390	Computer Magic III.5, Dual-vat	1	
1c	8262391	Computer Magic III.5, Dual-vat (CE)	1	
1d	1067248	Computer Magic III.5, On-hood Remote Computer (FV, MJ 45)	1	
1e	8262280	Computer Magic III.5, In-hood Remote Computer (FV, MJ 45)	1	
2	8262327	Computer	1	
2a	8074642	Buffalo Wild Wings® Computer, Red (overlay)	1	
2b	8074644	Buffalo Wild Wings® Computer, White (overlay)	1	
2c	8074643	Buffalo Wild Wings® Computer, Violet (overlay)	1	
3	8262393	Basket Lift Timer, Full-vat	1	
3a	1064172	Basket Lift Timer, Full-vat (CE)	1	
3b	1064171	Basket Lift Timer, Dual-vat	1	
3c	1064173	Basket Lift Timer, Dual-vat (CE)	1	
4	8262394	Digital Controller, Full-vat	1	
4a	1064176	Digital Controller, Full-vat (CE)	1	
5	1063375	Solid State (Analog Controller), Dual-vat	1	
5a	1063369	Solid State (Analog Controller), Full-vat	1	
5b	8070847	Solid State (Analog Controller), Full-vat (overlay)	1	
5c	8100387	Knob	1	
6	2105046	Bezel - One-Controller	1	
6a	2307091	Controller Bezel, Computer, Single Station Tab Mount (for Screw Mount 09/08)	1	
6b	2105819	Bezel - Two-Controller	1	
6c	2307092	Controller Bezel, Computer, Two Station Tab Mount (for Screw Mount 09/08)	1	
6d	2106698	Bezel, Three-Controller	1	
6e	2307093	Controller Bezel, Computer, Three Station Tab Mount (for Screw Mount 09/08)	1	
7	2106960	Controller Bezel, No Computer, Single Station Fryer	1	
7a	2106961	Controller Bezel, No Computer, Two Station Fryer	1	
7b	2106962	Controller Bezel, No Computer, Three Station Fryer	1	
7c	2106766	Controller Bezel, No Computer, Applebee's® Spreader	1	
8	2107002	Controller Bezel, Blank Bezel, Single	1	
8a	2108578	Controller Bezel, Blank Bezel, Single (Applebee's® spreader)	1	
8b	2107026	Controller Bezel, Blank Bezel, 2-vat unit	1	
9	8063660	Sound Device, High Output for M100B	1	
9a	8103141	Sound Device, Universal SMT	1	
10	8064797	Buzzer	1	
11	8062071	Cable, Computer/Controller to Interface Board	1	
11a	8074199	Cable, 20-pin Controller to 15-pin Interface Board – SMT for fryer's with CM 3.5 controller.	1	
11b	8074397	Controller Harness, SMT	1	
12	8062079SP	Wiring Harness, Basket Lift Motor (6-pin female w/7 wires)	1	
13	8068555SP	Wire Assemblies**, For 202-250V Modular Basket Lift w/6-Pin Connector	1	
14	1061822SP	Wire Bundle - 100-120V Modular Basket Lift	1	

# Controller Assemblies

#	PART #	DESCRIPTION	QTY	Note
15	<a href="#">1061804SP</a>	Wire Bundle - 208-250V Modular Basket Lift	1	
16	<a href="#">8064798SP</a>	Basket Lift Power, Non-CE (6-pin male w/6 wires; connects to <a href="#">8062079SP</a> or 8068555SP)	1	
17	8066708SP	Basket Lift Power, CE (6-pin male plus 8064798)	1	
18	<a href="#">8073699</a>	Basket Lift Power, Non-CE/CE68"	1	[1]
19	<a href="#">8069777SP</a>	Thermostat Control Universal (control panel-end connections)	1	
20	<a href="#">8069778SP</a>	Thermostat Control Universal (component shield-end connections)	1	
21	<a href="#">8069779SP</a>	Basket Lift Universal (control panel-end connections)	1	
22	8069780SP	Basket Lift Universal (basket lift-end connections)	1	
23	<a href="#">8069781SP</a>	Wiring Bundle, Component Shield to Controller and Fryer Components (21-wire bundle)	1	
24	<a href="#">8261560</a>	Kit, 45 Series Wiring	1	[2]
25	<a href="#">8063549SP</a>	Interface Board	1	[3]
26	8066705SP	CE Non-Direct Wiring Power Supply	1	[4]
27	<a href="#">8064214SP</a>	Fryer to Fryer Drain Safety Switch (2-pin male w/two wires and 2-pin female w/two wires)	1	
28	<a href="#">8064215SP</a>	Fryer to Filter Drain Safety Switch (2-pin male w/two wires and 2-pin female w/two wires)	1	
29	<a href="#">8062071</a>	Cable, Computer/Controller to Interface Board	1	
30	<a href="#">8063383</a>	Remote Computer/Controller to Interface Board Cable, 15.0 feet (4.6m)	1	
31	<a href="#">8063388</a>	Harness, Main 20' Remote N Pot 15-pin Computer to Interface Board	1	
32	<a href="#">8064318</a>	Remote Computer/Controller to Interface Board Cable, 30.0 feet (9.1m)	1	
33	<a href="#">8063528</a>	Harness, Main 7.5' BK 15-pin Computer to Interface Board	1	
34	<a href="#">8063529</a>	Remote Computer/Controller Cable Assemblies, 8.5 feet (2.6m)	1	
35	<a href="#">8063530</a>	Remote Computer/Controller Cable Assemblies, 10.5 feet (3.2m)	1	
36	<a href="#">8063531</a>	Remote Computer/Controller Cable Assemblies, 12.6 feet (3.8m)	1	
37	8068350	Remote Computer/Controller Cable Assemblies w/Junction Box and Mounting Bracket, One Computer/Controller	1	
38	8068349	Remote Computer/Controller Cable Assemblies w/Junction Box and Mounting Bracket, Two Computers/Controllers	1	
39	8068348	Remote Computer/Controller Cable Assemblies w/Junction Box and Mounting Bracket, Three Computers/Controllers	1	
40	8068351	Remote Computer/Controller Cable Assemblies w/Junction Box and Mounting Bracket, Four Computers/Controllers	1	

## PART NOTES:

- [1] - 12-pin male w/6 wires, connects to [1061822SP](#) or [1061804SP](#)
- [2] - contains [8069777SP](#) through [8069781SP](#)
- [3] - interface board to fryer components; 12-pin male w/5 wires
- [4] - power cords joined in junction box

# Door Assembly

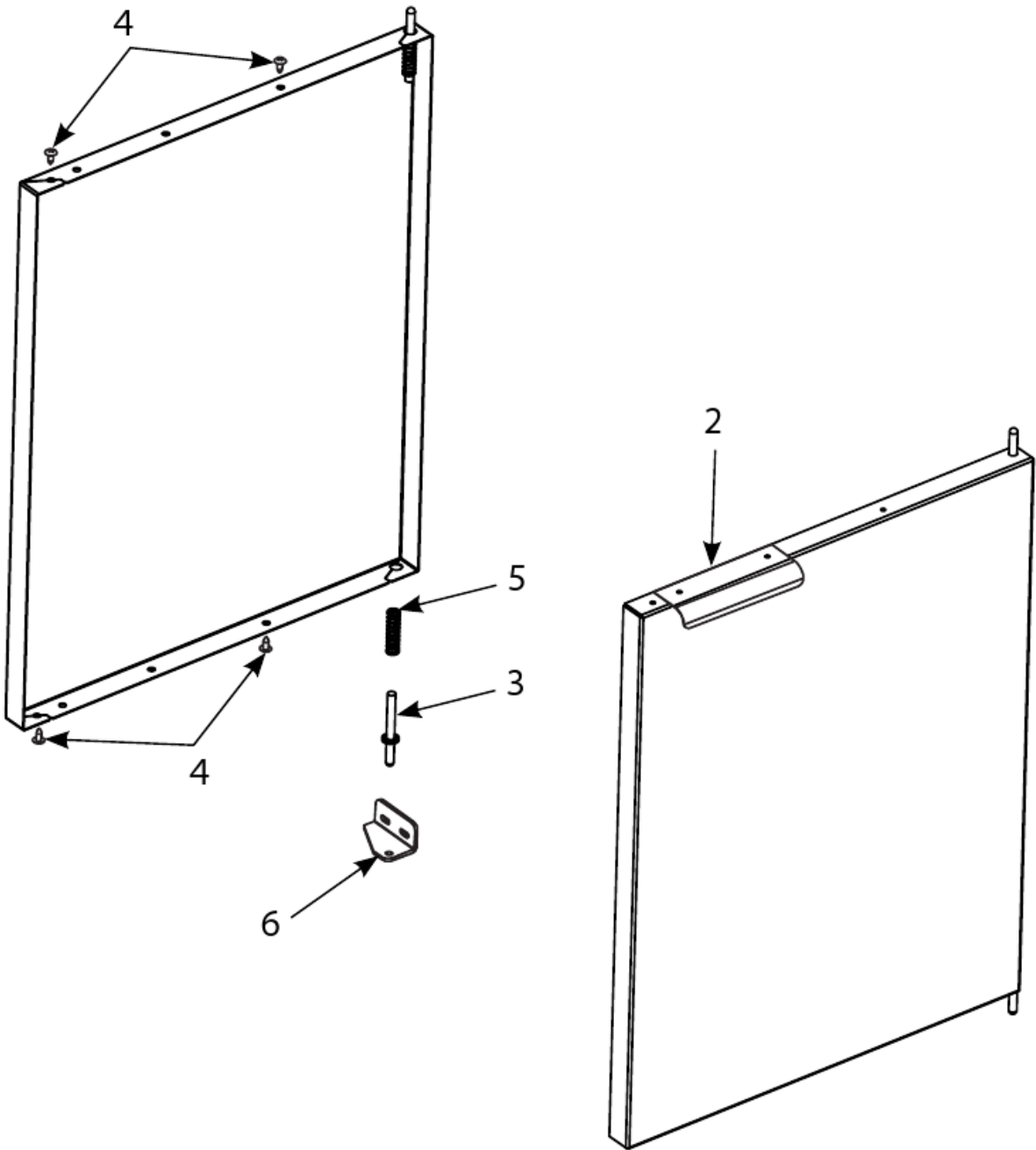

# Door Assembly

#	PART #	DESCRIPTION	QTY	Note
1	1063965	Door Assembly	1	
2	2304960	Handle, Eurolook Door	1	
3	2106739	Pin, Door Hinge	1	
4	8090266	Screw, 10 x 0.5-inch Phillips Head ZP	1	
5	8261343	Spring - Door Pin Hinge	1	
6	2324707	Hinge, Lower, Right	1	
6a	2314707	Hinge, Lower, Left	1	
7	8102346	Door Magnet - Horizontal	1	[1]
8	1063931	Door, Applebee's® Filter/Dump Station	1	

**PART NOTES:**

[1] - white

# Drain System Components - Drain Tube System

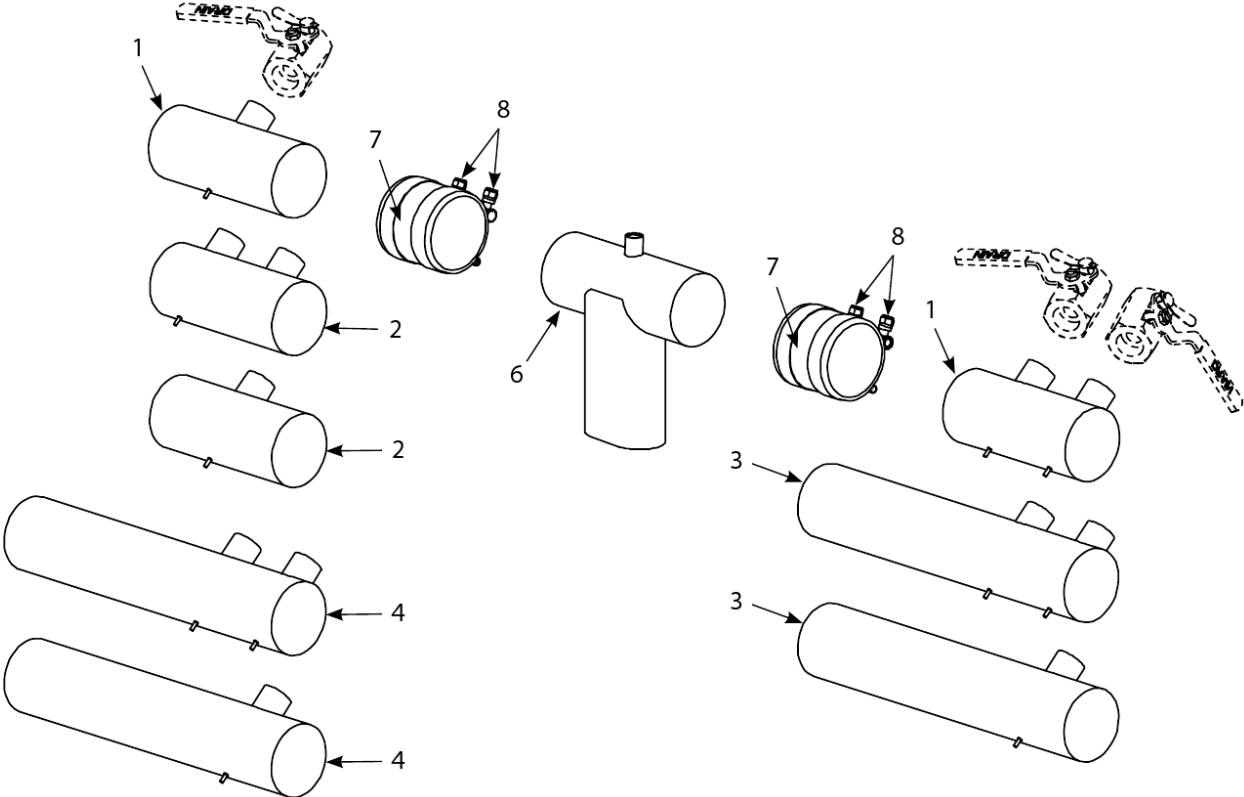

## Drain System Components - Drain Tube System

#	PART #	DESCRIPTION	QTY	Note
1	<a href="#">8234625</a>	Drain Tube, Short Full-Vat Left Open/Right End Closed	1	
1a	<a href="#">8234624</a>	Drain Tube, Left/Right End Short, Dual-Vat 3"	1	
2	<a href="#">8234643</a>	Drain Tube, Full-Vat, Short, Open Both Ends	1	
2a	<a href="#">8234642</a>	Drain Tube, Left/Right Open Short, Dual-Vat 3"	1	
3	<a href="#">8234639</a>	Drain Tube, Long Full-Vat Left Open/Right End Closed	1	
3a	<a href="#">8234638</a>	Drain Tube, Right End Long, Dual-Vat 3"	1	
4	<a href="#">8234641</a>	Drain Tube, Long Full-Vat Open Both Ends	1	
4a	<a href="#">8234640</a>	Drain Tube, Left/Right Open Long, Dual-Vat 3"	1	
5	<a href="#">2006473</a>	Drain Tubes, Spreader, Open Long	1	
5a	<a href="#">2006474</a>	Drain Tubes, Spreader, Open Short	1	
6	<a href="#">8234740</a>	Drain Outlet, Both Ends Open	1	
6a	<a href="#">8234741</a>	Drain Outlet, One End Closed	1	
7	<a href="#">8160729</a>	Sleeve, Drain Connector	1	
8	<a href="#">8090969</a>	Clamp 3"	1	
9	<a href="#">8072484</a>	Solenoid Valve - 0.25"	1	
10	<a href="#">8110932</a>	Vent Tube, Teflon 0.375" OD Bulk	1	
11	<a href="#">8103904</a>	Quick Connect - 0.25" x 90°	1	
12	8111071	Tube, 0.25-inch OD Teflon Manifold Vent	1	
13	<a href="#">8102493</a>	Elbow, 90° 0.125-inch NPT x 0.25-inch Quick Connect	1	
14	<a href="#">8102492</a>	Fitting, Quick-Connect Straight	1	
15	<a href="#">8160630</a>	Cap, Vinyl Black	1	
16	<a href="#">8090047</a>	Nut, Cap- 0.25-20 High Profile S/S	1	
17	KIT6214	Round Drain Boot Kit	1	[1]

**PART NOTES:**

[1] - includes 2 clamps and 1 boot

# Filter Boxes

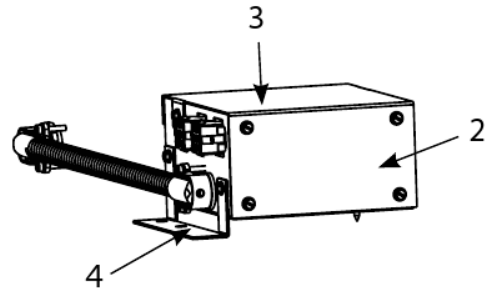
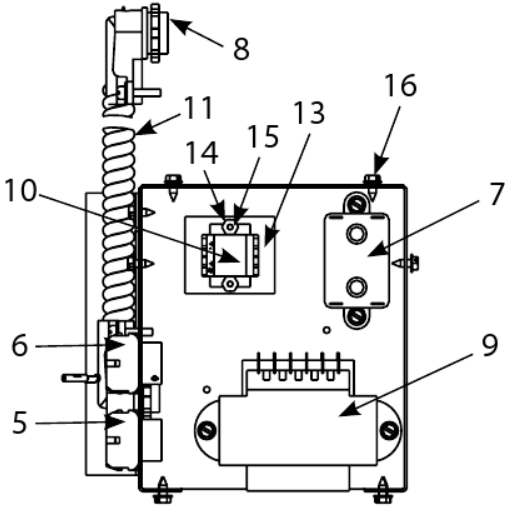
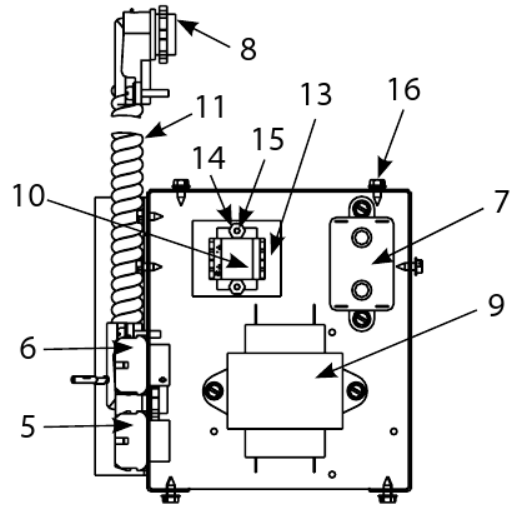
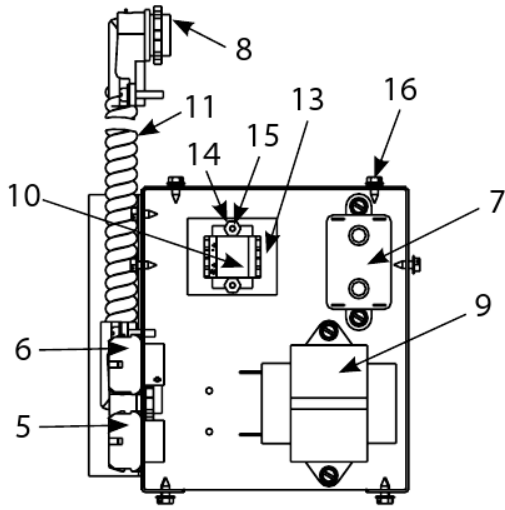

# Filter Boxes

#	PART #	DESCRIPTION	QTY	Note
1	1063981	Complete Box Assemblies, 120V	1	
1a	1063988	Complete Box Assemblies, 208-250V	1	
1b	1063989	Complete Box Assemblies, 208-240V	1	
2	2006836	Components, Filter Box	1	
3	<a href="#">2006837</a>	Components, Lid	1	
4	2006838	Components, Mount	1	
5	8067494	Plug Assembly, FPIII Non-Reversing	1	
5a	<a href="#">8101421</a>	Harness, Control Circuit	1	[1]
6	8068021	Plug Assembly, Filter Box	1	
7	<a href="#">8070012</a>	Filter Relay - 18A 24VAC	1	
8	<a href="#">8070141</a>	Components, Connector, 0.375" Right Angle	1	
9	<a href="#">8070800</a>	Transformer, 100-120V/24V 50VA Filter and MIB	1	
9a	<a href="#">8070680</a>	Transformer, 208V, 50/60Hz -24V 20VA	1	
9b	<a href="#">8075129</a>	Transformer - Dual Voltage 208-240V	1	
10	<a href="#">8101164</a>	Block, One-Piece Screwless Terminal	1	
11	8121704	Conduit, Flex 0.375" x 13.5"	1	
12	8120636	Conduit, Flex 0.375" x 15"	1	
13	<a href="#">8160217</a>	Insulation, Terminal Block Paper	1	
14	<a href="#">8261366</a>	Nut - #4-40 Keps Hex	25	
15	<a href="#">8261359</a>	Screw - #4-40 x 0.75" Slotted Round Head	25	
16	<a href="#">8090360</a>	Screw, 8 x 0.375-inch Hex Washer Slot Head	1	
17	<a href="#">8101421</a>	Harness, Control Circuit	1	

**PART NOTES:**

[1] - to Control Circuits

# Filter Pan Assembly

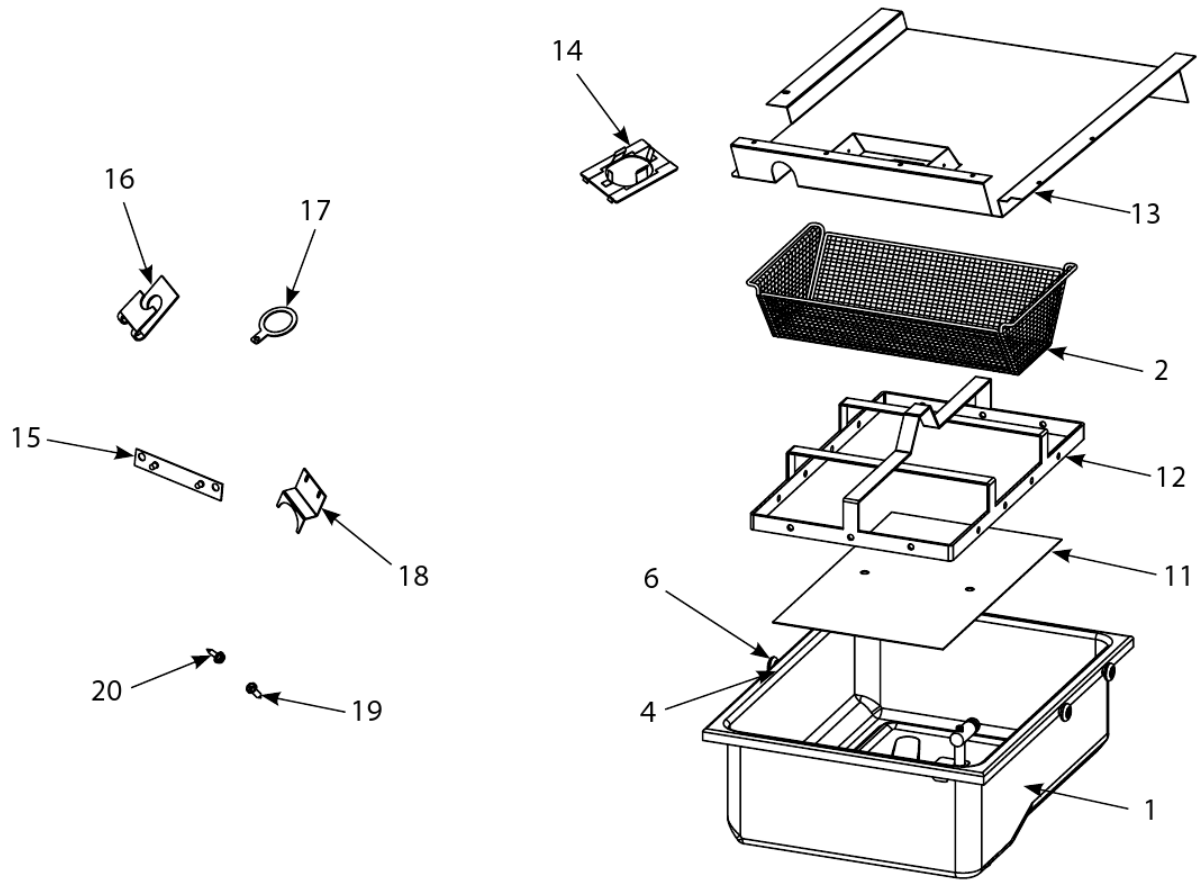

# Filter Pan Assembly

#	PART #	DESCRIPTION	QTY	Note
1	8237508SP	Filter Pan No Rollers July 2008	1	
1a	1081232SP	Filter Pan With Rollers	1	
2	8103161	Crumb Tray	1	
3	8130568	Plug, 0.125" SS NPT, Sq-Head	1	
4	8261372	Nut Grip 0.25-inch 0.25-20 Hex NP	10	
5	8261392	O-Ring	1	
6	8102198	Roller, Filter Pan and Rail	1	
7	8091025	Nylon Slides	1	
8	8262603	Rail Set, Filter Pan Rail	1	
9	8261979	Filter Pan Roller Kit	1	
10	8090191	Washer, Lock 0.25 Spring ZP	1	
11	8122024	SanaGrid Filter Screen, Standard Size Filter Pan	1	
12	8103760	Ring, Hold Down	1	[1]
13	8236412	Lid, Filter Pan, FPP	1	[2]
13a	8235334	Lid, Filter Pan, FMPH	1	
14	8235294	Splash Shield	1	[2]
15	1065141	Bracket, Burner Heat Shield Mounting	1	[3]
16	8090173	Clip, Tinnerman	1	[4]
17	2009732	Lip, Suction Fitting	1	[4]
18	2009715	Brace, Drain Spout	1	[5]
19	8261371	Screw - #8 x 0.5" Hex Head ZP	25	
20	8090785	Screw - #14 x 0.75" Slotted Hex Washer Head	1	
21	2006310	Support, Rear Pan Rail	1	
22	8090743	Screw - #4-40 x 1" Pan Head SS	1	
23	8030170	Filter Paper, 16.5" x 25.75"	1	[6]
23a	8030002	Powder, Filter	1	[7]
24	8102800	Carl's Jr. Filter Leaf	1	
25	8160757	O-ring, Optional Filter Leaf	1	

## PART NOTES:

- [1] - 8102910, FMP, see also Lid, Filter Pan, FPP
- [2] - included in kit 8262109, 8262110, and 8262111
- [3] - MJ35
- [4] - included in kits 8262109, 8262110, and 8262111
- [5] - included in kits 8262110 and 8262111
- [6] - box of 100 sheets
- [7] - box of 80 individual packs

# Frypots

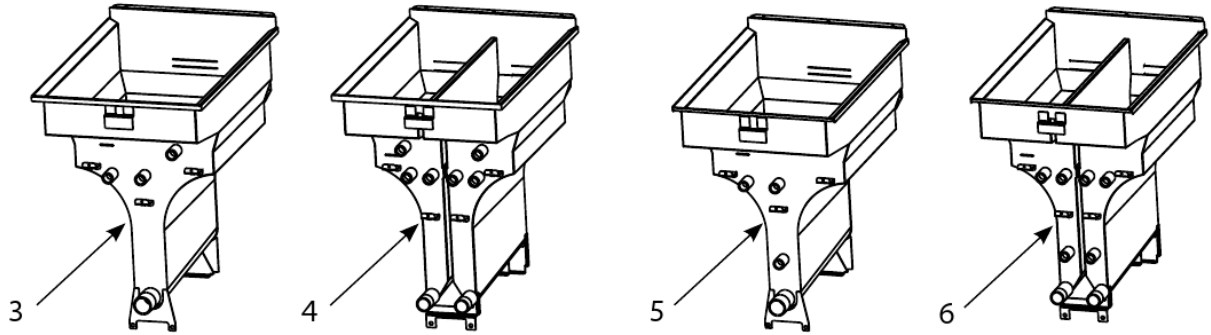
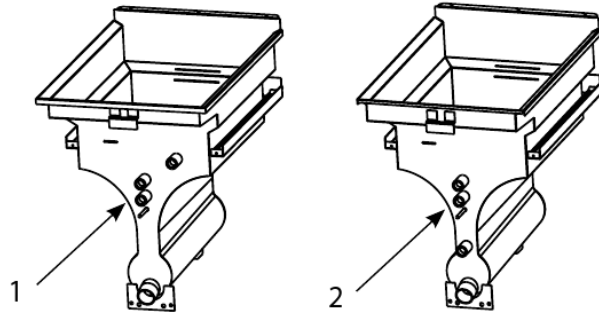

# Frypots

#	PART #	DESCRIPTION	QTY	Note
1	<a href="#">1064115SP</a>	PMJ 35, Full-vat, Stainless Steel, (Power Shower)	1	
1a	<a href="#">1069776SP</a>	Frypot - Full-vat, Stainless Steel, Single Non-filter For XMJ135V	1	
1b	<a href="#">8234492SP</a>	PMJ 35, Full-vat, Stainless Steel (Pre-Pro MJ35)	1	
2	<a href="#">1068362SP</a>	PMJ 35, Full-vat, Stainless Steel (Front Flush) Service Part	1	
2a	<a href="#">1067671SP</a>	PMJ 35, Full-vat, Stainless Steel (Power Shower) Export	1	
2b	<a href="#">1069727SP</a>	PMJ 35, Full-vat, Stainless Steel (PMJ) Non-Filter Service Part	1	
2c	<a href="#">1068363SP</a>	PMJ 35, Full-vat, Stainless Steel (Domestic, Power Shower) Service Part	1	
3	<a href="#">1062547SP</a>	PMJ 45, Full-vat, Stainless Steel (Power Shower) Service Part FP47 only	1	
4	<a href="#">1067740SP</a>	PMJ 45, Dual-vat, Stainless Steel (CE)	1	
5	<a href="#">1065868SP</a>	PMJ 45, Full-vat, Stainless Steel (Front Flush) Service Part FPP45	1	
6	1065869	PMJ 45, Dual-vat, Stainless Steel (Front Flush)	1	
7	<a href="#">1067681SP</a>	PMJ 45, Full-vat, Stainless Steel (Power Shower) Service Part FPP45	1	
8	<a href="#">1067740SP</a>	PMJ 45, Dual-vat, Stainless Steel (CE)	1	

# Ignitors

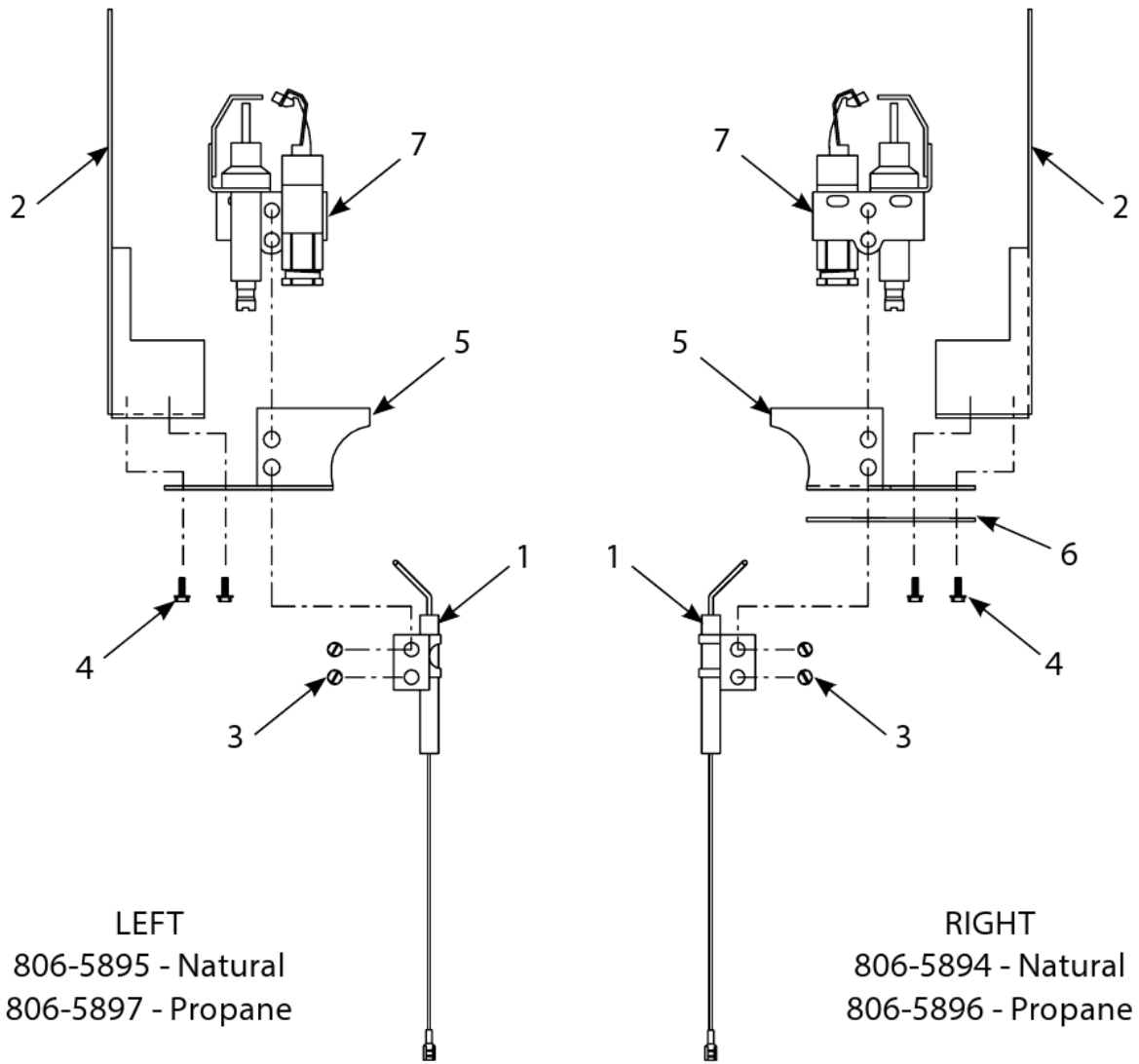

# Ignitors

#	PART #	DESCRIPTION	QTY	Note
1	8071928	Flame Sensor Electrode	1	
2	9102077	Pilot Mount	1	
3	8090121	Screw, 10-32 x 0.5" Hex Head	1	
4	8090500	Screw, 10 x 0.5-inch Hex Washer Head 410 SS	1	
5	9102078	Plate, Pilot, Left	1	
5a	9102079	Plate, Pilot, Right	1	
6	9102080	Heat Shield	1	
7	8071707	Ignitor, Natural	1	
7a	8071708	Ignitor, Propane	1	

# Oil Return Assembly

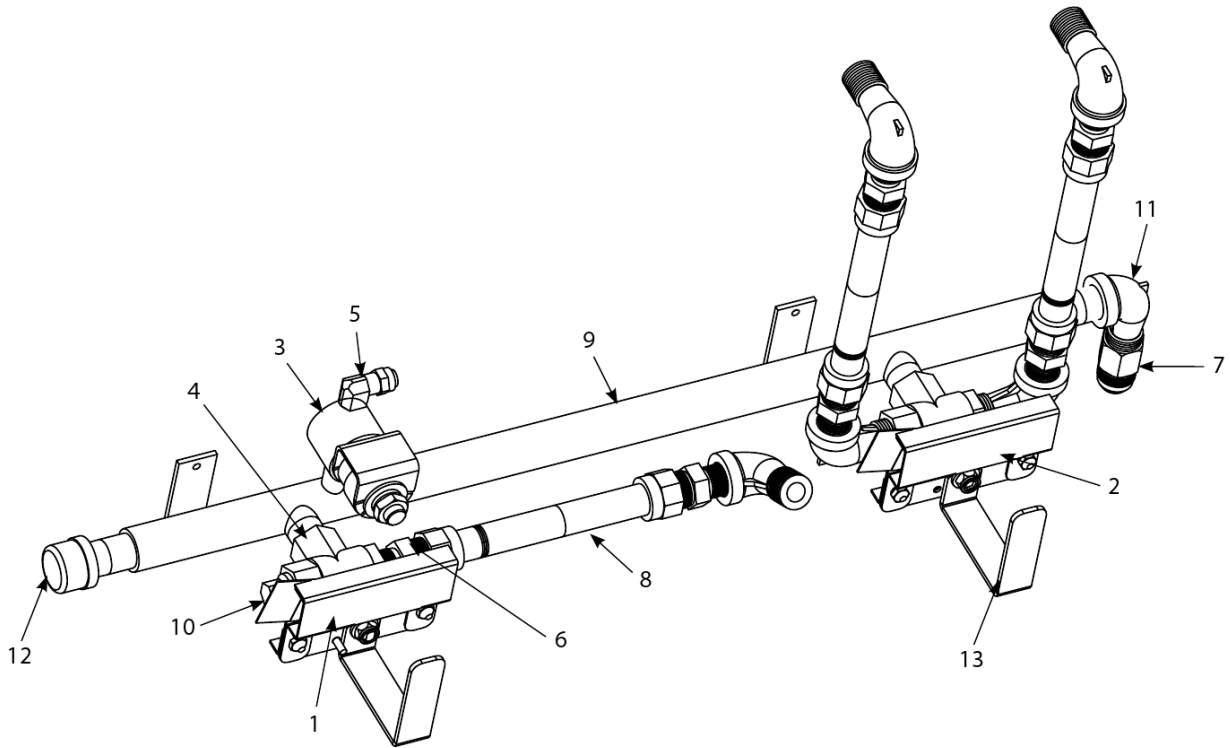

# Oil Return Assembly

#	PART #	DESCRIPTION	QTY	Note
1	1064002	Valve Assembly, Full-vat	1	
2	<a href="#">1064003</a>	Valve Assembly, Dual-vat	1	
3	<a href="#">8072484</a>	Solenoid Valve - 0.25"	1	
4	<a href="#">8101003</a>	Valve, 180° 3-way Ball	1	
5	<a href="#">8103904</a>	Quick Connect - 0.25" x 90°	1	
6	<a href="#">8101668</a>	Male Adaptor - 0.625" OD x 0.5"	1	
7	<a href="#">8101669</a>	Female Adaptor - 0.875" OD x 0.5"	1	
8	<a href="#">8101680</a>	Flexline - 0.625" OD x 6.5" L	1	
9	<a href="#">8102791</a>	Manifold, Oil Return	1	
10	<a href="#">8130463-FRY</a>	Plug - 0.5" NPT	1	
11	<a href="#">8130165</a>	Elbow - 0.5" x 90° NPT Street	1	
12	<a href="#">8130469</a>	Cap, 0.5-inch NPT Pipe	1	
13	<a href="#">8160644</a>	Oil Return Handle, Grip	1	

# Oil Return Components

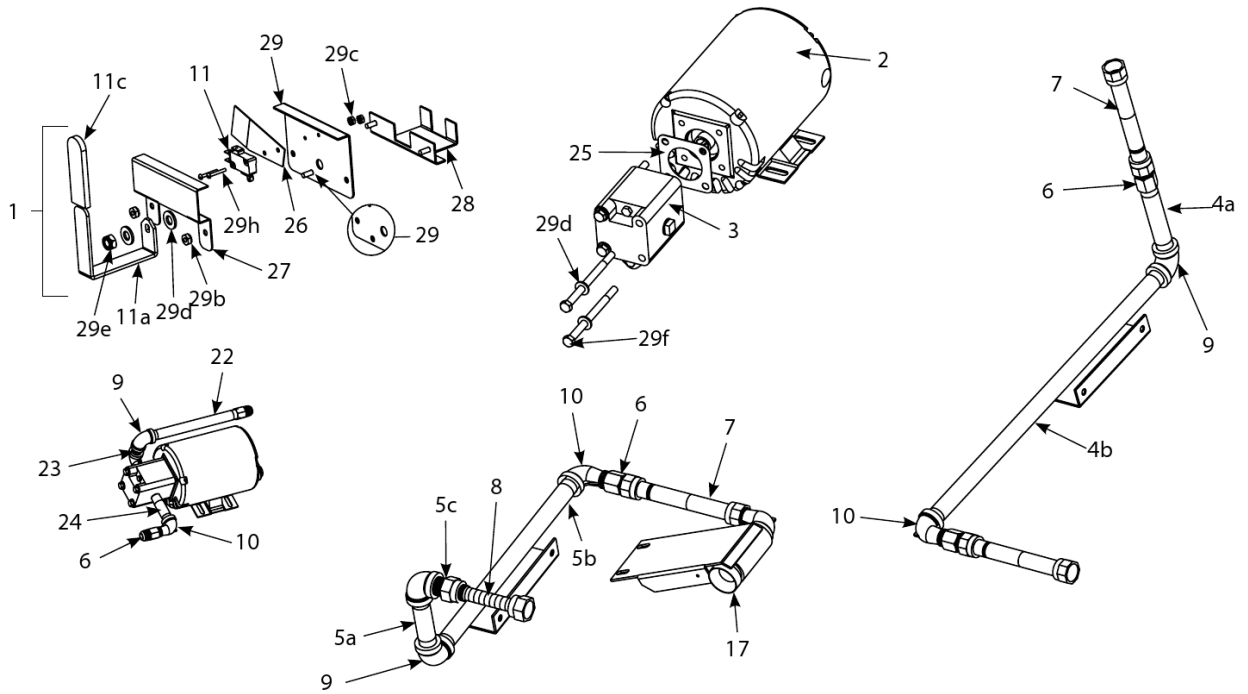

# Oil Return Components

#	PART #	DESCRIPTION	QTY	Note
1	1064002SP	Handle Assemblies, Oil Return Valve, FV Oil Return Assembly, MJ45	1	
1a	1064003SP	Handle Assemblies, Oil Return Valve, DV Oil Return Assembly, MJ45	1	
1b	1069265SP	Handle Assemblies, Oil Return Valve, FV Oil Return Assembly, MJ 35	1	
2	8261712	Motor and Gasket Kit - 115V/50-60 Hz	1	
2a	8261756	Motor and Gasket Kit - 208V/50-60 Hz	1	
2b	8261270	Motor and Gasket Kit - 220-240V/50-60 Hz	1	
2c	8261755	Motor and Gasket Kit - 250V/50-60 Hz	1	
3	8261264	Pump Kit - 4 GPM	1	
4	1063987	Filter Return Manifold	1	[1]
4a	8130251	Nipple, 0.5" x 4.5" NPT BM Pipe	1	
4b	8234739	Filter Return Manifold, Bracket, Suction Nipple	1	
5	1063986	Filter Suction Manifold	1	[1]
5a	8130247	Nipple, 0.5 x 3.5" NPT BM	1	
5b	8234737	Filter Suction Manifold, Bracket, Suction Nipple	1	
5c	8101668	Male Adaptor - 0.625" OD x 0.5"	1	
5d	8101339	Filter Suction Manifold, Flexline, 4.5"	1	
6	8101669	Female Adaptor - 0.875" OD x 0.5"	1	
7	8101680	Flexline - 0.625" OD x 6.5" L	1	
8	8101160	Flexline - Oil Return - 3" L	1	
9	8130062	Elbow - 0.5" BM x 90°	1	
10	8130165	Elbow - 0.5" x 90° NPT Street	1	
11	8072104	Microswitch	1	[2]
11a	2009065	Oil Return Handle, Handle (MJ45)	1	[2]
11b	2009065	Oil Return Handle, Handle (MJ45)	1	[2]
11c	8160644	Oil Return Handle, Grip	1	[2]
12	8110746-FRY	Aluminum Tape – 50 yard roll	1	[3]
13	8110861	Foam Insulation – by the foot	1	[4]
14	8071472	Heater Tape 120V 40w 56"	1	[5]
15	8071473	Heater Strip Assembly, 240V, 70W 56"	1	[6]
16	8068065	Heater Tape, 100V, 25W, 18"	1	
16a	8065933	Heater Tape, 120V, 25W, 18"	1	
16b	8069245	Heater Tape, 120V, 25W, 36"	1	
16c	8066731	Heater Tape, 120V, 40W, 56"	1	
16d	8071098	Heater Strip Assembly, 240V, 25W 18"	1	
16e	1065768	Heater Tape, 250V, 25W, 18"	1	
16f	1065849	Heater Tape, 250V, 45W, 36"	1	
16g	8066733	Heater Tape, 250V, 70W, 56"	1	
16h	1065011	Heater Tape, Extension Harness	1	
16i	8262100	Heater Tape, Kit, Retrofit 120V Heater	1	
17	8236486	Connector, Female Suction	1	
18	8130463-FRY	Plug - 0.5" NPT	1	
19	8101003	Valve, 180° 3-way Ball	1	
20	8072484	Solenoid Valve - 0.25"	1	
21	8110932	Vent Tube, Teflon 0.375" OD Bulk	1	

# Oil Return Components

#	PART #	DESCRIPTION	QTY	Note
22	<a href="#">8130275</a>	Nipple, 0.5-inch x 9-inch	1	
23	<a href="#">8130087</a>	Nipple, 0.5-inch NPT x 1.5-inch (3.8 cm)	1	
24	<a href="#">8130460</a>	Nipple, 0.5-inch X 3.0-inch NPT	1	
25	<a href="#">8160093</a>	Gasket - Pump/Motor	1	
26	<a href="#">8160220</a>	Insulation, Microswitch	1	[2]
27	<a href="#">9002110</a>	Cover - Microswitch	1	[2]
28	<a href="#">8068342</a>	Support, Oil Return Valve	1	[2]
29	<a href="#">8069385</a>	Support, Microswitch Mount, Full-vat	1	[2]
29a	<a href="#">9002112</a>	Support, Microswitch Mount, Dual-vat	1	[2]
29b	<a href="#">8261376</a>	Nut - #10-32 Keps Hex	10	[2]
29c	<a href="#">8261366</a>	Nut - #4-40 Keps Hex	25	[2]
29d	<a href="#">8090194</a>	Flat Washer - 0.3125" ZP	1	[2]
29e	<a href="#">8090056</a>	Nut - 0.3125"- 24, Hex Head, Nylon Lock	1	[2]
29f	<a href="#">8090514</a>	Cap Screw - 0.3125" 18 NC Hex	1	[2]
29g	WIR0220	Support, Microswitch Mount, Pump Wiring Assembly	1	[2]
29h	<a href="#">8261359</a>	Screw - #4-40 x 0.75" Slotted Round Head	25	[2]
30	<a href="#">8262118</a>	Heater Tape Retrofit, Kit, 100 VAC	1	
30a	<a href="#">8262119</a>	Heater Tape Retrofit, Kit, 120 VAC	1	
30b	<a href="#">8262120</a>	Heater Tape Retrofit, Kit, 220/240 VAC	1	
30c	<a href="#">8262121</a>	Heater Tape Retrofit, Kit, 250 VAC	1	

**PART NOTES:**

- [1] - see additional components below
- [2] - included with Item 1
- [3] - 150' roll
- [4] - sold by the foot
- [5] - for 120V fryers
- [6] - for 208-240V fryers

# Thermostats and Timers

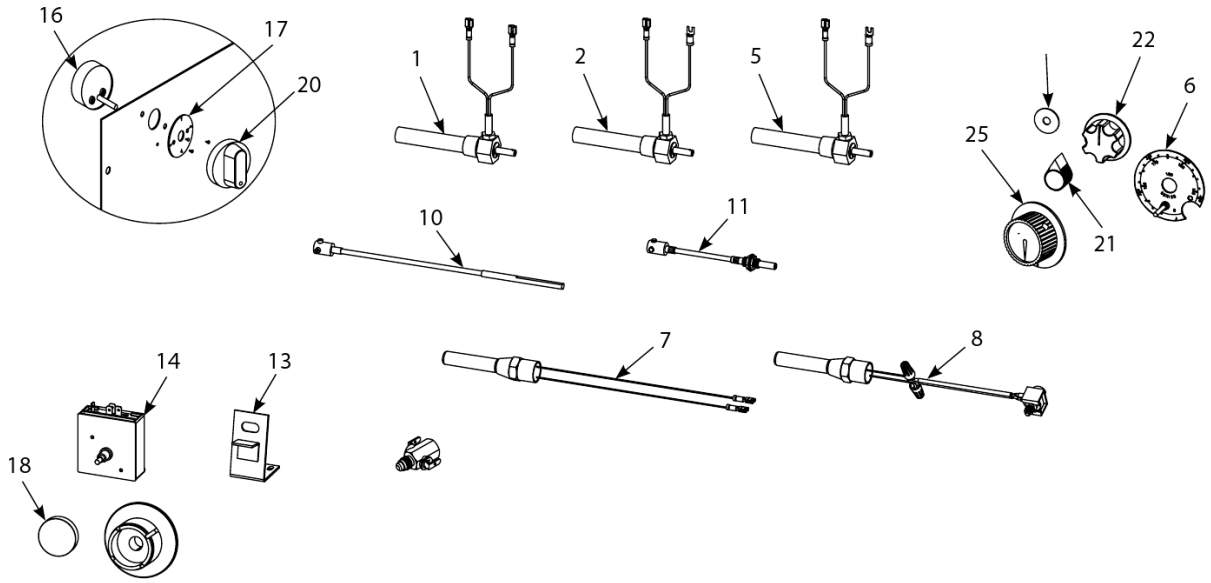

# Thermostats and Timers

#	PART #	DESCRIPTION	QTY	Note
1	<a href="#">8060183</a>	Operating Thermostat Assembly, Fenwall, With Two Blue Insulated Push-on Terminals, 4" (MJ35 & 45, Non-CE)	1	
2	<a href="#">8065816</a>	Operating Thermostat Assembly, Fenwall, With One Wire Push-on, One Fork Terminal, 3" (MJ35, Non-CE)	1	
3	<a href="#">8067972</a>	Operating thermostat	1	
4	<a href="#">1067036</a>	Operating Thermostat Assembly, Fenwall, With One Wire Push-on, One Fork Terminal, 4" (MJ45, CE)	1	
5	<a href="#">8069617</a>	Operating Thermostat Assembly, Fenwall, With One Blue Insulated Push-on, One Fork Terminal, 4" (MJ35 & 45, CE)	1	
6	<a href="#">8060087SP</a>	Operating Thermostat Assembly, Fenwall, Thermostat Dial Plate Assembly	1	
7	<a href="#">8261177</a>	Thermostat, High-Limit 425°F/218°C	1	
8	<a href="#">8067550</a>	High-Limit Thermostat, 218°C High-limit (CE)	1	[1]
9	<a href="#">8100999</a>	Flex Shaft, Control Panel Mount Assembly, 9.25" overall	1	
10	<a href="#">8100345</a>	Shaft, 7.25" Thermostat Flexible Extension	1	
11	<a href="#">8101651</a>	Shaft, 5.50" Thermostat Flexible Extension	1	
12	<a href="#">8100276</a>	Shaft, 2.25" Thermostat Flexible Extension	1	
13	<a href="#">9002071</a>	Mounting Bracket	1	
14	<a href="#">8262698</a>	Timers, Basket Lift, 15-minute Electronic Timer, Single	1	
15	<a href="#">8262699</a>	Timers, Basket Lift, 15-minute Electronic Timer, Multi-vat System	1	
16	<a href="#">8100585</a>	Timers, Basket Lift, 15-minute Mechanical Timer	1	
17	<a href="#">9101551</a>	Mechanical Timer - Basket Lift - 15 minute	1	
18	<a href="#">8100387</a>	Knob	1	
19	<a href="#">8261395</a>	Plug Button	10	
20	<a href="#">8101287</a>	Knob, 15-minute Mechanical Timer	1	
21	<a href="#">8100110</a>	Thermostat Knob	1	
22	<a href="#">8100334</a>	Knob, with Skirt	1	
23	<a href="#">8100388</a>	Knob, 1" Black	1	
24	<a href="#">8261575</a>	Kit, Retrofit 5-minute Timer	1	
25	<a href="#">8074134</a>	Butterfly/Envelope Adapter	1	[2]
26	<a href="#">1064386SP</a>	Toggle Switch	1	
27	<a href="#">8064206</a>	Probe Assembly, Temperature	1	
28	<a href="#">2100681</a>	Probe Guard	1	

**PART NOTES:**

- [1] - includes adapter for gas valve hookup
- [2] - CE; included in [8103442](#)

# Wiring Harnesses, Pin Terminals, and Power Cords

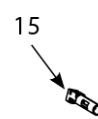
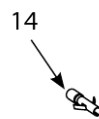
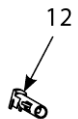
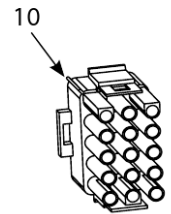
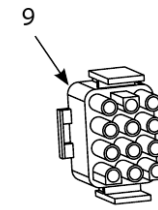
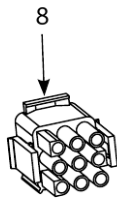
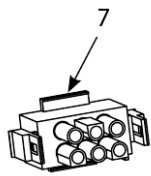
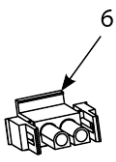
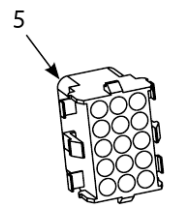
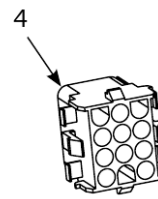
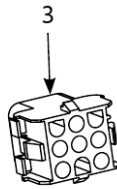
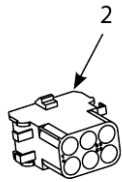
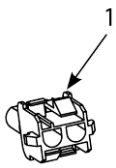

# Wiring Harnesses, Pin Terminals, and Power Cords

#	PART #	DESCRIPTION	QTY	Note
1	8071068	2-Pin Female	1	
2	8070158	6-Pin Female	1	
3	8070156	9-Pin Female	1	
4	8070159	12-Pin Female	1	
5	8070875	15-Pin Female	1	
6	8071067	2-Pin Male	1	
7	8070157	6-Pin Male	1	
8	8070155	9-Pin Male	1	
9	8070160	12-Pin Male	1	
10	8070804	15-Pin Male	1	
11	8261332	Terminal, Female Disconnect Pin	25	
12	8261333	Terminal, Male Split Pin	25	
13	8072518	Plug, Mate-N-Lock	1	[1]
14	8261331	Terminal, M&L Female Split Pin	25	
15	8261336	Terminal, M&L Male Split Pin	25	
16	8070154	Power Cord - 120V w/Ground Plug	1	[2]

**PART NOTES:**

- [1] - Dummy Pin
- [2] - Power Cord

# Cabinetry - FPP, FMP Model Cabinetry

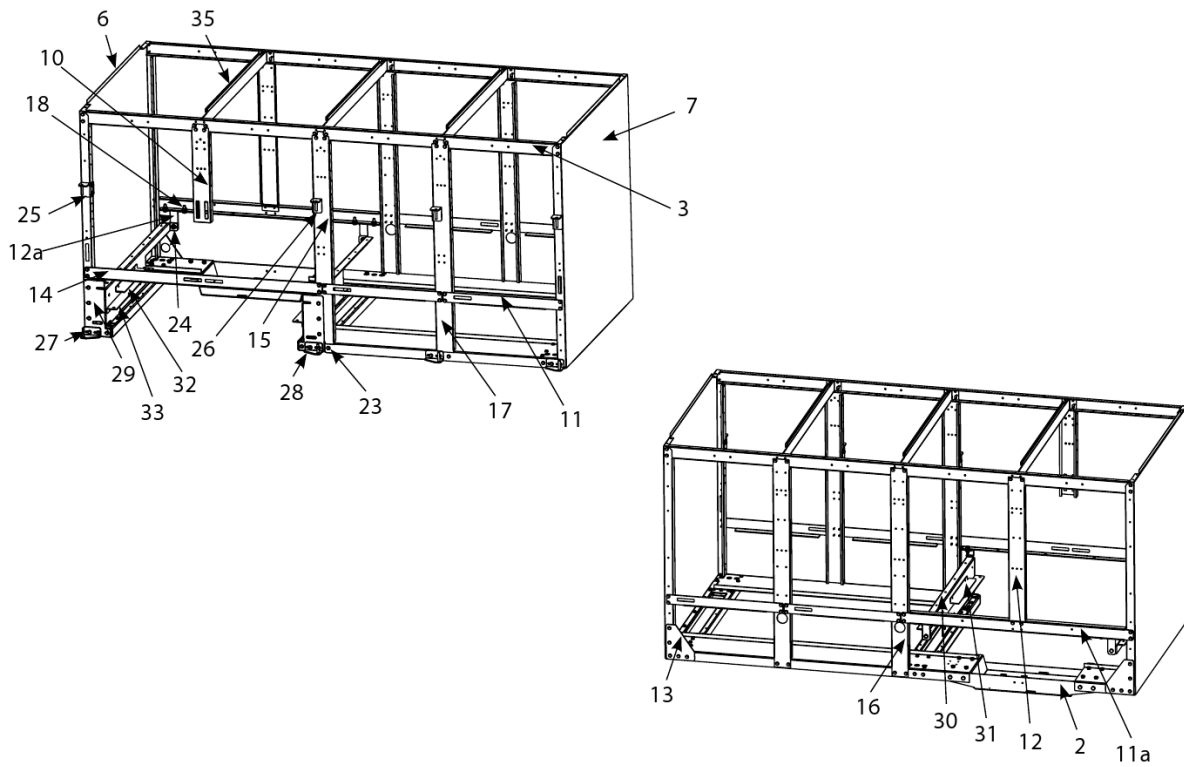

## Cabinetry - FPP, FMP Model Cabinetry

#	PART #	DESCRIPTION	QTY	Note
1	1069088	Cabinet Assemblies, Two Station Fryer, Stainless	1	
1a	1069089	Cabinet Assemblies, Two Station Fryer, Cold Rolled Steel	1	
1b	1069090	Cabinet Assemblies, Three Station Fryer, Stainless	1	
1c	1069091	Cabinet Assemblies, Three Station Fryer, Cold Rolled Steel	1	
1d	1069092	Cabinet Assemblies, Four Station Fryer, Stainless	1	
1e	1069093	Cabinet Assemblies, Four Station Fryer, Cold Rolled Steel	1	
1f	1069094	Cabinet Assemblies, Five Station Fryer, Stainless	1	
1g	1069095	Cabinet Assemblies, Five Station Fryer, Cold Rolled Steel	1	
1h	1064525	Cabinet Assemblies, Applebee's® Dump Station	1	
2	1063785	Base Assemblies, Two Station Fryer	1	
2a	1064019	Base Assemblies, Three Station Fryer	1	
2b	1064020	Base Assemblies, Four Station Fryer	1	
2c	1064021	Base Assemblies, Five Station Fryer	1	
3	9007730	Brace, Top Cabinet, Two Station Fryer	1	
3a	9009430	Brace, Top Cabinet, Three Station Fryer	1	
3b	9009318	Brace, Top Cabinet, Four Station Fryer	1	
3c	<a href="#">2005474</a>	Brace, Top Cabinet, Five Station Fryer	1	
4	2006901	Back Panels, Upper	1	
4a	<a href="#">2006906</a>	Back Panels, Upper	1	
4b	2106608	Back Panels, Upper (Use with cabinet assemblies.), Use with 1064036. 1064038. 1064039.	1	
4c	2106895	Back Panels, Upper (Use with cabinet assemblies.), Use with 1064037, 1064039.	1	
5	<a href="#">2006905</a>	Back Panels, Lower (Use with cabinet assemblies.), Use with 1064036, 1064038, 1064039, 1064051, 1064053.	1	
5a	<a href="#">2006908</a>	Back, Lower Cabinet, Aluminized	1	
5b	2106897	Back, Lower Cabinet, Stainless Steel	1	
5c	<a href="#">2106874</a>	Back Panels, Lower (Use with cabinet assemblies.), Use with 1064037, 1064039, 1064052.	1	
5d	2008567	Back Panels, Lower, Use with 1064525	1	[1]
6	<a href="#">2116893SP</a>	Left Side - Painted	1	
6a	<a href="#">2016917SP</a>	Left Side SS	1	
6b	2116933	Side, Left Cabinet, Stainless Steel with hole	1	
6c	2016934	Side, Left Cabinet, Stainless Steel with hole (Cold Rolled Steel)	1	
7	<a href="#">2126893</a>	Right Side - Painted	1	
7a	<a href="#">2026917</a>	Right Side SS	1	
7b	2126933	Side, Right Cabinet, Stainless Steel with hole	1	
7c	<a href="#">2026934</a>	Side, Right Cabinet, Stainless Steel with hole	1	[2]
8	<a href="#">2200927</a>	Air/Heat Shield, 31"	1	
8a	<a href="#">2200928</a>	Air/Heat Shield, 15.5"	1	
9	<a href="#">2006908</a>	Back, Lower Cabinet, Aluminized	1	[3]
9a	2106897	Back, Lower Cabinet, Stainless Steel	1	[3]
10	2002235	Bracket, Component Box	1	
11	2001953	Brace, Front Cabinet	1	
11a	<a href="#">2006057</a>	Brace, Cabinet Cross	1	
12	<a href="#">2006062</a>	Support, Cabinet upper Rear	1	
12a	<a href="#">2006310</a>	Support, Rear Pan Rail	1	

## Cabinetry - FPP, FMP Model Cabinetry

#	PART #	DESCRIPTION	QTY	Note
13	2006346	Gusset, Rear Cabinet	1	
14	2006486	Brace, Front Cross	1	
15	2006892	Post, Front Door Long	1	
16	2006894	Post, Rear Cabinet Long	1	
17	2006911	Post, Front Cabinet Long	1	
18	<a href="#">8261389</a>	Screw - 0.25"-20 x 0.75" Hex Head ZP	10	
19	<a href="#">9107443</a>	Top Connecting Strip	1	
20	9106650-FRY	Channel, Top Connecting Strip	1	
21	<a href="#">8235810</a>	Connecting Strip, Frypot	1	
22	<a href="#">9104617</a>	Connecting Strip, blunt point, 0.5" sides, 20.70" long	1	[4]
23	<a href="#">8261374</a>	Screw - #10 x 0.5" Hex Head	25	
24	<a href="#">8261368</a>	Nut - 0.25-20 Serrated Flange	1	
25	<a href="#">8234727</a>	Hinge Assembly, Left Upper	1	
26	<a href="#">8234728</a>	Hinge Assembly, Right Upper	1	
27	<a href="#">8234745</a>	Hinge Assembly, Left Lower	1	
28	<a href="#">8234746</a>	Hinge Assembly, Right Lower	1	
29	2204180	Rail Assembly, Left	1	[5]
29a	<a href="#">8090495</a>	Nut, 0.25-inch - 20 Press	1	
30	1069083	Rail Assembly, Right	1	[6]
31	2224183	Rail, RH Filter Pan Retaining	1	
32	2214483	Rail, LH Filter Pan Retaining	1	
33	2204182	Rail, Slide	1	
34	2006935	Stop, Filter Rail	1	
35	<a href="#">9007326</a>	Divider	1	
36	KIT0293	Joiner Kit, Applesbee's® Dump Station	1	
37	<a href="#">2109291</a>	Top Connecting Strip, Fryer-to-Fryer	1	
38	<a href="#">8090193</a>	Flat Washer - 0.25" Nylon	1	
39	<a href="#">8102346</a>	Door Magnet - Horizontal	1	

**PART NOTES:**

- [1] - Applesbee's® Dump Station
- [2] - Cold Rolled Steel
- [3] - three and five station fryers
- [4] - Applesbee's Fryer to Filter
- [5] - (nut separate)
- [6] - (nut included)

# Drain System Components - Drain Valves, FPPFMP Models

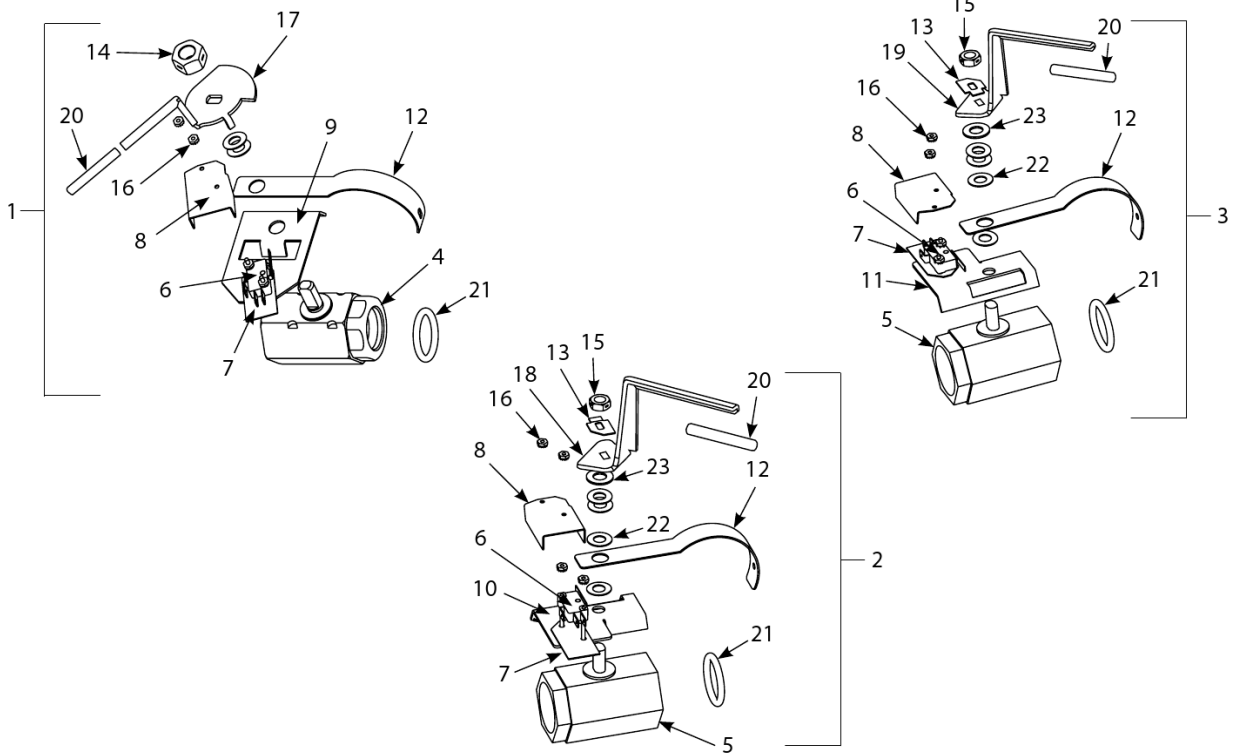

## Drain System Components - Drain Valves, FPPFMP Models

#	PART #	DESCRIPTION	QTY	Note
1	1063760	Drain Valve Assemblies, Full-vat	1	
2	1068104SP	Drain Valve Assemblies, Dual-vat, Left	1	
3	1086185SP	Drain Valve Assemblies, Dual-vat, Right	1	
4	8101018	Drain Valve, 1.25", Left Drain Valves, Full-vat, 1.25-inch Drain Valve	1	
5	8101114	Drain Valves, Dual-vat, 1-inch Drain Valve	1	
6	8072103	Microswitch Drain Safety Switch, Microswitch	1	
7	8160220	Insulation, Microswitch Drain Safety Switch, Insulation	1	
8	9012348	Cover, Dual-Vat Left Drain Safety Switch Drain Safety Switch, Cover	1	
9	8068137	Bracket Assembly, Full-Vat Drain Safety Switch Drain Safety Switch, Bracket, Full-vat	1	
10	1062671	Bracket Assembly, Dual-Vat Left Drain Safety Switch Drain Safety Switch, Bracket, Dual-vat, Left	1	
11	1062672	Bracket Assembly, Dual-Vat Right Drain Safety Switch Drain Safety Switch, Bracket, Dual-vat, Right	1	
12	2006496	Support, Drain Tube	1	
13	9002936	Retainer Nut (FV)	1	
13a	9002934	Retainer, Dual-Vat Drain Valve Nut Retainer Nut (DV)	1	
14	8090540	Nut, Lock 0.5-inch-13 Hex 2-Way ZPNut, 2-way Lock (FV)	1	
15	8090539	Nut, 0.375-16 2-Way Lock Nut, 2-way Lock (DV)	1	
16	8260237	25Nut, 4-40 Keps Hex with External Tooth	25	
17	8241602	Handle, Valve, Full-vat	1	
18	8241637	Handle, Valve, Dual-vat, Left	1	
19	8241636	Handle, Valve, Dual-vat, Right	1	
20	8160639	Cap, Vinyl Red Sleeve, Handle	1	
21	8160135	O-ring	1	
22	8101165	Washer, Teflon Drain Valve Washer, Teflon	1	
23	8090196	Washer, 0.375-inch SAE Flat Washer, Flat	1	