

SERVICE AND OWNER'S MANUAL

TCF SERIES

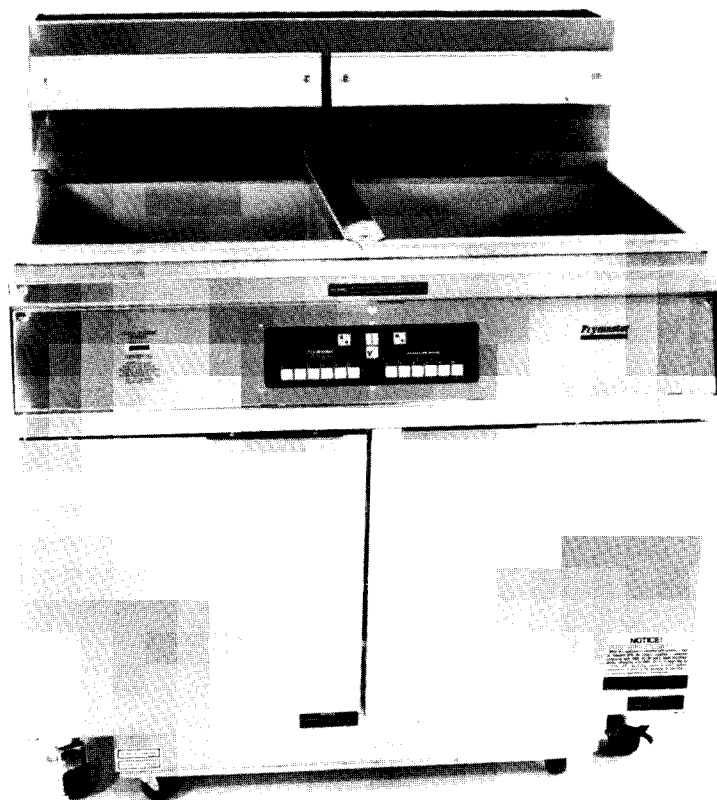

Frymaster[®]



 *Frymaster*

The Frymaster Corporation, 8700 Line Avenue 71106, P. O. Box 51000, Shreveport, Louisiana 71135-1000
318-865-1711 FAX 318-862-2394

PRINTED IN THE U.S.A.

SERVICE HOTLINE
1-800-551-8633

819-5227 8/97



WARNING
IMPROPER INSTALLATION, ADJUSTMENT, ALTERATION, SERVICE OR MAINTENANCE CAN CAUSE PROPERTY DAMAGE, INJURY, OR DEATH. READ THE INSTALLATION, OPERATING, AND MAINTENANCE INSTRUCTIONS THOROUGHLY BEFORE INSTALLING OR SERVICING THIS EQUIPMENT.

FOR YOUR SAFETY
DO NOT STORE OR USE GASOLINE OR OTHER FLAMMABLE VAPORS OR LIQUIDS IN THE VICINITY OF THIS OR ANY OTHER APPLIANCE

POST IN PROMINENT LOCATION THE INSTRUCTIONS TO BE FOLLOWED IN THE EVENT THE USER SMELLS GAS. THIS INFORMATION CAN BE OBTAINED BY CONSULTING THE LOCAL GAS SUPPLIER.

WARNING
THIS PRODUCT CONTAINS CHEMICALS KNOWN TO THE STATE OF CALIFORNIA TO CAUSE CANCER AND/OR BIRTH DEFECTS OR OTHER REPRODUCTIVE HARM.

¹Operation, ²installation, and ³servicing of this product could expose you to airborne particles of glass wool fibers and/or carbon monoxide. Inhalation of airborne particles of glass wool fibers is known to the State of California to cause cancer. Inhalation of carbon monoxide is known to the State of California to cause birth defects or other reproductive harm.

NOTICE
The Commonwealth of Massachusetts requires any and all gas products to be installed by a licensed plumber or pipe fitter.

TABLE OF CONTENTS

SECTION	PAGE
1. Parts Ordering/Service Information	1
2. Important Information	2
3. Installation Instructions	3
4. Operating Instructions	5
5. Ventilation and Clearance	7
6. Draining and Filtering Instructions	7
7. Care and Cleaning of Your Fryer and Filter System	9
8. Computer Magic III - Operating Instructions	10
9. Computer Magic III - Programming Instructions	12
10. Troubleshooting Guide - Fryer	15
Troubleshooting Guide — Filter System	
11. Parts List	21
12. Service Procedures	31
13. Preventive Maintenance	39
14. Wiring Diagrams	40
15. Interface Board Test-Point Chart	45
16. Specifications	46

1. PARTS ORDERING/SERVICE INFORMATION

Parts orders may be placed directly with your local Frymaster Parts Distributor. A list of Frymaster Parts Distributors was included with the fryers when shipped from the factory. If you do not have access to this list, please contact the Frymaster Service Department at 1-800-551-8633 or 1-318-865-1711.

To speed up your order, the following information is required:

Model Number _____
Serial Number _____
Type of Gas or Voltage _____
Item Part Number _____
Quantity Needed _____

Service may be obtained by contacting your local Frymaster Authorized Service Center. See your Authorized Service Agency listing. Service may also be obtained by calling the Frymaster Service Department. The following information will be needed in order to assist you efficiently:

Model Number _____
Serial Number _____
Gas Type _____
Nature of the Problem _____
Any other information which may be helpful in solving your service problem.

RETAIN AND STORE THIS MANUAL IN A SAFE PLACE FOR FUTURE USE.

2. IMPORTANT INFORMATION

INTRODUCTION

The TCF Series are tube-type fryers with heating tubes running through the frypot. These models come in full, open-pot arrangements manufactured to operate on the type gas specified by the user; i.e., natural, propane, or manufactured gas. The instructions contained in this manual should be read thoroughly before attempting to operate these fryers.

This equipment is made in America and has American sizes of hardware. All hardware metric conversions are approximate and can vary in size.

OPERATING, INSTALLATION, AND SERVICE PERSONNEL

Operating information for FRYMASTER equipment has been prepared for use by qualified and/or authorized operating personnel only.

All installation and service on FRYMASTER equipment must be performed by qualified, certified, licensed, and/or authorized installation or service personnel.

DEFINITIONS

QUALIFIED AND/OR AUTHORIZED OPERATING PERSONNEL

Qualified or authorized operating personnel are those who have carefully read the information in this manual and have familiarized themselves with the equipment functions or have had previous experience with the operation of equipment covered in this manual.

QUALIFIED INSTALLATION PERSONNEL

Qualified installation personnel are: individuals, a firm, corporation, or a company which either in person or through a representative are engaged in, and are responsible for the installation of gas-fired appliances. Qualified installation personnel must be experienced in such work, be familiar with all gas precautions

required, and have complied with all requirements of state and local codes.

QUALIFIED SERVICE PERSONNEL

Qualified service personnel are those familiar with FRYMASTER equipment and have been authorized by THE FRYMASTER CORPORATION. All authorized service personnel are required to be equipped with a complete set of service parts manuals and stock a minimum amount of parts for FRYMASTER equipment.

A list of Frymaster Factory Authorized Service Centers was included with the fryer when shipped from the factory. If you do not have access to this list, please contact the Frymaster Customer Service Department, using the number listed on the front of this manual. Failure to use qualified service personnel will void the Frymaster warranty.

SHIPPING DAMAGE CLAIM PROCEDURE

For your protection, please note that the FRYMASTER equipment was carefully inspected and packed by skilled personnel before leaving the factory. The transportation company assumes full responsibility for safe delivery upon acceptance of the equipment.

What to do if equipment arrives damaged:

1. **FILE CLAIM FOR DAMAGES IMMEDIATELY** — Regardless of extent of damage.
2. **VISIBLE LOSS OR DAMAGE** — Be sure this is noted on the freight bill or express receipt and is signed by the person making the delivery.
3. **CONCEALED LOSS OR DAMAGE** — If damage is unnoticed until equipment is unpacked, notify freight company or carrier immediately, and file a concealed damage claim. This should be done within fifteen (15) days of date of delivery. Be sure to retain container for inspection.

FRYMASTER DOES NOT ASSUME RESPONSIBILITY FOR DAMAGE OR LOSS INCURRED IN TRANSIT.

3. INSTALLATION INSTRUCTIONS

PROPER INSTALLATION IS ESSENTIAL FOR EFFICIENT TROUBLE-FREE OPERATION. ANY ALTERATION OF THE EQUIPMENT VOIDS THE FRYMASTER WARRANTY.

Upon arrival, inspect the fryer carefully for visible or concealed damage. See Shipping Damage Claim Procedure in Section 2.

The fryer(s) must be installed with a six-inch (150 mm) clearance at both sides and back adjacent to combustible construction; zero inches for noncombustible construction. A minimum of 24 inches (600 mm) should be provided at the front of the fryer(s) door.

THE APPLIANCE AREA MUST BE KEPT FREE AND CLEAR OF COMBUSTIBLES.

FRYERS EQUIPPED WITH CASTERS

1. Frymaster fryers equipped with casters must be installed in a manner that will allow the fryer drain line to drain properly. (See Caster Installation Instruction sheet included with fryer literature.)
2. Adequate means must be provided in order to avoid the splashing of hot liquid without depending on the gas connector and any quick-disconnect device or its associated piping. This can be accomplished by attaching restraining chains/cables to the outside of the front casters and securing the chains/cables to the floor.
3. Installation shall be made with a gas connector that complies with the latest editions of the Standard for Connectors for Movable Gas Appliances ANSI Z21.69 and Addenda, Z21.69, and a quick-disconnect device that complies with the latest edition of the Standard for Quick-disconnect Devices for Use With Gas Fuel, ANSI Z21.41.

NATIONAL CODE REQUIREMENTS

The type of gas for which the fryer is equipped is stamped on the data plate attached to the inside of the fryer door. Connect a fryer stamped "NAT" only to natural gas; connect those stamped "PRO" only to propane gas. When installing gas fryers in the United States, the installation must conform with the latest edition of the National Fuel Gas Code, ANSI Z223.1. In addition, all local codes must be followed. In CANADA, installation must conform with the latest edition of Standard CANI-B149.1 and 2, "Installation Codes for Gas Burning Appliances & Equipment". Again, all local codes must be complied with.

When installing any type of gas-fired commercial kitchen equipment, Standard No. 96 and Standard 211 of the National Fire Protection Association must be followed implicitly. A copy of the standards may be obtained from the National Fire Protection Association, Battery March Park, Quincy, Massachusetts 02269.

In Australia, this appliance must be installed by an authorized person, in accordance with the manufacturer's instructions, local gas, and electrical regulations, and requirements of AA601, "Installation Requirements for Gas Burning Appliances".

ELECTRICAL GROUNDING INSTRUCTIONS

All electrically operated appliances must be electrically grounded in accordance with local codes; or in the absence of local codes, with the latest edition of the National Electric Code, ANSI/NFPA NO. 70. A wiring diagram is located on the inside of the fryer door. The electrical supply must be 120 VAC, 60 HZ. The current carrying capacity for filtration power cord must be seven (7) amps; the current carrying capacity for control circuit power cord must be two (2) amps.

WARNING

This appliance is equipped with two (2) three-prong (grounding) plugs, one for the control circuit of the fryer, the other for the filter pump. They must be plugged directly into properly grounded three-prong receptacles. **DO NOT CUT OR REMOVE THESE GROUNDING PRONGS FROM THESE PLUGS.**

In the event of a power failure, the fryer(s) will automatically shut down. Should this occur, turn the gas control valve to the OFF position. **DO NOT ATTEMPT TO USE THE FRYER DURING POWER OUTAGE.**

GAS CONNECTIONS AND PIPE SIZE

The size of the gas line is very important. If the line is too small, the gas pressure at the burner manifold will be low. This will cause slow recovery and delayed ignitions. The incoming gas supply line should be a minimum of 1-1/2". All single fryers require a 3/4" connection. Batteries of two and three fryers require a 1" connection. NOTE: Runs of more than 20 feet and more than 4 fittings or elbows require an increase of one pipe size. For gases with heating values less than 800 BTU per cubic foot, increase the pipe by one size. For LP gases, the next smaller pipe size may be used. If in doubt about pipe size, consult the local gas company.

Before connecting new pipe to your Frymaster fryer, the pipe must be thoroughly blown out to dispose of all foreign particles. If these foreign particles get into the burner and controls, they will cause improper and sometimes dangerous operation.

Do not use pipe thread compound; instead, use Loctite PST56765 sealant on the first two threads only. This will prevent fouling the controls and clogging the pilot and main burner orifices.

Check the serial plate on the fryer door to determine if fryer burner is set up for the proper gas type before connecting the quick disconnect piping from the building gas supply pipe.

Minimum incoming gas pressure for NATURAL GAS is 6.5 in. W.C. (1.61kPa). Maximum incoming gas pressure for NATURAL GAS is 14 in. W.C. (3.48kPa). Minimum incoming gas pressure for LP GAS is 12 in. W.C. (3.0kPa). Maximum incoming pressure for LP GAS is 14 in. W.C. (3.48kPa).

Be sure to check all plumbing with a soap solution for leaks. **DO NOT USE** matches, candles, or other ignition sources in checking for leaks.

WARNING

IF GAS ODORS ARE DETECTED, THE FRYER GAS SUPPLY MUST BE SHUT OFF AT THE MAIN SHUT-OFF VALVE, AND THE LOCAL GAS COMPANY OR AUTHORIZED SERVICE AGENCY CONTACTED FOR SERVICE.

Burner operating gas pressure can be checked at this time. Burner manifold pressure for NATURAL GAS must be 4.0 in. W.C. (1.0kPa). Burner manifold pressure for LP GAS must be 11.0 in. W.C. (2.74kPa).

NOTE: This should be checked by the local gas company or authorized service agent.

The fryer and its individual shut-off valve must be disconnected from the gas supply piping system during any pressure testing of that system at test pressures in excess of 1/2 psig (16 inches W.C.)

The fryer must be isolated from the gas supply piping system by closing its individual manual shut-off valve during any pressure testing of the gas supply piping system at test pressures equal to or less than 1/2 psig (16 inches W.C.)

FOR FRYERS EQUIPPED WITH FRYMASTER COMPUTERS

This equipment generates and uses radio frequency energy. If it is not installed and used properly, it may cause interference to radio and television reception. It has been tested and found to comply with the limits of a Class B computing device in accordance with the specifications in Subpart J of Part 155 of FCC Rules, which are designed to provide reasonable protection against such interference in a residential installation. However, there is no guarantee that interference will not occur in a particular installation. If this equipment does cause interference to radio or television reception, the user is encouraged to correct the interference by one of the following procedures:

1. Reorient the receiving antenna of the receiver.
2. Relocate the computer with respect to the receiver.

3. Move the computer away from the receiver.
4. Plug the computer into a different outlet so that the computer and receiver are on different branch circuits.

If necessary, the user should consult the dealer or an experienced radio and television technician for additional suggestions.

The user may find the following booklet prepared by the Federal Communications Commission helpful: "How to Identify and Resolve Radio-TV Interference Problems". This booklet is available from the U. S. Government Printing Office, Washington, DC 20402, Stock No. 004-000-00345-4.

AFTER FRYER(S) HAVE BEEN INSTALLED AT FRYING STATION:

1. Close fryer drain valve(s) and fill frypot with water up to OIL-LEVEL line at rear of frypot. See BOIL-OUT INSTRUCTIONS in Section 4.
2. Boil out frypot(s).
3. Drain, clean, and fill frypot(s) with shortening. See FILLING WITH COOKING MEDIUM, Section 4.

4. OPERATING INSTRUCTIONS

WARNING

When fryers are in use, fryer restraint chains/cables must be installed in order to prevent the fryer from tipping and splashing hot liquid. Hot shortening causes severe burns. Do not attempt to move a fryer when the frypot is full. Drain frypot completely before moving fryer.

BOILING OUT THE FRYPOT

Clean frypot(s) and tubes as follows before filling with shortening:

1. Before switching the fryer(s) ON, close the frypot drain valve(s); fill empty frypot with mixture of cold water and cleaning solution similar to FRYMASTER FRYER "N" GRIDDLE CLEANER. Follow instructions on bottle when mixing.

2. Depress fryer ON/OFF SWITCH.
3. Program computer for BOIL OPERATION as outlined in PROGRAMMING INSTRUCTIONS, Section 9.
4. Simmer the solution for 45 minutes to one hour. To remove deposits, scrub the sides of the frypot and the tubes with a long-handle, natural-bristle brush, being careful not to disturb the temperature sensing probe and the high-limit thermostat. Do not allow water level to decrease below oil-level line in frypot during boil-out operation.

CAUTION:

NEVER leave the fryer unattended during the boil-out procedure. In the event the boil-out solution should foam up and overflow, press ON/OFF switch to the OFF position.

5. Switch the fryer ON/OFF SWITCH(ES) OFF and allow solution to cool.
6. Add two gallons of water. Drain out the solution and clean the frypot(s) thoroughly.
7. Refill the frypot(s) with clean water. Rinse the frypot(s) twice, drain, and wipe down with a clean dish towel.

CAUTION:

ALL DROPLETS OF WATER MUST BE REMOVED FROM FRYPOT BEFORE FILLING WITH SHORTENING.

NOTE: It is recommended that the boil-out procedure be performed at least once a week to prolong the life of the frypot.

8. The fryer(s) are now ready to fill with shortening.

FILLING WITH COOKING MEDIUM

WARNING

DO NOT melt solid shortening in fryer unless shortening is packed firmly below, between, and above heat tubes or operate fryer if the oil is not up to the oil-level mark in the frypot. Failure to do this may damage the frypot and void the warranty.

LIQUID COOKING OIL

1. Close the drain valve completely and remove the tube screen.
2. Fill frypot to about one (1) inch below the oil fill line when using a liquid cooking oil. This will allow for expansion of the hot cooking oil. The capacity of the frypot is 75 pounds.
3. Turn fryer on by pressing the ON/OFF switch on the computer — left switch for left fryer, right switch for right fryer.

SOLID SHORTENING

1. Close the drain valve completely and remove the tube screen.
2. It is recommended that solid shortening be premelted on another appliance. If you cannot premelt the shortening, pack it into the frypot thoroughly (under, between, and over the tubes) taking care to avoid bending the temperature sensing probe or the high-limit thermostat.

WARNING

Do not leave any air spaces around burner tubes. This can create "hot spots" which may scorch the solid shortening and cause a fire.

3. Turn the fryer ON. The computer will automatically go into the melt cycle. The letters "CYCL" will appear in the display. This will continue until the shortening reaches 180°F (82°C). At that time, the display will read "LO" meaning the temperature is lower than the programmed cooking temperature. The fryer will continue to heat until the preset cooking temperature is reached and "----" (four dashes) show in the display.
4. Replace the basket support racks or crumb screens. You are now ready to begin cooking.

LIGHTING INSTRUCTIONS - TUBE FRYER

Frypot must be filled before lighting. See **BOILING OUT THE FRYPOT**, and **FILLING WITH COOKING MEDIUM** this section.

1. Press fryer power ON/OFF switch to OFF position.
2. Turn gas valve knob (located behind fryer door) to OFF position. Wait five (5) minutes before proceeding.
3. Turn gas valve knob (located behind fryer door) to ON position.
4. Press fryer power ON/OFF switch to ON and program computer for normal cooking temperature (see Computer Programming Instructions, Section 9). Burners will now operate in a MELT-CYCLE MODE until the shortening reaches 180°F (83°C). It will then automatically switch to normal operation. After the shortening has melted and reached frying temperature, computer programmed temperature can be checked by referring to Computer Operating Instructions, Section 8.
5. If burner fails to light, press ON/OFF Switch OFF and wait 60 seconds and repeat above steps.

ACCESSING FRYERS FOR SERVICING

WARNING

Moving a fryer filled with hot shortening may cause splattering of the hot shortening. Extreme care must be exercised. It is recommended that the operator or servicer follow the draining instructions in Section 6 of this manual before attempting to relocate the fryer.

1. Disconnect quick-disconnect gas hose and power cord.
2. Remove restraining devices typically applied to the bottom or back of fryer.
3. Relocate fryer so that access can be obtained to perform necessary maintenance.
4. After servicing has been completed, reconnect quick-disconnect gas hose and power cord; and attach restraining devices.

SHUTTING FRYER(S) OFF FOR SHORT PERIODS

1. Press the ON/OFF key to OFF on the side corresponding to the fryer.
2. Place the frypot cover in place.

SHUTTING FRYER(S) OFF WHEN CLOSING THE STORE

1. Press the ON/OFF key to OFF on the side corresponding to each fryer.
2. Turn the automatic gas valve knob clockwise to OFF position on each fryer.
3. Turn off the manual gas cut-off valve located in the gas supply line under the left-hand fryer.

HELPFUL TIPS ON USING YOUR FRYER

1. The worst enemies of shortening are light, heat, air, and salt. Thus, its life can materially be lengthened by keeping the fryer covered when not in use, frying at the lowest temperatures, and by reducing the temperatures during stand-by periods.
2. A common habit which is harmful to shortening is that of salting foods in baskets over the frypot. Also, if food is fried ahead and stored over the frypot to keep hot, as is often done, it will rapidly lose its crispness and will taste greasy.
3. The fryer burner may require several minutes to light if the connecting gas line has not been purged of air; therefore, the cycling of the ignition module and ignition voltage arcing at the ignitor is normal.

5. VENTILATION AND CLEARANCE

One of the important considerations is ventilation. The fryer must be installed so that products of combustion are removed efficiently, and so that the kitchen ventilation system does not produce drafts that interfere with proper burner operation. The fryer flue opening must

not be placed close to the intake of the exhaust fan.

The fryer must never have its flue extended in a "chimney" fashion. This changes the combustion characteristics of the fryer. This will cause the fryer to be slow to recover, frequently cause delayed ignition, and sometimes cause pilot outage.

Many operators do not realize that the finest ventilation system will break down when it is not maintained properly. The duct system, the hood, and the filter bank must be cleaned on a regular basis and kept free of grease. Adequate make-up air in the area must be provided to compensate for air removed by vent hood and exhaust fans for proper operation of gas-fired equipment.

Adequate distances must be maintained from the flue outlet of the fryer to the lower edge of the filter bank. Filters should never be installed in the horizontal position. They should be installed at an angle of 45° and a drip tray should be located beneath the lowest edge of the filter. NFPA Standard No. 96 states that, "A minimum distance of 18" should be maintained between the flue outlet and the lower edge of the grease filter."

A minimum of 24 inches should be provided at the front of the unit for servicing and proper operation. Air for combustion enters the unit below the cabinet at the base. Do not place anything around the base or under the fryer. Information on construction and installation of ventilating hoods can be found in the NFPA Standard above. A copy of this standard may be obtained from the National Fire Protection Association, Battery March Park, Quincy, Mass. 02269

THE APPLIANCE AREA MUST BE KEPT FREE AND CLEAR OF COMBUSTIBLES.

6. DRAINING AND FILTERING INSTRUCTIONS

The draining and filtering of shortening must be accomplished with care to avoid the possibility of a burn resulting from careless handling.

PREPARING THE FILTER UNIT FOR USE:

1. Turn the fryer off. (See Section 4.)
2. Remove the filter unit from the cabinet.
3. Remove the crumb tray and the filter paper hold-down ring.

NOTE: Be sure the inside of the pan is free of all food particles that could prevent the paper from sealing against the bottom of the pan.

4. Position the filter paper support screen in the pan with the 90° lip down and the "THIS SIDE UP" tab on top.

NOTE: Operating the filter unit without filter paper or with torn paper will cause damage to the filter pump.

5. Position the filter paper on top of the support screen with the edges evenly distributed.
6. Insert the paper hold-down ring and push down firmly to seat paper and ring properly. Sprinkle one (1) cup of filter powder over the filter paper. Replace the crumb tray in the filter pan.
7. Roll the filter back into the cabinet, making sure it is positioned all the way to the back of the cabinet. The green light on the filter panel will come on when the filter is in place. You are now ready to filter.

OPERATION OF THE FILTER UNIT:

WARNING

Do not drain more than one fryer at a time. To do so, will overfill the filter pan.

CAUTION:

Never operate the filter unit unless the fryers have been brought up to cooking temperature.

1. To filter the fryer, turn the fryer power OFF, open the drain valve on the selected fryer, and, if needed, use the "fryer's friend" (steel rod) on the inside of the pot to free any debris from the drain.

CAUTION:

Exercise care when using the "fryer's friend" to prevent damage to the frypot and drain valve.

2. Select the option of your choice for filling — with the wand or from the rear flush on the lower rear section of the frypot.

TO FILL WITH THE WAND:

1. Connect the return wand hose to the quick disconnect valve in the center of the fryers.
2. Hold the wand over and pointing towards the frypot you wish to refill.

DANGER: Never point the wand toward yourself or anyone else. Hot shortening can cause severe burns.

3. Open wand valve at quick disconnect to start pump.

NOTE: "T" handle must be pushed in to OFF position to allow wand valve to start pump.

4. If using solid shortening, allow the pump to run an additional five (5) to ten (10) seconds after the shortening stops coming out to clear the line and to prevent the shortening from solidifying and clogging the hose or pump assembly.
5. Close the drain valve after washing down the frypot with the wand and fill the frypot.

NOTE: If the drain valve is not closed properly, the computer will sound an alarm continuously. To cancel this alarm, turn the computer off, close the drain valve completely, and turn the computer back on.

6. Close wand valve at quick disconnect to stop pump.

TO FILL WITH THE REAR FLUSH:

1. To engage the rear-flush system, pull the "T" handle by the right drain pipe for the right frypot or the "T" handle by the left drain pipe for the left frypot. This activates the pump and opens the rear-flush valve.

NOTE: Wand valve must be turned OFF to allow "T" handle to start pump.

2. Open the fryer drain valve and allow shortening to flush sediment from the frypot into the drain.
3. When frypot is cleared of all sediment, close drain valve and allow frypot to refill.
4. When using solid shortening, allow the pump to run an additional five (5) to ten (10) seconds after the bubbles start coming out to clear the line and to prevent the shortening from solidifying and clogging the hose or pump assembly.
5. Push the "T" handle to disengage the pump and close the rear flush system.

CHANGING THE FILTER PAPER:

NOTE: Allow filter pan to cool completely before attempting to change the paper.

NOTE: It is recommended that the filter paper be changed each time shortening is filtered.

1. Remove the filter pan from the cabinet.
2. Remove and clean crumb tray.
3. Remove the filter paper hold-down ring from the filter pan.
4. Remove and discard the used filter paper.
5. Clean all the remaining food particles from the filter pan.

NOTE: The inner pan may be removed from the outer pan for ease of cleaning.

6. Refer to **PREPARING THE FILTER UNIT FOR USE** in this section for the next operation.

7. CARE AND CLEANING OF YOUR FRYER AND FILTER SYSTEM

WARNING

Never operate the fryer without shortening in the frypot.

The shortening should be filtered as often as needed. If a heavy volume of breaded food is fried, it may be necessary to filter often. (See procedure for details.) This will increase the life of the shortening and produce a better tasting product. The best rule to follow is to filter "before you think it is needed."

The frypot and tubes should be cleaned periodically. This operation, combined with the disposal of used shortening, enhances the flavor of the food product. After the fryer has been emptied, close the drain valve.

Fill the frypot to the oil-level line with clean water and the correct amount of boil-out solution, then place the baskets in the solution and bring the frypot to a boil for ten (10) to fifteen (15) minutes. (See the Computer Programming Instructions in Section 9 for instructions on how to program the computer for the boil-out mode.)

Turn the fryer OFF and drain the solution into a suitable container. **DO NOT** drain the solution into the filter pan. Water and the boil-out solution will damage the filter pump, necessitating replacement. Use a stock pot or a bucket.

WARNING

1. **DO NOT** drain boil-out solution into the filter pan.
2. **DO NOT** pump boil-out solution through filter pump. This can cause internal damage.

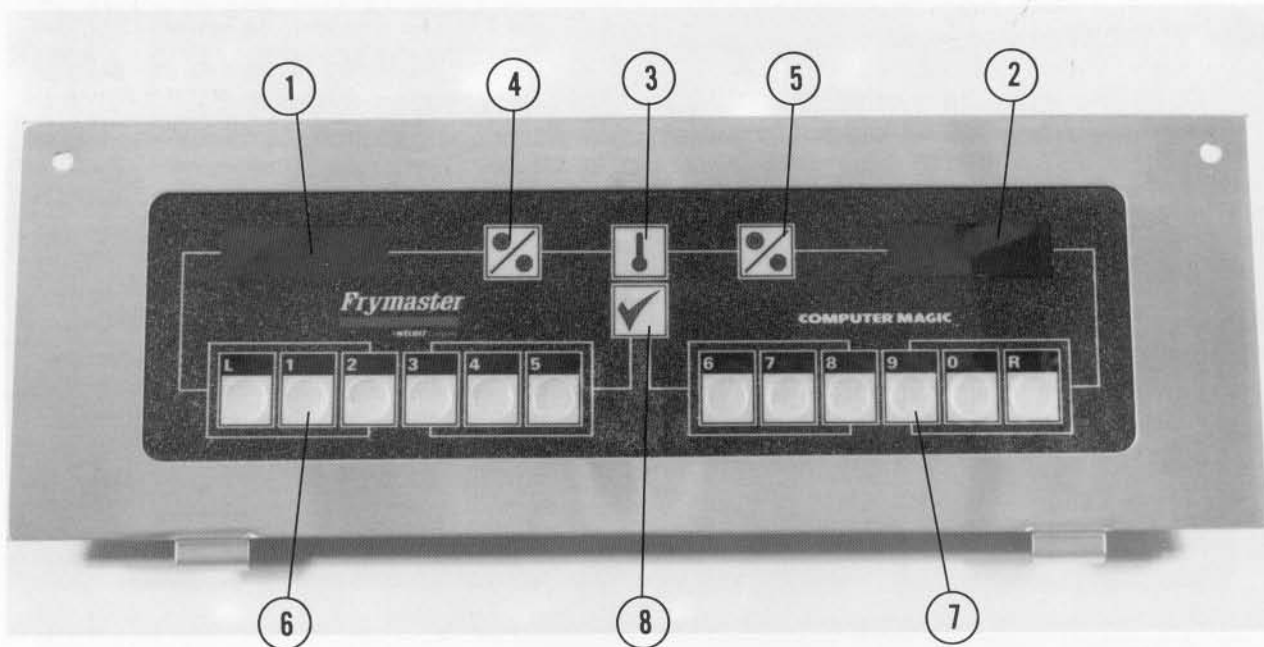

COMPUTER CONTROL PANEL

8. COMPUTER OPERATING INSTRUCTIONS (Refer to Numbers Above)

Item No.

1. Lighted Display — left side display of various functions and operations.
2. Lighted Display — right side display of various functions and operations.
3. Storage and Temperature Check Switch — locks program in computer and/or displays frypot temperature when depressed.
4. ON/OFF Switch — controls on/off for left side frypot.
5. ON/OFF Switch — controls on/off for right side frypot
- 6/7. Product and Coding Switches — enter code for access to computer and programming functions.
8. Programming Switch — used when re-programming the computer memory.

Complies with the limits of a class B computing device pursuant to sub-part J of part 15 of FCC Rules.

WARNING

FRYER MUST BE FILLED WITH OIL, SHORTENING, OR WATER BEFORE TURNING ON COMPUTER.

OPERATING INSTRUCTIONS

- A. Turn the computer on by pressing the ON/OFF SWITCH, Item 4 or 5.
 1. This will turn computer (fryer) on. One of the following will be displayed:
 - a. "CYCL", indicating that the burner is operating in the melt-cycle mode. Fryer will remain in the melt-cycle mode until it reaches 180°F (82°C) or canceled manually. (See B next page.)
 - b. "Hi", indicating that the pot temperature is higher than the set-point temperature.
 - c. "Lo", indicating that the pot temperature is lower than the set point.

- d. "----", indicating that the fryer temperature is in the cooking range. NOTE: For best results, cooking product should not be attempted unless display indicates "----".
- e. "Help", indicating that there has been a heating problem.
- f. "Hot", indicating that the pot temperature is in excess of 385°F (196°C).
- g. "Prob", indicating that the computer has detected a problem in the temperature measuring circuits, including probe.

NOTE: "." decimal point between digits 1 and 2 in either display area indicates that the burner is on.

B. Melt-Cycle-Cancel Feature (built-in computers only).

CAUTION:

Melt cycle should not be canceled if solid shortening is used.

- 1. The computer will display "CYCL" during melt-cycle operation. To cancel melt cycle, depress "R" Switch. "CYCL" will be replaced by "LO". The decimal point between digits 1 and 2 will illuminate indicating that the burners are on.

NOTE: Use "L" Switch for left side pot and "R" Switch for right side pot.

C. Cook-cycle operation is initiated by pressing product switch:

- 1. If "LO" appears when a product switch is depressed, it means that the temperature is at least 40°F (4°C) below set point. The fryers should be checked to assure it is operating properly.
- 2. The display will indicate the previously programmed cook time and begin countdown.
- 3. If shake time is programmed, the operator will be notified of the need to shake the product "X" seconds after the cook cycle has begun (X = amount of time programmed). An alarm will sound, and the display will read "SH_". The blank will be the switch number. If no shake time has been programmed, "SH-" will not

appear during the cook cycle. The alarm is self cancelable.

- 4. At the end of cooking cycle, an alarm will sound; "COOC" will be displayed, and the associated product switch indicator will flash. To cancel the cook alarm, press the appropriate switch.
- 5. At this time, the hold time will be displayed (if programmed greater than 0), and countdown to zero at which time an alarm and "Hd-" will be displayed. The blank will be the switch number. Hold alarm is canceled by pushing PROGRAMMING CHECK SWITCH, Item 8. If display is in use, hold time will count down invisibly until display is free.

CHECKING TEMPERATURE

- A. Check the shortening temperature at any time by pressing STORAGE AND TEMPERATURE CHECK SWITCH, Item 3, once. Check the set point by pressing STORAGE AND TEMPERATURE CHECK SWITCH, Item 3, twice.
- B. During the idle periods when the fryer is on but not in use, "----" should appear in both displays, Item 1 and 2, single frypot computer. "----" will appear in the display of the side that is turned on in a dual pot computer. If not, check actual temperature and set point.
- C. Should you suspect the probe is defective, check shortening temperature with a thermometer to verify that computer readout is reasonably close to your measured reading.

NOTE: The electronic circuitry can be affected adversely by current fluctuations and electrical storms. Should it not function or program properly for no apparent reason, the computer should be reset by unplugging controls power cord and plugging it back in. This could eliminate a service call.

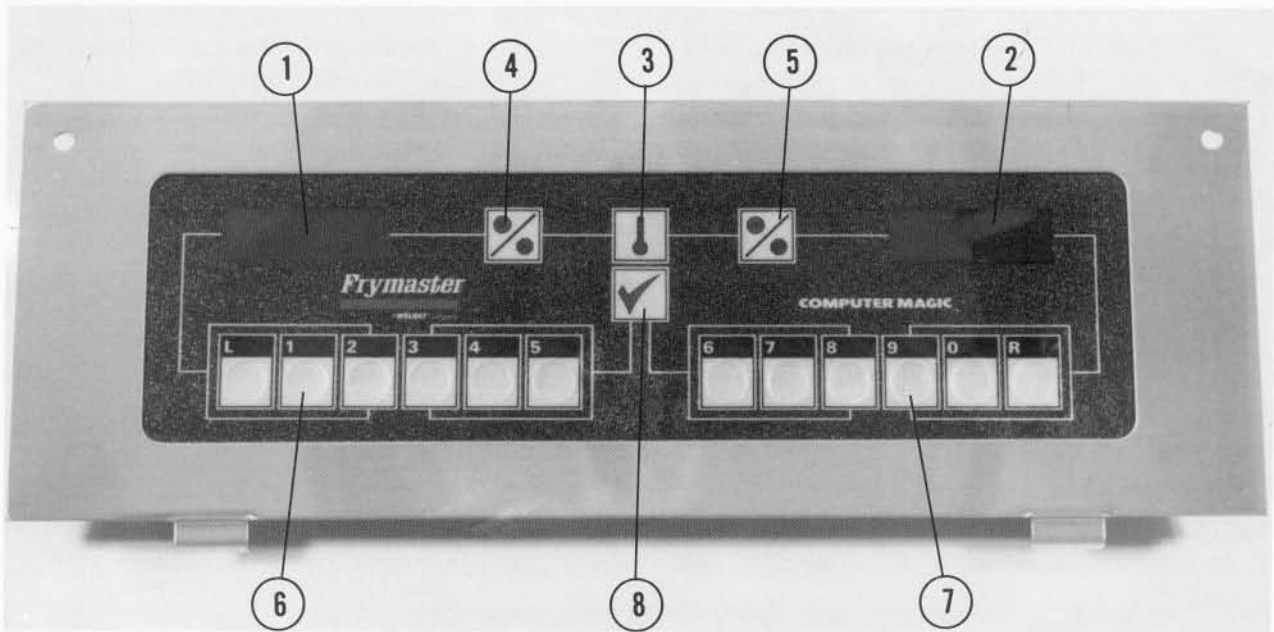

COMPUTER CONTROL PANEL

9. COMPUTER PROGRAMMING INSTRUCTIONS (Refer to Numbers Above)

Item No.

1. Lighted Display — left side display of various functions and operations.
 2. Lighted Display — right side display of various functions and operations.
 3. Storage Switch — locks program in computer.
 4. ON/OFF Switch — controls power supply for left side of dual computer.
 5. ON/OFF Switch — controls power supply for right side of dual computer.
 - 6/7. Product and Coding Switches — enter code for access to computer and programming functions.
 8. Programming Switch — used when re-programming the computer memory.
- WARNING**
 FRYER MUST BE FILLED WITH OIL, SHORTENING, OR WATER BEFORE TURNING ON COMPUTER.
- PROGRAMMING INSTRUCTIONS FOR THE FRYMASTER COMPUTER (TUBE FRYER). PLEASE READ INSTRUCTIONS BEFORE PROGRAMMING COMPUTER**
1. Press either ON/OFF SWITCH, Item 4 or Item 5.
 2. To enter the program modes, press PROGRAMMING SWITCH, Item 8. "CODE" will appear in the left display, Item 1. If you have pressed this switch in error and do not wish to program, simply press PROGRAMMING SWITCH, Item 8 again. NOTE: You cannot program the computer while it is in the cook mode. The computer will flash "BUSY" if cooking is in progress.
 3. Enter Code Number: Press 1,6,5,0 in that sequence on Item 6 and 7. Your program will not be accepted unless these numbers are entered. This prevents an unauthorized person from changing your present instructions.
 4. "SP-r" (SET POINT) will appear in Item 1; this is for setting the cooking temperature for the right pot. The temperature previously selected will be displayed in Item 2. Enter new temperature desired. Press PROGRAMMING SWITCH, Item 8, to lock in temperature setting. If you do

not wish to change the setting, press PROGRAMMING SWITCH, Item 8.

5. "SP-L" (SET POINT) will appear in the left display, Item 1; this is for setting the cooking temperature for the left pot. The temperature previously selected will be displayed in the right display, Item 2. Enter the new temperature desired and press PROGRAMMING SWITCH, Item 8, to lock in temperature setting. If you do not wish to change the setting, press PROGRAMMING SWITCH, Item 8.
6. "SELP" (SELECT PRODUCT) will appear in Item 1. Select buttons "L" through "5", Item 6, for programming the left pot; select buttons "6" through "R", Item 7, for programming the right pot. Press the product switch, Item 6 or 7, to be programmed.
7. "SENS" will appear in Item 1. Sensitivity range is from 1-9; the recommended number to begin with is 4 or 5 (the number you select will be displayed in Item 2 unless you have previously programmed the correct factor to apply for the proper cooking of your product). Press PROGRAMMING SWITCH, Item 8.

NOTE: SENS — Sensitivity is a built-in feature that causes the computer to adjust cooking time to compensate for the drop in shortening temperature when a basket of product is placed into the fryer. Different food products will vary in density, basket-load size, and initial temperature. Food products will also vary in how well cooked a product is required to be. A proper sensitivity setting for each product will assure a high-quality product each time. For example: four ounces of french fries can be programmed to be cooked to the same quality as two and one-half pounds. Some experimenting with the range of 1 to 9 may be required to obtain the desired quality to meet your specifications.

8. "COOC" will now appear in Item 1. If a cooking time has been entered in the program prior to this programming, it will appear in Item 2. If that time is correct, press PROGRAMMING SWITCH, Item 8. If you wish to change that time, enter

the desired numbers. (The new time will be displayed in Item 2.) Press PROGRAMMING SWITCH, Item 8.

9. "SH-" is now displayed in Item 1. If your product requires shaking during the cooking process, set the time by pressing the number of minutes to cook before shaking. This number will appear in Item 2.
Example: Total Cook Time 3:00 minutes
Shake After Cooking 1:00 minute
10. Set the time for 1:00 minute. At the end of the set time, a beeper will sound and the product button will flash for three seconds. If no shake time is required, press "0" and press PROGRAMMING SWITCH, Item 8.
11. "HD-" will now appear in Item 1. Set the time you require for holding the cooked product, 13 seconds to 60 minutes. Press PROGRAMMING SWITCH, Item 8. If you do not wish to use the HOLD time, enter "0" and press PROGRAMMING SWITCH, Item 8.
12. "SELP" will appear in Item 1. If you desire to program more products, return to Step 6. If no more programming is required, lock in program by pressing STORAGE AND TEMPERATURE CHECK SWITCH, Item 3.

BOIL FEATURE

1. Before switching the fryer(s) ON, close the frypot drain valve(s): fill empty frypot with mixture of cold water and FRYMASTER FRYER 'N' GRIDDLE cleaner. Follow instructions when mixing.

NOTE: BOIL MODE WILL NOT TURN ON BOTH SIDES OF COMPUTER. EACH SIDE WILL HAVE TO BE TURNED ON SEPARATELY.

2. To program computer for Boil Feature, press ON/OFF SWITCH, Item 4 or 5.
3. Press PROGRAMMING SWITCH, Item 8. "CODE" will appear in the left display.
4. Enter Code Number: Press 1,6,5,3 in that sequence. The right display will read "BOIL". The temperature is automatically

set for a temperature of 195°F (91°C). The fryer will attain this proper boil temperature and remain there until the ON/OFF SWITCH, Items 4 or 5, is pressed which cancels the boil-out mode. In high-altitude locations, the fryer must be monitored constantly for over-boil conditions. If boil-over conditions occur, turn off fryer immediately, allow to cool, and re-enter boil-out mode to continue the boil-out operation.

FRYER RECOVERY TIME CHECK

1. The computer automatically checks the recovery time each time the pot temperature drops below 250°F (121°C). To check recovery time, press PROGRAMMING SWITCH, Item 8. "CODE" will appear in the left display, Item 1.
2. Enter Code Number: Press 1,6,5,2 in that sequence on Items 6 and 7. The recovery time will appear in both displays, Items 1 and 2, for five seconds.

TEMPERATURE SELECTION MODE — FAHRENHEIT TO CELSIUS

1. To change the computer temperature from Fahrenheit to Celsius or Celsius to Fahrenheit, Press ON/OFF SWITCH, Item 4 or 5.

2. Press the PROGRAM CHECK SWITCH, Item 8. "CODE" will appear in left display, Item 1.
3. Enter Code Number 1,6,5,8 in that sequence on Items 6 and 7. The computer will automatically toggle the temperature from Fahrenheit to Celsius or Celsius to Fahrenheit.
4. Press the TEMPERATURE CHECK SWITCH, Item 3, to display the temperature in the newly-selected mode.

ADDITIONAL HOLD-TIME INSTRUCTIONS

Forcing hold timer to another product button: In the event the same product is being cooked in more than one basket, any product button can be programmed to use the hold timer normally used with a different product button. Example: Program button "3" for 7:00 minutes hold time. Then when programming button "R" for hold time, press address 4. Both "3" and "R" will then use the same hold time of 7:00 minutes. See below for button numbers and their assigned address numbers. Any other button can be programmed to use the same hold time.

BUTTON	L	1	2	3	4	5	6	7	8	9	0	R	
ADDRESS		1	2	3	4	5	6	7	8	9	10	11	12

10. TROUBLESHOOTING GUIDE

WARNING

Inspection, testing and repair of electrical equipment should be performed only by qualified service personnel. The unit should be unplugged when servicing, except when electrical tests are required.

DANGER:
Use extreme care during electrical circuit tests.
Live circuits will be exposed.

NOTE: This guide does not include every possible problem and the cause. However, careful observation of all malfunction indications and logical troubleshooting will help in correcting the problem in a more expedient manner.

NOTE: See SERVICE PROCEDURES to replace fryer components.

PROBLEM (DISLAYED)	PROBABLE CAUSE	CORRECTIVE ACTION
<p>ON/OFF SWITCH ON: Display Shows "HELP", Alarm Sounding, Heat Indicator Cycles ON, All Appropriate Interface Board LED'S ON, Burners Will Not Fire.</p> <p>LED #4 — Right Fryer and/or LED #2 — Left Fryer ON. After a Short Time, Appropriate LED Remains ON; Computer Display Shows "HELP."</p>	A. Drain valve not fully closed.	A. Press ON/OFF switch OFF, close drain valve, press ON/OFF switch ON.
	B. Defective or misadjusted drain valve microswitch.	B. Adjust or replace drain valve switch and repeat step "A" above.
	C. Gas valve knob in OFF position	C. Rotate gas valve knob to ON position and repeat step "A" above.
	D. Hi-limit thermostat defective or stuck open.	D. Check continuity of hi-limit thermostat. Replace if found defective.
	E. Pilot flame adjustment incorrect.	E. Adjust pilot flame at gas valve.
	F. Defective gas valve.	F. Check for 24 VAC across terminals on gas valve when LED #4 comes on. If 24 VAC is present, replace gas valve.
<p>ON/OFF Switch ON: Display Shows "PROB", Alarm Sounding, Heat Indicator OFF.</p>	A. Open or shorted connections in temperature probe circuit.	A. Check continuity or resistance of probe circuit including short to ground. (See INTERFACE BOARD TEST-POINT CHART.)
	1. Open or shorted probe.	1. Replace probe if found defective.
	2. Defective connections in probe circuit.	2. Repair defective connections.
	3. Defective computer.	3. Test computer with Frymaster MTB-310 tester. Replace if found to be defective.
4. Shorted or open probe circuit on interface board.	4. Check probe circuit on interface board. (See INTERFACE BOARD TEST-POINT CHART.) Replace interface board if found defective.	

PROBLEM (DISLAYED)	PROBABLE CAUSE	CORRECTIVE ACTION
(Continued)	5. Loose pin connections in computer connector.	5. Remove connector from back of computer and check for loose or spread pins in connector. Repair as required.
	6. Loose pin connections in main fryer wire harness connectors at front of interface board.	6. Remove main wire harness connectors from front of interface board and check for loose or spread pins. Repair as required.
No Display on Computer, All Interface Board LED'S OFF.	A. No power to fryer.	A. Check fryer power supply. 1. Control power cord unplugged. 2. Reset fryer circuit breaker.
No Display on Computer. Interface Board LED #3 ON LED #6 OFF.	A. Defective 12-volt transformer	A. Check across test points 1 and 3 for 12 VAC on right side of interface board. (See INTERFACE BOARD TEST-POINT CHART.) If 12 VAC is not present, replace 12-volt transformer.
	B. Loose pin connections in wire harness plug.	B. Remove wire harness and check for loose or spread pins. Repair as required.
No Display on Computer. Interface Board LED #3 ON LED #6 ON.	A. Defective computer.	A. Swap computer with another fryer or test with Frymaster MTB-310 tester. Replace if found defective.
	B. Loose connection in computer wire harness connectors.	B. Remove plug from back of computer and check for 12 volts in pins 1 and 3 of plug. If 12 volts is not present, replace wire harness or repair as required.
ON/OFF Switch ON, Display Shows "LO" Heat Indicator Cycles ON and OFF; Burner Does Not Fire. Interface Board LED #3 OFF, LED #6 ON.	A. Defective 24-volt transformer.	A. Check for 24 VAC at test-point 8 and ground on right side of interface board. (See INTERFACE BOARD TEST-POINT CHART.) If 24 VAC is not present, replace 24-volt transformer.
	B. 24-volt trace on interface board burned open.	B. Visually inspect interface board for burned spots and traces. Replace if defective.

PROBLEM (DISPLAYED)	PROBABLE CAUSE	CORRECTIVE ACTION
<p>ON/OFF Switch on, Display Shows "LO"; Heat Indicator Cycles ON and OFF. After a Short Time, Display Shows "HELP"; Burner Does Not Fire.</p> <p>LED #4 — Right Fryer and/or LED #2 — Left Fryer ON. Then After Short Time Appropriate LED's OFF.</p>	A. Defective ignition module.	A. Remove plug cable from ignitor plug and check for strong spark. If no spark, replace module.
	B. Defective ignitor on pilot.	B. Remove ignitor and check for cracked ceramic insulator. Replace if cracked.
	D. Defective ignitor cable. No spark from ignition module to ignitor on pilot.	D. Replace with a known good ignitor cable.
<p>Fryer Slow Coming Out of Melt Cycle.</p>	A. One or more burner tubes not firing due to misalignment. Air shutter out of adjustment.	A. Check alignment of burners to the tubes. Check and adjust air shutter.
	B. Burner gas pressure low.	B. Check and adjust burner gas pressure at gas valve.
	C. Flame not crossing over to all burners. Crossover flame port holes obstructed. Crossover tube out of adjustment.	C. Clean crossover flame port holes. Adjust crossover tube.
	D. One or more burner diffusers collapsed or burned out.	D. Replace diffuser.
<p>Fryer Operating Normally, but Recovery Slow When Cooking Product.</p>	A. Burner gas pressure low.	A. Check and adjust burner gas pressure.
	B. One or more burner tubes not firing due to misalignment. Air shutters out of adjustment.	B. Check alignment of burners with burner tubes. Check and adjust air shutter.
	C. Undersize or clogged burner orifices.	C. Remove orifices and clean. Check for correct size using orifice sizing drills. (See orifice size on fryer serial number plate back of fryer door.)
	D. Burner crossover flame port holes obstructed, crossover tube out of adjustment.	D. Clean crossover flame port holes. Adjust crossover tube.
	E. One or more burner diffusers collapsed or burned out.	E. Replace diffuser.

PROBLEM (DISLAYED)	PROBABLE CAUSE	CORRECTIVE ACTION
<p>ON/OFF Switch ON, Heat Indicator OFF. After Initial Startup, Display Shows "HI, HOT" With Alarm Sounding.</p> <p>NOTE: If fryer is not turned OFF, Heating Will Continue Until Hi-limit Thermostat Trips and Display Will Show "HELP."</p>	A. Heat relay on interface board stuck closed.	A. Unplug relay from interface board and replace with a known good relay.
	B. Defective computer.	B. Swap computer with another fryer or test with Frymaster MTB-310 tester. Replace if found defective.
	C. Heat relay circuit on interface board shorted to ground causing relay to stay energized.	C. Visually check interface board for burned spots. Replace interface board if burned spots are present.
	D. Defective temperature probe.	D. Check resistance of temperature probe (see Inteface Board Test-Point Chart). Replace probe if resistance is incorrect.
<p>ON/OFF Switch On, Display Shows "HELP", Alarm Sounding, Fryer Operating Normally.</p>	A. False alarm.	A. Check for defective components.
	1. Defective computer.	1. Swap computer with another fryer or test computer with MTB-310 tester. Replace if found defective.
	2. Defective lock-out relay.	2. Check for 24 VAC at terminal B of lock-out relay when heat indicator remains on. If 24 VAC is available, replace relay.
	3. Defective interface board.	3. Disconnect alarm wire from both ignition modules. If alarm sound continues, replace interface board.
<p>Computer Will Not Go Into Programming Mode.</p>	A. Computer buttons shorted.	A. Swap computer with another fryer or test with Frymaster MTB-310 tester. Replace if found defective.
<p>ON/OFF Switch On, Display Shows "LO". Heat Indicator Cycles ON and OFF Normally. Burners Will Not Fire.</p> <p>Left or Right Fryer LED #3 ON, LED #6 ON, LED'S #2, and #4, OFF When Heat Indicator Comes On.</p>	A. Defective heat relay on interface board.	A. Unplug heat relay and replace with known good relay.
	B. Defective computer. No VR voltage output on pin 5 of computer connector.	B. Swap computer with another fryer or test with Frymaster MTB-310 tester. Replace if found defective.
	C. Defective pin connections or broken wires in computer wire harness.	C. Swap computer wire harness with another fryer. If fryer operates correctly, replace or repair computer wire harness.

PROBLEM (DISLAYED)	PROBABLE CAUSE	CORRECTIVE ACTION
During Normal Cooking Operation Display Shows "O-HI", "HOT"; Then Displays "PROB" With Alarm Sounding. Oil Temperature is Not Over Heating.	A. Defective temperature probe.	A. Check continuity resistance of temperature probe. (See INTERFACE BOARD TEST-POINT CHART in this manual.) Replace probe if found to be defective.
	B. Loose connections or connector pins in temperature probe circuit causing high resistance.	B. Check pins in connectors of probe circuit and repair as required.
Interface Board LED #4 Will Not Come ON When Heat Indicator is ON. Burners Will Not Fire. LED #4 OFF. After a short time, LED #4 Remains OFF. Display Then Shows "HELP."	A. Defective heat relay right side of interface board.	A. Replace with new relay of same type.
	B. No 24 VAC to interface board.	B. Check for 24 VAC at pin #8 right test points on interface board. If 24 VAC is not present, replace 24V transformer (see Interface Board Test-Point Chart).
Heat Indicator ON, Burners Will Not Fire. Interface Board LED #4 ON For Right Side of Computer; LED #2 for Left Side of Computer.	A. Blown fuse in component box.	A. Check fuse in component box. If fuse is blown, replace with new fuse of same type.
	B. Defective ignition module right fryer.	B. Check for 24 VAC at PV terminal on right ignition module when LED #4 comes on. If 24 VAC is not present, replace right ignition module.
	C. Defective ignition module left fryer.	C. Check for 24 VAC at PV terminal of left module when LED #2 comes on. If 24 VAC is not available, replace left module.
Fryer Operating Normally, but Burner Flame Erratic and/or Yellow in Color. Slow Recovery.	A. Defective regulator in gas valve	A. Replace gas valve.
	B. Low gas pressure.	B. Check and adjust gas pressure.
	C. Air shutters out of adjustment.	C. Check and adjust air shutters.
	D. One or more burner diffusers defective.	D. Replace defective diffusers.
	E. Vent tube on gas valve clogged causing high burner gas pressure.	E. Remove gas valve vent tube and clean with binding wire and reinstall.
Fryer Operating Normally, but Burner Flame Rolling out Front of Burner Tubes.	A. Burners not aligned to tubes.	A. Adjust burner up or down to align with tubes.
	B. Fryer flue restricted or collapsed.	B. Remove restriction from flue or replace collapsed flue.
	C. Insufficient store make-up air.	C. Balance store make-up air.
	D. Exhaust hood air blowing down on fryer flues.	D. Redirect exhaust hood air away from fryers.

TROUBLESHOOTING GUIDE — FILTER SYSTEM

PROBLEM	PROBABLE CAUSE	CORRECTIVE ACTION
Filter Heat Light Does Not Glow.	<ul style="list-style-type: none"> A. Filter pan not in position. B. Loose wire on light. C. Defective light. D. Defective pan heater. E. Contactor block broken or misaligned. F. Defective transformer. G. 3-amp fuse blown for pump and pan heater control circuit. H. Defective filter heat light ballast resistor. 	<ul style="list-style-type: none"> A. Position pan properly. B. Replace wire. C. Replace light. D. Replace heater. E. Replace or realign block. F. Replace transformer. G. Replace blown fuse. If fuse blows again, check for shorted light, pump motor relay, pan heater. Replace the shorted component and install new 3-amp fuse. H. Replace light ballast resistor.
Filter Pan Heater Will Not Heat.	<ul style="list-style-type: none"> A. Pan not in position. B. Contactor block broken or misaligned. C. Pan heater defective. D. Defective transformer. 	<ul style="list-style-type: none"> A. Position pan properly. B. Replace or realign block. C. Replace pan heater. D. Replace transformer.
Pump Will Not Pump.	<ul style="list-style-type: none"> A. Pan not in position. B. Broken o-ring on pump fitting. C. Shortening solidified in pan. D. Pump microswitch broken or not adjusted. E. Pump relay defective. F. Pump motor thermo overload tripped. G. 3-amp fuse blown for pump and pan heater control circuit. H. Filter paper support screen in wrong position. 	<ul style="list-style-type: none"> A. Position pan properly. B. Replace o-ring. C. Allow pan heater to melt shortening. D. Replace or realign switch. E. Replace relay. F. Reset thermo overload. G. Replace blown fuse. If fuse blows again, check for shorted components in pump and heater control circuit. Replace shorted component. H. Position filter paper screen in bottom of pan and place filter paper on top of screen.
Fryer Computer Shows "HELP", Alarm Sounding.	<ul style="list-style-type: none"> A. Drain valve switch not closed. B. Loose wire on drain valve switch. C. Defective drain valve microswitch. D. Microswitch out of adjustment. 	<ul style="list-style-type: none"> A. Close drain valve. B. Replace wire on switch. C. Replace switch on drain valve. D. Adjust switch.

11. PARTS LIST

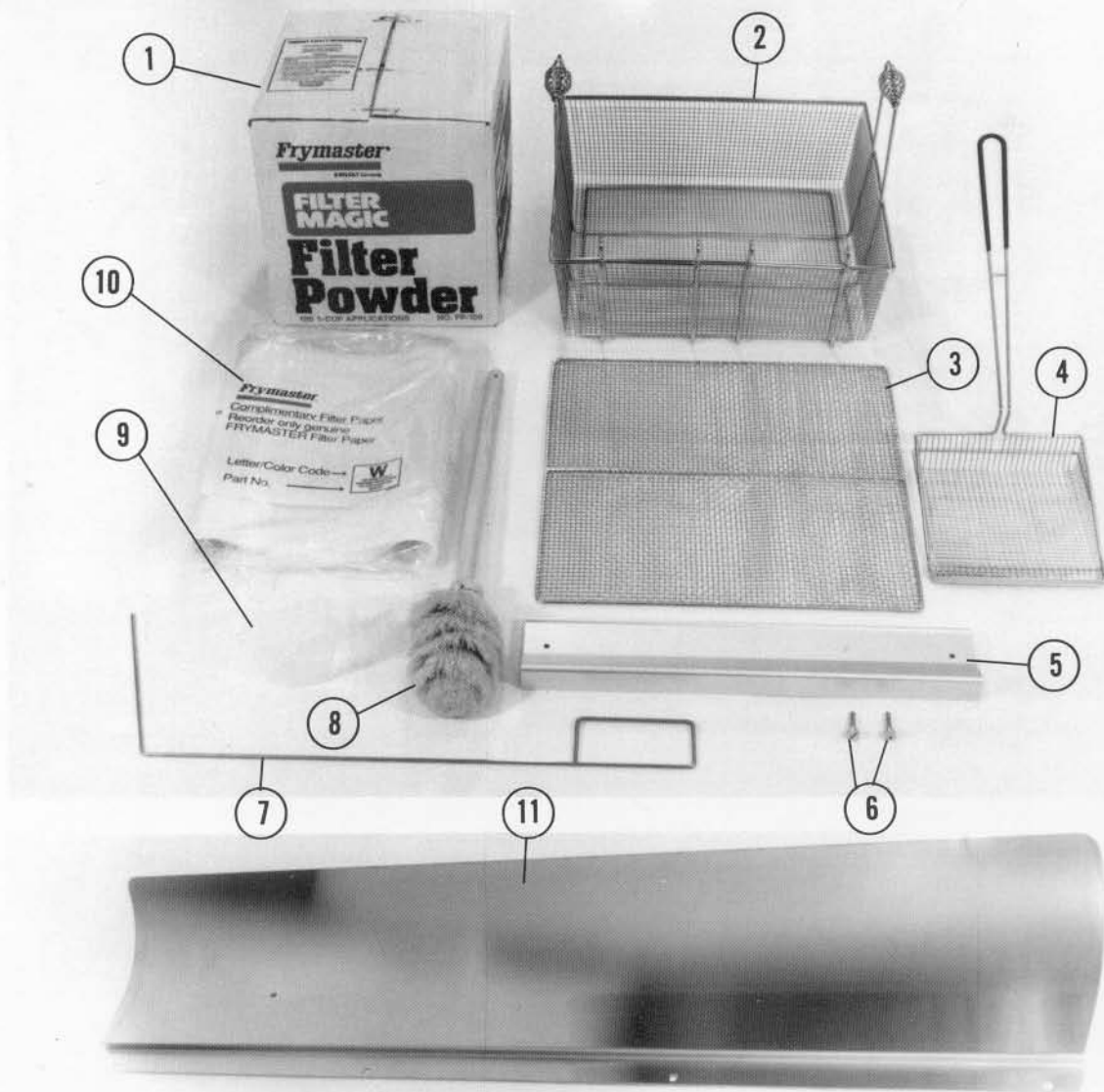

ACCESSORIES

ITEM	PART NO.	DESCRIPTION
1	803-0002	Filter Powder
2	803-0148	Full Basket W/Handles
3	803-0149	Basket Screen
4	803-0059	Scoop, Fish
5	803-0029	Basket Hanger
6	809-0171	Basket Hanger Screw
7	803-0169	Fryer's Friend
8	803-0005	Filter Brush
9	803-0046	Measuring Cup
10	803-0165	Filter Paper
11	910-7110	Flue Deflector
*	806-4530	Frypot Cover
*	826-0993	Frypot Cover Handle

*Not illustrated.

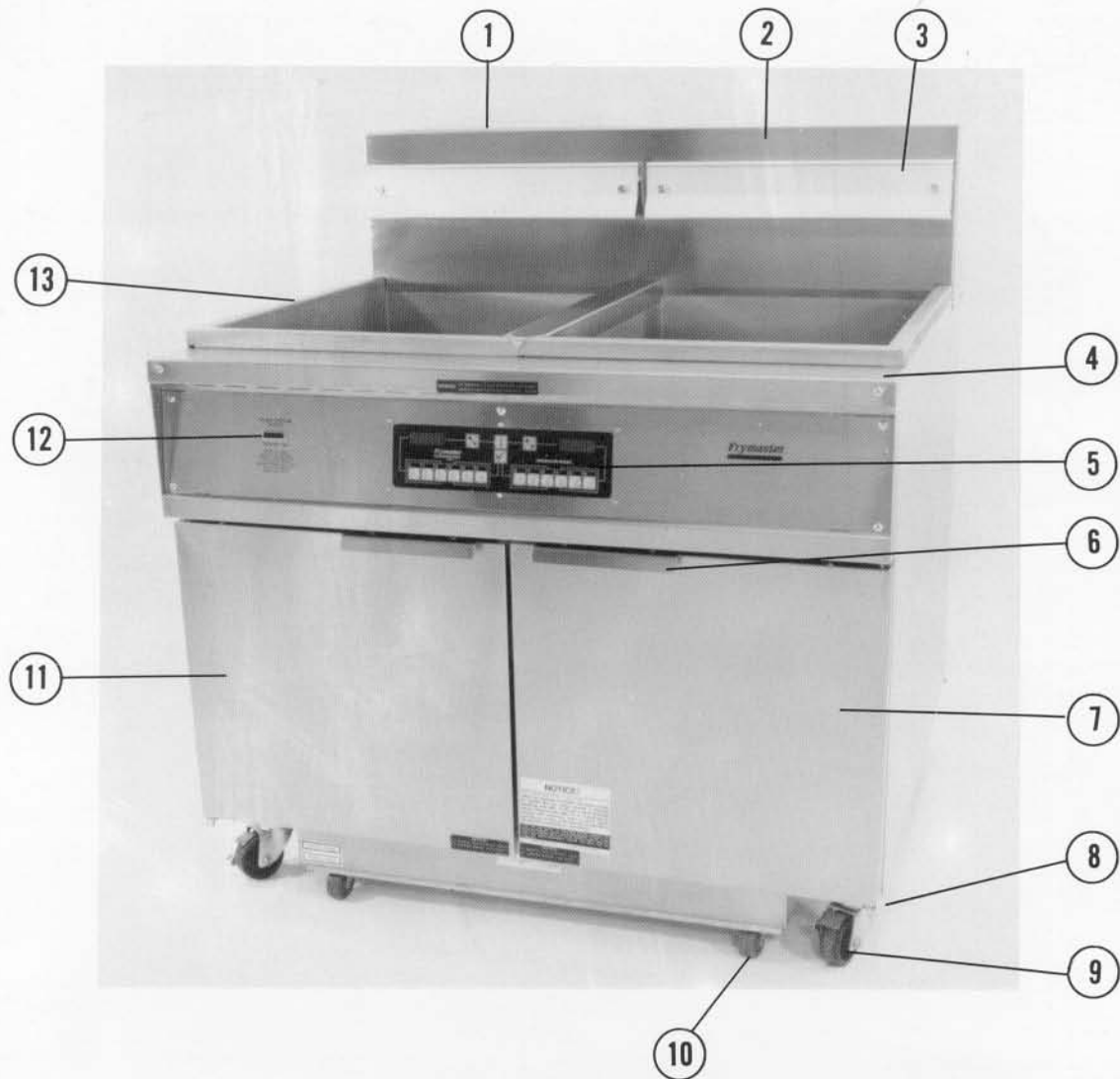

ITEM	PART NO.	DESCRIPTION
1	910-9262	Flue Cap
*	910-7086	Flue Strip
2	803-0029	Basket Hanger
3	809-0171	Screw, Basket Hanger
4	824-0268	Top Cap
5	806-4548	Computer (For 2-battery unit or left side of 3-battery unit.)
5	806-5098	Computer (For right side of 3-battery unit only.)
*	806-3660	Sound Device (Computer)
6	910-3672	Door Handle
7	806-5009SP	Door, Right
8	900-07341	Door Hinge Pin
9	810-0651	Caster, W/Brake (Front)
10	810-0006	Caster, Filter Pan
11	806-5008SP	Door, Left
12	807-1275	Filter Status Light
13	910-7085	Connecting Strip
*	810-0356	Caster, W/O Brake, Rear

*Not illustrated.

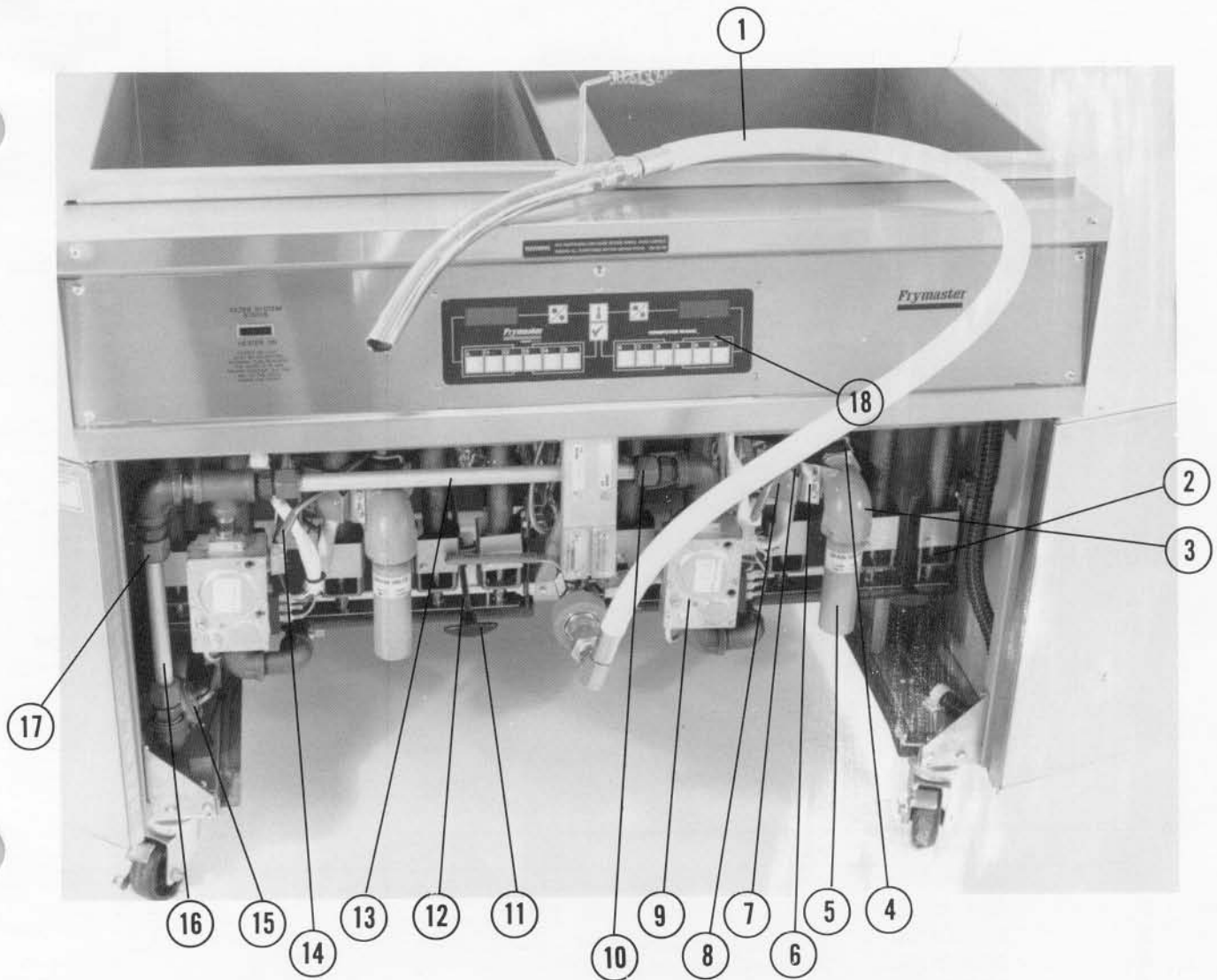

ITEM	PART NO.	DESCRIPTION
1	806-4535	Wand, Filter Hose
2	810-0675	Orifice, 44 Nat (5 per fryer)
2	810-0710	Orifice, 54 LP (5 per fryer)
3	823-1514	Elbow, Drain Switch
4	810-0583	Drain Valve, 1-1/4" Gemini
5	813-0380	Drain Nipple
6	900-1419	Drain Switch Mounting Bracket
7	807-0027	Microswitch
8	900-1420	Drain Switch Cover
9	810-0786	Gas Valve, Nat.
9	810-0787	Gas Valve, LP
10	813-0010	Compression Fitting, 1/2"
11	810-0680	T-handle, Oil Return
12	910-7107	Oil Return Linkage
13	900-4208	Gas Line, Long
14	823-1516	Drain Handle
15	810-0239	Shut-off Valve
16	900-1457	Gas Line, Short
17	813-0205	Compression Fitting, 3/4"
18	806-4548	Computer (For 2-battery unit or left side of 3-battery unit.)
19	810-0487	Male Quick Disconnect Fitting

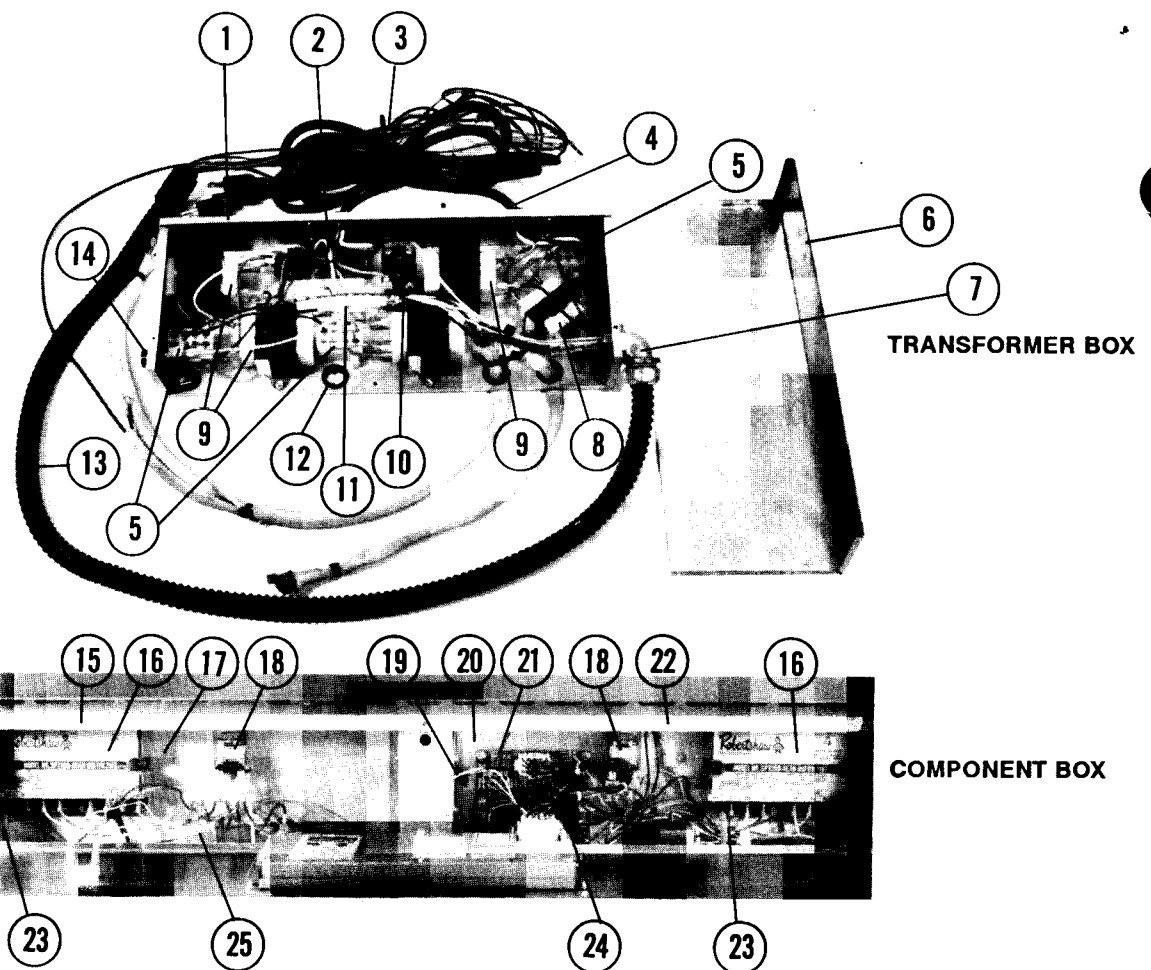

ITEM	PART NO.	DESCRIPTION
1	806-4575	Transformer Box Assembly
2	807-1322	Terminal Block, 12-Pin
3	807-0154	Cord Set, Filter
4	807-0154	Cord Set, Fryer
5	807-0067	Terminal Block, 8-Pin
6	900-4230	Cover, Transformer Box
7	807-1319	Elbow
8	807-0855	Transformer, 12-Volt
9	807-0800	Transformer, 24-Volt
10	807-0012	Relay, Filter Pump
11	806-4358	Resistor
12	810-0045	Bushing
13	812-0829	Plastic Conduit
14	807-1321	Fuse Holder
15	806-4545	Component Box Assembly, Left
16	807-1312	Ignition Module
17	900-4206	Mounting Plate, Left
18	807-1035	Relay, 24V
19	810-0678	Grommet
20	900-4207	Mounting Plate, Right
21	806-4549	Interface Board
22	806-4546	Component Box, Right
*	806-4908	Component Box, Right W/O Rear Flush
23	807-1315	Ignition Cable
24	807-0833	Heat Relay
25	807-1313	Hi-limit Thermostat
*	810-0708	Hi-limit Spring
*	807-0910	Fuse, 3-amp
*	807-1321	Fuse Holder

*Not illustrated.

FRYPOT ASSEMBLY - EXPLODED VIEW

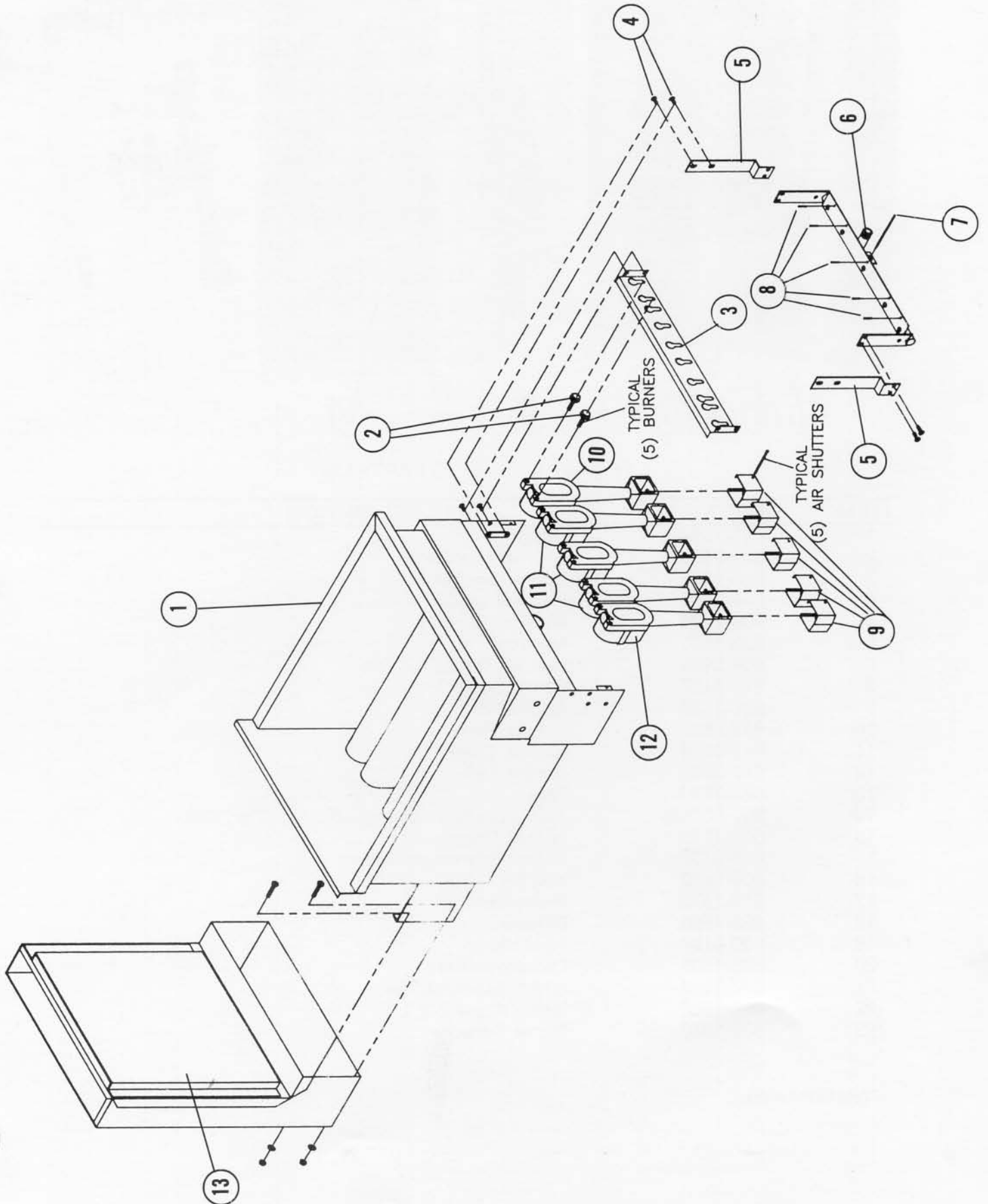

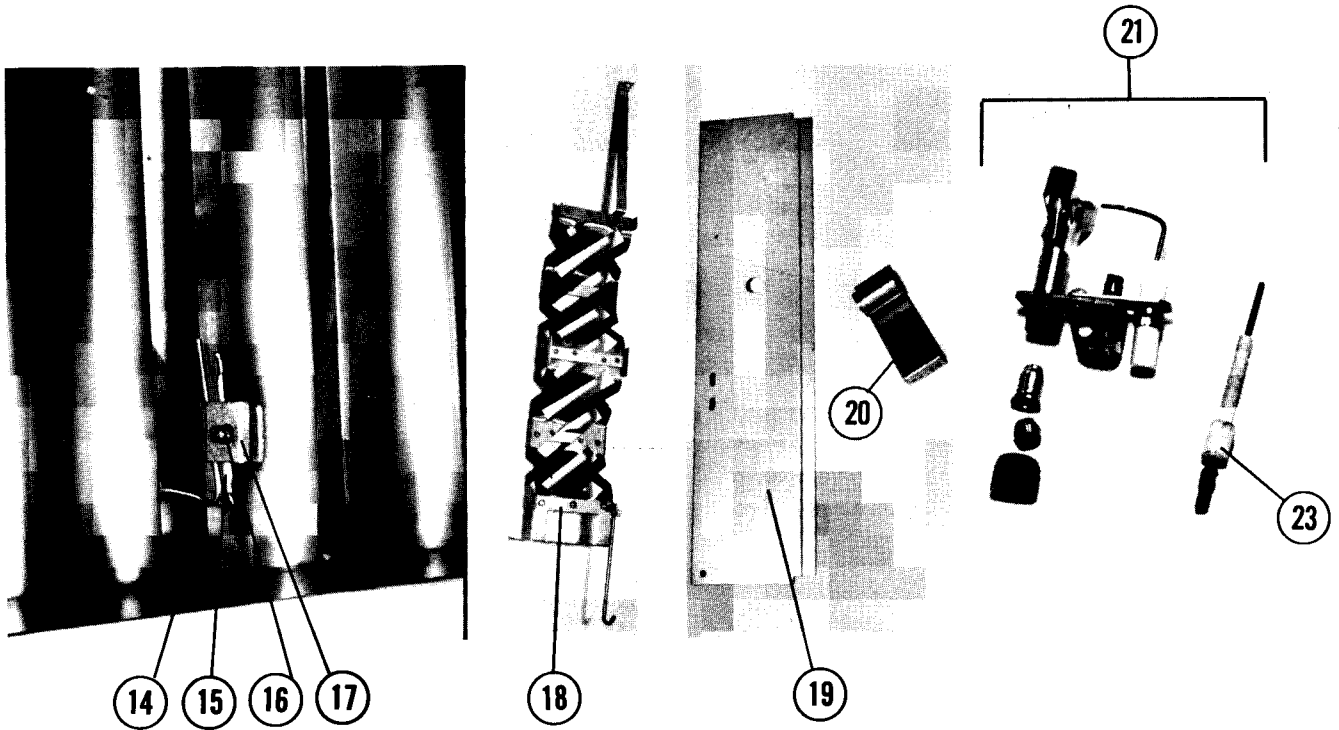

FRYPOT & RELATED PARTS LIST

ITEM	PART NO.	DESCRIPTION
1	823-1566	Frypot
2	809-0459	Washer Head Bolt
3	823-1562	Burner Bracket
4	809-0071	Hex Nut 1/4-20
5	900-1428	Manifold Bracket
6	823-1561	Manifold
7	809-0439	Bolt, All Thread 1/4-20
8	810-0167	Spring Dowel Pin
9	900-1438	Air Shutter
10	812-0837	Burner, Right
11	812-0836	Burner, Center
12	812-0835	Burner, Left
13	823-1670	Flue
14	806-5006SP	Temperature Probe Assembly, Left or Right
15	807-1313	Hi-limit Thermostat
*	810-0708	Hi-limit Thermostat Spring
16	809-0442	Nut, SS 1/4-20
17	910-1573	Probe Retainer
18	823-1505	Diffuser
19	900-4197	Heat Shield
20	823-1531	Crossover Tube
21	807-1311	Ignitor Assembly, Nat.
22	807-1553	Ignitor Assembly, L.P.
23	807-1310	Flame Sensor

*Not illustrated.

FILTER PAN HEATER CONTACT BLOCK ASSEMBLY

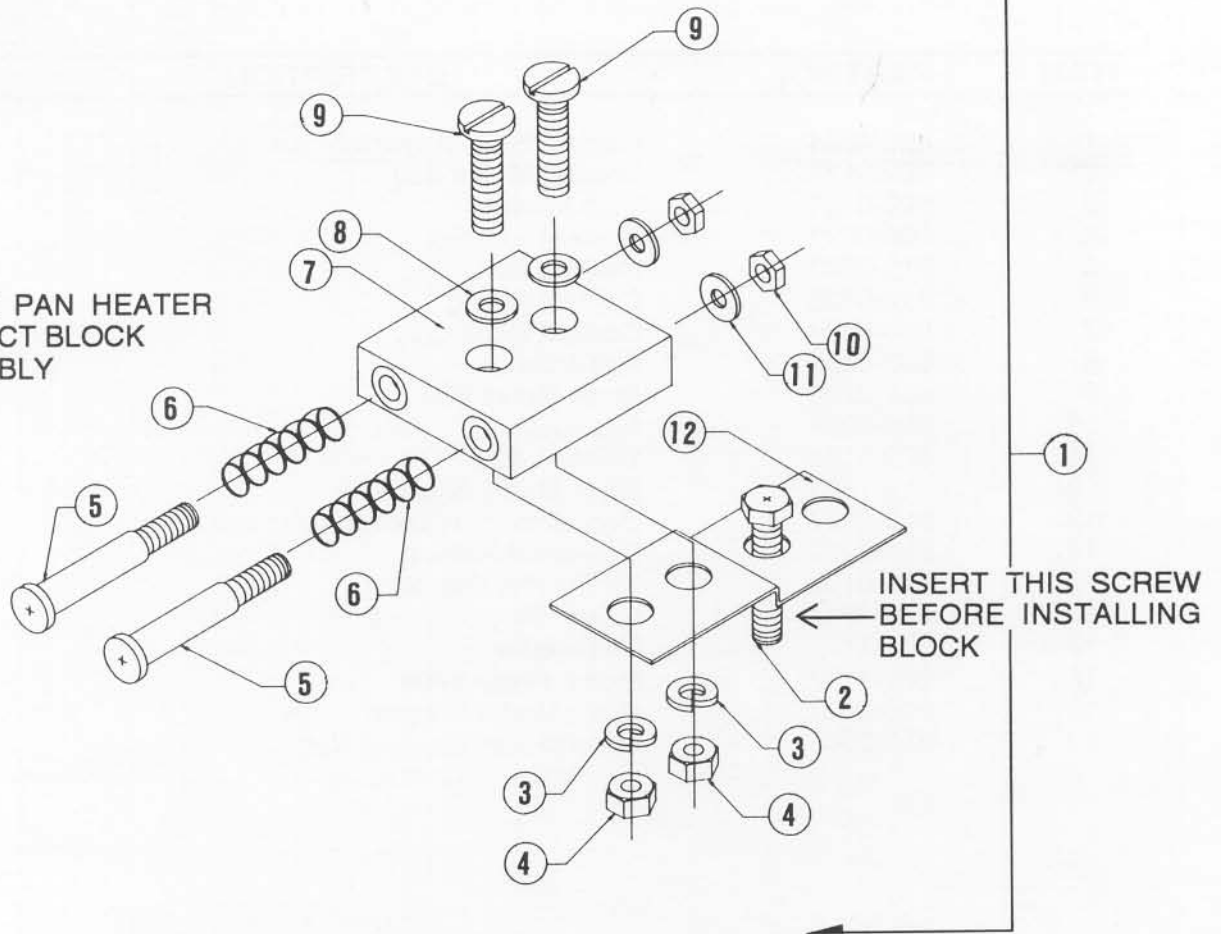

CONTACTOR BLOCK ASSEMBLY

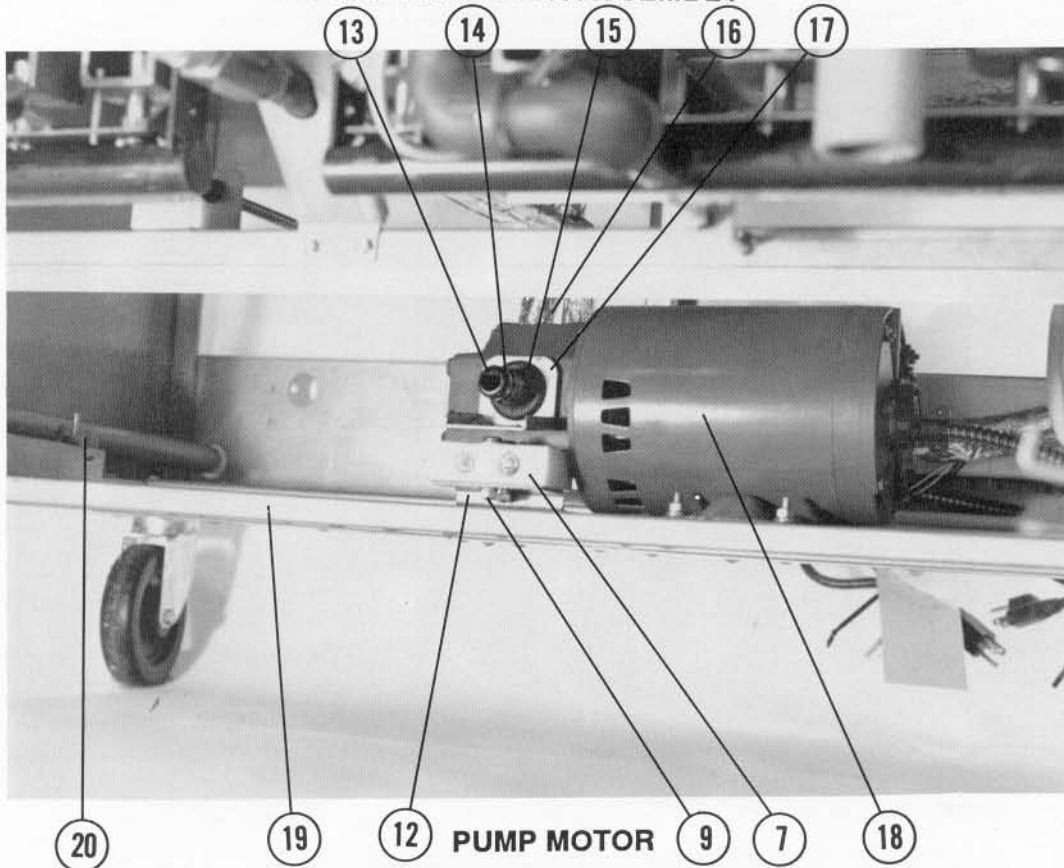

ITEM	PART NO.	DESCRIPTION
1	806-4694	Contact Block Assembly
2	809-0131	Bracket Mount Bolt
3	809-0191	Lock Washer
4	809-0071	Block Mount Nut
5	810-0693	Contact Pin
6	810-0696	Contact Spring
7	810-0694	Contact Block Only
8	809-0435	Flat Washer
9	809-0291	Block Mount Bolt
10	809-0053	Nut 10-32
11	809-0185	Washer, #10
12	910-1521	Block Mount Bracket
13	810-0697	Connector, Oil Pick-up
14	816-0012	O-ring, Oil Pick-up
15	816-0102	Oil Diverter Grommet
16	806-4557	Heater Strip
17	900-1472	Oil Diverter
18	807-1197	Motor, Pump 120V
19	900-7057	Motor Mount Support
20	810-0665	Motor Mount Leveling Nut

OUTER FILTER PAN ASSEMBLY - EXPLODED VIEW

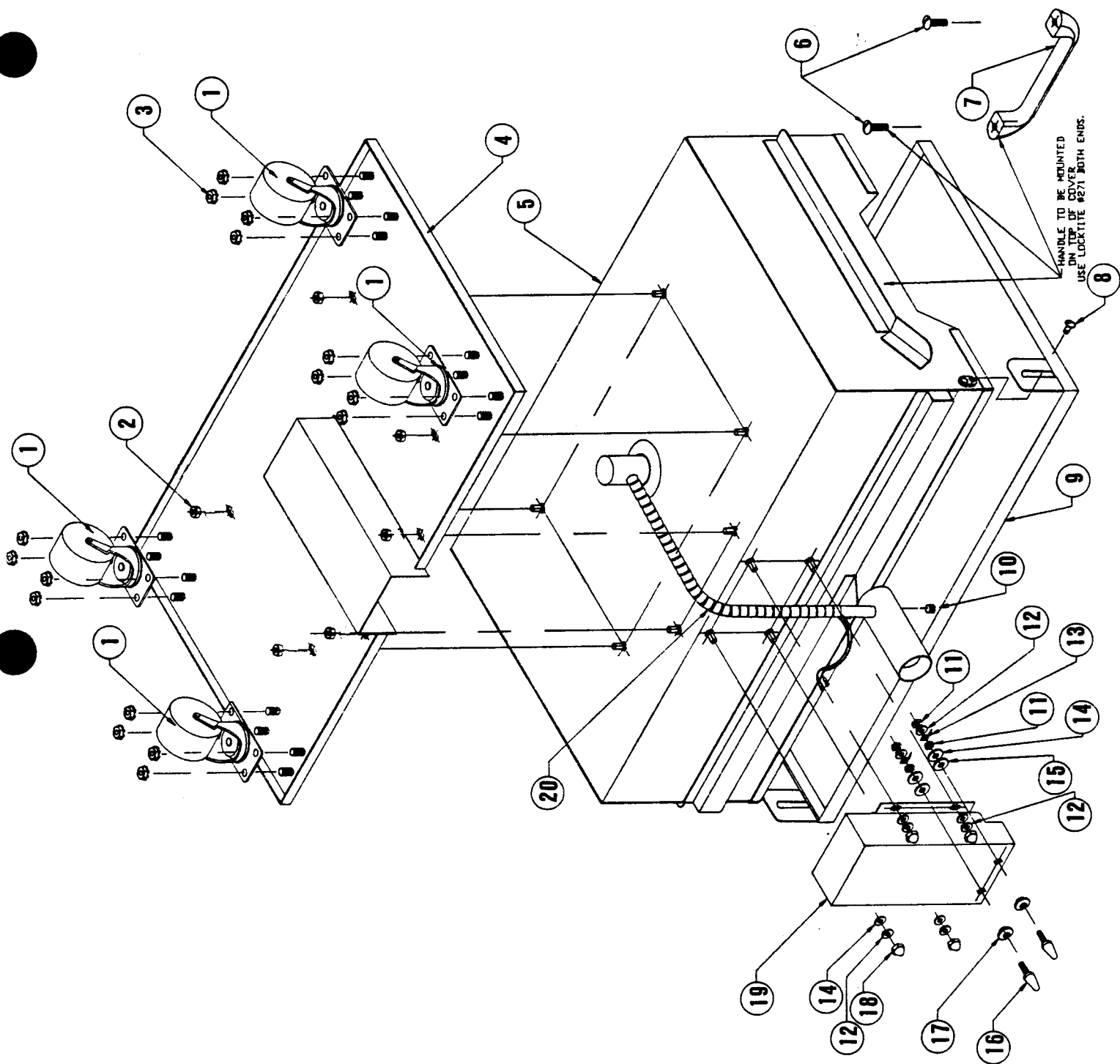

INNER FILTER PAN ASSEMBLY

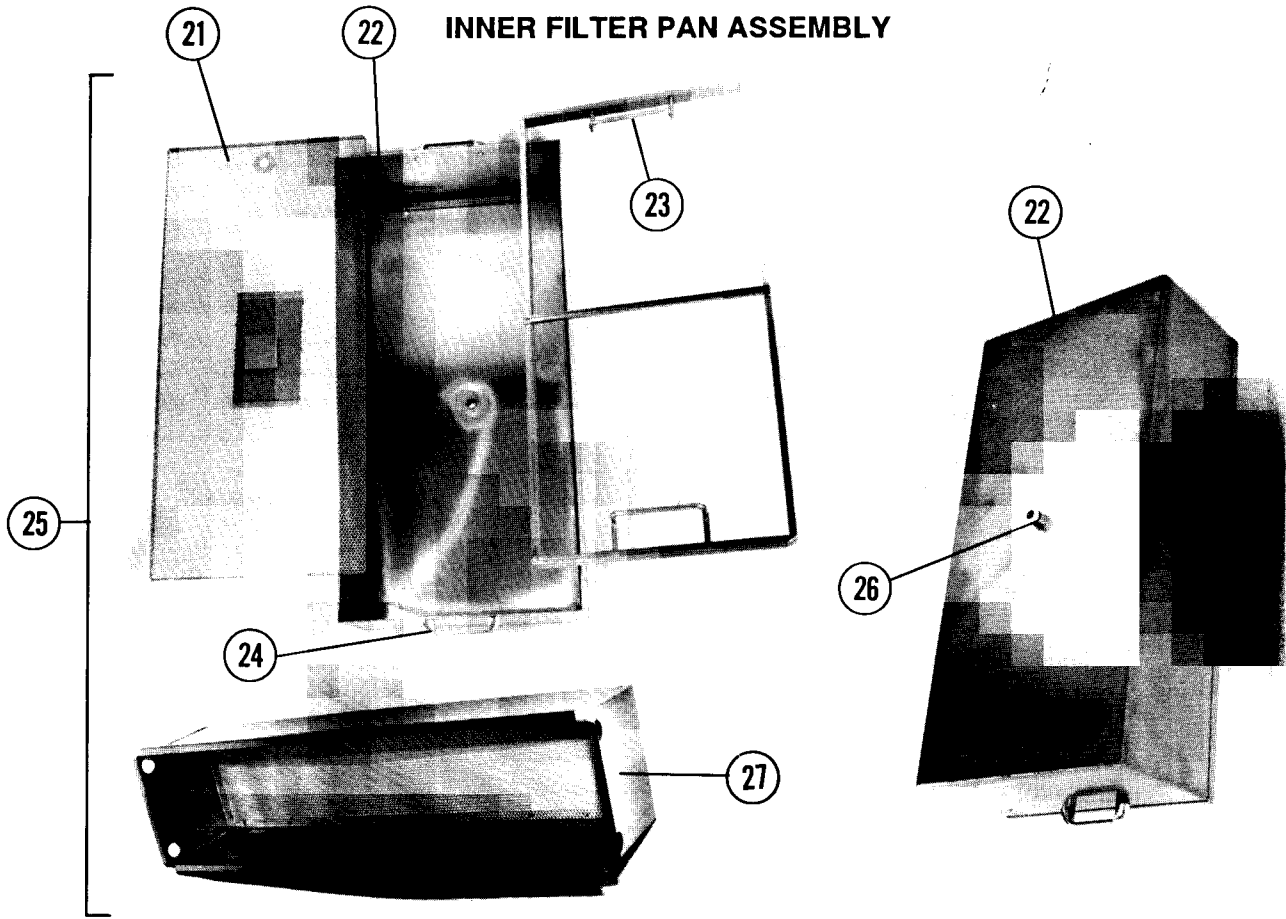

ITEM	PART NO.	DESCRIPTION
1	810-0006	Caster
2	809-0417	Lock Nut
3	809-0256	Keeps Lock Nut
4	823-1475	Filter Pan Base
5	806-4486	Outer Pan Assembly
5	823-1466	Outer Pan Only
6	809-0024	Screw 10-24 X 3/8"
7	810-0180	Handle
8	809-0422	Screw, Shoulder 10-32
9	823-1501	Filter Pan Cover
10	813-0411	Pipe Plug
11	809-0053	Nut 10-32
12	809-0184	Lock Washer
13	807-0037	Terminal Tab
14	809-0185	Flat Washer, #10
15	807-1367	Washer, Flat Non-conductive
16	810-0695	Contact, Heater Pan
17	807-1270	Washer, Shoulder Insert
18	809-0020	Nut, Cap 10-24
19	824-0312	Housing, Tube and Heater
20	806-4373	Pan Heater
21	823-1686	Filter Paper Screen
22	823-1713	Inner Filter Pan Only
23	823-16841	Filter Paper Hold-down Ring
24	810-0180	Handle, Filter Pan
25	806-4854	Inner pan Assembly
26	816-0117	O-ring Filter Pan
27	823-1491	Crumb Screen

12. SERVICE PROCEDURES

Replace Computer

Tools: Phillips Screwdriver

Parts: Computer

1. Remove 5 control panel screws (Fig. 1).
2. Control panel is hinged at bottom and will swing down from the top.

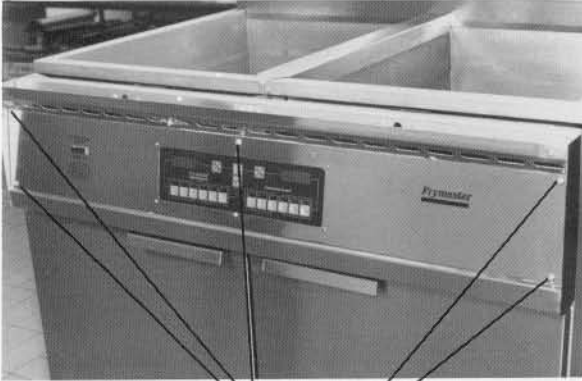

Figure 1

3. Unplug wiring harness and ground wire from back of computer (Fig. 2).

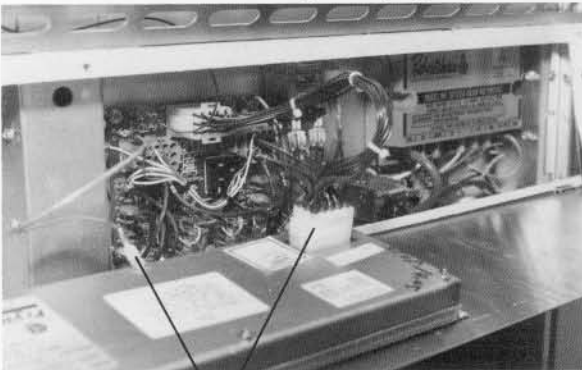

Figure 2

4. Remove 6 screws and nuts securing computer to control panel and remove computer (Fig. 3).

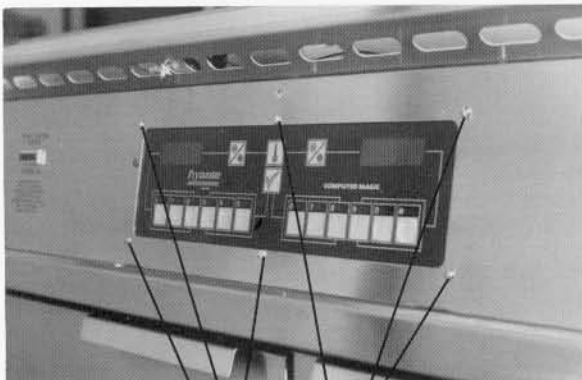

Figure 3

5. Reverse procedures to install new computer.

Replace Hi-limit Thermostat

Tools: Phillips Screwdriver, Adjustable Wrench, Loctite Thread Sealant PST56765

Parts: Hi-limit Control

1. Drain shortening from frypot into suitable container.
2. Remove 5 control panel screws (Fig. 1)
3. Swing control panel down from top.
4. Remove 2 screws securing hi-limit thermostat body to control box (Fig. 4).

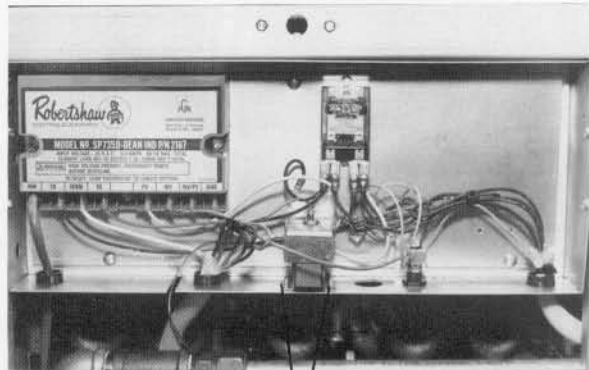

Figure 4

5. Using wrench, remove nut, clip and spring holding hi-limit thermostat bulb to bracket inside pot (Fig. 5).

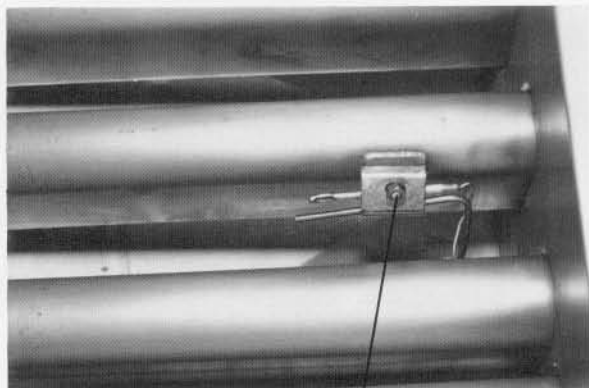

Figure 5

6. Using wrench, remove plug that secures hi-limit thermostat capillary to bottom of frypot (Fig. 6).

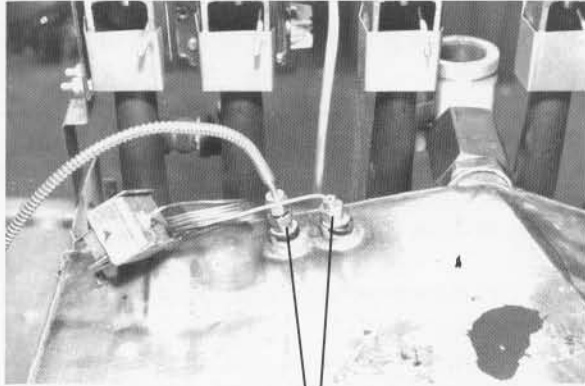

Figure 6

- Reverse above procedures to install new hi-limit thermostat. **NOTE:** Use Loctite PST56765 thread sealant on threads of plug before screwing into fitting on bottom of pot.

Replace Temperature Sensing Probe

Tools: Pin Pusher, Adjustable Wrench,
Parts: Temperature Sensing Probe, Loctite
PST56765

- Drain shortening from frypot into suitable container.
- Remove 5 control panel screws (Fig. 1).
- Swing control panel down from top.
- Remove 12-pin plug containing probe wires from interface board (Fig. 7).
- Using pin pusher, remove probe pins from plug (Fig. 7).



Figure 7

- Remove end of shielded probe cable from control box (Fig. 8).

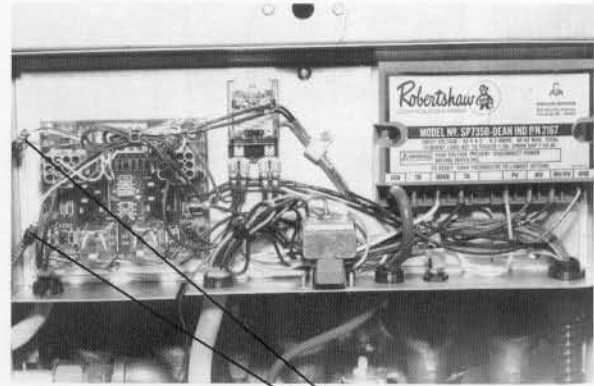

Figure 8

- Using wrench, remove the plug that secures probe cable to bottom of frypot (Fig. 6).
- Reverse above procedures to install new probe. **NOTE:** Use Loctite PST56765 thread sealant on threads of plug before screwing into fitting on bottom of frypot.

Replace Ignitor Module

Tools: Phillips Screwdriver, Nut Driver

- Remove 5 screws from control panel (Fig. 1).
- Swing control panel down from top.
- Remove ignition cable and other wires at bottom of ignitor module (Fig. 9).
- Using nut driver, remove 2 ignitor module mounting screws (Fig. 9).
- Reverse above procedures to install new module.

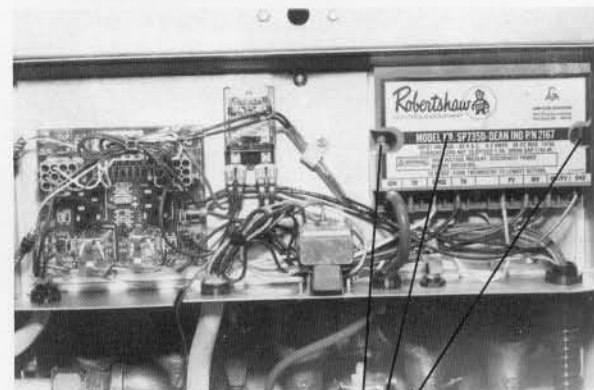

Figure 9

Replace Ignitor

Tools: Adjustable Wrench, Phillips Screwdriver, Nut Driver

Parts: Ignitor

1. Remove high-voltage wire from ignitor (Fig. 10).
2. Remove flame sensor wire from ignitor (Fig. 10).
3. Remove gas line fitting and gas line from ignitor (Fig. 10).
4. Remove mounting screw and nut from ignitor bracket and lower ignitor (Fig. 10).
5. Reverse above procedures to install new ignitor.

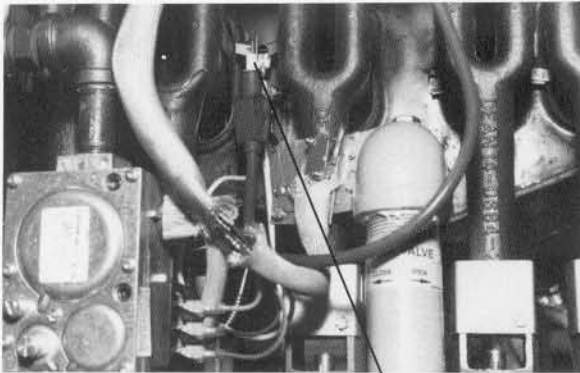

Figure 10

Clean Gas Valve Vent Tube

Tools: Adjustable Wrench, Wire

1. Remove vent tube from gas valve (Fig. 11).
2. To clean out the vent tube, insert a piece of ordinary binding wire (.052 dia.) through the tube to remove any obstructions.
3. Remove the binding wire and blow through the tube.
4. To reinstall the vent tube, reverse procedure.



Figure 11

Replace Gas Valve

Tools: Adjustable Wrench

Parts: Gas Valve

1. Disconnect wires from terminals on valve (Fig. 12).
2. Remove ignitor vent tube fittings and tubing from valve (Fig. 12).
3. Disconnect and remove gas supply lines (Fig. 12).
4. Swing valve and pipe assembly out from top and unscrew gas valve.
5. Reverse above procedure to install new valve. **NOTE:** Use small amount of Loctite PST56765 thread sealant on threads of pipe fittings before installing fittings in valve.



Figure 12

Replace Gas Valve (24-V Supply) Fuse

1. Remove fuse holder cap under component box and remove defective fuse (Fig 13).
2. Replace with new 3-amp fuse of the same type and screw fuse holder cap back in place.

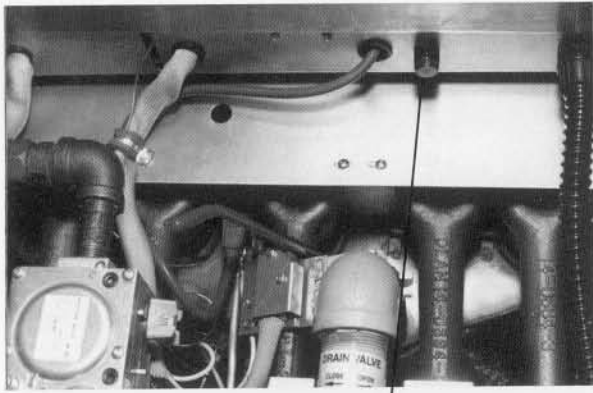

Figure 13

Replace Interface Board

Tools: Phillips Screwdriver, Nut Driver

Parts: Interface Board

1. Remove 5 screws from control panel (Fig. 1).
2. Swing control panel down from top.
3. Disconnect 3 plugs from board (Fig. 14).
4. Unplug 2 relays from board (Fig. 14).
5. Disconnect all wires from board (Fig. 14).
6. Using nut driver, remove 4 nuts at corners of board (Fig. 15).
7. Reverse above procedures to install new board.

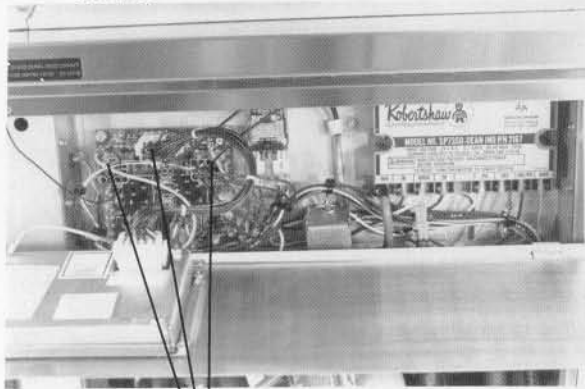

Figure 14

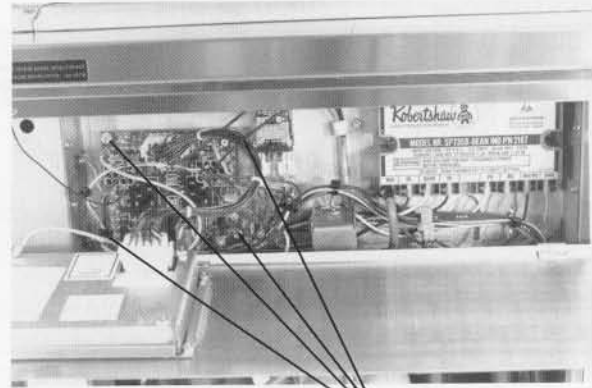

Figure 15

Replace A Single Burner

Tools: Phillips Screwdriver, Nut Driver

Parts: New Burner

1. Remove 2 heat shield retaining screws (Fig. 16).
2. Remove screw from burner air shutter (Fig. 16).

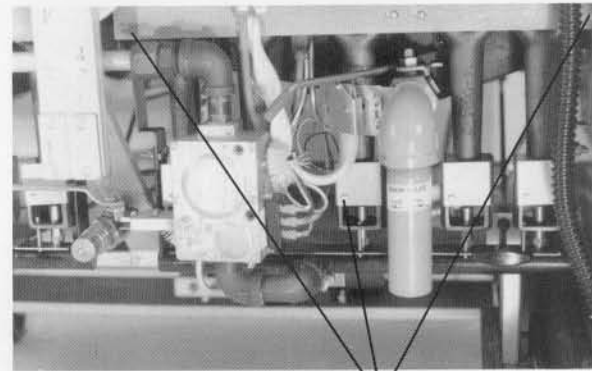

Figure 16

3. Loosen two screws at upper part of burner (Fig. 17).

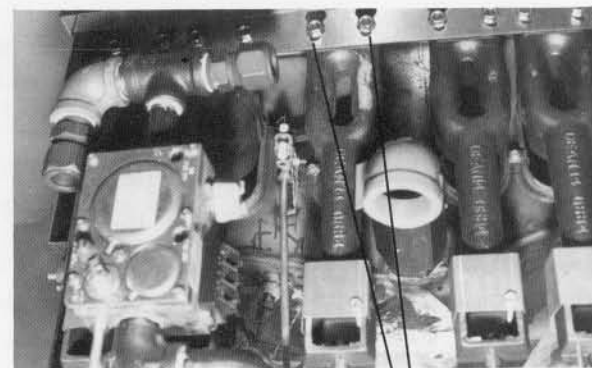

Figure 17

4. Lift up on burners and pull out at bottom.

- Reverse above procedures to install new burner. **NOTE:** Make sure new burner is correct part number. The two outside burners have different pin-hole locations than center burners.

Replace Frypot

Tools: Phillips Screwdriver, Pin Pusher, Nut Driver, Adjustable Wrench
Parts: Frypot, Loctite PST 56765 Thread Sealant

- Remove connecting strip (Fig. 18).
- Remove top cap (Fig. 13).

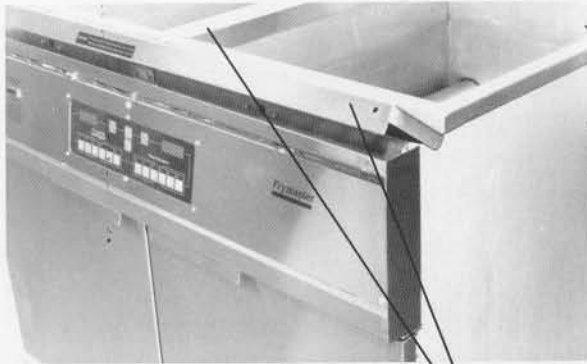

Figure 18

- Remove flue cap (Fig. 19).

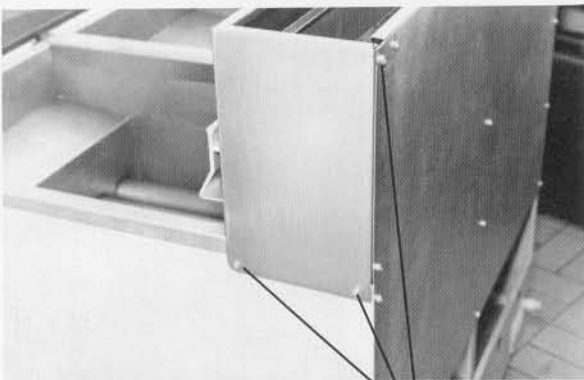

Figure 19

- Remove 5 control panel screws (Fig. 20).
- Control panel is hinged at bottom and will swing down from the top.

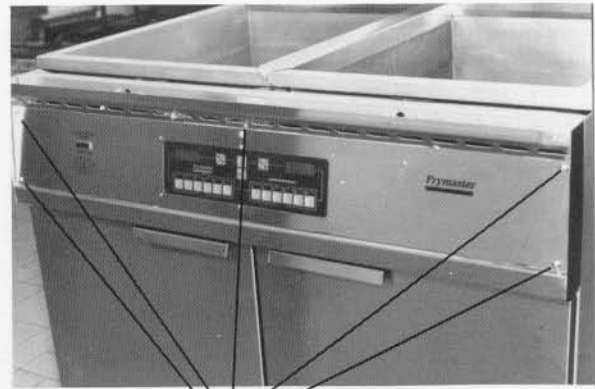

Figure 20

- Unplug wiring harness and ground wire on back of computer (Fig. 21).
- Remove panel from fryer.



Figure 21

- Remove hi-limit thermostat body from component box (Fig. 22).

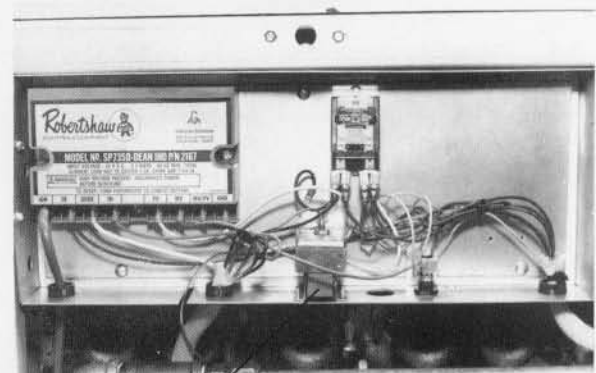

Figure 22

- Unplug 12-pin connector from interface board (Fig. 23).
- Remove pins for probe from 12-pin connector.



Figure 23

11. Remove probe wire cable from component box.
12. Remove gas line from gas valve (Fig. 24).
13. Disconnect wire assembly from top of gas valve (Fig. 24).

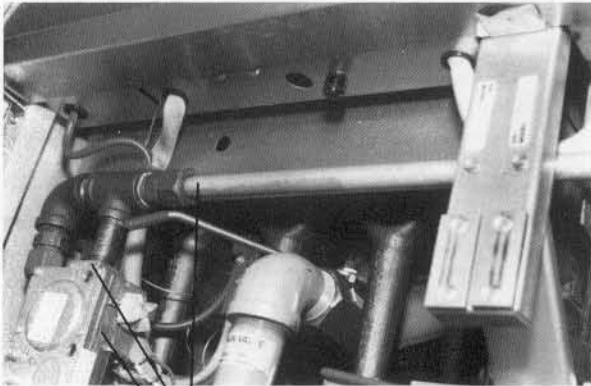

Figure 24

14. Remove mounting screw under gas manifold (Fig. 25).

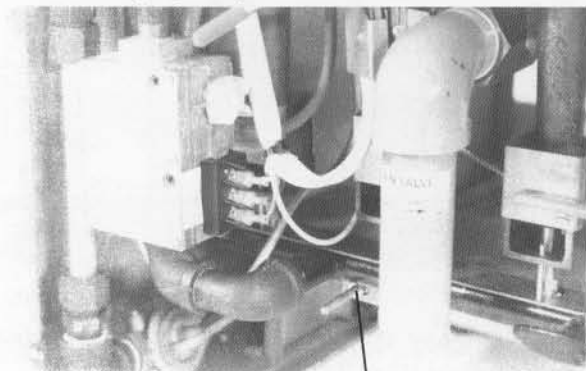

Figure 25

15. Remove drain valve handle (Fig. 26).
16. Remove safety drain switch from drain elbow bracket (Fig. 26).

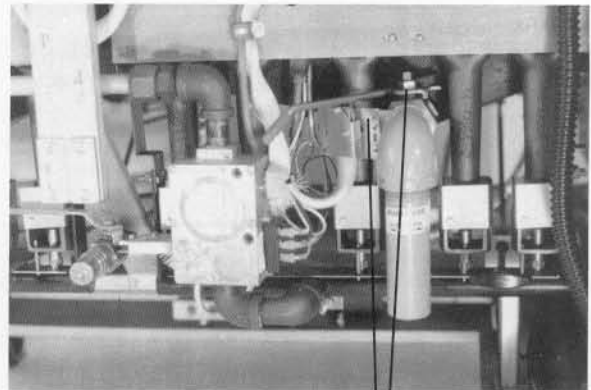

Figure 26

17. Remove high-voltage lead and flame sensor wire from ignitor (Fig. 27).

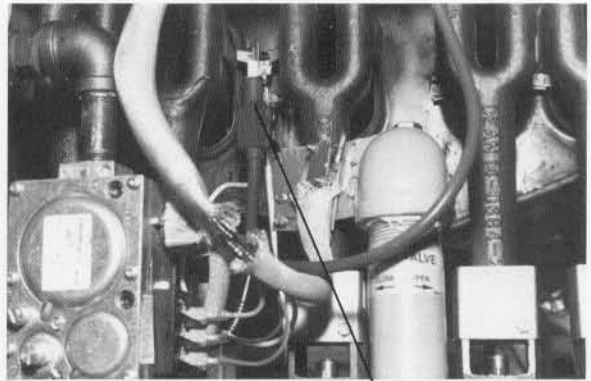

Figure 27

18. Remove frypot front hold-down screw (Fig. 28).

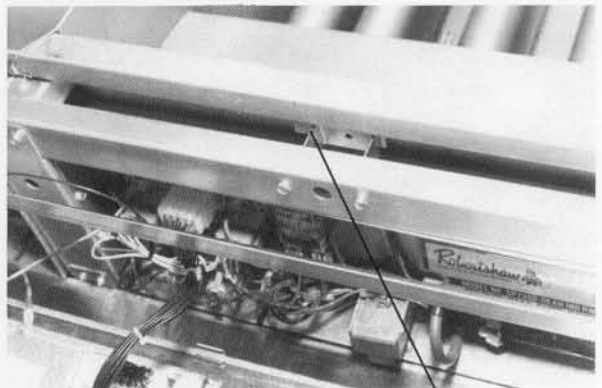

Figure 28

19. Remove push-pull rod from rear oil return valve (Fig. 29).

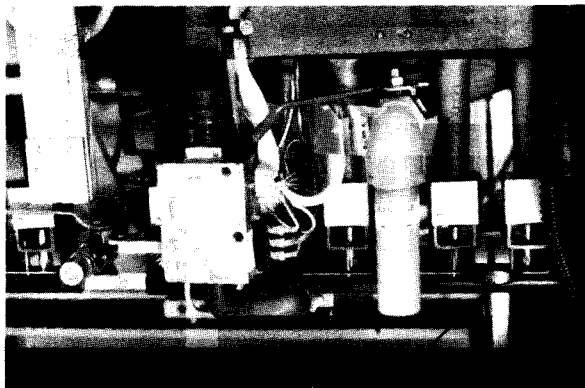

Figure 29

20. Remove hose from oil return valve assembly (Fig. 30).

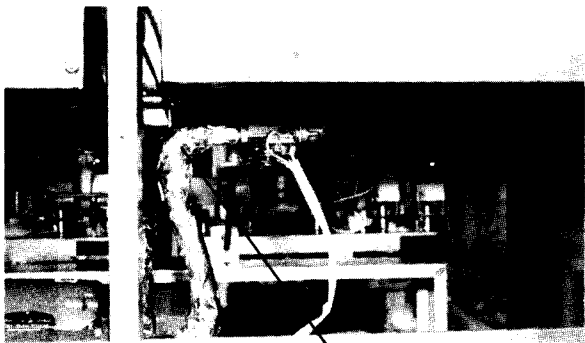

Figure 30

21. Lift frypot straight up.
22. Remove drain valve, ignitor and pilot assembly, burner assembly, gas valve, rear oil return valve assembly, hi-limit thermostat, temperature probe, and burner diffusers from old frypot and install on new frypot.
23. Reverse above procedures to install new frypot. **NOTE:** Apply a small amount of Loctite PST56765 to all male threaded components before installing.

Replace Filter Pan Tube Heater

1. Remove tube cover and disconnect heater wires.
2. Turn pan upside down and remove base including casters.
3. Remove foam insulation, foil tape, and old heater (See Figure 31).

4. Attach new heater to pan suction tube with a piece of foil tape at starting point (see Figure 31).
5. Wrap heater around pan suction tube toward suction fitting in a spiral pattern (see Figure 31).

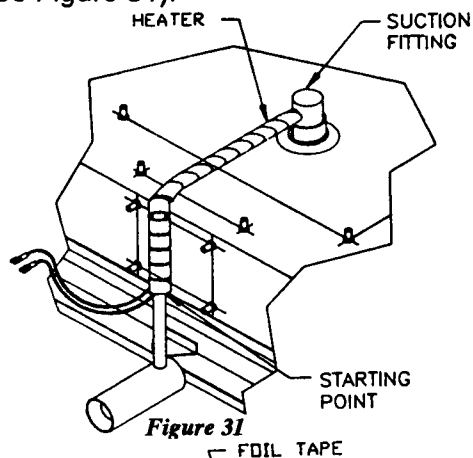

Figure 31

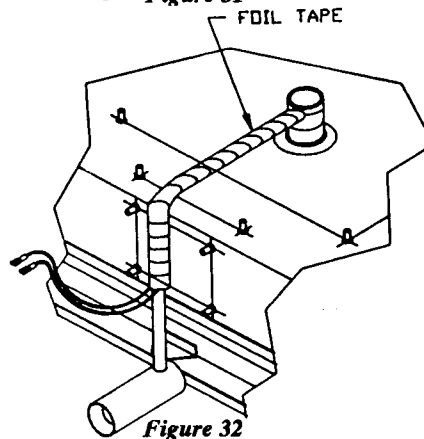

Figure 32

NOTE: The heater must be wrapped tightly around the tube. DO NOT overlap.

6. Wrap the tail end of the heater around suction fitting 2 times and secure with foil tape.
7. Position the heater wires at front of tube and wrap foil tape around heater, tube, and suction fitting overlapping the tape (see Figure 32).

NOTE: Make sure no parts of the heater, tube, and suction tube are showing after wrapping with foil tape.

8. Wrap tube and suction fitting with foam insulating tape and secure with tie wraps (see Figure 33)

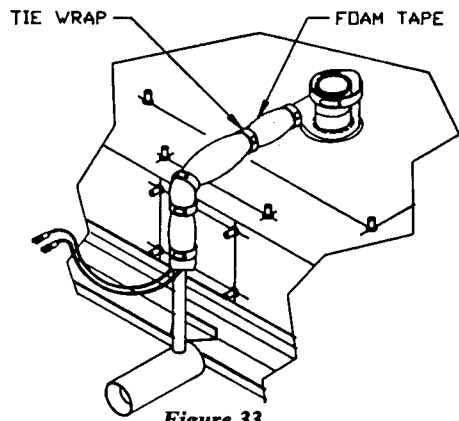

Figure 33

9. Reverse steps 1 and 2 to reassemble base and tube cover to filter pan.
10. Seal all cracks and seams around tube cover and filter pan base with silicone rubber.

13. PREVENTIVE MAINTENANCE

1. CLEAN INSIDE AND OUTSIDE OF FRYER CABINET — DAILY

To clean inside the fryer cabinet, use a dry, clean cloth and wipe all accessible metal surfaces and components to remove accumulated film of shortening and dust.

To clean outside the fryer cabinet, use a clean damp cloth soaked with dishwashing detergent and wipe clean of all shortening, dust, and lint. Rinse with a clean, damp cloth.

2. CLEAN FRYPOT — ONCE A WEEK

WARNING

NEVER operate the fryer(s) with an empty frypot.

To clean the frypot, refer to Section 6 and BOIL-OUT INSTRUCTIONS in Section 4.

3. CLEAN DETACHABLE PARTS AND ACCESSORIES — ONCE A WEEK

Wipe all detachable parts and accessories with a clean, dry cloth. If a heavy film of carbonized shortening has accumulated on the detachable parts and accessories, a clean cloth saturated with Frymaster Fryer "N" Grid-dle Cleaner may be used to remove the film. Rinse the parts and accessories thoroughly with clean water and wipe dry before reinstalling on fryer(s).

4. CHECK GAS VALVE VENT TUBE — EVERY 6 MONTHS

To clean gas valve vent tube, unscrew vent tube fitting from gas valve and remove tube. Insert a piece of ordinary binding wire through the vent tube to remove any obstruction in the tube. Remove clean-out wire and blow through the tube. Reinstall the vent tube with the open end pointing toward rear of fryer and slightly toward floor.

5. CHECK BURNER MANIFOLD PRESSURE — EVERY 4 TO 6 MONTHS

4.0 inches (1.0kPa) W.C. NATURAL GAS,
11.0 inches (2.74kPa) W.C. LP GAS.

Only qualified personnel should perform this task. To check burner manifold pressure, ensure that gas valve knob is turned to the OFF position. Remove pressure tap plug from right end of gas manifold. Insert fitting for gas pressure measuring device into pressure tap hole. Turn gas valve to ON position and turn fryer power switch ON. When burner lights and continues to run, monitor gas pressure reading for correct pressure. To adjust burner gas pressure, remove cap from gas valve regulator and adjust to correct pressure. Turn fryer switch off and gas valve knob off. Remove fitting from right end of manifold and reinstall pressure tap plug.

6. CHECK AIR ADJUSTMENT — EVERY 4 TO 6 MONTHS

A blue flame observed at the burner indicates correct air. If flame at any of the burners is orange or yellow in color, adjust the air shutter for that burner until a blue color is observed.

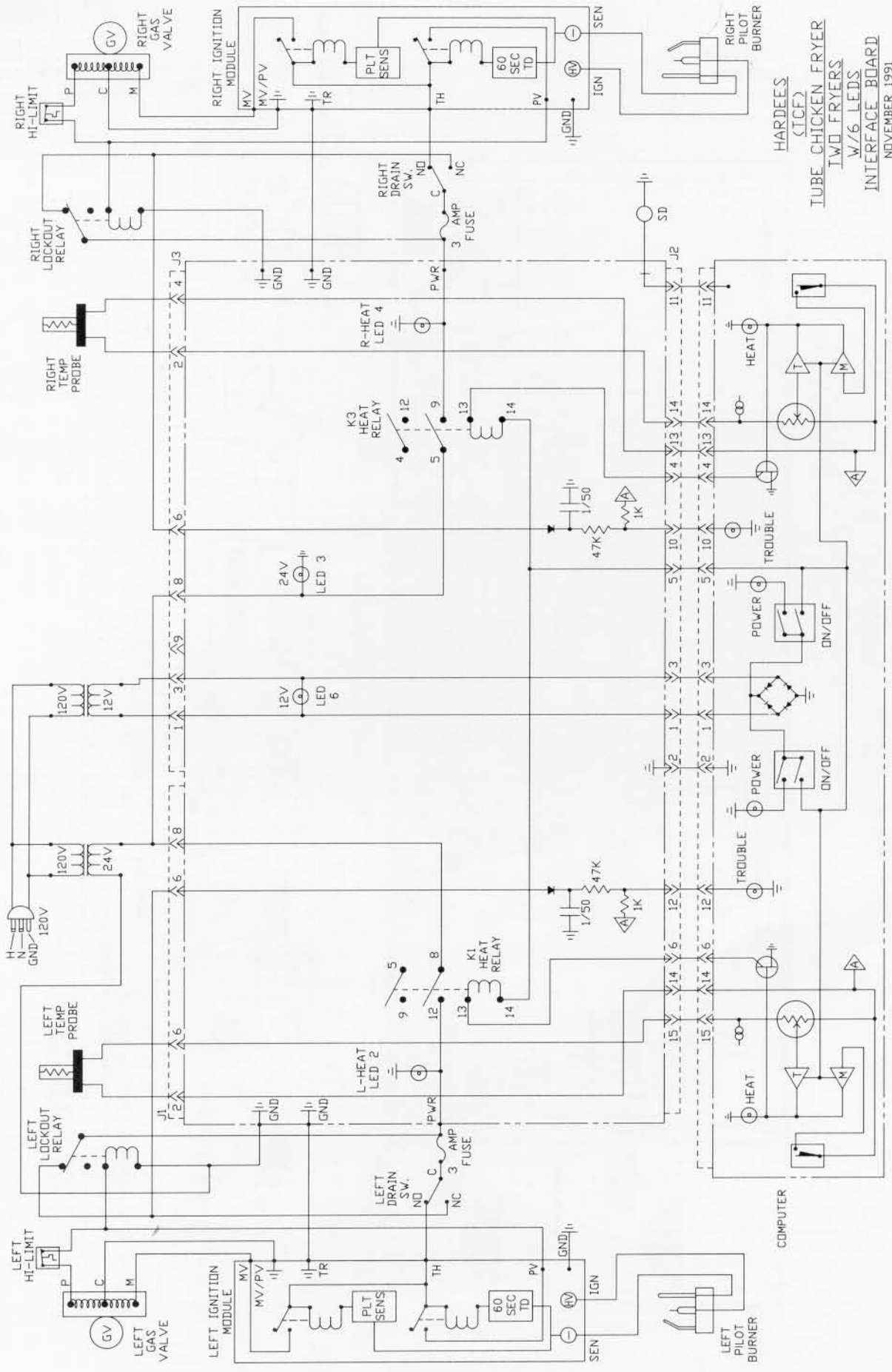

HARDEES
 CTCF2
 TUBE CHICKEN FRYER
 TWO FRYERS
 W/6 LEDS
 INTERFACE BOARD
 NOVEMBER 1991

Wiring Diagram

TRANSFORMER BOX WITH REAR OIL RETURN

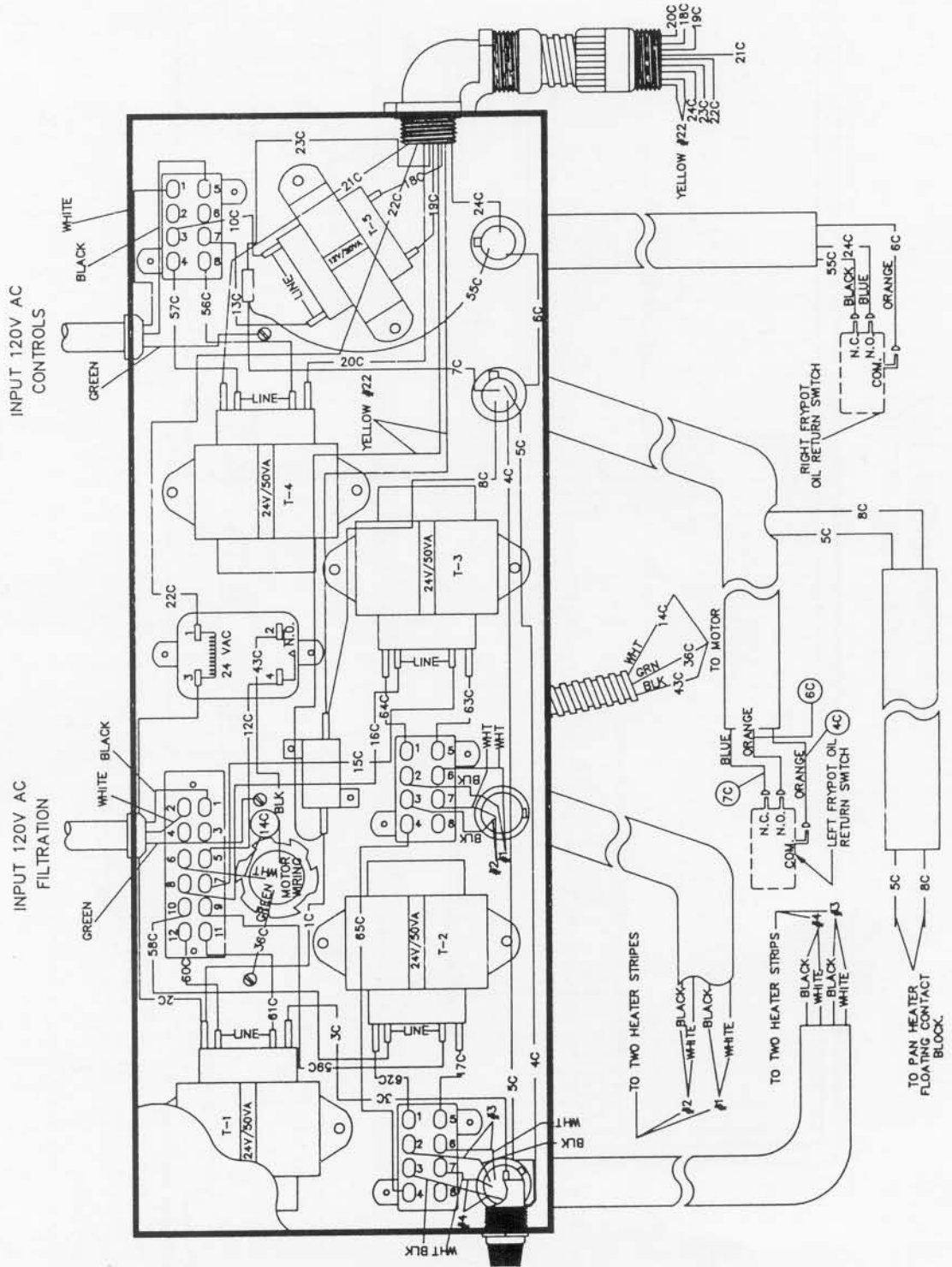

Wiring Diagram

LEFT COMPONENT BOX WITH REAR OIL RETURN

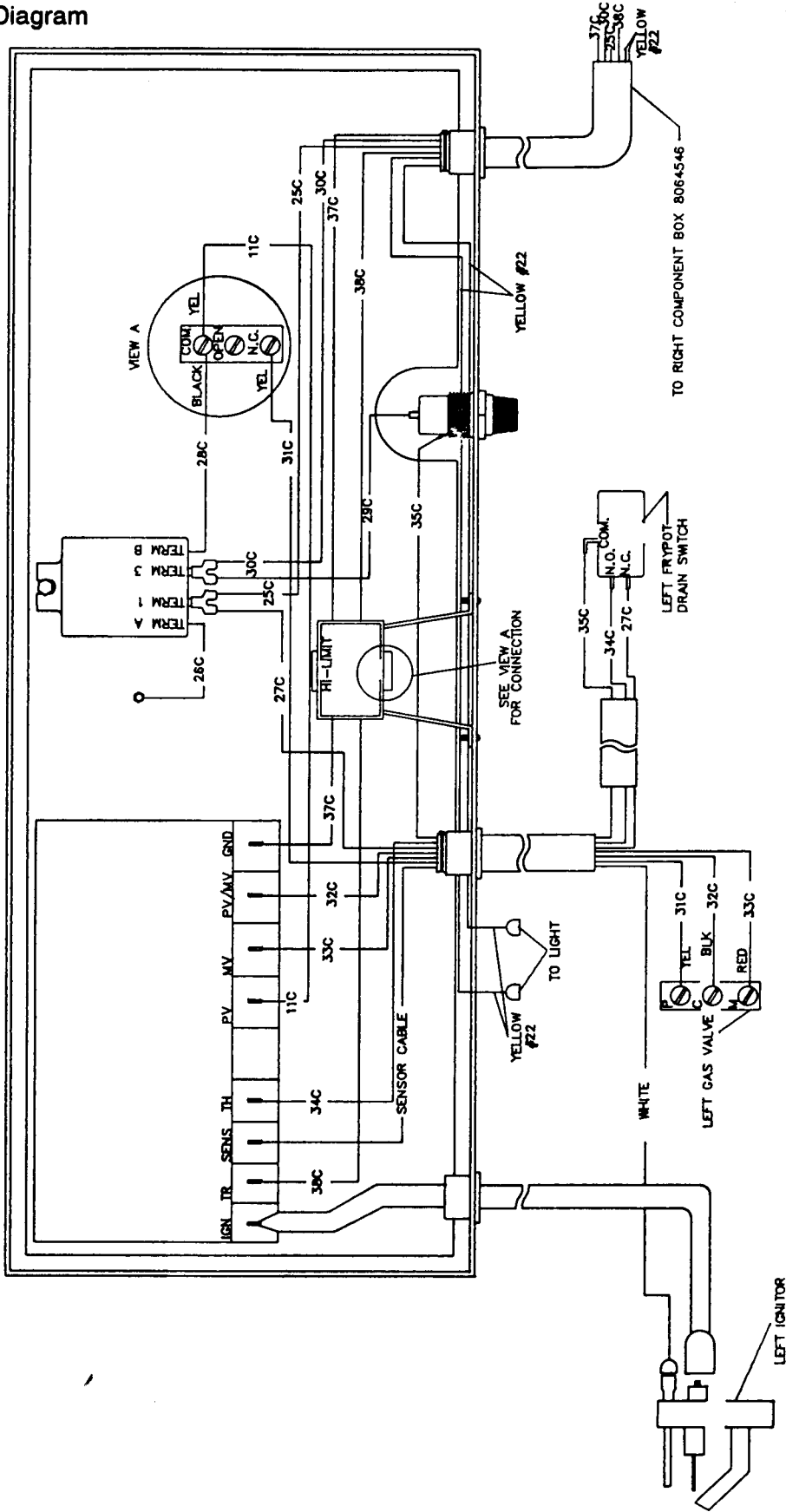

15. INTERFACE BOARD TEST-POINT CHART

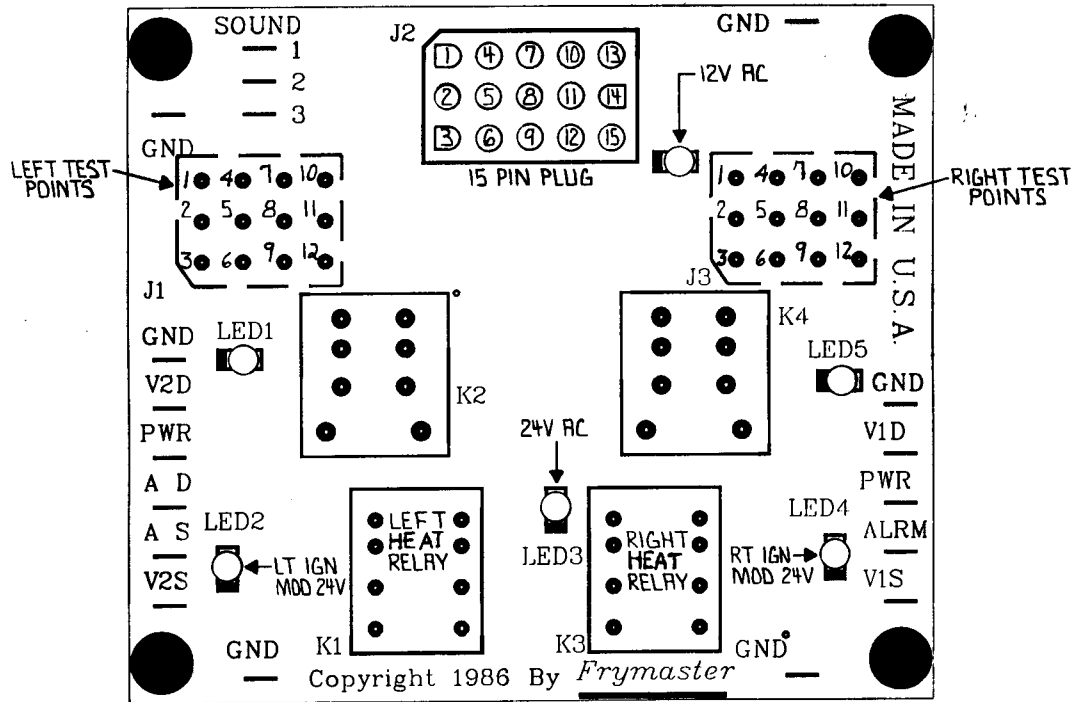

- LED 1 - Not Used**
- LED 2 - Left Ignition Module Power 24 VAC**
- LED 3 - Fryer 24 VAC Power**
- LED 4 - Right Ignition Module Power 24 VAC**
- LED 5 - Not Used**
- LED 6 - Fryer 12 VAC Power**

NOTE: PIN TESTS ARE MADE WHERE WIRES ENTER PLUGS.

PLUG & PIN	TEST FOR	METER SETTING
1. 1 & 3 of J3 or J2	12 Volts AC Power	50 VAC Scale
2. 2 & 4 of J3 or 13 & 14 of J2 for Right Fryer	*Temperature Probe Resistance With J2 Dis-connected.	RX 1000 OHMS
3. 2 & 4 of J1 or 14 & 15 of J2 for Left Fryer	*Temperature Probe Resistance With J2 Dis-connected.	RX 1000 OHMS
4. 8 of J1 & J3 and GND for Left and Right Fryers	24 Volts AC Power	50 VAC Scale
5. PWR & GND Right Side of Board	24 Volts AC to Right Ignition Module With LED 4 ON.	50 VAC Scale
6. PWR & GND Left Side of Board	24 Volts AC to Left Ignition Module With LED 2 ON.	50 VAC Scale
7. 5 of J2 and GND	12 VDC From Computer to K1 & K3 Relay Coils When Computer Heat Indicator Comes ON.	50 VDC Scale
8. 2 of J2 and GND	Good Ground For Computer Through Inter-face Board	RX 1 OHM

*(OHMS Average On Temperature)

1095 OHMS - Temp. 78°F - (26°C)	1602 OHMS - Temp. 325°F - (163°C)
1501 OHMS - Temp. 275°F - (135°C)	1652 OHMS - Temp. 350°F - (176°C)
1551 OHMS - Temp. 300°F - (149°C)	1702 OHMS - Temp. 375°F - (196°C)

(If within + or -5°F (2°C) (8 to 10 OHMS)

High Volume Chicken and Fish Fryer

With advanced electronic programmable controls

**ADVANCED
ELECTRONIC
PROGRAMMABLE
CONTROLS**

EASY-TO-CLEAN

DEEP COLD ZONE



**FOOTPRINT
FILTER –
SAVES
VALUABLE
FLOOR SPACE**

**DOUBLE
STAINLESS
FRYPOTS**

DESIGN FEATURES

Frymaster's new model FP-2TCF chicken and fish fryer features advanced electronic programmable controls and is specifically designed for high volume production of chicken, fish and other breaded products.

Its easy-clean, smooth-surfaced touch-pad control makes programming a breeze.

The FP-2TCF has a minimum 60 lbs. (27 kg) and maximum 70 lbs. (32 kg) shortening capacity, and the frying area is 18" x 18" (457 mm x 457 mm). This 112,000 BTU model has a FootPrint™ filter that fits neatly under the unit saving valuable floor space and is totally self-contained so you can filter more often without wasting labor moving the filter from fryer to fryer.

The exclusive cold zone catches crumbs and sediment and the double stainless steel frypot has a large heat transfer area to fry more product per load.

The FP-2TCF uses 120V (220V-240V for export) power supply and a filter heater is standard.



GAS FRYERS

Frymaster®

A WELBILT Company

FP-2TCF

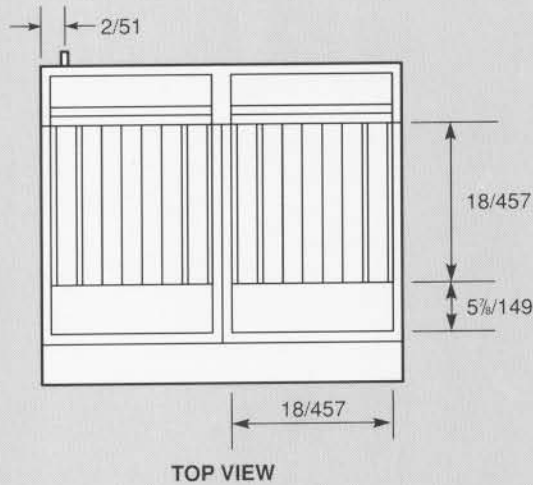

TOP VIEW

inches/mm

NOTES:

- Stainless steel construction
- 112,000 BTU input per frypot
- 120 VAC power supply
- Electronic Ignition
- Natural or LP gas
- Cast iron burners
- 1/3 HP motor
- 5-1/2 GMP pump
- 2" casters
- No heel
- Cleanable filter pan
- Filter heater
- Stainless crumb catcher
- Wand oil return

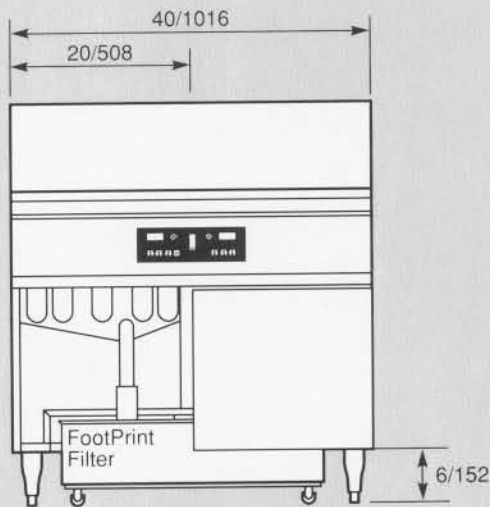

FRONT VIEW

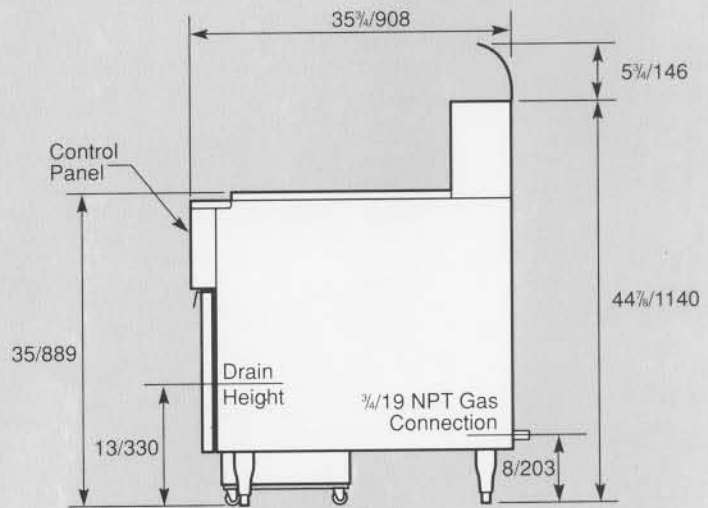

SIDE VIEW

HOW TO SPECIFY

FP-2TCF Stainless steel frypot, stainless steel front, enamel cabinet, analog electronic controller.

STANDARD FEATURES

- Screen type basket rack
- Fryers friend
- Filter paper
- Filter powder
- Twin baskets
- 6" adjustable legs
- Basket hanger
- Flue deflectors
- Sample fryer/griddle cleaner.

OPTIONS AND ACCESSORIES

- Stainless cabinet
- 208 VAC power supply
- Export voltages
- 6" non-adjustable casters
- Separate filter/fryer three prong cord sets
- Frypot covers
- Full baskets
- Flexible metal gas connector with quick-connect coupler
- CM III frying computer
- Chicken skimmer
- Rear oil return

Basic Unit Shipping Weight 740 lbs. (335 kg) Class 85.

THE FRYMASTER CORPORATION

A Welbilt Company

8700 Line Avenue, P.O. Box 51000, Shreveport, Louisiana 71135-1000, Phone 318-865-1711
Toll free 1-800-221-4583, Fax 318-868-5987

Litho in U.S.A. © The Frymaster Corporation
We reserve the right to change specifications appearing in this bulletin without incurring any obligation for equipment previously or subsequently sold