

# Ice Manager™ Diverter Valve System

Order parts online  
www.follettice.com

## Operation and Service Manual After Serial Number C43650

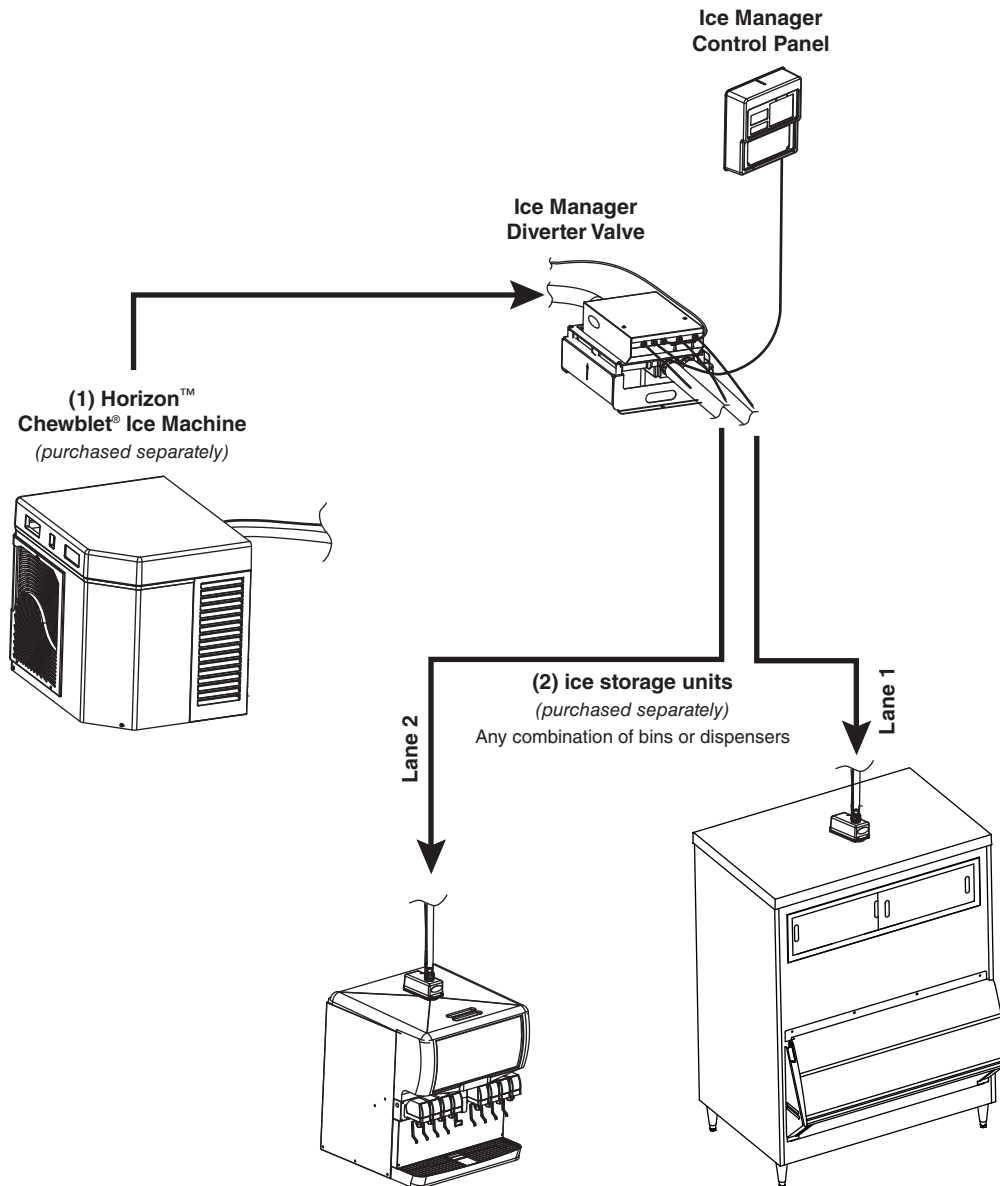

**Following installation, please forward this manual  
to the appropriate operations person.**

## Chewblet® Ice Machine Model Number Configurations

HC
C
1000
A
V
S

Icemaker	Voltage	Series	Condenser	Application	Configuration
MC Maestro Chewblet (400 Series)	C 208-230/60/1 (icemaking head) <i>Self-contained only.</i>	400 up to 454 lbs (206kg)	A Air-cooled, self-contained	V Vision™	S RIDE™
HC Horizon Chewblet (1000, 1400, 1650 Series)	D 115/60/1 (icemaking head) <i>Self-contained and remote. If remote unit, high side is 208-230/60/1.</i>	1000 up to 1036 lbs (471kg)	W Water-cooled, self-contained	H Harmony™	(RIDE remote ice delivery equipment)
HM Horizon Micro Chewblet	E 230/50/1 (icemaking head) <i>Self-contained only.</i>	1400 up to 1450 lbs (658kg)	R Air-cooled, remote condensing unit	B Ice storage bin	T Top-mount
	F 115/60/1 (icemaking head) <i>Remote only. High side is 208-230/60/3.</i>	1650 up to 1580 lbs (717kg)	N Air-cooled, no condensing unit for connection to parallel rack system	J Drop-in M Ice Manager™ diverter valve system	

# Table of contents

## Welcome to Follett

Before you begin . . . . .	4
----------------------------	---

## Specifications

Electrical . . . . .	5
Plumbing . . . . .	5
Temperature requirements . . . . .	5
Dimensions . . . . .	5

## Operation

General information . . . . .	6
Audible alarm . . . . .	6
Cleaning and preventive maintenance . . . . .	7
Preventive maintenance . . . . .	7
Weekly exterior care . . . . .	7
Cleaning and sanitizing . . . . .	7

## Service

System components . . . . .	20
System operation . . . . .	20
Control logic . . . . .	20
Auto mode . . . . .	20
Manual mode . . . . .	20
Diverter valve module . . . . .	21
Control board . . . . .	21
Divert gearmotor . . . . .	21
Divert paddle . . . . .	21
Ice Manager diverter valve wiring diagram . . . . .	22
Control panel . . . . .	23
Membrane switch . . . . .	23
LCD screen . . . . .	23
Audible alarm . . . . .	23
Ultrasonic sensor . . . . .	24
Ice level set points . . . . .	25
To view ice levels . . . . .	25
To view set points . . . . .	25
To change set points . . . . .	25

## Troubleshooting

Ice shortage with audible alarm . . . . .	26
Ice shortage without audible alarm . . . . .	27

## Service Parts

Diverter valve module . . . . .	28
Control panel . . . . .	29
Sensor distribution unit . . . . .	30
Follett Vision™ VU155 Ice Manager kit . . . . .	31
Follett Vision™ VU300 Ice Manager kit . . . . .	32
Cables . . . . .	33

# Welcome to Follett

Follett equipment enjoys a well-deserved reputation for excellent performance, long-term reliability and outstanding after-the-sale support. To ensure that this equipment delivers the same degree of service, we ask that you review the installation manual (provided as a separate document) before beginning to install the unit. Our instructions are designed to help you achieve a trouble-free installation. Should you have any questions or require technical help at any time, please call our technical service group at (877) 612-5086 or +1 (610) 252-7301.

## Before you begin

After uncrating and removing all packing material, inspect the equipment for concealed shipping damage. If damage is found, notify the shipper immediately and contact Follett Corporation so that we can help in the filing of a claim, if necessary.



### CAUTION

- Warranty does not cover exterior or outside installations.
- Moving parts. Do not operate with front cover removed.
- Hot parts. Do not operate with cover removed.
- To reduce risk of shock, disconnect power before servicing.
- Most ice machine cleaners contain citric or phosphoric acid, which can cause skin irritation. Read caution label on product and follow instructions carefully.
- Ice is slippery. Maintain counters and floors around dispenser in a clean and ice-free condition.
- Ice is food. Follow recommended cleaning instructions to maintain cleanliness of delivered ice.

# Specifications

## Electrical

115V, 60Hz, 1ph, 1.5 amps.

8' (2.4m) cord with NEMA 5-15 plug provided. If local code requires hard-wiring, separate disconnects also required.

## Plumbing

Drain line – 15' (4.6m) 3/8" nylon tubing, supplied

## Temperature requirements

Ice Manager components, including ice transport tube, must be operated in ambient temperatures between 40 F and 120 F (5 C and 49 C). Relative humidity not to exceed 55%.

## Dimensions

### Diverter Valve with Mounting Bracket

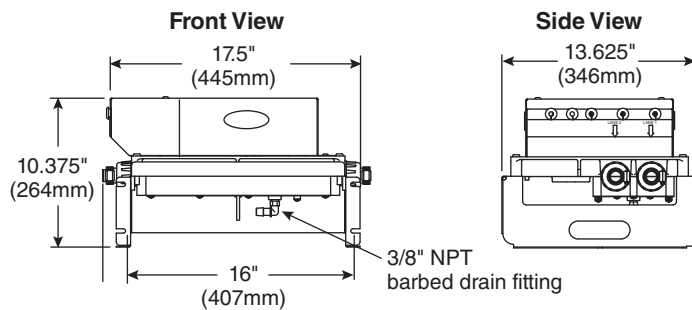

### Control Panel

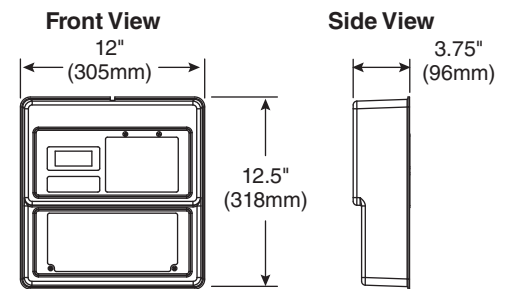

# Operation

## General information

The Ice Manger diverter valve system is designed to direct ice from one Horizon ice machine to two ice storage units. AUTO is the standard operating mode. When selected, ice is directed to the lane 1 storage unit until it reaches the MIN (minimum) set-point. Ice is then directed to the lane 2 storage unit and will continue to fill this lane until the FULL level is achieved. If at any time the ice level in lane 1 storage unit goes below the MIN set-point, ice will be directed back to lane 1 until the MIN level is satisfied. When lane 2 reaches its FULL level, ice will be directed back to lane 1. When both lanes reach their FULL level, the Horizon ice machine will shut off. After a 15-minute delay, the ice machine will be ready to start as soon as the ice level in either of the storage units drops below the FULL set-point.

## Audible alarm

In the event a system error occurs that could cause ice shortages, the audible alarm will be turned ON accompanied by an appropriate error message on the LED screen. To silence the alarm, press any of the push buttons on the control panel. This will silence the alarm for 4 hours, however the error message displayed on the LED screen will remain until the problem is addressed. After 4 hrs, if the error has not been addressed, the audible alarm will resume.

Placing the system in MANUAL MODE will also prevent the alarm from sounding. The error message on the LED screen will still flash, but the alarm will not resume.

See troubleshooting guide on page 26 for causes.

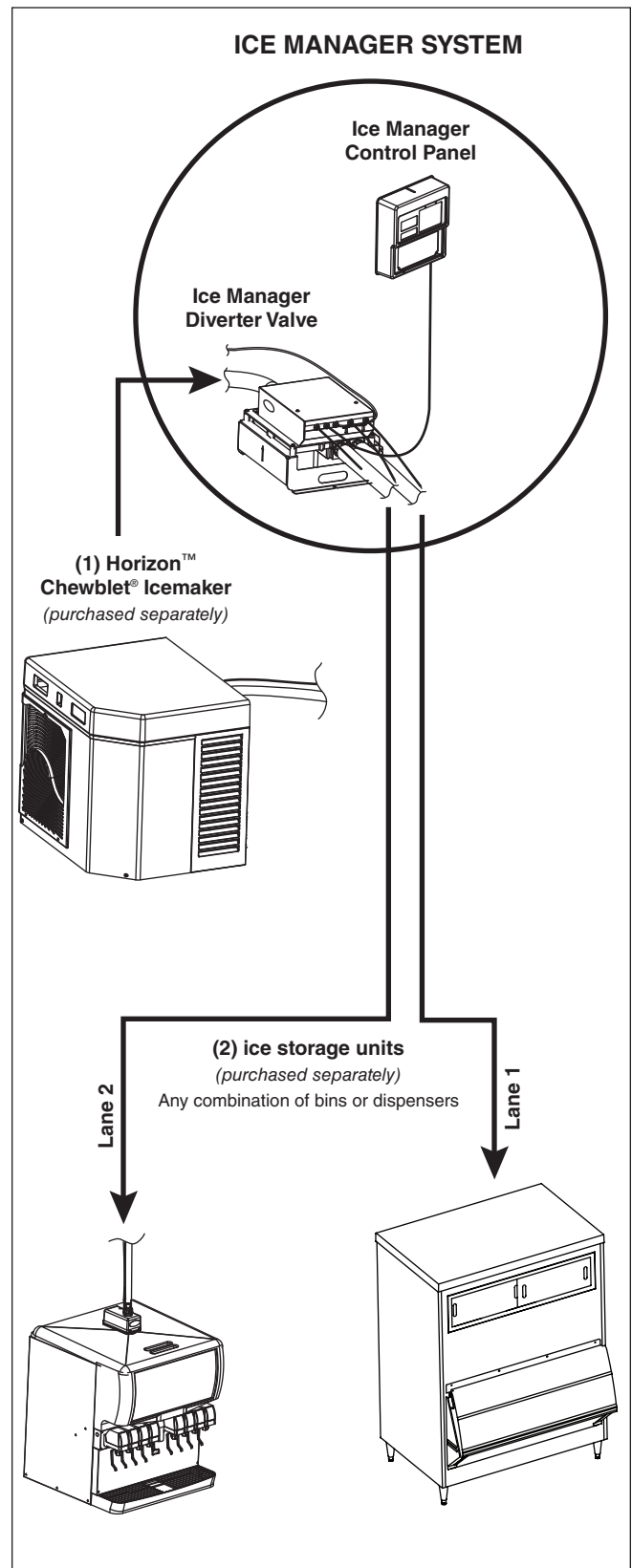

## Cleaning and preventive maintenance

### Preventive maintenance

Periodic cleaning of Follett's Ice Manager diverter valve system is required to ensure peak performance and delivery of clean, sanitary ice. Cleaning of the Ice Manager system, in most cases, should be performed by your facility's maintenance staff or a Follett authorized service agent. Regardless of who performs the cleaning, it is the operator's responsibility to see that this cleaning is performed every 6 months or more often if conditions dictate. Service problems resulting from lack of preventive maintenance will not be covered under the Follett warranty.

### Weekly exterior care

The exterior of the diverter valve and control panel may be cleaned with a soft cloth and mild detergent. The ice machine exterior may be cleaned with a stainless cleaner such as 3M Stainless Steel Cleaner & Polish or equivalent.

**Note:** Do not use bleach to sanitize or clean the ice machine or diverter valve.

### WARNING

- Wear rubber gloves and safety goggles (and/or face shield) when handling ice machine cleaner or sanitizer

### CAUTION

- Use only Follett approved SafeCLEAN™ cleaner (item# 00132001) and NU-CALGON IMS-II SANITIZER.
- Do not mix cleaner and sanitizer solutions together
- DO NOT USE BLEACH
- It is a violation of Federal law to use these solutions in a manner inconsistent with their labeling
- Read and understand all labels printed on packaging before use

**Note:** Complete procedure for cleaning and sanitizing MUST be followed in order shown. Ice must be collected for 10 minutes from each lane before putting ice machine and Ice Manager system back into service.

### Cleaning and sanitizing

1. **To clean ice machine** – Remove ice machine cover. Press the CLEAN button. The machine will drain. Wait for the LO WATER light to come on (Fig. 1).

Fig. 1

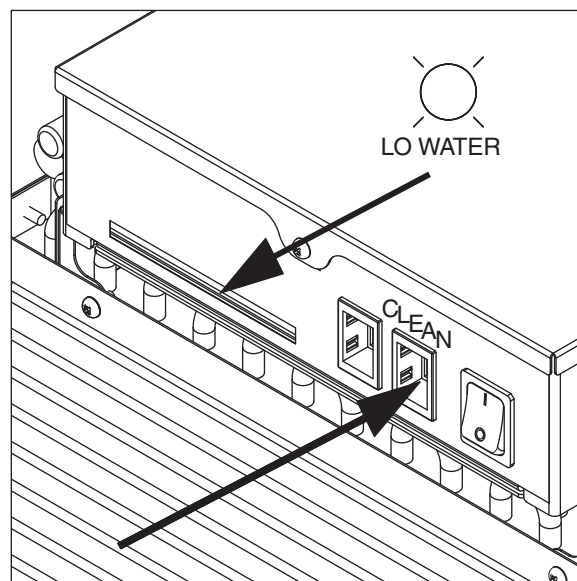

- Mix 1 gallon (3.8L) 120 F (49 C) water and one 7 ounce (198g) packet of Follett SafeCLEAN ice machine cleaner (item# 00132001). Locate cleaning cup. Fill until HI WATER light comes on (Fig. 2).

**Note:** Do not use bleach to sanitize or clean the ice machine.

**Fig. 2**

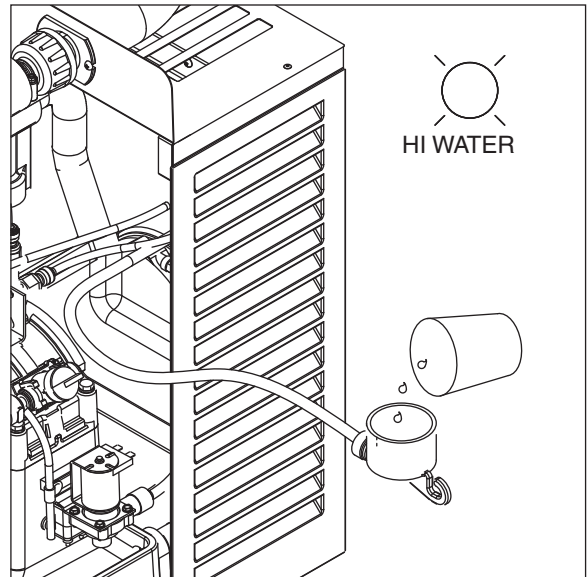

- Replace cover on cleaning cup. Wait until ice machine restarts. Machine will clean, then flush 3 times in approximately 12 minutes (Fig. 3).

**Fig. 3**

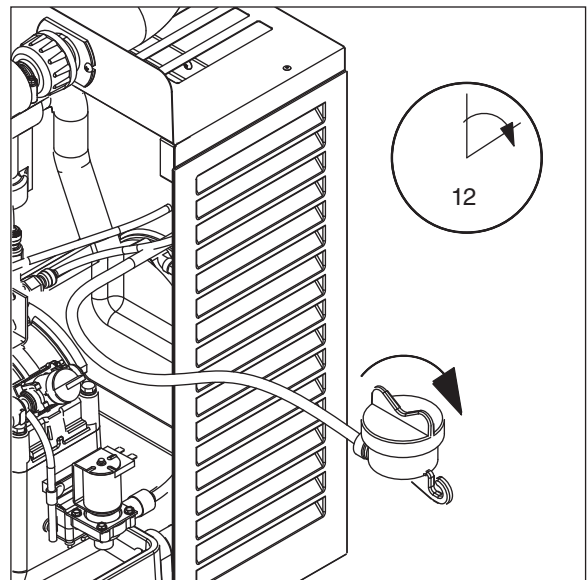

- To sanitize ice machine** – Press CLEAN button. The ice machine will drain. Wait for LO WATER light to come on (Fig. 4).

**Fig. 4**

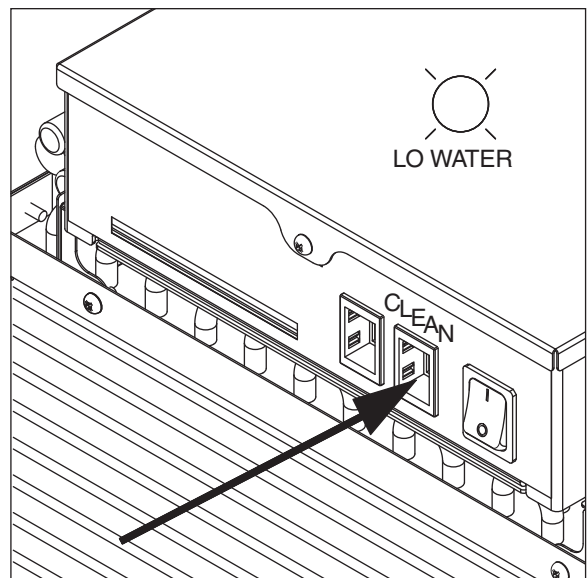

- Mix 1 gallon 120 F (49 C) water and 1.6 ounces (48ml) NU-CALGON IMS-II SANITIZER. Fill until HI WATER light comes on (Fig. 5).

**Note:** Do not use bleach to sanitize or clean the ice machine.

**Fig. 5**

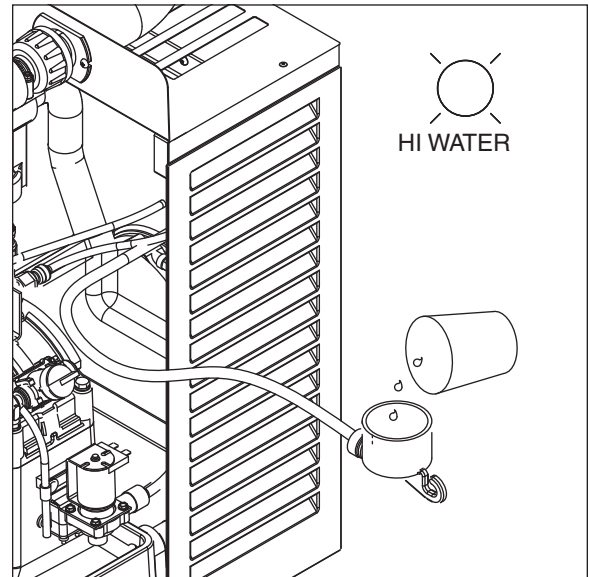

- Replace cover on cleaning cup. Wait until ice machine restarts. Machine will sanitize, then flush 3 times in approximately 12 minutes (Fig. 6).

**Fig. 6**

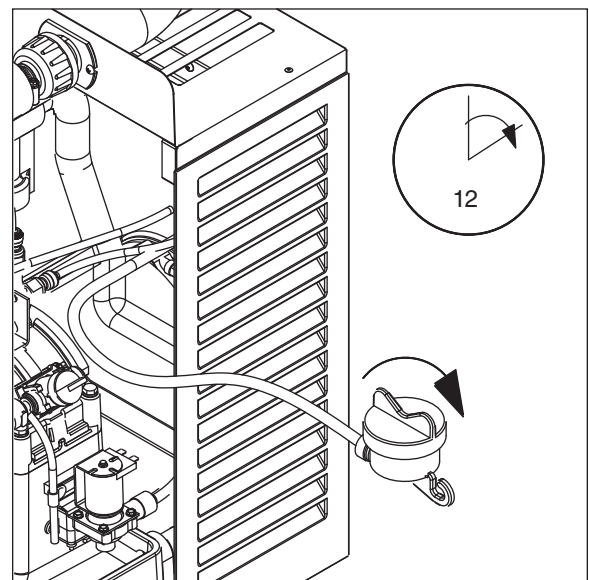

- To sanitize diverter valve** – Press ice machine power switch OFF (Fig. 7).

**Fig. 7**

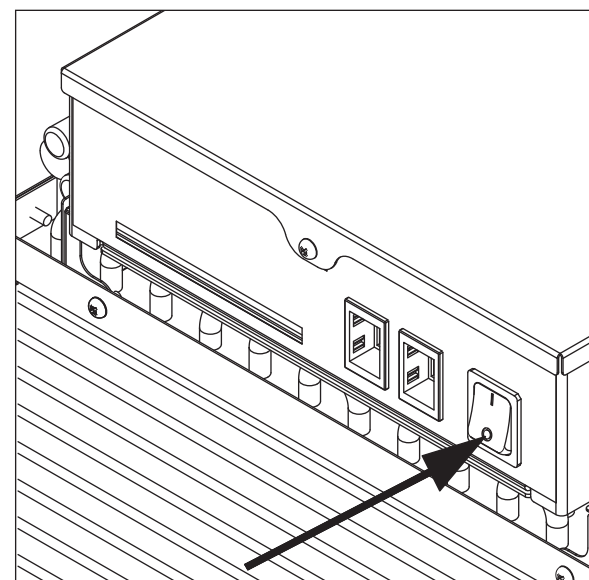
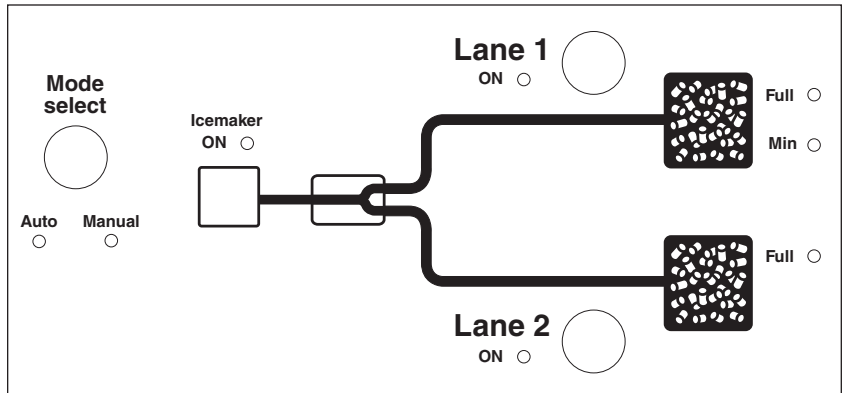

Fig. 8

8. Locate Ice Manager control panel.  
(Fig. 8)



9. To sanitize lanes 1 and 2, diverter valve must be in manual mode. Press the MODE SELECT button on the Ice Manager control panel (Fig. 9). Manual light will come on. If auto light comes on, press MODE SELECT button again.

Fig. 9

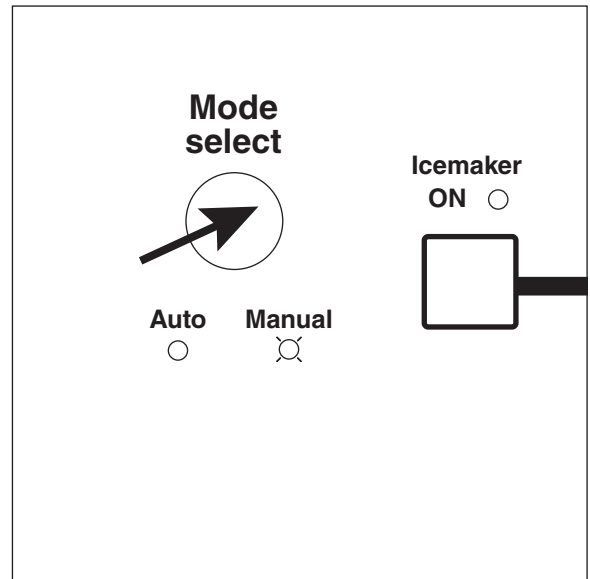

10. **To sanitize lane 1** – Press LANE 1 button (Fig. 10). Lane 1 light will come on.

Fig. 10

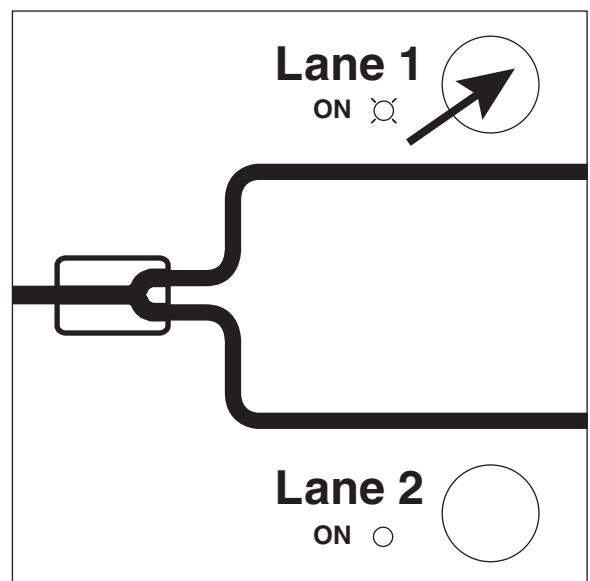

11. Disconnect ice transport tubes from diverter valve unit. Be sure to note lane 1 (Fig. 11.1), lane 2 (Fig. 11.2) and inlet (Fig. 11.3) ice transport tube connections to avoid confusion when reattaching.

**Fig. 11**

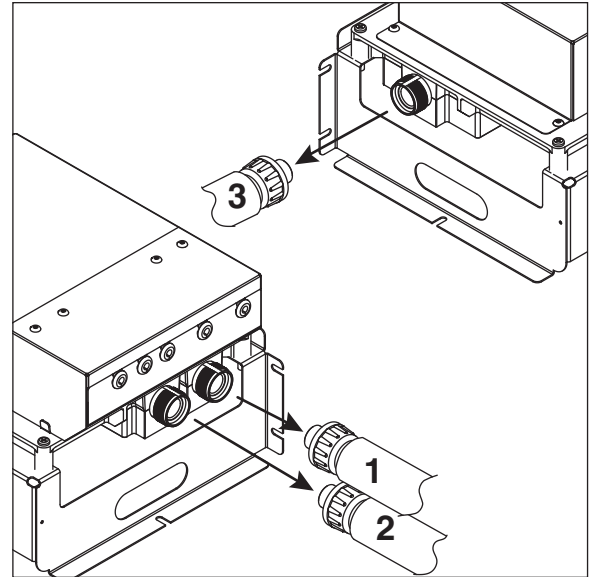

12. Mix 1 gallon 120F (49C) water and 1.6 oz (48ml) NU-CALGON IMS-II SANITIZER.

**Note:** Do not use bleach to sanitize or clean the diverter valve.

Soak supplied brush in sanitizer solution and scrub inside of the diverter valve lane 1 for at least 60 seconds, re-wetting the brush with sanitizer as needed (Fig. 12).

**Fig. 12**

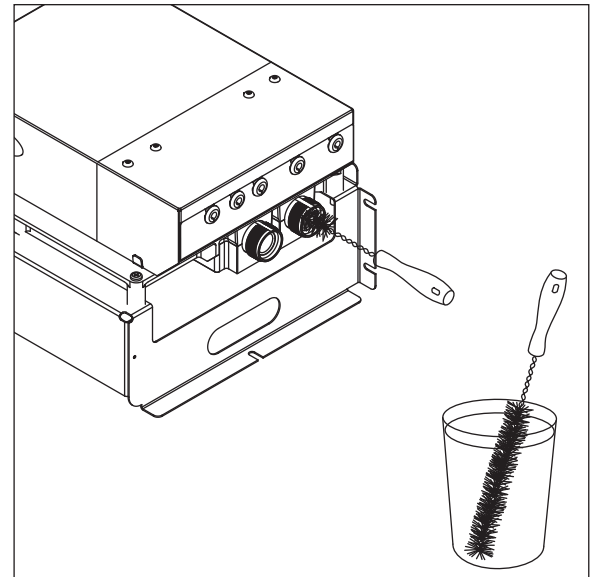

13. Re-wet brush with sanitizer and scrub diverter valve inlet for at least 60 seconds, re-wetting the brush with sanitizer as needed (Fig. 13).

**Fig. 13**

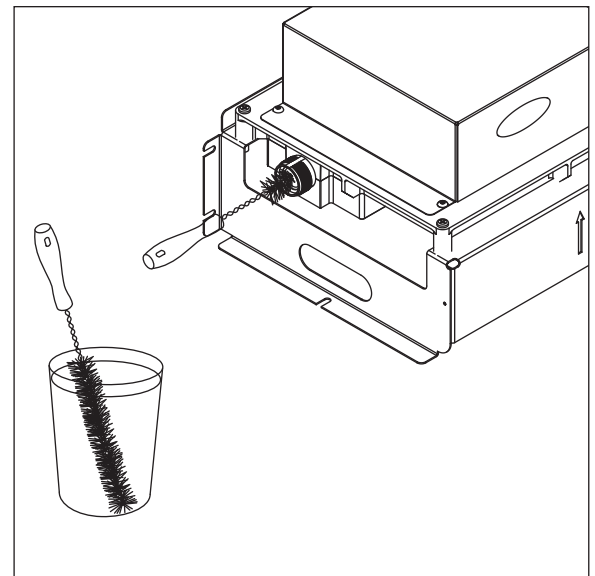

14. To sanitize lane 2 – Press LANE 2 button (Fig. 14). Lane 2 light will come on.

Fig. 14

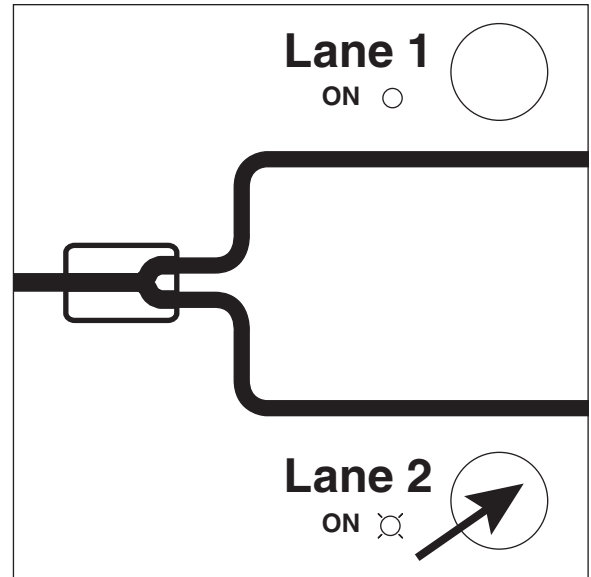

15. Soak supplied brush in sanitizer solution and scrub inside of the diverter valve Lane 2 for at least 60 seconds, re-wetting the brush with sanitizer as needed (Fig. 15).

Fig. 15

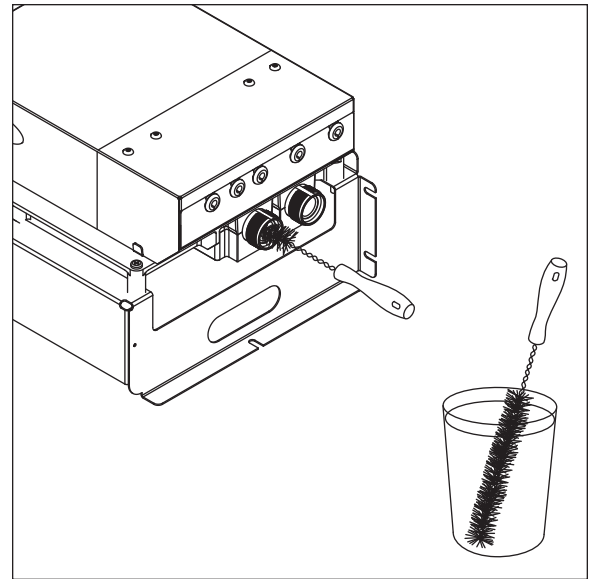

16. Re-wet brush with sanitizer and scrub inlet for at least 60 seconds, re-wetting the brush with sanitizer as needed (Fig. 16).

**Note:** Inlet must be scrubbed with both lane 1 and lane 2 settings to be sure each lane is cleaned and sanitized.

Fig. 16

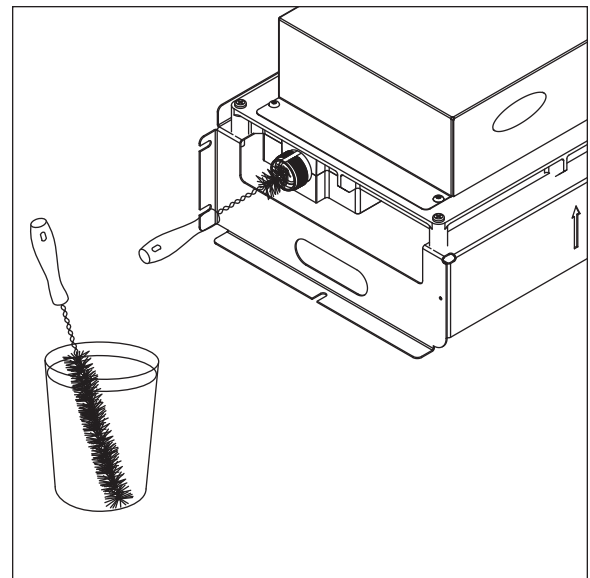

17. Rinse brush in plain, 120 F (49 C) water. Rinse lane 1 (Fig. 17.1), lane 2 (Fig. 17.2), and inlet (Fig. 17.3) with clear water repeating steps 12 through 16 to be sure each lane is rinsed thoroughly.

**Fig. 17**

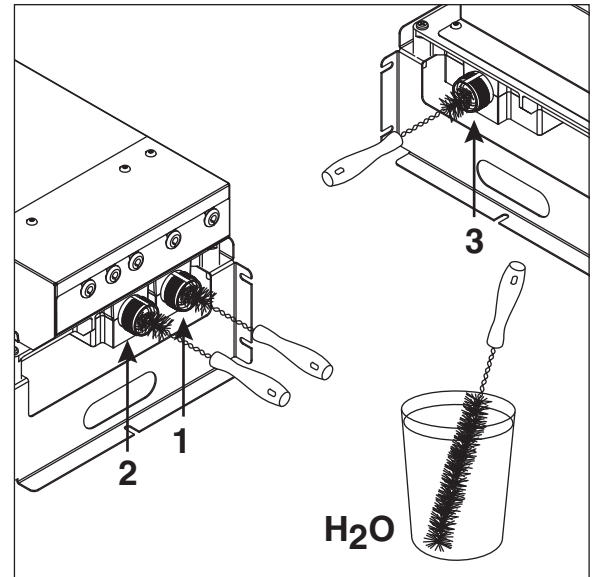

18. Re-connect ice transport tube to lane 1 (Fig. 18.1), lane 2, (Fig. 18.2) and inlet (Fig. 18.3).

**Fig. 18**

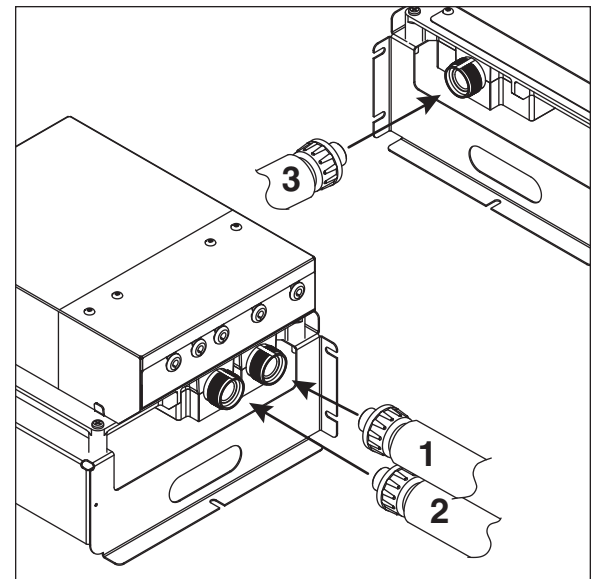

19. To sanitize lane 1 ice transport tube – Press ice machine power switch OFF (Fig. 19).

Fig. 19

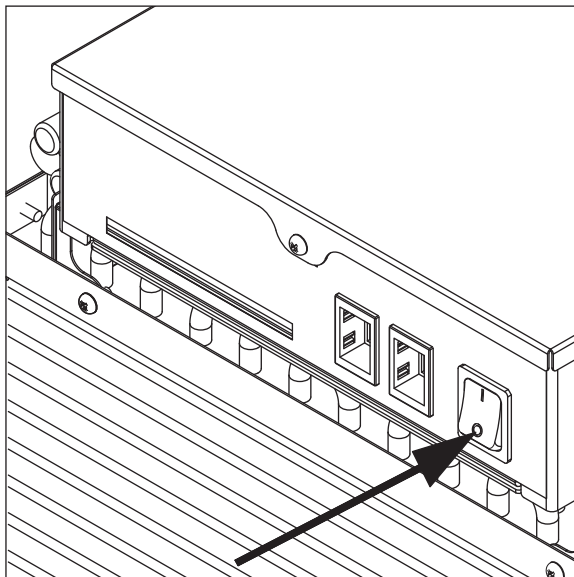

20. Verify that Ice Manager is in manual mode (Fig. 20). Manual light should be on. If auto light is on, press MODE SELECT button to switch to manual mode.

Fig. 20

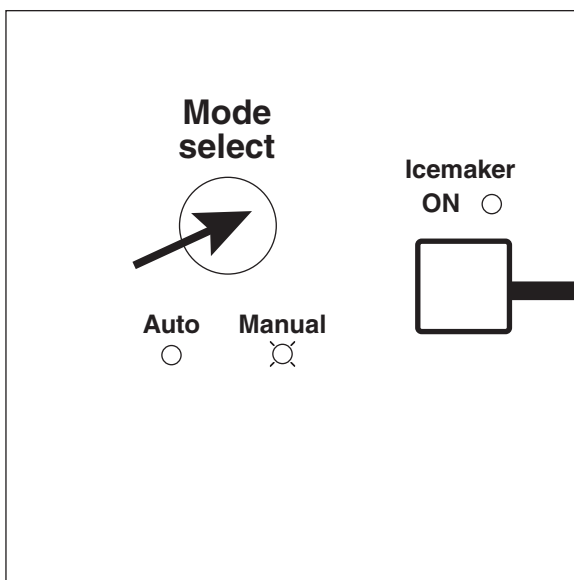

21. Press LANE 1 button (Fig. 21). Lane 1 light will come on.

Fig. 21

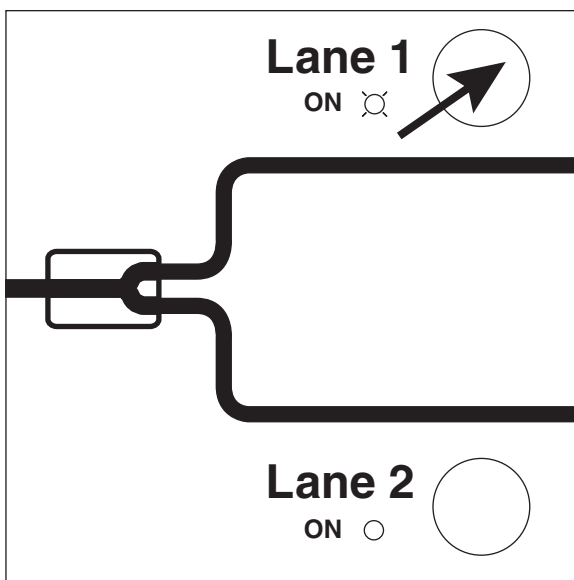

22. Disconnect coupling from ice machine as shown (Fig. 22).

**Fig. 22**

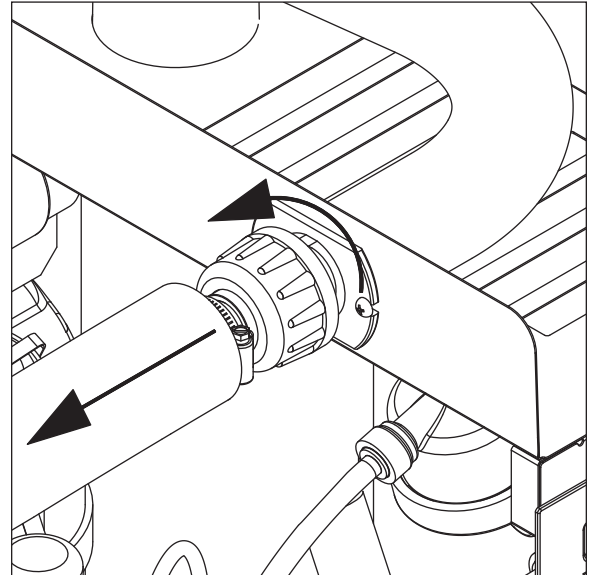

23. Using disposable food service grade gloves, insert dry Sani-Sponge™ (kit part# 00132068). Then insert Sani-Sponge soaked in Nu-Calgon IMS-II sanitizer solution. Push both Sani-Sponges down ice transport tube with supplied pusher tube (Fig. 23).

**Fig. 23**

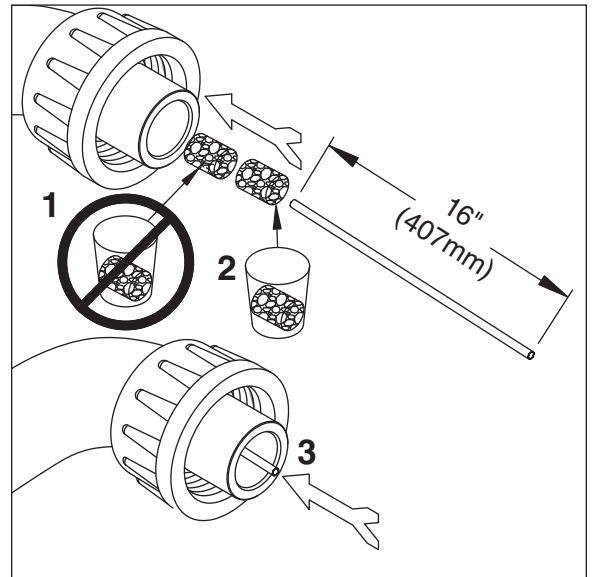

24. Remove 16" (407mm) pusher tube (Fig. 24).

**Fig. 24**

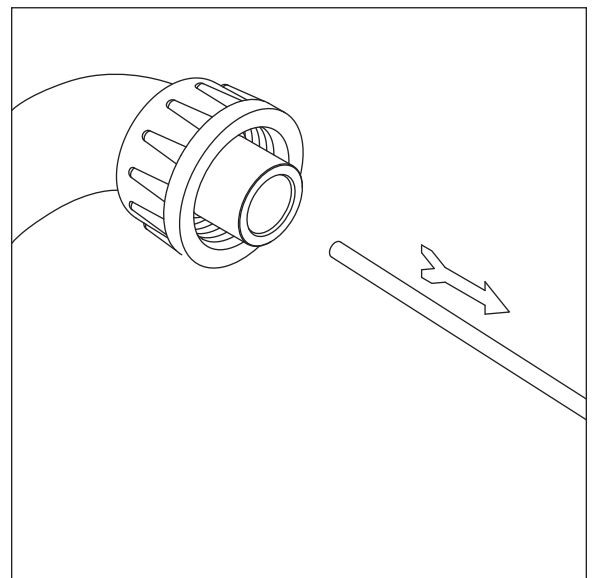

25. Reconnect coupling. Press ice machine power switch ON. Ice pushes Sani-Sponges through tube (Fig. 25).

**Fig. 25**

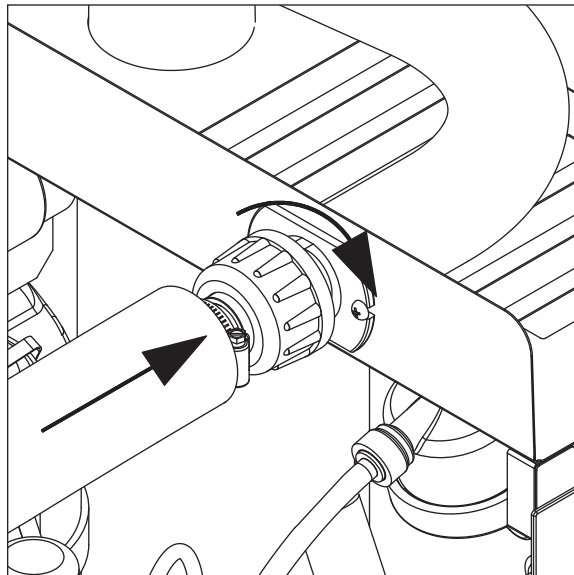

26. Place a sanitary (2 gallon or larger) container in bin or dispenser to collect Sani-Sponges and ice for 10 minutes. Collect 5.5 lbs (3kg) of ice from unit. Discard ice and Sani-Sponges (Fig. 26).

**Fig. 26**

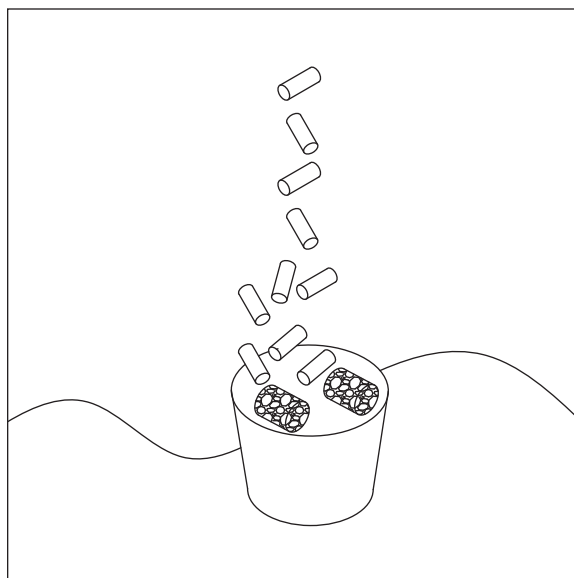

- 27. To sanitize lane 2 ice transport tube – Press ice machine power switch OFF (Fig. 27).

Fig. 27

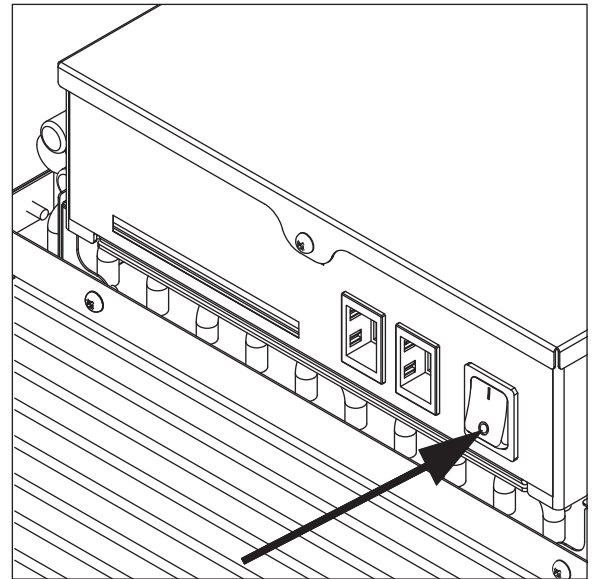

- 28. Verify that Ice Manager is in manual mode (Fig. 28). Manual light should be on. If auto light is on, press MODE SELECT button to switch to manual mode.

Fig. 28

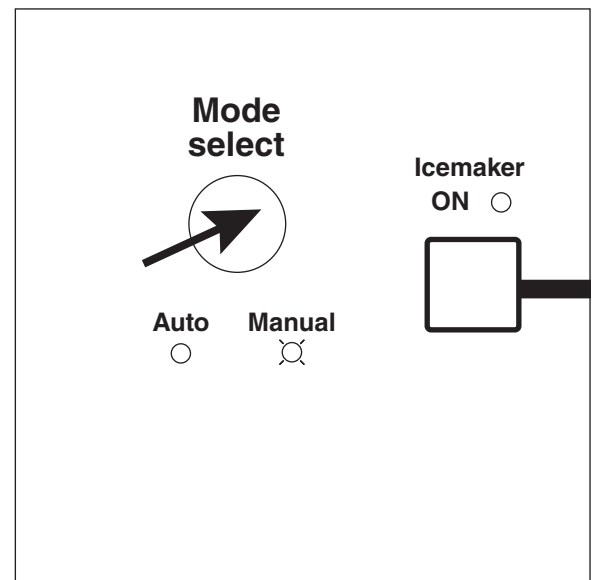

- 18. Press LANE 2 button (Fig. 29). Lane 2 light will come on.

Fig. 29

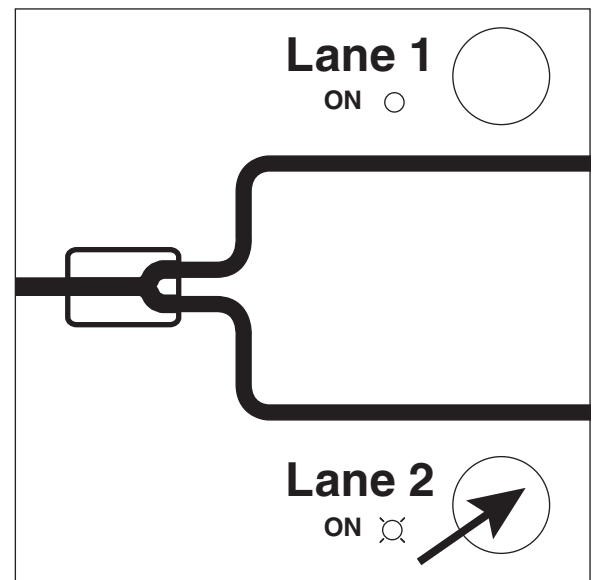

30. Disconnect coupling from ice machine as shown (Fig. 30).

**Fig. 30**

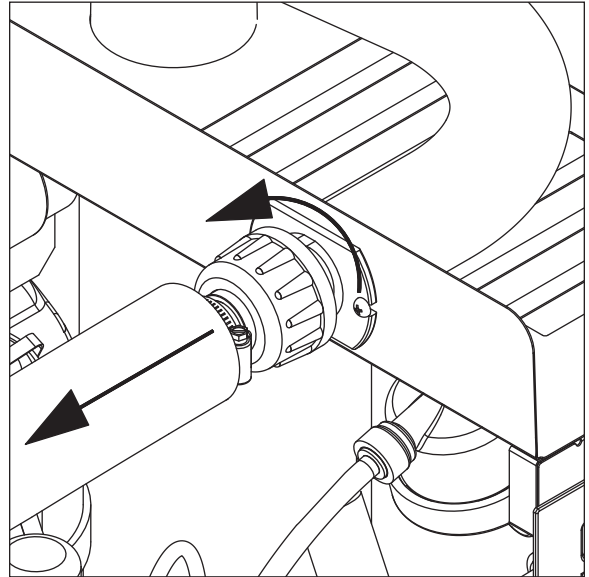

31. Using disposable food service grade gloves, insert dry Sani-Sponge (kit part# 00132068). Then insert Sani-Sponge soaked in Nu-Calgon IMS-II sanitizer solution. Push both Sani-Sponges down ice transport tube with supplied pusher tube (Fig. 31).

**Fig. 31**

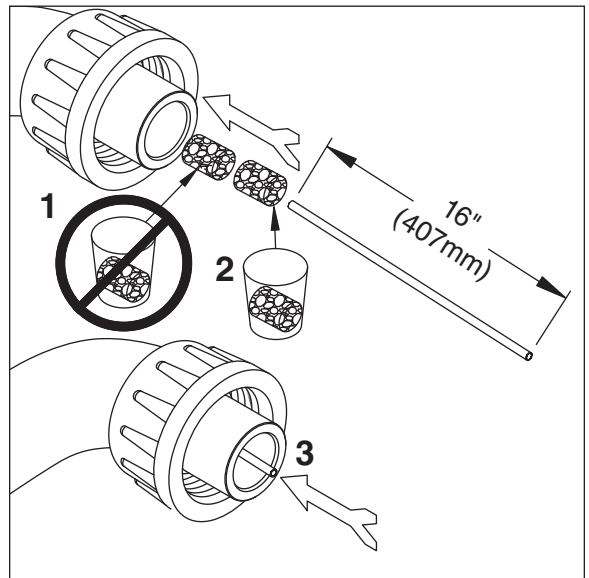

32. Remove and discard 16" (407mm) pusher tube (Fig. 32).

**Fig. 32**

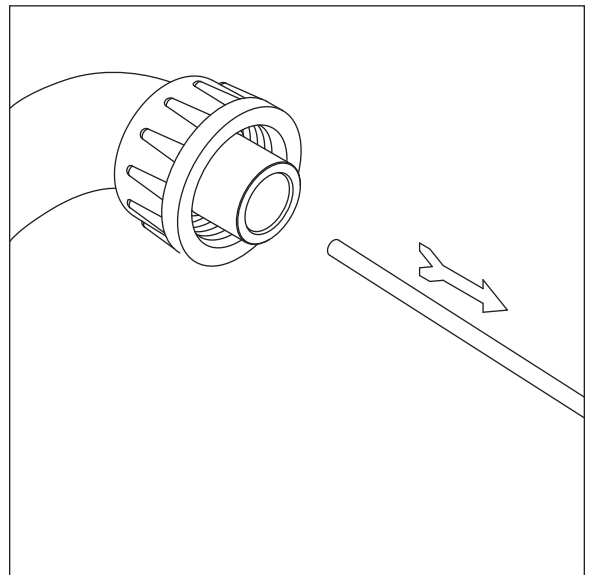

33. Reconnect coupling. Press ice machine power switch ON. Ice pushes Sani-Sponges through tube (Fig. 33).

**Fig. 33**

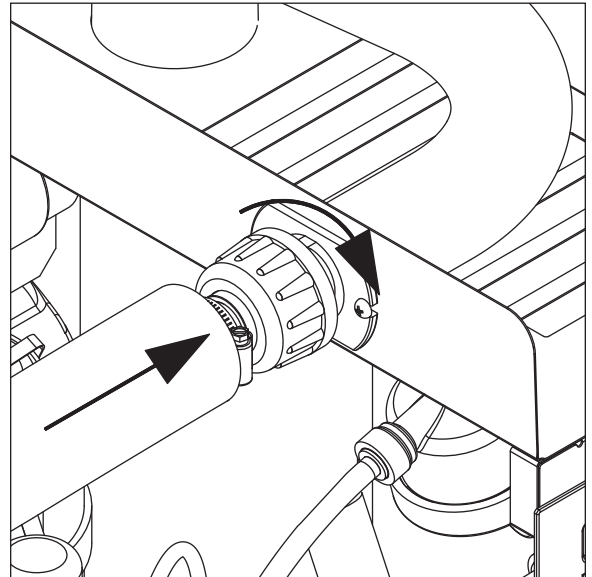

34. Place a sanitary (2 gallon or larger) container in bin or dispenser to collect Sani-Sponges and ice for 10 minutes. Collect 5.5 lbs (3kg) of ice from unit. Discard ice and Sani-Sponges (Fig. 34).

**Fig. 34**

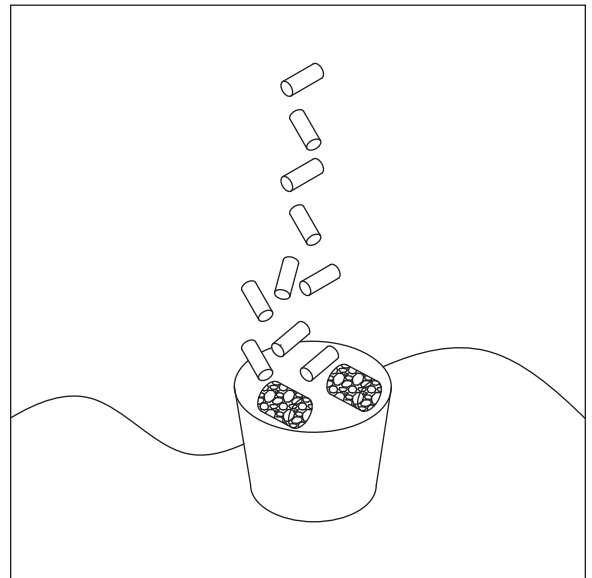

35. Press MODE SELECT button on Ice Manager control panel to switch to auto mode (Fig. 35). Auto light will come on.

**Fig. 35**

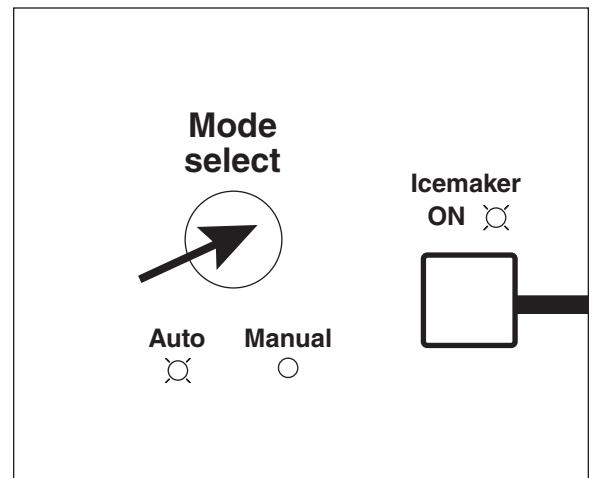

# Service

## System components

Follett's Ice Manager diverter valve system consists of following major components:

- Diverter valve module
- Control panel module
- Ice transport tube lane 1 with a dedicated sensor cable 1
- Ice transport tube lane 2 with a dedicated sensor cable 2
- Ice level sensor / ice distribution module for lane 1
- Ice level sensor / ice distribution module for lane 2

## System operation

The Ice Manager diverter valve system is designed to control the feeding of ice from one Horizon ice machine to two ice storage units. There are different ice level set-points for ice storage units.

The ice storage unit for lane 1 has two ice level set points, MIN and FULL, while the ice storage unit for lane 2 has only one - FULL. There is also a DIF (Differential) setting for each lane that initiates refill of ice.

**Note:** Ice Manager diverter valve system comes with factory pre-set values for MIN, FULL and DIF (differential) parameters. If required the pre-set values can be field modified. (See the ice level set point on page 25.)

### Control logic

Ultrasonic sensors for lane 1 and lane 2 detect ice level and send an analog signal between 0.5vdc to 4.5vdc back to diverter valve control board. This signal is converted into distance (in inches) from the sensor face to the ice surface.

An appropriate light on the control panel comes on indicating the ice level reached either MIN or FULL levels for lane 1 or FULL level for a lane 2 units.

### Auto mode

AUTO is the standard operating mode for the Ice Manager diverter valve system. In AUTO mode, the system will automatically direct the ice according to the sensor set point levels.

On start up, when AUTO mode is selected the diverter valve directs ice through lane 1 to the ice storage unit until the MIN level is satisfied.

The diverter valve will then switch and direct ice through lane 2 until its ice storage unit FULL level is satisfied.

If during this time the ice level in lane 1 ice storage unit drops below the MIN level, then the diverter valve will re-direct ice flow back to lane 1 and continue feeding ice through the lane 1 until the ice storage unit MIN level is satisfied again. The cycle will continue until FULL level for both ice storage units are reached.

When the ice level in both ice storage units is at the FULL level the diverter valve shuts off the signal to the ice machine which goes into a 15 min delay. When the delay period expires, the control logic will allow the ice machine to restart when either sensor detects ice level drop below the FULL set-point.

**Note:** There is a 30 second time delay function programmed into the control logic. This function requires 30 seconds of a steady ice level reading exceeding a set-point before the control logic initiates any action. Therefore, a momentary ice level change measured by the ice level sensors will not trigger a shut-down or divert.

### Manual mode

For Ice Manager diverter valve system cleaning and sanitizing, and some special situations (see a troubleshooting guide on page 26), a MANUAL mode is available. MANUAL mode overrides AUTO mode and allows the operator to select the lane.

In order to switch between AUTO and MANUAL modes push the MODE SELECT button located on the control panel. While in MANUAL mode, pressing either lane 1 or lane 2 buttons will divert ice flow accordingly.

**Note:** When in manual mode ice level sensors will not control the divert action, however the ice sensors will continue to control the ice machine. When the FULL ice level in designated ice storage unit is satisfied the ice machine will be shut off.

## Diverter valve module

There are three major functional components within the diverter valve.

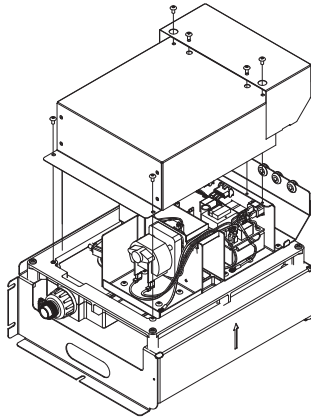

### Control board

(Fig. 36)

The control board manages all functions of the Ice Manager diverter valve system based on signals received from lane 1 and lane 2 ice level sensors. It diverts ice flow from one lane to another, while ice storage units are filled and shuts off ice machine when both dispensers are at the FULL level.

The control board communicates with the Horizon ice machine and the sensors for the lane 1 and lane 2 via appropriate signal cables. It supplies 120/60/1 electrical power to the divert gearmotor assembly and monitors the divert gearmotor position status based on inputs from two magnetic switches mounted to the gearmotor bracket. It also provides 12vdc power to the control panel via the gray control cable.

### Divert gearmotor

(Fig. 37)

The divert gearmotor assembly is linked to the divert paddle assembly and manages ice flow direction.

### Divert paddle

(Fig. 38)

Located inside of the body of the diverter valve module, the divert paddle is driven by the gearmotor and switches ice flow from one internal channel to another.

Fig. 36

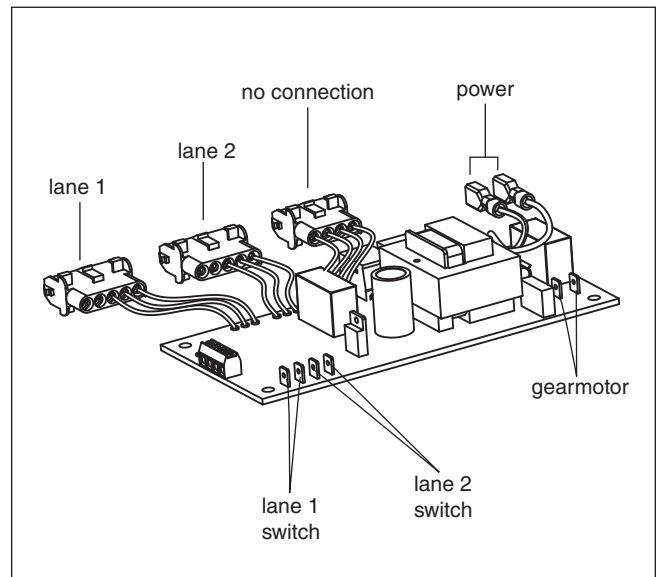

Fig. 37

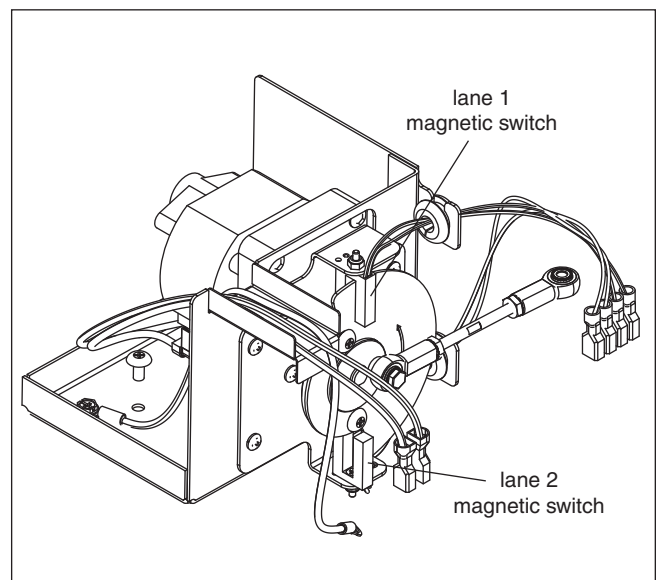
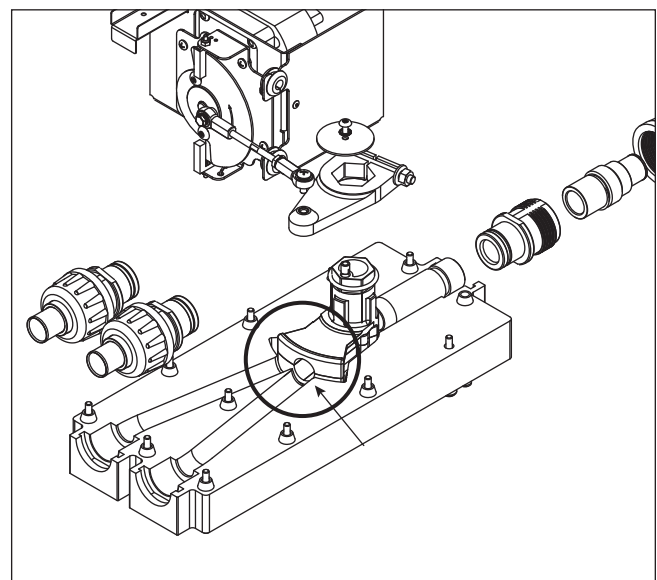
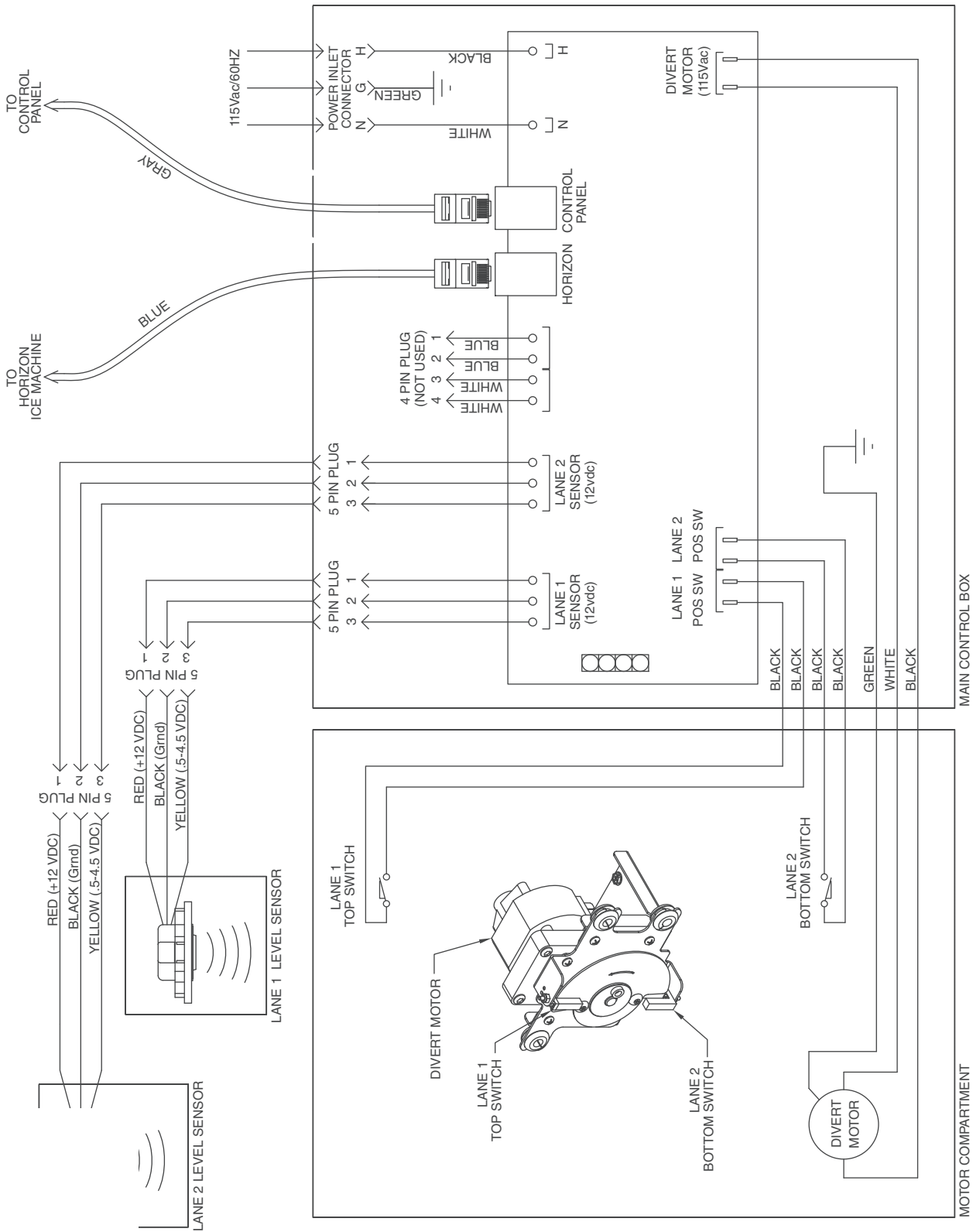

Fig. 38



# Ice Manager diverter valve wiring diagram



## Control panel

(Fig. 39)

The control panel is powered with 12vdc coming from the diverter valve control board via the gray control cable. It contains a membrane switch and an LCD screen.

**Note:** The diverter valve control board receives power directly from the outlet. The system will be running even if the control panel is not operational.

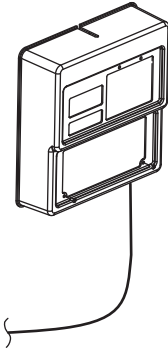

## Membrane switch

(Fig. 39)

The membrane switch contains LED indicators offering a quick system status.

ICE MACHINE ON light - a steady LED indicates the ice machine is running.

LANE 1 ON light - a steady LED indicates ice is directed through lane 1

LANE 2 ON light - a steady LED indicates ice is directed through lane 2

FULL light – a steady LED indicates the ice has reached the FULL level set-point

MIN light – a steady LED indicates the ice has reached the minimum level set-point

## LCD screen

(Fig. 40)

The LCD screen shows ice level readings in both ice storage units and overall Ice Manager diverter valve system status. In case of System errors the LCD screen displays the nature of the failure and provides necessary details.

(See troubleshooting on page 26 for details.)

## Audible alarm

In the event a system error occurs that could cause ice shortages, the audible alarm will be turned ON accompanied by an appropriate error message on the LCD screen. To silence the alarm, press any of the push buttons on the control panel. This will silence the alarm for 4 hours, however the error message displayed on the LCD screen will remain until the problem is addressed. After 4 hrs, if the error has not been addressed, the audible alarm will resume.

Placing the system in MANUAL MODE will also prevent the alarm from sounding. The error message on the LCD screen will still flash, but the alarm will not resume.

See troubleshooting guide on page 26 for causes.

Fig. 39

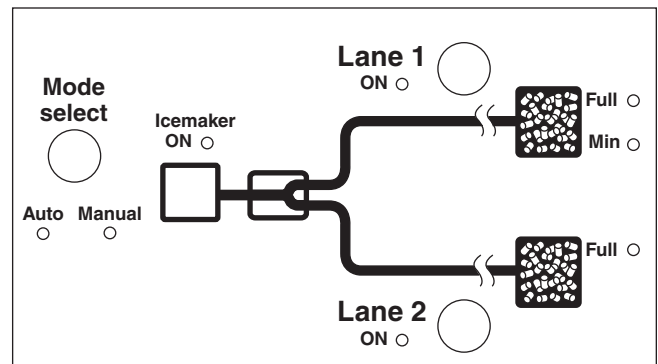
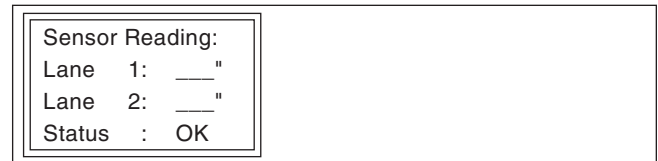

Fig. 40



## Ultrasonic sensor

(Fig. 42)

The ultrasonic sensor measures ice level in each ice storage unit. The sensor outputs an analog voltage between 0.5vdc and 4.5vdc corresponding the ice level distance from the face of the sensor.

Fig. 41

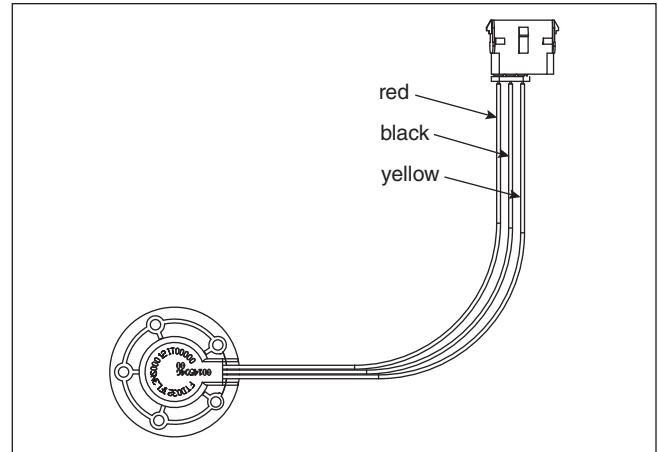

## Ice level set points

Ice level set points are set at the factory and normally do not need to be changed. Setting recommendations are shown in the table below. Please contact Follett Technical Services toll free at (877) 612-5086 or +1 (610) 252-7301 prior to changing ice level set points.

	Factory settings
LANE 1	Full 10" Min 14" Dif 3"
LANE 2	Full 10" Dif 3"

### To view ice levels

1. Locate LED screen on Ice Manager control panel. Initial screen will show ice levels for lane 1 and lane 2 and diverter valve status (Fig. 43).

### To view set points

1. Press and hold both MODE SELECT and LANE 1 buttons until LANE 1 SETUP appears on the display (Fig. 44).  
Note: Default/factory-set ice level sensor settings are shown.
2. To view lane 2, press MODE SELECT to navigate to lane 2 setup (Fig. 45).

### To change set points

1. Press and hold both MODE SELECT and LANE 1 buttons until LANE 1 SETUP appears on the display (Fig. 44).  
**Note:** Default/factory-set ice level sensor settings are shown.
2. Press LANE 1 button to move through FULL, MIN and DIF ice level sensor settings. When selected, choice will flash (Fig. 46).
3. Press MODE SELECT button to change ice level sensor set point (Fig. 47).
4. Press LANE 1 button to increase ice level sensor set point and LANE 2 to decrease ice level sensor set point, (Fig. 48) to correspond to the drop-in dispenser ice level sensor settings listed in table above.
5. Press MODE SELECT to save new ice level sensor setting (Fig. 49).
6. Press LANE 1 to continue to navigate through and set the Full, Min, and Dif ice level sensor settings for lane 1 (Fig. 50).
7. Press MODE SELECT to navigate to lane 2 setup (Fig. 51).
8. Repeat steps 2 through 6 to complete changes to lane 2 ice level sensor settings.

Fig. 43

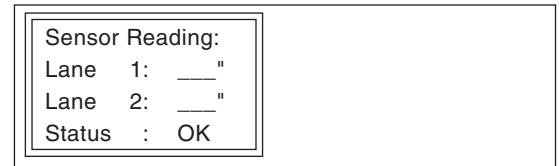

Fig. 44

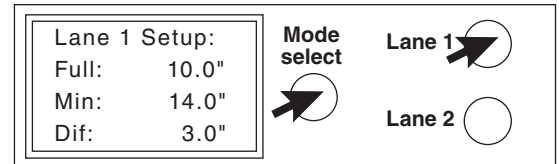

Fig. 45

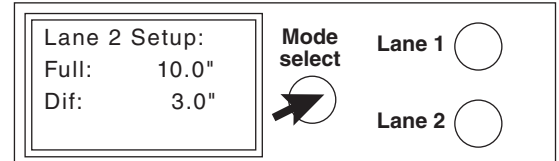

Fig. 46

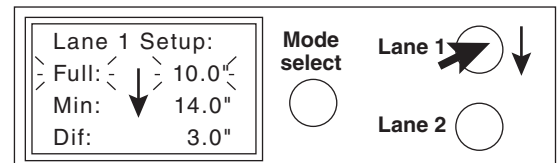

Fig. 47

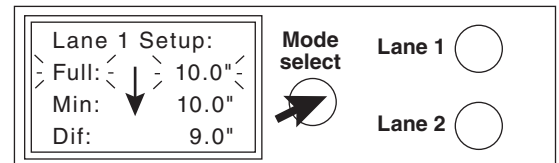

Fig. 48

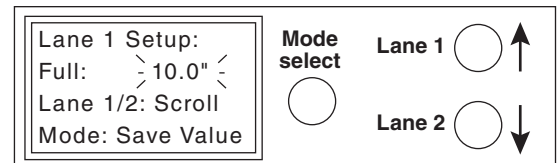

Fig. 49

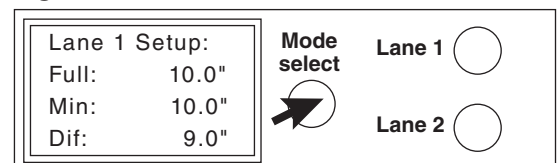

Fig. 50

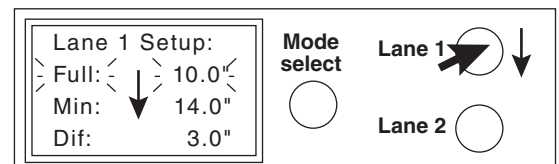
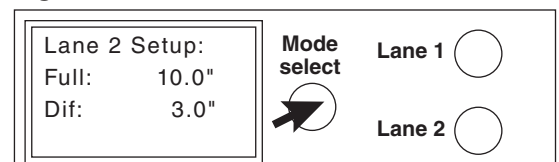

Fig. 51



# Troubleshooting

## Ice shortage with audible alarm

To silence audible alarm press any push buttons on the face of the control panel. Use the chart below to diagnose the cause.

Control Panel Error Message	Indicator or Possible Cause	Corrective Action
Ice machine LED is flashing and ICEMAKER ERROR message is displayed	• Signal cable between Horizon ice machine and diverter valve module is not properly engaged	• Check the signal cable connections
	• Horizon ice machine has shut off on a SERVICE error	• Troubleshoot Horizon ice machine
Lane 1 or lane 2 LED is flashing and SENSOR ERROR message is displayed	• Malfunctioning sensor	• Check supply and return dc voltage at sensor connections. Supply should read 12vdc between red and black wires. Return should read between .5 - 4.5 vdc between yellow and black wires.
		• Recycle power to sensor and see if error clears.
Lane 1 or lane 2 LED is flashing and SENSOR CONNECT ERROR message is displayed	• Sensor is disconnected from a signal cable	• Check sensor connections to cable
	• Signal cable is disconnected from diverter valve	• Check signal cable connection to diverter valve
Both lane 1 and lane 2 LEDs are alternately flashing and DIVERT ERROR message is displayed	• Both upper (lane 1) and lower (lane 2) magnetic positioning switches mounted to the gearmotor bracket inside the diverter valve are in closed or open position at the same time.	• Check both magnetic positioning sensors. One should be closed when it is engaged by the positioning disc, while the other should be open.  <b>Note:</b> To manually rotate the disc depress the gearmotor brake.
DIVERT TO L1 or DIVERT TO L2 message is displayed	• Divert valve fails to switch to another lane due to lane magnetic positioning switch not closing	• Check to be sure magnetic positioning switch is properly connected to the control board
		• Check the positioning switch for continuity while it is engaged by the positioning disc
	• Diverter valve fails to switch to another lane due to mechanical jamming inside the diverter valve	• Manually switch between lane 1 and lane 2 to free divert paddle
	• Mechanical linkage between the gearmotor and divert paddle is disconnected	• Check the linkage between the gearmotor and divert paddle

### Ice shortage without audible alarm

Use the chart below to diagnose the cause.

Control Panel Error Message	Indicator or Possible Cause	Corrective Action
No error message	<ul style="list-style-type: none"> <li>Signal cables and ice transport tubes are not connected to correct ice storage/ice dispenser (lane)</li> </ul>	<ul style="list-style-type: none"> <li>Check to be sure that signal cables and ice transport tubes are connected to correct lane</li> </ul>
No error message	<ul style="list-style-type: none"> <li>Ice level reading as displayed on control panel is significantly different from the actual distance between the ice and the sensor face</li> </ul>	<ul style="list-style-type: none"> <li>Recycle power to the diverter valve. Make sure to re-start the Horizon ice machine which will go into TIME DELAY mode</li> </ul>
No error message	<ul style="list-style-type: none"> <li>Horizon ice machine goes into TIME DELAY mode within a few minutes of start up of lane change</li> </ul>	<ul style="list-style-type: none"> <li>Manually switch ice to another lane and restart Horizon ice machine. Let ice machine produce ice for 5 to 8 minutes and manually switch ice back to the “troublesome” lane. See if “start-up” ice clears through</li> <li>If the above procedure does not work, investigate a potential ice lane restriction issue (i.e. transport tube, bulkhead fittings, sensor distribution unit, diverter valve)</li> <li>Check ice level set-points. Be sure they match factory settings or drop-in requirements shown in the Ice level set point section of this manual on page 24</li> </ul>

# Service Parts

Order parts online  
www.follettice.com

## Diverter valve module

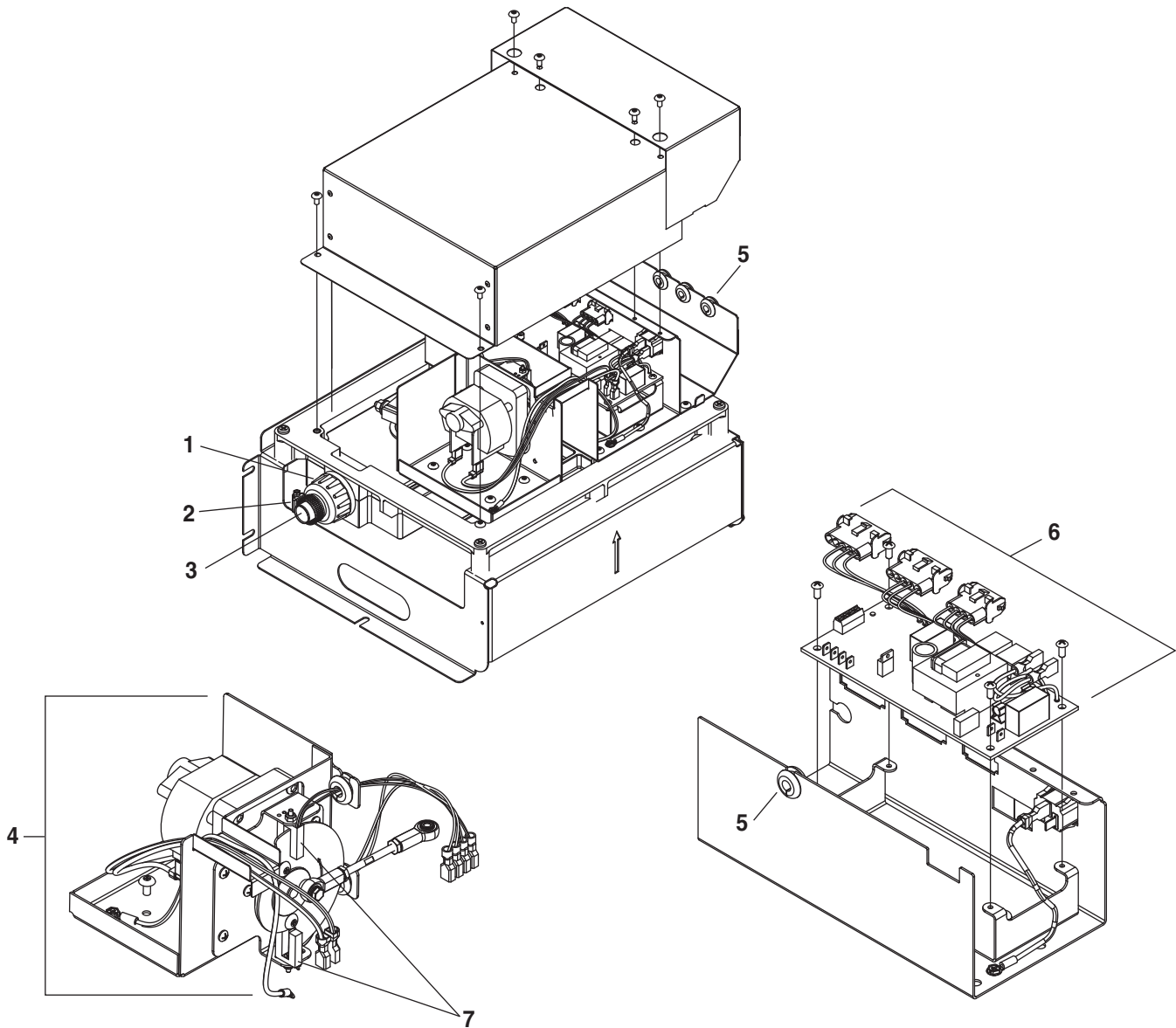

Reference #	Description	Part #
1	Nut	00145342
2	Clamp	500378
3	Coupling	00175141
4	Gearmotor assembly	00175166
5	Grommet	205577A
6	Main control board	00173955
7	Switch, magnetic (1)	00168096
Not shown	O-ring, ice tube	00144675
Not shown	Power cord	00153130
Not shown	Elbow, drain	00159178
Not shown	Hose, drain	206429

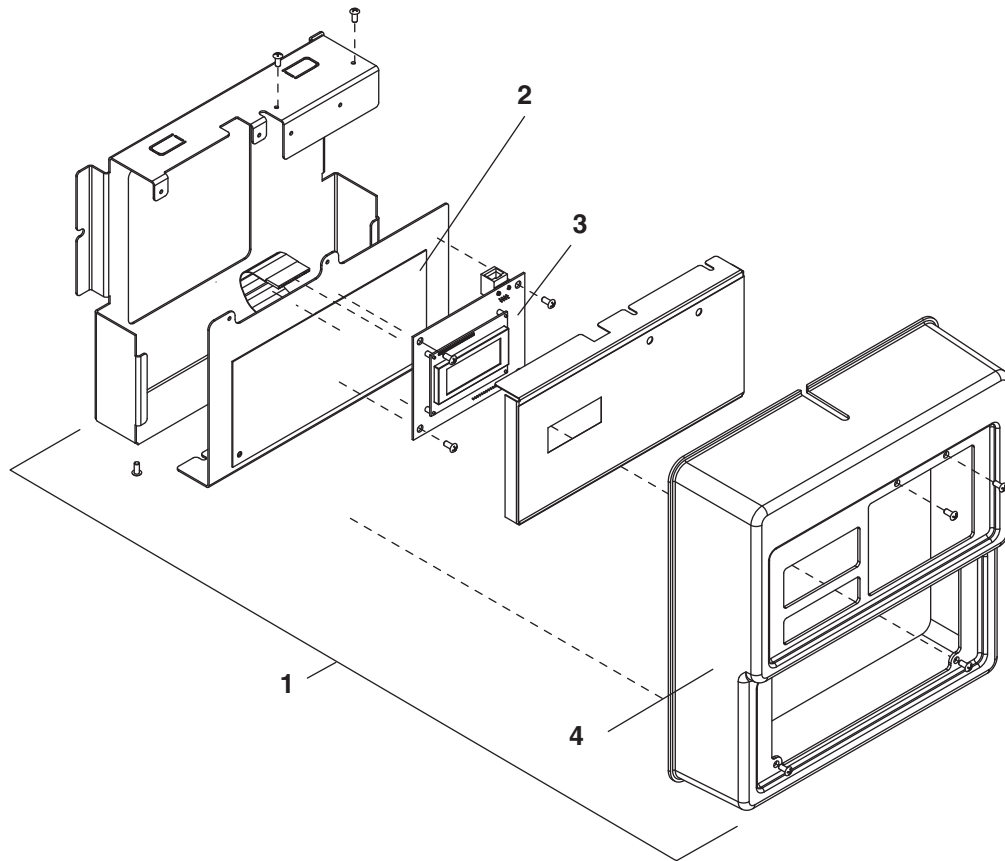

Reference #	Description	Part #
1	Control module (includes gray control cable)	00159350
2	Membrane switch	00172627
3	Control panel board	00172684
4	Control panel cover	00175133

# Sensor distribution unit

Order parts online  
www.follettice.com

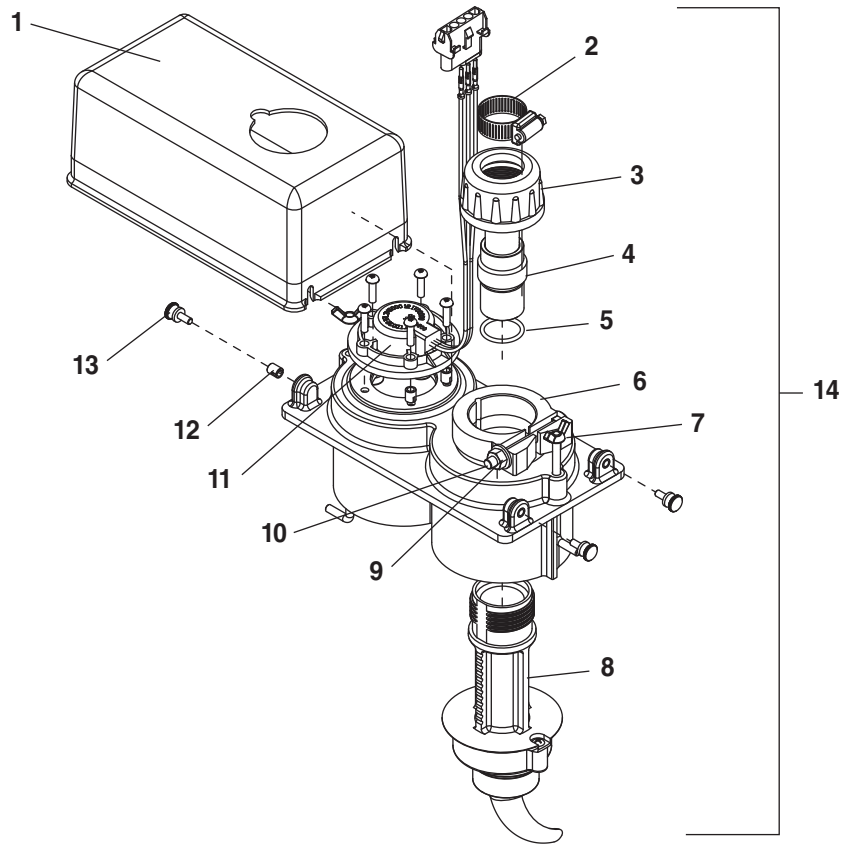

Reference #	Description	Part #
1	Cover	00155812
2	Clamp	500378
3	Nut	00145342
4	Coupling	00175141
5	O-ring	00145300
6	Clamp, positioning (includes nut and bolt)	00182451
7	Nut, wing and rod	00182469
8	Distribution unit	00146803
9	Nut, hex stainless steel 1/4-20	200864
10	Carriage screw, 1/4-20 2/5" long	00134312
11	Sensor, ultrasonic	00175174
12	Insert	00146738
13	Thumb screw	00150755
14	Sensor distribution assembly	00149377

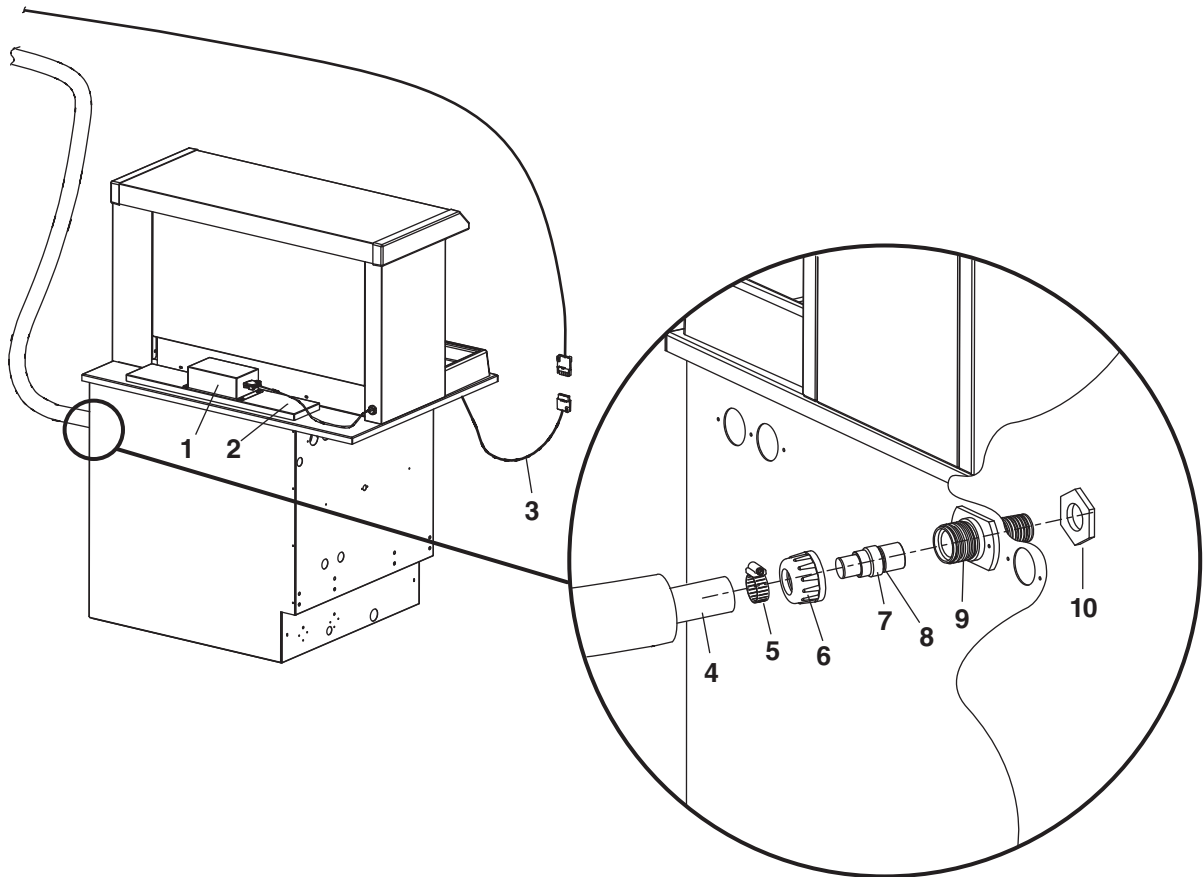

Reference #	Description	Part #
1	Cover, 155 sensor	00182550
2	Lid, rear, 155 sensor	00182568
3	Vision sensor cable	00167098
4	Polywire tube, insulated	see page 35
5	Clamp, hose	500378
6	Nut	00145342
7	Coupling (includes 00145300)	00175141
8	O-ring	00145300
9	Bulkhead fitting	00155747
10	Nut, bulkhead fitting	00155788

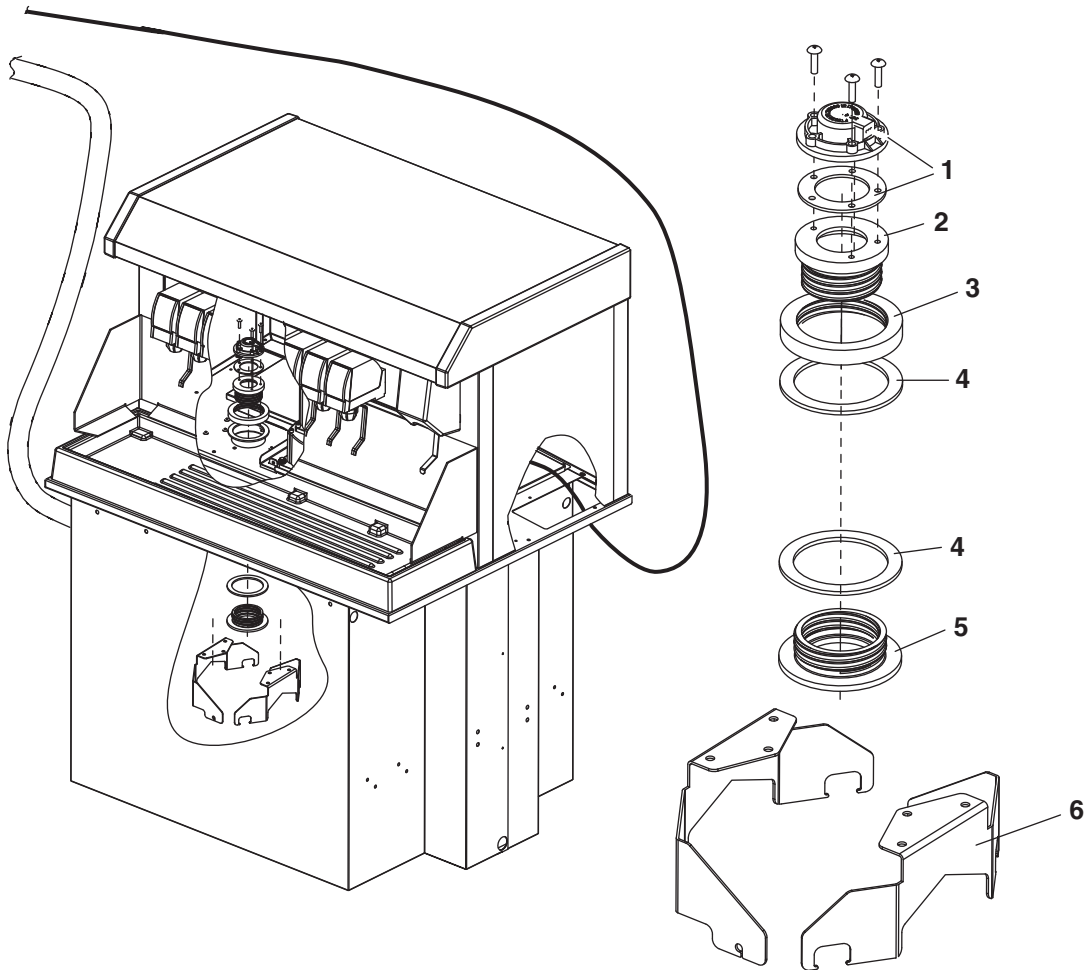

Reference #	Description	Part #
1	Sensor, ultrasonic, service	00175174
2	Tube, sensor mount	00164152
3	Locking ring, coupling	00164132
4	Gasket, coupling	00126532
5	Coupling, sensor mount	00164145
6	Bracket, ice tube	00175208

## Cables

Order parts online  
[www.follettice.com](http://www.follettice.com)

Reference #	Description	Part #
Not shown	Cable, control panel to diverter valve, 30' (9m)	00163212
Not shown	Cable, diverter valve lane sensor, 10' (3m)	00170449
Not shown	Cable, diverter valve lane sensor, 25' (7.6m)	00170456
Not shown	Cable, diverter valve lane sensor, 50' (15.2m)	00153106
Not shown	Cable, diverter valve lane sensor, 75' (22.9m)	00170464
Not shown	Cable, Horizon to diverter valve, 20' (6m)	00188169
Not shown	Cable, Horizon board interface	00187526
Not shown	Ice transport tube, 10'*	00171280
Not shown	Ice transport tube, 20'*	00171298
Not shown	Ice transport tube, by the foot*	00174896
Not shown	Shuttle assy., heavy spring	00185140

\* All ice transport tube includes insulation, shipped loose.

## Ice Machine Retrofit Kits

Reference #	Description	Part #
Not shown	HCC prior to C43650	00185181
Not shown	HCD prior to C43650	00185272
Not shown	Models after C43650	00191965





Horizon, Ice Manager, SafeCLEAN, Sani-Sponge, RIDE and Vision are trademarks of Follett Corporation.  
Follett and Chewblet are registered trademarks of Follett Corporation, registered in the US.

---



801 Church Lane • Easton, PA 18040, USA  
Toll free (877) 612-5086 • +1 (610) 252-7301  
[www.follettice.com](http://www.follettice.com)

00195776R05  
2/13