

Maestro Plus™ Ice Machine with RIDE™ Technology Installation Instructions for Harmony™

MCD425A/W HS, MCE425A HS, MCC425A HS
(See model number configurator on page 2 for details.)

Order parts online
www.follettice.com

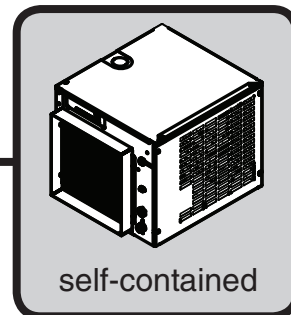

**Maestro Plus ice machines with RIDE technology
fit most countertop dispensers manufactured by
Cornelius • Lancer • SerVend**

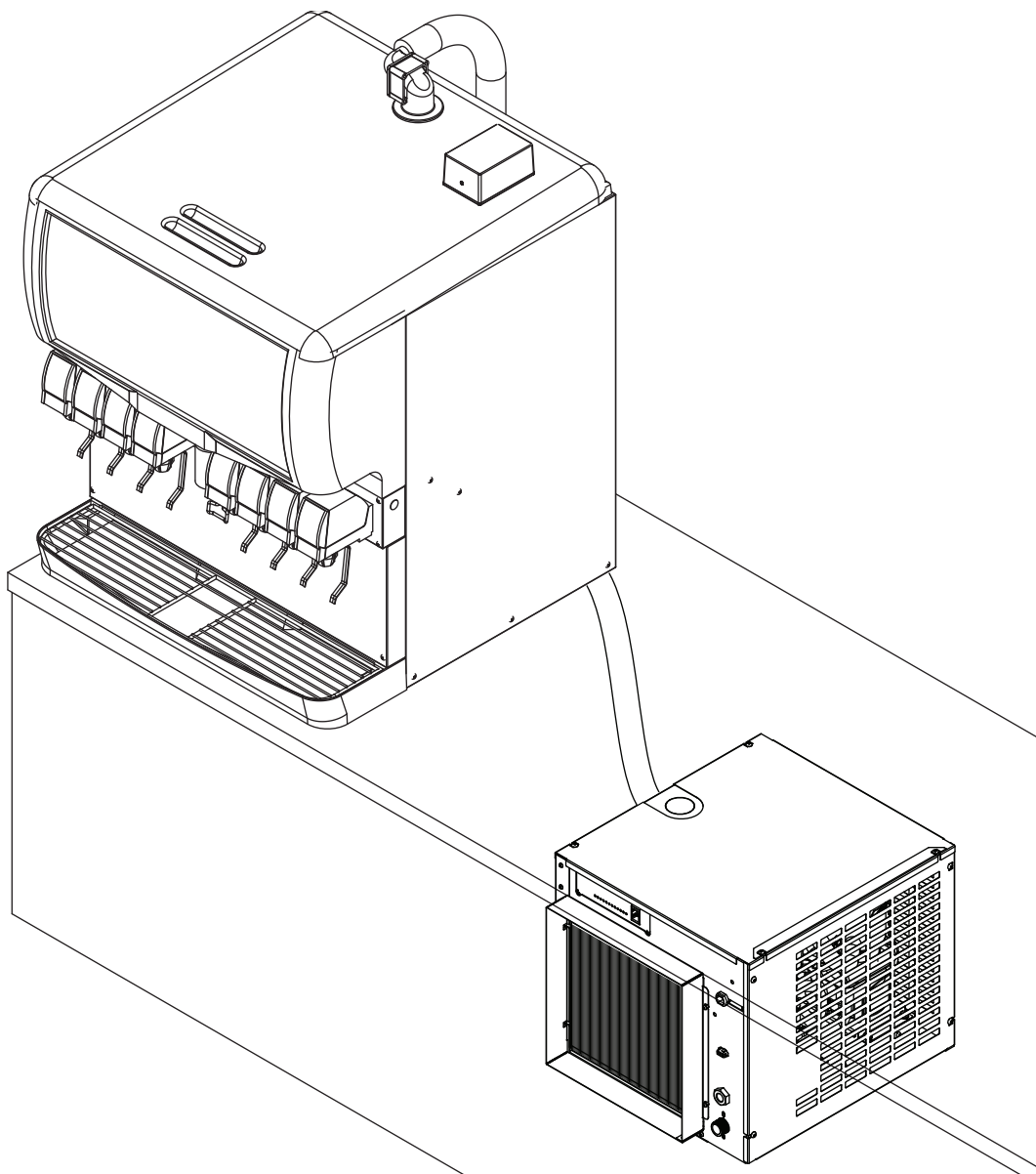

Chewblet® Ice Machine Model Number Configurations

MC C 425 A V S

Machine	Voltage	Series	Condenser	Application	Configuration
MC Maestro Plus Chewblet (425 Series)	C 208-230/60/1 <i>Self-contained</i>	425 up to 454 lbs (206kg)	A Air-cooled, self-contained	V Vision™	S RIDE® (RIDE remote ice delivery equipment)
	D 115/60/1 <i>Self-contained</i>		W Water-cooled, self-contained	H Harmony™	
	E 230/50/1 <i>Self-contained</i>			B Ice storage bin	
MF Maestro Plus™ Flake				J Drop-in	
P Replacement					
R Symphony Plus RIDE Ice Machine					

CAUTION!

- This appliance should be connected by a qualified person in accordance with application codes.
- If the supply cord is damaged, it must be replaced by the manufacturer, its service agent or similarly qualified persons in order to avoid a hazard.
- Connect to potable water supply only.
- This appliance can be used by children aged 8 years and above and persons with reduced physical, sensory, or mental capabilities, or lack of experience and knowledge if they have been given supervision or instruction concerning use of the appliance in a safe way and understand the hazards involved. Children should be supervised to ensure that they do not play with the appliance.
- This appliance is intended to be used for household and similar applications such as staff kitchen areas in shops, offices and other working environments; farm houses and by clients in hotels, motels and other residential type environments; bed and breakfast type environments; catering and similar non-retail applications.
- **WARNING!** To avoid a hazard due to instability of the appliance, it must be fixed in accordance with the instructions.

Contents

- Unpack 4**
 - Unpack Ice Machine 4
- Site Preparation 5**
 - Installation site requirements 5
- Dispenser Top Preparation 6**
 - Top Preparation 6
 - Mount thermostat box 6
 - Install shuttle actuator and bracket 7
 - Route thermostat 7
- Mount Ice Machine 8**
 - Ice machine in cabinet 8
- External Connections 10**
 - Air-cooled ice machines only 10
 - Water-cooled ice machines only 10
 - Bin thermostat Cable 10
- Dispenser Agitation Adjustment 11**
 - Agitation adjustments - CORNELIUS 11
 - Agitation adjustments – LANCER 4500 SERIES 11
 - Agitation adjustments – LANCER FS SERIES 12
 - Agitation adjustments – SERVEND 12
 - Dispenser diverter plate overview – CORNELIUS, ED, DF AND DB SERIES
(installation on next page) 13
 - Dispenser diverter plate installation – CORNELIUS, ED, DF AND DB SERIES 14
- Transport tube installation 15**
 - General requirements 15
 - Procedure 15
- RIDE model ice machine start up procedure 16**
 - Before turning on power 16
 - After turning on power 16

1. Unpack

Carefully unpack and inspect the contents of your Follett ice machine.

1.1 Unpack Ice Machine

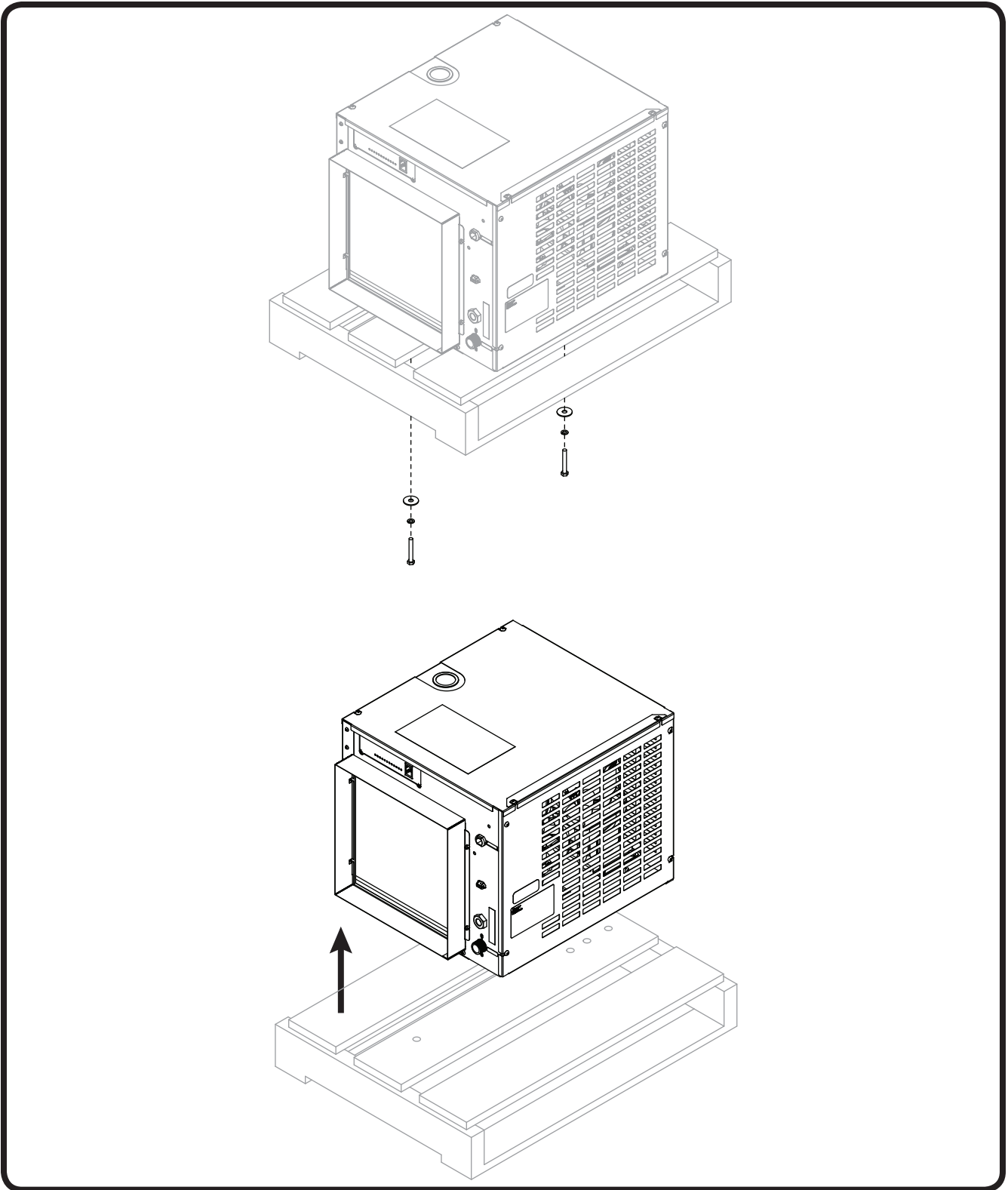

2. Site Preparation

Provide drainage, potable water supply and electrical power to within 6 feet (2m) of ice machine in accordance with local and national codes. Outdoor installation is not recommended and will void warranty.

2.1 Installation site requirements

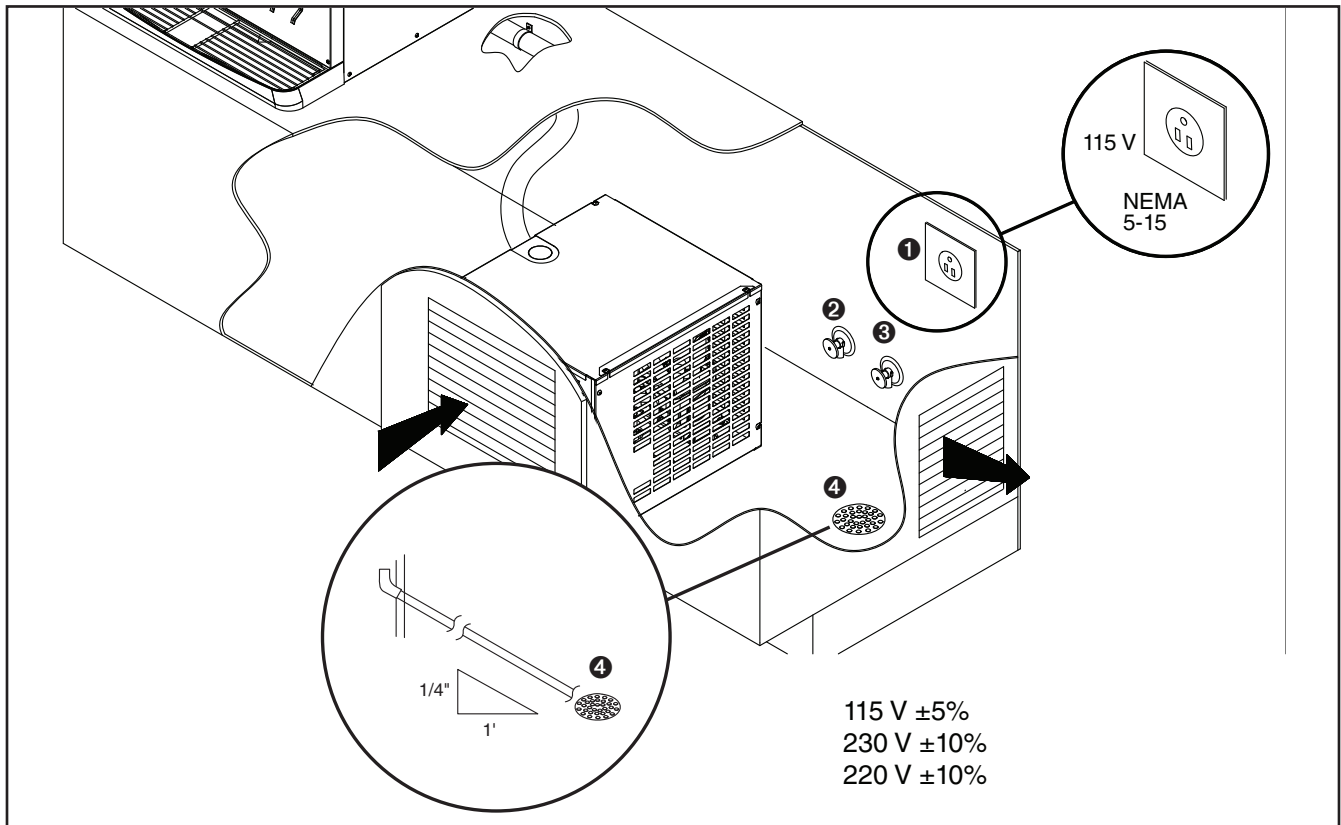

Electrical ❶



WARNING!

- This appliance should be connected by a qualified person in accordance with application codes.
- If the supply cord is damaged, it must be replaced by the manufacturer, its service agent or similarly qualified persons in order to avoid a hazard.

MCD425(A/W)HS 115/60/1 (115 V ±10%) 15A breaker
(MCD requires a 15A dedicated circuit)

MCE425(A)HS (230/50/1 - 5.5A (full load)
(MCE425A/W requires a dedicated circuit, 1.50 mm² wire)

MCC425(A)HS (220/60/1 - 5.5A (full load)
(MCE425A/W requires a dedicated circuit)

Potable Water Supply ❷

10 psi to 70 psi (69 kpa to 483kpa)

45 F to 90 F (7 C to 32 C)

Condenser water supply for water-cooled systems ❸

10 psi min.; 125 psi max. (69 kpa min.; 862 kpa max.)

20 F to 90 F (-7 C to 32 C)

0.5 gallons (1.9 liters) per minute

Drain ❹

The drain line from the ice machine must have at least 1/4 in. per foot (6,4 mm/0,3 m) pitch

3. Dispenser Top Preparation

Prepare the dispenser.

Note: The instructions below only apply to 22" & 30" wide dispensers. 44" wide dispenser instructions may be found with the top kit.

3.1 Top Preparation

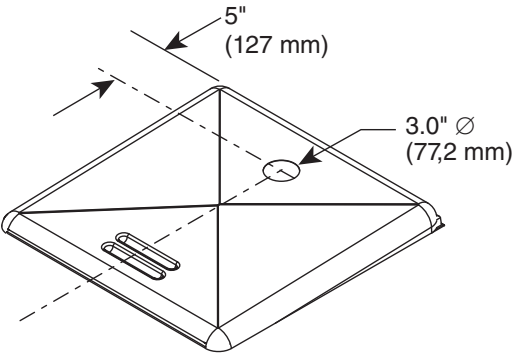
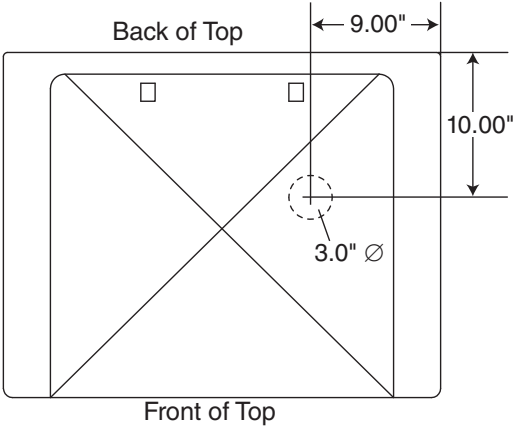
Standard (Cornelius, Lancer, or Servend)	Lancer Sensation and Touchpoint
	
<ul style="list-style-type: none">▪ Locate hole position 5" (127 mm) from back of dispenser top.	<ul style="list-style-type: none">▪ Locate hole position 10" (254 mm) from back and 9" (229 mm) from right of dispenser top.

3.2 Mount thermostat box

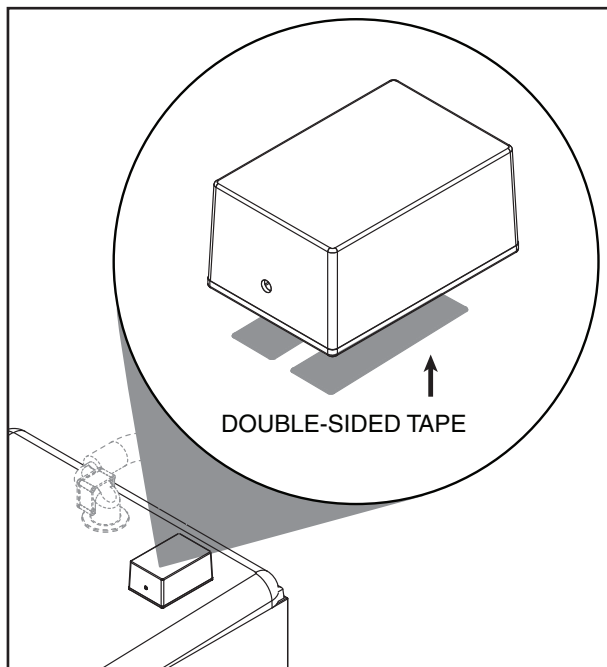

- Apply double-sided tape to bottom of thermostat box and mount box on bin.

3.3 Install shuttle actuator and bracket

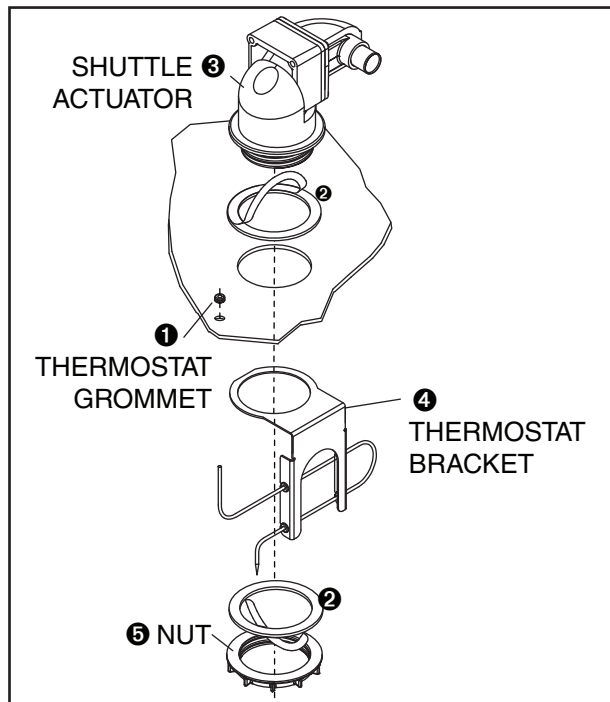

- Install thermostat grommet ①.
- Remove protective tape and apply gaskets ② to shuttle actuator and nut.
- Place shuttle actuator in hole ③.
- Install thermostat bracket ④ and nut ⑤. Ensure that nut captures the thermostat bracket, then hand tighten.

3.4 Route thermostat

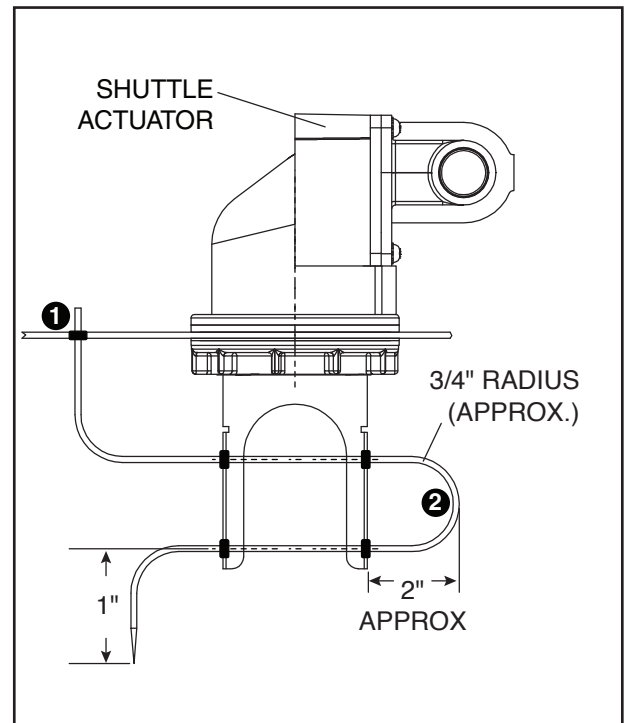

- Route thermostat through grommet and into bin ①.
- Secure thermostat in bracket ②.

4. Mount Ice Machine

Mounting options: Cabinet, Wall, Stand

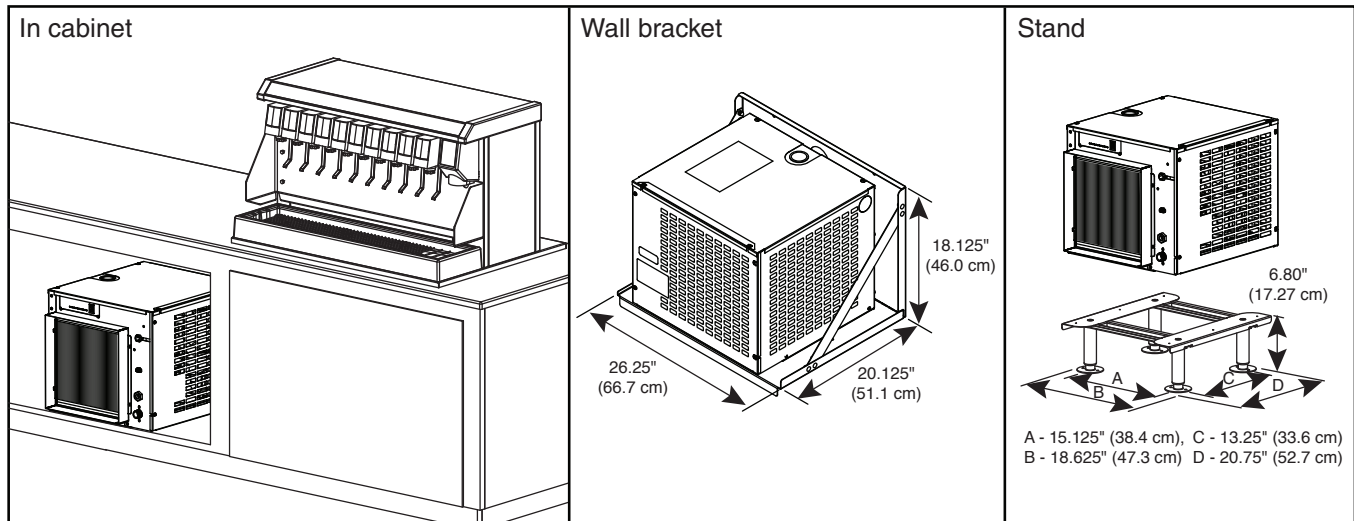

4.1 Ice machine in cabinet

Maestro ice machines can be installed undercounter/in-cabinet to fill bins or dispensers using RIDE technology. Care must be taken to ensure proper cabinet venting to avoid recirculation of hot air. Improper venting can cause ice machine outages.

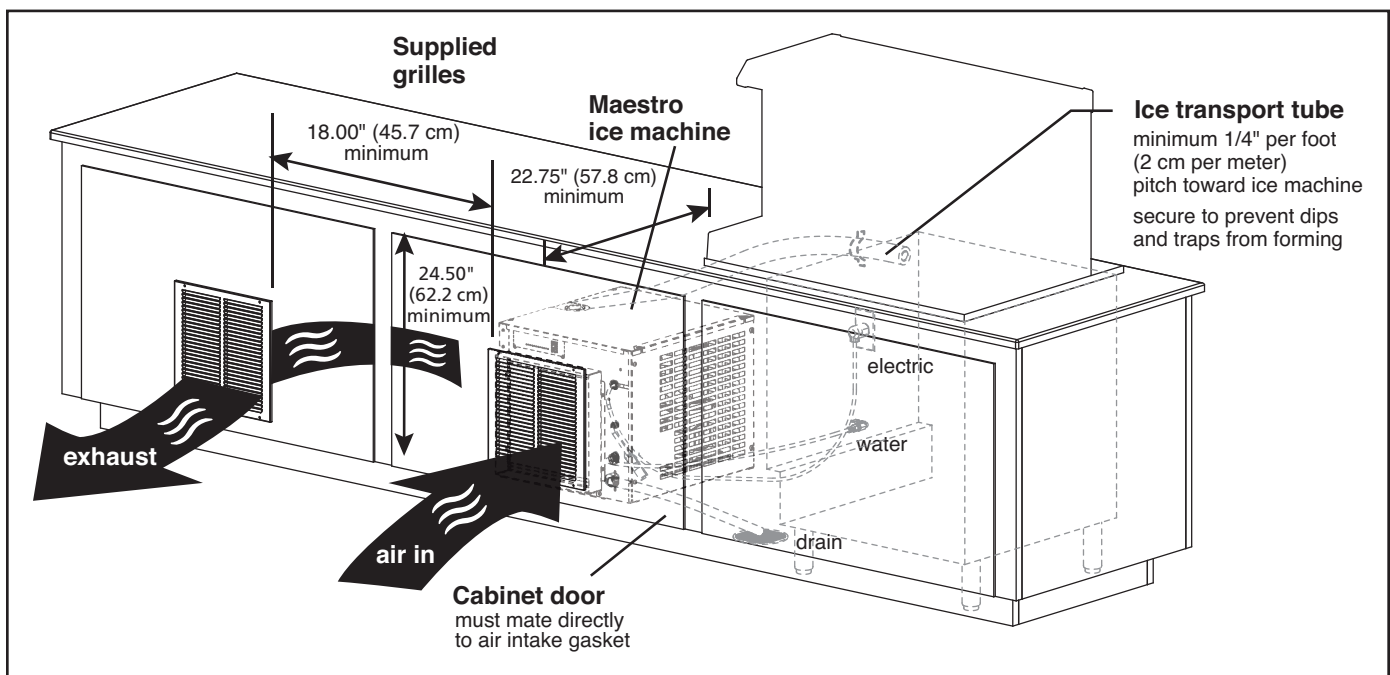

- The supplied exhaust grille must be located at least 18" (46 cm) from the supplied air intake grille (exhaust air must not recirculate with intake air).
 - Cabinet interior must be open to allow for unrestricted exhaust air flow.
 - Ice transport tube needs minimum 1/4" per foot (2 cm per meter) pitch toward ice machine and should be secured to prevent dips and traps from forming.
 - Cabinet door must mate directly to air intake gasket.
 - Cabinet interior must provide a minimum clear space of 22.75" deep (57.8 cm) by 29" high (74 cm).
- Note: 25.75" (65.4 cm) required for plug removal if receptacle located directly behind unit.**
- Cutout for supplied grilles must meet minimum size requirements shown above.
 - Utilities should be conveniently located as shown.

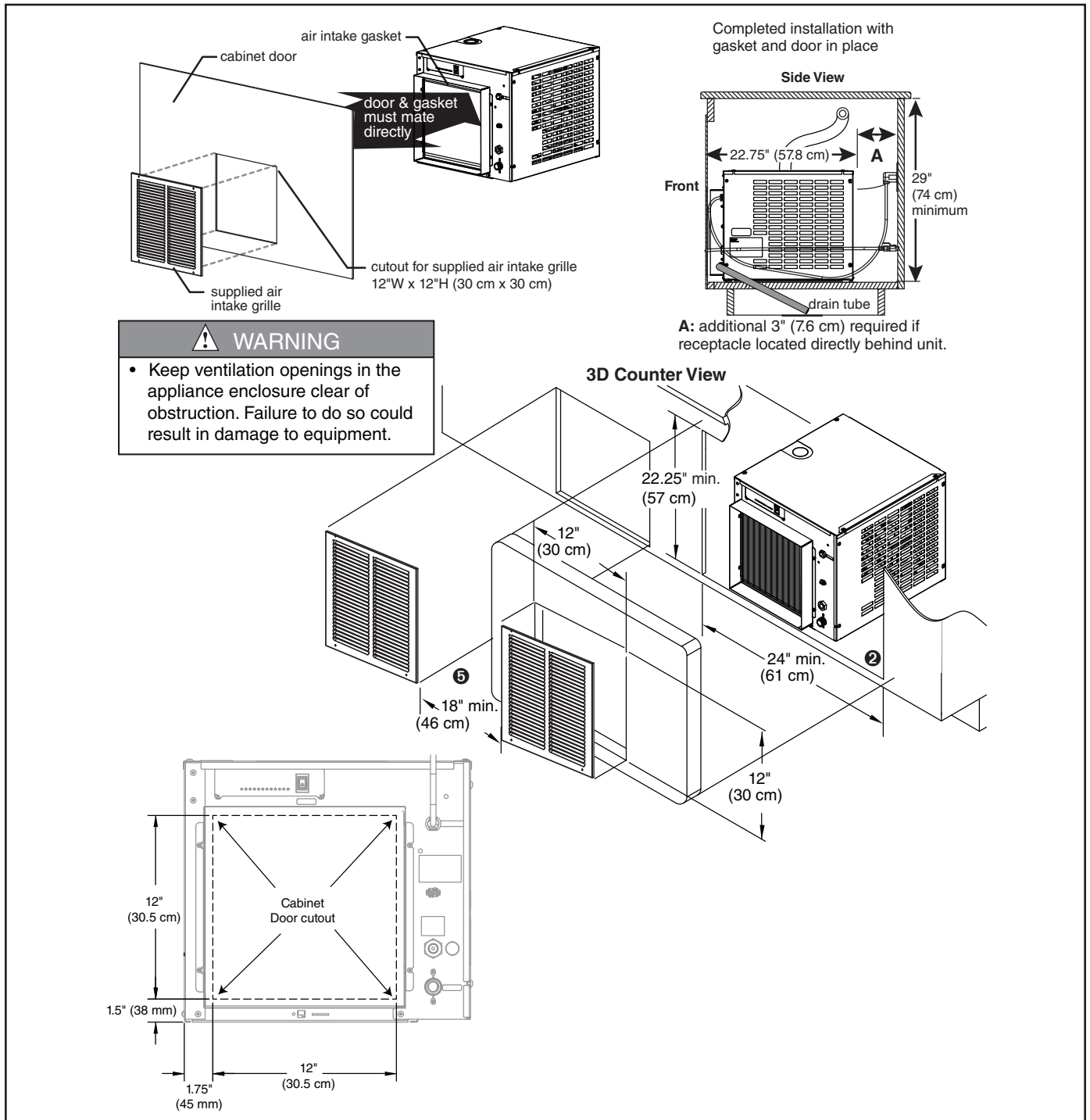

WARNING

- Keep ventilation openings in the appliance enclosure clear of obstruction. Failure to do so could result in damage to equipment.

- Intake and Exhaust Grille Placement: air-cooled models only
 - Position the intake grille cut out in the access panel/door
- Note: Ice machine must be aligned with cut out and inside of access panel to provide a tight seal and prevent recirculation of hot exhaust air.**
- Left edge of cutout should be 1.75" (4.5 cm) from the left side of the ice machine ③

- Bottom edge of cutout should be 1" (2.5 cm) from the bottom of the ice machine ④
- Position supplied exhaust grille at least 18" (46 cm) away from intake grille ⑤. Where possible, install exhaust grille to the rear or side of the base cabinet.
- If not using supplied grille, air circulation requirements must be met: 160 sq. in (1032 sq cm) intake/exhaust air.

5. External Connections

5.1 Air-cooled ice machines only

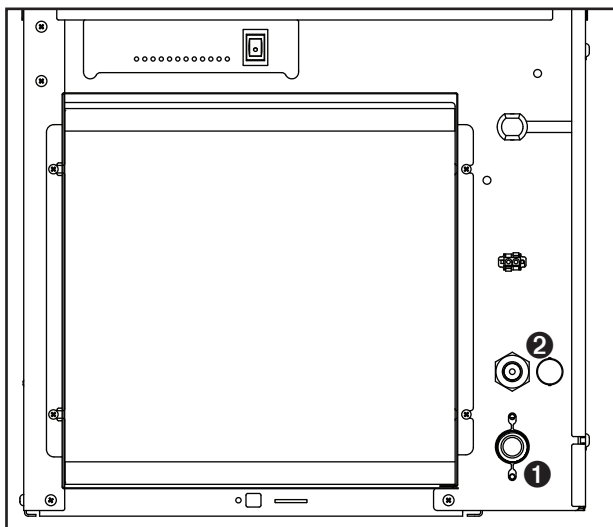

- Install drain line **1** (3/4" MPT).
The rigid drain line from the ice machine must have at least 1/4" per foot (6,4 mm/0,3 m) pitch.
- Install ice machine potable water supply **2** (3/8" FPT).

Note: Follett recommends a Follett water filter system be installed in the ice machine inlet water line (standard capacity #00130299, high capacity #00978957, carbonless high capacity #01050442).

5.2 Water-cooled ice machines only

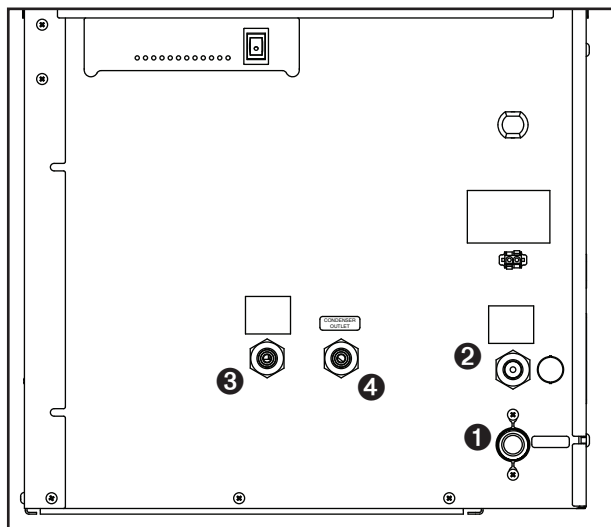

- Install drain line **1** (3/4" MPT).
The rigid drain line from the ice machine must have at least 1/4" per foot (6,4 mm/0,3 m) pitch.
- Install ice machine potable water supply **2** (3/8" FPT).

Note: Follett recommends a Follett water filter system be installed in the ice machine inlet water line (standard capacity #00130299, high capacity #00978957, carbonless high capacity #01050442).

- Connect cooling water supply **3** and return **4** (3/8" FPT).

5.3 Bin Thermostat Cable

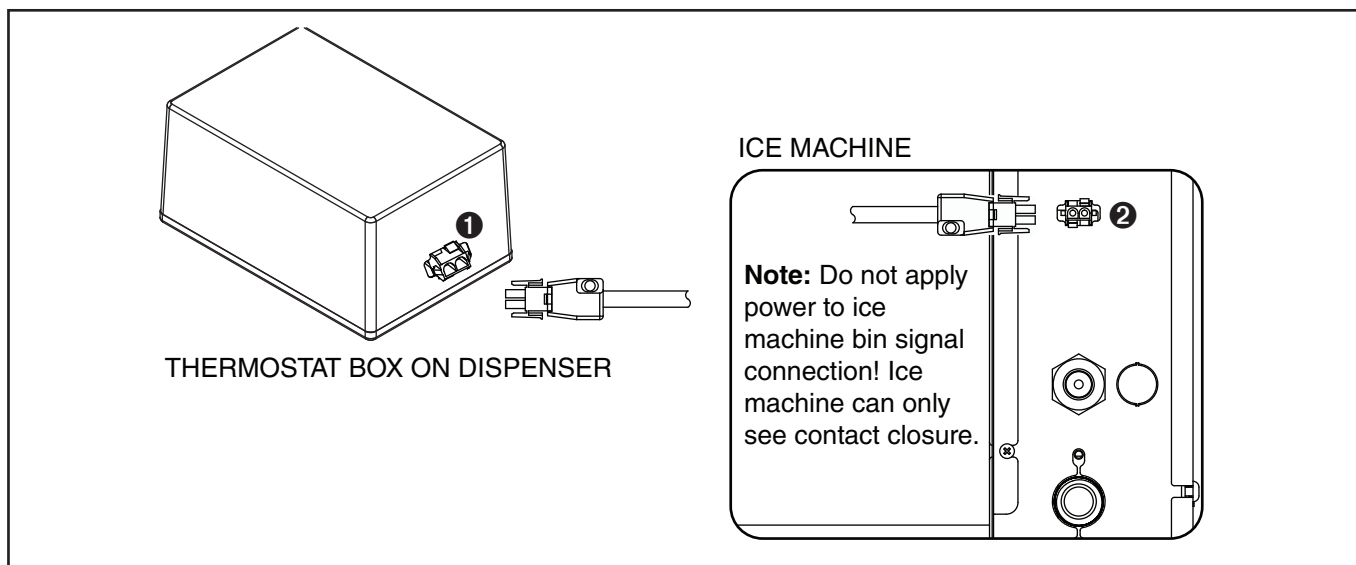

- Connect 2-pin bin thermostat cable at thermostat box on dispenser and at front of ice machine.

6. Dispenser Agitation Adjustment

6.1 Agitation adjustments - CORNELIUS

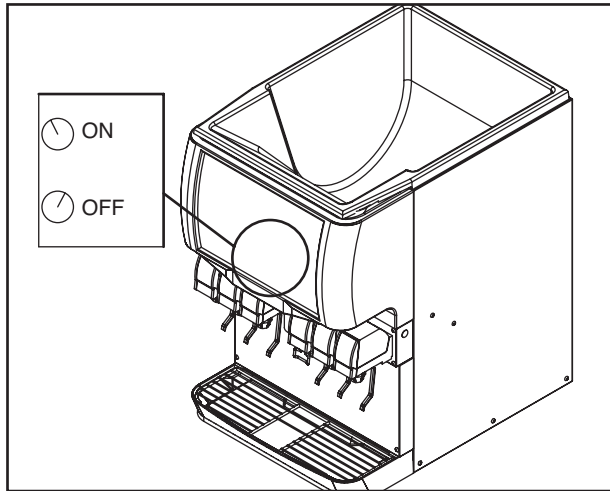

Cornelius models ED, DB, DF, IDC and Flavor Fusion

- Adjust the agitation tier located on the Cornelius PC board to 1 second on, 1 hour off.

Note: see Cornelius manual for more information.

6.2 Agitation adjustments – LANCER 4500 SERIES

AGITATION TIME

SWITCH NUMBER	1 S	4 S	4 S	4 S
3	O	O	X	X
4	O	X	O	X

AGITATION FREQUENCY

SWITCH NUMBER	NONE	10 MIN	20 MIN	30 MIN	40 MIN	50 MIN	60 MIN	70 MIN	80 MIN	90 MIN	100 MIN	110 MIN	120 MIN	130 MIN	140 MIN	150 MIN
5	O	O	O	O	O	O	O	X	X	X	X	X	X	X	X	X
6	O	O	O	O	X	X	X	X	O	O	O	O	X	X	X	X
7	O	O	X	X	O	O	X	X	O	O	X	X	O	O	X	X
8	O	X	O	X	O	X	O	X	O	X	O	X	O	X	O	X

Legend:
X = ON
O = OFF

Lancer 4500 series only

Adjust the agitation time to 1 second, and the agitation frequency to 150 minutes. See Lancer manual for more information.

6.3 Agitation adjustments – LANCER Sensation and Touchpoint

No agitation adjustment required.

6.4 Agitation adjustments – LANCER FS SERIES

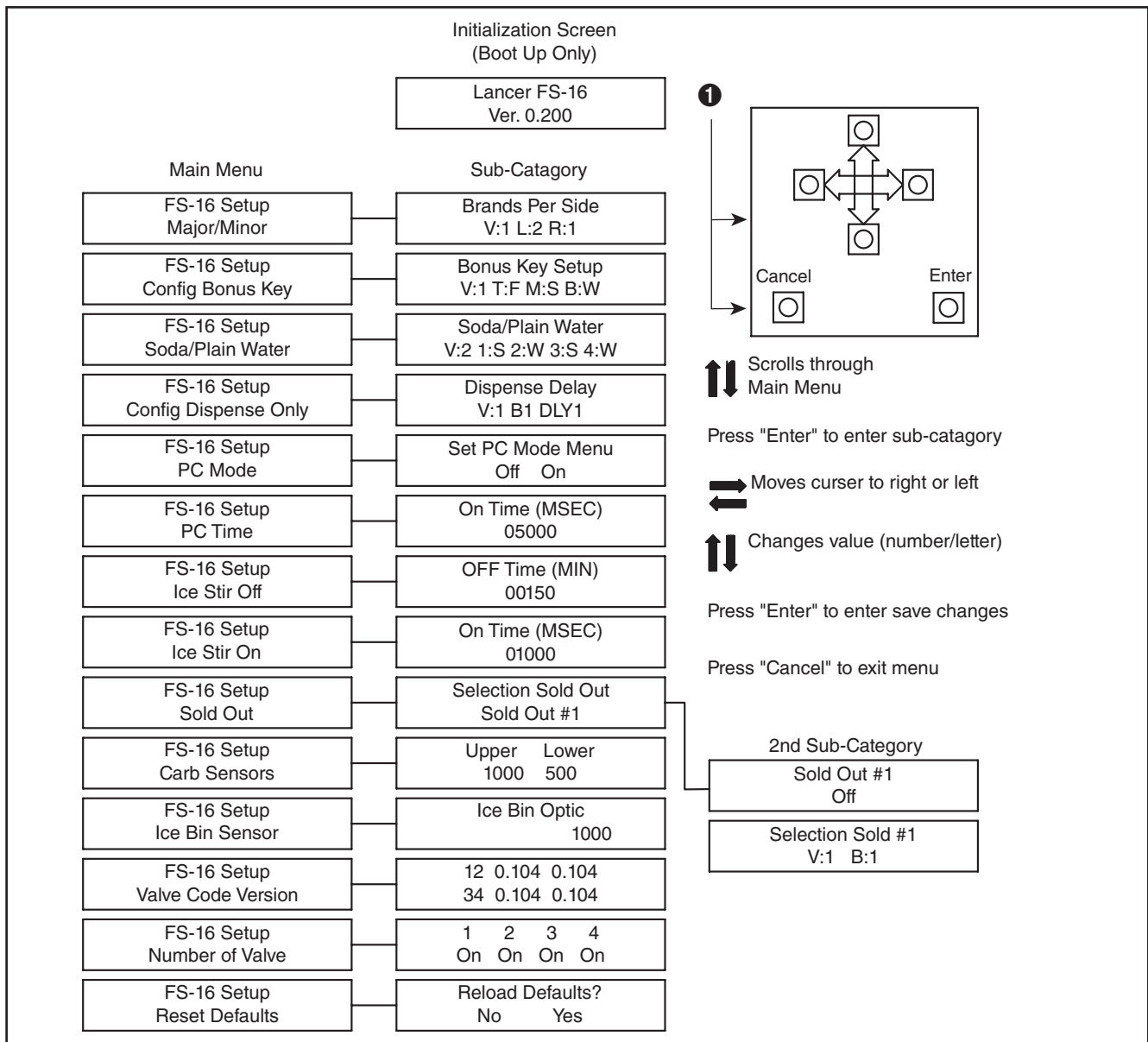

Lancer 4500 series only

- Hold down "cancel" and "left button" to get to hidden menu ①.
- Type in code 6655.
- Type in 150 minutes of off time and 1000 milliseconds (1 second of time) as the preferred setting.

Note: see Lancer manual for more information.

6.5 Agitation adjustments – SERVEND

Lancer 4500 series only

No agitation adjustment required.

6.6 Dispenser diverter plate overview – CORNELIUS, ED, DF AND DB SERIES (installation on next page)

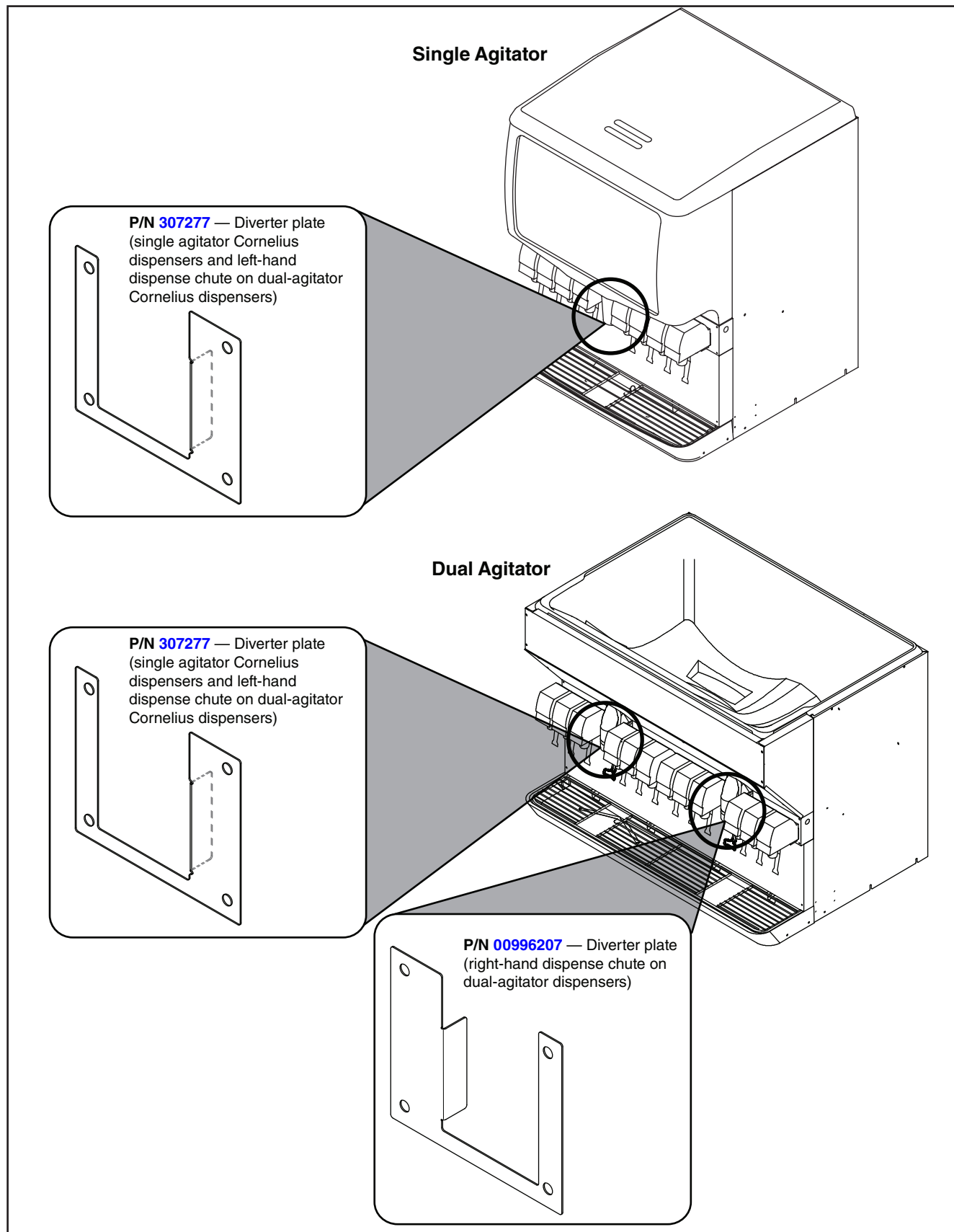

6.7 Dispenser diverter plate installation – CORNELIUS, ED, DF AND DB SERIES

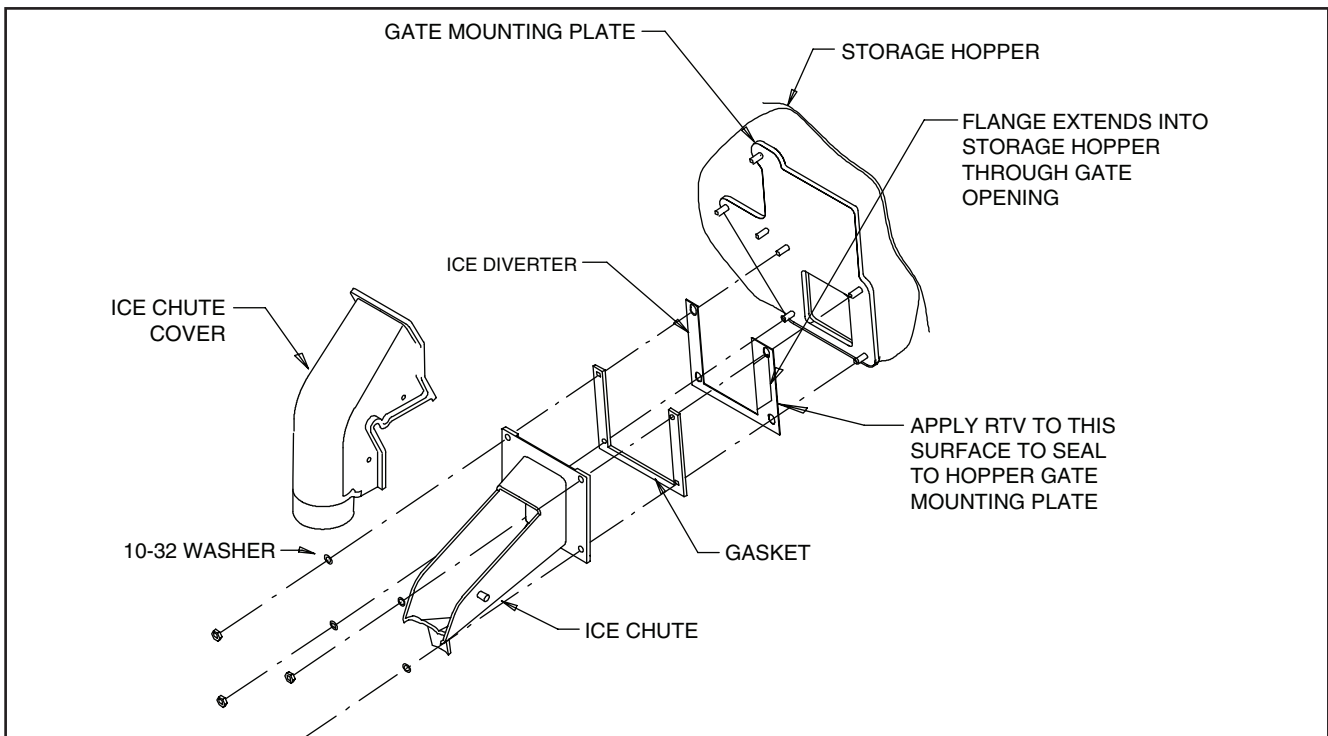

CORNELIUS ED, DF AND DB series only

These dispensers require the installation of an ice diverter at the dispenser opening:

- Disassemble chute assembly
- Discard factory restrictor plate
- Replace with alternate diverter plate (supplied)

Cornelius IDC and Flavor Fusion

These dispensers require modifications for compatibility with Chewblet ice. Agitation times must be set to 1 second ON, 1 hour OFF and the ice restrictor plate must be adjusted to the fully open position. See your beverage supplier for these modifications.

Note: IDC and Flavor Fusion must be nugget-ready. Please contact beverage supplier for installation of ice slide.

7. Transport tube installation

Incorrect ice transport tube installation can result in wet ice and dispensing problems. Follow guidelines below to ensure correct installation. Call factory for assistance if you are unable to meet these requirements.

7.1 General requirements

- Maximum length of tube run – 20 ft (6 m). Factory approval required for longer runs.
- Run tube without dips.
- One continuous length of tube; no splices.
- Minimum radius of bends in tube – 6" (15.3 cm) inside radius.
- Maximum number of bends – 6.
- Insulation on entire run of ice tube.

7.2 Procedure

1. Install supplied insulation on entire length of tube.
2. Remove ice machine top panel.
3. Select side, rear or top knockout in ice machine cabinet for tube entrance and install bushing.
4. Run insulated tube without dips between dispenser and ice machine and secure in place.
5. Slide end of transport tube and insulation through bushing and run to nozzle.
6. Cut tube to that length.
7. Pull insulation back and slip supplied hose clamp over end of transport tube.
8. Heat end of transport tube in cup of 160 F (71 C) hot water to soften ❶ and spread with pliers ❷ before making connection to ease assembly.
9. Push transport tube onto nozzle ❸.
10. Position clamp behind lip on nozzle and tighten clamp.

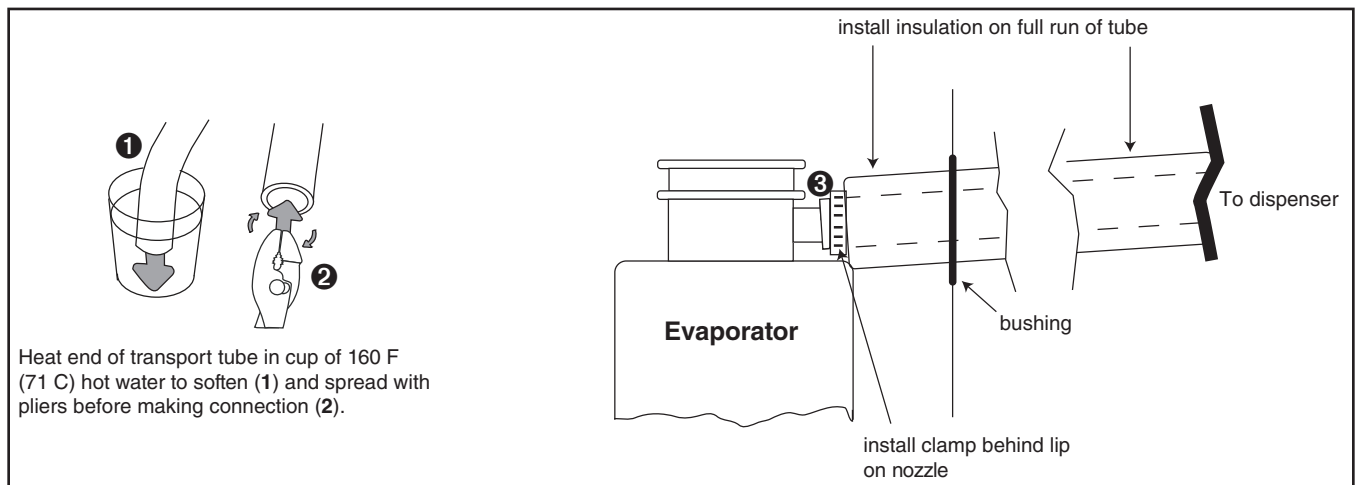

8. RIDE model ice machine start up procedure

The start-up procedure below is intended to ensure that ice machine is operating properly after installation has been made. Check each item listed and call factory immediately for assistance if you experience problems with unit.

NOTICE!

- Ice machine **MUST** be sanitized prior to operation!
- Consult Operation and Service Manual provided with ice machine for sanitizing instructions.

8.1 Before turning on power

1. Turn on water to ice machine.
2. Check that hose clamp securely holds ice transport tube on evaporator port.

8.2 After turning on power

1. Turn on power to ice machine and confirm that gearmotor, fan motor and compressor start immediately.
2. Check that ice begins to enter dispenser bin area within approximately 10 minutes.
3. Put ice against bin level thermostat in dispenser bin and check that compressor and gear motor shut down immediately after thermostat opens. Fan will continue to run for an additional 10 minutes.
4. Check that ice machine comes back on in approximately 20 minutes (bin signal must be present).

Maestro Plus and Harmony are trademarks of Follett LLC.

Follett, Chewblet and RIDE are registered trademarks of Follett LLC, registered in the US.