

Maestro Plus™ Ice Machine with RIDE™ Technology Installation Instructions for Vision™

MCD425A/W VS, MCE425A/W VS, MCC425A/WVS
(See model number configurator on page 2 for details.)

Order parts online
www.follettice.com

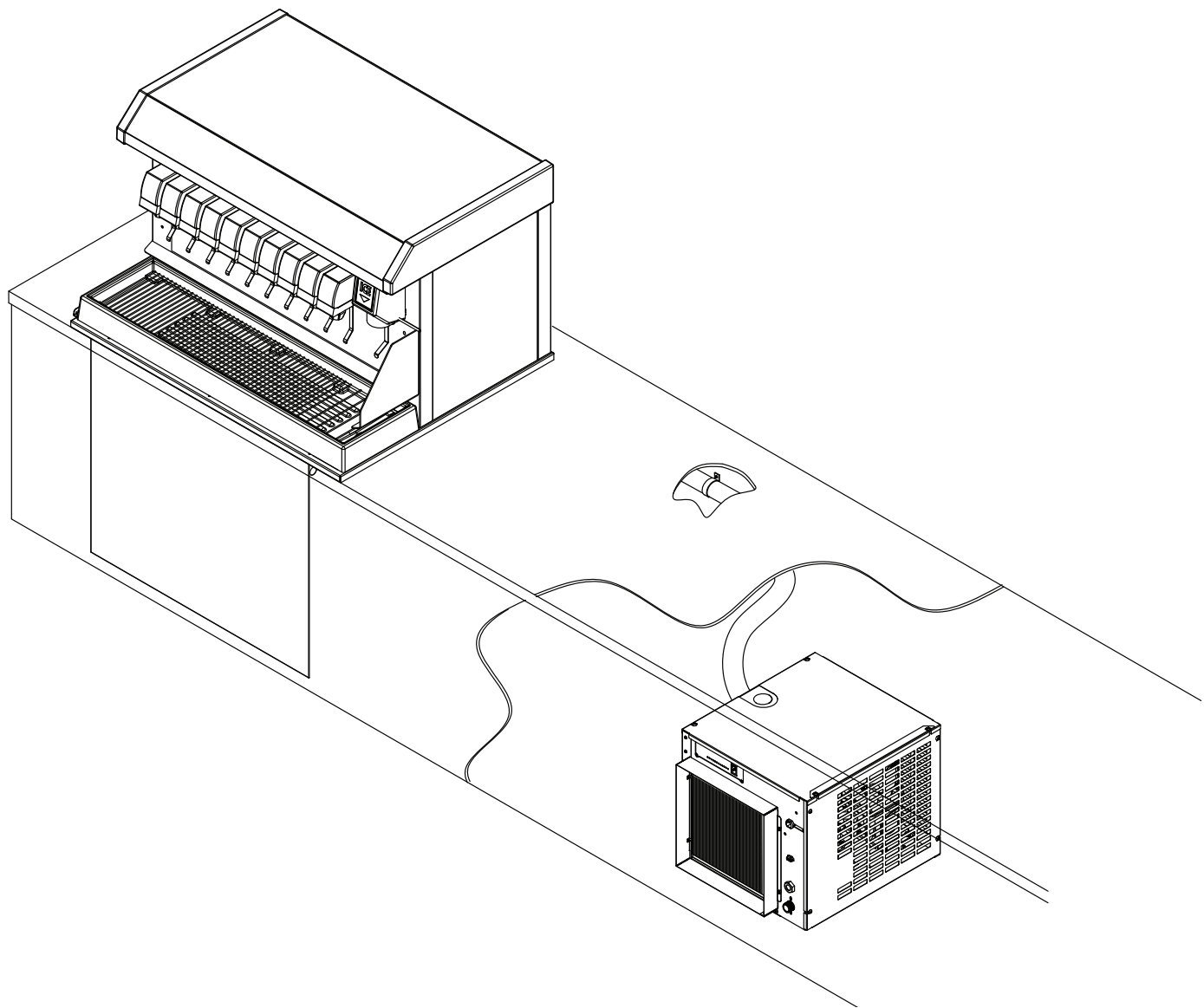
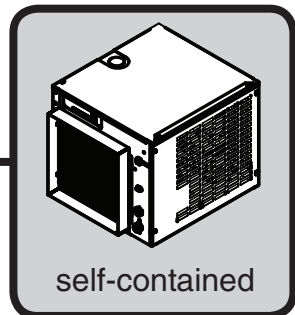

Chewblet® Ice Machine Model Number Configurations

Machine	Voltage	Series	Condenser	Application	Configuration
MC Maestro Plus Chewblet (425 Series) MF Maestro Plus™ Flake P Replacement R Symphony Pus RIDE Ice Machine	C 208-230/60/1 <i>Self-contained</i> D 115/60/1 <i>Self-contained</i> E 230/50/1 <i>Self-contained</i>	425 up to 454 lbs (206kg)	A Air-cooled, self-contained W Water-cooled, self-contained	V Vision™ H Harmony™ B Ice storage bin J Drop-in	S RIDE® (RIDE remote ice delivery equipment) T Top-mount

CAUTION!

- This appliance should be connected by a qualified person in accordance with application codes.
- If the supply cord is damaged, it must be replaced by the manufacturer, its service agent or similarly qualified persons in order to avoid a hazard.
- Connect to potable water supply only.
- This appliance can be used by children aged 8 years and above and persons with reduced physical, sensory, or mental capabilities, or lack of experience and knowledge if they have been given supervision or instruction concerning use of the appliance in a safe way and understand the hazards involved. Children should be supervised to ensure that they do not play with the appliance.
- This appliance is intended to be used for household and similar applications such as staff kitchen areas in shops, offices and other working environments; farm houses and by clients in hotels, motels and other residential type environments; bed and breakfast type environments; catering and similar non-retail applications.
- **WARNING!** To avoid a hazard due to instability of the appliance, it must be fixed in accordance with the instructions.

Contents

Unpack	4
Unpack Ice Machine	4
Site Preparation	5
Installation site requirements	5
Dispenser Preparation	6
Install Vision dispenser	6
Install bin signal	6
Install transport tube	7
Mount Ice Machine	8
Ice machine in cabinet	9
External Connections	11
Air-cooled ice machines only	11
Water-cooled ice machines only	11
Bin Stat Cable	11
Transport tube installation	12
General requirements	12
Procedure	12
RIDE model ice machine start up procedure	13
Before turning on power	13
After turning on power	13

1. Unpack

Carefully unpack and inspect the contents of your Follett ice machine.

1.1 Unpack Ice Machine

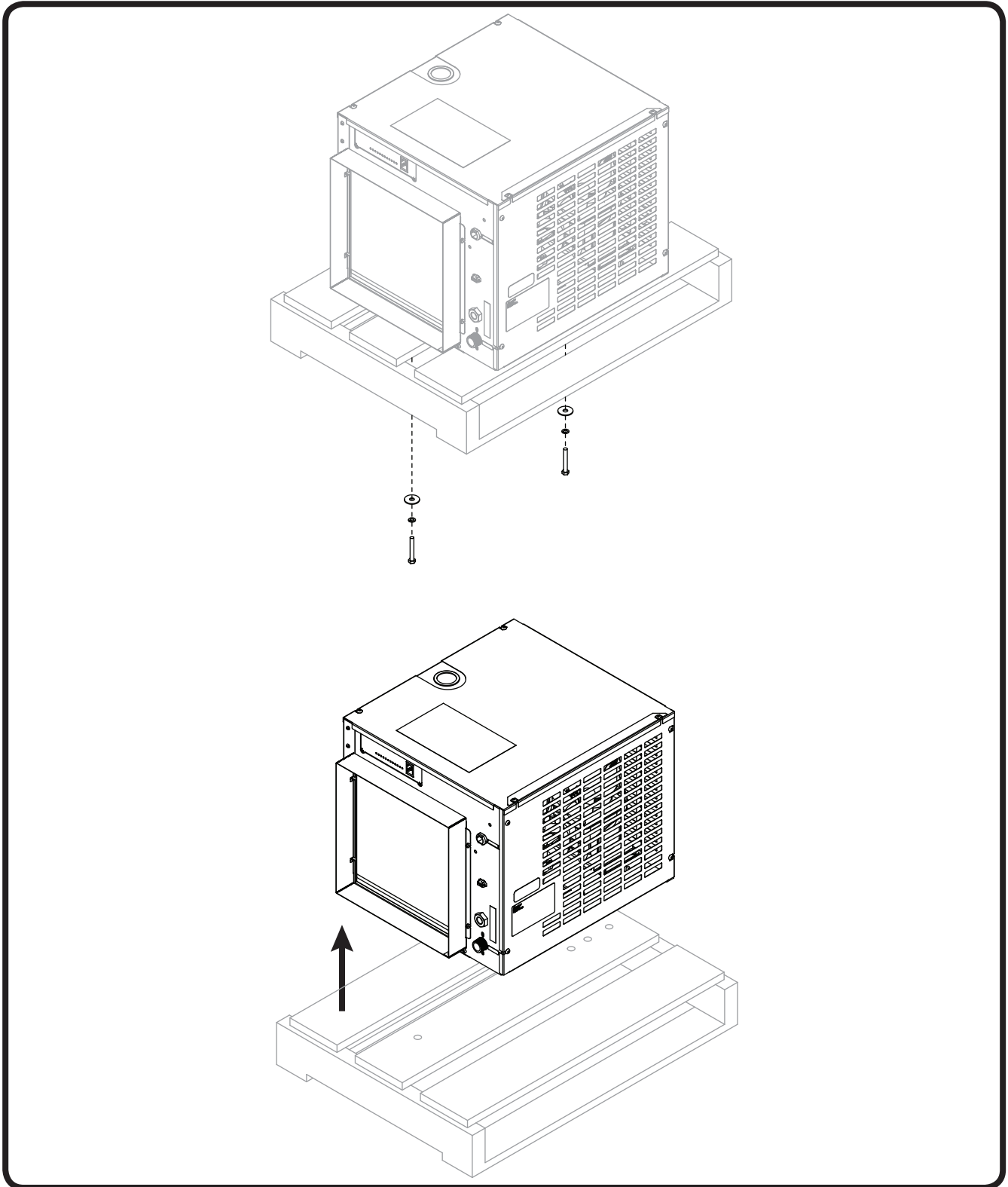

2. Site Preparation

Provide drainage, potable water supply and electrical power to within 6 feet (2m) of ice machine in accordance with local and national codes. Outdoor installation is not recommended and will void warranty.

2.1 Installation site requirements

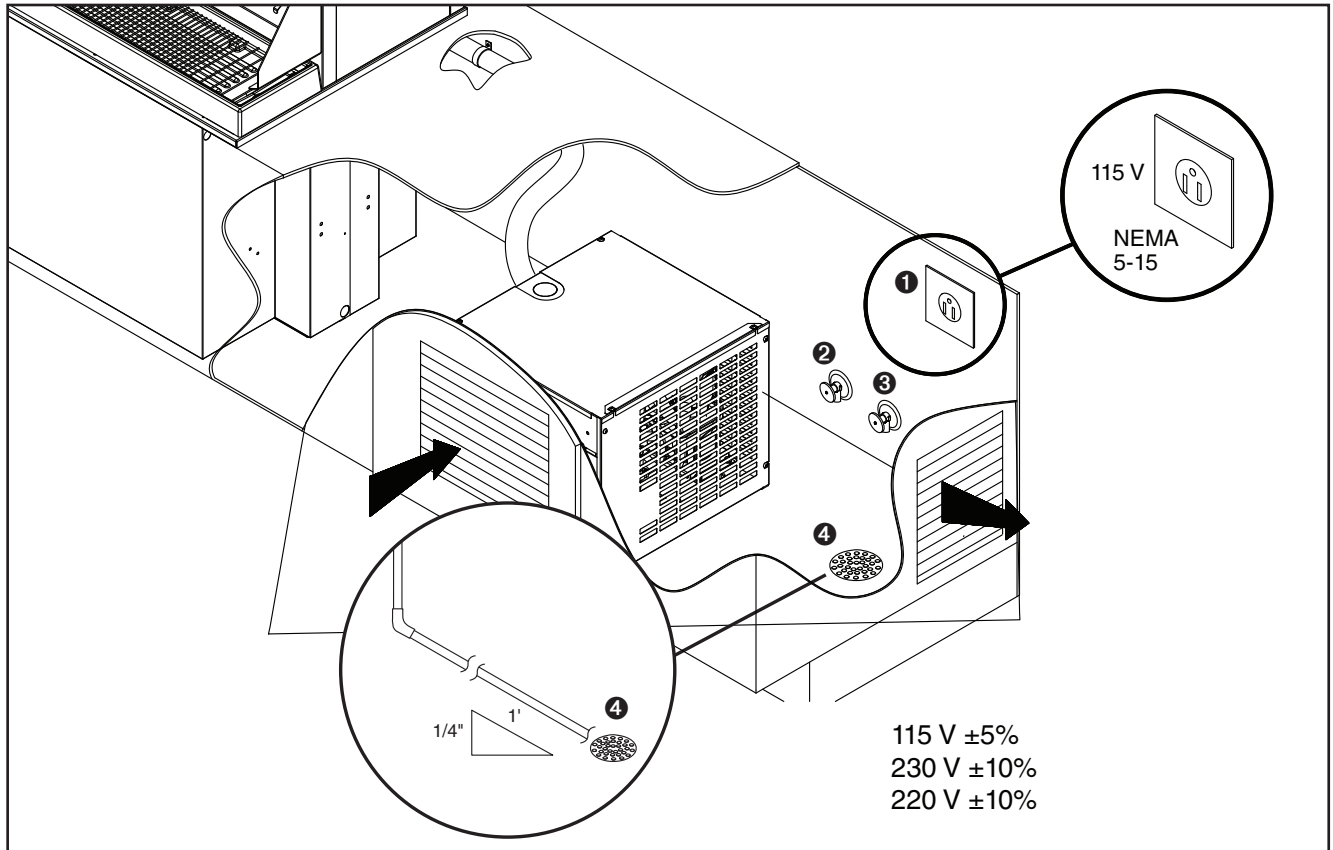

Electrical ①

⚠ WARNING!

- This appliance should be connected by a qualified person in accordance with application codes.
- If the supply cord is damaged, it must be replaced by the manufacturer, its service agent or similarly qualified persons in order to avoid a hazard.

MCD425(A/W)VS 115/60/1 (115 V ±10%) 15A breaker
(MCD requires a 15A dedicated circuit)

MCE425(A/W)VS (230/50/1 - 5.5A (full load)
(MCE425A/W requires a dedicated circuit, 1.50 mm² wire)

MCC425(A/W)VS (220/60/1 - 5.5A (full load)
(MCC425A/W requires a dedicated circuit)

Potable Water Supply ②

10 psi to 70 psi (69 kpa to 483 kpa)

45 F to 90 F (7 C to 32 C)

Condenser water supply for water-cooled systems ③

10 psi min.; 125 psi max. (69 kpa min.; 862 kpa max.)

20 F to 90F (-7 C to 32 C)

0.5 gallons (1.9 liters) per minute

Drain ④

The drain line from the ice machine must have at least 1/4 in. per foot (6,4 mm/0,3 m) pitch

3. Dispenser Preparation

3.1 Install Vision dispenser

Refer to Vision Installation, Operation and Service Manual packaged with dispenser for detailed instructions.

3.2 Install bin signal

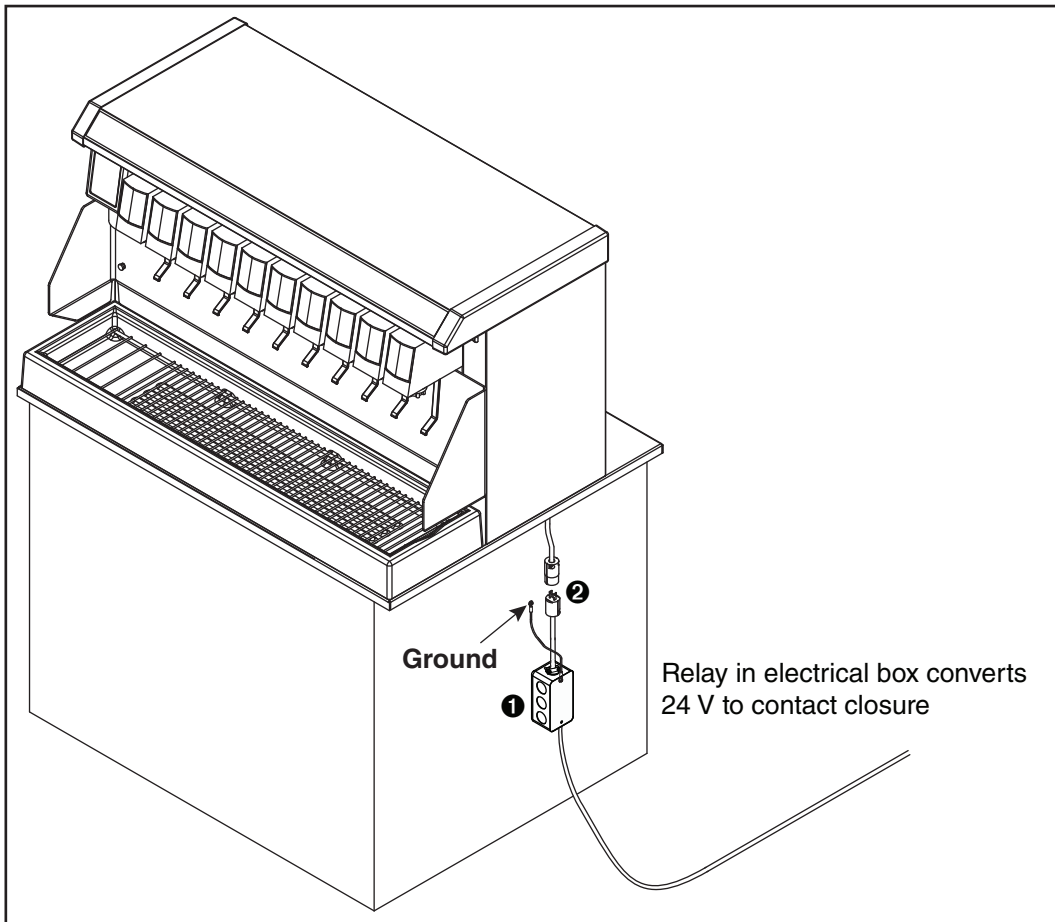

1. Mount the electrical box to the side of the Vision dispenser ① to establish a ground connection.

Note: If a 2 x 4 box is mounted to a non-grounded surface, connect ground wire at an appropriate ground.

2. Connect the bin signal plug on the electrical box to the bin signal cord on the bin ②

3. Final connection will be made after ice machine has been installed.

3.3 Install transport tube

Correct installation

- Length of run no more than 20 ft (6 m)
- Tube run continuously from ice machine to dispenser
- Insulation on entire run of tube
- No dips or tight bends
- Tube secured in place
- No splices

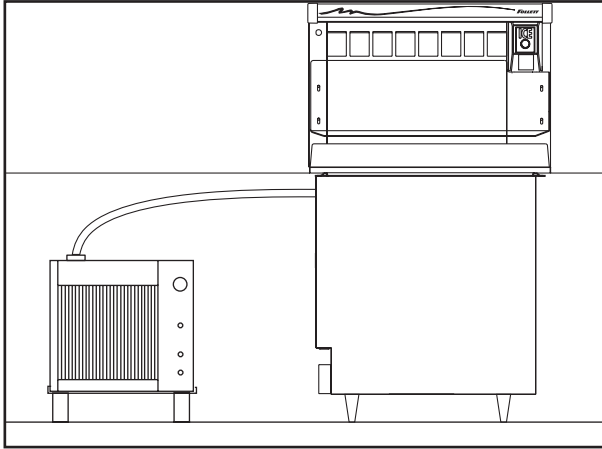

Incorrect installation

- Dips in tube where water can collect
- Splice or tight bend that restricts ice flow
- Uninsulated tube that results in wet ice and potential dispensing problems

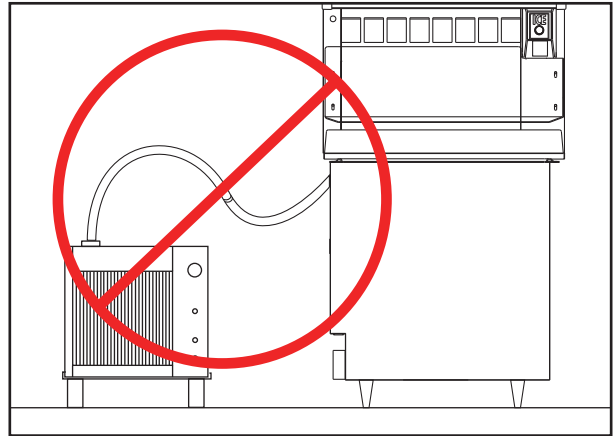

3.3.1 Additional ice transport tube connection specifications for Vision series ice and beverage dispensers

Check to make sure bin signal on ice machine control board is switched to 24 V connection.

1. Push one end of ice transport tube(s) through hole(s) provided in side of dispenser.
2. Route tube into ice tube bracket inside dispenser and engage bracket tabs in holes located in end of ice transport tube(s) (see drawings below).
3. Verify bin thermostat capillary tube is mounted correctly (see drawings below).

Ice tube retainer bracket

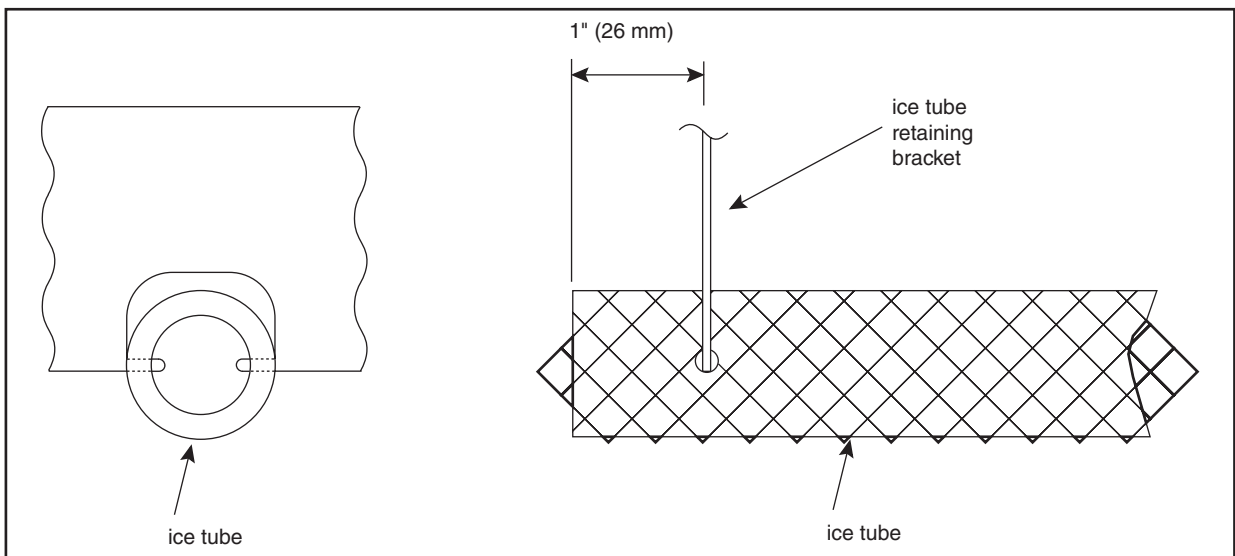

Bin thermostat capillary tube mounting

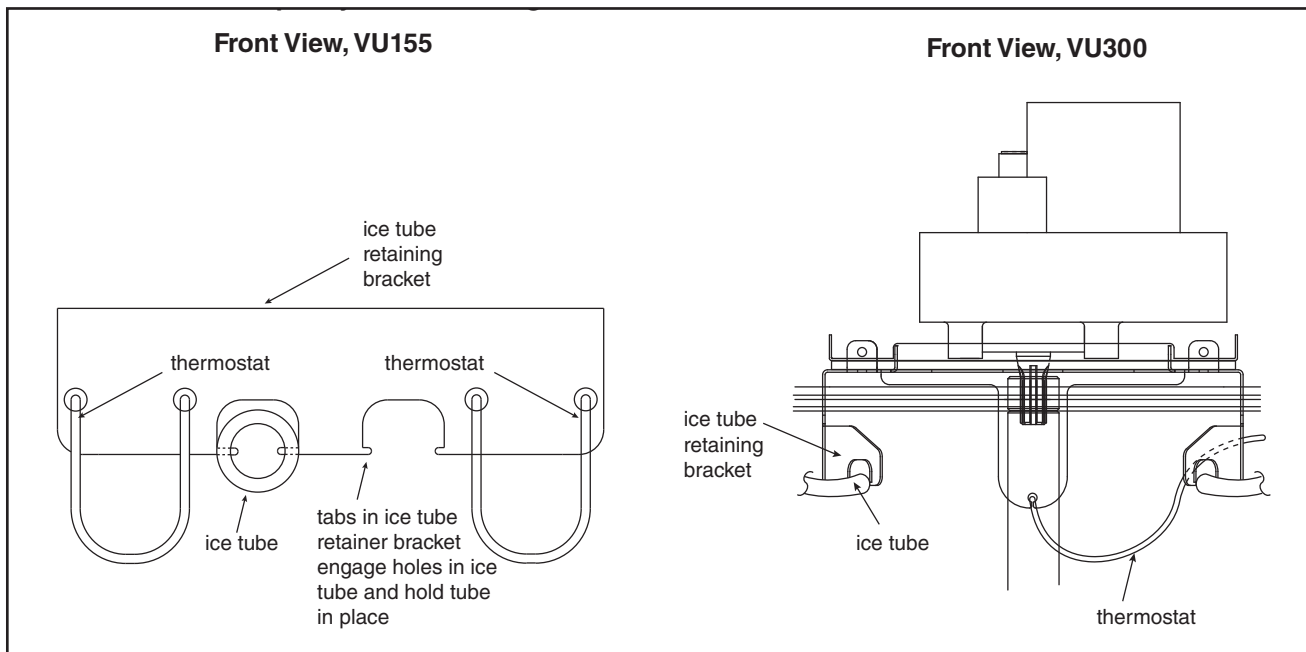

4. Mount Ice Machine

Mounting options: Cabinet, Wall, Stand

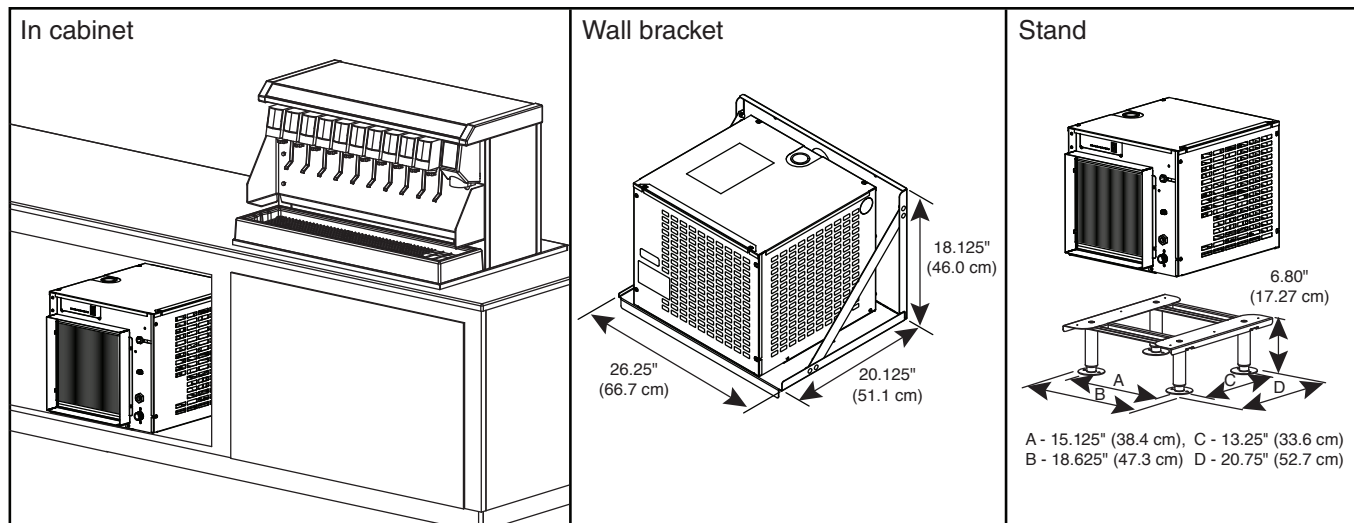

4.1 Ice machine in cabinet

Maestro ice machines can be installed undercounter/in-cabinet to fill bins or dispensers using RIDE technology. Care must be taken to ensure proper cabinet venting to avoid recirculation of hot air. Improper venting can cause ice machine outages.

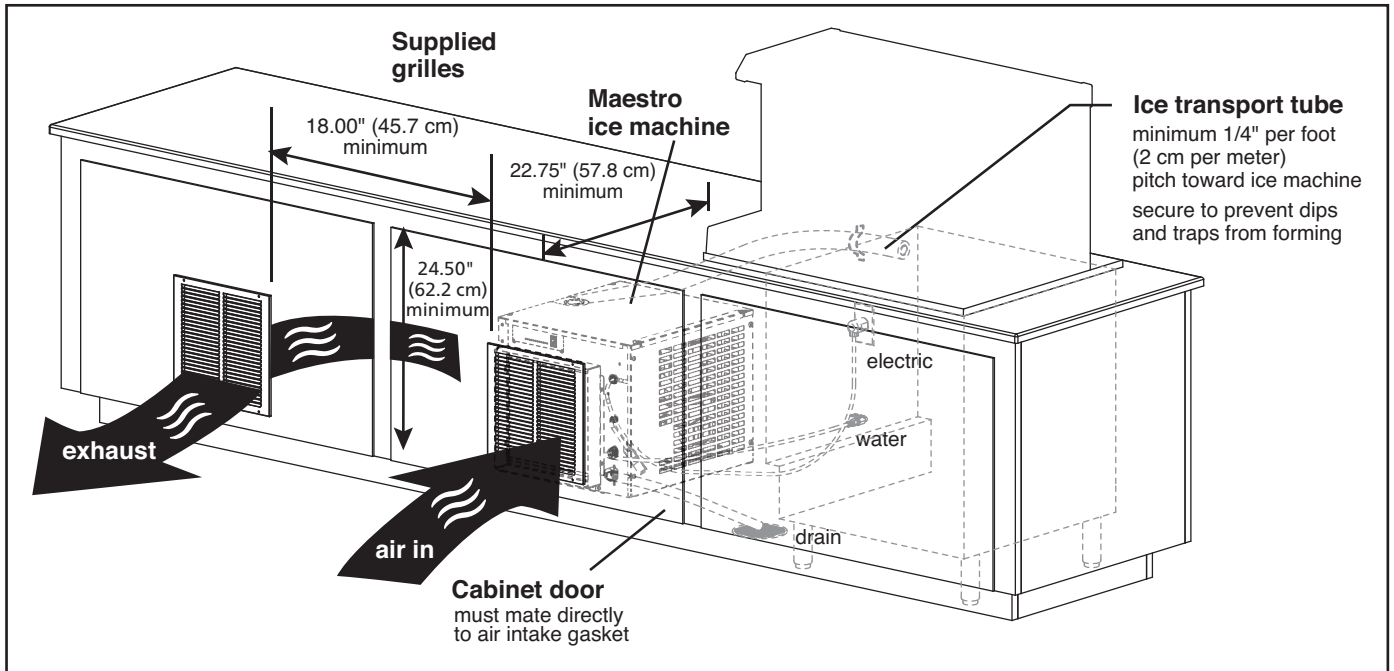

- The supplied exhaust grille must be located at least 18" (46 cm) from the supplied air intake grille (exhaust air must not recirculate with intake air).
 - Cabinet interior must be open to allow for unrestricted exhaust air flow.
 - Ice transport tube needs minimum 1/4" per foot (2 cm per meter) pitch toward ice machine and should be secured to prevent dips and traps from forming.
 - Cabinet door must mate directly to air intake gasket.
 - Cabinet interior must provide a minimum clear space of 22.75" deep (57.8 cm) by 29" high (74 cm).
- Note: 25.75" (65.4 cm) required for plug removal if receptacle located directly behind unit.**
- Cutout for supplied grilles must meet minimum size requirements shown above.
 - Utilities should be conveniently located as shown.

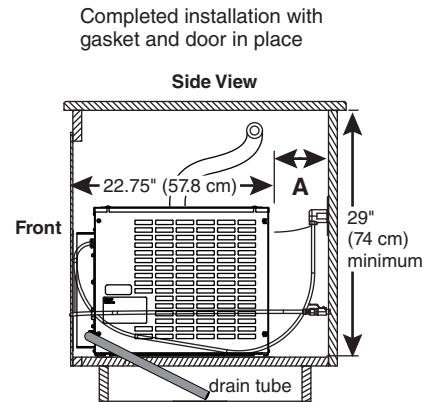
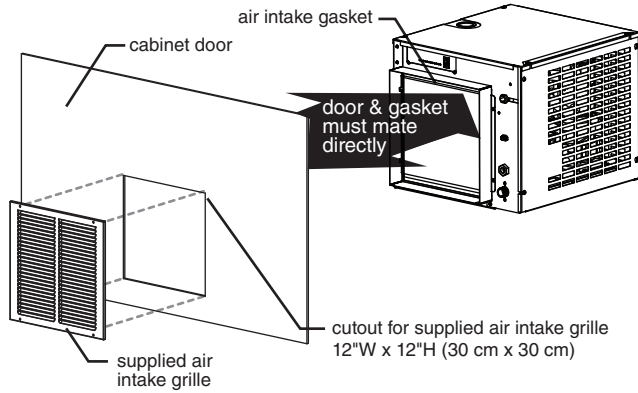

WARNING

- Keep ventilation openings in the appliance enclosure clear of obstruction. Failure to do so could result in damage to equipment.

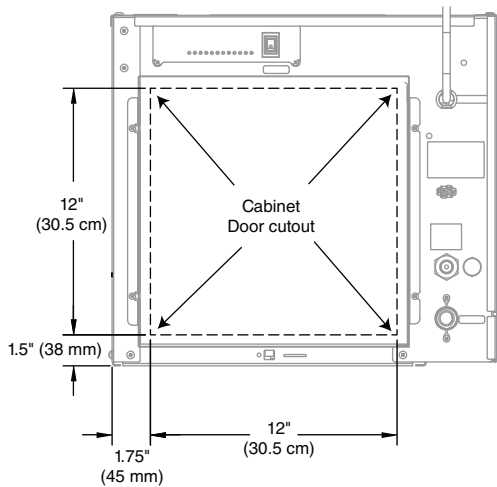
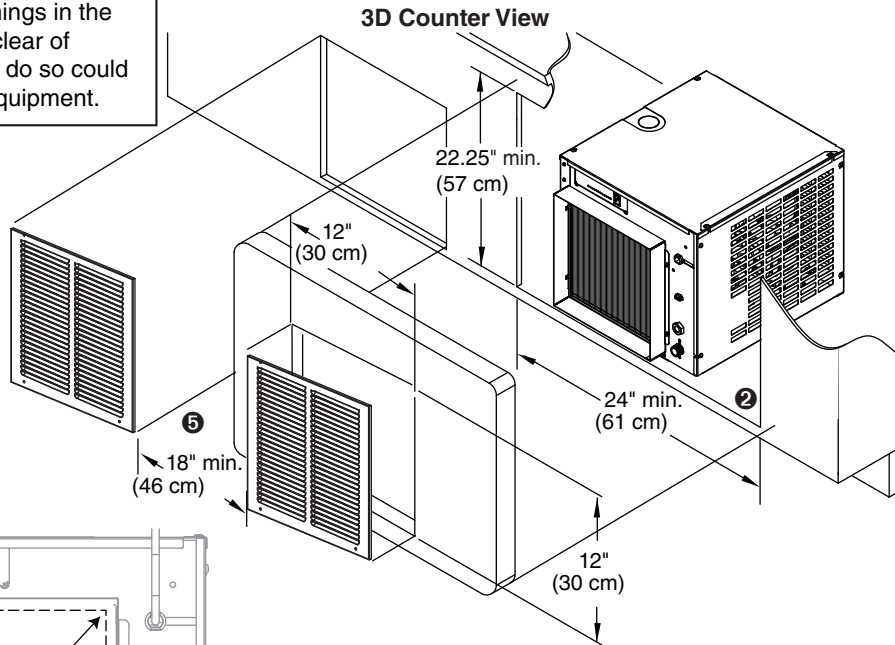

- Intake and Exhaust Grille Placement: air-cooled models only
 - Position the intake grille cut out in the access panel/door
- Note: Ice machine must be aligned with cut out and inside of access panel to provide a tight seal and prevent recirculation of hot exhaust air.**
- Left edge of cutout should be 1.75" (4.5 cm) from the left side of the ice machine ③

- Bottom edge of cutout should be 1" (2.5 cm) from the bottom of the ice machine ④
- Position supplied exhaust grille at least 18" (46 cm) away from intake grille ⑤. Where possible, install exhaust grille to the rear or side of the base cabinet.
- If not using supplied grille, air circulation requirements must be met: 160 sq. in (1032 sq cm) intake/exhaust air.

5. External Connections

5.1 Air-cooled ice machines only

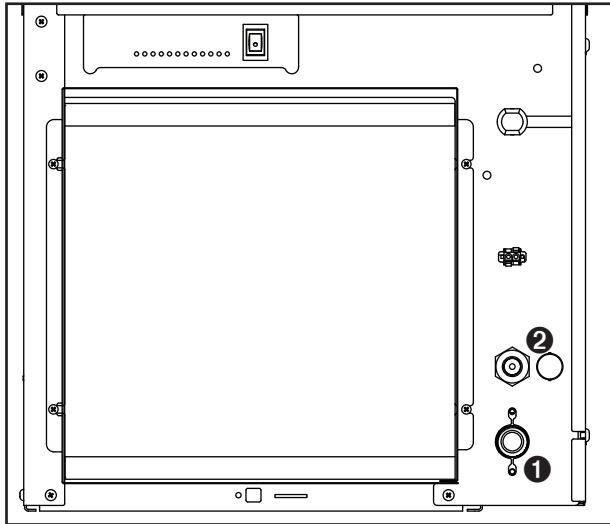

- Install drain line ① (3/4" MPT).
The rigid drain line from the ice machine must have at least 1/4" per foot (6,4 mm/0,3 m) pitch.
- Install ice machine potable water supply ② (3/8" FPT).

Note: Follett recommends a Follett water filter system be installed in the ice machine inlet water line (standard capacity #00130299, high capacity #00978957, carbonless high capacity #01050442).

5.2 Water-cooled ice machines only

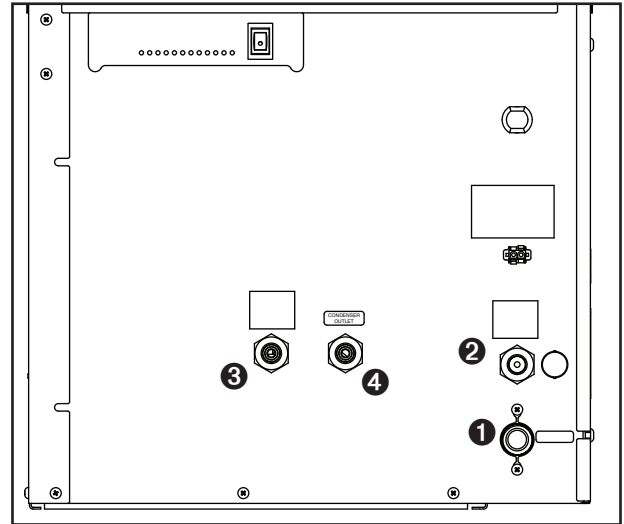

- Install drain line ① (3/4" MPT).
The rigid drain line from the ice machine must have at least 1/" per foot (6,4 mm/0,3 m) pitch.
- Install ice machine potable water supply ② (3/8" FPT).

Note: Follett recommends a Follett water filter system be installed in the ice machine inlet water line (standard capacity #00130299, high capacity #00978957, carbonless high capacity #01050442).

- Connect cooling water supply ③ and return ④ (3/8" FPT).

5.3 Bin Stat Cable

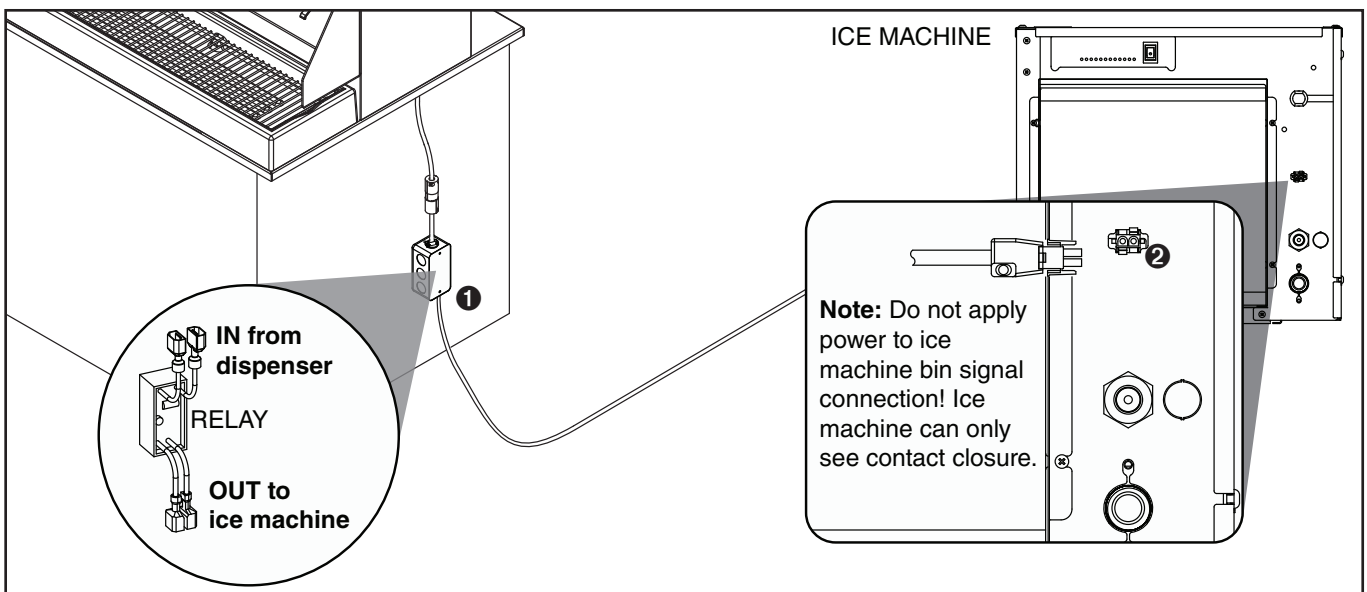

- Route 2-pin bin stat cable from Vision dispenser ① and connect at front of ice machine ②.

6. Transport tube installation

Incorrect ice transport tube installation can result in wet ice and dispensing problems. Follow guidelines below to ensure correct installation. Call factory for assistance if you are unable to meet these requirements.

6.1 General requirements

- Maximum length of tube run – 20 ft (6 m). Factory approval required for longer runs.
- Run tube without dips.
- One continuous length of tube; no splices.
- Minimum radius of bends in tube – 6" (15.3 cm) inside radius.
- Maximum number of bends – 6.
- Insulation on entire run of ice tube.

6.2 Procedure

1. Install supplied insulation on entire length of tube.
2. Remove ice machine top panel.
3. Select side, rear or top knockout in ice machine cabinet for tube entrance and install bushing.
4. Run insulated tube without dips between dispenser and ice machine and secure in place.
5. Slide end of transport tube and insulation through bushing and run to nozzle.
6. Cut tube to that length.
7. Pull insulation back and slip supplied hose clamp over end of transport tube.
8. Heat end of transport tube in cup of 160 F (71 C) hot water to soften ❶ and spread with pliers ❷ before making connection to ease assembly.
9. Push transport tube onto nozzle ❸.
10. Position clamp behind lip on nozzle and tighten clamp.

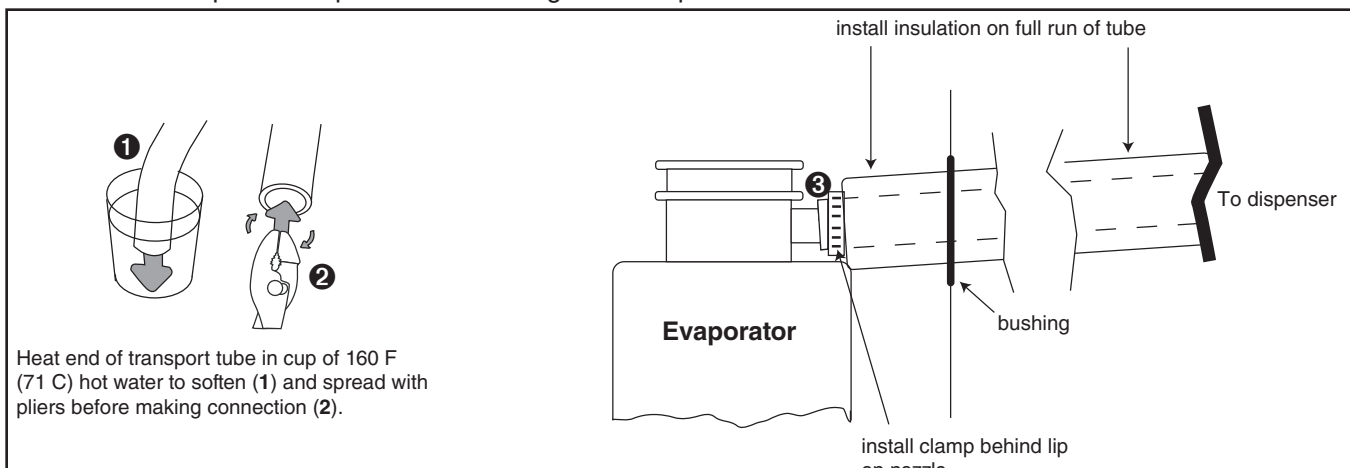

7. RIDE model ice machine start up procedure

The start-up procedure below is intended to ensure that ice machine is operating properly after installation has been made. Check each item listed and call factory immediately for assistance if you experience problems with unit.

NOTICE!

- Ice machine **MUST** be sanitized prior to operation!
- Consult Operation and Service Manual provided with ice machine for sanitizing instructions.

7.1 Before turning on power

1. Turn on water to ice machine.
2. Check that hose clamp securely holds ice transport tube on evaporator port.

7.2 After turning on power

1. Turn on power to ice machine and confirm that gearmotor, fan motor and compressor start immediately.
2. Check that ice begins to enter dispenser bin area within approximately 10 minutes.
3. Put ice against bin level thermostat in dispenser bin and check that compressor and gear motor shut down immediately after thermostat opens. Fan will continue to run for an additional 10 minutes.
4. Check that ice machine comes back on in approximately 20 minutes (bin signal must be present).

Maestro Plus and Harmony are trademarks of Follett LLC.

Follett, Chewblet and RIDE are registered trademarks of Follett LLC, registered in the US.

FOLLETT[®]
Innovative solutions, inspired by ice

801 Church Lane • Easton, PA 18040, USA
Toll free (877) 612-5086 • +1 (610) 252-7301
www.follettice.com



01062561R02
© Follett LLC 3/17