

Installation Guide

Please visit <https://www.follettice.com/technicaldocuments>
for the Operation and Service manual for your unit.

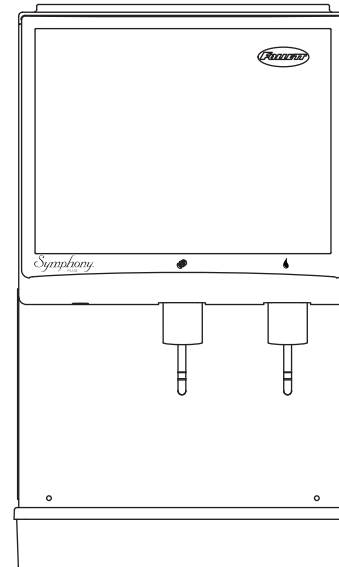
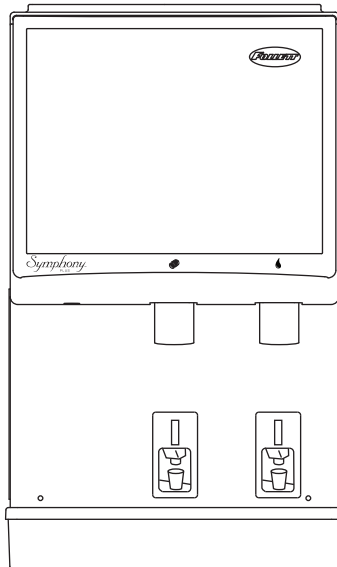

Welcome to Follett

Follett equipment enjoys a well-deserved reputation for excellent performance, long-term reliability and outstanding after-the-sale support. To ensure that this equipment delivers that same degree of service, review this guide carefully before you begin your installation.

Should you have need technical help, please call our Technical Service group at (877) 612-5086 or (610) 252-7301.

Please have your model number, serial number and complete and detailed explanation of the problem when contacting Technical Service.

Getting Started

After uncrating and removing all packing material. Inspect the equipment for concealed shipping damage. All freight is to be inspected upon delivery. If visible signs of damage exist, please refuse delivery or sign your delivery receipt "damaged." Follett Customer Service must be notified within 48 hours. Wherever possible, please include detailed photos of the damage with the original packaging so that we may start the freight claim process.

⚠ CAUTION!

- Do not tilt unit further than 30° off vertical during uncrating or installation.
- Dispenser bin area contains mechanical, moving parts. Keep hands and arms clear of this area at all times. If access to this area is required, power to unit must be disconnected first.
- This appliance is not suitable for installation in an area where a water jet could be used.
- This appliance must not be cleaned by a water jet.
- User maintenance should not be done by children.
- Follett recommends a Follett water filter system be installed in the ice machine inlet water line (standard capacity #00130229, high capacity #00978957, carbonless high capacity #01050442).
- Prior to operation clean the dispenser in accordance with instructions found in this manual.
- Do not block air intake or exhaust.
- This appliance should be permanently connected by a qualified person in accordance with application codes.
- A qualified person shall provide a readily accessible disconnect device incorporated into the fixed wiring.
- If the supply cord is damaged, it must be replaced by the manufacturer, its service agent or similarly qualified persons in order to avoid a hazard.
- This appliance can be used by children aged 8 years and above and persons with reduced physical, sensory, or mental capabilities, or lack of experience and knowledge if they have been given supervision or instruction concerning use of the appliance in a safe way and understand the hazards involved. Children should be supervised to ensure that they do not play with the appliance.
- This appliance is designed for commercial use.
- **WARNING!** To avoid a hazard due to instability of the appliance, it must be fixed in accordance with the instructions.
- Warranty does not cover exterior or outside installations.
- To reduce risk of shock, disconnect power before servicing.
- Connect to potable water supply only.
- Ice is slippery. Maintain counters and floors around dispenser in a clean and ice-free condition.
- Ice is food. Follow recommended cleaning instructions to maintain cleanliness of delivered ice.

Specifications

Countertop

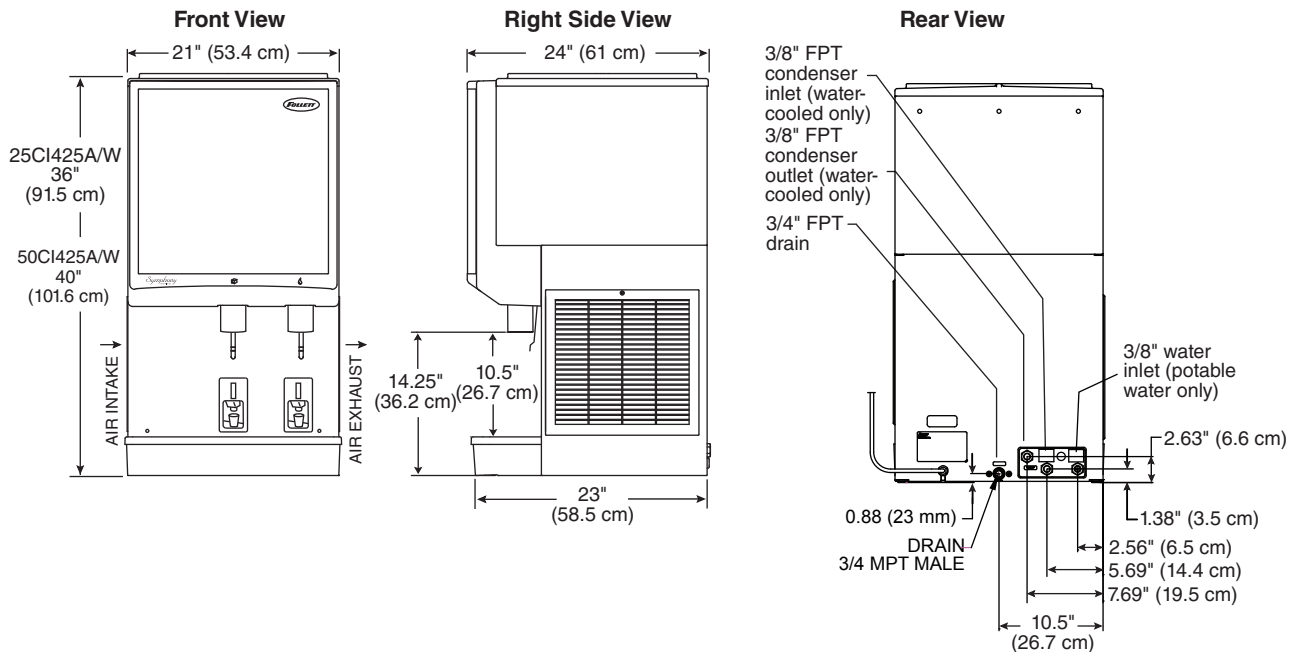

Ambient

Air temp*	100 F/38 C Max.	50 F/10 C Min. (Best performance below 80 F (27 C))
Water temp†	90 F/32 C Max.	45 F/7 C Min. (Best performance below 70 F (21 C))
Water pressure (psi/bar)	70/5 Max.	10/0.7 Min.

* Ambient air temperature is measured at the air-cooled condenser coil inlet.

† Ambient water temperature is measured in the ice machine float reservoir.

Electrical

- 220 V, 60 Hz, 1 phase, 5.5A or 230 V, 50 Hz, 1 phase, 5.5A
- Connect to a dedicated circuit.
- Furnished with 7 ft (2 m) power cord.

Plumbing

	Connections	Rough-ins
Dispenser drain	3/4" MPT	Air-cooled 3/4" FPT
Water inlet	3/8" FPT	3/8" FPT

Note: Water shut-off recommended within 10 ft. (3m) of dispenser. Drain to be hard-piped and insulated. Maintain at least 1/4" per foot (20 mm per 1 m) run of slope.

Ventilation clearances

	Air-cooled
Required for ventilation	3" (77 mm) each side
Suggested for service	12" (30.5 cm) top, 6" (15.3 cm) left side

Note: Do not block left side air intake or right side air exhaust.

Dry weight

- C/E25/50CI425 (countertop): 215 lbs. (98 kg)

Refrigeration system

Important: All service on refrigeration system must be performed in accordance with all federal, state and local laws that pertain to the use of refrigerants. It is the responsibility of the technician to ensure that these requirements are met.

Model	Charge	Refrigerant type
C25/50CI425A	15 oz	R404A
E25/50CI425A	13 oz	R449A

Compressor data

Air-cooled										
Ambient air temperature	60 F/15.6 C		70 F/21.1 C		80 F/26.7 C		90 F/32.2 C		100 F/37.8 C	
	220 V	230 V	220 V	230 V	220 V	230 V	220 V	230 V	220 V	230 V
Amperage	2.65	2.25	2.77	2.36	2.89	2.46	3.01	2.57	3.13	2.68
High-side pressure (psi)	219	199	256	233	293	266	330	306	367	346
Low-side pressure (psi)	28	29	30	31	33	33	35	36	38	38

Locked rotor amps	220 V: 19.6A	230 V: 18.2A
Condenser water usage:	@70 F/70F: 0.26 gal/min	@90 F/70F: 0.56 gal/min

Gearmotor data	220 V/60 Hz	230 V/50 Hz
Gearmotor current	1.0A (nominal)	1.3A (nominal)
Locked rotor amps	6.8A	6.8A

Installation

Before you begin

- All dispensers must be installed level in both directions to ensure proper operation.
- Provide proper ventilation clearances.
- Countertop units provide the option of taking utilities out bottom or back of dispenser (on countertop units with legs, utilities exit from back).
- Wall mount model utilities exit through back of dispenser only.
- Directions for each installation follow.

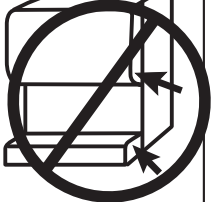
 WARNING!	
	<ul style="list-style-type: none">▪ DO NOT LIFT UNIT AT THESE POINTS. Panels will not support weight of unit▪ Failure to follow warning may result in equipment damage or personal injury

Installing countertop dispensers with rear exiting utilities (no legs)

1. Position dispenser in desired location.
2. Mark dispenser outline on counter and remove dispenser.
3. Drill four 7/16" holes in counter to anchor dispenser to counter (**Fig. 1**).
4. Apply a thick bead approximately 1/4" (7 mm) diameter of NSF listed silicone sealant (Dow Corning® RTV-732 or equivalent) 1/4" (7 mm) inside marked outline of dispenser.
5. Reposition dispenser on counter and secure to counter with four 3/8"-16NC bolts.
6. Smooth excess sealant around outside of dispenser.
7. Make utility connections (**Fig. 2**).
8. Turn on water supply and check for leaks.
9. Clean dispenser and ice machine before putting into service.
10. Turn power on and allow ice machine to produce ice.

Fig. 1 Countertop anchoring locations

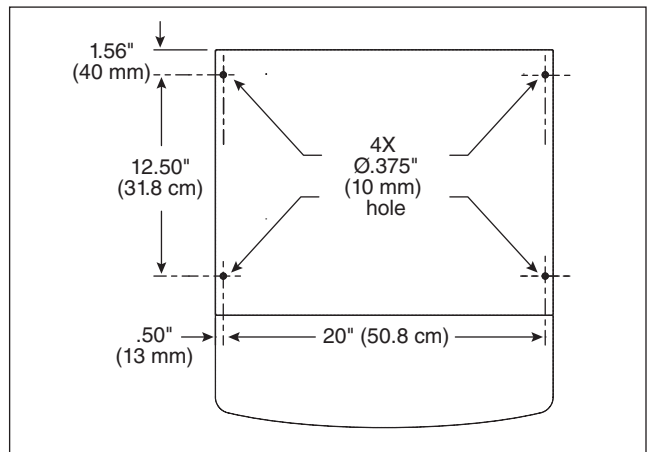
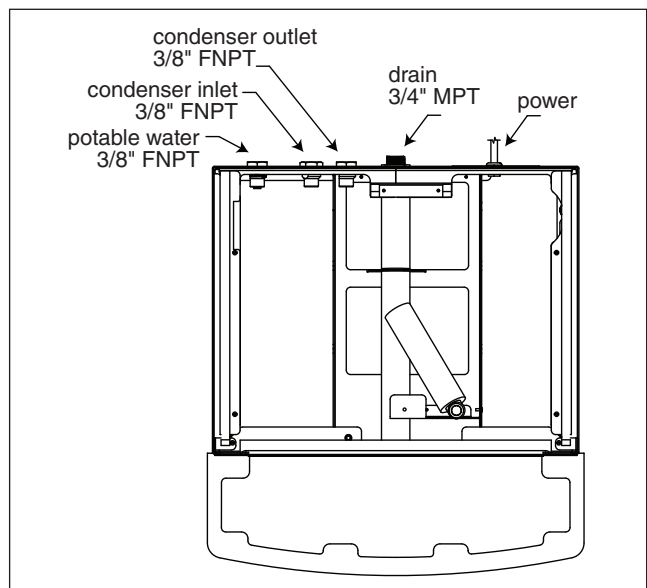

Fig. 2 Utility connections as viewed from top for countertop back access



Installing countertop dispensers with bottom exiting utilities



WARNING!

- A sturdy work surface capable of supporting the entire dispenser must be used.
- The work surface must be large enough to accommodate height of dispenser.
- Failure to provide proper support may result in personal injury.

1. Position dispenser with dispense chutes facing upward on sturdy work surface (**Fig. 3**).
2. Move drain fitting from back of dispenser and mount (**Fig. 4.1**).
3. Cut drain tube to length and attach to barbed connection (**Fig. 4.2**).
4. Move inlet water fitting from back of dispenser and mount (**Fig. 4.3**).
5. Cut water tubing to length and re-insert into water fitting.
6. Remove the drain plug from the internal drain line connection point and relocate to back of dispenser and reconnect.

7. Raise the dispenser upright and position in desired location.
8. Mark dispenser outline on counter and remove dispenser.
9. Cut countertop utility opening and drill four 7/16" holes to anchor dispenser to counter (**Fig. 5**).
10. Apply a thick bead approximately 1/4" (7 mm) diameter of NSF-listed silicone sealant (Dow Corning* RTV-732 or equivalent) 1/4" (7 mm) inside marked outline of dispenser.
11. Reposition dispenser on counter and secure to counter with four 3/8"-16NC bolts.
12. Smooth excess sealant around outside of dispenser and make utility connections through countertop cutout.
13. Turn on water supply and check for leaks.
14. Clean dispenser and ice machine.
15. Turn power on and allow ice machine to produce ice.

Fig. 3

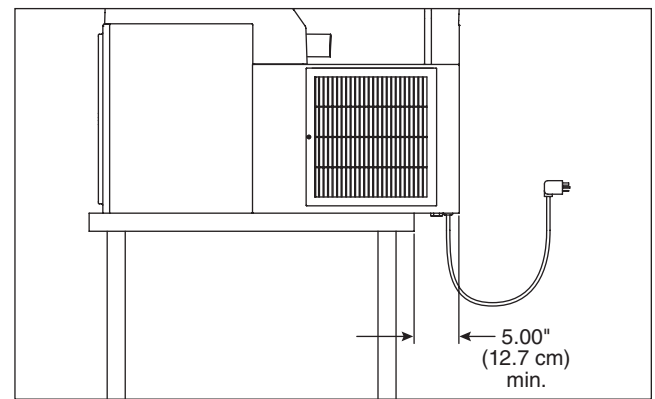

Fig. 4

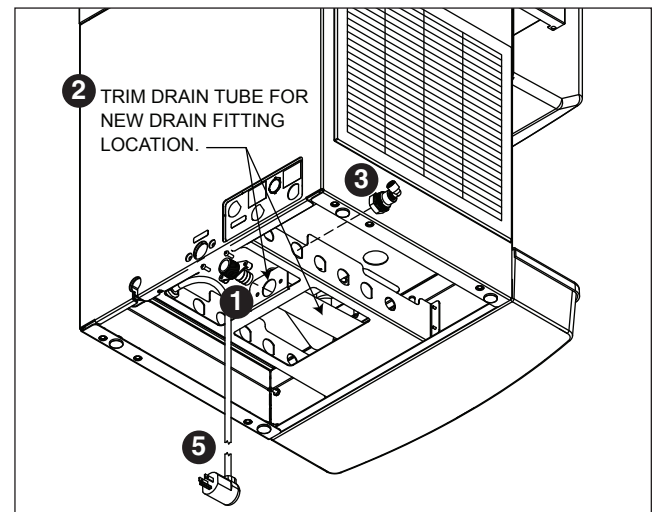
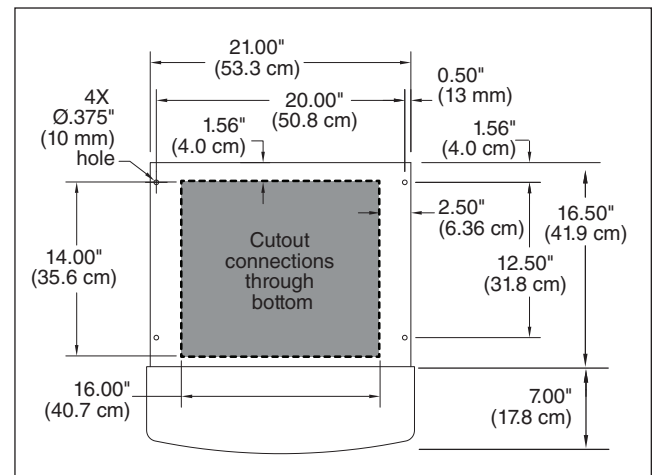

Fig. 5



Cleaning

Follett ice machines and dispensers, and their associated cleaning and sanitizing procedures, are designed for use with potable water sources. The presence, or suspected presence, of infectious agents may call for additional measures, including the replacement of components and more comprehensive disinfection measures. Follett recommends that these cleaning and sanitizing procedures be reviewed with the appropriate infectious agent subject matter experts to assure complete remediation.

Periodic cleaning of Follett's ice and water dispenser and ice machine system is required to ensure peak performance and delivery of clean, sanitary ice. The recommended cleaning procedures that follow should be performed at least as frequently as recommended and more often if environmental conditions dictate.

Follett recommends sanitizing the pressurized water lines prior to cleaning the ice machine/dispenser. Follett offers two kits: order P/N [01089572](#) when a Follett filter system with a pre-filter bowl is present, or P/N [01089580](#) when a Follett filter system is not present. Follow the instructions provided with the respective kits to sanitize the pressurized water lines immediately before cleaning the ice machine/dispenser.

Cleaning of the condenser can usually be performed by facility personnel. Cleaning of the ice machine system should be performed by your facility's trained maintenance staff or a Follett authorized service agent. Regardless of who performs the cleaning, it is the operator's responsibility to see that this cleaning is performed according to the schedule below. Service problems resulting from lack of preventive maintenance will not be covered under the Follett warranty.

Recommended cleaning intervals*

Symphony Plus	Frequency
Drain Line	weekly
Drain Pan/Drip Pan	weekly
Exterior, Water Station Tube	as needed
Condenser	monthly (air-cooled only)
Dispenser and Components	semi-annually
Ice Machine	semi-annually
Transport Tube	semi-annually
Ice Storage Area/Bin	semi-annually
Pressurized Water Sanitizing	semi-annually

* Ice machine and dispenser must be cleaned prior to start-up.

Weekly



- Do not use solvents, abrasive cleaners, metal scrapers or sharp objects to clean any part of the dispenser.

Dispenser drain pan and drain line

- Pour 1 gal. (3.8 L) of hot tap water into drain pan to flush drains.

Splash panel front, SensorSAFE™ infrared dispensing

- Deactivate dispensing by pressing and releasing clean switch located on left side of unit under top front cover.
- Clean lens and splash panel front using a soft cloth and mild, non-abrasive, non-chlorine based cleaner.
- Reactivate dispensing by pressing and releasing clean switch again.

Monthly



- Do not use solvents, abrasive cleaners, metal scrapers or sharp objects to clean any part of the dispenser.

Condenser (air-cooled ice machine only)

- Use a vacuum cleaner or stiff brush to carefully clean condenser coils of lint and debris to ensure optimal performance.

Semi-Annually (more often if conditions dictate)

- A cleaning procedure should always include both the ice machine and dispenser.
- Icemaking system can be cleaned in place.



CAUTION!

- Wear rubber gloves and safety goggles (or face shield) when handling SafeCLEAN Plus™ and IMS-III solutions.
- Use only Follett approved cleaners.
- Do not use solvents, abrasive cleaners, metal scrapers or sharp objects to clean any part of the dispenser.

Cleaning Tool Checklist

- (1 or 2) 1.5 gallon (or larger) plastic bucket
- (2) clean cloths
- Sanitary gloves
- Safety glasses
- (2) SaniSponge™ (P/N 00131524 - single sponge)
- SafeCLEAN Plus ice machine cleaner

SafeCLEAN Plus Solution: Follow the directions on the SafeCLEAN Plus packaging to mix 1 gal. (3.8 L) of Follett SafeCLEAN Plus solution. Use 100 F (38 C) water.

Ice Machine and Dispenser

Cleaning Procedure

Note: Check drains and drain cup to ensure they are open and flowing freely.

1. If ice machine was running recently, ensure that the evaporator is completely free of ice before proceeding. If there is ice in the evaporator, complete steps 2-7 using only hot water to remove the ice, then begin Cleaning Procedure again.
2. Remove front cover and turn **OFF** bin signal switch.
3. Dispense all ice from storage hopper and discard.
4. Remove splash panel.
5. Press **CLEAN** switch. The **MAINTENANCE** light will turn on and the machine will drain. Wait for the **LOW WATER** light to turn on.
6. Remove lid from cleaning cup and fill (about 1 quart) until SafeCLEAN Plus solution completely fills the reservoir. Place lid back on cup. Save remainder of SafeCLEAN Plus solution.
7. **CLEANER FULL** light will turn on and machine will start cleaning cycle, then rinse three times; this process takes approximately 15 minutes.
8. While ice machine is cleaning, clean dispenser as follows:
 - a. Turn **OFF** dispenser power.
 - b. Remove hopper lid.
 - c. Remove knurled nuts from front of storage hopper.
 - d. Remove stud assembly, baffle, wheel, and any remaining ice.
 - e. Remove dispense chutes from splash panel.
 - f. Submerge drain grille in SafeCLEAN Plus solution and allow to soak to remove any scale buildup.
 - g. Wipe inside of hopper lid, stud assembly, baffle, wheel, inside of storage area, dispense chutes, drain grille and drain pan with damp cloth wrung out in SafeCLEAN Plus solution. Thoroughly rinse all parts with damp cloth wrung out with clean water.

Note: To avoid possible damage to motor assembly, only use a damp cloth to clean storage hopper. Do not allow water to run through motor shaft hole in bottom of hopper.

9. When machine is finished cleaning, the **MAINTENANCE** light will turn off.
10. Reinstall dispense chutes, wheel, baffle, stud assembly and knurled nuts.
11. Remove top bearing insulation. Loosen Phillips-head screw on nozzle connected to evaporator. Remove nozzle from evaporator side only, leave other side of nozzle connected to transport tube.
12. Soak one SaniSponge in remaining SafeCLEAN Plus solution.
13. Insert the sponge soaked in cleaning solution into nozzle, then insert a dry sponge into the nozzle.
14. Replace nozzle onto evaporator and tighten screw. Ensure drain is connected to reservoir and vent tubes are connected to evaporator drain pan. Replace top bearing insulation.
15. Turn **ON** bin signal switch. Wait for ice to push sponges through transport tube.
16. Collect sponges from ice storage bin.
17. Replace hopper lid, machine top, turn **ON** dispenser power and install front cover.
18. After 10 minutes, dispense all ice and discard.

User Interface and Exterior Cabinet

- Clean stainless steel panels with stainless steel cleaner.

Dispenser troubleshooting



- Disconnect power to unit before putting hands or arms in storage area or attempting any repair or service to equipment.

Before calling for service

1. Check that no ice is in the dispenser bin area.
2. Check that congealed ice is not causing a jam.
3. Check that all switches and circuit breakers are on.
4. Check that all drains are clear.
5. Check that water is supplied.

Lever model troubleshooting guide

Problem	Indicators	Corrective Action
Does not dispense ice.	<ol style="list-style-type: none"> 1. Power switch off or faulty. 2. Faulty dispense switch. 3. Wheel motor malfunction. 	<ol style="list-style-type: none"> 1. Check switch – turn on or replace if faulty. 2. Replace switch. 3. Check motor and replace
Dispense wheel rotates continuously.	Dispense switch contacts are burned out.	Replace dispense switch.
Ice machine runs continuously.	Faulty or incorrectly positioned bin stat.	Check for proper positioning. If stat does not open when ice is placed on capillary tube, replace stat.
Does not dispense water.	<ol style="list-style-type: none"> 1. Faulty water solenoid valve. 2. Faulty dispense switch. 3. Power switch off or faulty. 	<ol style="list-style-type: none"> 1. Replace water solenoid valve. 2. Replace dispense switch. 3. Check switch - turn on or replace if faulty.

SensorSAFE model troubleshooting guide

Problem	Action	SensorSAFE Board LED Status			Corrective Action
		PWR	CLN	ICE/WTR	
Does not dispense ice and/or water.	Check LEDs on the SensorSAFE control board.	OFF	OFF	OFF	Check circuit breakers and power switch. Restore power or replace defective switch.
		ON	ON	OFF	Press clean switch on lower left side of electrical enclosure to return board to normal operation.
	Place cup under drop zone (in front of lens)	ON	OFF	OFF	Troubleshoot appropriate lens/sensor and replace if required.
		ON	OFF	ON	Verify power on appropriate output terminal (WTR or WM) on control board and replace board if required. If board tests okay, troubleshoot appropriate dispenser component.
Dispenses ice and/or water continuously.	Check LEDs on control board.	ON	OFF	ON	Troubleshoot appropriate lens/sensor and replace if required.
		ON	OFF	OFF	If there is power on any output terminal (WTR or WM) on control board, replace board.

Warranty Registration and Equipment Evaluation

Thank you for purchasing Follett® equipment. Our goal is to deliver high value products and services that earn your complete satisfaction by delivering high-value products and services backed by outstanding customer and technical support.

Please review the installation instructions thoroughly. It is important that the installation be performed to factory specifications so your equipment operates at its maximum efficiency.

Follett LLC will not be liable for any consequential damages, expenses, connecting or disconnecting charges, or any losses resulting from a defect of the machine. For full warranty details, visit our website www.follettice.com/productwarranties.

Registering your equipments helps Follett track your equipment's service history should you need to contact us for technical support, and your feedback helps us improve our products and services. Please visit www.follettice.com/support to complete the Warranty Registration form.

Should you have any questions, please contact Follett's technical support group at (877) 612-5086 or (610) 252-7301 and we will be happy to assist you.

Calgon is a licensed trademark distributed by Nu-Calgon, in the United States.

Dow Corning is a registered trademark of Dow Corning Corporation in the United States and other countries.

SafeCLEAN, SaniSponge, SensorSAFE, and Symphony Plus are trademarks of Follett LLC.

Follett is a registered trademarks of Follett LLC, registered in US.



801 Church Lane • Easton, PA 18040, USA
Toll free (877) 612-5086 • +1 (610) 252-7301
www.follettice.com

Follett Europe Polska Sp. z o.o.
Mokry Dwór 26 c • 83-021 Wiślina, Poland
+48 (58) 785-6140 • Fax +48 (58) 785-6159
www.folletteurope.com



01083872R03
© Follett LLC 11/19