



VRP® Variable Refrigerant Packaged Heat Pump

Innovative | Intelligent | Inverter

VRP12K/R
VRP24K/R

For Commercial and Residential
Applications

One or more of the following
patents may apply:

10408504
10436457
10488083
10731899

Additional patents pending

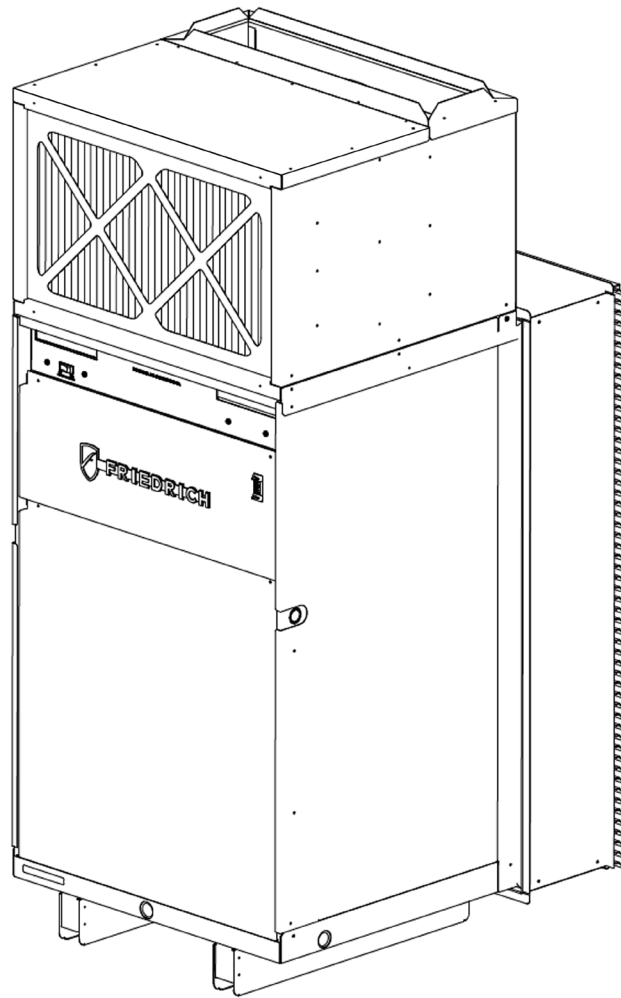

Table of Contents

Warnings	3
----------	---

General

Specifications	4
Dimensions	5
Electrical Data	6
Air Flow Data	7

Installation

Minimum Clearances	8
Installation Orientations	9
Rough Opening Dimensions	10
Preliminary Plumbing	12
Wall Plenum Installation	13
Louver Installation	17
Unit Installation	19
Drain Installation	22
Ductwork Installation	23
Wall Controller Installation	24
Electrical Connection	26
Return Air Door Installation	27
FreshAire™ System Set-Up and Operation	28

Reference

Electrical Wiring Diagrams	29
Basepan Heat	34
Final Installation Checklist	35
Service and Warranty	36
Accessories	37
Diagnostic Error Codes	39
VRP Limited Warranty	40

Congratulations!

The Friedrich VRP has been carefully engineered and manufactured to provide many years of dependable, efficient operation while maintaining a comfortable temperature and humidity level. Many extra features have been built into the unit to ensure quiet operation, optimal circulation of cool, dry air, and the most economic operation.

Please carefully read and follow the installation instructions and safety warnings detailed in this manual. All applicable national and local mechanical and electrical codes should be followed and take precedence over any Friedrich requirements or recommendations regarding installation applications detailed in this manual.

⚠ WARNING

Please read this manual thoroughly prior to equipment installation or operation. It is the installer's responsibility to properly apply and install the equipment. Installation must be in conformance with the NFPA 70-2008 National Electric Code or current edition, International Mechanical code 2009 or current edition and any other applicable local or national codes.

WARNING

Refrigeration system under high pressure. Do not puncture, heat, expose to flame or incinerate. Only certified refrigeration technicians should service this equipment. R410A systems operate at higher pressures than R22 equipment. Appropriate safe service and handling practices must be used. Only use gauge sets designed for use with R410A. Do not use R22 gauge sets. Failure to do so can result in property damage, personal injury, or death.

⚠ WARNING

Electrical shock hazard.

Turn OFF electric power before service or installation. Unit must be properly grounded. Unit must have correct fuse or circuit breaker protection. Unit's supply circuit must have the correct wire conductor size. All electrical connections and wiring must be installed by a qualified electrician and conform to the National Electrical Code and all local codes which have jurisdiction. Failure to do so can result in property damage, personal injury and/or death.



Your safety and the safety of others are very important.

We have provided many important safety messages in this manual and on your appliance. Always read and obey all safety messages.



This is the safety Alert symbol. This symbol alerts you to potential hazards that can kill or hurt you and others. All safety messages will follow the safety alert symbol with the word "WARNING" or "CAUTION". These words mean:

WARNING

Indicates a hazard which, if not avoided, can result in severe personal injury or death and damage to product or other property.

CAUTION

Indicates a hazard which, if not avoided, can result in personal injury and damage to product or other property. All safety messages will tell you how to reduce the chance of injury, and tell you what will happen if the instructions are not followed.

NOTICE

Indications property damage can occur if instructions are not followed.

THINK SAFETY FIRST	⚠ WARNING	⚠ AVERTISSEMENT	⚠ ADVERTENCIA
	Do not remove, disable or bypass this unit's safety devices. Doing so may cause, fire, injuries or death.	Ne pas supprimer, désactiver ou contourner cette l'unité des dispositifs de sécurité. faire vous risqueriez de provoquer, le feu, les blessures ou la mort.	No eliminar, desactivar o pasar por alto los dispositivos de seguridad de la unidad. Si lo hace podría producirse fuego, lesiones o muerte.

General Specifications

Nomenclature

V	R	P	2	4	K	2	5	S	S	A	S	A	- A00
Series		VRP Heat Pump										Marketing Revision	Engineering Revision
Nominal Capacity (Btu /Hr.)		12 = 5400- 16000 Operating Range		24 =14500 - 28000 Operating Range								S= Standard L= Basepan Heat	
Voltage		K = 230/208 V		R = 265 V								Plenum and Louver Configuration A= Compact (VRP12 Only) B= Standard	
Heater Watts		25 = 2.5 kW		VRP12 Only		34 = 3.4 kW		50 = 5.0 kW		75 = 7.5 kW		VRP24 Only	
		10 = 10.0 kW										S= Standard R= Reheat	
												Outdoor Air/ Ventilation S= Standard No FreshAir™ F= Single OA Fan 35 CFM D= Dual OA Fans 70 CFM	

Model	VRP12K / VRP12R		VRP24K / VRP24R	
Cooling Performance Data (Cooling Standards: 95°F DB/75°F WB outdoor, 80°F DB/67°F WB indoor)				
Voltage	230/208	265	230/208	265
Cooling Btu (Rated)	11500		23400	
Cooling Btu (Min. - Max)	5400 - 16000		14500 - 28000	
Outdoor Operating Range (°F)	55 - 115		55 - 115	
Power (W)	1106		2925	
SEER2	15.1	14.7	13.7	
EER2	10.4		8.0	
Sensible Heat Ratio	0.74		0.74	
Cooling Amps	5.3	4.6	13.9	11.9
Heat Pump Performance Data				
Voltage	230/208	265	230/208	265
Heating Btu (Rated @ 47° F)	11200		21000	
Heating Btu (@ 17° F)	6200		13000	
Heating Btu (Min. - Max.)	4000 - 14000		12000 - 26000	
Heat Pump Outdoor Operating Range (°F)	0 - 70		0 - 70	
HSPF2	7.1		6.7	
Heating Power (W)	1189		2800	
Heat Pump Amps	5.3	4.7	12.8	11.1

Dimensions

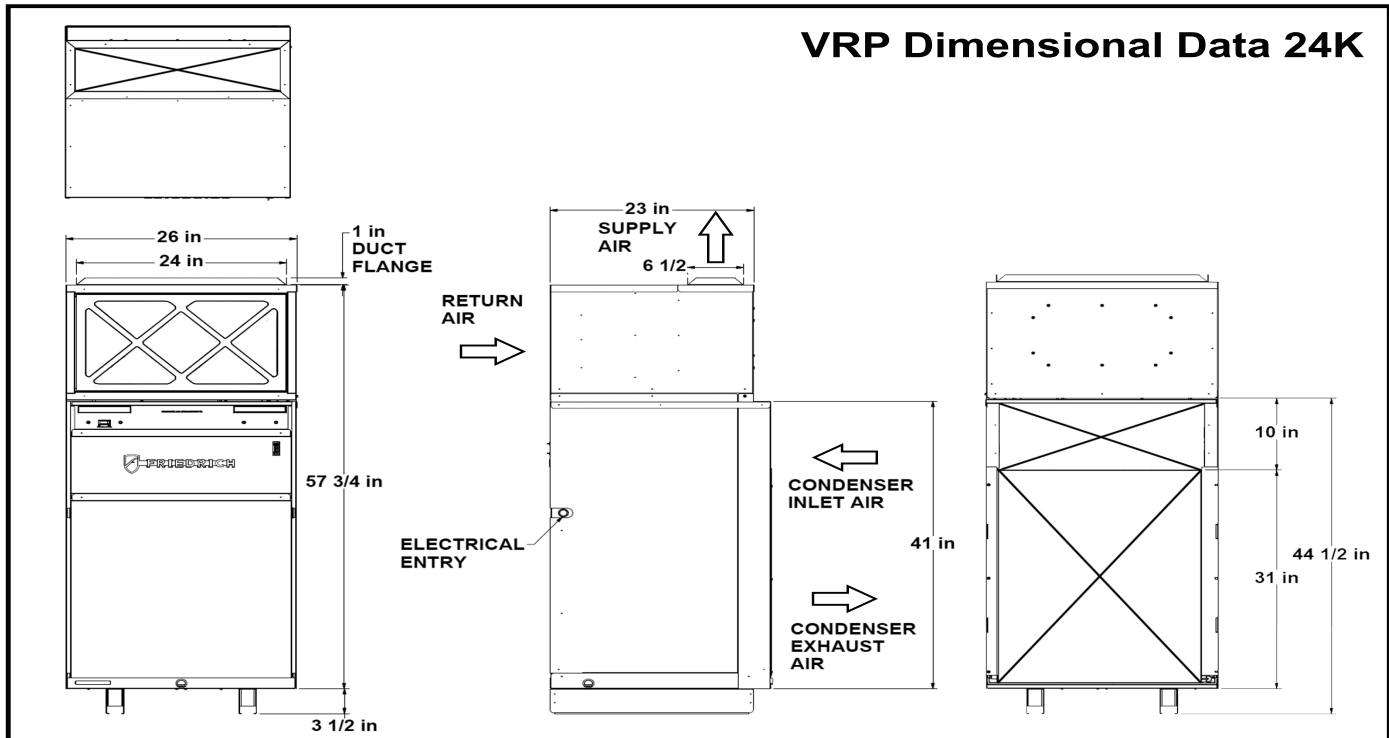
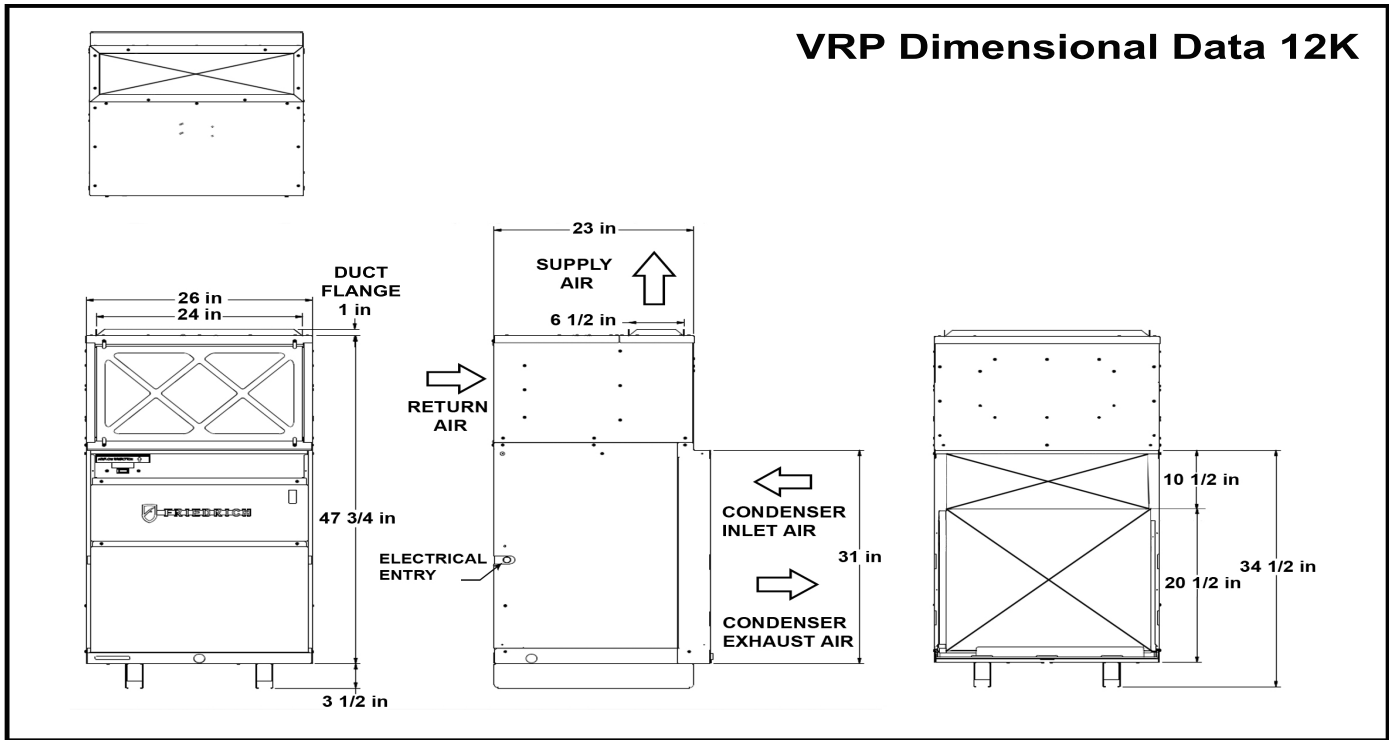

Model	VRP12K / VRP12R	VRP24K / VRP24R
Dimensions (W x D x H)	26 1/8" x 25 1/8" x 52"	26 1/8" x 25 1/8" x 62"
Shipping Dimensions (W x D x H)	28 1/8" x 27 3/8" x 54 1/2"	28 1/8" x 27 3/8" x 64 1/2"
Net Weight (lbs.)	215	255
Shipping Weight (lbs.)	276	316
R410A Charge (oz.)	49.8	68.3

Electrical Data

VRP Model	Voltage	Electric Heater Watts	Electric Heating Btu	ID Blower Amps	OD Blower Amps	Total Electric Heating Amps	MCA	MOP / MOCP
VRP12K	230	2250	7680	0.8	0.42	10.6	14.0	15
	208	1840	6280	0.8	0.42	9.6		
	230	2985	10180	0.8	0.42	13.8	18.0	20
	208	2441	8330	0.8	0.42	12.5		
	230	4362	14880	0.8	0.42	19.8	25.5	30
	208	3568	12170	0.8	0.42	18		
VRP12R	265	2242	7650	0.6	0.4	9.1	11.7	15
		2975	10150	0.6	0.4	11.8	15.1	20
		4347	14830	0.6	0.4	17	21.6	25
VRP24K	230	2985	10180	1.7	1.1	14.7	22.8	25
	208	2441	8330	1.7	1.1	13.4		
	230	4362	14880	1.7	1.1	20.7	26.7	30
	208	3568	12170	1.7	1.1	18.9		
	230	6888	23500	1.7	1.1	31.6	40.3	45
	208	5633	19220	1.7	1.1	28.8		
	230	9184	31340	1.7	1.1	41.6	52.8	60
	208	7511	25630	1.7	1.1	37.8		
VRP24R	265	2975	10150	1.7	1.1	12.9	22.5	25
		4347	14830	1.7	1.1	18.1	23	25
		7500	25590	1.7	1.1	30	37.8	40
		10000	34120	1.7	1.1	39.4	49.6	50

MCA = Minimum Circuit Ampacity

MOP / MOCP - Maximum Overcurrent Protection / Breaker Size

Minimum Circuit Amps (MCA) and MOCP values in the above table are calculated in accordance with The NEC Article 440

Electrical Requirements	
Wire Size	Use ONLY wire size recommended for single outlet branch circuit.
Fuse/Circuit Breaker	Use ONLY type and size fuse or HACR circuit breaker indicated on unit's rating guide. Proper over current protection to the units is the responsibility of the owner.
Grounding	Unit MUST be grounded from branch circuit to unit, or through separate ground wire provided on permanently connected units. Ensure that branch circuit or general purpose outlet is grounded.
Wire Sizing	Use recommended wire size given in tables and install a single branch circuit. All wiring must comply with local and national codes. NOTE: Use copper conductors only.

Electrical Rating Table

NOTE: Use copper conductors **ONLY**. Wire sizes are per NEC.

Recommended Branch Circuit Sizes*	
Nameplate Maximum Circuit Breaker Size	AWG Wiring Size**
15A	14
20A	12
30A	10

AWG - American Wire Gauge

* Single circuit from main box.

** Based on 100' or less of copper, single insulated conductor at 60° C

NOTE: All field wiring must comply with NEC and local codes. It is the installer's responsibility to ensure that the electrical codes are met.

Air Flow Data

Indoor CFM & External Static Pressure

Air Flow Data														
Model	Speed Select	Airflow Setting	Static Pressure (in. WC)											
			0.00	0.05	0.10	0.15	0.20	0.25	0.30	0.35	0.40	0.45	0.50	
VRP12K/R*	1	High	540	480	430	400	340	270	200	140	100			
		Low	350	290	220	120								
	2	High	630	580	535	480	420	370	330	290	240	180	100	
		Low	390	330	260	200								
	3	High	650	620	575	540	490	455	420	355	330	280	200	
		Low	425	370	315	260	195	130						
	4	High	710	670	610	580	535	490	470	440	415	320	240	
		Low	490	430	400	320	290	220	120					
	5	High	780	750	700	655	620	570	540	515	470	440	400	
		Low	540	480	430	400	340	270	200	140	100			
VRP24K/R*	1	High	780	750	710	670	635	610	580	550	510	460	415	
		Low	585	540	490	460	420	370	310	260	200	130		
	2	High	810	770	740	710	670	640	615	580	555	510	480	
		Low	630	580	535	480	420	370	330	290	240	180	100	
	3	High	910	880	860	810	795	780	755	730	695	650	590	
		Low	680	650	620	560	520	480	435	380	340	280	220	
	4	High	980	940	915	890	860	835	805	790	770	750	705	
		Low	770	740	690	650	610	560	530	500	460	420	390	
	5	High	1060	1020	1000	980	965	940	925	900	880	845	800	
		Low	810	770	740	710	670	640	615	580	555	510	480	

* Rated to 0.5" ESP High and includes factory provided filter

VRP Configurator

All units are shipped with Speed Select 1 High as the default airflow. In higher static applications, it is necessary to increase the airflow to a higher Speed Select setting. Using the VRP Configurator tool and associated instructions, the speed settings can be changed on units with a firmware 3.7.0.0 or later.

Condenser CFM & External Static Pressure

VRP is designed to install through an exterior wall with a plenum (VRPXWP*-8, VRPXWP*-14) and a Friedrich external louver .

If the Friedrich designed plenum and louver combinations are not used, the selections and design must be evaluated by Friedrich to ensure the total pressure drop does not exceed the maximum allowable limits.

Condenser External Static Pressure			
VRP Model	Design		Max
	CFM	ESP ("WC)	ESP ("WC)
VRP12K/R	700	0.03	0.1
VRP24K/R	1150	0.02	0.11

VRP® Required Minimum Clearances

Building Exterior Unit Opening Requirements

VRP units must be installed on an outside wall. Confined spaces and/or covered areas should be avoided. Units must be installed no closer than 12" apart when two units are side by side. If three or more units are to operate next to one another, maintain a minimum of 60" between units or pairs of units (Figure B). If more than two units are sharing a floor with adjacent, outset units, a minimum distance of 64" must be kept between units (Figure C). Also, a vertical clearance of 60" must be maintained (Figure A) between units. Units installed on the bottom floor must be mounted at least 6" off of the ground. If two units are facing each other, a minimum distance of 108" must be kept between units (Figure D).

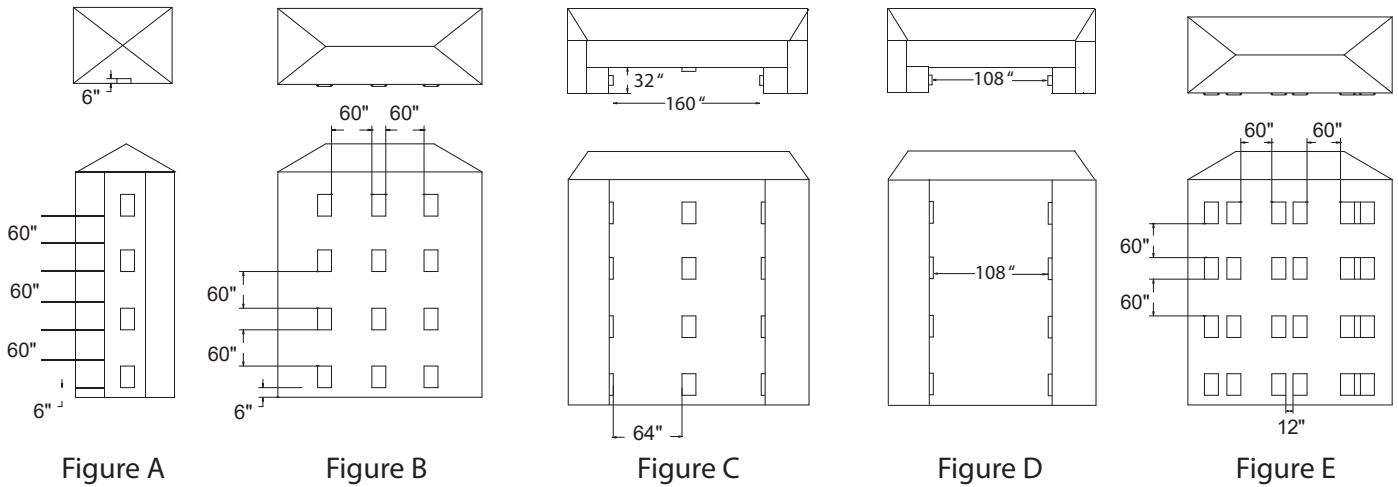

Grill Clearance Requirements

Where obstructions are present use the following guidelines for proper spacing from the VRP exterior louvered grill. Friedrich recommends that ALL obstructions are a minimum of 72" from the exhaust.

For minor obstruction(s) such as lamp poles or small shrubbery, a clearance of 24" from the outdoor louver must be maintained.

For major obstructions such as a solid fence, wall, or other heat rejecting devices like a condensing unit, a minimum distance of 72" must be kept.

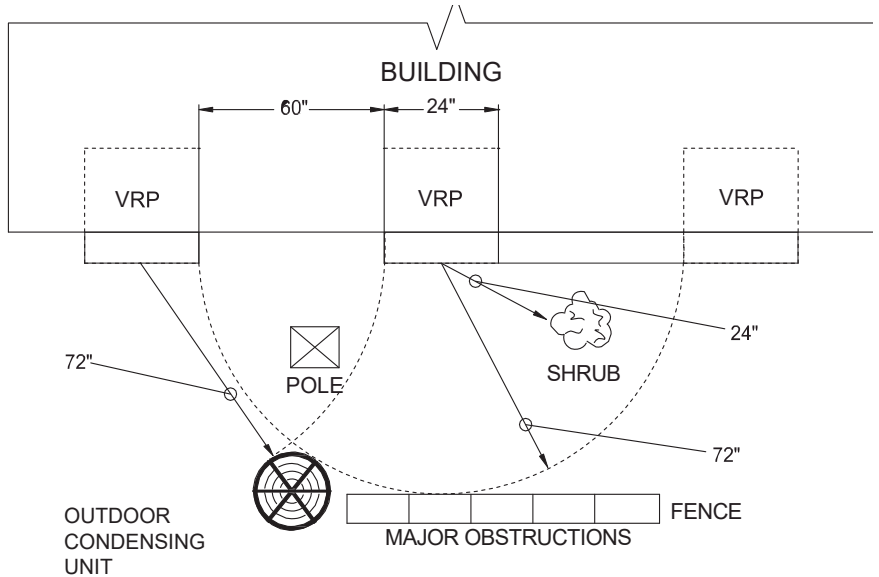

The example pictured above is for reference only and does not represent all possible installations. Please contact Friedrich Air Conditioning for information regarding effects of other installation arrangements.

Installation Orientations

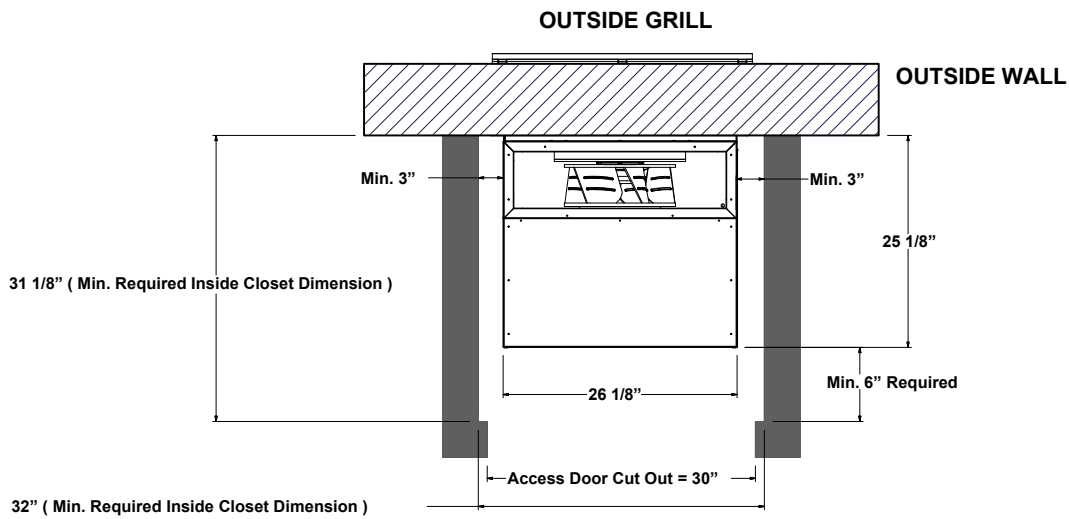

Front Installation-Top View

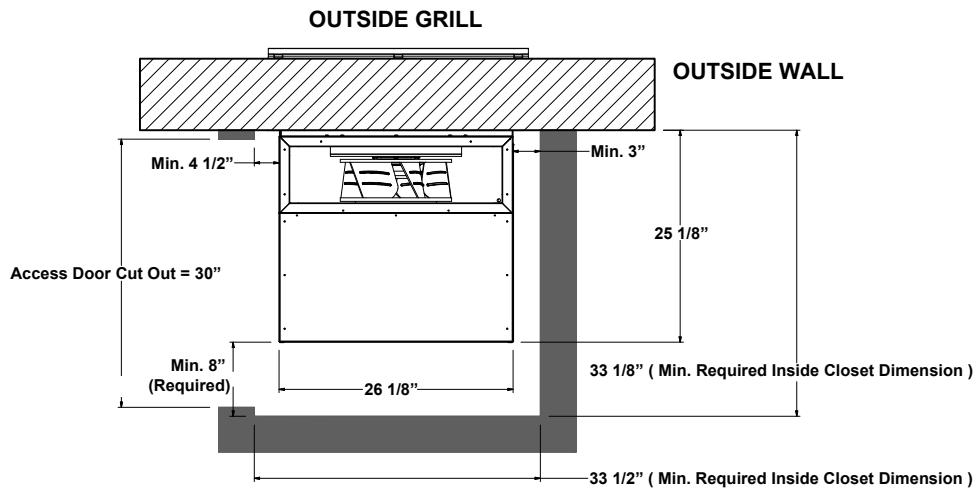

Left Installation-Top View

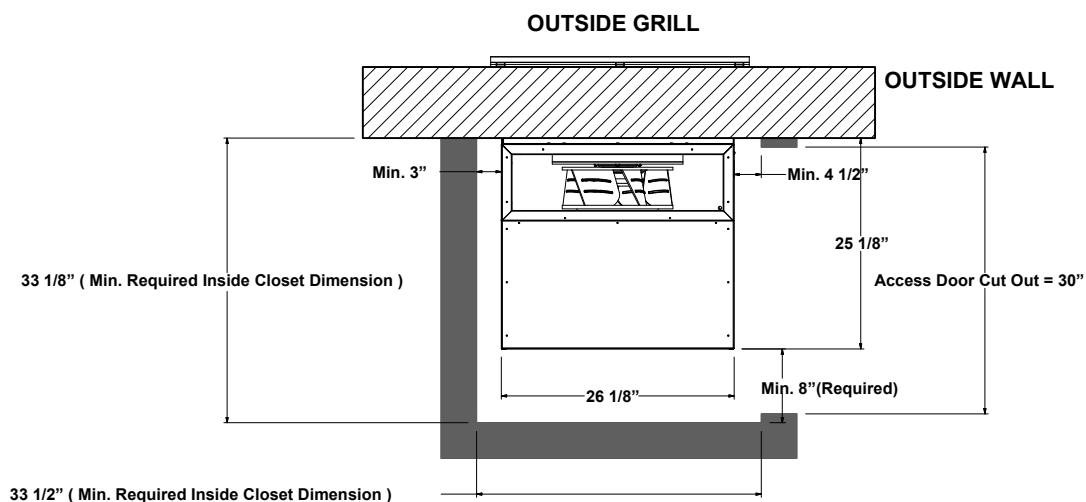

Right Installation-Top View

While all installation orientations are feasible, for the ease of installation and serviceability, Friedrich recommends Front Installation.

Exterior Wall Opening Dimensions

Exterior Wall Rough Opening Dimensions		
Unit	Width	Height
Compact (VRPXWPA-*)	28 1/8"	32 1/4"
Standard (VRPXWPB-*)	28 1/8"	42 1/4"

Compact (A) configuration is for VRP12K/R units only. Standard (B) configuration is for VRP12K/R and VRP24K/R units. VRP12K/R unit can be adapted to a Standard plenum with a factory provided adapter. Ensure that the correct wall plenum is selected based on unit configuration.

NOTE: The distance between the rough opening and the finished floor/platform must be 3".

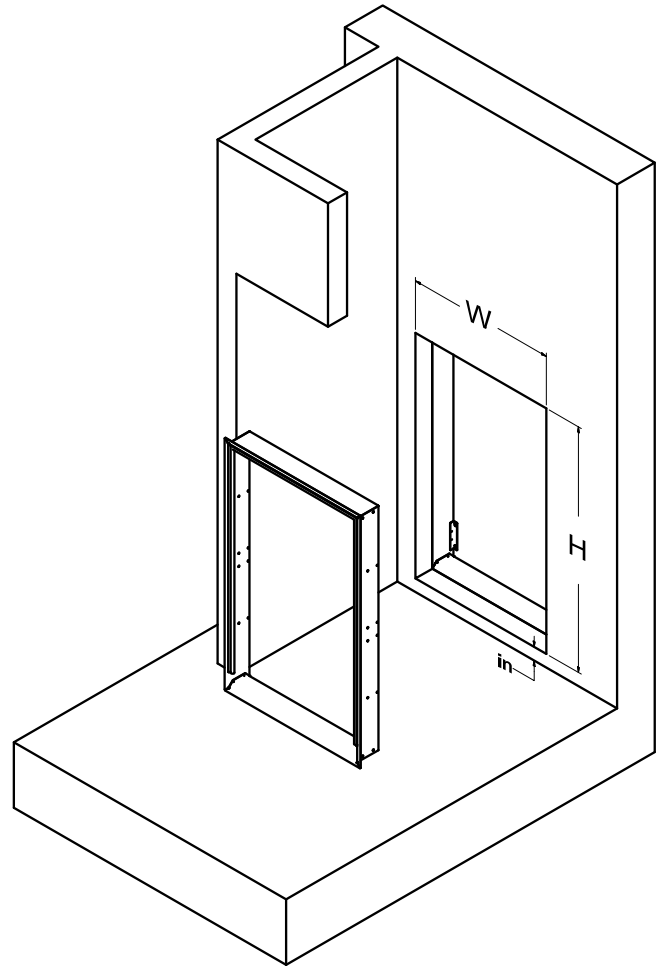

Interior (Closet) Wall Opening Dimensions

Return Air Access Door Wall Cut-Out

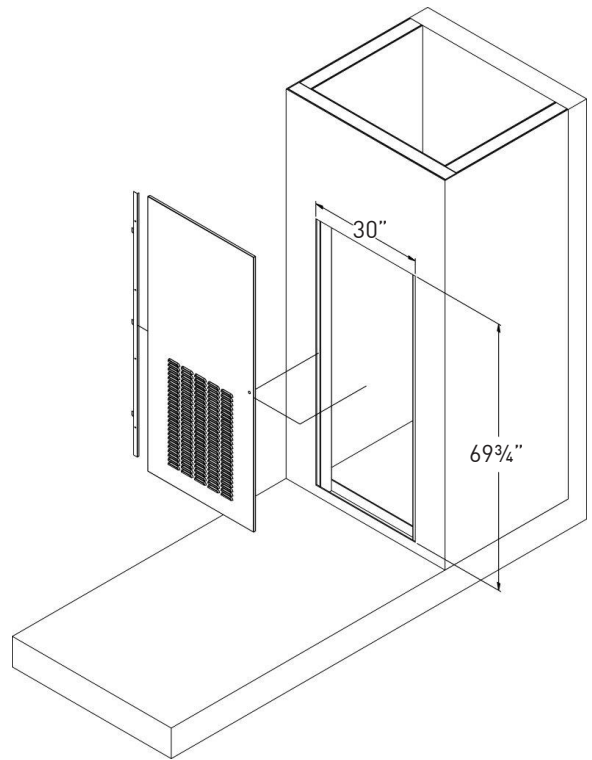

NOTE: To maintain ease of removal and serviceability, if the unit is installed on a platform ensure that the total height of the unit from the floor does not exceed the height of the interior rough opening.

Preliminary Plumbing

Standard (Front Install)

The image to the right shows the installation closet for the standard (Front Install) configuration (where the wall plenum is opposite the service access door).

A drainage system is required, and should provide a "P-trap" to prevent undesirable waste gas from entering into the residential area. This is represented by a vertical standpipe in the image shown (Detail A), but other solutions are possible and are at the discretion of the building designer and contractor.

The near wall has been trimmed away at the door centerline to permit full view of the installation.

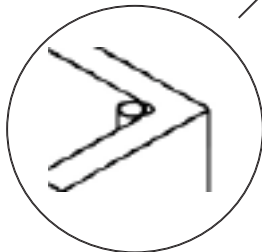
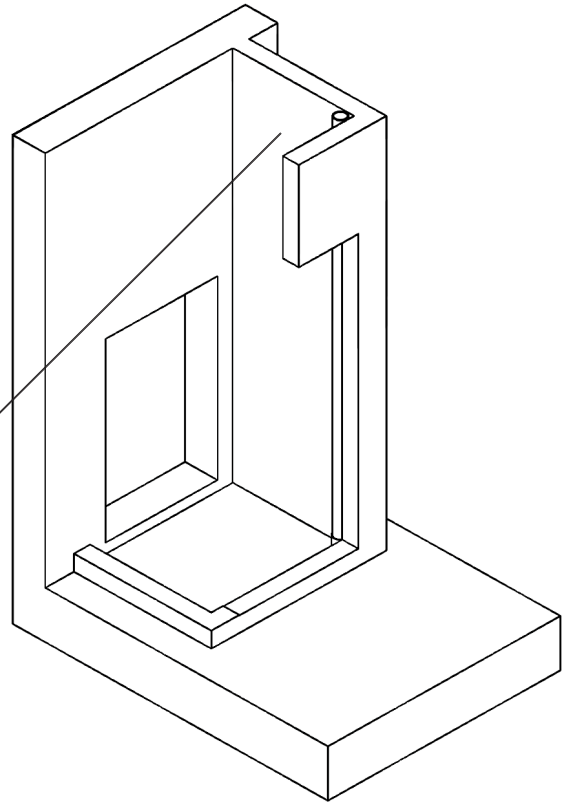

Detail A

Wall Plenum Installation

Parts included in Plenum kit:

Outside Plenum (Part A)
Inside Plenum (Part B)

Divider (Part C)
Baffle (Part D)

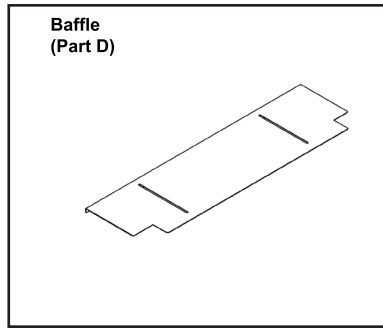
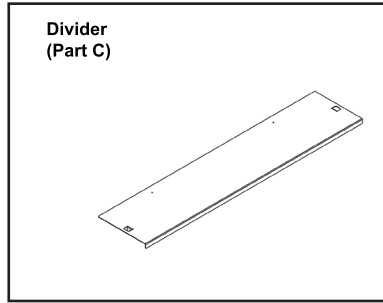
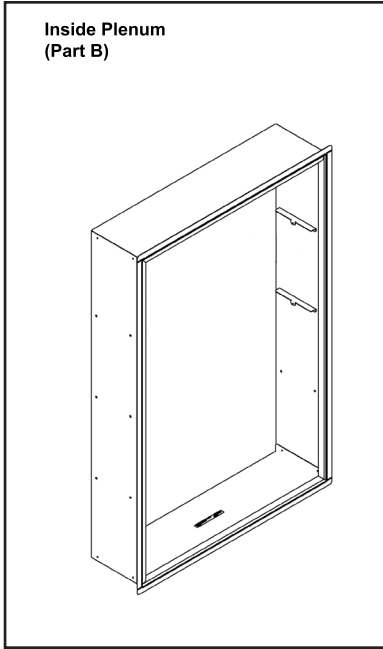
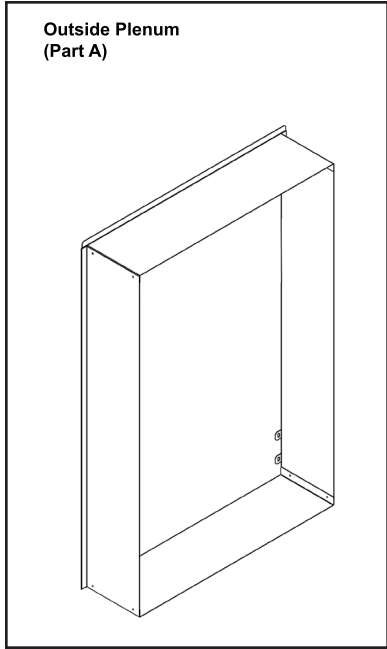

Field Supplied Parts:

Sealant, attachment screws, and flashing are field supplied. Silicone sealant is recommended.

VRPXWPA-8, VRPXWPB-8 adjust for walls up to 4" - 8" thick.

VRPXWPA-14, VRPXWPB-14 adjust for walls up to 8" - 14" thick

All installations are similar.

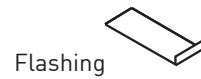
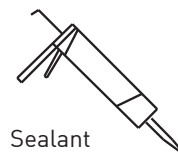

1"-3" Screws to attach the plenum assembly to the wall studs

Wall Plenum Installation

Step 1 - Outside Wall Plenum Half

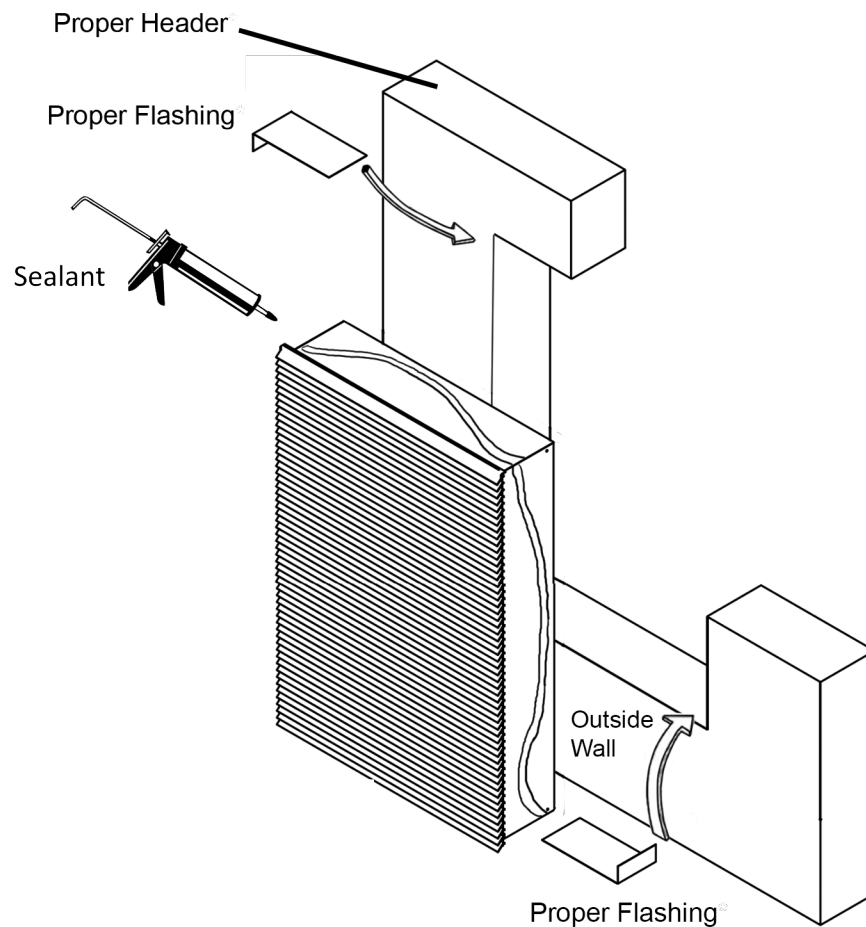

Note: The wall plenum is not designed to carry any structural load. A load bearing header must be built above the rough opening.

- 1) Prepare the rough opening. The rough opening should be lined with metal or wood. The plenum will warp if sealed against concrete or brick.
- 2) Dry fit the outside plenum half into the rough opening and check the fit and level.
- 3) Remove the outside plenum half, flash the rough opening to ensure proper fit and level.
- 4) Pre-installing the exterior louver (VRPXALA/B) as shown above is optional (See Page 17).
- 5) Apply sealant to the outside plenum half and insert into the rough opening to ensure a water-tight seal. Ensure that the outside plenum half is securely attached to the framed opening.
- 6) Place the plenum divider (Part C) on the appropriate divider mounting tabs located on the inner perimeter of the outside plenum half based on unit size (Compact/Standard).

Wall Plenum Installation

Step 2 - Inside Wall Plenum Half

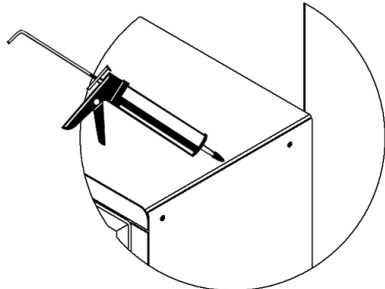

Detail A

Apply Sealant to all 4 flange corners and unused holes.

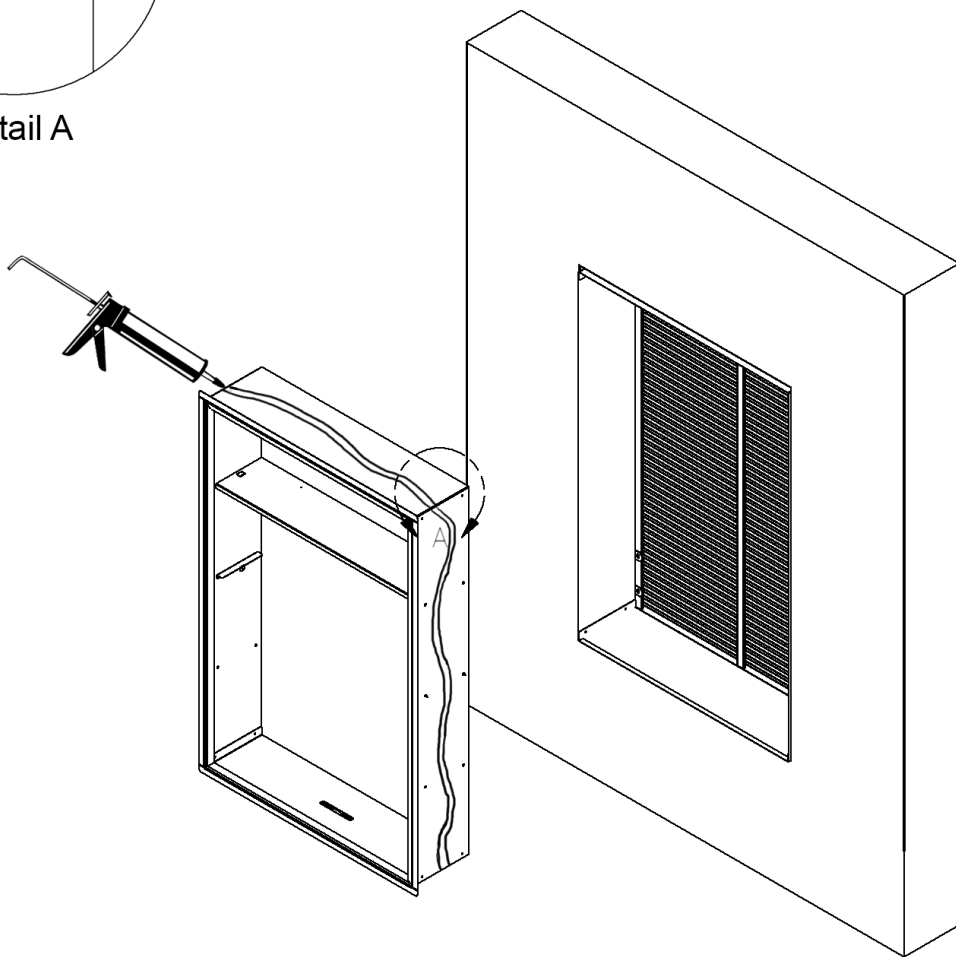

- 1) Apply sealant to all 4 flange corners and unused holes. See Detail A.
- 2) Place the baffle (Part D) on the appropriate baffle mounting tabs located on the inner perimeter of the inside plenum half based on unit size (Compact/Standard).
- 3) Flash the inside of the rough opening to ensure the proper fit and level.
- 4) Insert inside plenum half (Part B) into Outside Plenum Half (Part A). Ensure that Part A does not back out of the rough opening.
- 5) Remove the inside plenum half.
- 6) Apply sealant to the outside plenum half and insert into the rough opening to ensure a water-tight seal.

Wall Plenum Installation

Step 3 - Inside Wall Plenum (cont.)

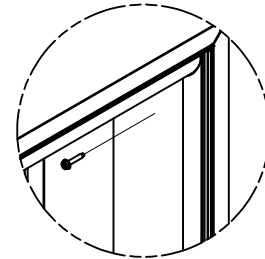
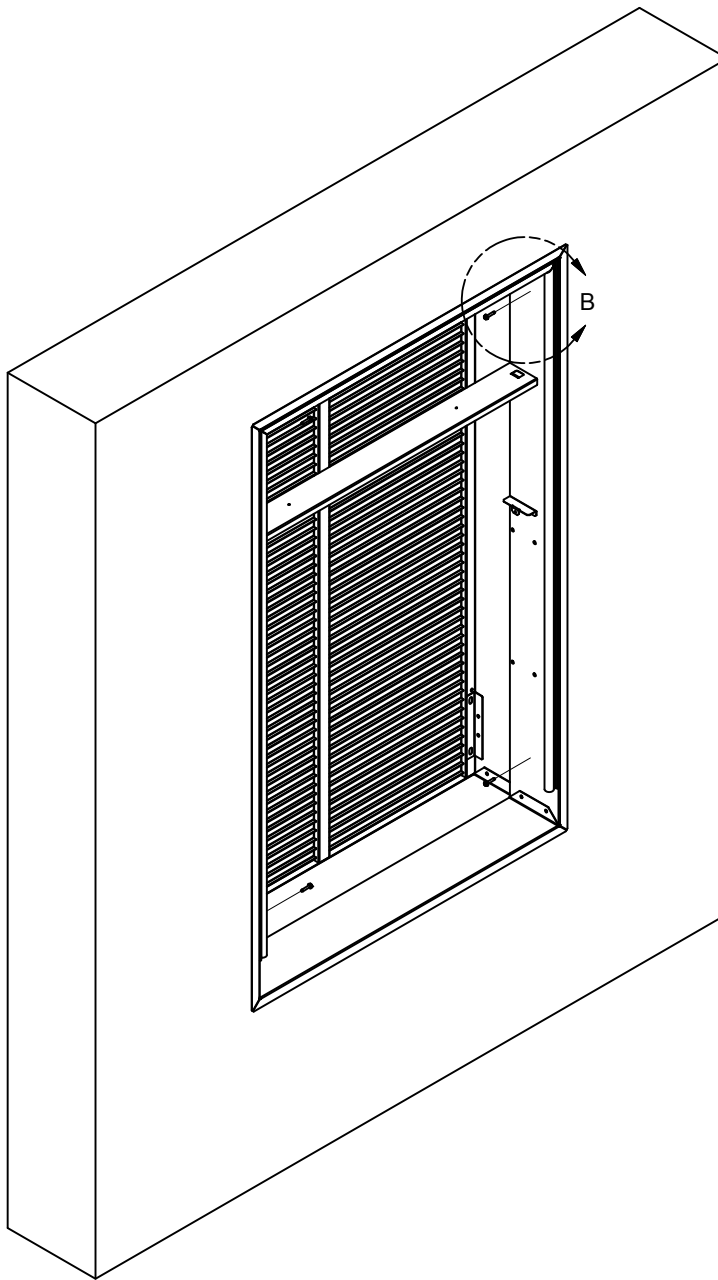

Detail B

Note: Do not place any screws, fasteners, or penetrating holes through the top or bottom of the plenum assembly.

- 1) Drill pilot holes on the interior of the inside plenum half (Part B) as show in Detail B. Pilot holes should be located approxiamtely 4" from the top and bottom of the inside plenum half, on both the left and right sides.
- 2) Install fasteners through each pilot hole. Fastener must pass through both Part A and Part B. If the inside and outside plenum halves do not overlap at fastening point, be certain to drill extra holes where needed to secure both Part A and Part B to the rough opening.

Louver Installation

Installation of the louver PRIOR to Wall Plenum Installation

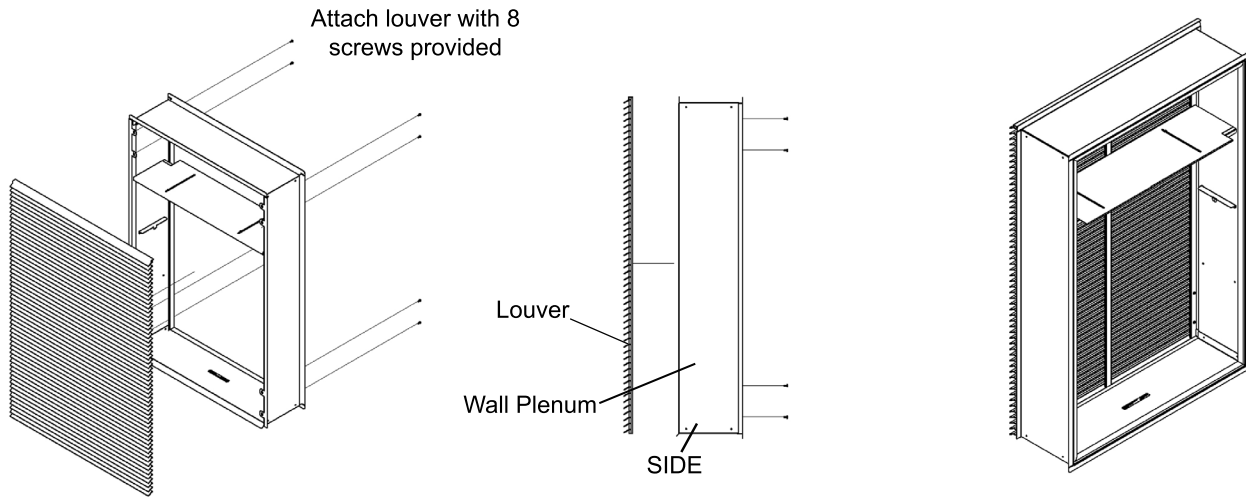

NOTE: Louvers & Drip Ledge orientation is down

- 1) Hold the louver up to the outside plenum half (Part A) and line up the louver top with the very top edge of the $\frac{3}{4}$ " flange.
- 2) Line up the wall plenum holes with the threaded holes in the louver and securely tighten fasteners.

Installation of the louver AFTER the installation of wall plenum on elevated floors

From the interior of the utility closet:

- 1) Tie a rope or tether to the architectural louver and the divider in the wall plenum to prevent it from falling if dropped.
- 3) Turn the louver sideways and push the louver out below the divider in the wall plenum.
- 4) Pull the louver back against the wall plenum and align the holes.
- 5) Insert and tighten all eight provided fasteners. When the louver is secured, remove the safety tether.

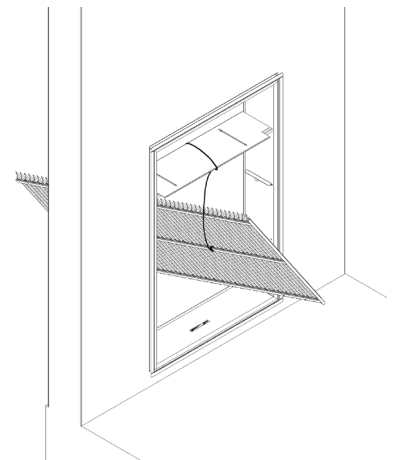

Final Wall Plenum and Architectural Louver Installation

Plenum Divider Extension Plate (Baffle)

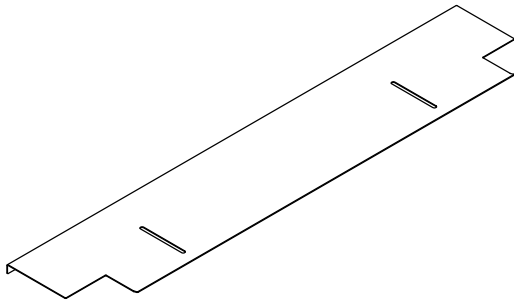

Plenum Divider Extension Plate Installed into Full Plenum Assembly

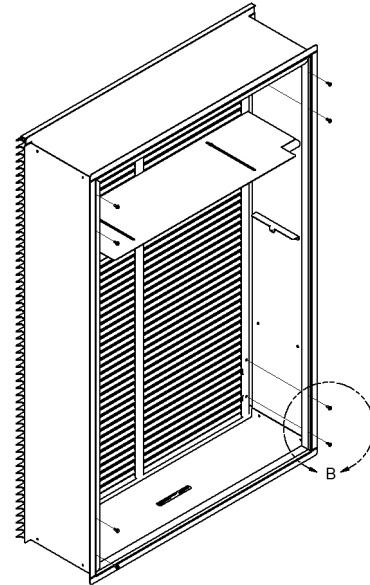

Ensure that the weather strip is undamaged and provides a continuous seal around the inner perimeter of the plenum.

Apply silicone grease or other non-petroleum-based lubricants to the weather strip to enhance the sealing capability of the weather strip and ease installation of the air conditioner chassis.

- 1) Install the plenum adjuster plate. Ensure the exterior edge is seated against the inside of the architectural louver.
- 2) Secure the plenum divider extension plate to the architectural louver using the two provided screws.
- 3) Use tape and sealant to seal any gaps.

Unit Installation

Unit Placement Prior to Installation (Front-Install Configuration)

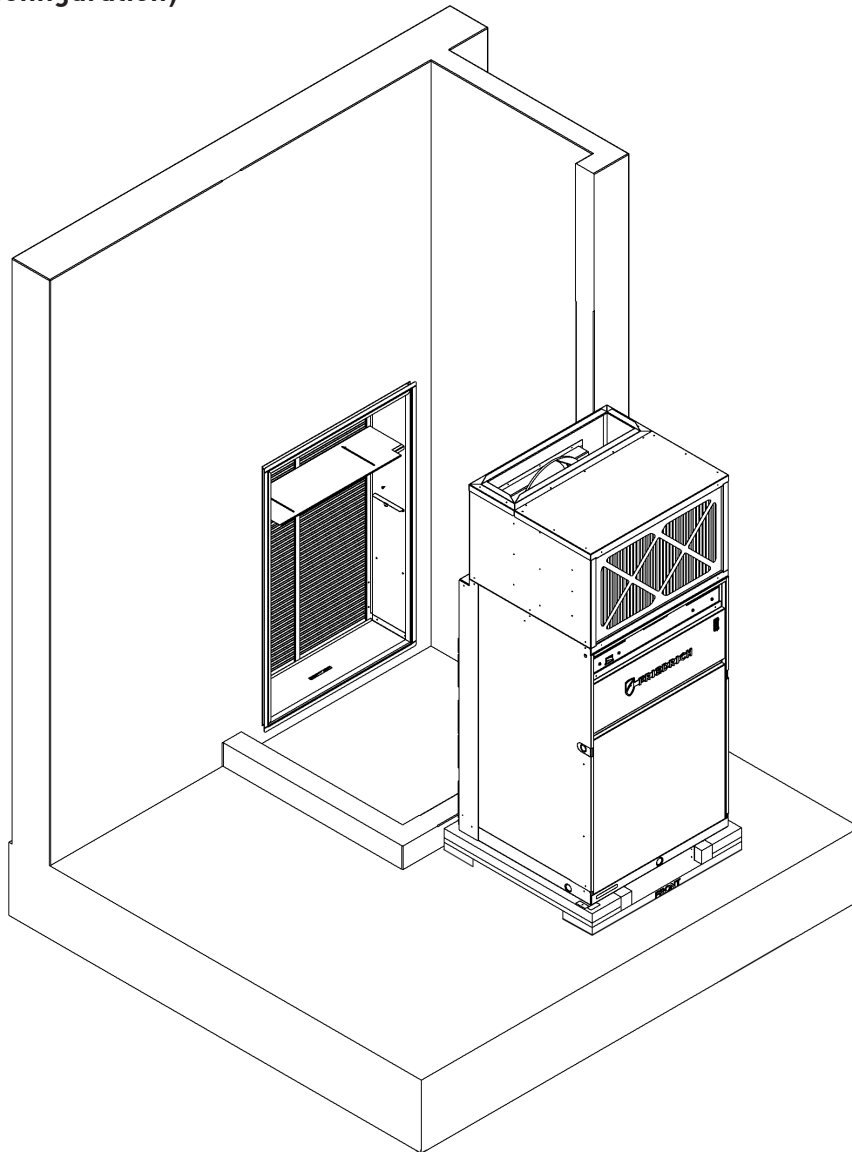

All louver, plenum, rough plumbing, and rough wiring steps must be complete prior to final installation of the air conditioning chassis.

Final Unit Installation Overview

Unit Final Placement - Front Install

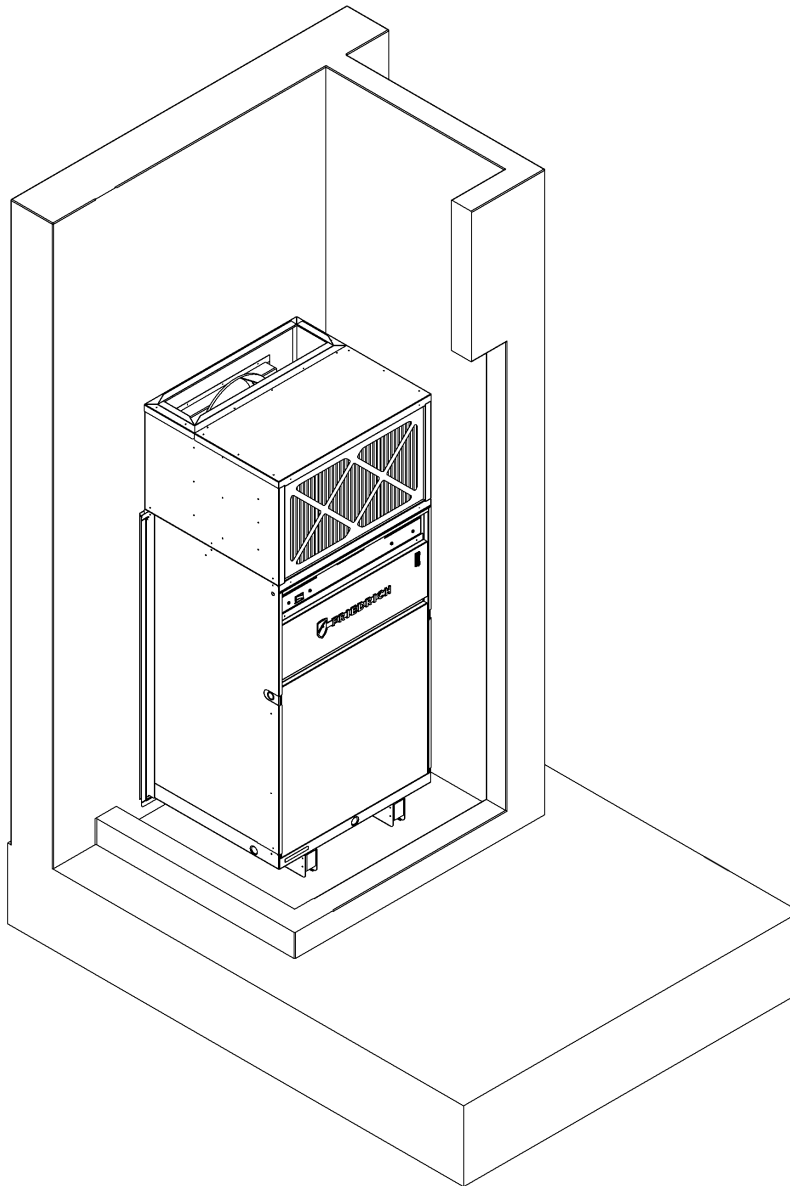

- 1) Ensure that power is off at the junction box feeding power to the air conditioner until all process steps are completed.
- 2) Move the unit from the shipping base and onto the installation site.
- 3) Insert the unit's rear extension into the wall plenum. There should be approximately 2" of penetration of the unit into the wall plenum, resulting in a complete seal all around.
- 4) Identify the appropriate drain port to use and complete plumbing (See Page 22).
- 5) Attach the ductwork to the unit at the supply-air outlet and ensure the seal is air tight (See Page 23).
- 6) Wire and connect the wall controller (See Pages 24-27).
- 7) Connect the main power (See Page 28).

Side Configuration Installation

**Left Install VRP Unit
Prepared for Installation**

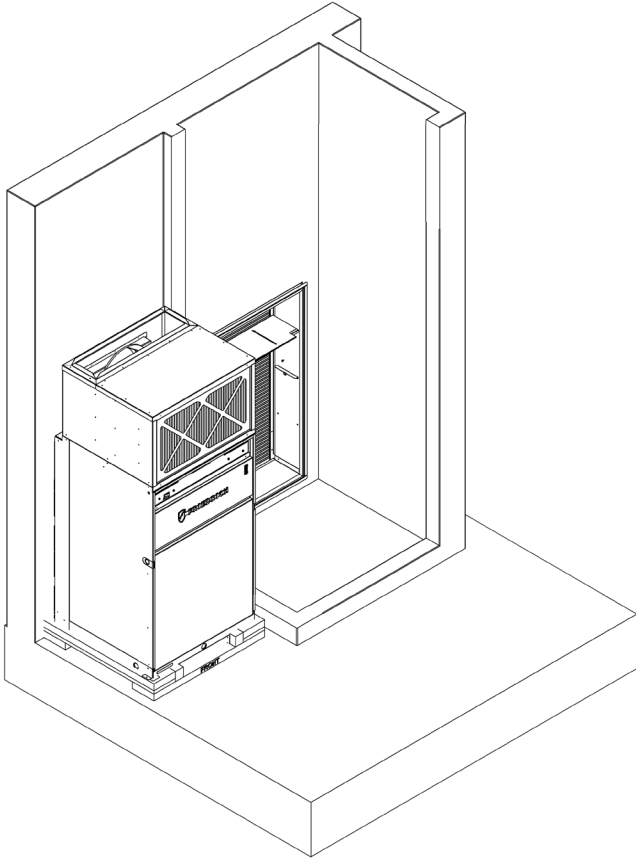

**Left Install VRP Unit
in Closet (Fully Installed)**

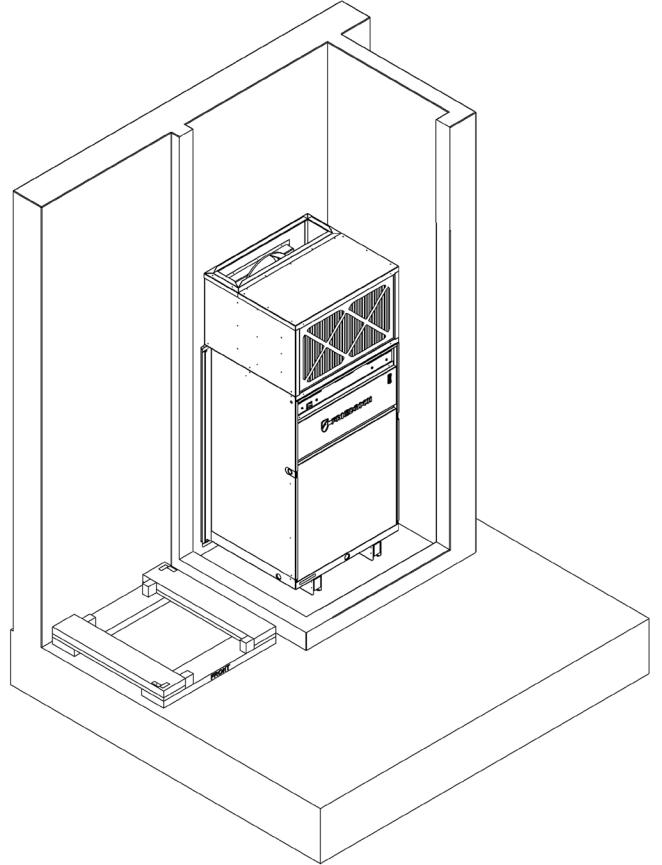

For side-install applications, place the unit adjacent to the closet and slide it in. Then, slide the unit backward into the plenum.

Final Drain Installation

Unit Drain Installation

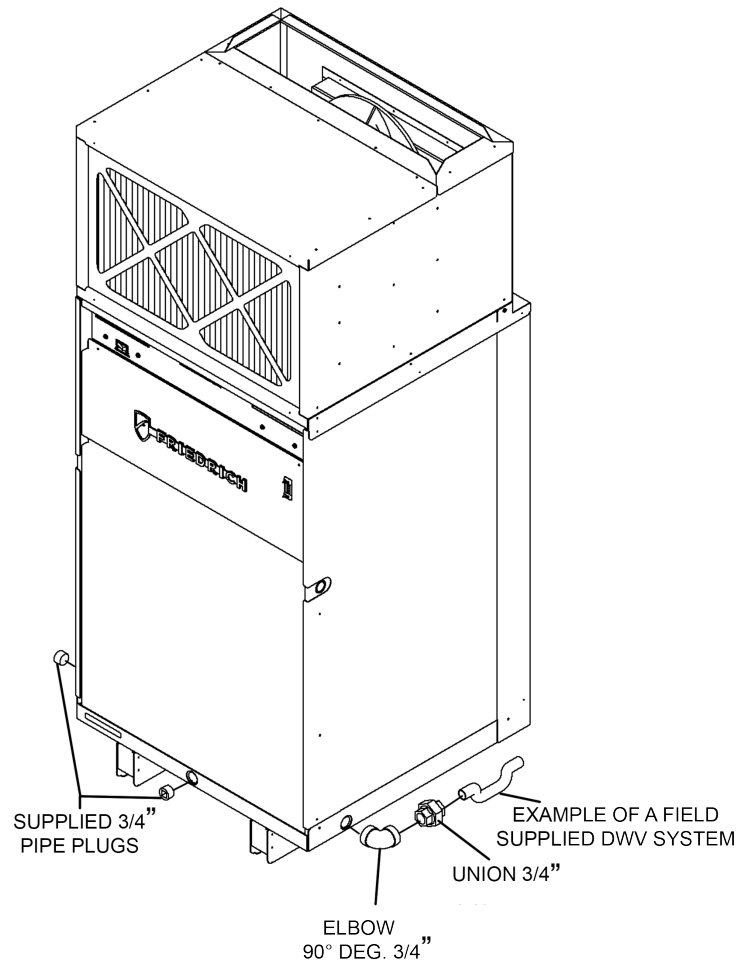

NOTE: Failure to follow the following procedures may result in serious property damage. A field supplied secondary condensate pan may be required. Check with local codes. In case of drainage system blockage, the unit base will allow excess water to flow out of the unit through the plenum and the architectural louver. It is critical to ensure that the drainage path is not blocked or obstructed in any way during installation.

- 1) Connect the supplied drain kit must be connected to one of the three (left, right or rear) 3/4" FPT connections on the unit basepan. Use of rear fitting without connection to DWV system (drain, waste, vent) may result in staining of the outside wall.
- 2) Insert the provided 3/4" nipple into the determined connection using field-supplied Teflon tape or pipe joint compound.
- 3) With the slip end of a 3/4" union, connect to the nipple with Teflon tape or pipe joint compound.
- 4) Hand-tighten all fittings to prevent damage to unit or fittings.
- 5) Install a field-supplied drain system to the slip end of the union. A trap is required and drain connections should be connected to building DWV system. Pitch the drain line of a 1/4" downward slope for every foot (1') of lateral horizontal run to the DWV.
- 6) Plug the two unused connection ports with the two provide 3/4" pipe plugs and field-supplied Teflon tape or pipe joint compound. High tighten to prevent damage to the unit or fittings. Do not thread metal or copper pipe fittings directly into unit.
- 7) Check the system for leaks.

Ductwork Installation

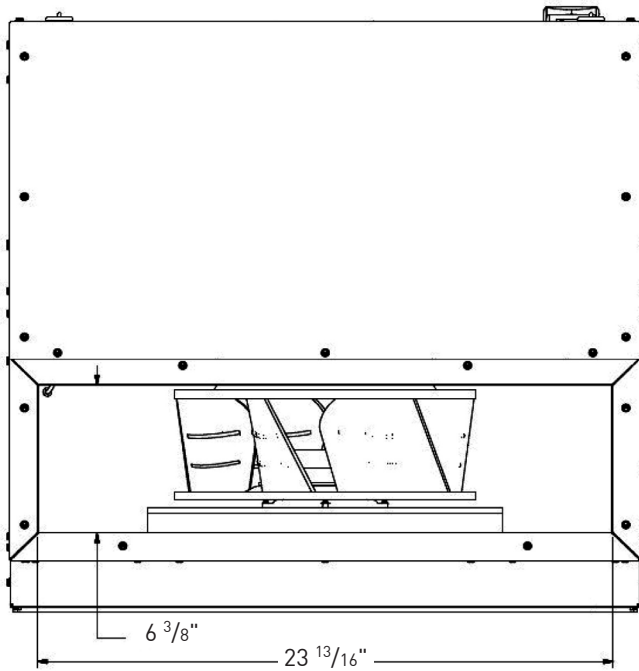

Supply air duct connection is the responsibility of the installer and should be installed per industry best practices.

Sheet metal or duct board may be used for the transition from the discharge to 10" or larger diameter flexible ducting.

Avoid sharp transitions in the ductwork to ensure optimal indoor blower performance.

Allow at least 12" (18" preferred) from the discharge of the unit to the final reduced-size transition to support optimal efficiency of the blower system.

Wall Controller Installation

Proper Wiring of VRP unit to Wall Controller

Use shielded and stranded CAT 6 cable with twisted pairs to wire the wall controller. Use the wire colors with the corresponding terminals on the wall controller to the VRP unit as shown in the table below.





Wire Color		Label
Orange		V +
Green / White		
Brown		D +
Blue / White		
Blue		D -
Brown / White		
Green		V -
Orange / White		
Ground Shield Wire		GND

Table shows which wire pairs go with which screw terminal.

Wall Controller Installation

Wiring to the VRP Unit

- A. Strip the wire ends to 9/16" (15 mm).
- B. Insert the wire pairs into terminals as shown below.
- C. Insert ground shield wire into ground terminal (marked with a ground symbol).
- D. Tighten the screws to secure the wires to the corresponding terminals.
- E. Pull the wires to check that they are securely affixed to the terminal block.

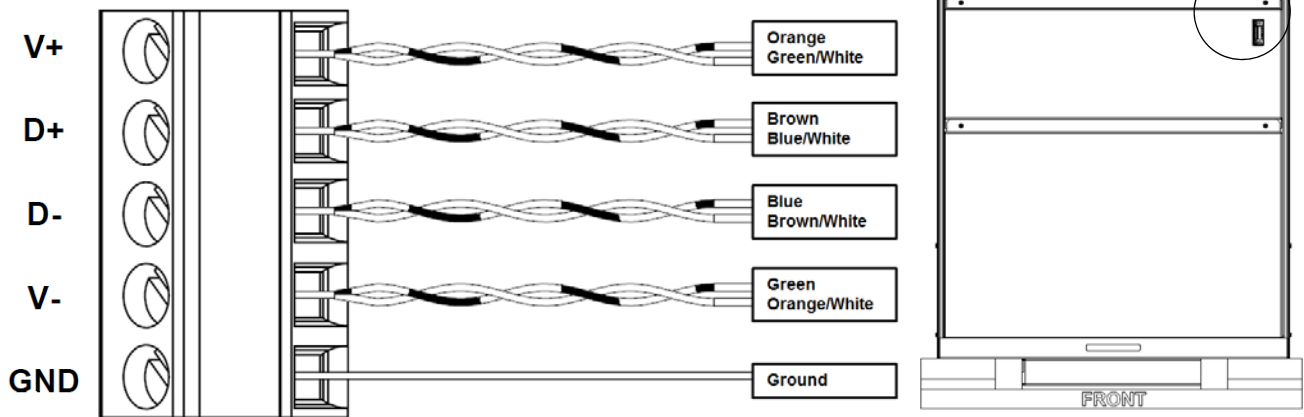

Electrical Installation

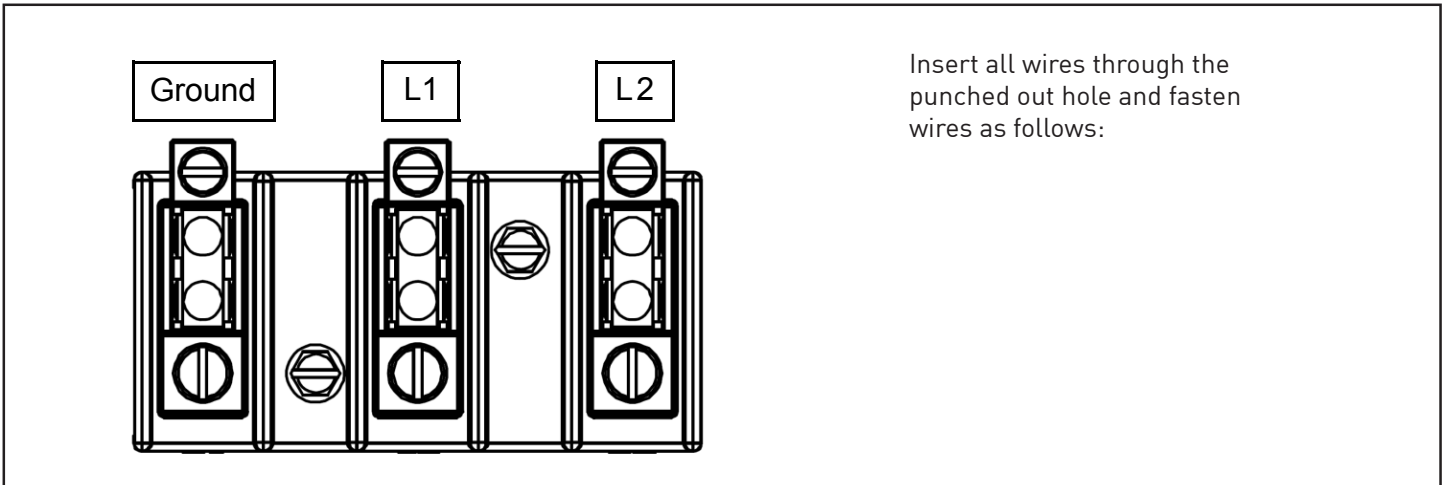
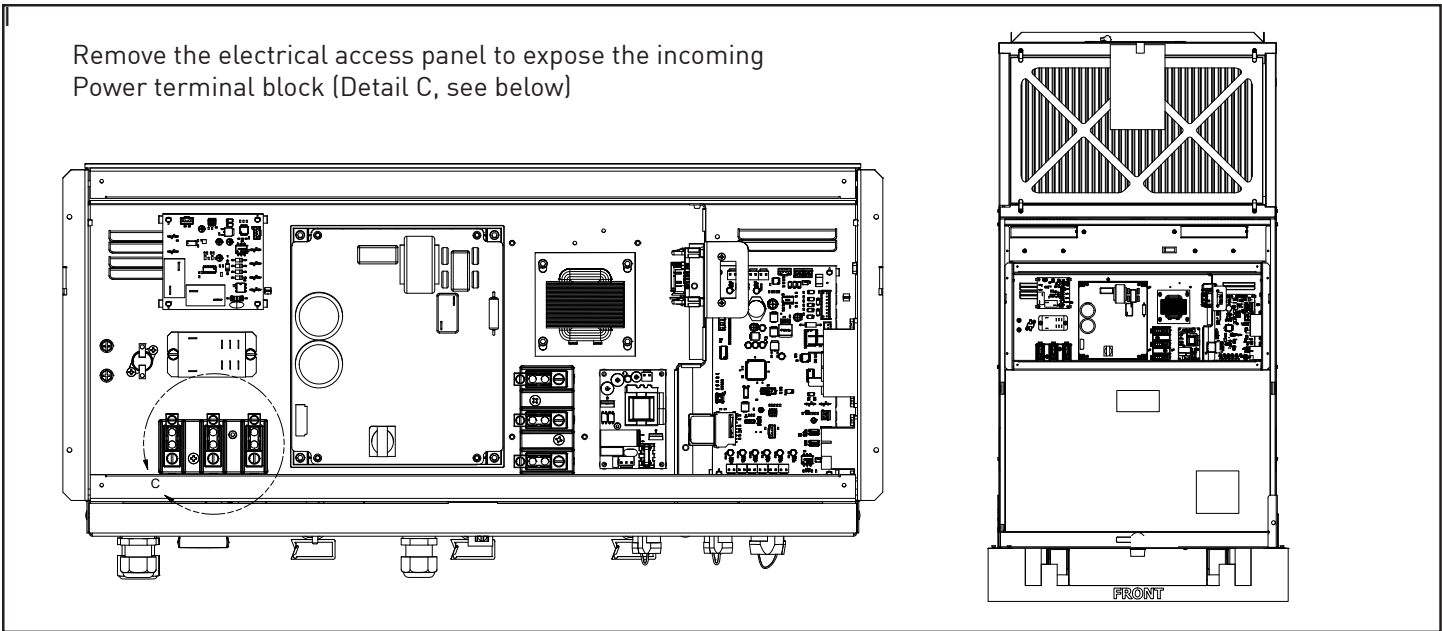
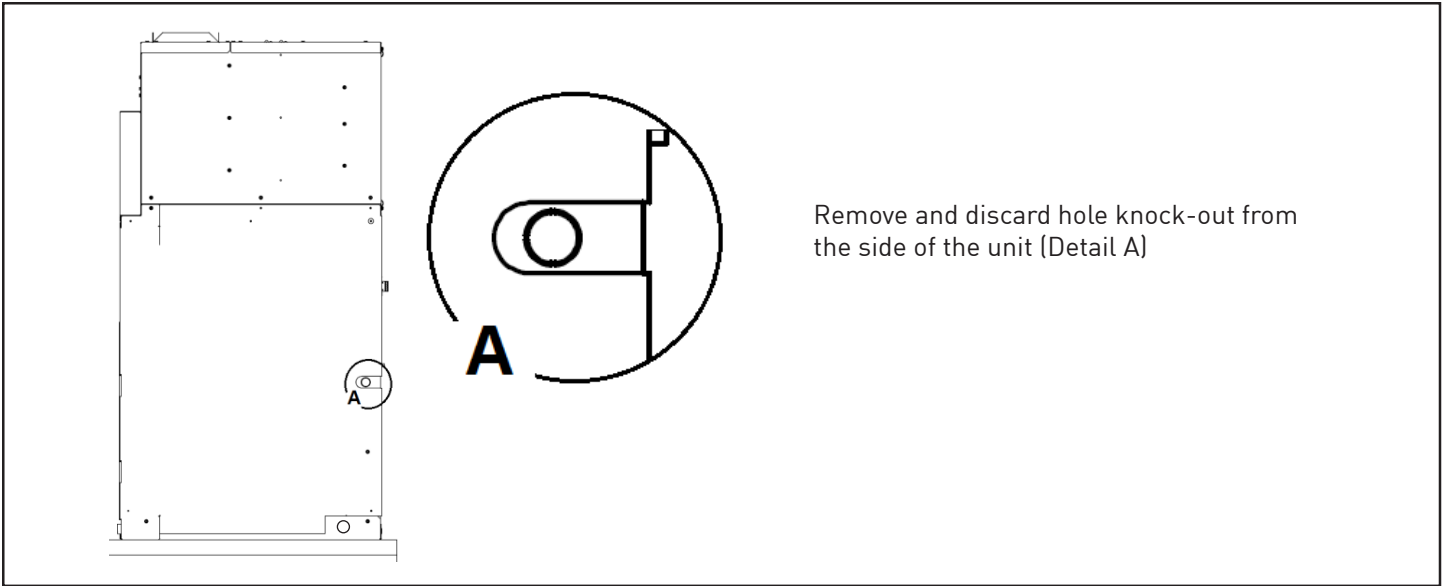

Return Air Door Installation

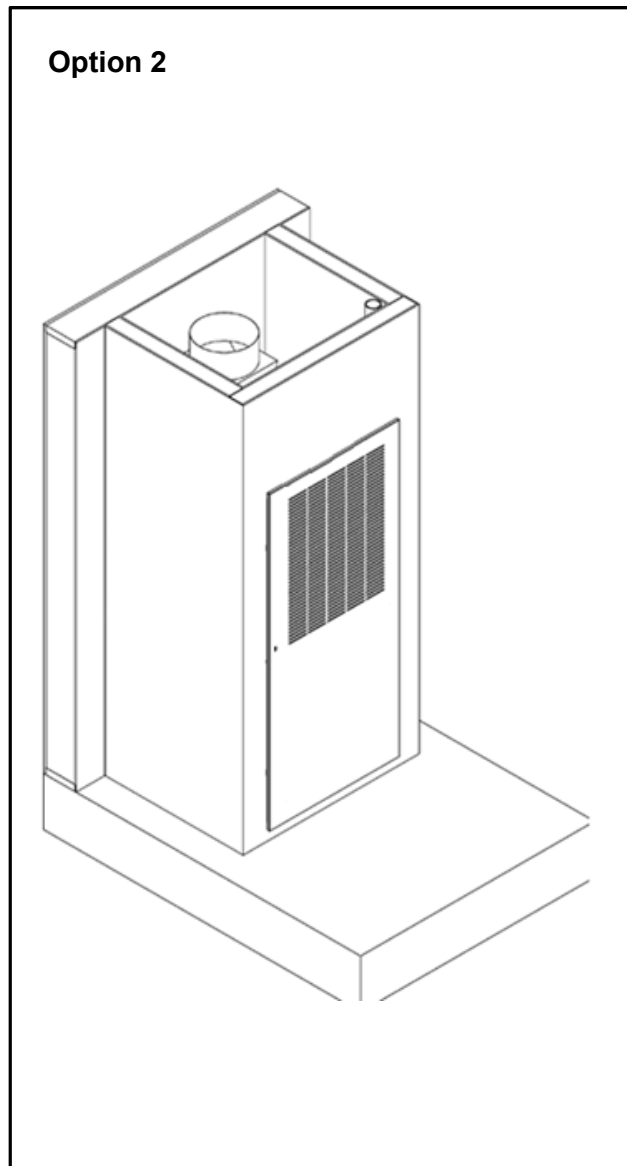
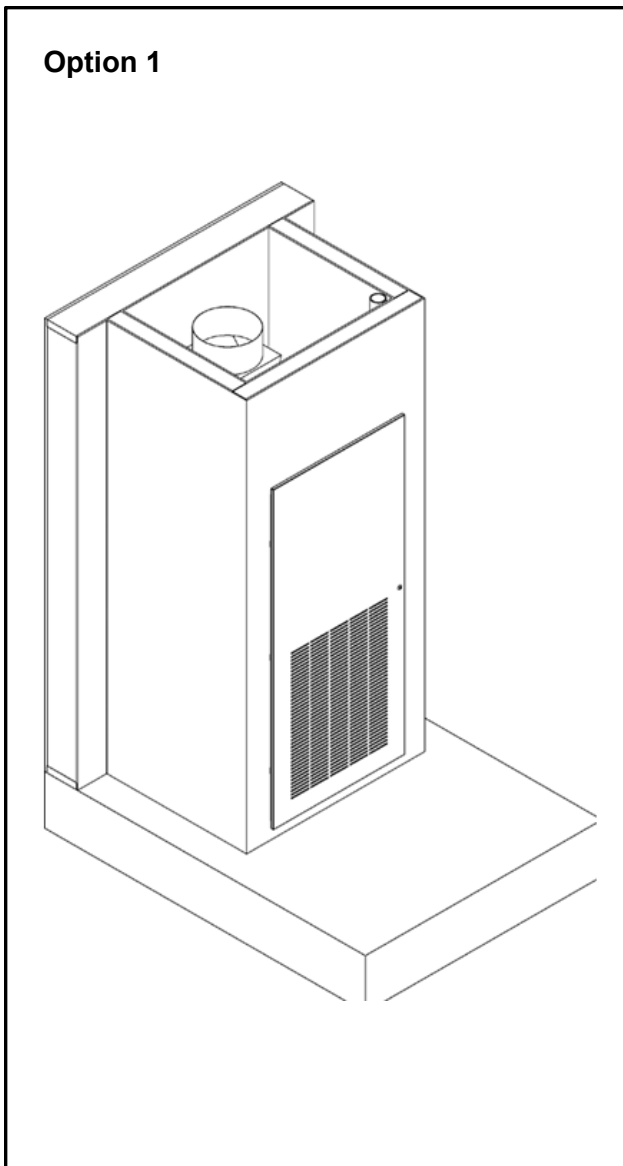

The door panel is supported along one edge by the provided hinge. The opposite edge has a latch which secures the panel to the adjacent framed structure.

The kit contains hinge bracket for mounting the door with the return air openings low (shown in option 1) or high (shown in Option 2) on the door. For increased sound reduction, it is recommended to install the door with the return air opening in the high position.

The door panel has a provision for filter installation on the door. This feature is only usable when the door is installed in the lower orientation (Option 1) and the unit filter has been removed.

The unit should not be operated with both the unit filter and the door filter installed.

FreshAire™ System Set-Up and Operation

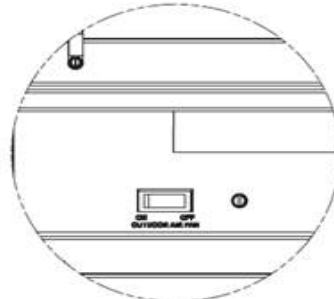
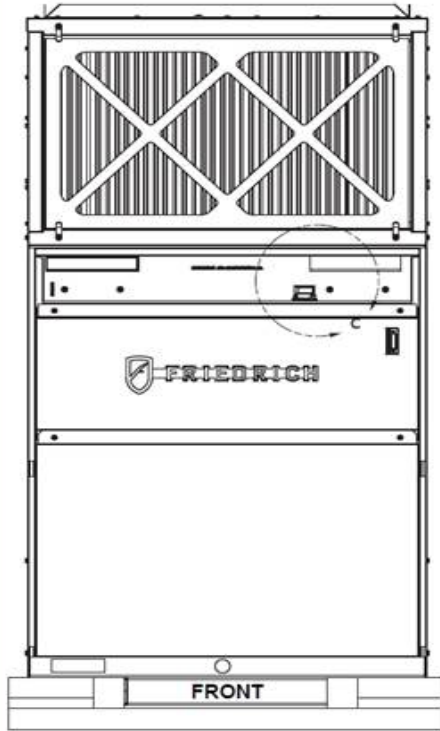

DETAIL C

If equipped with the FreshAire™ System, the unit will come with a FreshAire filter and blank-off plate.

Remove the blank-off plate prior to turning the unit on.

To remove the blank off plate, pull the attached tab shown in Detail A. The blank-off plate can be discarded or retained for future use.

To engage the FreshAire™ System, flip the switch into the On Position.

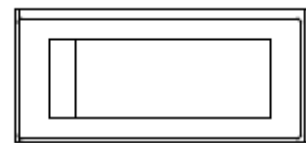

ON OFF
OUTDOOR AIR FAN

Electrical Wiring Diagram - VRP24 265V 7.5 & 10.0 kW

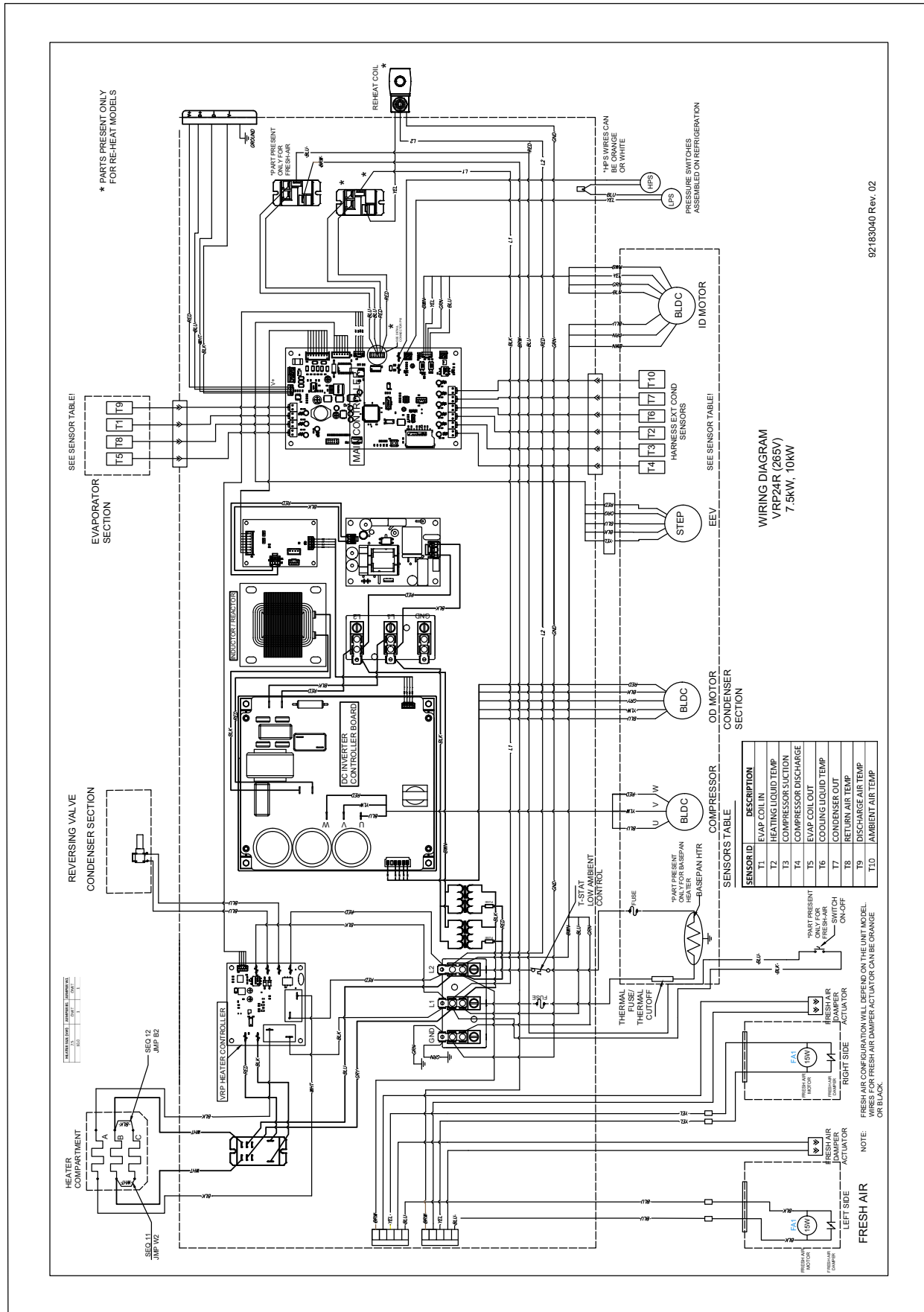

92183040 Rev. 02

Basepan Heater

Basepan Heat Thermostat

VRP model numbers that end with the 'L' character will come equipped with a basepan heater. The basepan heat engages and disengages automatically based on outdoor ambient and base-pan temperatures.

Final Installation Checklist

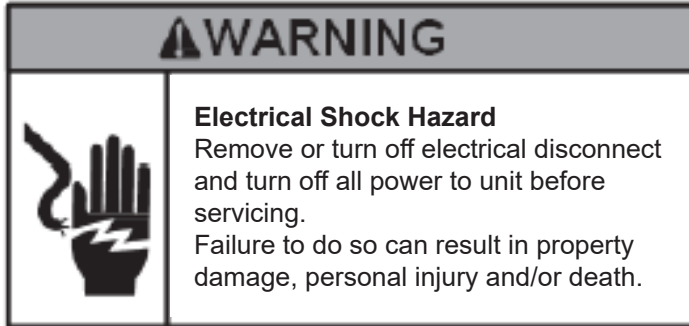

- Inspect and ensure that all components and accessories have been installed properly and that they have not been damaged during the installation process.
- Ensure that all installation instructions concerning clearances around the unit have been adhered to.
- Check to ensure that the unit air filter, indoor coil, and outdoor coil are free from any obstructions.
- Ensure that the circuit breaker(s) or fuse(s) and supply circuit wire size have been sized correctly.
- Check the condensate water drain(s) to ensure that they are adequate for the removal of condensate water and that they meet approval of the end user.
- Ensure that the entire installation is in compliance with all applicable national and local codes and ordinances having jurisdiction.
- **ENSURE THAT THE SUPPLY VOLTAGE TO THE UNIT IS WITHIN THE OPERATING RANGE**
- Secure all access panels (i.e. front cover and/or control box), apply power to the unit.
The unit commissioning should be done at this time to ensure unit function.

NOTE: Maintaining a log for recording the dates of maintenance and/or service is recommended, and should be suggested to the owner or operator of the equipment.

- Present the owner or operator of the equipment with the Installation & Operation Manual, all accessory installation instructions, and the name, address and telephone number of the Authorized Friedrich Warranty Service Company in the area for future reference if necessary.

Chassis Operation

Cooling Operation

The set point must be at least 3°F below room temperature to ensure compressor operation. In the cooling mode, when demand is present, the indoor blower and outdoor fan will operate. The compressor will vary operating speed to maintain desired set point.

Heat Pump Operation

The set point must be greater than 3°F but not greater than 6°F above room temperature to ensure compressor operation. In the heating mode, when demand is present, the indoor blower and outdoor fan will operate. The compressor will vary operating speed to maintain desired set point.

Electric Heat Operation

If the set-point is greater than 5°F - 15°F (depending on outdoor conditions) above room temperature, the heat pump operation will be terminated and the electric heater will be energized to satisfy the heating demand. If heat pump operation is not available due to defrost or error, the electric heater will be used to satisfy heating demand.

FreshAire™

The FreshAire™ System (optional) delivers outside air to the indoor space. The system has a fan that draws outdoor air into the system. The outdoor air enters the system through a filter and enters the indoor space in front of the indoor conditioning coil. The outdoor air mixes with the return air and is drawn through the indoor conditioning coil. The optional system can be configured to have either a single (F option) outdoor air fan and filter, or dual (D option) outdoor air fans and filters.

The FreshAire™ System uses a 6 x 6 x 1 filter (quantity of 1 for option F and 2 for option D). The filters are accessed through the front of the unit just below the main unit filter. Slide the filter straight out to remove and straight in to replace.

Service & Warranty

Servicing / Chassis Quick Change Outs

The chassis is designed for quick disconnect and change out. For minor electrical service, the Electrical Access Panel is easily removable once the screws are removed. For major electrical, refrigeration and fan service the chassis may be removed from utility closet.

⚠ WARNING	
	<p>Electrical Shock Hazard Remove or turn off electrical disconnect and turn off all power to unit before servicing. Failure to do so can result in property damage, personal injury and/or death.</p>

Routine Maintenance Performing Routine Maintenance

With proper maintenance and care, your system will operate economically and dependably. Maintenance can be accomplished easily by referring to the following directions. However, before performing any maintenance, see above stated WARNING.

⚠ CAUTION	
	<p>Cut/Sever Hazard Some edges may be sharp, use gloves or other hand protection when handling unit. Failure to do so can result in minor to moderate personal injury.</p>

Replace Air Filter

A dirty air filter reduces the efficiency of your VRP unit and allows lint and dirt to accumulate on the indoor-air coil. Lint and dirt on the indoor-air coil can damage your unit.

The air filter should be replaced as it becomes dirty.

To replace the chassis mounted return air filter:

1. Slide the holders away from the filter.
2. Remove the filter.
3. Install a new disposable filter.
4. The unit filter size is 14" x 24" x 1"

NOTE: DO NOT OPERATE YOUR SYSTEM WITHOUT A FILTER IN PLACE OR BLOCK THE FRONT OF THE UNIT RETURN AIR OPENING.

To Remove the Chassis from the Closet:

- A. Switch the wall controller off.
- B. Disconnect the power coming into the unit from the main breaker panel or the closet mounted disconnect.
- C. Disconnect the electrical connection.
- D. Disconnect the duct work.
- E. Slide the chassis out of the wall plenum.
- F. Slide and slightly lift the chassis out of the utility closet.

Inspect and Clean Indoor Air Coil

Eventually, minor amounts of lint and dirt may pass through the filter and collect on the indoor-air coil. These minor accumulations can be carefully vacuumed away with a brush attachment on a vacuum cleaner. Care must be taken to avoid bending the aluminum fins on the coil. Bent fins should be straightened using a special fin tool available from most HVAC supply depots.

Inspect Outdoor Air (OA) Intake and Exhaust

The unit's outdoor-air intake and outdoor-air exhaust paths must remain clear. Keep it free of all debris, snow, or ice. The OA intake should also be kept free of obstructions. Blocking the OA exhaust or OA intake opening will reduce the efficiency of your unit and could damage it.

Inspect and Clean Condensate Drain

The condensate drain must be routed to a suitable drainage area. Check the unit condensate drain periodically. Keep it free of anything that may block or impede the flow of condensate water. If there is any accumulation of foreign matter in the drain pipe, it should be removed and cleaned. The entire drain line must be protected from freezing.

Warranty

All warranty service work must be done by an authorized servicer. See Product Warranty, and consult your dealer or contractor for details.

Electronic Control Error Code Diagnostics and Test Mode

Error Code Diagnostics



The VRP electronic control continuously monitors the unit operation and will store error codes if certain conditions are witnessed. In some cases the unit may take action and shut the unit off until conditions are corrected.

To enter the error code menu, do a long press (3 seconds) of the Fan Mode and Fan Speed keys. When the menu opens an E will be displayed on the screen. Navigate through the diagnostics with the Up and Down keys.

The displayed number denotes the number of the active diagnostic test.

To exit, press the Enter key.

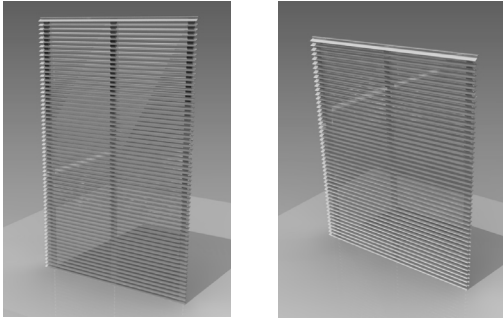
Accessories

ITEM	DESCRIPTION	CHECK LIST
VRPXWPA-8	Wall Plenum for VRP12 with VRPXALA for 4" to 8" thick wall	Require One of these Wall Plenums per unit
VRPXWPB-8	Wall Plenum for VRP24 with VRPXALB up for 4" to 8" thick wall (Can also be used with VRP 12)	
VRPXWPA-14	Wall Plenum for VRP12 with VRPXALA for 8" to 14" thick wall	
VRPXWPB-14	Wall Plenum for VRP24 with VRPXALB up for 8" to 14" thick wall (Can also be used with VRP 12)	
		
VRPXALA	Architectural louver (VRP12 only) (30° Blade angle)	Require One of these Louvers per unit
VRPXALB	Architectural louver (VRP24) (30° Blade angle) (Can also be used for VRP12)	
VRPXSCA	Architectural louver (VRP12 only) Custom Color - Special Order (30° Blade angle)	
VRPXSCB	Architectural louver (VRP24) Custom Color - Special Order (30° Blade angle) (Can also be used for VRP12)	
		
VRPXAP1	Louvered Access Panel (Left and Right Hinged)	Require One per unit
VRPXAPPR1	Hanging Perimeter Access Panel	
	<p style="text-align: center;">VRPXAP1</p> 	

Accessories

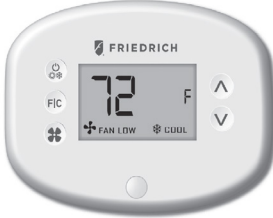
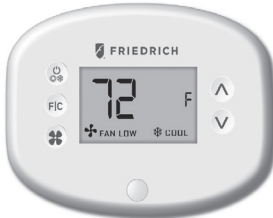
ITEM	DESCRIPTION	CHECK LIST
VRPXWCT	Wall Controller  VRPXWCT	Required one per unit
VRPXEMRT2	VRP Energy Management Wired Wall Controller with Occupancy Sensor	Require One of the Controllers per unit
VRPXEMWRT2	VRP Energy Management Wireless Wall Controller with Occupancy Sensor  VRPXEMWRT2	
EMOCT	Online Connection Kit – Optional with VRPXEMRT1/VRPXEMWRT1	Optional
EMRAF	Remote Access Fee – Optional with VRPXEMRT1/VRPXEMWRT1	Optional

Diagnostic Error Codes

Code	Description
3	Return air thermistor open/shorted
4	Indoor coil (cool inlet) thermistor open/shorted
5	Outdoor coil (heat inlet) thermistor open/shorted
6	Discharge air thermistor open/shorted
7	Outdoor ambient thermistor open/shorted
8	Indoor coil (heat cond.) thermistor open/shorted
9	Compressor discharge thermistor open/shorted
10	Compressor suction thermistor open/shorted
11	Liquid cool thermistor open/shorted
12	Liquid heat thermistor open/shorted
13	Humidity sensor open/shorted
14	Pressure limit switch open
19	Outdoor coil temperature above 175F
20	Indoor coil frozen
21	Unit cycles more than five (5) times an hour
23	Room freeze protection
24	Discharge air temperature above 185F
26	Ambient temperature beyond operating limits
27	Minimum configuration not met
31	Outdoor fan over current
32	Compressor over current
34	Unit not provisioned
35	DC bus over voltage
36	DC bus under voltage
39	Low blower speed
40	Wall controller disconnected
41	EEV fault
43	MCS communication failure
47	Compressor I2T fault
46	Indoor Coil above 175F
49	Outdoor fan I2T fault
51	Incorrect MCS firmware
52	PFC over voltage
53	AC line under voltage
54	AC line over voltage



FRIEDRICH

Friedrich Air Conditioning Co.

10001 Reunion Place, San Antonio, TX 78216

800.541.6645

www.friedrich.com

VRP Variable Refrigerant
Packaged Heat Pump

LIMITED WARRANTY

1. A) ONE YEAR PARTS WARRANTY - FRIEDRICH AIR CONDITIONING CO. (FRIEDRICH) warrants to the original end-user of this product that should it prove defective due to improper workmanship and/or material under normal use for a period of one year from the date of installation, FRIEDRICH will repair or replace, at its option, any defective part without charge for the part. Replacement parts are warranted for the remainder of the original warranty period.

B) THIS WARRANTY DOES NOT INCLUDE LABOR or other cost incurred for servicing, repairing, removing, installing, shipping, or handling of either defective or replacement parts, or complete unit. Such cost may be covered by a separate warranty provided by the installing contractor.

C) SECOND THROUGH FIFTH YEAR (Sixty (60) months from the date of installation). On the sealed REFRIGERATION SYSTEM. Any part of the sealed refrigeration system that is defective in material or workmanship will be repaired or replaced free of charge (excluding freight charges) by our authorized service center during normal working hours. The sealed refrigeration system consists of the compressor, metering device, evaporator, condenser, reversing valve, check valve, and the interconnecting tubing. **LABOR IS NOT INCLUDED FOR INSTALLING REPLACEMENT PARTS.**

These warranties apply only while the unit remains at the original site and only to units installed inside the continental United States, Alaska, Hawaii, Puerto Rico, and Canada. The warranty applies only if the unit is installed and operated in accordance with the printed instructions and in compliance with applicable local installation and building codes and good trade practices. For international warranty information, contact the Friedrich Air Conditioning Company - International Division.

D) NOTICE: To obtain service and/or warranty parts replacement, you must notify an authorized FRIEDRICH Air Conditioning Co. distributor, dealer, or contractor of any defect within the applicable warranty period.

2. Any defective part to be replaced must be made available to FRIEDRICH in exchange for the replacement part. You must present proof of the original date of installation of the product in order to establish the effective date of the warranty. Otherwise, the effective date will be deemed to be the date of purchase plus thirty days. The return of the owner registration card is not a condition of warranty coverage. However, please detach and return it so that we can contact you should a question of safety arise which could affect you.

3. TO OBTAIN WARRANTY SERVICE, please contact your authorized FRIEDRICH distributor, dealer, or the contractor who installed the equipment. If your dealer or contractor needs assistance, the authorized FRIEDRICH distributor is available for consultation, and FRIEDRICH supports the efforts of the distributor.

4. This limited warranty applies only to units remaining at the site of the original installation (except for mobile home installations) and only to units installed within the continental United States, Alaska, Hawaii, and Canada. This limited warranty applies only if the unit is installed and operated in accordance with FRIEDRICH instructions and in compliance with applicable local installation and building codes and good trade practices.

5. THIS WARRANTY DOES NOT COVER damages caused by: (a) accident, abuse, negligence, or misuse; (b) operating the product in a corrosive atmosphere containing chlorine, fluorine or any other damaging chemicals; (c) modification, alteration, poor service practices; (d) improper matching or application of the product or components; (e) failure to provide proper maintenance and service to the product according to manufacturer's instructions; (f) installation or operating of the product in a manner contrary to the instructions of the manufacturer; (g) lightning, fluctuations in electrical power or other Acts of God; (h) operation of the unit during construction. This LIMITED WARRANTY also excludes all cost of installation, disconnection or dismantling the product, parts used in connection with normal maintenance such as air filters or belts and owner-required maintenance. Consult the instructions enclosed with the product for information regarding recommended maintenance.

6. No one is authorized to change this LIMITED WARRANTY in any respect, or to create any other obligation or liability in connection with this product.

7. YOUR ONLY REMEDIES ARE PROVIDED IN THIS LIMITED WARRANTY. ANY EXPRESS WARRANTY NOT PROVIDED HEREIN, AND ANY REMEDY WHICH, BUT FOR THIS PROVISION, MIGHT ARISE BY IMPLICATION OR OPERATION OF LAW, IS HEREBY EXCLUDED AND DISCLAIMED. THE IMPLIED WARRANTIES OF MERCHANTABILITY AND OF FITNESS FOR ANY PARTICULAR PURPOSE ARE EXPRESSLY LIMITED TO A TERM OF ONE YEAR FROM THE DATE OF ORIGINAL INSTALLATION. UNDER NO CIRCUMSTANCES SHALL FRIEDRICH BE LIABLE TO THE OWNER OR ANY OTHER PERSON FOR ANY INCIDENTAL, SPECIAL OR CONSEQUENTIAL DAMAGES IN CONNECTION WITH THIS PRODUCT, WHETHER ARISING OUT OF BREACH OF WARRANTY, BREACH OF CONTRACT OR OTHERWISE.

8. Some states do not allow limitations on how long an implied warranty lasts and/or do not allow the exclusion or limitation of incidental, special or consequential damages, so the above limitations or exclusions may not apply to you.

9. This warranty gives you specific legal rights, and you may have other rights which vary from state to state and province to province.

10. This warranty is valid in the U.S.A. and Canada and is not transferable.

(11-2019)

THIS PAGE INTENTIONALLY LEFT BLANK.

VRP[®]

Variable Refrigerant
Packaged Heat Pump

Innovative | Intelligent | Inverter

