

FACTORY PARTS CATALOG FREEZER

MULTIFLEX\UNIVERSAL

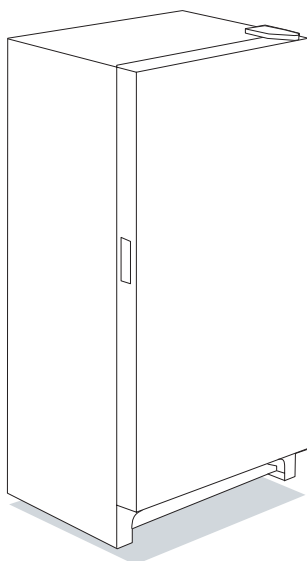

PRODUCT NO.	BASE MODEL NO.	SERIES	COLOR	VOLTS
CFU09M2HW0	CFU09M2HW	134A	white	115
CFU12M2HW0	CFU12M2H	134A	white	115
CFU14M2HW0	CFU14M4H	134A	white	115

MARKET

North America

WIRING DIAGRAM - # 216576600
OWNER'S GUIDE - # 216602400
SERVICE DATA SHEET - # 216576600

FRIGIDAIRE
HOME PRODUCTS

101 Masters Blvd.
 Anderson, SC 29624

Publication No.

5995320073

990324

-EN/SERVICE /GS
365

FREEZER

Model No.

CFU09M2HW0
CFU12M2HW0
CFU14M2HW0

©1999White Consolidated Industries, Inc.
 All rights reserved

DOOR

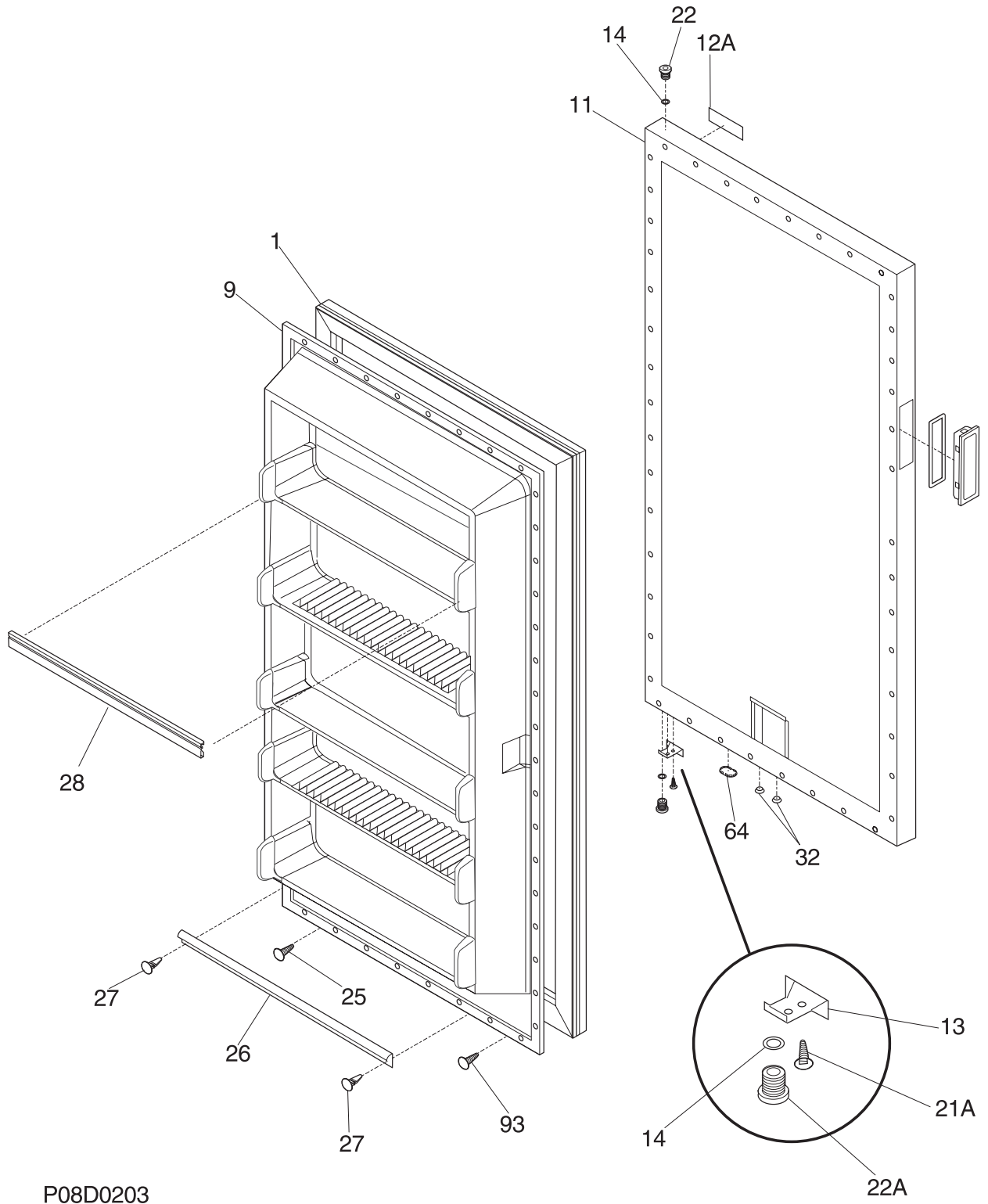

P08D0203

DOOR

A = CFU09M2HW (CFU09M2HW0)
B = CFU12M2HW (CFU12M2HW0)
C = CFU14M2HW (CFU14M2HW0)

POS. NO	PART NO		DESCRIPTION
1	216522300	A - -	Gasket-door
1	216522303	- B -	Gasket-door,white
1	216522306	- - C	Gasket-door,white
9	216527205	A - -	Panel-inner door,frzr
9	216527402	- B -	Panel-inner door,white ,frzr
9	216527612	- - C	Panel-inner door,white ,frzr
11	216564201	A - -	Panel-door,white
11	216565401	- B -	Panel-outer door,white
11	216557801	- - C	Panel-outer door,white
12A	216373000	A B C	Frame-nameplate
13	08016354	A B C	Door Stop
14	5303313518	A B C	Washer,sealing
21A	08005520	A B C	Screw-door stop mtg,flat hd metric , 4.0 x 0.7-19.7
22	216443600	A B C	Bearing
22A	216503200	A B C	Bearing-hinge,btm
25	216022800	A B C	Screw,washer head ,8-18 X 1/2
26	216524400	A - -	Gasket-secondary
26	216524300	- B C	Gasket,secondary
27	5303212828	A B C	Clip,panel
28	216523500	A - -	Rack-shelf,wide ,white
28	216523300	- B C	Rack-shelf,wide
32	5309950074	A B C	Valve-breather
64	216403700	A B C	Plug-button,base door
93	5303161215	A B C	Screw

CABINET

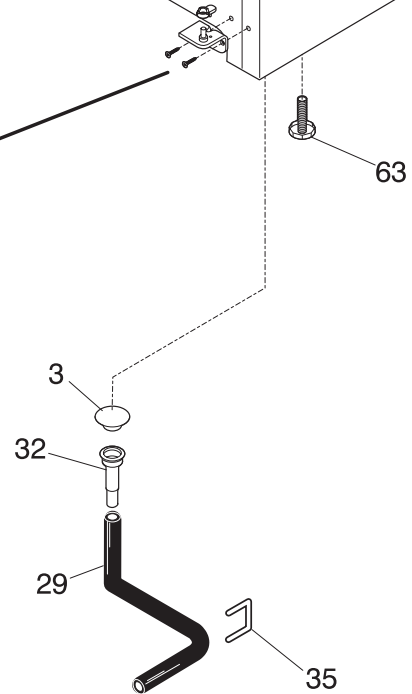
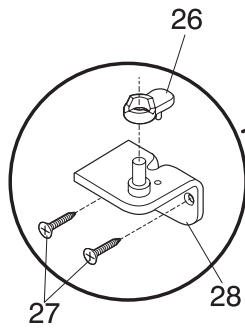
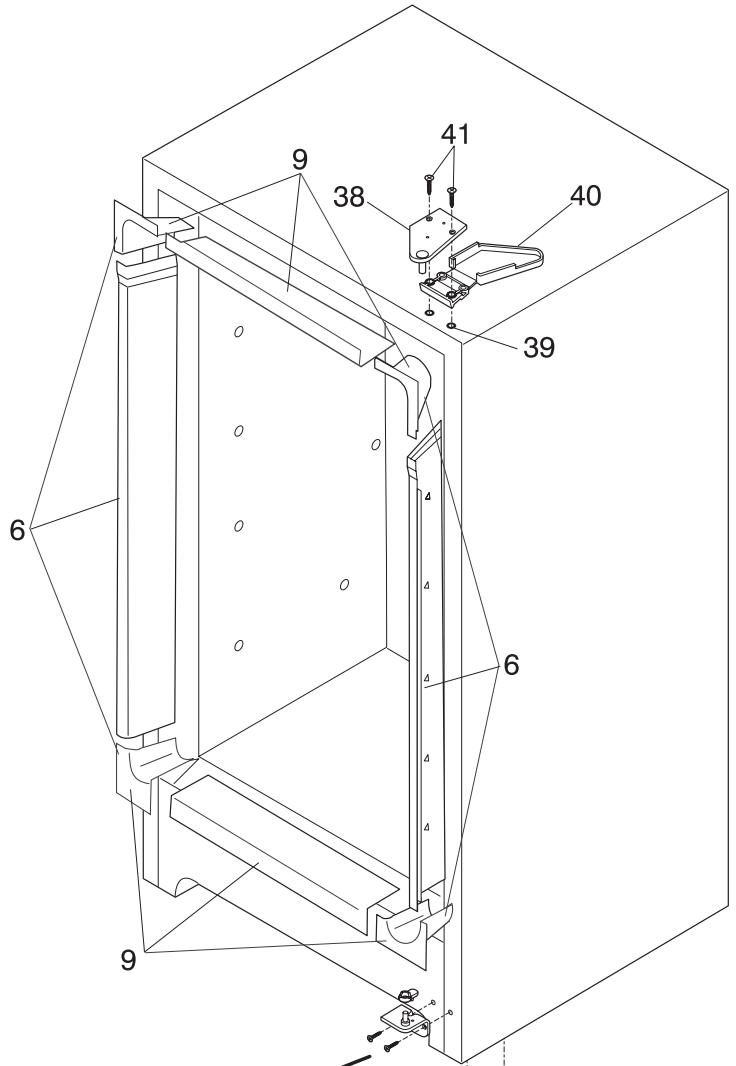
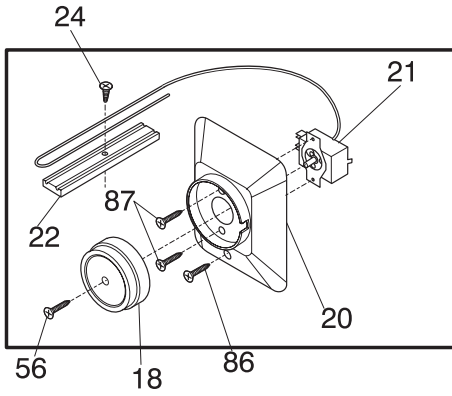

CABINET

A = CFU09M2HW (CFU09M2HW0)
B = CFU12M2HW (CFU12M2HW0)
C = CFU14M2HW (CFU14M2HW0)

POS. NO	PART NO		DESCRIPTION
3	216502600	A B C	Plug-drain,exterior
6	216604200	A - -	Breaker Kit w/corners
6	216604400	- B -	Breaker Kit w/corners
6	216604300	- - C	Breaker Kit w/corners
9	216603500	A - -	Breaker,top
9	216603400	- B C	Breaker Kit w/corners,28" ,top or bottom
18	216591802	A B C	Knob,temp control
20	5303288184	A B C	Cover-control housing
21	216620100	A B C	Control-temperature
22	08037931	A B C	Clamp,cap tube ,cold control
24	5300052943	A B C	Screw-clamp,truss hd cr ,control
26	216503300	A B C	Ramp,closer ,door
27	5303205738	A B C	Screw-hinge,cr ,1/4-20 x 1.000 ,btm
28	216247400	A B C	Hinge-bottom
29	216313500	A B C	Hose-drain
32	5308005500	A B C	Drain
35	216273000	A B C	Clip,drain hose
38	5303925086	A B C	Hinge-upper
39	5303294372	A B C	Nut-insert,hinge
40	5303212912	A B C	Cover-hinge
41	5303212937	A B C	Screw-top hinge
56	09950853	A B C	Screw-control knob,phillips ,4-40 x 3/8
63	216396900	A B C	Foot-adjustable
86	216036600	A B C	Screw,rwhd (gx-ca) ,8-32 x 1/2
87	08037849	A B C	Screw
*	09948773	A B C	Insulation,drain tube
*	5303305324	A B C	Paint,touch-up ,white

SYSTEM

A = CFU09M2HW (CFU09M2HW0)
B = CFU12M2HW (CFU12M2HW0)
C = CFU14M2HW (CFU14M2HW0)

POS. NO	PART NO		DESCRIPTION
1 #	5303304537	A - -	Condenser
1 #	5300123788	- B C	Condenser
3	216097700	A - -	Trim-shelf,evaporator
3	216097800	- B C	Trim-shelf,evaporator
4	216634500	A B C	Drier-filter
5 #	216609200	A B C	Wiring-diagram,main
6	3091418	A B C	Support-shelf,front LH
7	08037928	A B C	Support-shelf,front RH
11	216474600	A B C	Support-rear shelf
12	216225700	A B C	Grommet-spacer
13	216138900	A B C	Screw,hex sems ,8-18AB x 1.00 ,evap
15A	216404900	A B C	Heat Exchanger
27	216498900	A B C	Grommet,compressor
29	216510900	A	Compressor, w/elec
29 #	5304409881	- B -	Compressor,Service
29 #	53039218003	- - C	Compressor,Service
30	216511200	A - -	Starter-PTC
30	216596800	- B -	Starter
30	216596700	- - C	Starter,factory instal
31	216100113	A - -	Overload Protector
31	216100117	- B -	Overload Protector
31	216100116	- - C	Overload Protector,factory instal
34	5306594529	A B C	Sleeve-compressor
35	5303272328	A B C	Screw,Ind hex sems ,1/4-28 unfx ,compr.
36 #	216069300	A - -	Grid-top evaporator
36 #	216069700	- B -	Grid-top evaporator
36 #	216070100	- - C	Grid-top evaporator
37 #	216069400	A - -	Shelf-top evaporator
37 #	216069800	- B -	Shelf-top evaporator
37 #	216070200	- - C	Shelf-top evaporator
38 #	216069500	A - -	Shelf-middle evaporator
38 #	216069900	- B -	Shelf-middle evaporator
38 #	216070300	- - C	Shelf-middle evaporator
40 #	216069600	A - -	Shelf-bottom evaporator
40 #	216070000	- B -	Shelf-bottom evaporator
40 #	216070400	- - C	Shelf-bottom evaporator
43	09950610	- B C	Clip,cord
43A	216629700	A B C	Clip-harness
53	216347800	A B C	Cover,compressor
86	216036600	A B C	Screw,rwhd (gx-ca) ,8-32 x 1/2
*	08016777	A - -	Clamp,pwr cord assy