



Breathe easy.

Demand Control Autostart System

MODEL "DCA"

Technical Manual

GAYLORD INDUSTRIES

10900 SW Avery Street – Tualatin, Oregon 97062 USA

Email: info@gaylordventilation.com Toll Free 800-547-9696 – Fax 503-692-6048

www.gaylordventilation.com

All rights reserved. No part of this book may be reproduced, stored in a retrieval system, or transmitted in any form by an electronic, mechanical, photocopying, recording means or otherwise without prior written permission of Gaylord Industries.

©Copyright 2015, Gaylord Industries

The manufacturer reserves the right to modify the materials and specifications resulting from a continuing program of product improvement or the availability of new materials

Table of Contents

Chapter 1 – Introduction

About the Manual	1-1
List of Abbreviations and Acronyms	1-1
DCV System Overview	1-2
Code Compliance	1-2

Chapter 2 – System Components

Overview	2-1
Resistance Temperature Detectors (RTDs).....	2-2
The DCA Control Box.....	2-2
The Control Board	2-3

Chapter 3 – Servicing the System

DCA Factory Settings	3-1
Accessing the Active Mode	3-1
Accessing the Program Mode	3-1
Adjusting the Temperature Setpoint	3-2
Adjusting the Shutdown Timer	3-2
DCA RTD Calibration	3-9

Chapter 4 – Wiring

Primary Control Box Wiring	4-1
Secondary Control Box Wiring	4-1

Chapter 5 –Replacement Parts

DCA Replacement Parts	5-1
-----------------------------	-----

Limited Warranty	Inside Back Cover
------------------------	-------------------

About this Manual

The purpose of this manual is to provide guidance for pre-installation assessment, installation, programming, and commissioning information for the Gaylord Demand Control Autostart System Model DCA. The manual also includes detailed information on adjustments to the system and a complete list of replacement parts.

The manual is divided into chapters for easy reference to a particular subject. The pages in the chapters are numbered with the Chapter number, then a dash, and then the Page number. So for example pages in Chapter 2 are numbered 2-1, 2-2, 2-3 etc. Figures and Tables are numbered in a similar manner. For example Figure 5-3-2 is on Page 5-3 and is the second figure. Please keep your manual in a convenient location for so it can be accessed easily.

If you have any questions or concerns with the installation of the Gaylord Demand Control Ventilation System, please contact Gaylord Industries.

Web: www.gaylordventilation.com

E-Mail: info@gaylordventilation.com

Main Phone: 503-691-2010

Toll Free: 800-547-9696

This manual and other Gaylord product manuals may be downloaded from the Gaylord website: www.gaylordventilation.com or be obtained by calling Gaylord Industries.

List of Abbreviations and Acronyms

BMS	Building Management System
CFM	Cubic Feet per Minute (Air Volume)
CSA	Certified Service Agency
DCA	Demand Control Autostart
DCKV	Demand Control Kitchen Ventilation
EF	Exhaust Fan
FP	Fire Protection (System)
FPM	Feet Per Minute (Air Speed- Velocity)
HVAC	Heating Ventilating Air Conditioning (unit)
IMC	International Mechanical Code
MUA	Makeup Air
NFPA	National Fire Protection Association
RTD	Resistance Temperature Detector
WG	Water Gauge

DCA System Overview

The Gaylord DCA system automatically starts and stops the kitchen exhaust based on the activity of the cooking equipment. Heat generated by the cooking equipment is detected by hood mounted sensors. Whenever the temperature setpoint is exceeded the fan will start. When the temperature drops below the setpoint for 60 minutes (adj.), the fan will stop (note: external switching can override the fan on). The Gaylord DCA system is designed to meet the requirements of IMC 2012 Section 507.2.1.1.

Each hood has a primary controller to interpret the sensor feedback and start/stop the fan. If the hood has multiple sections then each additional section will have a secondary controller to read the sensors and communicate data back to the primary controller.

The Gaylord DCA system may also be converted to a Demand Control Kitchen Ventilation (DCKV) system. The control boards have additional parameters that are not used for DCA, but function for DCKV. Aftermarket conversion services are available through a Gaylord DCV-Retrofit Certified Service Agent (CSA). CSAs can be found on the Gaylord website at http://gaylordventilation.com/Service_Agencies/.

Code Compliance

The DCA Series control is a recognized component to a UL 710 listed commercial kitchen hood, complying with IMC 507.2.1.1 and the latest edition of NFPA 96. Additionally they are listed to ULC s646, UL 873, CSA C22.2#24, and UL 508. Contact Gaylord Industries for additional information.

System Components

As illustrated in Figure 2-1-1 below the Gaylord DCA system is made up of canopy mounted RTDs and a control box for each hood section. The primary control box provides 120V switching for the fan, while the secondary control box communicates information about its section to the primary control box. Secondary control boxes are only used on multi-section hoods. One primary control box can receive information from up to five secondary control boxes. The quantity and location of the RTDs are determined by the type of hood and the length. Each hood section can have from one to four RTDs mounted in the canopy.

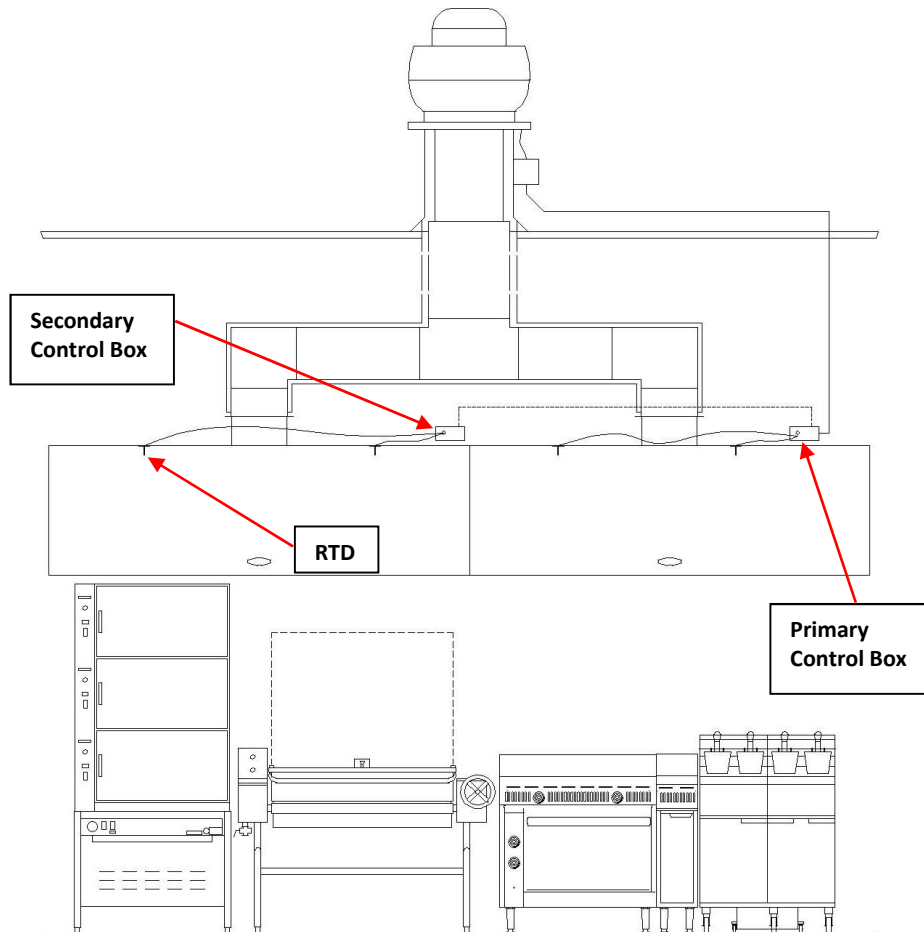

Figure 2-1-1: Components of Gaylord DCA System

Resistance Temperature Detectors (RTD)

Resistance Temperature Detectors (RTDs) are a high quality and very accurate temperature sensor (refer to Figures 2-2-1 and 2-2-2). The Gaylord RTDs are Listed for mounting in commercial kitchen exhaust hoods. Each hood section has one or more RTDs mounted in the canopy. The RTDs are connected by 12-volt cable to the DCA control box mounted on the top of the hood.

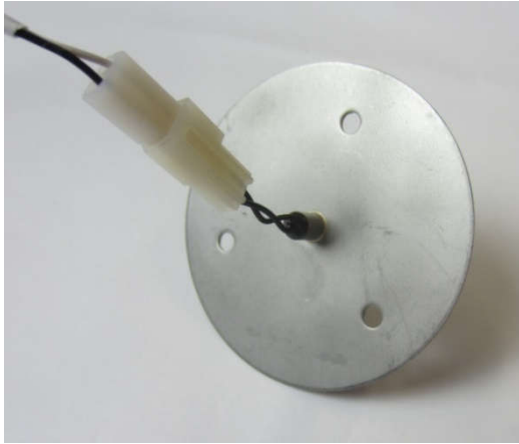

Figure 2-2-1: RTD back



Figure 2-2-2: RTD front

The DCA Control Box

The DCA control box contains the control board and is mounted on top of each section of hood. If the box contains a primary control board it will also have a connection for 120V power, a relay to start the fan, and a 12VDC power supply. The standard location is on the right front corner, though it may also be located in other locations on top of the hood due to space constraints. Access to the box is through a panel (refer to Figure 2-2-3) on the inside of the canopy.

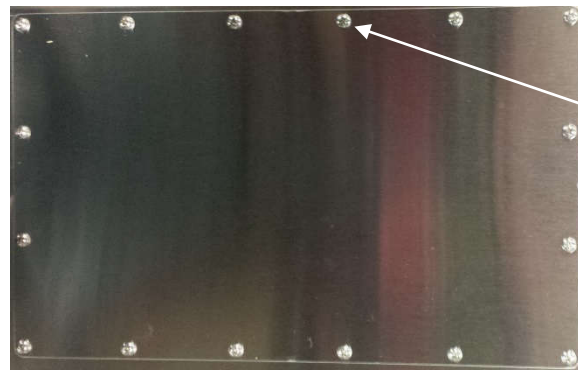

**8-32 x 3/8 SS Pan Head.
Use manual screwdriver
or low-speed, powered
driver to prevent galling.**

Figure 2-2-3: Control Box Access Panel

The Control Board

The brain of the system is the control board. Each hood will have at least one primary control board. Each additional section of a multi-section hood will have a secondary control board. The secondary control board reads RTDs in its section, and then transmits that information to the primary board for that hood. The DCA control board is shown in Figure 2-3-1 below with the arrows pointing to the interface elements.

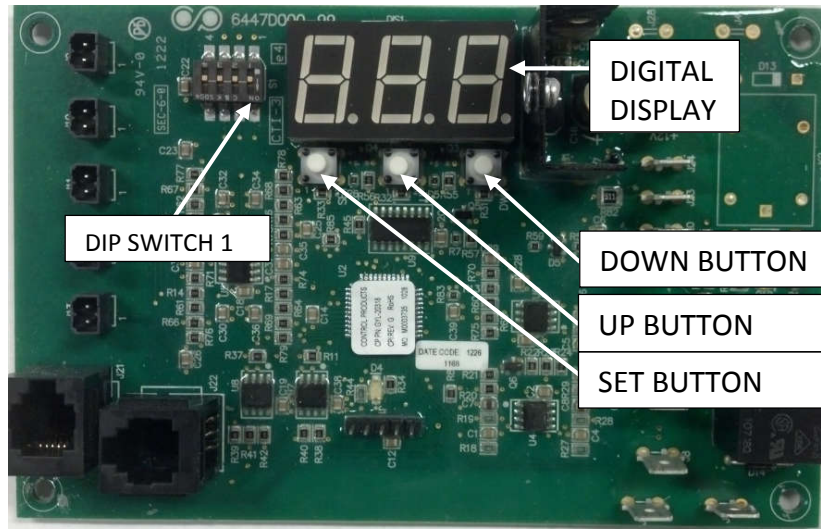

Figure 2-3-1: DCA Control Board Interface

The DIP switch closest to the digital display is DIP switch 1. This is used to switch between Active and Program mode. In order for the system to function properly, the switch must be in the Active or up position. With the switch in the down position the system is in Program mode and the display will show “Pro”. While in Program mode the system will not change state (e.g., if the fan is running, it will stay running). Program mode is used to set the system parameters.

This Page Intentionally Left Blank

Servicing the system

DCA Factory Settings

DCA control boards are factory set to the parameters listed in Tables 3-1-1 and 3-2-1.

Table 3-1-1: Primary Board Parameters

Parameter	Setting
Con	on
AbS	PrE
Set	75
Sdt	60
tL	15

Table 3-1-2: Secondary Board Parameters

Parameter	Setting
Con	oFF
tL	15

There are many other parameters on the board, however only the factory set parameters are used for DCA. The additional parameters are for use in the DCKV aftermarket conversion. Changing the parameters is covered in the following sections.

Accessing the Active Mode

The Active mode is the normal state for operation of the DCA system. While in Active mode the data displayed is read-only. The interface consists of DIP switch 1, the Digital Display, and the Set, Up, and Down Buttons. The display is dark until the Set, Up, and Down buttons are simultaneously pressed for about 3 seconds. Once the display is lit the buttons can be pressed individually to view data. Initially a datum name will be displayed such as t0. To view the value of the datum, press the Set button and a number will be displayed. Pressing the Set button again, will return to the datum name and allow navigation to other data. Table 3-1-3 lists the data available that are relevant to the DCA system.

Table 3-1-3: DCA Active mode menu

DCA Active mode Data	
t0	Temperature at RTD-1
t1	Temperature at RTD-2
t2	Temperature at RTD-3
t3	Temperature at RTD-4
Ft	Shutdown timer

Accessing the Program Mode

The Program mode is used to set the parameters of the control board which define its operation. To enter the Program mode move DIP switch 1 down. Whenever the board is in Program mode the display will be lit and the board will remain in the same control state that it was prior to entering Program mode. The initial display will show "Pro". The next parameter can be displayed by pressing the Set button. First the name is displayed, and then another press of the Set button will display the value for the named parameter. When the value is displayed the Up and Down buttons can be used to change the value. Pressing the Set button retains the value and displays the next parameter name. Table 3-2-1 on the following page lists the parameters used by the DCA system.

Table 3-2-1: DCA Program mode menu

DCA Program mode parameters			
Name	Description	Values	Description
Con	Controller Setting	on	Primary controller
		oFF	Secondary controller
AbS	Ambient Temperature Source	Sen	Reads ambient temperature on control board terminal J9 (setting not used)
		PrE	Ambient temperature is preset
Set	Sets the ambient temperature	75	Factory set at 75
Sdt	Shut down time	60	Factory set at 60
tL	Temperature above ambient to start fan	15	Factory set at 15
CAL	Press Up and Down buttons simultaneously to enter Calibration Menu	ALL	Calibrates all RTDs at once
		S_0	Calibrates RTD-1 only
		S_1	Calibrates RTD-2 only
		S_2	Calibrates RTD-3 only
ALL	Calibrates all RTDs at once	S_3	Calibrates RTD-4 only
		80	Software default; change to actual measured value

Adjusting the Temperature Setpoint

The system is factory set to activate the fan when 90°F is detected in the canopy of any hood. This is a combination of two parameters: the ambient temperature setting and “tL”. The default value of the ambient temperature setting is 75°F – there is no need to adjust this setting. The default value of “tL” at each hood section is 15°F. To adjust the temperature setpoint either raise or lower “tL”:

1. Open the hood control box.
2. Move DIP switch 1 to programming mode.
3. Press the Set button repeatedly until “tL” is displayed.
4. Press the Set button one more time and a number is displayed.
5. Either press the up or down button repeatedly to change “tL” to the desired value.
6. Press the set button once.
7. Move DIP switch 1 to active mode.

Adjusting the Shutdown Time

The DCA system is factory set to stop the fan when the temperature drops below the temperature setpoint for 60 minutes. The shutdown time is adjustable from 1 to 120 minutes. To adjust the shutdown time:

1. Open the hood control box for the primary board.
2. Move DIP switch 1 to programming mode.
3. Press the Set button repeatedly until “Sdt” is displayed.
4. Press the Set button one more time and a number is displayed.
5. Either press the up or down button repeatedly to change “Sdt” to the desired value.
6. Press the set button once.
7. Move DIP switch 1 to active mode.

DCA RTD Calibration

Calibrating the RTDs is a necessary activity to ensure that the DCA system operates correctly. RTD stands for Resistance Temperature Detector. As the temperature changes at the RTD, so does the resistance that the control board reads on the circuit. The control board is pre-programmed to correlate the resistance to a specific temperature. However, because the resistance can vary based on the circuit characteristics (e.g., length of wire), it is necessary to tell the control board one temperature value while it reads a resistance – this is calibration. Once the RTD is calibrated, the control board will be able to determine the correct temperature for the resistance it reads in the circuit.

All of the RTDs mounted in the canopy of a hood have been factory calibrated. However, if an RTD is ever replaced, then it should be calibrated after installation. The calibration procedure is as follows:

1. Move DIP switch 1 to the Program position. Pro appears on the digital display
2. Press the Set button repeatedly until CAL appears on the digital display.
3. Simultaneously press the Up and Down buttons. ALL appears on the digital display.
4. Press the Up (or Down) button until the proper code appears (see Table 3-3-1).

Table 3-3-1: RTD Correlation Table

RTD	Board Terminal	Temperature Display	RTD Calibration
1	J9	t0	S_0
2	J10	t1	S_1
3	J11	t2	S_2
4	J12	t3	S_3

5. Press the Set button. A default number appears on the digital display.
6. Use a handheld temperature sensor to measure the temperature at the tip of an RTD mounted in the canopy.
7. Press the Up or Down button repeatedly until the measured value appears.
8. Press the Set button.
9. Move DIP switch 1 to the Active position.
10. Check the temperature value to verify calibration was successful.

This Page Intentionally Left Blank

Wiring Diagrams

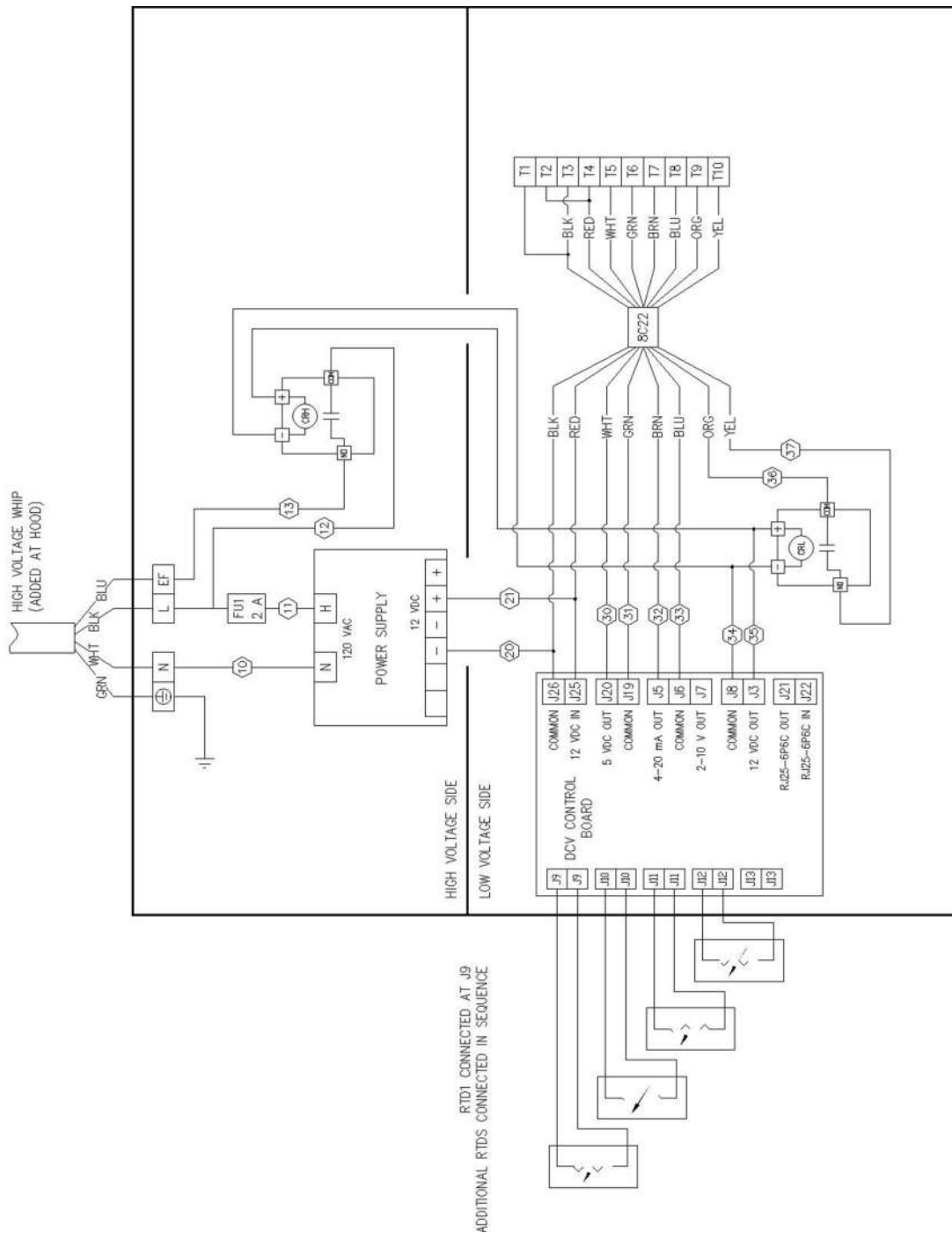

Figure 4-1-1: Primary Control Box Wiring Diagram

Table 4-2-1: Primary Termination Schedule

-- SUPPLY VOLTAGE -- 120 VAC, 60Hz. 2 AMPS MAXIMUM - CONNECTED LOAD		
TRM	TERMINATION SCHEDULE	TYPE
L	MAIN POWER CONNECTION : HOT	120VAC
N	MAIN POWER CONNECTION : NEUTRAL	0 V
EF	AUTOSTART FAN	120VAC
J3	RELAY OUTPUT (+12 VDC COIL)	VARIES
J5	FREQUENCY SETTING SIGNAL: 4-20 mA	VARIES
J6	FREQUENCY SETTING COMMON	COM
J7	FREQUENCY SETTING VOLTAGE : 2-10 VDC	VARIES
J8	RELAY COMMON	COM
J9	RTD INPUT	VARIES
J10	RTD INPUT	VARIES
J11	RTD INPUT	VARIES
J12	RTD INPUT	VARIES
J19	OVERRIDE COMMON (100% BUTTON)	0VDC
J20	OVERRIDE (100% BUTTON)	5VDC
J21	(RS232, 6P6C) COMMUNICATION	MOD BUS
J22	(RS232, 6P6C) COMMUNICATION	MOD BUS
J25	BOARD POWER SUPPLY	12 VDC
J26	BOARD POWER SUPPLY COMMON	COM
T1	12 VDC POWER COMMON	COM
T2	12 VDC POWER	12 VDC
T3	12 VDC POWER COMMON	COM
T4	12 VDC POWER	12 VDC
T5	MAX AIRFLOW	5 VDC
T6	MAX AIRFLOW COMMON	COM
T7	EF SPEED SIGNAL 4-20 mA	VARIES
T8	EF SPEED SIGNAL COMMON	0 VDC
T9	LOW VOLTAGE RUN SIGNAL	+24V
T10	LOW VOLTAGE RUN SIGNAL COMMON	0 VDC

Table 4-2-2: Primary Wiring Schedule

TERMINAL			WIRE		
LOCATION	TAG	TYPE	NUMBER	COLOR	GAUGE
TERMINAL BLOCK	N	SCREW	10	WHITE	16
POWER SUPPLY	N	MOLEX	10	WHITE	16
POWER SUPPLY	H	MOLEX	11	BLACK	16
FUSE BLOCK	FU1	SCREW	11	BLACK	16
TERMINAL BLOCK	L	SCREW	12	BLACK	16
FUSE BLOCK	FU1	SCREW	12	BLACK	16
RELAY CRH	COM	TAB	12	BLACK	16
TERMINAL BLOCK	EF	SCREW	13	BLACK	16
RELAY CRH	NO	TAB	13	BLACK	16
POWER SUPPLY	-	MOLEX	20	GRAY	18
CONTROL BOARD	J26	TAB	20	GRAY	18
CONTROL BOARD	J26	TAB	20	BLACK	8C22
TERMINAL STRIP	T3	SCREW	20	BLACK	8C22
TERMINAL STRIP	T3	SCREW	20	GRAY	18
TERMINAL STRIP	T1	SCREW	20	GRAY	18
POWER SUPPLY	+	MOLEX	21	PURPLE	18
CONTROL BOARD	J25	TAB	21	PURPLE	18
CONTROL BOARD	J25	TAB	21	RED	8C22
TERMINAL STRIP	T4	SCREW	21	RED	8C22
TERMINAL STRIP	T4	SCREW	21	PURPLE	18
TERMINAL STRIP	T2	SCREW	21	PURPLE	18
CONTROL BOARD	J20	TAB	30	WHITE	8C22
TERMINAL STRIP	T5	SCREW	30	WHITE	8C22
CONTROL BOARD	J19	TAB	31	GREEN	8C22
TERMINAL STRIP	T6	SCREW	31	GREEN	8C22
CONTROL BOARD	J5	TAB	32	BROWN	8C22
TERMINAL STRIP	T7	SCREW	32	BROWN	8C22
CONTROL BOARD	J6	TAB	33	BLUE	8C22
TERMINAL STRIP	T8	SCREW	33	BLUE	8C22
CONTROL BOARD	J8	TAB	34	GRAY	18
RELAY CRL	+	TAB	34	GRAY	18
RELAY CRH	+	TAB	34	GRAY	18
CONTROL BOARD	J3	TAB	35	PURPLE	18
RELAY CRL	-	TAB	35	PURPLE	18
RELAY CRH	-	TAB	35	PURPLE	18
RELAY CRL	COM	TAB	36	BLUE	18
TERMINAL STRIP	T9	SCREW	36	ORANGE	8C22
RELAY CRL	NO	TAB	37	YELLOW	18
TERMINAL STRIP	T10	SCREW	37	YELLOW	8C22

-- SUPPLY VOLTAGE --
12 VDC, 60Hz.

TRM	TERMINATION SCHEDULE	TYPE
J9	RTD INPUT	VARIABLE
J10	RTD INPUT	VARIABLE
J11	RTD INPUT	VARIABLE
J21	(RS232, 6P6C) COMMUNICATION	MOD BUS
J22	(RS232, 6P6C) COMMUNICATION	MOD BUS
J25	BOARD POWER SUPPLY	12 VDC
J26	BOARD POWER SUPPLY COMMON	COM
T1	12 VDC POWER COMMON	COM
T2	12 VDC POWER	12 VDC
T3	12 VDC POWER COMMON	COM
T4	12 VDC POWER	12 VDC

TERMINAL			WIRE		
LOCATION	TAG	TYPE	NUMBER	COLOR	GAUGE
CONTROL BOARD	J26	TAB	20	GRAY	18
TERMINAL STRIP	T3	SCREW	20	GRAY	18
TERMINAL STRIP	T3	SCREW	20	GRAY	18
TERMINAL STRIP	T1	SCREW	20	GRAY	18
CONTROL BOARD	J25	TAB	21	PURPLE	18
TERMINAL STRIP	T4	SCREW	21	PURPLE	18
TERMINAL STRIP	T4	SCREW	21	PURPLE	18
TERMINAL STRIP	T2	SCREW	21	PURPLE	18

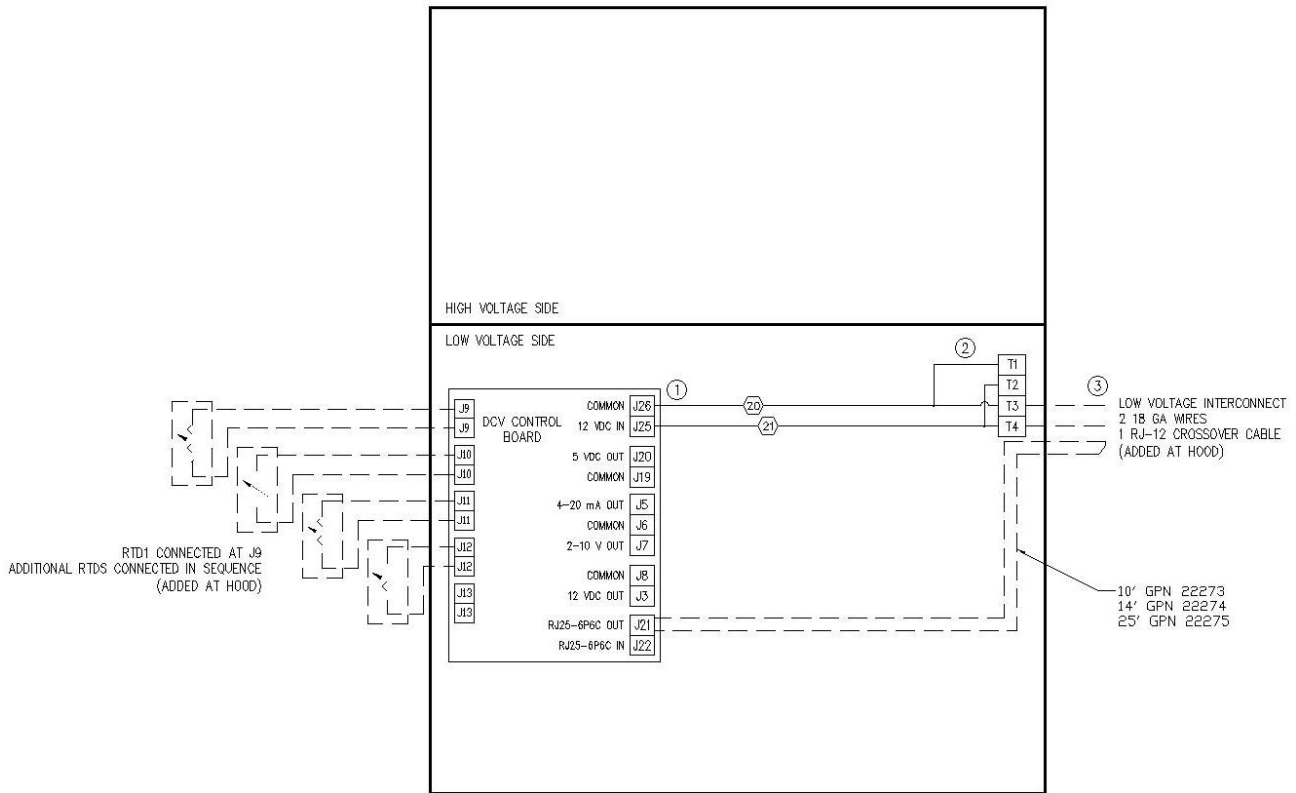
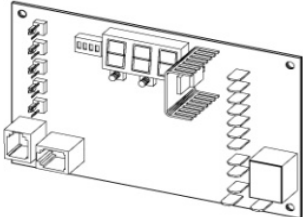
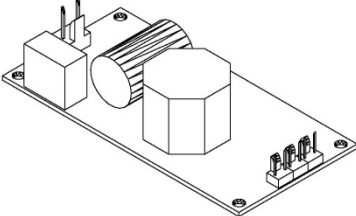
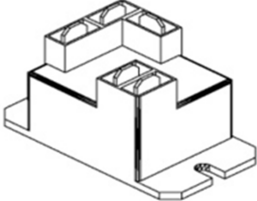



Figure 4-3-1: Secondary Control Box Wiring Diagram

This Page Intentionally Left Blank

Table 5-1-1: DCA Replacement Parts

Description	Gaylord Part #	Illustration
DCA Control Board	20318	
12 VDC Power Supply 25W	20883	
12 VDC SPST Relay	20885	
2A GMA Fuse	16821	N/A
RJ-12 Crossover Cable 10' 14' 25'	22273 22274 22275	N/A
RTD with Round Mounting Bracket as Illustrated	20319	

Limited Warranty

Effective February 19, 2015

The Gaylord DCA Series control system is warranted to be free from defects of material and workmanship under normal use when installed, operated, and serviced in accordance with factory recommendation.

The Manufacturer's obligation under this warranty and any warranties implied by law shall be limited to repairing or replacing at its option any part of said equipment when either Gaylord Industries, or the Licensed Gaylord Manufacturer's examination shall disclose to its satisfaction to be thus defective, for a period of one (1) year from the date of beneficial use, or eighteen months from date of shipment, whichever occurs first, provided proper and acceptable evidence of such is recorded at the factory. GAYLORD INDUSTRIES AND THE LICENSED GAYLORD MANUFACTURER SHALL NOT BE RESPONSIBLE FOR INCIDENTAL OR CONSEQUENTIAL DAMAGES RESULTING FROM A BREACH OF THIS WARRANTY.

In the United States, the labor required to make repairs and replacements under this warranty shall be furnished by Gaylord Industries or the Licensed Gaylord Manufacturer or its authorized representative. Such labor shall only be provided Mondays through Fridays during the hours between 8 a.m. and 4 p.m. Requests for repairs or replacement parts should be made to GAYLORD INDUSTRIES, 10900 SW AVERY STREET, TUALATIN, OR 97062, USA.

Outside the United States, all replacement parts furnished under this warranty shall be F.O.B. Gaylord Industries, Tualatin, Oregon U.S.A. The owner shall pay the necessary freight delivery charges, and necessary labor for removal and installation of parts, and any tariffs, duties or all taxes.

Component parts not manufactured by Gaylord Industries such as electrical switches, relays, solenoid coils, etc., shall be warranted under the terms and conditions of the warranty that is published by the manufacturer of said component parts.

This warranty does not cover routine maintenance and inspection of the cleaning system as spelled out in The Gaylord Ventilator Technical Manual. This warranty also does not cover malfunctions or improper operation caused by fluctuating electrical power or power surges.

This is the sole warranty with respect to the aforesaid items. NEITHER GAYLORD INDUSTRIES OR THE GAYLORD LICENSED MANUFACTURER OR ANY OTHER PARTY MAKES ANY OTHER WARRANTY OF ANY KIND WHATSOEVER, EXPRESSED OR IMPLIED, AND ALL IMPLIED WARRANTIES OF MERCHANTABILITY AND FITNESS FOR A PARTICULAR PURPOSE WHICH EXCEED THE AFORESAID OBLIGATIONS ARE HEREBY DISCLAIMED AND EXCLUDED FROM THIS AGREEMENT.

Service and Warranty Policies

1. No warranty work shall be performed on the product without a Purchase Order from Gaylord Industries, if financial reimbursement is to be requested.
2. No warranty shall be provided on equipment that has been started up and in operation for more the 90 days unless, a product maintenance schedule has been created and performed per the requirements of this technical manual.
3. Any, and all, wearable parts are not to be considered warranty items, regardless of installation date, unless previously authorized by the factory.

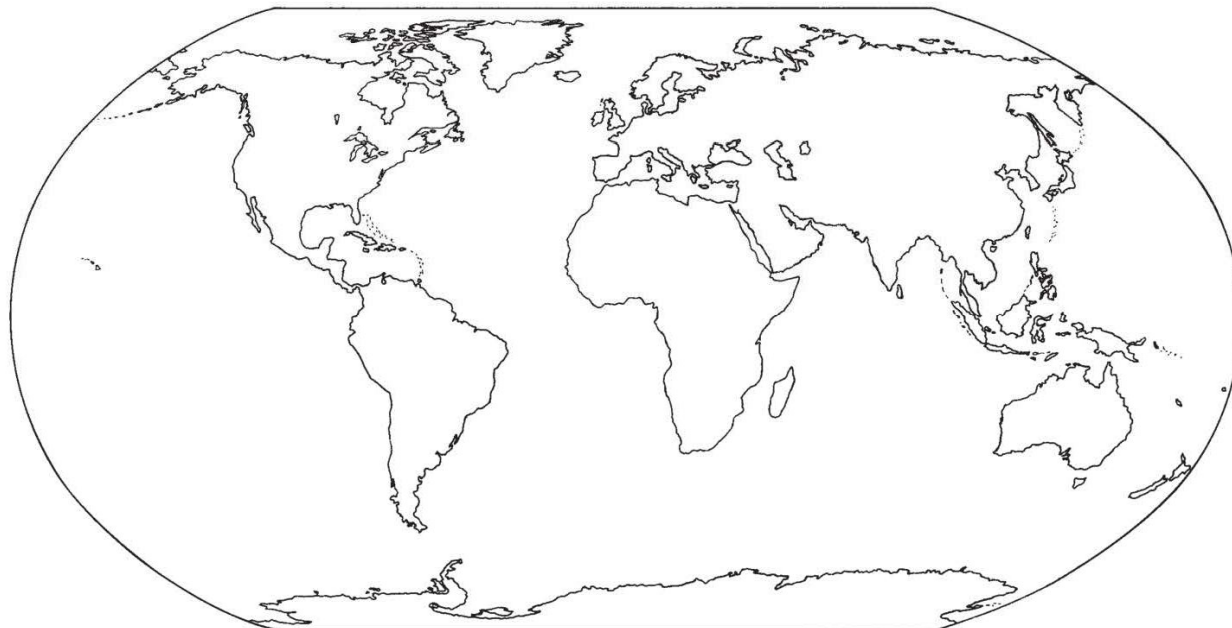

**WORLDWIDE SALES, MANUFACTURING AND SERVICE
FOR THE NAME AND LOCATION OF THE NEAREST
CERTIFIED SERVICE AGENCY, VISIT OUR WEB SITE:**

www.gaylordventilation.com

OR CONTACT US AT:

GAYLORD INDUSTRIES

10900 S.W. AVERY STREET
TUALATIN, OREGON 97062 U.S.A

email: info@gaylordventilation.com

Phone: 503-691-2010

800-547-9696

Fax: 503-692-6048

LOCAL SERVICE AGENCY