



Breathe easy.

**Operation, Maintenance
& Installation Manual
For
“EL” Series Commercial
Kitchen Exhaust Ventilators**

GAYLORD INDUSTRIES

10900 SW Avery Street – Tualatin, Oregon 97062 USA

Email: info@gaylordventilation.com Toll Free 800-547-9696 – Fax 5023-692-6048

www.gaylordventilation.com

All rights reserved. No part of this book may be reproduced, stored in a retrieval system, or transmitted in any form by an electronic, mechanical, photocopying, recording means or otherwise without prior written permission of Gaylord Industries.

©Copyright 2013, Gaylord Industries

The manufacturer reserves the right to modify the materials and specifications resulting from a continuing program of product improvement or the availability of new materials

Additional Copies \$25.00 Each



Breathe easy.

Gaylord Industries
10900 SW Avery St.
Tualatin, OR 97062
Office: 503.691.2010
Toll Free: 800.547.9696
www.gaylordventilation.com

To Our Customers:

Congratulations on your recent purchase of a Gaylord Model EL Series Ventilator. We are proud to be able to provide you with a quality product that exemplifies our long standing dedication to quality engineering and manufacturing.

Your Gaylord Ventilator is assembled from some of the very finest components available and is designed for years of efficient, effective and trouble free operation. In addition, the product has undergone rigorous quality inspections and testing prior to shipment.

If you have any questions, please contact us at info@gaylordventilation.com or by calling us toll free 800-547-9696. We are more than happy to help.

Sincerely,
Gaylord Industries

This Page Intentionally Left Blank

Table of Contents

Chapter 1 – Introduction

Introduction	1-1
Model Description	1-2
Model Number Explanation	1-3

Chapter 2 – Operation and Maintenance

Turning on Exhaust Fan	2-1
Turning off Exhaust Fan	2-1
Grease Extraction	2-2
Maintenance and Cleaning Instructions	2-3
Inspection and Cleaning Required by Code	2-4
Detergent for Cleaning	2-5
Fire Protection	2-6

Chapter 3 - Troubleshooting

Troubleshooting	3-1
-----------------------	-----

Chapter 4 – Testing and Repair

Measuring Airflow	4-1
Make-Up Air Guidelines	4-5
Balancing Dampers	4-7

Chapter 5 - Parts

Parts	5-1
-------------	-----

Chapter 6 – Wiring Diagrams

Wiring Diagrams	6-1
-----------------------	-----

Appendices

Installation Requirements	A-1
Post Installation Check List	B-1

This Page Intentionally Left Blank

Introduction

About this Technical Manual

The purpose of this manual is to provide the Operator, Maintenance and Service personnel instructions for operating, maintaining and troubleshooting the Gaylord Ventilator. This manual also includes information and guidance to contractors for the initial installation of the Ventilator.

The manual is divided into chapters for easy reference to a particular subject. The pages in the chapters are numbered with the chapter number then a dash and then the page number. So for example pages in Chapter 2 are numbered 2-1, 2-2, 2-3 etc. Figures and Tables are numbered in a similar manor. For example Figure 5-3-2 is on page 5-3 and is the second figure. Please keep your manual in a convenient location for so it can be accessed easily.

If you have any questions or concerns with the installation, operation, maintenance or service of your Gaylord Ventilator, please contact Gaylord Industries;

Web: www.gaylordventilation.com

E-mail: info@gaylordventilation.com

Main Phone: 503-691-2010 Toll Free: 800-547-9696

Safety

It is important that the operator read Chapter 2, Operation and Maintenance, before operating the Ventilator for the first time. Particular attention should be given to all the **Caution** and **Warning** statements.

Related Technical Manuals

1. EL Series Ventilators installed in the United States typically include a Gaylord Autostart Control. In some instances Ventilators installed outside the United States will include an Autostart Control. To determine if the Ventilator includes an Autostart Control refer to page 1-3 and the Nameplate mounted on the Ventilator (Refer to Figure 4-4-1). The specific manual for this control is titled **Operation and Maintenance Manual for the Gaylord Autostart Control**.
2. EL Series Ventilators may be used in combination with Gaylord ELX or ELXC Series Ventilators. In this case the exhaust fan would be controlled by a Gaylord Command Center. The specific manual for the Command Center is titled **Operation, Maintenance and Installation Manual for the Gaylord Command Center and Wash Control Cabinet**. Use this manual for all exhaust fan start and stop functions.

Operation and Maintenance Manuals may be downloaded from the Gaylord website: www.gaylordventilation.com or be obtained by calling Gaylord Industries.

Model Description

Overview

The Gaylord Model EL Series Ventilator uses a Listed aluminum baffle filters as a standard or as an option stainless steel filters, Gaylord XGS high efficiency Extractors, or spark arrester filters.

The EL Ventilators come in many different models, some of which are illustrated below. Your Ventilator may appear slightly different as they may have been custom designed to fit the space and application.

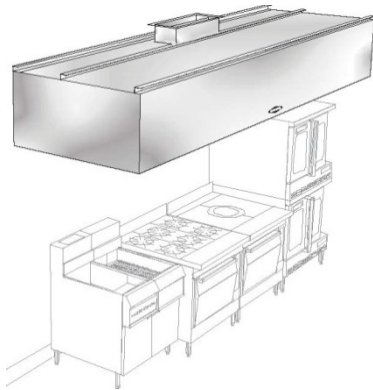

Figure 1-2-1
Model EL Series
Wall mounted Canopy Style

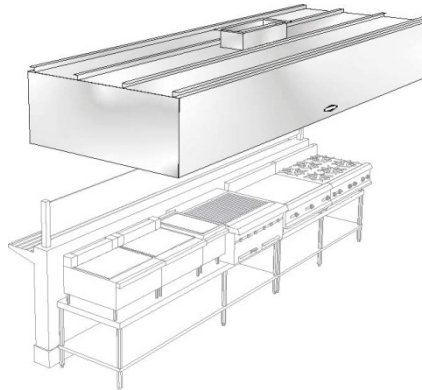

Figure 1-2-2
MODEL EL-BBC-CL Series
Island Style for Single Island
Arrangement

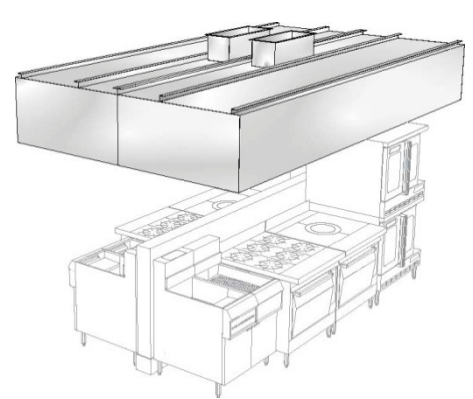

Figure 1-2-3
MODEL EL-BB Series
Island Style for Double Island
Arrangements

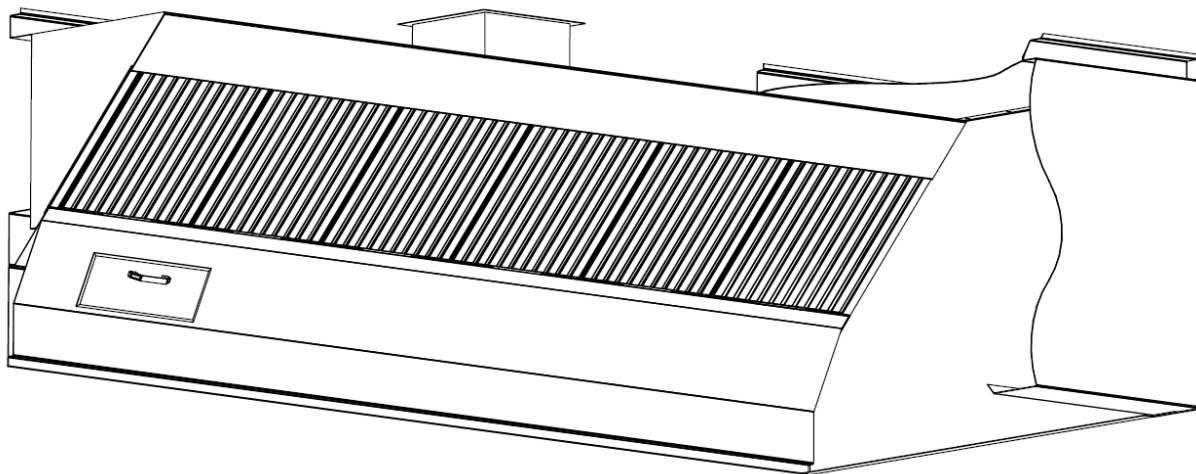

Figure 1-2-4
Cut-away view of Canopy Style Ventilator

Model Number Explanation

Model Number Sequence

Gaylord Ventilator model numbers are made up of an alphabetic prefix followed by a series of alphabetic and/or numeric suffixes to designate the style of ventilator and various options. Sequence of model numbers is as follows.

1. _____	2. _____	3. _____	4. _____	5. _____	6. _____	7. _____	8. _____	9. _____
Series	Damper Type	Style	Front Lip Design Option	Canopy Profile	Filter Option	Controls	Material Type	Hood Depth (in)

Definition of Prefixes and Suffixes

1. Series

EL..... Non-water-wash Ventilator with UL 1046 filters.

2. Damper Type

SD..... Listed Slide Gate Balancing Damper located at the duct collar (*Standard*).

ND..... No Damper.

GEBD Gaylord Electric Balancing Damper.

GBD Gaylord Balancing Damper.

3. Style

Blank Wall Mounted Canopy Ventilator.

CL Island Ventilator for single line of cooking equipment using a single plenum chamber.

BBC-CL..... Island Style for single line of equipment using one plenum chamber with one common exhaust duct.

BB Island Style for double line of equipment using two plenum chambers and two separate exhaust ducts.

4. Front Lip Design (*Front lower edge of the hood*)

S Square front with 6" "Super Capture" lip (*Standard*).

Blank Facetted front design with 6 inch return flange (*3 Break or greater 90° at front lip*).

5. Canopy Profile

Blank **Standard Profile** - 30 inch or greater canopy height.

MP **Medium Profile** - 24 inch front height. Rear height range from 24" to 30" inches tall.

LP **Low Profile** - 12 inch to 23 inch front height. Rear height range from 24" to 30" tall.

6. Filter Option

AL Uses Aluminum Baffle filters (*Standard*).

SS Uses Stainless Steel Baffle Filters.

XGS Uses 18" tall Gaylord XGS high efficiency Extractors.

SPB..... Uses a listed NFPA-96 accepted spark arresting baffle filter.

Definition of Prefixes and Suffixes – Cont.

7. (Controls) Automatic Start/Demand Control Option

- Blank**..... **No Autostart** - Does not have Autostart system.
- AS**..... **Autostart** - Ventilator has Autostart utilizing bi-metallic thermostats.
- DCA**..... **Demand Autostart** - Ventilator has Autostart utilizing RTD's and a hood mount circuit board.
- DCV-F**..... **Demand Control Fan** - Ventilator is equipped with RTD's to connect to DCV-F system.

8. Material Type

- 300** Indicates 300 Series Stainless construction.
- 400** Indicates 430 Series Stainless construction.

9. Hood Depth (Front to back dimension of Ventilator)

- (##.###)**..... Value in inches to indicate the Ventilator depth.

Turning On the Exhaust Fan

Caution: Always turn on the exhaust fan before turning on the cooking equipment.

Caution: The chemical fire extinguishing system may discharge if the exhaust fan is not on while the cooking equipment is on or still hot.

Caution: Never operate your Ventilator without the Grease Filters in place. Refer to Figure 2-1-1.

To operate the exhaust fan flip the fan switch to the ON position. The switch is typically mounted on a wall near the Ventilator or it may be mounted on the face of the Ventilator.

Note 1: The EL Series Ventilator may be equipped with a Gaylord Electric Balancing Damper, designated “GEBD” in the Ventilator model number. The Ventilator model number can be found on the Ventilator Nameplate (Refer to Figure 4-4-1 for a sample of the nameplate and to Page 4-7 for information on Balancing Dampers). If the Ventilator includes this damper, when the fan is started the damper moves from the closed to open position and it will take approximately 45 seconds for the exhaust to come up to 100%.

Note 2: Typically EL Series Ventilators installed in the United States are equipped with a Gaylord Autostart Controller Model AS or DCA that automatically turns on the exhaust fan if the temperature at the sensors mounted in the canopy exceeds 90°F. (Refer to Figure 2-2-1). In some instances Ventilators installed outside the United States will include an Autostart Control. Inclusion of an Autostart Control is designated by the suffix AS or DCA in the model number. The Ventilator model number can be found on the Ventilator Nameplate (Refer page 4-4-1 for a sample of the Nameplate). Refer to the Operation, Maintenance and Installation Manual for the Gaylord Command Center for complete information on the Autostart Control.

Note 3: If Gaylord model ELX-UVi or ELXC Series Ventilators are connected to the same exhaust fan as an EL Series, then the exhaust fan would be controlled by a Gaylord Command Center. The manual for the Command Center is titled **Operation, Maintenance and Installation Manual for the Gaylord Command Center and Wash Control Cabinet**. Refer to this manual for instructions for turning on and off the exhaust fan.

Turning Off the Exhaust Fan

Caution: Always turn off the cooking equipment and allow cooling before turning off the exhaust fan. The chemical fire extinguishing system may discharge if the cooking equipment is on or hot when the exhaust fan is off.

At the end of the cooking day, turn off the cooking equipment and allow cooling before turning off the exhaust fan. To turn off the exhaust fan flip the fan switch to the OFF position

Note 1: If the Ventilator includes a Gaylord Autostart Controller the exhaust fan will stay on if the temperature at the duct collar is above 90°F. Once the temperature drops below 90°F., the fan will continue to run for 20 to 60 minutes and then shut off.

Note 2: If the Ventilator is equipped with a Gaylord Electric Balancing Damper, designated GEBD, when the fan is turned off the damper will move from the open to the closed position, and remain closed until the exhaust fan is re-started. Closing the damper saves building energy by not allowing conditioned air from drafting up the exhaust duct, or in cold climates prevents cold air from coming down the duct and into the kitchen.

Grease Extraction

Grease is extracted by either Listed Grease Filters or by the use of Gaylord Model XGS Extractors. Grease is removed from the exhaust air by centrifugal force as it passes through the filter. The hot grease laden contaminated air rising from the cooking surface is drawn through the filters where a percentage of the grease and other particulate are extracted from the airstream. The extracted liquid grease will drain down the filters and into the Grease Gutter which then drains to the Grease Drawer. The sticky grease will remain in the filters until cleaned.

The optional Gaylord Model XGS Extractor provides significantly higher grease extraction efficiency than the Listed Grease Filters. The Extractors are ETL Recognized as part of the EL Ventilator. They are constructed of corrosion resistant stainless steel.

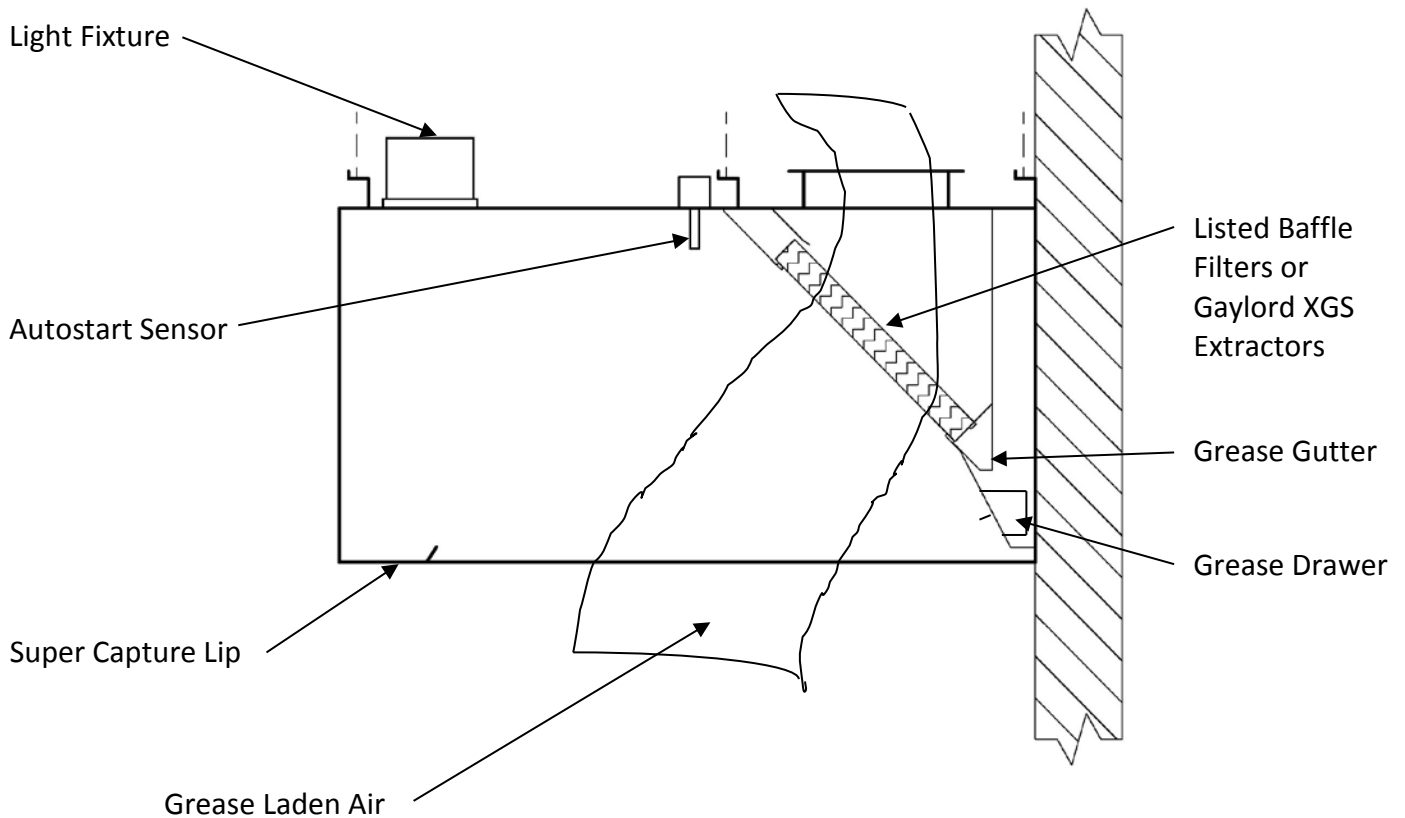

Figure 2-2-1
Grease Extraction

Maintenance and Cleaning Instructions

Overview

To maintain the Gaylord Ventilator in good working order, and to keep the system operating at optimum efficiency, preventive maintenance using the following schedule should be performed.

Daily Cleaning and Maintenance

At the end of the each cooking day, or at periodic intervals, depending upon the type of cooking, the filters or XGS Extractors must be removed and cleaned. **Caution:** Before removing the filters/Extractors check to see that the exhaust fan is shut off and the cooking equipment is cool. To remove the filters/Extractors and clean proceed as follows:

1. Remove filters/Extractors: **Caution:** Care should be taken when removing the filters/Extractors, especially over fryers. It is recommended that the cooking equipment be cooled down and the fryers be covered prior to removing. They may be removed by hand or by use of an optional Filter/Extractor Removal Tool (Refer to Figure 2-3-2). To remove, lift up slightly on the Filter/Extractor and pull out from the bottom, then straight down.
2. The Filter/Extractor may be cleaned either by using a dishwasher or by soaking in a deep well sink using hot water with a degreasing detergent, scrubbed and rinsed. Gaylord Formula G-510EF detergent is highly recommended for this application. Refer to Page 2-5 for details.
3. With the filters/Extractors removed inspect the back wall and the underside of the exhaust plenum. If necessary clean with hot detergent water.
4. Wipe and clean the Grease Gutter.
5. Remove and empty the Grease Drawer and replace.
6. Replace the filters or Extractors. **Important Note:** Filters and Extractors must be installed with the openings running vertical as shown in Figure 2-3-1. Gaylord XGS Extractors have an arrow stamped on the face designating "UP".
7. Wipe the interior surfaces of the hood as required.

Filters or Extractors must be installed with openings running vertical as shown below

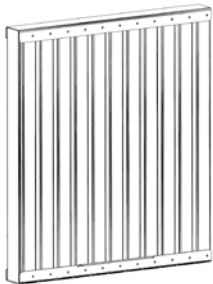

Figure 2-3-1
Typical Filter or
Gaylord Extractor

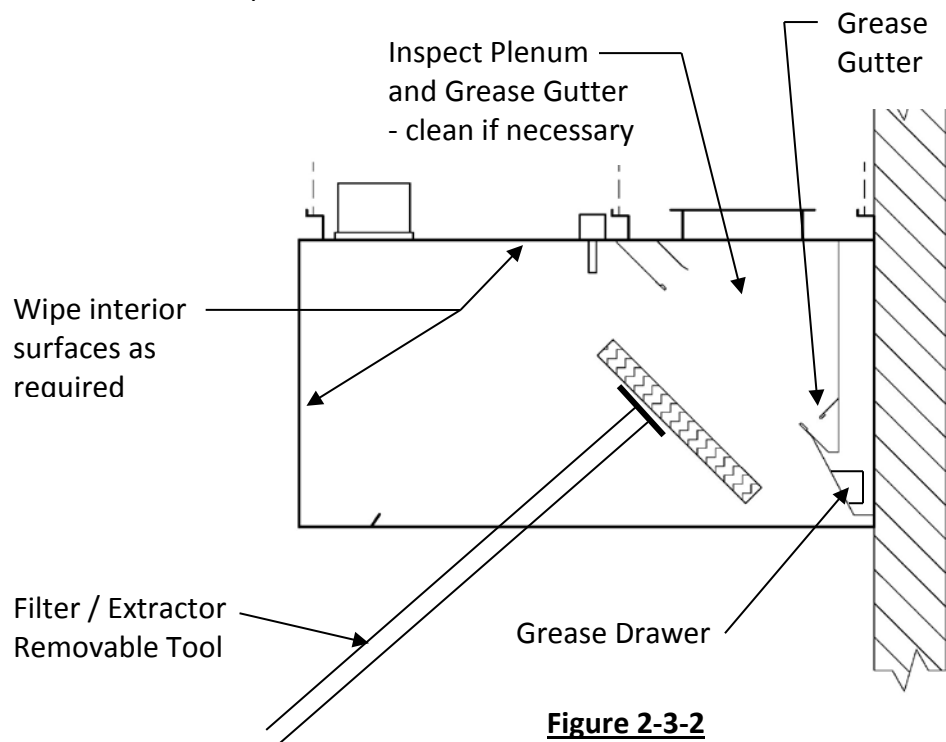

Figure 2-3-2
Cleaning

Inspection and Cleaning Required by Code

NFPA-96 (Standard for Ventilation Control and Fire Protection of Commercial Cooking Operations) require that hoods, ducts and exhaust fans be inspected by a properly trained, qualified and certified company or person(s) in accordance with the following table.

Table T-2-4-1

EXHAUST SYSTEM INSPECTION SCHEDULE	
Systems serving solid fuel cooking operations	Monthly
Systems serving high-volume cooking operations such as 24-hour cooking, charbroiling or wok cooking	Quarterly
Systems serving moderate-volume cooking operations	Semi-annually
Systems serving low-volume cooking operations, such as churches, day camps, seasonal businesses, or senior centers	Annually

NFPA-96 states “Upon inspection, if found to be contaminated with deposits from grease-laden vapors, the entire exhaust system shall be cleaned by a properly trained, qualified, and certified company or person(s) acceptable to the authority having jurisdiction”.

“When a vent cleaning service is used, a certificate showing date of inspection or cleaning shall be maintained on the premises. After cleaning is completed, the vent cleaning contractor shall place or display within the kitchen area a label indicating the date cleaned and the name of the servicing company. It shall also indicate areas not cleaned”.

Factory trained service agencies are certified by Gaylord Industries to perform these inspections. For the name and phone number of your nearest agent, call 1-800-547-9696 or go to; www.gaylordventilation.com/Service_Agencies/.

Detergent for Cleaning

FORMULA G-510EF is the only cleaner recommended by Gaylord Industries for use in the wash down system of The Gaylord Ventilator. FORMULA G-510EF is a concentrated colloid cleaner specially formulated to remove the daily accumulation of grease inside the Ventilator without damaging the rubber and synthetic parts of the solenoid valves and the detergent pumping system. FORMULA G-510EF is safe for kitchen personnel and has a variety of uses.

FORMULA G-510EF is registered with the U.S. EPA's Design for the Environment Program (DfE) which seeks to promote the use of institutional cleaners and maintenance products with improved environmental and human health characteristics.

Cleaning the Filters/Extractors

The filters/Extractors may be cleaned by running them through a dishwasher or by soaking in a deep well sink. To soak proceed as follows:

1. Place the filters/Extractors in a deep well sink.
2. Pour in 2-3 cups of FORMULA G-510EF.
3. Fill sink with hot water until the water covers the filters/Extractors.
4. Let soak for 15-30 minutes.
5. Scrub and rinse.
6. Repeat if necessary.

FORMULA G-510EF for Cleaning the Ventilator Exterior

Mix one part FORMULA G-510EF to twenty parts water in hand spray bottle. Spray on, let stand for a few minutes and wipe off.

FORMULA G-510EF for Other Cleaning Jobs

The colloidal action of FORMULA G-510EF makes it a cleaner especially well-suited for use in kitchens. The colloids break up dirt and grease into millions of tiny particles that constantly repel each other. These particles cannot recombine or redeposit on a surface and are, therefore, easily washed away. FORMULA G-510EF contains no harsh chemicals, yet offers outstanding performance on the toughest cleaning jobs.

Use a mixture of one part FORMULA G-510EF to twenty parts water for:

- VINYL/PLASTIC/WALLS...Removes dirt, grease, food deposits and fingerprints.
- REFRIGERATORS...Removes dirt, spilled milk, blood, mildew and objectionable odors.
- RESTROOMS...Add a disinfectant to clean all fixtures, walls, floors, etc.

Use a mixture of one part FORMULA G-510EF to five parts water for extremely heavy grease build-up, such as on the floor and on equipment around deep-fryers. Spray on, let set for a few minutes and rinse or wipe off. For extremely soiled areas, gentle agitation, followed by a soaking period, will result in more thorough cleaning. DON'T be afraid to experiment with FORMULA G-510EF because it contains no phosphates, nitrates, enzymes, sulfates, suffocates or silicates.

FORMULA G-510EF Distributor

For the name and address of the nearest FORMULA G-510EF distributor contact:

Gaylord Industries
10900 SW Avery Street
Tualatin, OR 97062

E-mail: info@gaylordventilation.com
Website: www.gaylordventilation.com
Phone: 800-547-9696

Fire Protection

Fire Extinguishing Systems

The National Fire Protection Association Standard 96 (NFPA-96) and the International Fire Code (IFC) requires the use of a Fire Extinguishing System to cover the cooking surfaces, Ventilator exhaust plenums (the area behind the filters/Extractors), and the exhaust duct (Refer to Figure 2-7-1). Upon activation, of the Fire Extinguishing System the follow will occur:

1. Fire extinguishing agent will discharge through the cooking equipment nozzles, the plenum nozzle(s) and the duct nozzle(s) (Refer to Figure 2-7-1).
2. The protected cooking equipment and possibly other cooking equipment will shut off. Refer to the above referenced codes for specific equipment that must shut off.
3. If the Fire Extinguishing System is wired to a building fire alarm system the alarm will activate.
4. If the Fire Extinguishing System is wired to a building management system it will notify of a fire condition.
5. If the Fire Extinguishing System is wired to the Makeup-Air fan it will shut off.
6. If the Ventilator is equipped with a Gaylord Electric Balancing Damper model GEBD the damper will open.
7. After discharge, the Fire Extinguishing System must be recharged and certified by a fire system contractor, and the cooking equipment cleaned before the cooking equipment can be turned back on.

For Operation and Maintenance of the Fire Extinguishing System, refer to the system manufactures Owner's Manual.

Important: NFPA-96 requires inspection and certification of fire systems every 6 months.

Fire Protection – Cont.

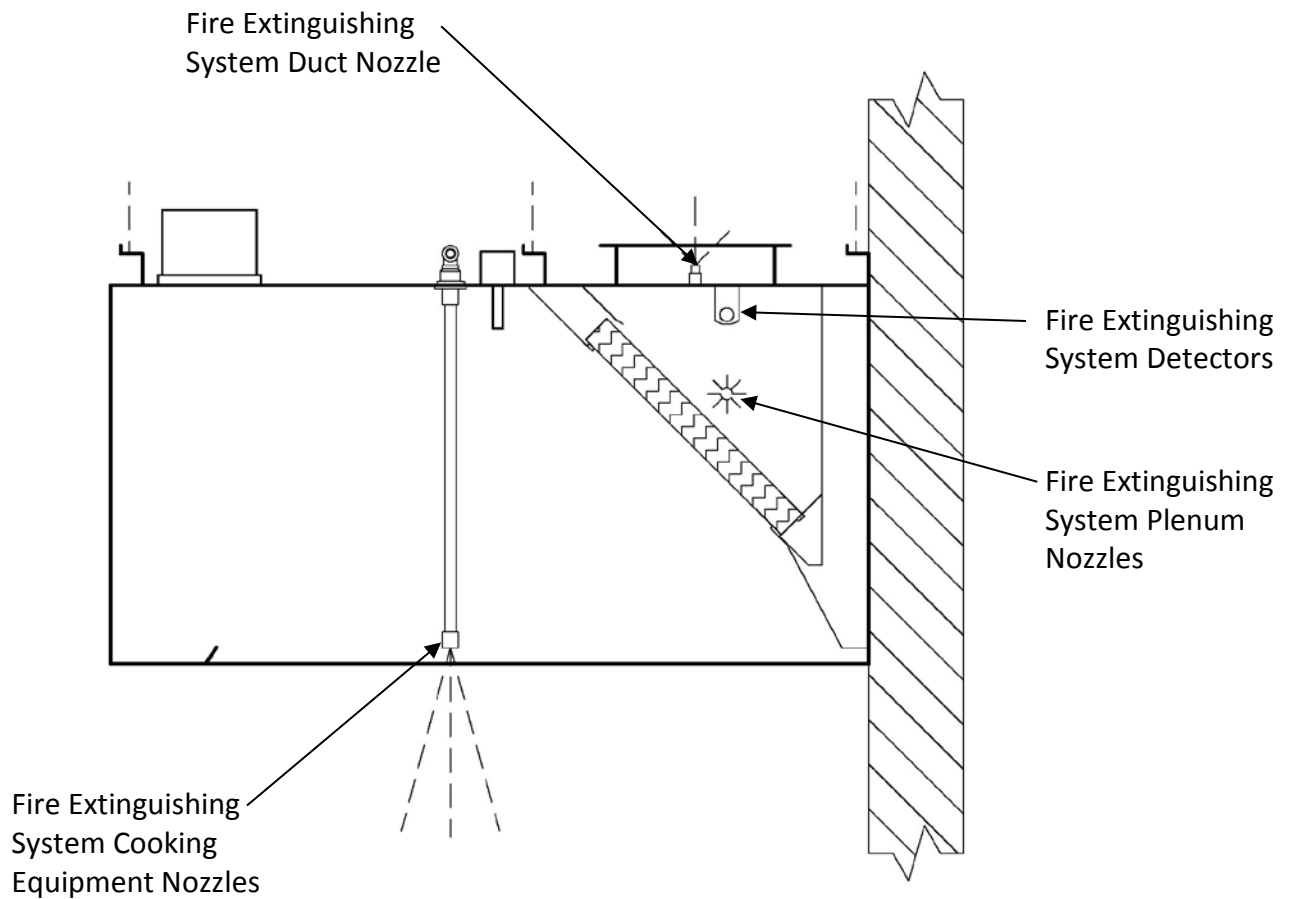

Figure 2-7-1
Fire Extinguishing System Discharge

This Page Intentionally Left Blank

Troubleshooting

The following Troubleshooting Charts are designed to easily find common problems, the probable cause and guidance for corrective action. In some cases the Corrective Action column will reference the Testing and Repair section of this manual for additional guidance and actions.

SMOKE LOSS		
SYMPTOM	PROBABLE CAUSE	CORRECTIVE ACTION
1 The Ventilator is not exhausting all the smoke, heat and grease properly.	A. Exhaust volume is low due to fan performance issues or a Gaylord Balancing Damper, is not adjusted properly. Measure the exhaust volume as described on page 4-1 through 4-4.	1 Check exhaust fan for broken or slipping belts. Adjust or replace belts as required.
		2 Confirm proper rotation of fan wheel.
		3 Check for proper size of exhaust fan. Fan must deliver Ventilator Nameplate rating.
		4 Check and adjust Gaylord Balancing Damper as described pages 4-7 through 4-9 of this manual.
		5 Check for open access panel in duct system and close or re-install if open.
	B. Exhaust volume is low due to a heavy grease accumulation in the Filters/Extractors.	1 Remove the Extractors and inspect for grease accumulation. Clean if necessary. Refer to page 2-3 for guidance.
	C. The Ventilator must have its own exhaust system and no other exhaust, such as dishwasher hoods should be tied into it.	1 Inspect the duct system and verify that there are no other non-Ventilator systems tied in. If so they must be removed.
	D. Improperly placed make-up air diffusers.	1 Makeup-Air directed at the Ventilator will likely create cross drafts disrupting the air flow into the Ventilator. Adjust the louvers to direct the make-up air away from the Ventilator. Refer to page 4-5 for guidance.
		2 Makeup-Air should be delivered through registers at ceiling height, and distributed throughout the kitchen area. Refer to page 4-5 for guidance.

Troubleshooting - Cont.

<p>The Ventilator is not exhausting all the smoke, heat and grease properly.</p>	<p>D. Improperly placed make-up air diffusers.</p>	<p>3 Makeup-Air registers located near the Ventilator, the louvers should be adjusted to direct the air away from the Ventilator. Directing or forcing the Makeup-Air at the Ventilator typically creates cross drafts resulting in cross drafts. Refer to page 4-6 for guidance.</p>
	<p>E. Inadequate make-up air.</p>	<p>1 Makeup-Air must be supplied for replacement of air exhausted through all kitchen exhaust systems. Refer to page 4-5 for guidance.</p>
		<p>2 A general "rule of thumb" is that 75%to 80% of the replacement air should be fresh, conditioned, (heated or cooled) air brought into the kitchen area, with the remaining 20% to 25% allowed to flow into the kitchen from adjacent areas. Refer to page 4-5 for guidance.</p>
	<p>F. Exhaust fan discharge.</p>	<p>1 There should be no screen over the discharge. If one is found, it should be removed.</p>
		<p>2 The direction of discharge should not be into the prevailing winds or downward onto the roof. A vertical discharge is highly recommended.</p>

<p>GREASE EXTRACTION</p>		
<p>SYMPTOM</p>	<p>PROBABLE CAUSE</p>	<p>CORRECTIVE ACTION</p>
<p>1 Poor grease extraction.</p>	<p>A. Ventilators exhausting too much air can cause an excessive amount of noise and allow grease to be pulled through the filters/Extractors. Ventilators exhausting below design will also allow grease to be pulled through the filters/Extractors.</p>	<p>1 Check for proper exhaust volume by following the instructions beginning on page 4-1.</p>

Troubleshooting - Cont.

Poor grease extraction.	B. Sticky grease may have accumulated within the filters/Extractors, creating a higher velocity within the filters/Extractors allowing grease to be pulled through.	1 Remove the Filters and inspect for grease accumulation. Clean if necessary. Refer to page 2-3 for guidance.
-------------------------	---	---

EXHAUST FAN		
SYMPTOM	PROBABLE CAUSE	CORRECTIVE ACTION
1 If when the fan switch is turned to the Fan On position but the exhaust fan does not come on.	A. Overload protector on the magnetic starter has tripped	1 Push the "Reset" button on the magnetic starter and turn the fan switch to the Fan On position.
	B. If the HOA (Hands Off/Automatic) type magnetic starter switch is used, the selector switch may have been moved from the automatic position.	1 Check the switch and turn the selector to the automatic position.
	C. Exhaust fan circuit breaker tripped.	1 Re-set circuit breaker.
	D. If the system is equipped with a fused disconnect switch for the exhaust fan, a fuse or fuses may have blown out.	1 Check continuity of fuses and replace if necessary.
	E. Fan On/Off switch gas not been wired properly.	1 Refer to the wiring diagrams beginning on page 6-1.
2 If the exhaust fan has been started and air is not being pulled through the Ventilator but you can hear the fan running.	A. If the Ventilator is equipped with balancing damper, the damper may be closed or closed down too far.	1 Check the balancing dampers. For guidance refer to the instructions beginning on page 4-7.
	B. If the Ventilator is equipped with an electric balancing damper the damper closes each time the fan is stopped. The damper may not be re-opening when the fan is started.	1 Remove the filter/Extractor nearest the exhaust duct collar. Start the fan and observe the damper. If the damper does not move to a partially open or fully open position, there is either a mechanical or electrical malfunction. Troubleshoot and take corrective action.

Troubleshooting - Cont.

Poor grease extraction.	B. Fan drive belt is slipping.	1 Tighten the belt and then measure exhaust volume to verify. Refer to instructions on measuring exhaust volume beginning on page 4-1.
	C. Fan is running in reverse.	1 Contact electrical contractor to wire correctly.

Measuring Airflow

Overview

EL Ventilators are factory engineered to operate at a specific exhaust volume, CFM (Cubic Feet per Minute), based on, primarily, the type of cooking appliance, and the exact model of the Ventilator. Smoke capture, grease extraction efficiency and heat removal are dependent upon the proper exhaust volume (Airflow) through the Ventilator. If the exhaust volume is below design, smoke, grease and heat may escape the confines of the Ventilator creating an uncomfortable kitchen for the operators. It will also reduce the grease extraction efficiency of the filters/Extractors resulting in additional grease depositing in the duct system and exhaust fan. This can lead to sanitation problems and fire hazards if left uncorrected. If the exhaust volume is higher than design, more energy will be used to operate the exhaust fan, excessive noise levels will result, and grease can be pulled through the filters/Extractors depositing in the duct and fan. Operating the Ventilator at higher or lower airflows than design will result in the entire kitchen ventilation system being out of balance.

It is important that at initial installation of the Ventilator the exhaust volume is measured to verify that it meets design. It is also recommended that the exhaust volume be measured once every two or three years to insure that the exhaust fan is operating properly. The exhaust volume for each Ventilator section is stamped on the Ventilator Nameplate (Refer to Figure 4-4-1).

Instrument Used to Measure Airflow

The standard instrument used for measuring the filter/Extractor velocities of a Gaylord Ventilator is a Pacer Model DA400, 2.75" Rotating Vane Anemometer (Refer to Figure 4-2-1). A Gaylord standoff bracket part number 21827 (Refer to Figure 4-2-2) is used only when measuring airflow for Ventilators that use Baffle Filters. Both the Pacer Anemometer and standoff bracket are available from the Gaylord Parts Department. For alternate methods of measuring the airflow, such as flow grids or hoods, consult that equipment's user manual for specific details on how to determine airflow.

Measuring the Airflow

The Ventilator exhaust volume may be determined by measuring the inlet velocity of the Baffle Filters or Gaylord XGS Extractors and applying that value to a formula converting velocity, in FPM, to an exhaust volume in CFM. To measure the velocity and confirm the exhaust volume, proceed as follows

1. For safety purposes turn off the cooking equipment and allow cooling.
2. Confirm that all filters are clean and in place.
3. Prior to measuring, close all doors and windows leading to the kitchen. Activate the supply, exhaust and any associated HVAC system fans.
4. Attach the cable to the sensing head.
5. Attach the cable from the sensing head to the meter.
6. Attach the handle sections to the sensing head.
7. **Important:** If the Ventilator is equipped with Listed Baffle Filters install the 2 inch standoff bracket, GPN 21827, as shown in Figure 4-2-2 to the sensing head. This will create a 2" standoff between the sensing head and the Baffle Filter. **Very Important Note: If the Ventilator is equipped with Gaylord XGS Extractors do not install the 2" standoff bracket.**
8. Beginning at the left Baffle Filter or Extractor, called Filter No. 1, place the standoff or sensing head directly against the face of the Baffle Filter/Gaylord Extractor as shown in Figure 4-2-3.

Measuring Airflow – Cont.



Figure 4-2-1
Pacer Model DA400
Anemometer

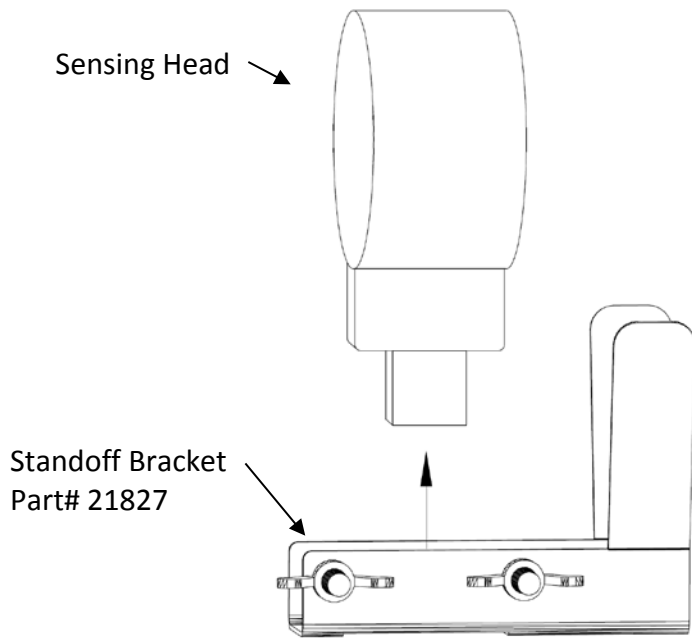

Figure 4-2-2
Gaylord Standoff Bracket
Used on Baffle Filters Only

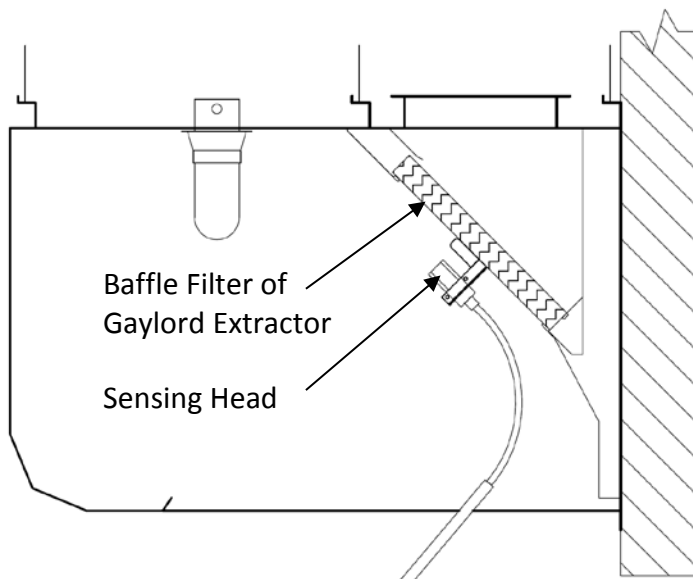

Figure 4-2-3
Standoff Bracket or Sensing Head Against
Filter or Extractor

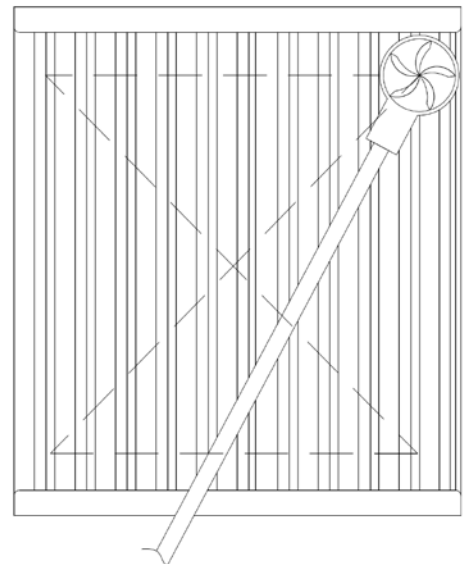

Figure 4-2-4
“X” Pattern for Measuring
the Velocity of Baffle Filters
or Gaylord Extractors

Measuring Airflow – Cont.

9. Using the 16 second averaging feature on the meter, slide the sensing head in a “X” pattern as shown on Figure 4-2-4, slowly, at a rate that would last roughly 16 seconds. If you reach the end of the “X” pattern before the 16 second interval has elapsed, continue moving the sensing head back the other direction (without removing it) until the 16 second time interval has expired.
10. At the end of 16 seconds an average velocity will appear on digital readout of the meter.
11. Record the average velocity and identify as Filter No. 1.
12. Repeat the process for the remaining filters, No. 2, 3 etc.
13. (Optional) If the cooking equipment is operating or the kitchen is exceptionally hot or cold, record the temperature of the air going into the filters to be used in determining the SCFM if necessary. Use a handheld thermocouple reader to take the values and average them together.
14. Upon completing average velocity readings for each filter, add the readings together for a total. Then divide this total by the number of filters. The result is called the Total Average Velocity (TAV).

Formula for Determining Total Average Velocity (TAV)

$$TAV = V1+V2+V3 \text{ etc. } \div \# \text{ of Baffle Filters or Extractors.}$$

15. Calculate the total Ventilator CFM by using one of the following formulas:

Where:

CFM = Cubic Feet per Minute (total exhaust volume).

TAV = Total Average Velocity (of the Baffle Filters or Gaylord XGS Extractors).

FA = Filter Area in sq. ft. **Note:** Baffle Filter Area = 1.67 sq. ft. per filter.

Gaylord XGS Extractor = 1.24 sq. ft. per Extractor.

NOF = Number of Baffle Filters or Gaylord XGS Extractors.

Formula for Baffle Filters

$$CFM = TAV \times 1.67 \times NOF$$

Example:

The Ventilator is 11 feet long and has 8 Baffle Filters with average velocities of 236, 216, 243, 288, 316, 302, 271, & 266. The total velocity average is 276 FPM. The cooking equipment is on with the average inlet temperature of 105° F. The airflow will equal:

$$CFM = TAV \times 1.67 \times NOF$$

$$CFM = 276 \text{ FPM} \times 1.67 \times 8 = 3687 \text{ ACFM}$$

To correct for standard conditions:
 $(3687 \times 532) \div (105F + 460) = 3471 \text{ SCFM}$

Formula for Gaylord XGS Extractors

$$CFM = TAV \times 1.24 \times NOF$$

Example:

The Ventilator is 11 feet long and has 8 Gaylord XGS Extractors with average velocities of 336, 316, 343, 388, 416, 402, 371, & 366. The total velocity average is 367 FPM. The cooking equipment is on with an average inlet temperature of 105° F. The airflow will equal:

$$CFM = TAV \times 1.24 \times NOF$$

$$CFM = 367 \text{ FPM} \times 1.24 \times 8 = 3640 \text{ ACFM}$$

To correct for standard conditions:
 $(3148 \times 532) \div (105F + 460) = 3427 \text{ SCFM}$



Note: If the air entering the baffles is greater than 100F or less than 60F, then multiply the CFM by 532 ÷ (TEMP_{IN} + 460) to get SCFM as shown in the examples above. **Note:** Testing under hot or cold conditions can be corrected to SCFM for better comparison with the balancer’s data

Measuring Airflow – Cont.

16. Compare the measured CFM with the CFM stamped on the Ventilator Nameplate (refer to Figure 4-4-1). The acceptable range is 0% low and 10% high. If the CFM is not within acceptable range then corrective action must be taken to bring the exhaust volume within design. Typically low or high exhaust volumes are caused by one of the following:
- a) The exhaust fan may not be operating properly. Refer to the Troubleshooting section, beginning on page 5-1 for possible problems and corrective action.
 - b) If the Ventilator has a Balancing Damper and if the determined CFM is low, the Balancing Damper needs to be opened slightly. If the determined CFM is high the Balancing Damper needs to be closed slightly. Refer to page 4-7 for instructions on adjusting Balancing Dampers. **Important Note: If the exhaust fan is connected to more than one Ventilator section, keep in mind that as one damper is adjusted it will affect the exhaust volume in the remaining Ventilator sections, so making minor adjustments and coming back and retaking airflow readings is highly recommend.**
 - c) Continue either opening or closing the Balancing Damper until the airflow is within the acceptable limits.

Total Exhaust Volume Here



Intertek
42106

THIS EXHAUST HOOD HAS BEEN TESTED TO STANDARD UL 710 "EXHAUST HOODS FOR COMMERCIAL COOKING EQUIPMENT"

THIS HOOD IS LISTED UNDER INTERTEK ETL SEMKO REPORT NUMBER 3130583CRT-008. FOR ADDITIONAL INFORMATION, GO TO WWW.INTERTEK-ETLSEMKO.COM

THIS HOOD MEETS ALL REQUIREMENTS OF THE LATEST EDITION OF NFPA-96 AND IMC (INTERNATIONAL MECHANICAL CODE)

GAYLORD INDUSTRIES
10900 S.W. AVERY STREET
TUALATIN, OR 97062 USA
(503) 619-2010
EMAIL: info@gaylordusa.com
www.gaylordusa.com

EL-1212 / 21829

EL SERIES ENGINEERING DATA

MODEL NO. EL-	
SERIAL NO.	
<input type="checkbox"/> (20 X 16) AL BAFFLE	<input type="checkbox"/> (20 X 16) SS BAFFLE
<input type="checkbox"/> (18 X 16) XGS	NUMBER: _____
1. MIN SUGGESTED TOTAL EXHAUST VOLUME FOR THIS SECTION	C.F.M.
2. EXHAUST STATIC PRESSURE AT DUCT COLLAR	W.G.

MAXIMUM COOKING SURFACE TEMPERATURE	400°F	600°F	700°F
CANOPY HT.	LISTED MIN VALUES IN CFM/LF OF HOOD		
24" MINIMUM	117	162	195
24" MINIMUM W/ SIDE PANELS	117	140	195
30" MINIMUM	96	136	150
30" MINIMUM W/ SIDE PANELS	96	122	136
12" MINIMUM LP - LOW PROFILE	155	211	261
24" MINIMUM CL SERIES (SINGLE ISLAND)	195	241	---
30" MINIMUM BBC SERIES (SINGLE ISLAND)	140	160	---

*ALL FLOW RATES BASED ON A 7 FT. MAXIMUM FLOOR TO FRONT LOWER EDGE OF HOOD MOUNTING HEIGHT.

CITY OF NEW YORK CERTIFICATION OF APPROVAL #5517

1. REFER TO GAYLORD VENTILATOR TECHNICAL MANUAL FOR METHOD OF VERIFYING AIR VOLUMES.
2. ELECTRICAL RATING OF LIGHT FIXTURES; 120 VOLT, 60HZ, OR 220 VOLT 50HZ, OVERALL RATING - 12 AMPS OR LESS
3. IF HOOD IS EQUIPPED WITH ULTRAVIOLET LAMP SYSTEM, CONSULT GAYLORD VENTILATOR TECHNICAL MANUAL FOR PROPER MAINTENANCE AND SAFETY PRECAUTIONS.

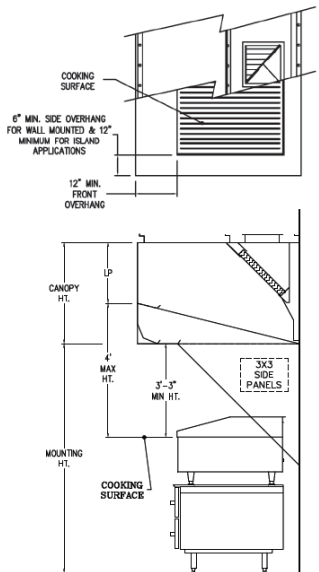

Figure 4-4-1
Ventilator Nameplate – One on Each Ventilator Section

Makeup-Air Guidelines

Capture Performance

All Gaylord Ventilators are factory engineered to operate at a specific exhaust volume, CFM (Cubic Feet per Minute), based on, primarily, the type of cooking appliance, and the exact model of the Ventilator. Capture performance is based on two primary functions, 1) the Ventilator is exhausting the engineered CFM and 2) the Makeup-Air is being introduced correctly. Makeup-Air introduced incorrectly will typically result in smoke and heat loss into the kitchen, even if the Ventilator is operating at the engineered CFM. Makeup-Air is typically brought into the kitchen space through ceiling diffusers or through a combination of Gaylord Makeup-Air Plenum Boxes, Model PBW, (refer to Figure 4-6-2) and ceiling diffusers.

Capture and Performance Guarantee

Gaylord Industries provides the following guarantee for all Gaylord Ventilators:

Gaylord Capture Performance Guarantee

Gaylord Industries warrants the Capture Performance of the Ventilator, only if the Exhaust Air Volumes are correct, per the Exhaust Volume Guidelines as stated below, and the Makeup-Air Volumes are correct and delivered correctly per the Makeup-Air Delivery Guidelines as stated below.

Exhaust Volume Guidelines

The amount of exhaust CFM through the Ventilator shall be between 100% and 110% of the values stamped on the Ventilator Nameplate for each Ventilator section.

Makeup-Air Delivery Guidelines

A. With Gaylord Plenum Boxes and ceiling diffusers.

- 1) Gaylord Plenum Boxes Model PBW shall be located immediately in front of the Ventilator, a minimum of 18" from the lower lip of the Ventilator to the discharge surface of the Plenum Box. (refer to Figures 4-6-1 and 4-6-2).
- 2) The amount of Makeup-Air delivered through the Gaylord Plenum Box(s) shall be between 90% and 100% of the values shown on Gaylord Submittal Drawings.
- 3) The amount of Makeup-Air through the Plenum Boxes shall not exceed 70% of the exhaust volume of the Ventilator.
- 4) Ceiling diffusers shall be at least 6'-0" away from all sides of the Ventilator and the outlet velocity at the diffusers shall not exceed 150 Feet per Minute (FPM).

B. With ceiling diffusers only.

- 1) Ceiling diffusers shall be at least 15'-0" away from all sides of the Ventilator and the outlet velocity at the diffusers shall not exceed 300 Feet per Minute (FPM) (Refer to Figure 4-6-1).

C. Additional Requirements.

- 1) The maximum velocity of the Makeup-Air from diffusers, transfer air diffusers, or any other type of diffusers shall not be greater than 75 FPM on all open sides of the lower edge of the Ventilator.
- 2) Cross drafts from pass through windows, hallways, or other openings shall not exceed 50 FPM.
- 3) All forms of Makeup-Air, such as ceiling diffusers, transfer air diffusers, and Plenum Boxes must be evenly distributed around each Ventilator to prevent unequal pressurization.
- 4) Kitchen pressurization shall not exceed - 0.02" W.G. relative to the dining or adjacent spaces as stated in NFPA-96 and ASHRAE Standard 154.
- 5) For more information on acceptable methods of Makeup air delivery reference ASHRAE Standard 154.

Makeup-Air Guidelines – Cont.

Following these guidelines will result in proper capture and containment at the Ventilator and enact the Gaylord Capture Performance Guarantee. If jobsite conditions cannot accommodate these guidelines, consult Gaylord Industries for alternative design.

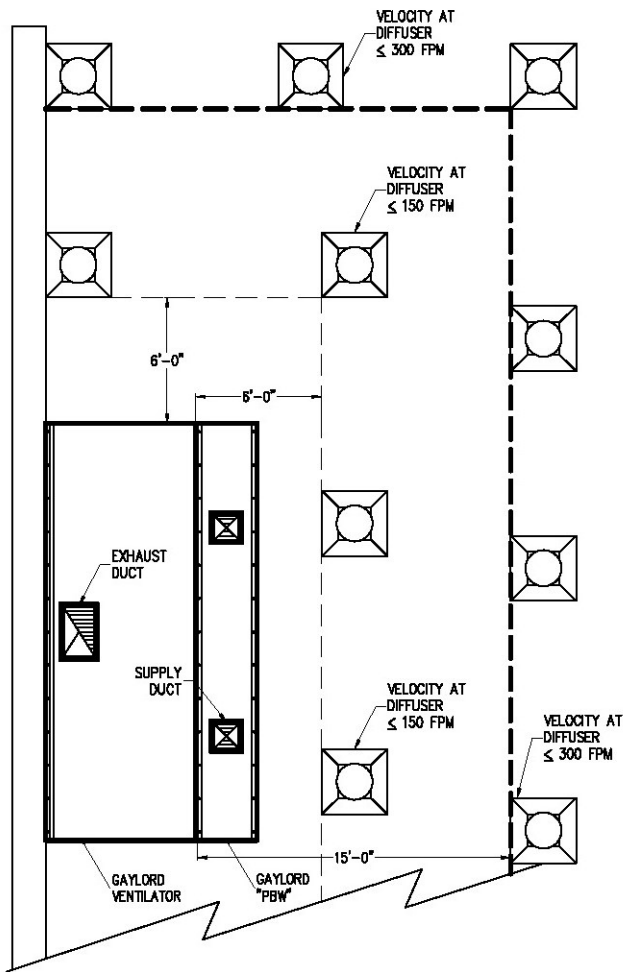

Figure 4-6-1
Plan View – Typical Kitchen

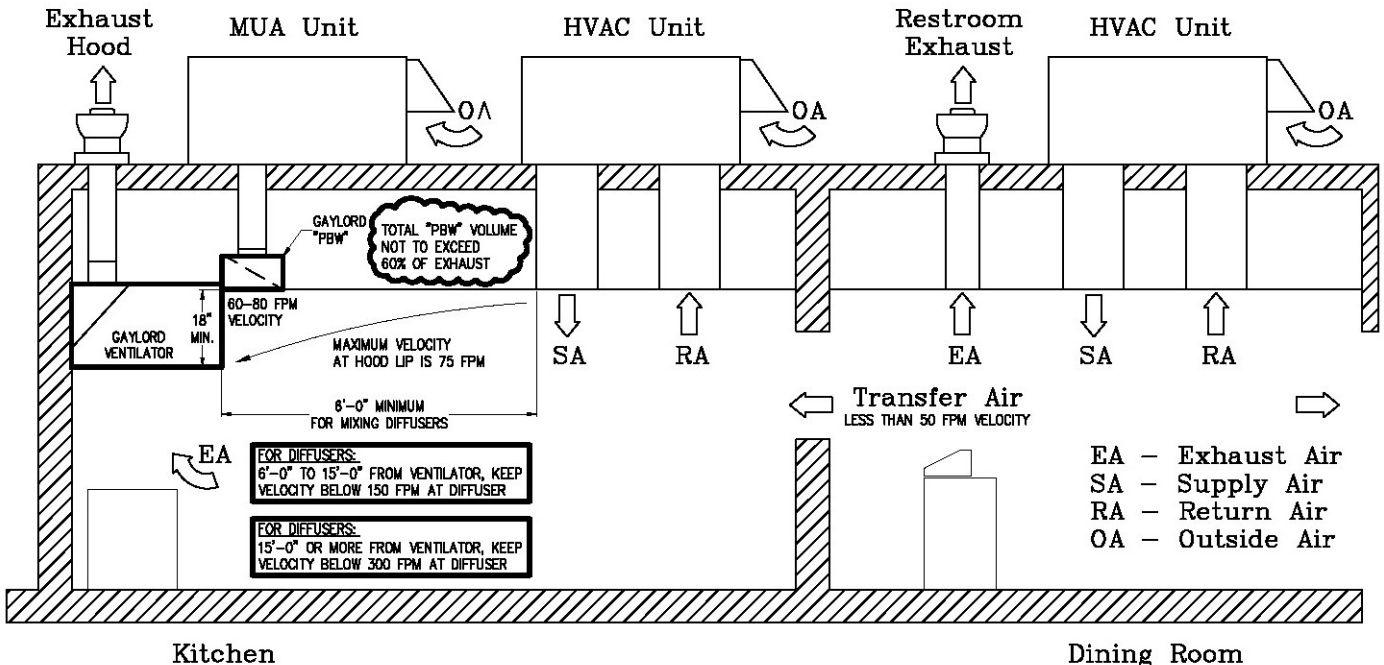

Figure 4-6-2
Section View – Typical Kitchen

Balancing Dampers

Balancing Dampers Overview

The EL Series Ventilators, as a standard, come with a Listed Slide Gate Damper model SD as shown in Figure 4-7-1. As an option the Ventilator may include one of two other models of Gaylord Industries Listed Balancing Dampers models GBD, GEBD as shown in Figures 4-8-1 and 4-8-2. If the Ventilator includes a Balancing Damper the suffix SD, GBD, or GEBD will be included in the Ventilator model number shown on the Ventilator Nameplate. Refer to Figure 4-4-1 for an example of the nameplate. In some cases the Ventilator will not include a Balancing Damper which is designated in the model number by the suffix ND.

Balancing Dampers would typically be used when two or more Ventilators are connected to a common exhaust fan. The purpose of the Balancing Damper is to raise or lower the airflow of each Ventilator to achieve the desired exhaust rate.

Balancing Damper Options

The three damper models available are as follows:

1. Model SD (Slide Damper) is located in the plenum at the entrance to the duct collar (Refer to Figure 4-7-1). The damper is a two piece system that slide across the duct opening to increase or decrease to opening size. Adjustment is made by removing the filter/ Extractor under the exhaust duct collar and reaching up with a wrench, loosen the set nuts and sliding the damper plates to the desired position. After confirming the airflow tighten the set nuts.

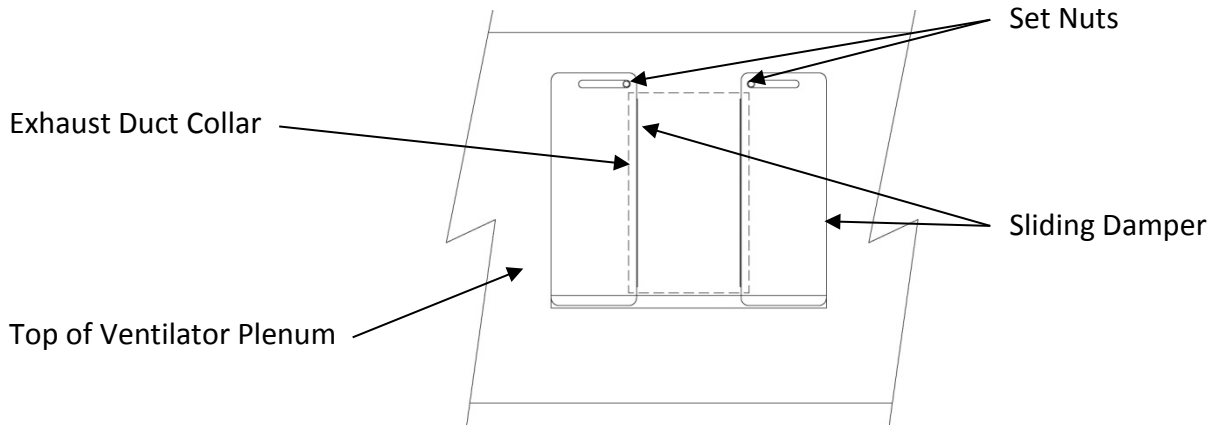

Figure 4-7-1
Plan view of Sliding Damper

Balancing Dampers – Cont.

- 2. Model GBD (Gaylord Balancing Damper) is a manually adjusted blade type balancing damper with internal setting (Refer to Figure 4-8-1). Adjustment is made by removing the filter/ Extractor under the exhaust duct collar and reaching up with a wrench to the Adjusting Nut. The nut is loosened, dampers manually adjusted to the desired position and the Adjusting Nut retightened. The distance between the damper blades, at the top, is called the Damper Set Distance, DSD. Refer to Page 4-9 and Figure 4-9-1 for additional guidance on setting the setting.

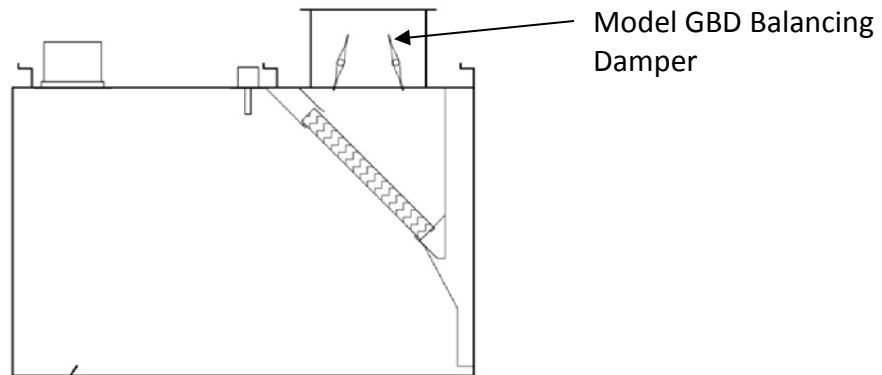

Figure 4-8-1
Typical Section with Model GBD Damper

- 3. Model GEBD (Gaylord Electric Balancing Damper) is an electrically adjusted blade type balancing damper (Refer to Figure 4-8-2). Adjustment is made by use of a potentiometer, one for each damper, mounted in a junction box near the Ventilator (Refer to Figure 4-8-3). The distance between the damper blades, at the top, is called the Damper Set Distance, DSD. Refer to Page 4-9 and Figure 4-9-1 for additional guidance on setting the setting. The GEBD is set up to automatically close upon shutting off the exhaust fan. This feature prevents conditioned air from exiting the building through the Ventilator. In the event of a power failure the damper will automatically open.

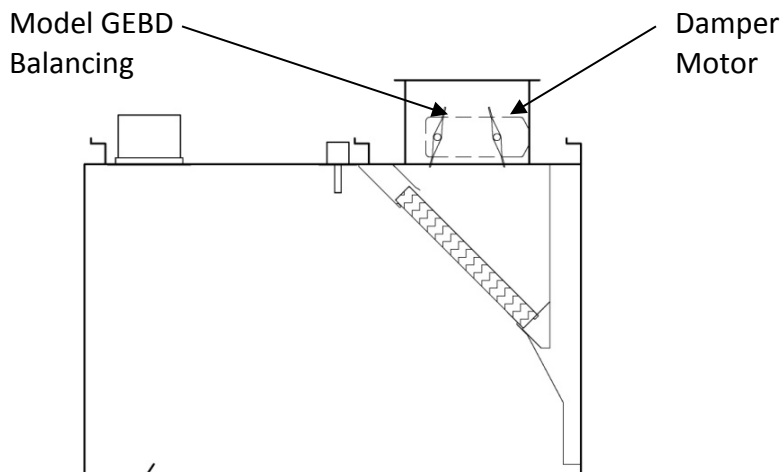

Figure 4-8-2
Typical Section with Model GEBD Damper

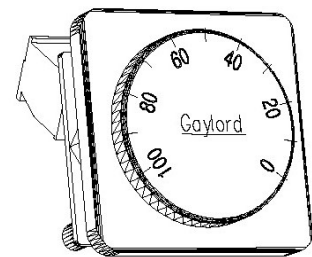

Figure 4-8-3
Potentiometer

Balancing Dampers – Cont.

When adjusting the Balancing Dampers, either Model GBD or GEBD, it may be helpful to know the % of open area. The distance between the damper blades is as shown in Figure 4-9-1 is called the Damper Set Dimension. Measure the DSD and use Table T-9-7-1 to determine the % open.

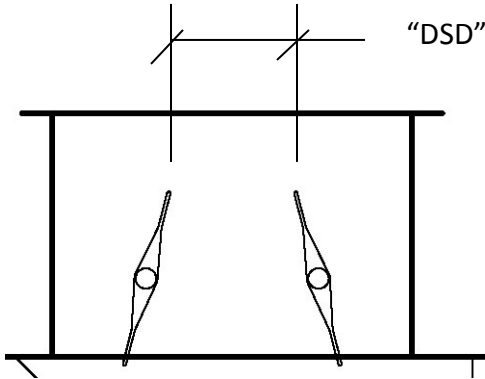

Figure 4-9-1
Typical Model GBD or GEBD
Balancing Damper

(%) OPEN	DSD (in)
100	4-1/16
90	3-7/8
80	2-15/16
70	2-1/8
60	1-1/2
50	15/16
40	3/8

Table T-4-9-1
DSD Dimension to % Open
Table

This Page Intentionally Left Blank

Replacement Parts**Table T-5-1**

PC #	Description	Gaylord Part #	Illustration
1	Baffle filters – Aluminum	16526	
2	Baffle Filters – Stainless Steel	16621	
3	Gaylord XGS Extractor	76042	
4	Extractor Removal Tool	76046	
5	Grease Drawer with Handle- (no rear wall)	76072	
6	Grease Drawer Handle	10307	
7	Globe Light (Globe)	10119	

Replacement Parts – Cont.**Table T-5-2-1**

	Description	Gaylord Part #	Illustration
1	12 x 12 Recessed Incandescent Light Lens and Retainer	13211	
2	36" Long Recessed Fluorescent Light Lens and Retainer	10111	
3	48" Long Recessed Fluorescent Light Lens and Retainer	10112	
4	LED Lamp for 36" Recessed Lights	20326	
5	LED Lamp for 48" Recessed Lights	20327	
6	Damper Control Motor 24 Volts. For GEBD Model Dampers	19176	
7	Autostart Sensor (T-Stat)	76004	
8	Autostart Controller complete with box	20317	
9	Autostart Controller only. (No box provided)	20318	

Wiring Diagrams

The Wiring Diagrams on the following pages are typical for various applications and may not represent your installation. Always refer to the Gaylord submittal drawings for the actual Wiring Diagrams for your installation.

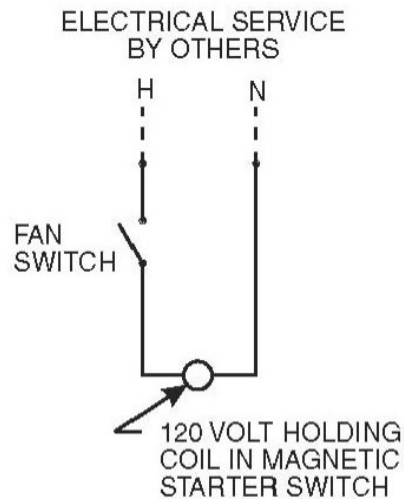

Figure 6-1-1
Typical Exhaust Fan
Switch Wiring

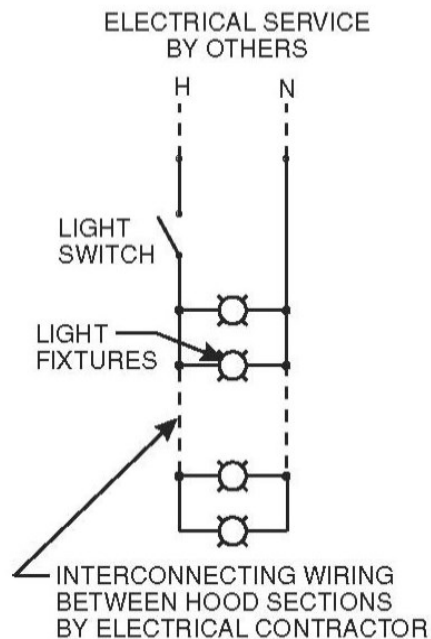
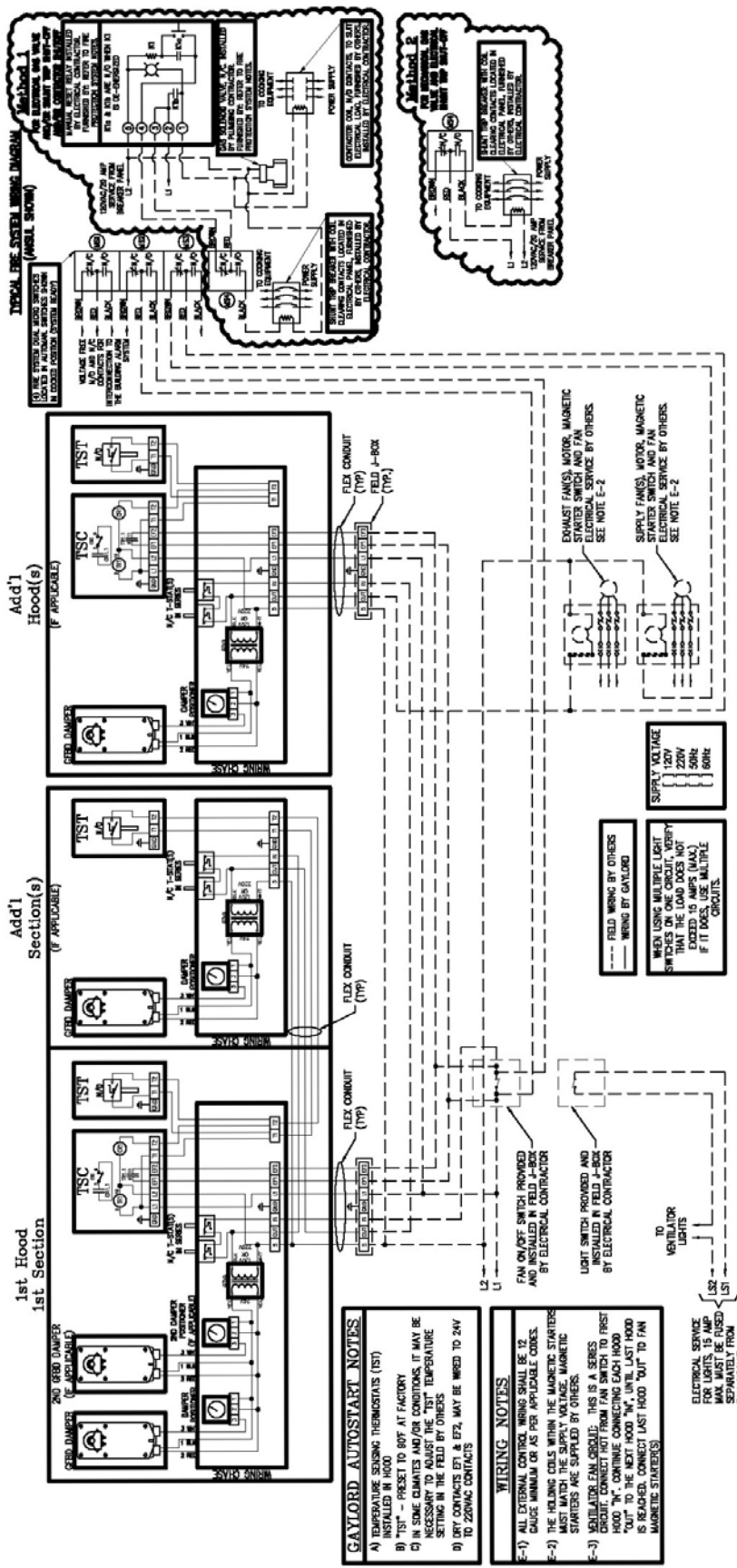

Figure 6-1-2
Typical Light Fixture Wiring

Wiring Diagrams – Cont.

Figure 6-3-1
Typical Diagram for Ventilator with
GEBD Damper and Autostart



This Page Intentionally Left Blank

Installation Requirements

Code Compliance

Ventilators must be installed to comply with all applicable codes.

1. Ventilator must be installed in accordance with NFPA-96, Standard for Ventilation Control and Fire Protection Commercial Cooking Operations, the IMC, International Mechanical Code, and all other local applicable codes.
2. All plumbing and electrical must comply the applicable codes.
3. Contractors must review applicable codes with code authorities before approving drawings for fabrication
4. Special attention must be given to code regulations relative to clearances from surrounding combustible construction (walls, ceilings, etc.).

Permits

IMPORTANT NOTE: Most building departments require the Ventilator (hood) permit separate from any other general building permit. In addition, if a Fire Extinguishing System is involved a separate permit from the Ventilator permit is typically required. The Ventilator permit is typically obtained through the plan review department and the Fire Extinguishing System permit through the fire prevention bureau. The installing contractor must check with local building departments for their requirements, and to obtain necessary permits.

Ventilator Listing

The Gaylord Model EL Series Ventilators are listed to UL 710 and Recognized by ETL. Any modification made to the Ventilator at the jobsite will void the listing.

Hanging the Ventilator

Use the following guidelines for hanging the Gaylord Ventilator:

1. The maximum section length of a Gaylord Ventilator is 16'-0". Ventilators longer than 16'- 0" are made up of multiple sections.
2. The weight of the Ventilator is shown on the Gaylord Submittal Drawings.
3. Each Ventilator section has a full length Rear Mounting Bracket at the rear for bolting to the wall and /or hanging from the overhead. There are two other full length hanging brackets; the Middle Mounting Bracket and the Front Mounting Bracket for hanging from the overhead (refer to Figure A-2-1). All three Hanging Brackets have pre-punched holes for hanging from the overhead. Hanging rods to be supplied by the Ventilator installer. If the rear bracket is used for bolting to the wall the holes must be drilled by the installing contractor at a support point in the wall. .
4. It is recommended that the number of hanging rods used be no less than the recommend minimum as shown on Table T-A-2-1.
5. The Ventilator(s) must be installed at the distance from the finish floor and the minimum side overhang dimension from the end of the Ventilator to the cooking equipment as shown on the Gaylord Submittal Drawings.
6. When there is a continuous Ventilator made up of two or more sections it is recommended that each Ventilator section is hung individually. Angles are provided at the top of the sections for bolting together. The bolts are provided by Gaylord. Hem strips and bolts are provided by Gaylord for joining the Ventilators on the underside where visible.

Installation Requirements

Table T-A-2-1

Recommend Minimum Mounting Devices					
Rear Mounting Bracket, Bolting to Wall or Hanging With Rods		Middle Mounting Bracket Hanging Rods		Front Mounting Bracket Hanging Rods	
Max. Distance From End of Ventilator Section	Max. Spacing Between Supports	Max. Distance From End of Ventilator Section	Max. Spacing Between Supports	Max. Distance From End of Ventilator Section	Max. Spacing Between Supports
12"	72"	36"	72"	12"	72"

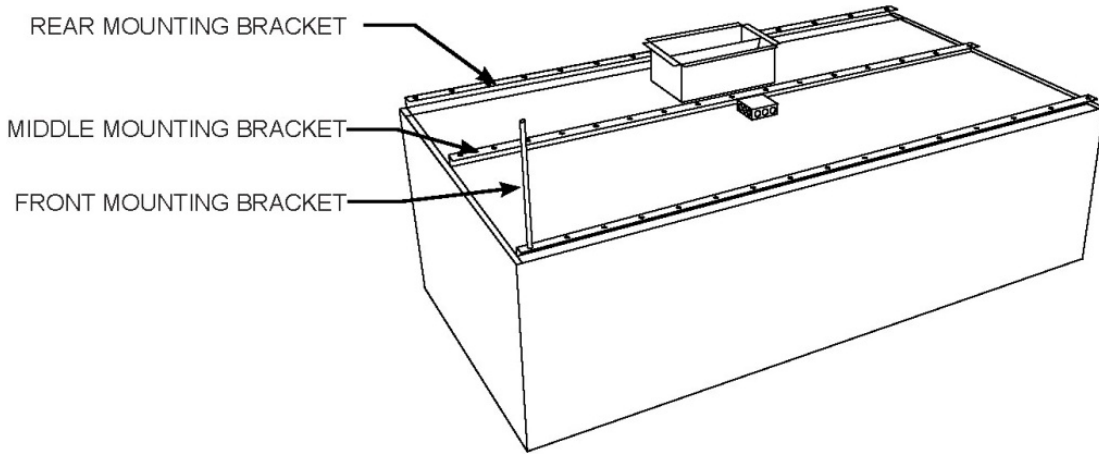

Figure A-2-1
Typical Mounting Brackets

Installation

Ductwork

Grease exhaust ducts must be installed in compliance with NFPA-96, IMC and other applicable codes. Use the following guidelines when installing the exhaust ducts:

1. Exhaust ducts must be constructed of 16 gauge steel or 18 gauge stainless steel.
2. Exhaust ducts must be constructed with continuous external welds and be grease and water tight.
3. Exhaust duct must be continuously welded to the Ventilator duct collar.
4. All elbows should be sweeping 90's. Right angle turns or elbows less than sweeping may negatively impact the operation of the Ventilator.
5. All horizontal ducts should slope towards the Ventilator and/or towards an approved sump. Amount of slope must be in accordance with the IMC.

Electrical

Refer to the wiring diagrams on the Gaylord Submittal Drawings for specific wiring interconnections.

1. If Ventilator is provided with a built-in fan switch, provide a separate 120 volt or 220 volt circuit to the fan switch J-box mounted on top of the Ventilator. The fan switch is rated for 20 amps, 277 volts, 1 h.p.at 120 volts, 2 hp at 220 volts, 16 amps max.
2. If the Ventilator is built in multiple sections, and if they contain electric dampers, or Autostart sensors, reconnect the flex conduit provided at the section breaks. The electrical contractor is responsible for making these connections.
3. If the Ventilator is provided with light fixtures, provide a separate 120 volt lighting circuit to one of the light J-box on the top of the Ventilator. Ventilator may be equipped with built-in light switch.
4. Ventilators built in multiple sections have a flex conduit at the section breaks for interconnecting the light fixture J-boxes. The electrical contractor is responsible for making these connections.

Airflow Rates

The exhaust air flow rate (and supply if part of the Ventilator) must be set at the rate stamped on the Ventilator nameplate. The exhaust volumes (and supply when provided) were established under controlled laboratory conditions and greater exhaust and/or lesser supply may be required for complete grease, smoke and vapor removal in specific situations.

Fire Extinguishing System

NFPA-96 requires a Fire Extinguishing System in all Ventilators that cover grease producing cooking equipment. In many cases the Fire Extinguishing System is pre-piped by Gaylord Industries in the factory with completion of the system by a local Fire System contractor. If not pre-piped then the entire system would be installed by a local Fire System contractor. Use the following guidelines:

1. Fire Extinguishing System furnished must be in accordance with the terms of its listing and the applicable NFPA or IFC codes and standards.
2. **Caution:** Fire extinguishing system piping installed on the Ventilator at job site should be coordinated with Gaylord Industries to ensure piping does not interfere with the Ventilator's operation and performance. Improper installation may void Listings of the Ventilator.
3. **Important Note:** NFPA-96 requires that all gas cooking equipment, and electric cooking equipment that is protected by a Surface Fire Extinguishing System must automatically shut off upon activation of the system.

Installation - Cont.

4. Most building departments require a separate Fire Extinguishing System permit from any other general building or Ventilator permit. Installing contractor to check with local building departments for their requirements, and to obtain necessary permits.

Post Installation Check List

Overview

It is recommended that the contractor responsible for the Gaylord Ventilator, complete the following **Post Installation Check List** before turning the system over to the owner of the kitchen.

Post Installation Check List

- ___ Ventilator is installed above cooking equipment as per plans.
- ___ The Ventilator exhaust volume has been measured and is within 100% and 110% of values stamped on the Ventilator Nameplate.
- ___ The Makeup-Air system is operational.
- ___ The Exhaust and Makeup-Air systems have been balanced by a certified air balancing company.
- ___ The Ventilator lights are wired and operational.
- ___ All required electrical connections between the fan circuit and the Ventilator, Building Management Systems, Remote Monitoring Systems, and the Fire Extinguishing Systems are completed per plans, and are operational.
- ___ Ventilators built in multiple sections are inter-wired.
- ___ The Baffle Filters or Gaylord XGS Extractors are installed in the Ventilator.
- ___ Fire Extinguishing System is installed and certified.

This Page Intentionally Left Blank

Limited Warranty For Model EL Series Ventilators Effective January 1, 2013

The Gaylord Ventilator and component parts furnished with the Gaylord Ventilator are warranted to be free from defects of material and workmanship under normal use when installed, operated and serviced in accordance with factory recommendation.

The Manufacturer's obligation under this warranty and any warranties implied by law shall be limited to repairing or replacing at its option any part of said equipment when either Gaylord Industries, or the Licensed Gaylord Manufacturer's examination shall disclose to its satisfaction to be thus defective, for a period of one (1) year from the date of beneficial use, or eighteen months from date of shipment, whichever occurs first, provided proper and acceptable evidence of such is recorded at the factory. GAYLORD INDUSTRIES AND THE LICENSED GAYLORD MANUFACTURER SHALL NOT BE RESPONSIBLE FOR INCIDENTAL OR CONSEQUENTIAL DAMAGES RESULTING FROM A BREACH OF THIS WARRANTY.

In the United States, the labor required to make repairs and replacements under this warranty shall be furnished by Gaylord Industries or the Licensed Gaylord Manufacturer or its authorized representative. Such labor shall only be provided Mondays through Fridays during the hours between 8 a.m. and 4 p.m. Requests for repairs or replacement parts should be made to GAYLORD INDUSTRIES, 10900 SW AVERY STREET, TUALATIN, OR 97062, USA. Phone 503-691-2010 or 800-547-9696.

Outside the United States, all replacement parts furnished under this warranty shall be F.O.B. Gaylord Industries, Tualatin, Oregon U.S.A. The owner shall pay the necessary freight delivery charges, and necessary labor for removal and installation of parts, and any tariffs, duties or all taxes.

Component parts not manufactured by Gaylord Industries such as electrical switches, relays, solenoid coils, etc., shall be warranted under the terms and conditions of the warranty that is published by the manufacturer of said component parts.

This warranty does not cover routine maintenance and inspection of the cleaning system as spelled out in The Gaylord Ventilator Technical Manual. This warranty also does not cover malfunctions or improper operation caused by fluctuating electrical power or power surges.

This is the sole warranty with respect to the aforesaid items. NEITHER GAYLORD INDUSTRIES OR THE GAYLORD LICENSED MANUFACTURER OR ANY OTHER PARTY MAKES ANY OTHER WARRANTY OF ANY KIND WHATSOEVER, EXPRESSED OR IMPLIED, AND ALL IMPLIED WARRANTIES OF MERCHANTABILITY AND FITNESS FOR A PARTICULAR PURPOSE WHICH EXCEED THE AFORESAID OBLIGATIONS ARE HEREBY DISCLAIMED AND EXCLUDED FROM THIS AGREEMENT.

Service and Warranty Policies

1. No warranty work shall be performed on the product without a Purchase Order from Gaylord Industries, if financial reimbursement is to be requested.
2. No warranty shall be provided on equipment that has been started up and in operation for more the 90 days unless, a product maintenance schedule has been created and performed per the requirements of this technical manual.
3. Any, and all, wearable parts are not to be considered warranty items, regardless of installation date, unless previously authorized by the factory.

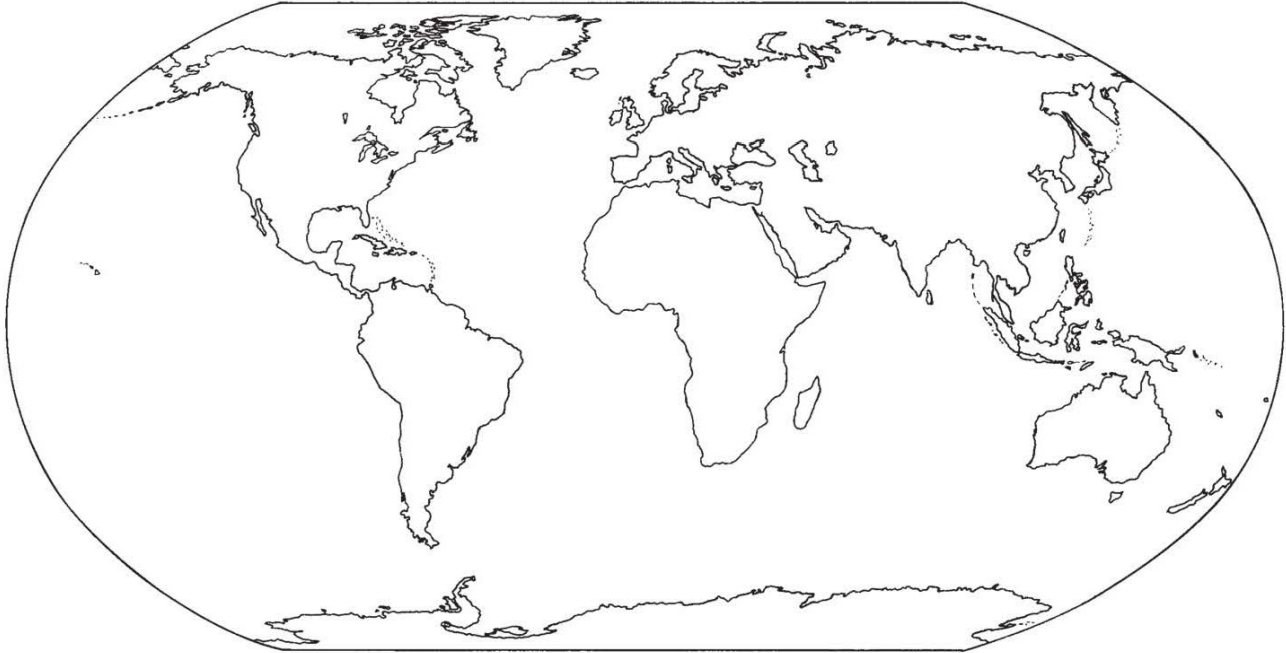

**WORLDWIDE SALES, MANUFACTURING AND SERVICE
FOR THE NAME AND LOCATION OF THE NEAREST
CERTIFIED SERVICE AGENCY, VISIT OUR WEB SITE:**

www.gaylordventilation.com

OR CONTACT US AT:

GAYLORD INDUSTRIES

10900 S.W. AVERY STREET
TUALATIN, OREGON 97062 U.S.A

email: info@gaylordventilation.com

Phone: 503-691-2010

800-547-9696

Fax: 503-692-6048

LOCAL SERVICE AGENCY