

[CAF16DAC]

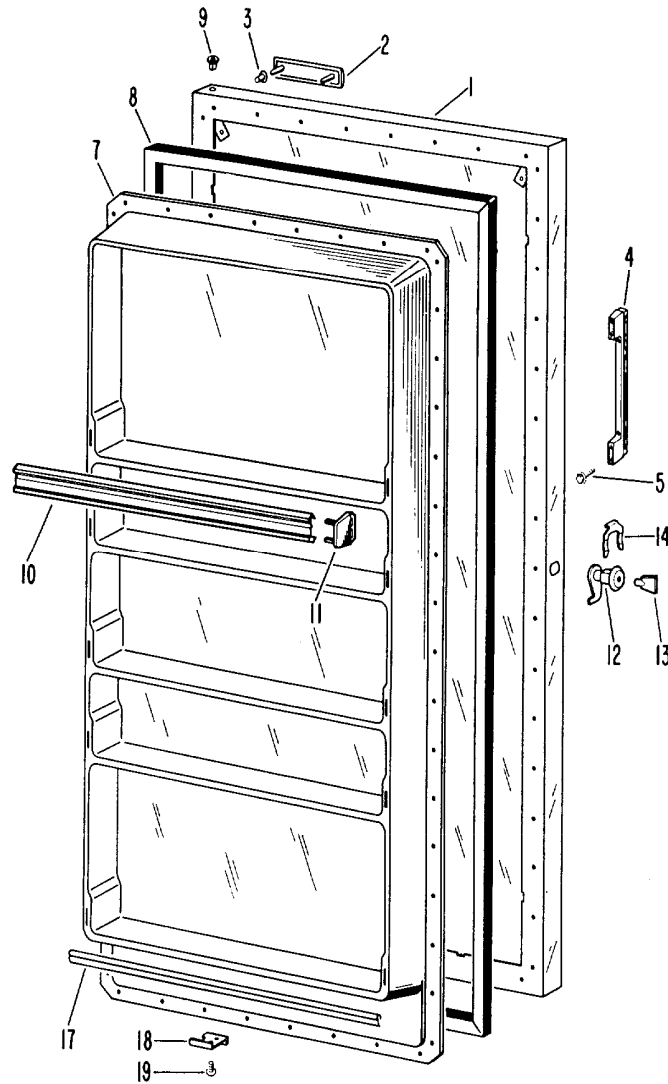

(Art No. WR15465)

REF. NO.	CAT.NO.	NO. REQ.	DESCRIPTION	REF. NO.	CAT.NO.	NO. REQ.	DESCRIPTION
1	WR78X6786		O.D. Panel RH (WH)	9	WR13X5102	5	Bushing Door (For Hinge) Top&Btm
	WR2X5385	2	Brkt. Wire (Btm. of Door)	10	WR17X5920	5	Shelf Front
	WR1X5101	2	Screw Brkt.	11	WR2X6053	5	End Cap Shelf Front-R/Side
	WR1X5115	2	Washer Screw		WR2X6052	5	End Cap Shelf Front-L/Side
2	WR3X396		Nameplate	12	WR5X5032		Lock Asm.
3	WR2X3757	2	Fastener Nameplate	13	WR5X65		Key
4	WR12X439		Handle Door	14	WR5X66		Clip Lock
	WR1X1530		Washer	17	WR14X5097		Gasket I.D. Panel
5	WZ6X112	2	Screw Handle		WR1X5406	5	Rivet Gasket to Door
7	WR77X5504		I.D. Panel	18	WR2X5637		Door Stop
	WR1X5179	22	Screw I.D. Panel		WR13X5013		Reinforcement Door Stop
	WR1X5405	24	Screw I.D. Panel Corners	19	WR1X5485		Screw Stop
8	WR24X5135		Gasket				

[CAF16DAC]

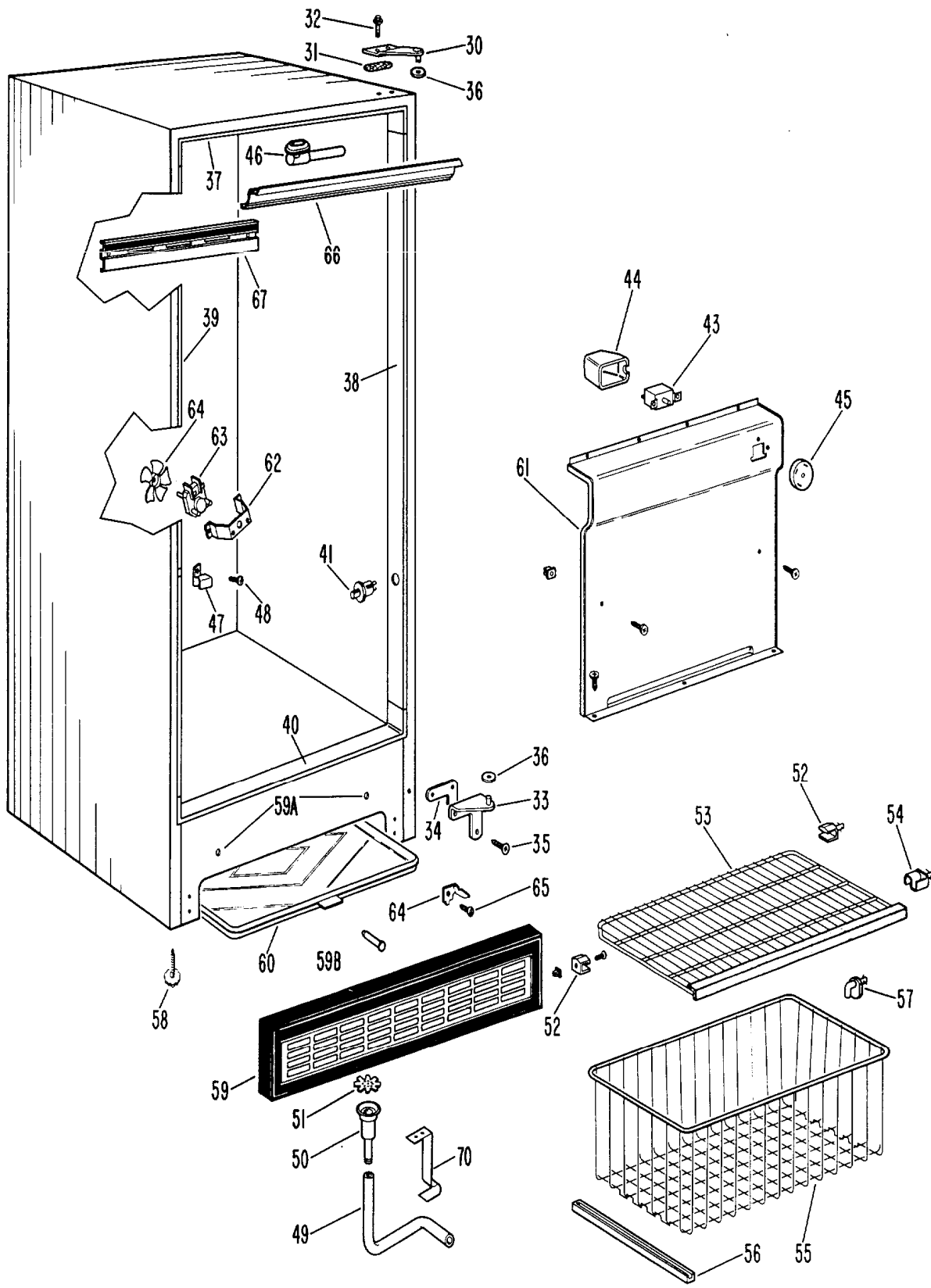

[CAF16DAC]

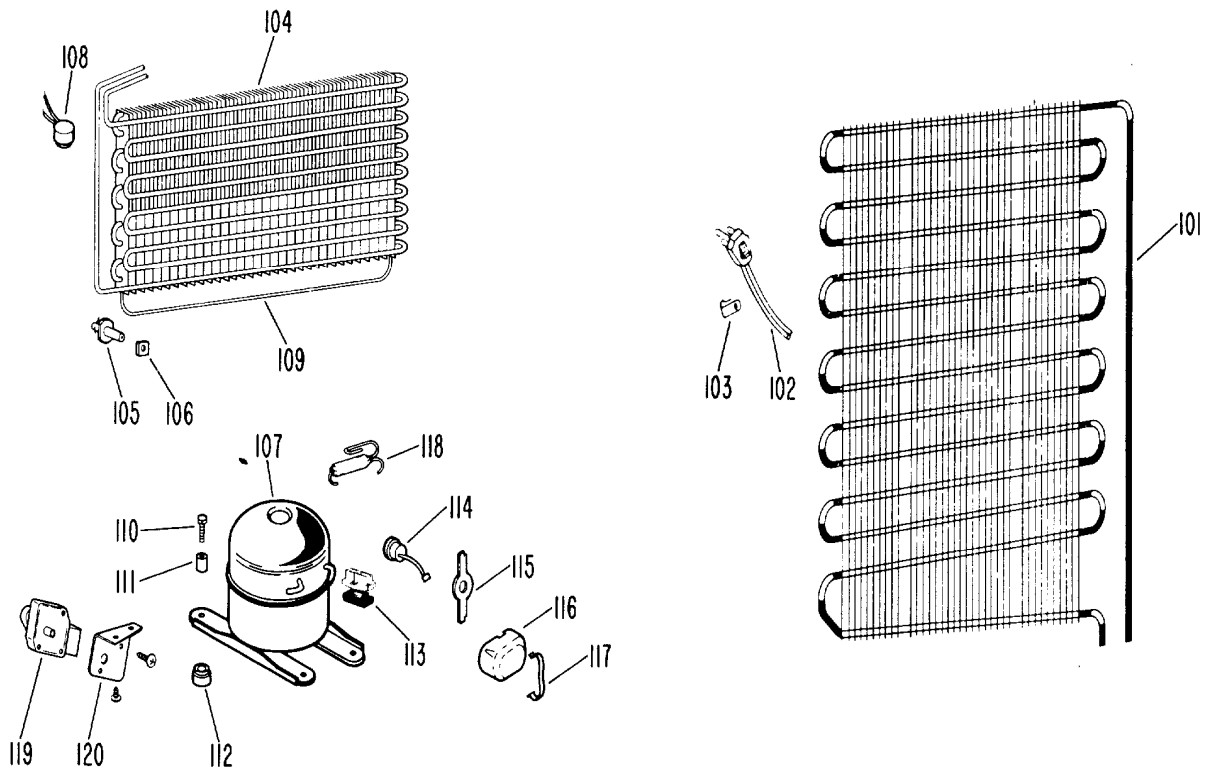

(Art No. WR14438)

REF. NO.	CAT.NO.	NO. REQ.	DESCRIPTION	REF. NO.	CAT.NO.	NO. REQ.	DESCRIPTION
101	WR84X5007		External Condenser	111	WR2X5642	3	Sleeve Screw
102	WR23X108		Power Cord	112	WR1X5134	4	Grommet Compressor Mtg.
103	WR1X5278		Strain Relief Cord	113	WR7X135		Relay
104	WR85X5204		Evaporator Asm.	114	WR8X58		Guardette
	WR97X156		Freon Charge 9 oz.	115	WR2X5641		Spring Guardette
105	WR2X6206	2	Support Evap.	116	WR13X5103		Cover Relay & Guardette
106	WR2X6207	2	Spacer	117	WR1X5119		Clip Cover
107	WR87X5083		Hi-Side	118	WR86X2		Drier
	WR97X105		Freon Charge 9-1/2 oz.	119	WR9X5127		Defrost Timer
108	WR50X5032		Defrost Thermostat		WZ5X160	2	Screw Timer to Brkt.
109	WR51X5186		Defrost Heater	120	WR2X6209		Bracket
	WR2X6208	2	Clip Heater to Coil		WR1X5450		Screw Brkt.
110	WR1X5060	3	Screw Compressor Mtg.		49-6293		Use & Care Book