

Giorik Electric Combination Ovens

Series: SEHE, SEHG, SETE, SETG Operation Manual





COMBI OVEN OPERATION MANUAL

DEAR CUSTOMER

Congratulations on the purchase of your new Combination Oven. By purchasing this new oven, you have entered into a new era of cooking. With the new technology and simplicity built into the Giorik Combination Oven, you will receive excellent results in no time at all. The oven's ease and simplicity of operation will help you realize savings in training dollars.

With the Giorik one touch, simply identify the relevant food, push start, and you are cooking. The simplicity of operation guarantees consistently produced products without having to set times, temperatures, and finishes.

For the Chef, the Combination oven offers a wide array of functions and steps that once tested can be saved and recreated by experienced kitchen staff as well as the first time operator.

NOTICE

Please read the operations manual in full before starting up the appliance to make sure all the benefits and safety information is understood.

For more information, culinary support, and customer service please contact 1-864-315-1615

Appliance Model _____

S/N _____

Dealer _____

Installer _____

Date of Install _____

TABLE OF CONTENTS

INTRODUCTION	5
INTENDED USE.....	5
SAFETY INFORMATION	5
SAFETY PRECAUTIONS.....	5
SAFETY SIGNS AND MESSAGES.....	5
SAFE WORK PRACTICES.....	6
SPECIFIC PRECAUTIONS.....	7
GENERAL SAFETY GUIDELINES FOR INSTALLERS, USERS, AND SERVICE TECHNICIANS.....	8
HEALTH AND SANITATION PRACTICES	9
WATER QUALITY	10
PRODUCT OVERVIEW	11
OPERATION	12
OVEN COMMISSIONING AND TESTING.....	12
CONTROL PANEL.....	12
PICTOGRAMS KEY.....	13
RECIPE SCREEN BY PRODUCT TYPE.....	13
MANUAL COOKING SCREEN.....	14
HOME SCREEN.....	15
HOW TO INTERACT WITH THE TOUCH-SCREEN.....	15
MANUAL COOKING MODE.....	15
COOKING MODES: CONVECTION, MIXED AND STEAM.....	16
HOLD MODE.....	18
SMOKING MODE.....	18
STARTING AND STOPPING COOKING.....	19
CUSTOMIZED COOKING PROGRAMS.....	19
CREATING A COOKING PROGRAM.....	20
SAVING A COOKING PROGRAM.....	21
MODIFYING A COOKING PROGRAM.....	22
COPY, MOVE, RENAME AND DELETE.....	22
SELECTING A PROGRAM FROM THE MENU.....	23
THE RECIPETUNER INTERFACES.....	24
RACK CONTROL SERVICE MODE.....	24
USING THE RACK CONTROL FUNCTION.....	25
CREATING A NEW RACKCONTROL PROGRAM.....	27

TABLE OF CONTENTS (continued)

USING THE EASYSERVICE FUNCTION IN RACKCONTROL	28
THE REGENERATION FUNCTION	29
REGENERATION PROGRAMS	30
THE CORE PROBE AND COOKING IN ΔT	30
RECOMMENDATIONS FOR COOKING	31
COOKING ADVICE: COOKING UNIFORMITY	31
RECOMMENDATIONS FOR COOKING-VACUUM COOKING AND PASTEURIZATION	31
RECOMMENDATIONS FOR COOKING-HYDRATION OF THE STEAM	32
FUNCTIONS MENU	32
WASHING	32
COOLING	33
SERVICE	34
CONFIGURATION	34
BOILER CLEANING	35
LOG DISPLAY	35
ADVANCED SERVICES	35
MAINTENANCE AND CLEANING	37
PRODUCT OVERVIEW	38
WARRANTY	40

INTRODUCTION/SAFETY INFORMATION

Intended Use

Giorik Combination Ovens are solely intended for use in commercial kitchens.

The units may only be used for cooking food using the correct racks, containers, baking sheets, and slide in pans. Roll in rack dollies and cassettes must only be supplied by Giorik.

Units should only be used with purest quality drinking water for unit protection. The owner of the oven should test water for filtration needs. Water quality needs can be found in the manual under "Water Quality."

Your new Combination oven should not be used for the following purposes, among others:

- As a dishwasher
- Drying towels, paper, or dishes
- As a storage container
- Heating brines, oils, or other chemicals
- Heating closed containers (i.e. canned goods)
- Heating flammable liquids
- Deep frying
- Cleaning air filters or equipment parts



Safety Precautions

Always follow recommended safety precautions listed in this manual. To the left is the safety alert symbol. When you see this symbol on your equipment, be alert to the potential for personal injury or property damage.

Safety Signs and Messages

The following safety signs and messages are placed in this manual to provide instructions and identify specific areas where potential hazards exist and special precautions should be taken. Know and understand the meaning of these instructions, signs, and messages.

⚠ DANGER

This message indicates an imminently hazardous situation which, if not avoided, will result in death or serious injury.

⚠ WARNING

This message indicates a potentially hazardous situation, which, if not avoided, could result in death or serious injury.

⚠ CAUTION

This message indicates a potentially hazardous situation, which, if not avoided, may result in minor or moderate injury. It may also be used to alert against unsafe practices.

NOTICE

This message is used when special information, instructions or identification are required relating to procedures, equipment, tools, capacities and other special data.

⚠ WARNING

California Residents Only

WARNING: This product can expose you to chemicals including chromium which is known to the State of California to cause cancer and birth defects or other reproductive harm. For more information go to www.P65Warnings.ca.gov.

SAFETY INFORMATION—SAFE WORK PRACTICES

Beware of High Voltage

This equipment uses high voltage. Serious injury can occur if you or any untrained or unauthorized person installs, services, or repairs this equipment. ALWAYS use an AUTHORIZED SERVICE AGENT to service your equipment.



Beware of Hot Surfaces—DO NOT Touch

The door on this unit reaches temperatures that can cause burns. Use caution when opening and closing the door. Do not touch any of the surfaces when the unit is heated.



Protect Children

Keep children away from this equipment. Children may not understand that this equipment is dangerous for them and others.



NEVER allow children to play near or operate your equipment.

Be Prepared for Emergencies

Be prepared for fires, injuries, or other emergencies. Keep a first aid kit and a fire extinguisher near the equipment. You must use a 40-pound type BC fire extinguisher and keep it within 25 feet of your equipment. Keep emergency numbers for doctors, ambulance services, hospitals, and the fire department near your telephone.



Know Your Responsibilities as an Employer

- Make certain your employees know how to operate the equipment.
- Make certain your employees are aware of the safety precautions on the equipment and in this manual.
- Make certain that you have thoroughly trained your employees about operating the equipment safely.
- Make certain the equipment is in proper working condition. If you make unauthorized modifications to the equipment, you will reduce the function and safety of the equipment as well as void the warranty.

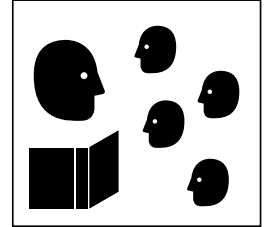

Keep this Manual With the Equipment

This manual is an important part of your equipment. Always keep it nearby for easy access.

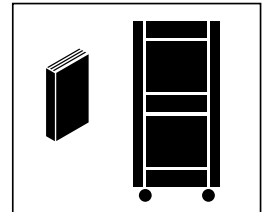

If you need to replace this manual, contact:

Giorik US

Technical Services
128 Millport Circle, Suite 200
Greenville, SC 29607

Or call toll free: 1-864-315-1615

Or visit www.giorikus.com

SAFETY INFORMATION—SPECIFIC PRECAUTIONS

⚠ CAUTION

Equipotential Ground Plane

When a high current flows through a conductor, differences in potential appear between the conductor and nearby metallic surfaces near the appliance. As a result, sparks may be produced between the appliance and surrounding metal surfaces. These sparks could cause serious injury, damage, or fire.

Giorik provides an Equipotential ground terminal for the connection of a bonding conductor after the installation of the appliance per IEC60417-1. This terminal is located on the inside of the Power Entry Supply box near the Earth connection and is marked with this symbol

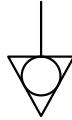

⚠ WARNING

Disconnect power before servicing.

⚠ WARNING

Improper installation, adjustment, alteration, service, or maintenance can cause property damage, injury, or death. Read the installation, operating and maintenance instructions thoroughly before installing or servicing this equipment.

⚠ WARNING

DO NOT connect Combi oven drain connection to any drain material that cannot sustain 175° F.

NOTICE

For Your Safety

DO NOT store or use gasoline or other flammable vapors or liquids in the vicinity of this or any other appliance.

NOTICE

For Your Safety

All service must be performed by a qualified Giorik authorized technician.

NOTICE

For Your Safety

This manual is a part of your new Combination oven. You must keep and maintain it for the entire life span of your Combination oven and pass it on to the next owner of the unit.

Retain this manual for reference, keep it where you can use it.

This manual may be subject to new technical developments, modifications, and unforeseen errors.

DO NOT operate or attempt to operate this appliance or any accessories without reading completely and fully understanding this manual.

SAFETY INFORMATION

General Safety Guidelines for Installers, Users, and Service Technicians

- Read, understand, and follow the instructions, and heed and obey the warnings of the Installation Manual, the Operator's Manual, and the labels on the Combi oven, accessories, and supporting products.
- Improper installation, maintenance, cleaning, or modifications to the Combi oven can lead to injury or death of the operator(s), and equipment and property damage.
- **Steam** – To avoid steam burns, open the Combi door by turning the handle to the left or clockwise ("airing") position and waiting for the steam and condensate to clear. Then, turn to the right or counterclockwise and slowly open the door. Never breathe steam, superheated steam, or hot air.
NOTE: The cooking program is interrupted whenever the door is opened.
- **Heat** – The Combi, cooking containers, shelves, and inner door and anything else inside the cooking compartment are HOT, as are many of the component parts. Wear DRY heatproof gloves or mitts.
- **Exhaust Vents** – The top of the Combi, and the gas and steam exhaust vents are very hot during operation and remain hot for some time. Never breathe gas or steam from the exhaust vents.
Use extreme caution when working on or near this area and component parts.
- **Scalds** – DO NOT place containers with liquid contents or contents that become liquid on oven racks higher than you can see. You must be able to see into the container. Cover containers (individual or on trolleys) containing hot or hot liquid items to help prevent spills during transport. Observe and heed, and obey the additional warning labels posted on the Combi.
- **Grease Spatter** – Hot grease will spatter and cause burns if sprayed with water. Locate fryers and similar appliances outside the range of the Combi hand shower.
- **Electric Shock** – Use the hand shower only on the inside of the oven. Use of the hand shower, hoses, power cleaners, or pressure washers on the outside of the Combi can cause electric shock and/or damage to electrical and electronic components.
- **Cleaning and Daily Maintenance** – Wait for the Combi to cool before cleaning and performing daily maintenance. **DO NOT** spray water in a hot cooking compartment. Do not use hoses, power cleaners, pressure washers, or harsh or abrasive cleaning agents inside OR outside the cooking compartment.
- **Cleaning Agents** – Use only Giorik approved cleaning and descaling products. Follow the instructions and heed and obey the warnings on the labels. Other products can damage the Combi, cause injury, or present health hazards.
- Wear appropriate shoes/boots to the work area to help protect feet and to help prevent slips and falls.
- Use non-slip, draining, anti-fatigue FLOOR MATS (not included) rated for use in wet, greasy, and dry work areas to help prevent slipping and / or falling injuries. Obtain the best mats for your needs from your local supplier.

HEALTH AND SANITATION PRACTICES

Giorik Combi Ovens are manufactured to comply with health regulations and are tested and certified to UL®, cUL®, and NSF® standards. You must operate the equipment properly using only quality products and use meat thermometers to insure meats are thoroughly cooked.

Food Handling

- Wash hands thoroughly in warm, soapy water after handling raw poultry or meats.
- Clean and sanitize all utensils and surfaces that have been in contact with raw products. Clean and sanitize the meat forks or baskets between cooking.
- Never place cooked meats on the same surfaces used to prepare raw meats, unless the area has been thoroughly cleaned and sanitized.

Storage of Raw Meats

- Designate an area or shelf strictly for the storage of all raw meats to be used in the oven.
- Raw product must always be stored at temperatures below 38° F. (3° C.).
- Never store or mix raw foods above cooked foods, as **this is a health hazard**. The drippings from raw foods contaminate cooked or processed foods.
- All chicken and chicken parts to be stored overnight must be thoroughly iced down and refrigerated.

Coding Cooked Foods

- All products cooked during the day should be sold the same day.

NOTE: Follow your company's procedures for the handling of any leftover product.

Storage of Prepared Foods

- Cold foods should be kept at or below 38° F. (3° C.).
- Hot foods must be maintained to meet local health codes, usually a minimum 145° F (63°).

WATER QUALITY

As with all steam related products, water filtration and regular filter replacements may be necessary with the Combi. It is strongly recommended to have a water analysis performed prior to installing the Combi. Poor water quality can have a big impact on cook quality, performance, and longevity of the Combi. Varying combinations of pH; alkalinity; hardness; chlorides; total dissolved solids; and other chemical characteristics, when subjected to high temperatures, will cause water to have a tendency to either scale or corrode.

There are a number of different water filter/treatment systems available and each has its own benefits and specialties. Below are a different styles and their benefits. Multiple styles may need to be used to get the water to proper levels.

- **Particle Filter**

When the water contains sand, iron particles, or suspended matter, we recommend a 5-15 µm (micrometer) particle filter.

- **Active Carbon Filter**

When the level of chlorine (Cl) in the water exceeds 0.5 mg/L (ppm) (information available from the water company), an active carbon filter should be installed.

- **Phosphate Additive System**

A Phosphate Additive (Feeder) System is recommended for steam generator units only when a moderate level of scale (not containing chloride) is experienced. The system recommended is Kleensteam from Everpure.

- **Ion Exchange System**

An ion exchange system is recommended for a steam generator based unit when a high level of scale (not containing chloride) is experienced and for a spritzer based unit when any scale (not containing chloride) is experienced. Systems recommended: Claris from Everpure (H+ Ion Exchanger). Sodium ion exchangers (as used in dishwashers) must not be used.

- **Blended Reverse Osmosis (RO)**

When the water has a chloride (Cl) concentration above 20 mg/L (= 20 ppm), a blended RO system should be installed to avoid corrosion.

NOTE: Make sure a minimum conductivity of 20 µS/cm (microSiemens) remains in the water for steam generator units.

Water quality must conform to the below requirements. If water does not meet the minimum quality and damage to the oven is determined to be due to water quality, it will be considered non-warranty and will not be covered under the stated warranty policy.

Minimum Water Quality Requirements

- Hardness (CaCO₃) = 30 to 90 mg/L (Milligrams per Liter)
- TDS (Total Dissolved Solids) = 40 to 150 mg/L (Milligrams per Liter)
- Free Chlorine = Less than 0.1 mg/L (Milligrams per Liter)
- Chlorides = Less than 20 mg/L (Milligrams per Liter)
- Chloramines = Less than 0.5 mg/L (Milligrams per Liter)
- Sulfates & Nitrates = Less than 20 mg/L (Milligrams per Liter)
- Total Silica = Less than 10 mg/L (Milligrams per Liter)
- Total Iron = Less than 0.1 mg/L (Milligrams per Liter)
- pH level = 7.0 to 8.5
- Langelier Index = Greater than 0.5
- Conductivity (Boiler Models only) = Minimum of 20 µS/cm (microSiemens per cm)

Water Usage

Average Water Flow = 8.5 gal/hour at 36 psi inlet pressure for half size 6 grid oven; 9.8 gal/hour at 36 psi inlet pressure for half size 10 grid oven; 11.6 gal/hour at 36 psi inlet pressure for full size 10 grid oven; Peak Water consumption = 2.6 gal/min

PRODUCT OVERVIEW

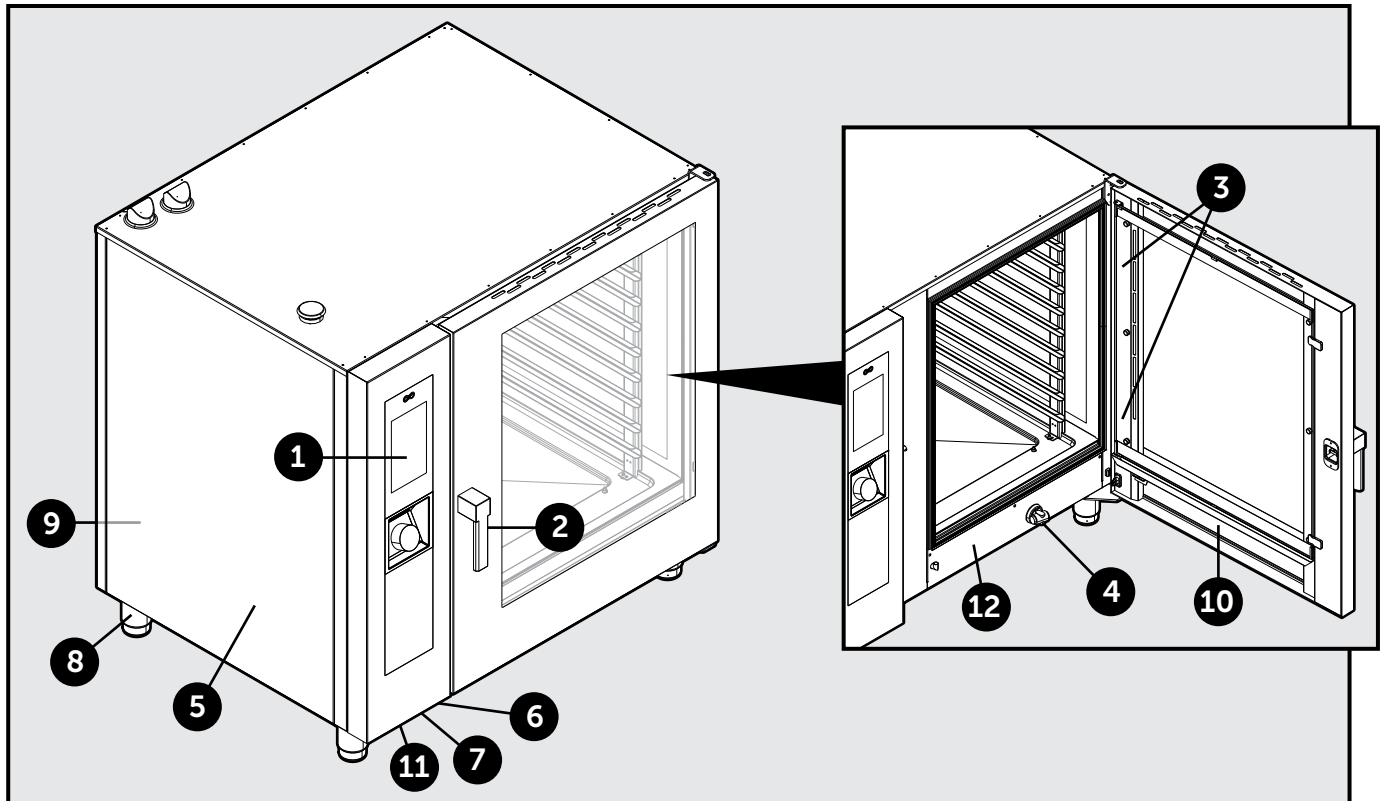

1. Control Panel

2. Door Handle (2-step)

- Left to vent position
- Right to open

3. Oven Lights

- On the door

4. Hose Reel

- Behind the door on table top units

5. Side Panel

- Removable for service access

6. USB Port

- Under control panel

7. Core Temperature Port

- Under control panel
- Removable on table top unit only

8. Legs

- 6" adjustable

9. Rating Plate (on Back Corner)

- Contains the following information:
 - Model Number
 - Serial Number
 - Voltage
 - Power Consumption
 - Amp Draw
 - Breaker Size
 - Phase
 - Frequency

10. Door Drip Tray

- Behind Door
- Built in Trolley on Floor Models

11. Control Panel Air Filter

12. Oven Drip Tray

- Below gasket or oven cavity

OPERATION

OVEN COMMISSIONING AND TESTING

Before putting the oven into operation, you should carefully carry out all the necessary checks to ascertain the conformity of the equipment and installation of the appliance as provided by law and according to the technical and safety instructions given in this manual.

The compliance of the following must also be checked:

- The temperature in the oven installation area must be greater than 39° F (4° C).
- The cooking chamber must be empty.
- All packaging must be entirely removed, including the protective film applied on the oven walls.
- The vents and air slots must be open and free of obstructions.
- Any pieces of the oven that were removed for installation must be replaced.
- The general electrical switch must be closed and the water and gas cut-off valves upstream of the appliance must be open.

CONTROL PANEL/TESTING

The oven should be tested by completing a cooking cycle to verify that the equipment works properly and without any anomalies or problems.

1. Switch the oven on by pressing the ON/OFF button.
2. Set a cooking cycle with temperature at 300° F (150° C), time set to 10 min., and humidity at 5%.

Carefully check the points given in the following list:

- The lights in the cooking chamber turn on when pressing the button and turn off automatically after 45 seconds (if they are not turned off early by pressing the button again).

- The oven fan and heating elements stop if the door is opened and starts again when the door is closed.
- The fan/s motor reverses the direction of rotation automatically; reversal takes place approximately every 3 minutes (time varies depending on the cooking time).
- For the ovens with two fans in the cooking chamber, the motors have the same direction of rotation.
- Check that the water is escaping in the direction of the fan from the humidity inlet tube in the cooking chamber.

At the end of the cooking cycle, the oven emits an audible signal.

Control Panel

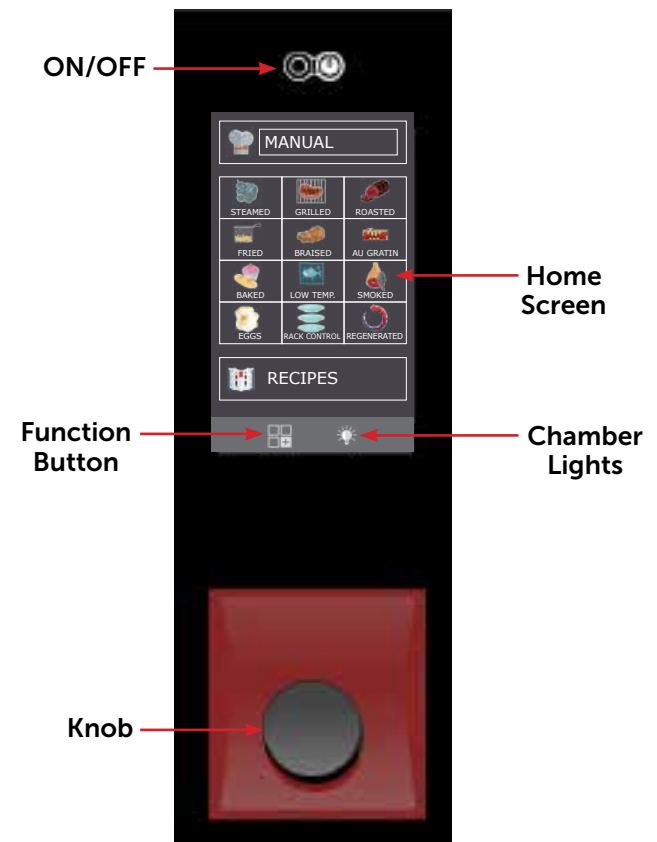

OPERATION

ICON KEY



MANUAL

Start Screen



Steamed



Grilled



Roasted



Fried and Sautéed



Braised



Au Gratin



Baked (bread & pastry)



Low Temperature



Smoked



Eggs



Rack Control



Regeneration



Recipes



FUNCTIONS



CHAMBER LIGHTS

RECIPE SCREEN BY PRODUCT TYPE



Pasta and Rice



Poultry



Meat



Fish and Seafood



Vegetables



Dessert



Bread



Extra

OPERATION

MANUAL COOKING SCREEN



Cooking Mode: Convection only*



Cooking Mode: Mixed (Steam and Convection)



Cooking Mode: Steam only*



Mode: Hold of Temperature



Automatic Cooling
(present only from phase 2)



Mode: Smoking



Time / Timer



Mode with Core Probe



Delta-T Mode



Humidity Discharge Valve: Closed



Humidity Discharge Valve: Open



Relative Humidity Percentage



SteamTuner Adjustment
(steam hydration)



Unlock Button: allows one to
change a program



Program Change Indicator (changed
by the user or new program)



During cooking allows one to verify
the SET of the program



Manual Humidifier Button



Home Button (brings one back to
the start screen)

OPERATION

HOME SCREEN

Switch the oven on by pressing the **ON/OFF BUTTON**. The home page will appear on the display.

It is possible to select whether to perform **MANUAL COOKING (A)** or use one of the pre-set programs in the **COOKING TYPE GROUPS (B)** or in the **RECIPES (C)**.

Press the **FUNCTIONS BUTTON (D)** to set washing, import and export the cooking programs and operate on the oven system settings. (Some of these functions are reserved exclusively to specialized technicians.)

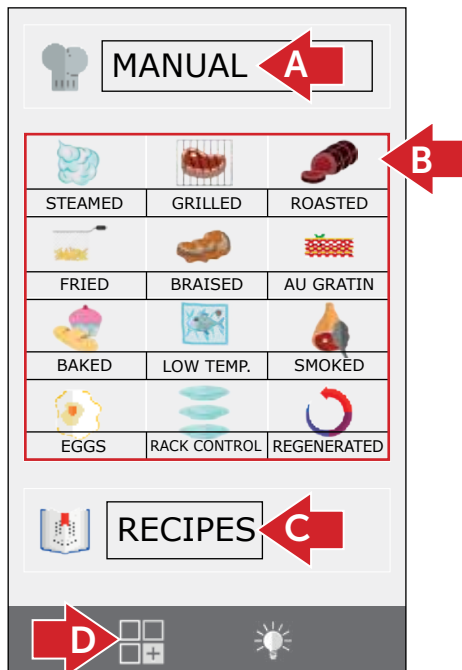

The **COOKING TYPE GROUPS (B)** allow access to type of cooking program, such as grilling. These programs are found inside groups that refer to products of different categories, but which share the same cooking type (for example, grilled fillet steak and grilled fish).

The **RECIPE BOOK (C)** groups cooking programs by product type (for example, meat, vegetables, desserts, etc.).

HOW TO INTERACT WITH THE TOUCH-SCREEN

All of the operations can be selected by pressing the desired item.

To modify a cooking parameter, e.g., the temperature, press the relative field and turn the knob.

To confirm the modification, press the parameter again or press the knob.

MANUAL COOKING MODE

From the home page, press **MANUAL** to gain access to the cooking parameters setting screen.

In **MANUAL MODE**, the oven can be set for individual cooking with one or more phases and/or a cooking program can be set and saved in the cooking type recipe book and/or classic recipe book.

Setting automatic pre-heating

The **PREHEATING FUNCTION** takes the oven to the temperature before the food to be cooked is introduced.

PRE-HEATING is set automatically, but this function can be modified after the **START BUTTON** has been pressed by clicking on the temperature displayed. Also, this function can be activated or deactivated by pressing the **PREHEAT BUTTON** on the right or left.

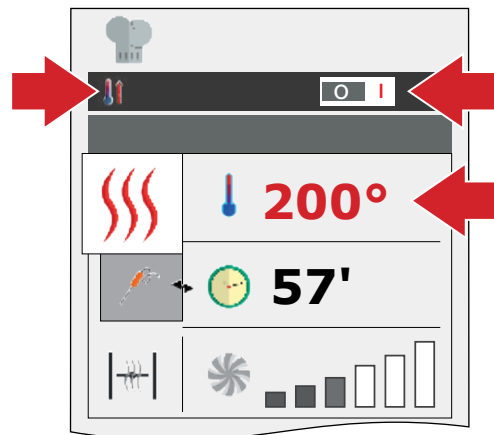

NOTE: Perform preheating with oven empty.

OPERATION—MANUAL COOKING MODE

Setting the COOKING MODE

The convection icon is the default in the CONVECTION COOKING MODE (hot air). By pressing the COOKING MODE BUTTON, the COOKING MODE can be changed to mixed or steam. The cooling cycle (from phase 2 only) or the HOLD cycle can also be set.

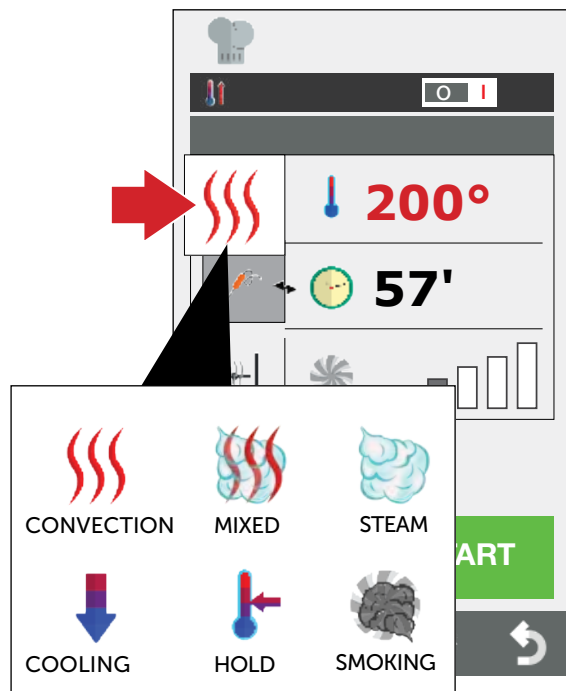

Furthermore, the oven can be set in SMOKE MODE.

COOKING MODES: CONVECTION, MIXED AND STEAM

Setting the cooking temperature

Set the cooking chamber temperature by pressing the TEMPERATURE BUTTON. The set temperature can vary depending on the selected cooking method.

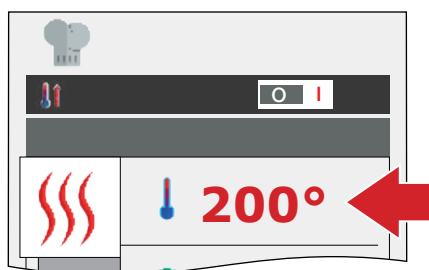

Setting the TIMER/PROBE/DELTA-T

After having selected the COOKING MODE, it is possible to cook in a timed manner or via the core probe.

The timer can be set by pressing INF (INFINITY MODE) countdown.

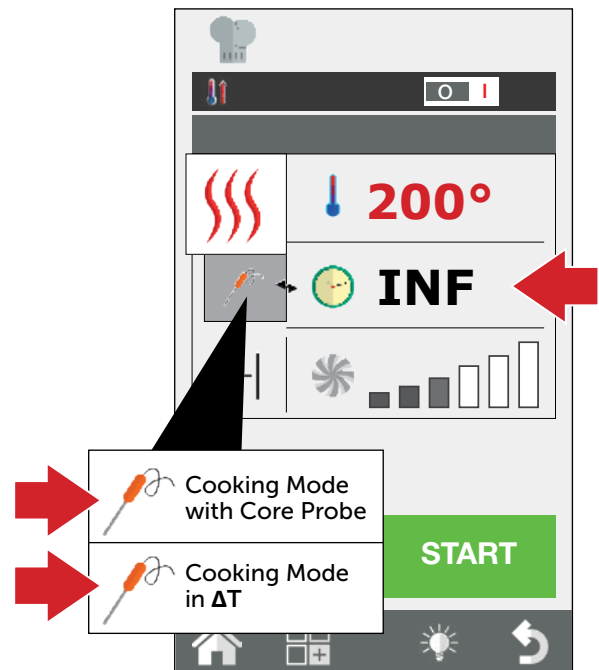

The time is indicated in the minutes format (1h30' = 90 minutes).

When the desired cooking time ends, the oven emits a sound and cooking stops unless other phases are programmed.

If the time is not set, cooking will take place in INFINITY MODE (INF) and the oven will continue to cook until the operator intervenes manually to stop cooking.

When cooking with the core probe it is possible to choose between PIN (COOKING WITH CORE PROBE) or ΔT . This mode allows the product to be cooked more accurately.

Further information regarding ΔT cooking is described on page 30.

MANUAL COOKING MODE

Setting the humidity vent valve

In CONVECTION MODE it is possible to manually set the opening or closing of the humidity discharge valve. When open, the humidity present in the cooking chamber is evacuated allowing the cooking chamber (the product) to dry. Press **HUMIDITY BUTTON** to open or close the valve.

NOTE: This cannot be completed in STEAM MODE.

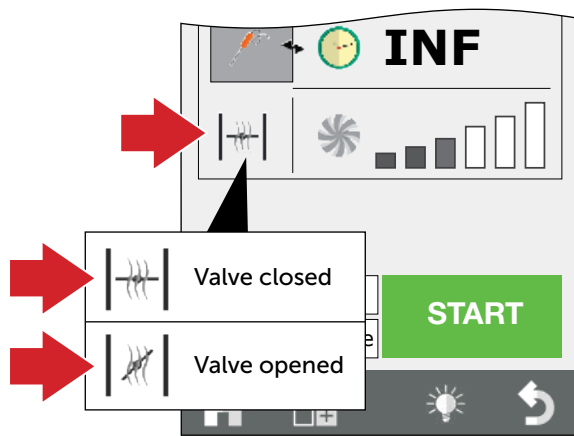

Setting the relative humidity percentage

In MIXED MODE it is possible to set the percentage of humidity that the oven will maintain during cooking. With the patented MeteoSystem humidity control, the oven can measure the relative humidity in the cooking chamber and then add or remove humidity according to the valve set by the operator.

To set the desired level of humidity, press the **HUMIDITY BUTTON** and then select the value.

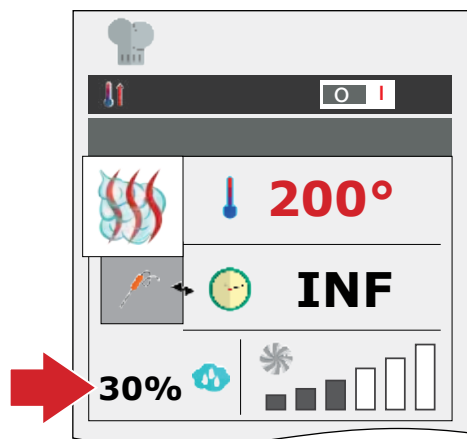

Setting the degree of hydration with the Steam Tuner

The level of hydration of the steam can be set in **STEAM MODE** using the patented **STEAM TUNER** control.

The setting must be made according to the product being cooked and the result you wish to obtain. Other information is described on page 32.

To set the desired degree of hydration of the steam, press the **STEAM TUNER BUTTON** and then set the value (left for dry, right for wet). If the default value is not set, it is normal.

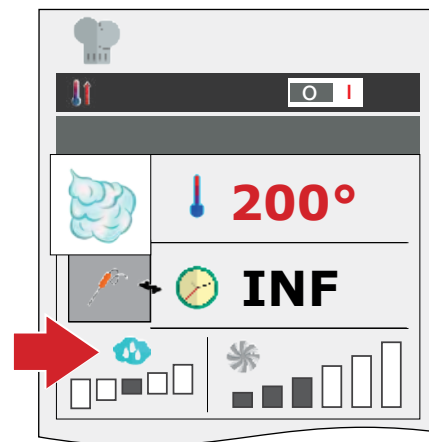

Setting fan rotation speed

The fan rotation speed parameter can be modified in the **CONVECTION** and **MIXED MODES**. In the **STEAM MODE** this setting is automatic.

Fan operation, in relation to the temperature set, evenly distributes the heat inside the oven chamber for uniform cooking and browning of the products on the various trays. Further information is described on page 31.

To set the rotation speed, press **FAN SPEED BUTTON** and select the desired level.

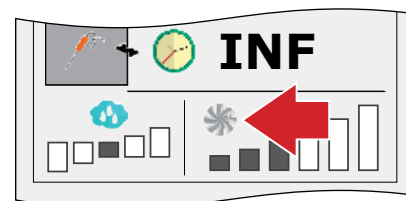

OPERATION

HOLD MODE

The **HOLD MODE** maintains the products at a minimum safe temperature of 135°F (55°C) without product core cooking. It is used at the end of night time cooking to maintain the products temperature until the operator returns.

The **HOLD MODE** by default has humidity set at 20% and the fan speed at 1. For effective holding, it is recommended not to modify fan speed. For roasted products, the recommended hold humidity setting is between 20% and 35%; for brazing or stewing, the recommended hold humidity is between 90% and 100%.

To modify the hold phase, press the **COOKING MODE BUTTON** and select **HOLD**.

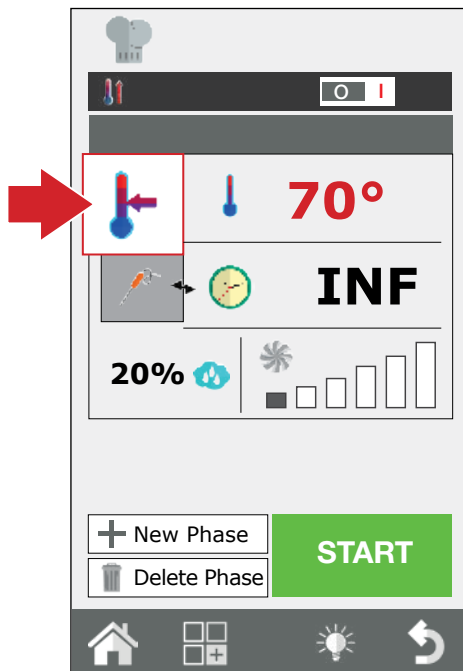

SMOKING MODE

The smoker accessory is required to perform smoking in the oven. This must be inserted into the oven on one of the trays before the smoking phase begins.

If the cooking program requires a cooking phase after the smoking phase, the smoker accessory must be removed from the oven. Refer to the

accessory manual for further information regarding the connection and use of the smoker.

Once cooking has been started by pressing the **START BUTTON**, the oven will request for the smoker to be introduced before the smoking phase begins. At the end of the smoking phase, the oven will request the removal of the smoker. Both these steps must be confirmed by the operator. Only after confirmation will the oven pass to the next phase. The temperature, time, ventilation and humidity

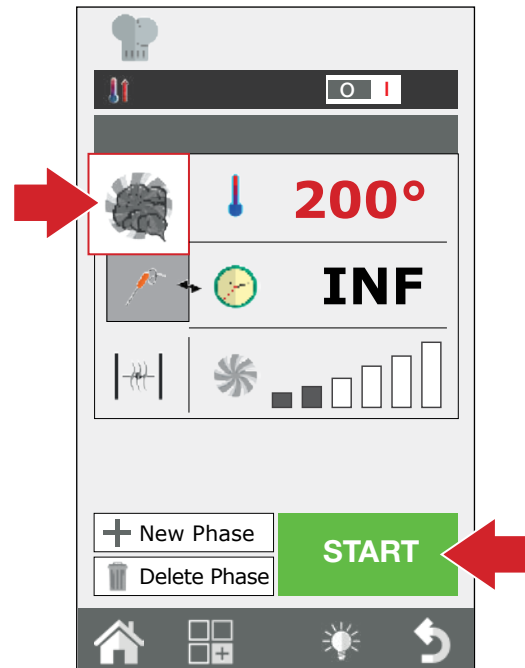

discharge valve can be adjusted during smoking. It is recommended to keep the discharge closed so that smoke does not escape from the chamber.

Smoking can be performed both hot and cold, depending on the type of product and the desired result.

In the cold smoke case, set a temperature between 50° F (10° C) and 87° F (30° C). The minimum temperature in the oven chamber will be similar to room temperature. The chamber can be cooled further by inserting ice. Products used at this low of a temperature must be prepared correctly. Refer to www.haccp.com for additional details.

OPERATION

STARTING AND STOPPING COOKING

After having set the cooking parameters as desired, press the **START BUTTON** to start cooking.

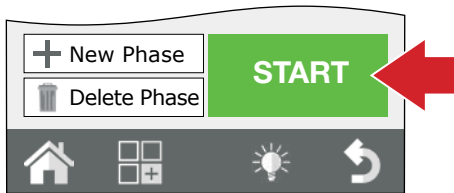

The oven will start in **PRE-HEAT MODE** if this has been previously selected, or otherwise directly in **COOKING MODE**.

Cooking will last until the end of the time set or on reaching the core temperature in the **CORE PROBE COOKING MODE**. If the time is set on infinity, cooking must be stopped manually.

Press the **STOP BUTTON** to stop cooking.

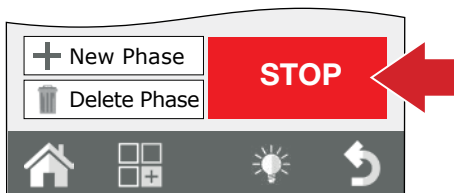

CUSTOMIZED COOKING PROGRAMS

Creating customized cooking programs with up to nine different phases plus pre-heating is easy.

Every cooking phase is represented by a **COOKING MODE** (convection, mixed, steam, etc.) with specific time, humidity, ventilation parameters, etc.

For example, a program can be created for a roast dish that contains a browning phase, a cooking phase, and a hold phase.

To create a successive phase, the previous phase must have a defined time. For example, if phase 1 has the time set on infinity, it will not be possible to create phase 2 because the first phase has no end. The hold phase is an exception, which can be set on **INFINITY** and then have one or more successive

phases, each of which must be started manually. For example, in the night time cooking of roast dishes, it is preferred to brown the dish on return of the operator to the kitchen, therefore after the hold phase.

To pass from one cooking phase to another, hold the number of the phase to which you want to pass down or use the arrows to select the desired phase number and press the **GO BUTTON** at the side of the phase number.

To start the program of a specific phase (different from the first set), select the program, then press the **ADVANCED CUSTOMIZATION BUTTON** and use the arrow to go to the desired phase. After pressing the **START BUTTON**, the program will start from this phase.

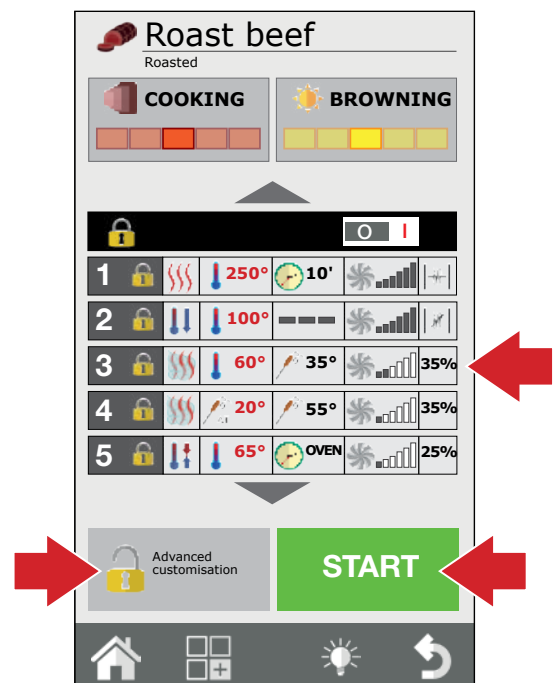

In this program, preheating it will not be performed.

The program can be modified using the Cooking Tuner interface before pressing the **ADVANCED CUSTOMIZATION BUTTON**.

OPERATION

CREATING A COOKING PROGRAM

A cooking program can be made up from several phases, which the oven performs in increasing order (phase 1, phase 2, phase 3...) passing from one to another automatically. In between phases, there will be an audible sound to identify the phase change.

After having set the parameters relative to the initial phase (phase 1), press the **NEW PHASE BUTTON** to create the next phase.

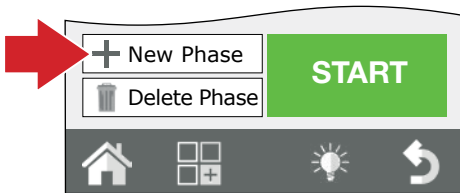

Then, set the parameters of phase 2.

Additional phases can be created by repeating the above steps.

At the end of programming, press the **START BUTTON** to start cooking.

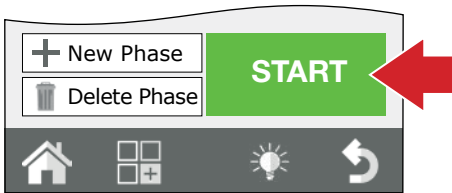

Press the **DELETE PHASE BUTTON** to delete a phase.

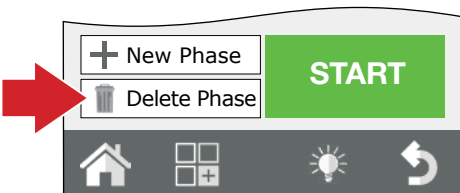

Setting a cooling phase between two phases

The temperature inside the oven chamber may have to be cooled between one phase and another. For example, when roasting the chamber must be cooled between the browning phase (at high temperature) and the cooking phase (at low temperature).

This operation can be performed automatically by selecting an automatic cooling phase. The automatic cooling phase can only be set from phase 2 onwards.

After having set a high temperature phase, create a new phase and select **AUTOMATIC COOLING** from the **COOKING MODES BUTTON**.

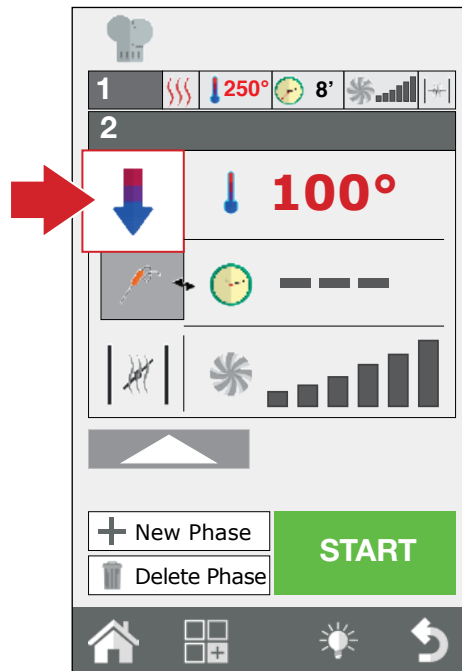

Once this mode has been selected, the oven will propose default temperature, ventilation, and humidity discharge valve values. Set the desired cooling temperature min. 212° F (100° C).

In order to make cooling as fast as possible, do not modify the ventilation and humidity discharge valve values unless necessary.

OPERATION

SAVING A COOKING PROGRAM

A cooking program created can be saved in order to use it at a later date, inside a cooking type group (grill, braise, steam, etc.), or within a product type group in the classic recipe book (meat, fish, chicken, etc.). It is also possible to save the program simultaneously in both recipe books. For example, grilled fillet steak can be saved simultaneously in grill and meat.

After having created a cooking program, press the **FUNCTIONS BUTTON** to access the program's function screen.

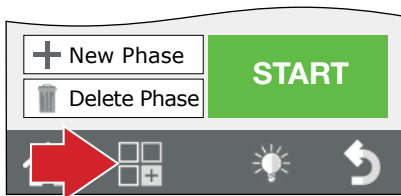

Press the **SAVE PROGRAM BUTTON** and then press the **SAVE BUTTON**.

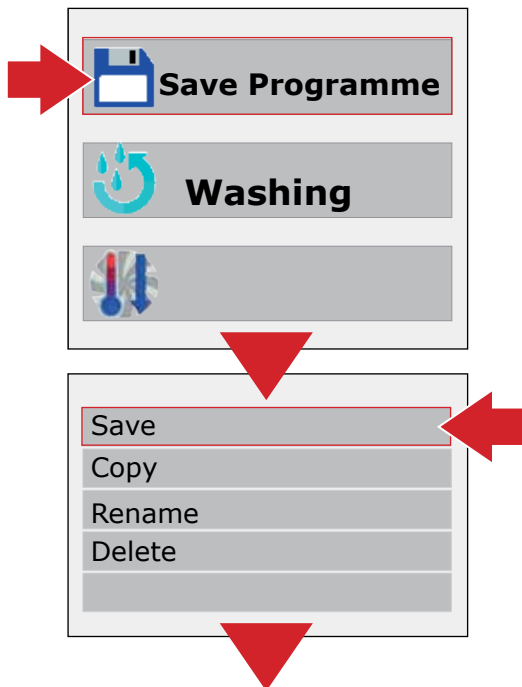

In the next screen, select the group in which to save the setting (example **ROASTED**). To save the program, press the **FORWARD BUTTON**.

Enter the **PROGRAM NAME** and press the **SAVE ICON BUTTON** to save.

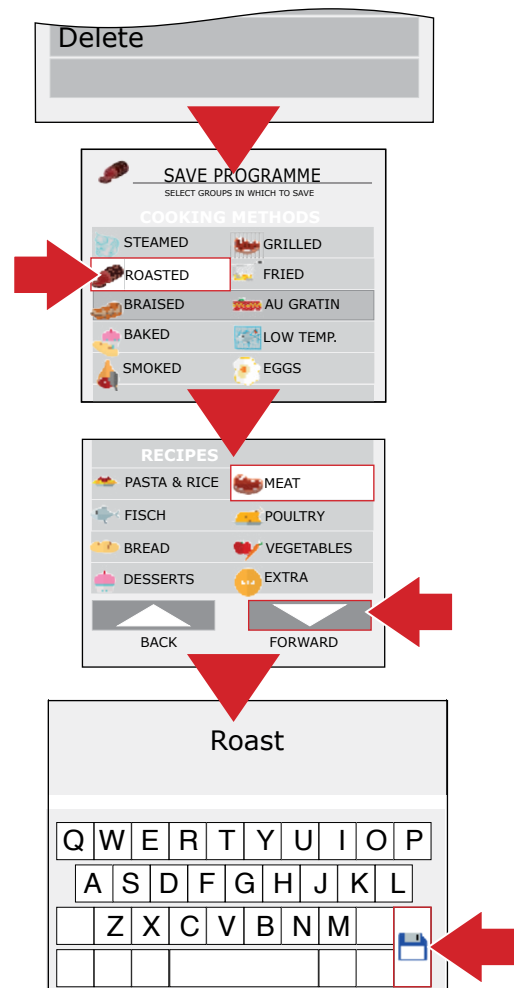

OPERATION

MODIFYING A COOKING PROGRAM

On delivery, the oven will have some cooking programs preloaded.

Both the preloaded cooking programs and the newly created ones can be customized.

To modify a program, first select the desired program from one of the recipe books. Once open, a summary of the set phases can be seen. In this **READING MODE** it is not possible to modify the cooking parameters. If one or more cooking parameters are to be changed or automatic pre-heating is to be activated/deactivated, press the **ADVANCED CUSTOMIZATION BUTTON** to release the program and make the desired modifications. Use the **ARROW BUTTONS** to select the phase to be modified and change it at will.



Once the modification has been completed, cooking can be started directly and/or the program can be saved to overwrite the previous setting or create a copy with a different name.

COPY, MOVE, RENAME AND DELETE

Every program present can be copied, moved, renamed, or deleted totally or partly.

Copy a program

If a new program is to be created by starting from a program already present (because the old and new program share some cooking aspects), it can be copied.

Select the base program, open it, and modify it by pressing **ADVANCED CUSTOMIZATION**.

Make the desired modifications and using the **FUNCTIONS BUTTON**, select **SAVE** and then **COPY**. Select the group where in which to save the program and then enter the new name and press the **ENTER BUTTON** to confirm.

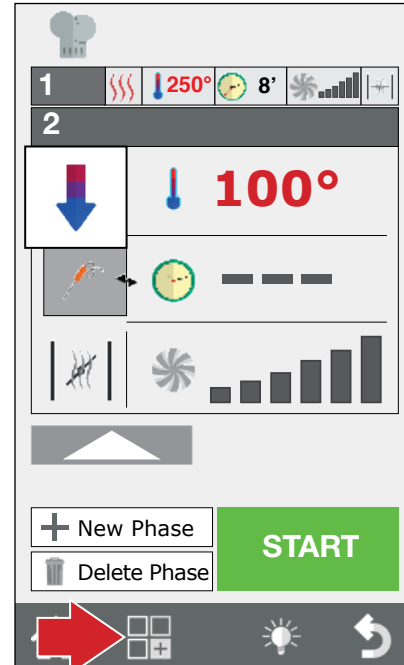

Move a program

If you want to move from one program group to another, open the program and press the **FUNCTIONS BUTTON**. Select **SAVE** and then **MOVE**. **SELECT** the new group(s) where it is to be moved and confirm with the **FORWARD BUTTON**.

OPERATION

Rename a program

Open the program, press the **FUNCTIONS BUTTON**, select **SAVE**, and then **RENAME**. Enter the new name and press **ENTER**.

Delete a program

Open the program, press the **FUNCTIONS BUTTON**, select **SAVE**, and then **DELETE**. Confirm the choice by pressing **YES** in the pop-up that is shown.

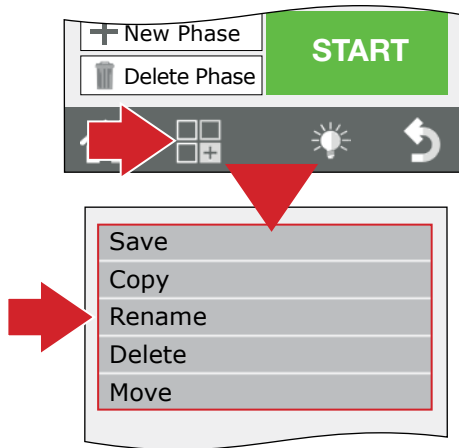

SELECTING A PROGRAM FROM THE MENU

The oven is supplied with a series of cooking programs preloaded in the memory. These are divided by cooking type (grilled, roasted, fried, etc.) and by product type (meat, fish, vegetables, etc.).

They can be viewed both from the main menu, which divides them by cooking type, and from the recipe menu, which divides them by product type.

Cooking methods

The **COOKING MODES** are displayed on oven start-up, where the cooking programs are collected together.

By selecting the desired **COOKING MODE**, the list of all cooking programs will open relative to that **COOKING MODE**.

Select the desired program from the list.

The product recipe book

Press the **RECIPES BUTTON**, to display the **COOKING MODES** divided by product category (meat, fish, vegetables).

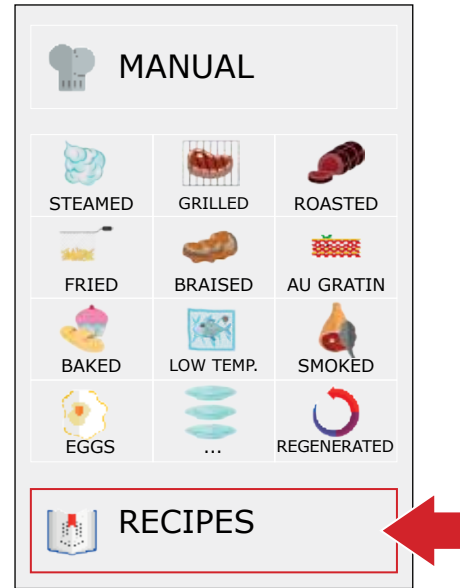

Select the desired product category, to view the list of all cooking programs relative to that category.

Select the desired program from the list. Press the **COOKING TYPES BUTTON** to go back to the display of the types of cooking.

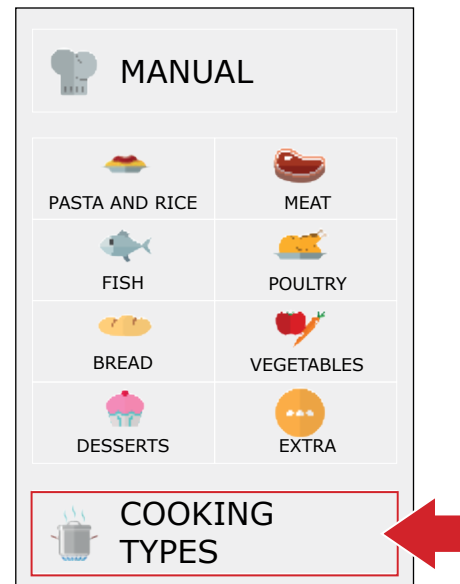

OPERATION

THE RECIPETUNER INTERFACES

Once a cooking program has been opened, it can be modified simply by using the RECIPETUNER interfaces. Depending on the type of cooking selected, a product's cooking, browning, degree of rising, etc. can be easily modified. The RECIPETUNER FUNCTION is present for the pre-set programs and the new ones created. The RECIPETUNER system recognizes the phase to be modified in order to meet cooking requirements.

Function of the interfaces

Cooking: Allows modification of the cooking of a product. Starting from average cooking at 140° F (60° C), from the left the following types of cooking will be obtained: rare, medium-rare, medium, medium-well done and well done.

Browning: Product browning can be modified on five different levels from the lightest (on the left), to the most intense (on the right).

Humidity: During braising, this refers to the residual humidity on the product at the end of cooking.

Rising: it is possible to add the degree of rising (20 minute steps) to perform an automatic rising and cooking program.

Cooking method	Interfaces	
Grilling	Cooking	Browning
Braising	Moisture	
Au gratin	Cooking	Browning
Frying	Browning	
Bakery products	Rising	Browning
Low temperature	Cooking	

RACK CONTROL MODE

The RACK CONTROL FUNCTION allows separate control of up to 10 different levels during cooking. This function manages a unique COOKING MODE setting, temperature, humidity, etc. However, each level may have a core cooking time or temperature independent from the others.

Press the RACK CONTROL BUTTON to access the list of pre-set programs (breakfast, lunch, multibaker, mixed steam, etc.). Each of these programs will contain a series of dishes.

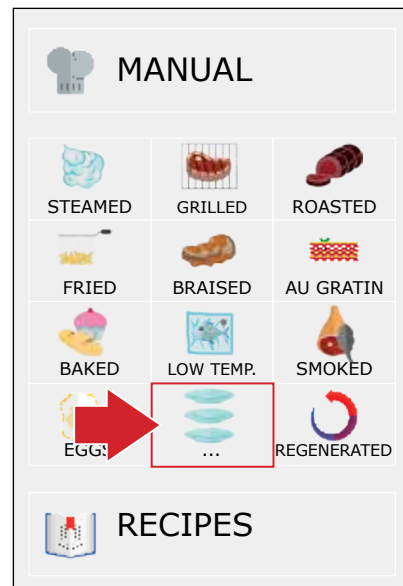
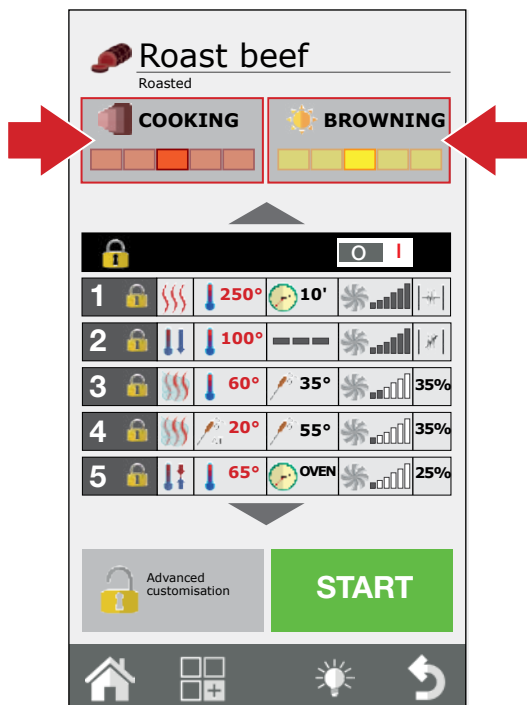

OPERATION

Example: The lunch program will contain the dishes regarding the lunch service such as the grilled steak, Milan-style meat, stir-fried vegetables, and lasagne. It is possible to create and add other programs and sub-programs (dishes).

USING THE RACK CONTROL FUNCTION

Selecting a rack control program

Selecting one of the programs from the list (for example, lunch) will open a screen with the general program settings on the left: **PRE-HEAT, COOKING MODE, TEMPERATURE, FAN, BUTTERFLY VALVE, HUMIDITY** or **STEAMTUNER** if the **MIXED OR STEAM COOKING MODE** is set. The 10 empty levels will be seen on the right.

Starting a Rack Control Program

All rack control programs basically function with infinite time. Therefore, independently whether the program requires pre-heating or not, start the program pressing the **START BUTTON**.

Add the dishes to the program levels

After having started the program and at the end of pre-heating (if present), press any one of the **RIGHT HAND BUTTONS (1-10)** to add the name of the dish to insert in the level selected.

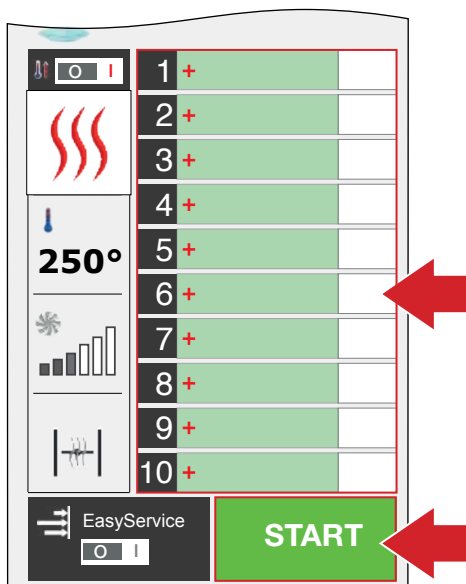

The list of set sub-programs will open (dishes). Select one and it will automatically be added to the previously selected box. The dish must be placed inside the oven at the same time it is selected. Continue by adding the rest of the servings that are to be cooked. It is possible to add and manage up to a maximum of 10 levels per time.

The time remaining until the end of cooking will be seen beside of the level name or, if probe pin cooking has been selected, beside the real core temperature.

Create new names for dishes levels

New dish names can be added both to the programs created by the user and to pre-set programs.

Enter the list of dishes and click on an empty box, press the **NEW BUTTON**. Enter the **NAME** of the serving along with the **COOKING TIME** and the **CORE TEMPERATURE**.

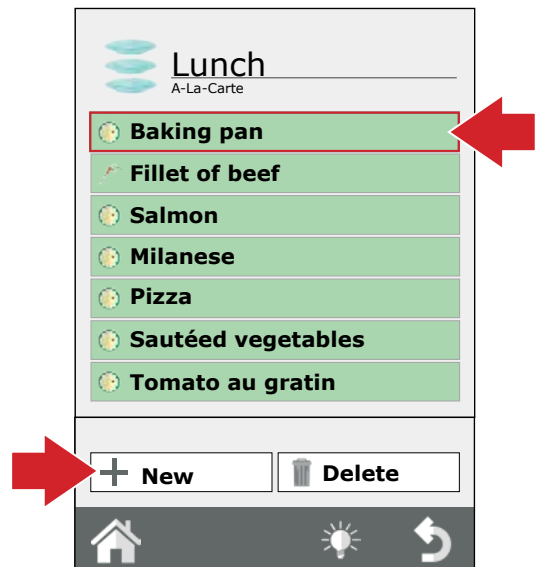

OPERATION

Press the **SAVE ICON**. Continue pressing **NEW** to add others.

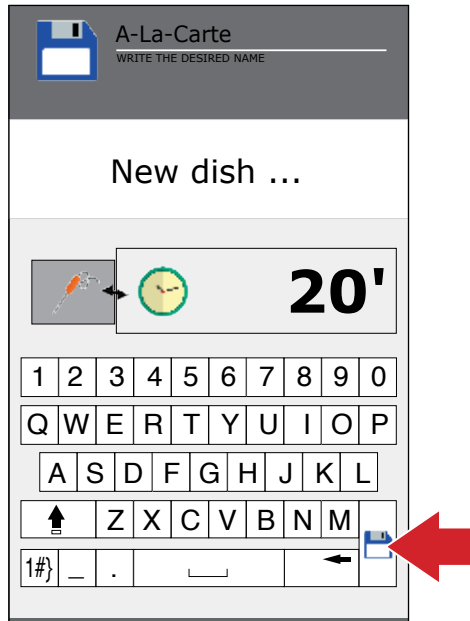

Delete a dish from the list

To delete a serving from the list hold the name to be removed down for a few seconds. This operation is only possible if the cooking of this dish is **NOT** active.

Direct or scheduled use

RACKCONTROL can be used in **DIRECT MODE** and in **SCHEDULED MODE**.

The first mode is that described on the previous page (add the plates to the program) in which the dishes are added after having pressed the **START BUTTON** (and at the end of pre-heating, if present).

In the **PROGRAMMED MODE** the servings are added when the oven is in **STOP MODE**, i.e. when it is not cooking. The levels selected will not activate. At the end of pre-heating, if present, press the **START BUTTON** to activate the servings one by one, pressing the time box on the right.

Modifying the time or the temperature of the dish probe

To modify the set cooking time or the set core probe of a dish in manual mode, press the "+" button until the screen changes, then enter in the desired time or temperature.

To modify in a specific program, enter the list of dishes, press the name of the dish until the screen changes, then enter the new time (or probe temperature). The name of the serving can also be modified in this way.

If the time of a serving is to be changed during cooking, press the remaining time box and enter the new time or temperature probe.

The end of cooking a dish

At the end of the pre-established cooking time for a dish (or on reaching the core temperature set), the oven will emit a sound and **END** will appear in the time box. At this point, open the oven door and remove the product that is prepared. Opening and closing the door will automatically reset the level.

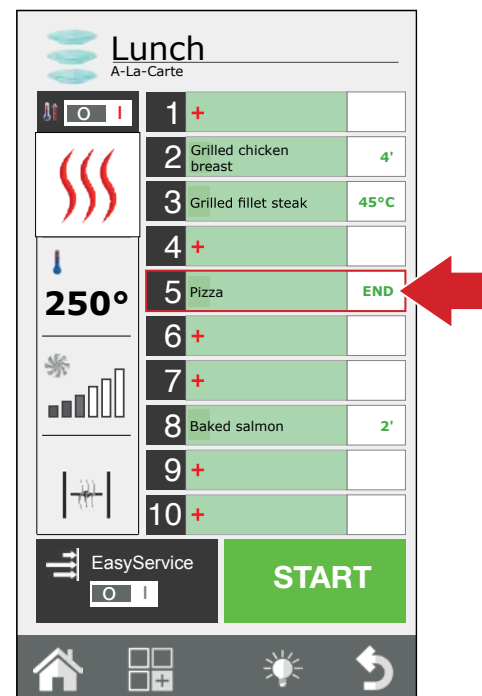

OPERATION

Quick entry of a dish

During the cooking phase, the necessity to cook a product not present in the list can be accomplished. It is possible to quickly insert a dish in the RACKCONTROL without having to record it with a specific name. The generic name of the tray will appear.

To do this, click on an empty level and select the sub-program (example: BAKING PAN). This represents a sub-program to which a different time can be set each time. Several tray servings can be introduced into the RACKCONTROL simultaneously.

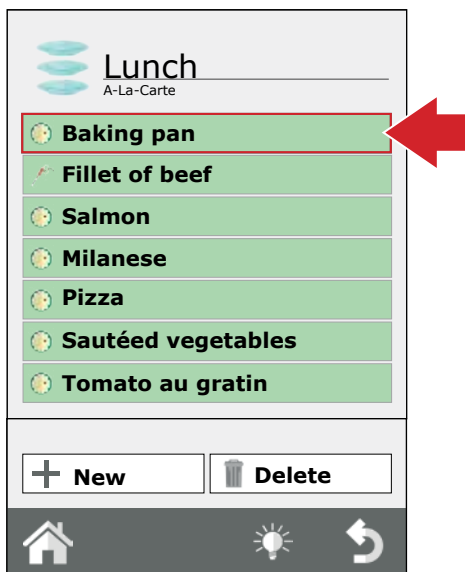

Modifying a RACKCONTROL program

To modify a RACKCONTROL program, operate on the sets shown in the left hand column (A). The COOKING MODE, TEMPERATURE, FAN (excluding STEAM MODE) and BUTTERFLY VALVE (HUMIDITY OR STEAMTUNER) can be modified at any time.

Once the modification is made, you may save, copy, rename or delete the program. In this case, press the FUNCTIONS BUTTON and proceed as explained on page 26 of this instruction manual.

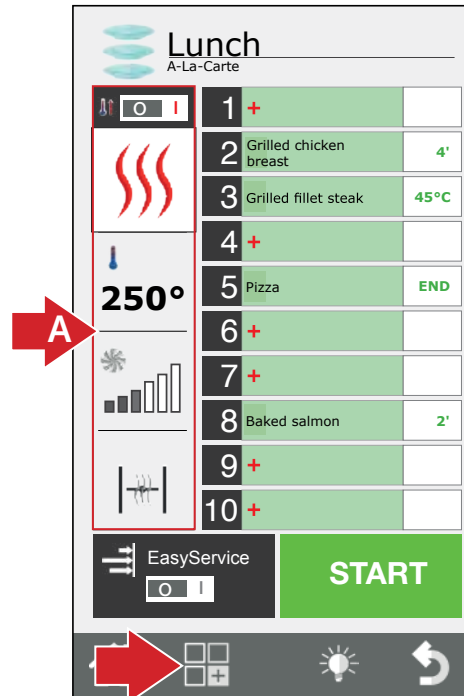

CREATING A NEW RACKCONTROL PROGRAM

In addition to the RACKCONTROL programs already present, customized programs can be created.

From the home screen, press the RACKCONTROL ICON. Then press the MANUAL BUTTON.



OPERATION

The Manual program allows the creation of a new program and also works in **RACKCONTROL MODE** without memorizing the program. In the second case, on exiting the program, the cooking sets set will be lost.

To create a new program, enter the **RACKCONTROL MANUAL** section and enter the desired cooking settings into the left hand column. Press the **FUNCTIONS BUTTON** and save the program as explained on page 26 of this instruction manual.

Only after the program has been saved is it possible to enter the list of dishes.

Using the RackControl in MANUAL MODE

If the program set is to be saved, RackControl can be used in **MANUAL MODE**.

However, in this mode specific plates cannot be saved and the generic name "Tray" is displayed for all levels.

USING THE EASYSERVICE FUNCTION IN RACKCONTROL

RackControl is designed to cook dishes separately on different levels. Dishes can be introduced at the same time or at different times. At the end of cooking as the time expires, the oven will indicate which level has been reached.

By activating the **EASYSERVICE FUNCTION**, it is possible to have all of the dishes ready at the same time. In this way, the oven informs when it is time to insert the dishes at the various levels so that they are ready at the same time.

Only levels with the time parameter setting can be selected (not with the core probe parameter).

Activate EasyService

The **EASYSERVICE FUNCTION** is only available when the oven is in **STOP MODE** and can be activated by moving the **EASYSERVICE SWITCH BUTTON** to position I. This action allows access to the list of dishes of the relative **RACKCONTROL** program.

Select the dishes to be served at the same time (maximum 10) and press the **START BUTTON**.

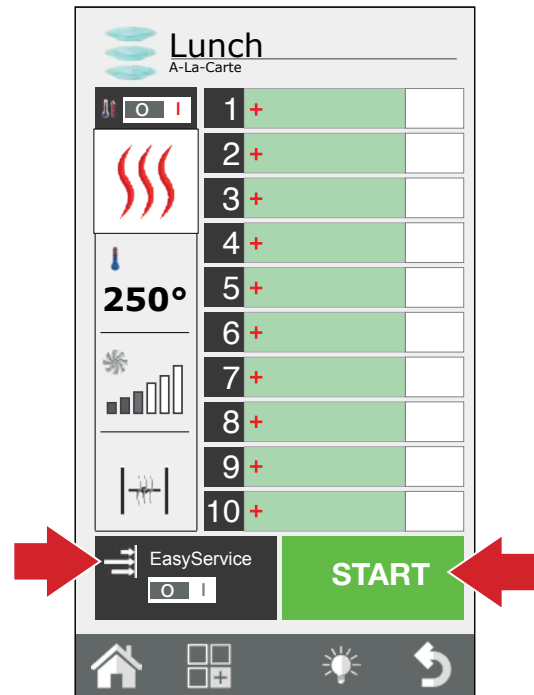

At the end of pre-heating (if present), the oven will beep and the word **IN** will appear in the right hand box. Enter the dishes with the longest cooking time. The acoustic signal is reset and the countdown begins with the opening and closing of the door,

In the other levels, the respective time to place each dish in the oven is highlighted in green. The warning sound starts intermittently for 15 seconds. Wait until the timer reaches 0 and the wording **IN** is displayed before placing the dish in the oven. By doing this all of the dishes will cook exactly at the same time.

OPERATION

Using RackControl with Easy Service

During the use of EasyService, other plates can be added in RACKCONTROL MODE, which will be controlled independently from those selected for EasyService. Both functions can be used at the same time by first activating EasyService and then adding other plates in RACKCONTROL MODE.

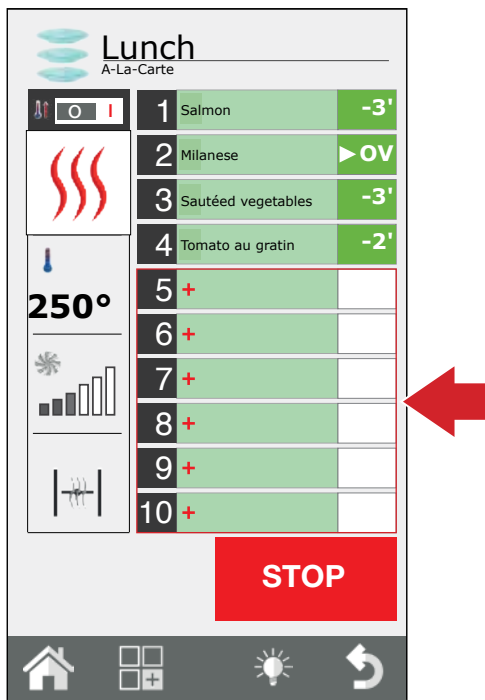

EasyService cannot be activated if RackControl is already activated.

THE REGENERATION FUNCTION

The REGENERATION FUNCTION was developed to regenerate (or take to service temperature) pre-cooked and blast chilled/frozen products 34° F (1° C) to 39° F (4° C). This function is particularly suitable for regenerating products already on the plate, but can also be used for the regeneration of whole products on trays.

Accessing the REGENERATION FUNCTION

Press the REGENERATION PICTOGRAM on the HOME page.

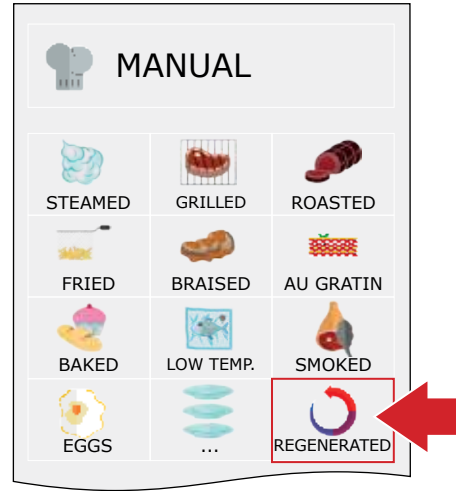

The regeneration programs list will be displayed. Select the desired program from the list or press MANUAL to create a customized program.

Using the REGENERATION FUNCTION

Select MANUAL program from the regeneration programs list to set the oven to regenerate one or more products.

The screen will display SOFT or CRISPY FUNCTIONS. Select SOFT if a dish cooked at low temperature is being regenerated. Select CRISPY if a high temperature dry phase is to be performed to regenerate the product's surface crust at the end of regeneration. The functions are optional and can both be disabled. They cannot both be selected at the same time: they are opposite to each other.

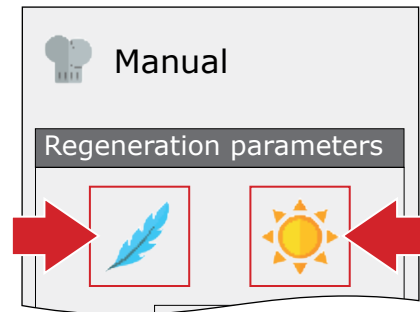

OPERATION

Enter the **REGENERATION TIME (A)** or the **CORE TEMPERATURE (B)** and press the **START BUTTON (C)**. The oven will pre-heat automatically (empty) and then notify when to place the items in the oven via a sound signal and display on the screen.

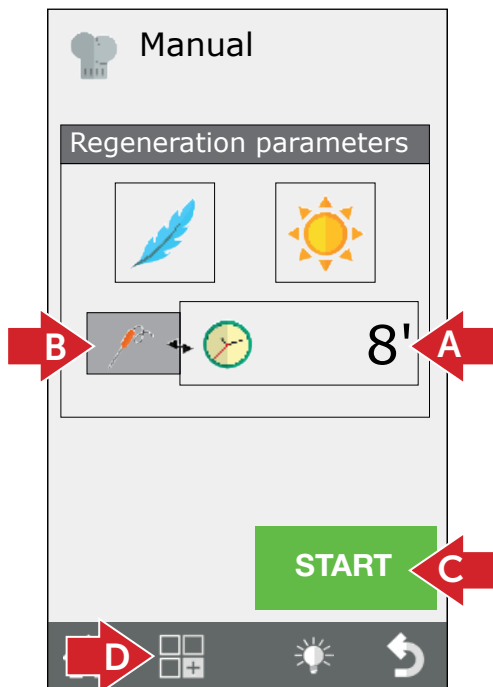

REGENERATION PROGRAMS

Saving a new program

Personal programs can be added to the programs already present.

To create a new program, select **MANUAL PROGRAM** from the list of regeneration programs and set the **REGENERATION TIME** (or the **TEMPERATURE OF THE CORE PROBE**) and activate one of the **SOFT** or **CRISPY FUNCTIONS** if necessary.

Once the desired parameters have been set, press the **FUNCTIONS BUTTON** and save the program in the oven memory as explained on page 21 of this instruction manual.

Modifying a program

If a program that is already saved is to be modified, select it from the programs list of the regeneration menu.

Make the modifications desired.

Use the **START BUTTON** to start the program or to save the modifications by pressing the **FUNCTION BUTTON (D)** and then the **SAVE BUTTON**.

Rename/Delete a program

Like the cooking programs, the Regeneration programs can also be renamed and deleted.

From the program selected, through the functions menu, access the **SAVE FUNCTION** and rename or delete to perform the desired procedure.

THE CORE PROBE AND COOKING IN ΔT

Positioning the probe

The probe detects the temperature via a tip positioned in proximity of the probe.

The tip of the probe must be inserted into the center and thickest part of the product.

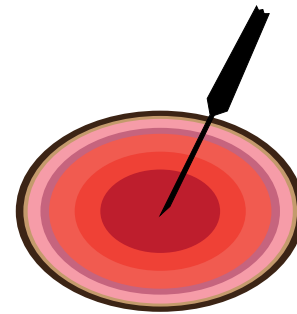

Cooking in ΔT (Delta-T)

The ΔT FUNCTION is used mainly for slow, low temperature cooking.

In ΔT MODE instead of setting the temperature in the chamber, the temperature that the oven must maintain as constant between the product core temperature and the chamber must be set.

OPERATION

As the core temperature rises, the temperature in the chamber will increase in parallel. A probe must be used for the ΔT FUNCTION. It is advised to set ΔT between 15°C and 30°C maximum.

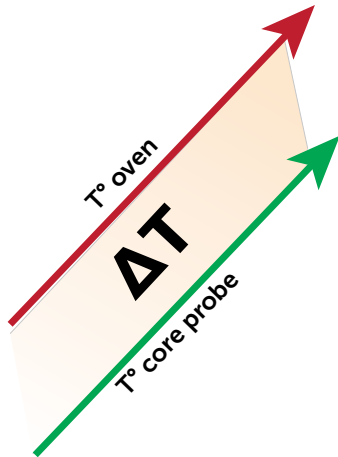

Food	Cooking	T° core
Red meat	Rare	125° F (50° C)
	Medium	140° F (60° C)
	Well done	158° F (70° C)
Veal, pork and white meat in general	Well done	158° F (70° C)
Chicken	Well done	176° F -194° F (80-90° C)
Boiled and braised meat	Well done	176° F -194° F (80-90° C)
Fish	Well done	152° F -161° F (67°-72° C)

RECOMMENDATIONS FOR COOKING

Roasts

For more effective cooking, place roasted foods on the steel rod grill in order to achieve more uniform cooking between the top and bottom of the food without having to turn it during cooking.

To collect the juices, place a tray on the lower level of the oven.

Grilling

The grill accessory must be used for grilling in the oven. Grill on the aluminium rod grill for the best results.

During grilling, the oven is typically set in **CONVECTION MODE** with valve open and temperature between 446° F (230° C) and 518° F (270° C), depending on the type of product and browning that is desired, with the ventilation set between 4 and 6.

Frying

All breaded and pre-fried frozen foods can be fried. For breaded products, spray a thin layer of oil so that it is absorbed by the breading. Frozen pre-fried products can be fried without adding oil. Use non-stick aluminium trays or frying baskets. Set the convection oven with the valve open at a temperature of 482° F (250° C) and ventilation between 4 and 6.

COOKING ADVICE: COOKING UNIFORMITY

The uniformity of cooking can be modified according to the type of product by lowering the temperature and increasing or decreasing the fan rotation speed.

Using the correct trays increases the oven's general cooking uniformity. Always select the tray with the minimum depth possible for the product to be cooked. Aluminum trays offer more uniform cooking than steel trays.

RECOMMENDATIONS FOR COOKING-VACUUM COOKING AND PASTEURIZATION

Vacuum cooking

Cooked a product directly inside a vacuum bag results in particularly soft and flavored meat and decreases the perishability of the product.

Vacuum pack the product using proper cooking bags, then set the oven with the MIXED CYCLE at 100% humidity and fan speed between 3 and 4. The cooking chamber temperature must be a maximum of (5-10° F) above the temperature the core must reach. For example, to vacuum cook an average fillet 140° F (60° C) at the core, set the oven temperature at 145° F (63° C).

OPERATION

Pasteurization in jar





A product is considered pasteurized when the core temperature reaches a value between 181° F (83° C) and 185° F (85° C).

Based on the type of product, dimension of the jar, and amount of product it contains, the time to reach the core temperature may vary. It is therefore recommended to use the core probe on a sample jar (perforating the lid to allow the probe to enter) in order to detect the temperature of the entire production batch.

At the end of cooking the product must be blast frozen quickly to 37° F (3° C) to end the pasteurization cycle.

RECOMMENDATIONS FOR COOKING—HYDRATION OF THE STEAM

With the patented control for the hydration of the steam, SteamTuner can modify the quality of the steam, from very dry to very wet, according to the product to be cooked. The dry steam is generally used for delicate products, while the wet steam is normally used for products that have hard fibers and are therefore more difficult to cook.

	VERY DRY	248° F (120° C)	Pastry such as: steamed sponge cake, muffins, crème caramel.
	DRY	167° F (75° C)	Fish and shellfish in general
	STANDARD	176° F (80° C)	Steamed chicken meat
	MOIST	203° F (95° C)	Red meat and boiled meats in general
	VERY MOIST	239° F (115° C)	Vegetables whole and in pieces, pasta and rice

FUNCTIONS MENU

The FUNCTIONS MENU found on the HOME screen allows access to the routine maintenance functions and oven use settings.

WASHING

Four types of washing that can be selected: **HARD**, **NORMAL** and **SOFT**, or the **RINSE ONLY MODE**.

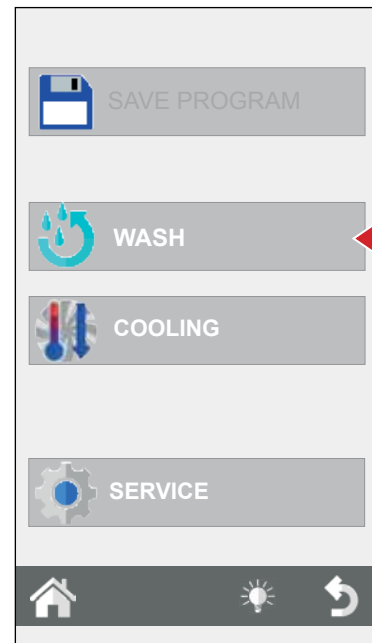

Choose one of these types of washing based on the amount of food residues and deposits of fat in the oven cooking chamber. **HARD** should be used for deep washing and very resistant dirt. **SOFT** should be used for a light wash.

Washing duration varies based on the type:

SOFT	approx. 1 hour 15 mins
NORMAL	approx. 1 hour 30 mins
HARD	approx. 2 hour 30 mins

The **RINSE ONLY MODE** duration depends on the use of a rinse aid:

duration of **approx. 10 mins without rinse aid**,
duration of **approx. 20 minutes with rinse aid**.

OPERATION

Select the type of detergent; liquid (LIQUID DEGREASER) or solid (SOLID TABS).

Additionally, the program will ask for the selection between rinse aid DESCALER & RINSE, VINEGAR or NONE.



Once selections have been made, press the **OK BUTTON** and verify the product levels (detergent and rinse aid) in the tanks.

Put the tanks of detergent and rinsing aid near the oven and insert the small white and red tubes which are placed under the oven into their respective tanks:

CLEAR tube -> RINSE AID
RED tube -> DETERGENT

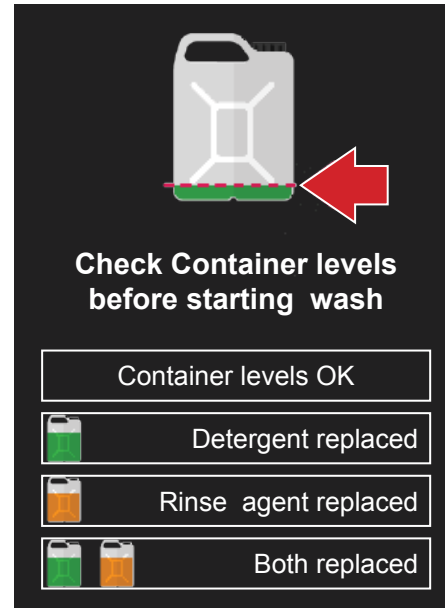

IMPORTANT:

For correct maintenance and quality of the oven chamber, using the detergent recommended by the manufacturer is required.

THE USE OF A NON-APPROVED DETERGENT CAN VOID THE WARRANTY!

COOLING

This function quickly reduces the temperature inside the oven chamber, in order to pass from a high temperature type of cooking to more delicate cooking at lower temperatures (for example, to pass from roasting to steaming vegetables).

Press the **START BUTTON** and the fan will begin. Open the oven door to promote the exit of hot air and the entry of cooler air. This allows the desired temperature to be reached in a short time in order to proceed with more delicate cooking.

OPERATION

For safety reasons, the **COOLING FUNCTION** can be enabled only with the door closed. The door can be opened only after this program has started. By default the oven cools the chamber to **122° F (50° C)**, but a custom value can be set. Upon reaching this temperature, the oven stops cooling and emits a sound signal.

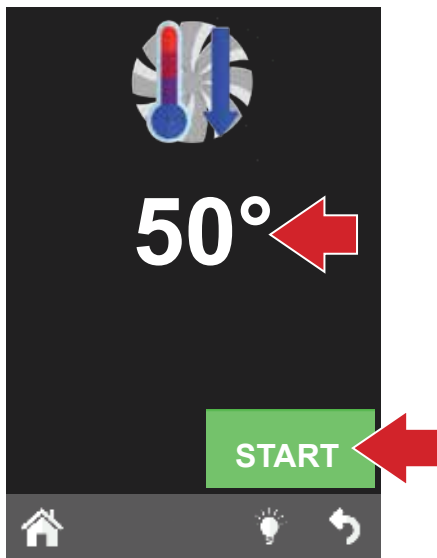

SERVICE (This area is only available when the control is unlocked.)

The service menu includes four functions: **CONFIGURATION**; **LOG DISPLAYS**, **BOILER CLEANING**; and **ADVANCED SERVICES** which displays a range of functions and procedures for maintenance of the oven.

CONFIGURATION

A series of parameter configurations can be performed from this menu:

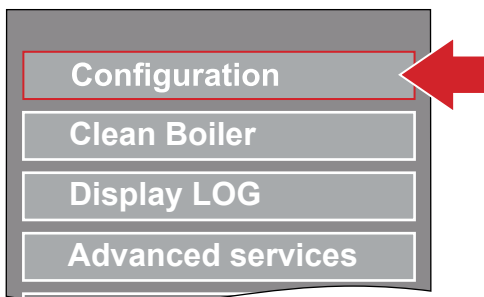

Date and Time

The **DATE AND TIME FUNCTION** allows the user to update the current date and time in order to use the oven.

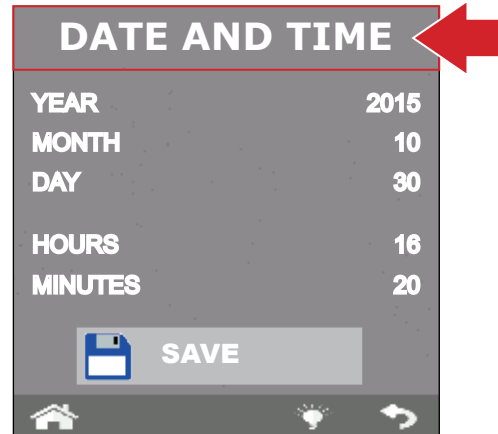

System Information

The **SYSTEM INFO FUNCTION** displays the software version installed in the oven, the serial number of the oven, and the number of hours passed since the last time the steam generator was cleaned (Symbiotic Steam System models only).

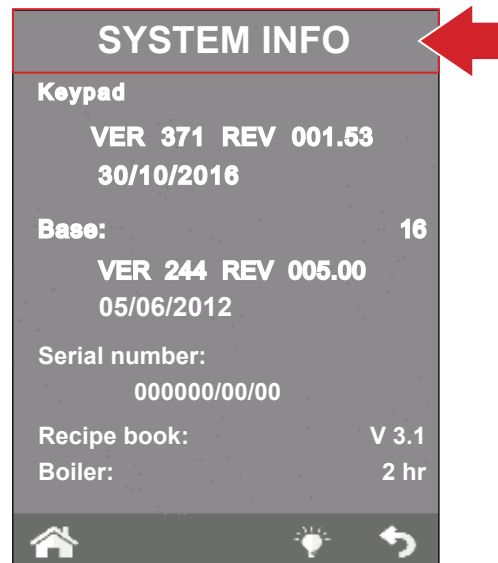

OPERATION

Language

The language in which the commands and messages are seen on the display can be selected using this function.

Shower Block/Unblock

This function allows the solenoid valve that delivers water to the retractable hand shower, to be open and closed.

You can choose the following options:

- Shower always usable
- Shower active with door open
- Shower always blocked

Lighting

The LIGHTING FUNCTION allows the brightness of the display to be adjusted. Select this function, then adjust the brightness using the knob on the control panel and press SAVE.

DISPLAY LOG

The function proposes the chronological list of the ALARMS LOG and the WASHING LOG.

ALARMS LOG displays all of the errors that have been detected and shown on the oven display during its operation.

WASHES LOG displays all of the washes and the type of wash performed by the oven with the date and start time recorded.

ADVANCED SERVICES

This function is protected by a password and allows access to the configuration settings and inspection functions reserved for qualified technical staff.

Date Import/Export

By connecting a USB under the control panel, the import and export functions of some of the functions described above are activated.

OPERATION MAINTENANCE AND CLEANING

Insert an empty USB to export the RECIPE BOOK and HACCP LOGS (when activated this function records the cooking procedure and all its data: time, chamber temperature, core probe temperature, start-up and all phase changes, etc.).

Insert a loaded USB drive to import data (for example, new recipes, new parameters, or new languages) to the oven software.

MANUAL CLEANING

Disconnect the appliance from the electric power supply before performing any cleaning or maintenance actions. At the end of the working day, clean the appliance, both for reasons of hygiene and to prevent operating faults.

The oven should never be cleaned with direct water or high pressure jets. Moreover, the appliance should not be cleaned with ordinary steel brushes or scrapers.

Wait until the cooking chamber is cold. Remove the tray-trolley stops. Remove the loose residue manually and put the detachable parts in the dishwasher.

You should use warm soapy water to clean the cooking chamber. All the surfaces must be thoroughly rinsed afterwards, ensuring that there is no detergent residue.

To clean the outside of the oven, use a damp cloth and a mild detergent.

Cleaning Chemicals

Use only Giorik approved cleaning agents to clean the oven interior.

Unauthorized cleaning agents may discolor or harm interior surfaces of the oven.

Read and understand the manufacturer's label and material safety data sheet before using the oven cleaner and rinse aid.

Always use protective gloves and eyewear when handling any chemical including wash or rinse liquids.

Use and follow all directions supplied by the manufacturer of the liquids listed on the containers and as instructed by your manager.

Observe all rules for storage of chemicals supplied by the chemical manufacturer.

Do not use unauthorized abrasive cleaners on the oven for any reason, including any wire or metal scrapers, or pressure washing of any kind.

NOTE: Damage caused to any surface, gasket, or part due to abrasive chemicals or tools because of improper cleaning or without using the specified cleaning agents will void any warranty claims. Detergent must contain less than 5% (by weight) Sodium Hydroxide.

If the oven is equipped with the automatic cleaning system, the cleaning hoses will be pre-attached to the unit. Please take care placing the correct hose in the correct chemical. The red hose is for cleaning detergent and the clear hose is for rinse aid.

Giorik Approved Cleaning Chemicals:

Detergent – ECOLAB Greasecutter Plus
Rinse Aid – ECOLAB R/O Free Rinse Additive
Solid Tablet – Giorik

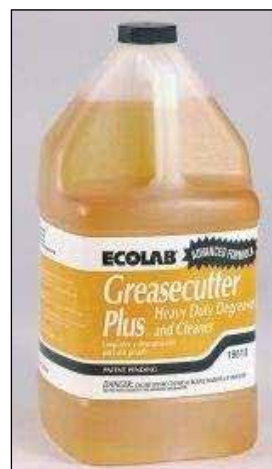

Detergent



Rinse Aid

MAINTENANCE AND CLEANING

Daily Cleaning

At the end of a working day, clean the equipment, both for hygienic reasons and to avoid malfunctioning.

The oven must never be cleaned using direct or high pressure water jets.

Never use pan-scrubbers, steel brushes, or scrapers or abrasive cleaners to clean the inside or outside of the oven.

Wait for the cooking compartment to cool down.

To clean the oven external parts, use a damp cloth and a non-aggressive cleaner.

Cleaning The Glass

The door window can be cleaned both on the outside and on the inside. To do this, turn the latch that locks the internal window in position in a clockwise direction and, once the window is open, clean it with a suitable detergent. Never use abrasive materials.

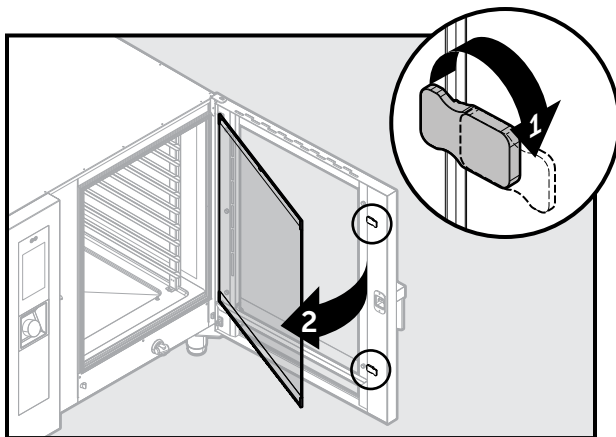

The glass should then be closed properly and locked in place by turning the relevant latch counterclockwise.

Humidity Discharge

The humidity discharge expels the vapors produced inside the cooking chamber.

Check that it is always perfectly clean and free from obstructions.

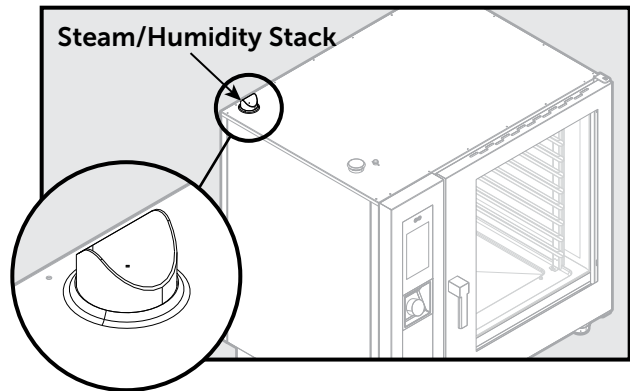

Cleaning—Control Panel Ventilation Filter

The oven control panel ventilation filter must be cleaned at least once a week by washing the filter by hand with soap and water. Depending on working environment, additional cleaning may be required.

To slide the filter out, pull downward and apply force on the relevant hand-hold.

It is good practice to replace the filter at least once a year or even more frequently whenever the oven operates in environments in which there is a high concentration of flours or similar substances.

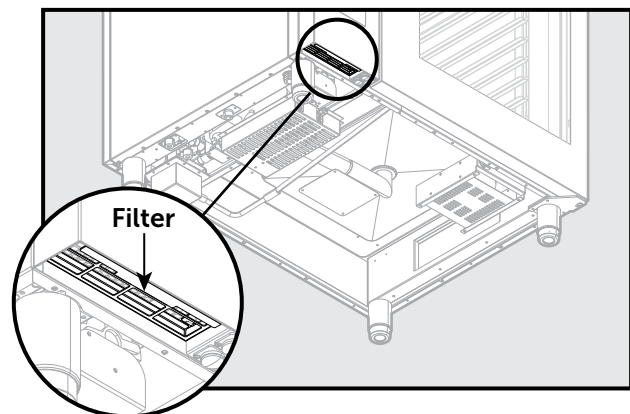

In all cases, the filter must be replaced when it is consumed or damaged; it must be requested from Giorik as a non-warranty part.

PRODUCT OVERVIEW

Name	Description	Action	Name
E01 - Chamber Probe	Compartment probe error	Cooking block, automatic restore.	Replace compartment probe.
E17 - Core Probe	Core probe error	Manual restore.	Replace core probe.
E05 - Motor Safety	Motor alarm	Cooking block, automatic re-set.	If continuous, contact service agency.
E03 - Inv	Motor Inverter alarm	Cooking block, automatic re-set.	If continuous, contact service agency.
E06 - Chamber Safety	Compartment safety high limit.	Cooking block, manual re-set.	If continuous, contact service agency
E07 - PWM	PWM board error (communication timeout or problems on fan speed)	Cooking block.	Contact service agency
E08 - PWM 2	PWM second board error (communication timeout or problems on fan speed)	Cooking block.	Contact service agency.
E14 E15 - Hi Temp	Control compartment temperature too high.	Cooking is blocked, automatic restore.	Check oven's perimeter ventilation (louvers) and the correct functioning of the cooling fans of the components. Clean Filter (see page 37).
E09 - Com PWM	PWM board communication error	Cooking block.	Remove power and then give back. If continuous, contact service agency
E10 - Com PWM2	PWM2 board communication error	Cooking block.	Remove power and then give back. If continuous, contact service agency
E16 - Communication	Main board communication error	Cooking block.	Remove power and then give back. If continuous, contact service agency
E22 - Power Fail	Electrical power failure	Cooking block.	Press master knob for 1 second.
E19 - Probe 4	Humidity control probe 4 alarm	Cooking block.	Replace humidity probe 4.
E20 - Probe 5	Humidity control probe 5 alarm	Cooking block.	Replace humidity probe 5.

PRODUCT OVERVIEW

Name	Description	Action	Name
E12 - Ignition Reset	Gas ignition is not detects	Cooking cycle block, manual reset.	Press manual restore. (encoder button); if the problem persists, contact the support centre.
E13 - Ignition Reset 2	Gas ignition is not detects on burner 2	Cooking cycle block, manual reset.	Press manual restore. (encoder button); if the problem persists, contact the support centre.
E04 - Air Flow	Air flow rate alarm on gas burner	Cooking cycle block, manual reset.	Check the obstructions of the combustion fumes exhaust chimney, otherwise contact the assistance centre.
E18 - Air Flow 2	Air flow rate alarm on second gas burner	Cooking cycle block, manual reset.	Check obstructions to the combustion fumes discharge chimney, otherwise contact after-sales assistance.
E21 - No water	There is no water to generate steam	Cooking cycle block; automatic reset.	Check the connection to water pipeline and make sure the shut-off valve is open.
E24 - No water litre-meter	Litre-meter, washing alarm	Washing block, manual restore	Press the manual restore (encoder button) If the problem persists, contact the support centre.
E23 - Boiler drain not completed	Boiler water did not drain correctly	Cooking block	Remove power and turn on. Check cleanliness and operation of boiler discharge valve. Check the boiler.



COMBI OVEN OPERATION MANUAL

GIORIK LIMITED WARRANTY

2 Year Standard Warranty—adjusted to 2 years

LIMITED WARRANTIES AND REMEDIES. Seller warrants that at the time of shipment the Products will be free from defects in material and workmanship for a period of no longer than TWO YEAR from the original installation by an authorized representative or no longer than TWO YEAR AND THREE MONTHS from the date of shipment from the factory. Defective conditions caused by abnormal use or misuse lack of or improper maintenance damage by third parties alterations by unauthorized personnel acts of God failure to follow installation and/or operating instructions or any other events beyond the reasonable control of the Seller will NOT be covered under this Warranty. The obligations of the Seller under this warranty shall be limited to repairing or replacing (at the option of the Seller) any part with the exception of lamps, fuses, door gaskets, and glass (which are not covered under this warranty) which is found defective in the reasonable opinion of the Seller. Any part found defective by the Seller will be repaired or replaced without charge F.O.B. authorized Giorik Distributor. Seller and/or its authorized representatives will assume the normal replacement labor expense for the defective part for the period of the warranty as stated above including reasonable (up to 100 mile or 2 hr round trip) travel time where replacement work is performed during standard business hours and not subject to overtime holiday rates and/or any additional fees. IN NO EVENT SHALL THE SELLER BE LIABLE FOR LOSS OF USE LOSS OF REVENUE OR LOSS OF PRODUCT OR PROFIT OR FOR INDIRECT INCIDENTAL SPECIAL OR CONSEQUENTIAL DAMAGES INCLUDING BUT NOT LIMITED TO FOOD SPOILAGE OR PRODUCT LOSS. THIS WARRANTY DOES NOT COVER GLASS BREAKAGE. THE ABOVE WARRANTY IS EXCLUSIVE AND ALL OTHER WARRANTIES EXPRESS OR IMPLIED ARE EXCLUDED INCLUDING THE IMPLIED WARRANTIES OF MERCHANTABILITY AND FITNESS FOR A PARTICULAR PURPOSE. Any appliance replacement part (with the exception of lamps, fuses, gaskets and glass) which proves to be defective in material or workmanship within ninety (90) days of installation will be replaced without charge F.O.B. authorized Giorik Distributor. The user shall have the responsibility and expense of removing and returning the defective part to the Seller as well as the cost of reinstalling the replacement or repaired part.

Notes