



# INSTALLATION AND OPERATION MANUAL

## GARLAND INDUCTION TEMPERATURE CONTROLLED BUILT-IN HOLD-LINE

with **RTCSmp TECHNOLOGY**  
Real-time Temperature Control System  
multi-point sensing



**CE models** comply with the latest European Norms: EN 60335-1, EN 60335-2-36, EN 62233 (EMC/EMV)

**North American models:** ETL listed in compliance with UL 197, CSA C22.2 No.109, NSF-4  
Complies with FCC part 18, ICES-001

### WARNING

**IMPROPER INSTALLATION, ADJUSTMENT, ALTERATION, SERVICE OR MAINTENANCE CAN CAUSE PROPERTY DAMAGE, INJURY, OR DEATH. READ THE INSTALLATION, OPERATING AND MAINTENANCE INSTRUCTIONS THOROUGHLY BEFORE INSTALLING OR SERVICING THIS EQUIPMENT**

Users are cautioned that maintenance and repairs must be performed by a Garland authorized service agent using only genuine Garland replacement parts. Garland will have no obligation with respect to any product that has been improperly installed, adjusted, operated or not maintained in accordance with national and local codes and/or installation instructions provided with the product or any product that has its serial number defaced, obliterated or removed, and/or which has been modified or repaired using unauthorized parts or by unauthorized service agents. For a list of authorized service agents and/or genuine replacement parts, please visit our website at [www.garland-group.com](http://www.garland-group.com) for USA and Canada. For international customers, please visit [www.manitowocfoodservice.com](http://www.manitowocfoodservice.com). The information contained herein, including design and part specifications, may be superseded and is subject to change without notice.



**Models:**  
**HO IN 450/ 900/ 350/ 1800**



PLEASE READ ALL SECTIONS OF THIS MANUAL AND RETAIN FOR FUTURE REFERENCE.

THIS PRODUCT HAS BEEN CERTIFIED AS COMMERCIAL COOKING EQUIPMENT AND MUST BE INSTALLED BY PROFESSIONAL PERSONNEL AS SPECIFIED

INSTALLATION AND ELECTRICAL CONNECTION MUST COMPLY WITH CURRENT CODES:  
IN CANADA – THE CANADIAN ELECTRICAL CODE PART 1 AND / OR LOCAL CODES.  
IN USA – THE NATIONAL ELECTRICAL CODE ANSI / NFPA – CURRENT EDITION.

### FOR YOUR SAFETY

**DO NOT STORE OR USE GASOLINE OR OTHER FLAMMABLE VAPORS OR LIQUIDS IN THE VICINITY OF THIS OR ANY OTHER APPLIANCE**



Visit our **Video Gallery** at [www.Garland-Group.com](http://www.Garland-Group.com)



## WARRANTY

Our warranty statements for induction products are available on-line. Please visit our website at [www.garland-group.com/minisite/service](http://www.garland-group.com/minisite/service) to download the latest revision. If you might have any questions, please contact Garland.

## UNPACKING and PACKING SLIP







The packing slip attached to the shipment contains detailed information of all components. Please retain this packing slip for future reference.

## USING THIS MANUAL

This manual contains important information regarding safety, installation, operation, maintenance, and troubleshooting. They must be read entirely and carefully by the installers and operators before the equipment is installed and taken into operation. This manual must always be available for reference at the place of operation.

Throughout this manual, the induction unit type "RTCSmp Heat Retaining Hold-Line" is referred to as "induction unit".

## DESCRIPTION OF WARNING SYMBOLS

	This symbol alerts you to a hazardous situation that WILL or COULD cause serious bodily harm or death. Be alert and implement relevant safety precautions.		
	This dangerous voltage warning symbol indicates a risk of electric shock and hazards from dangerous voltage.		
<b>CAUTION</b>	This symbol alerts a hazardous situation, which if not avoided, COULD cause minor to moderate personal injury or property damage. The relevant safety precautions MUST be implemented at all times.		
	Electromagnetic field.		
	<table border="1" style="width: 100%; text-align: center;"> <tr> <td data-bbox="418 1318 891 1434"> <p><b>Warning</b>                      Risk of fire or electric shock                      Do not open</p> </td> <td data-bbox="891 1318 1222 1434">  </td> </tr> </table> <p>To reduce the risk of fire or electric shock, do not remove or open cover.                      No user serviceable parts inside.                      Refer servicing to qualified personnel.</p>	<p><b>Warning</b>                      Risk of fire or electric shock                      Do not open</p>	
<p><b>Warning</b>                      Risk of fire or electric shock                      Do not open</p>			

## CONTACTS

Garland Commercial Ranges Ltd. | 1177 Kamato Road, Mississauga, Ontario, Canada. L4W 1X4  
 T: 1-905-624-0260 | F: 1-905-624-5669 | [www.garland-group.com](http://www.garland-group.com)

USA Sales, Parts and Service    1-800-424-2411  
 Canadian Sales    1-888-442-7526  
 Canada or USA Parts/Service    1-800-427-6668  
 International Sales and Service    [www.ManitowocFoodservice.com](http://www.ManitowocFoodservice.com)

<b>WARRANTY .....</b>	<b>2</b>
<b>UNPACKING and PACKING SLIP .....</b>	<b>2</b>
<b>USING THIS MANUAL .....</b>	<b>2</b>
<b>DESCRIPTION OF WARNING SYMBOLS.....</b>	<b>2</b>
<b>CONTACTS.....</b>	<b>2</b>
<b>1 Safety Requirements.....</b>	<b>4</b>
1.1 Risk Involved By Disregarding Safety Information.....	4
1.2 Safety Instructions for Operator .....	4
1.3 Improper Use of the Equipment.....	5
1.4 Unauthorized Modification and Use of Spare Parts.....	5
1.5 Pan Detection.....	5
<b>2 Components and Features.....</b>	<b>6</b>
2.1 Application.....	6
2.1 Components and Features .....	6
<b>3 Dimensions and Technical Specifications .....</b>	<b>7</b>
3.1 Rating Plate.....	7
3.2 Nomenclature and Models .....	7
3.3 Dimensions .....	7
3.4 Electrical Specifications .....	7
3.5 Operating Conditions.....	7
3.6 Compliances .....	7
<b>4 Installation .....</b>	<b>8</b>
4.1 Location.....	8
4.2 Ventilation .....	8
4.3 Electrical Compartment Protection.....	9
4.4 Configurations .....	10
4.5 Dimensions and Installation.....	11
4.5.1 Heat Retaining Plate Installation .....	11
4.5.1.1 Dimensions: RTCSmp HOIN450/900/1350/1800 Heat Retaining Plate	11
4.5.1.2 Cut-Out Dimensions	11
4.5.1.3 Parallel Installation and Clearance	12
4.5.1.4 Installation Steps	13
4.5.2 Control Unit Installation .....	14
4.5.2.1 Dimensions: Control Unit RTCSmp HOIN450/900/1350/1800	14
4.5.2.2 Front-Mount	15
4.5.2.3 Back-Mount	15
4.5.3 Induction Generator Installation .....	15
4.5.3.1 Orientation	16
4.5.3.2 Mounting Methods	16
4.5.3.3 Dimensions: Induction Generator RTCSmp HOIN450/900/1350/1800	16
4.6 Electrical Installation .....	17
<b>5 Function Test .....</b>	<b>19</b>
<b>6 Operating Instructions.....</b>	<b>20</b>
6.1 Proper Induction Chafing Dish or Pan .....	20
6.2 Proper Placement of Chafing Dish or Pan on Single Hob.....	21
6.3 Temperature Control and Display.....	22
6.3.1 Configurations and Temperature Control .....	22
6.3.2 Set and Current Temperatures.....	23
6.3.3 Digital Display.....	23
6.4 No Pan No Heat .....	23
6.5 When Unit is Not In Use .....	23
<b>7 Cleaning.....</b>	<b>24</b>
<b>8 Maintenance .....</b>	<b>25</b>
<b>9 Important Rules .....</b>	<b>25</b>
<b>10 Troubleshooting.....</b>	<b>26</b>
10.1 Common causes for induction unit failure .....	26
10.2 Problems and Possible Causes .....	27
10.3 Troubleshooting with Error Codes (for Service Technicians) .....	28

# 1 Safety Requirements

**WARNING**

This product contains chemicals known to the State of California to cause cancer. Installation and servicing of this product could expose you to airborne particles of glass wool / ceramic fibers. Inhalation of airborne particles of glass wool / ceramic fibers is known to the State of California to cause cancer.

**IMPORTANT**

Warning labels mounted directly on the induction unit must be observed at all times and kept in a fully legible condition.

**IMPORTANT**

To ensure your working environment is safe, you must follow all of the safety instructions contained in this manual, the existing national regulations for accident prevention with electrical systems, as well as any relevant company-specific safety instructions.



The induction unit should only be used if and only if the installation of the electrical system is fitted by an approved installation contractor in accordance with specific national and local regulations.

## 1.1 Risk Involved By Disregarding Safety Information

Disregarding the safety instructions may cause harm to people, the surroundings, and the induction unit. Garland is not responsible for any damages or personal injury caused by failure to observe the safety requirements. Risks involved when disregarding safety precautions may include:

- Death or injury caused by electric shock.
- Injury due to burns from contacting overheated chafing dish or pan or glass-top.
- Damage to the induction unit caused by using unsuitable chafing dish or pan.

## 1.2 Safety Instructions for Operator

Please follow the following rules to avoid personal injuries and property damages:

- When the unit is in use, heat transfers from the cookware to the glass-top; the glass-top can become hot. To avoid burn injuries, do not touch the heating area when the unit is in use.
- If the glass-top is cracked or broken, switch off the induction unit immediately and if possible and safe, disconnect it from the power supply. Do not touch any parts inside the induction unit.
- Persons with a cardiac pacemaker should consult their doctor whether they are safe near an induction unit.
- If the power cord is damaged, have it replaced immediately by an approved service technician.
- The induction unit heats up cookware quickly. Do not leave an empty pan on the unit and do not leave the unit unattended during operation.
- Do not put any other items on the glass cook-top except non-empty induction chafing dish or pan.
  - Do not leave any object such as paper, cardboard, or cloth between the cookware and the cooking surface, as this might start a fire.

- Metallic objects are heated up very quickly when placed on the induction unit when the unit is in use. Do not place any objects such as closed cans, aluminum foil, cutlery, jewelry, or watches on the induction unit.
- Do not place credit cards, phone cards, tapes, or any objects sensitive to magnetism on the cooking surface.
- Do not place plastic vessels and aluminum objects such as aluminum foil on the glass-top.
- Ensure liquid cannot enter into the induction unit. Do not let water or food overflow the cooking area. Do not use hoses to clean or power wash the induction unit or its vicinity.
- The induction unit has an internal air-cooling system. Do not block the air intake and exhaust openings with objects such as cleaning cloths or containers. Any obstruction to the air intake and exhaust could cause the unit to overheat and to switch off.
- Switch the unit OFF if you take the chafing dish or pan away for a while. This will prevent the heating process to start automatically and unintentionally when a pan is placed back on the heating area. If any person needs to use the induction unit, he/she will have to turn the unit ON intentionally.
- Use only induction suitable chafing dishes or pans with proper sizes and made of proper material. The induction suitable serving dishes or pans should also be in good condition without any uneven, arched or partially detached bottoms.

### 1.3 Improper Use of the Equipment

The reliability of the induction unit can only be guaranteed when it is used properly. The induction unit must always be operated within the limits provided in the technical specifications. Please refer to section **9 Important Rules** of using induction equipment.

### 1.4 Unauthorized Modification and Use of Spare Parts

Please contact the manufacturer if you intend to make any changes on the induction unit. For safety reasons, always use genuine parts and accessories approved by Garland. Any unauthorized modification as well as any installation of unapproved components will void all warranty. See **Warranty**, p.2.

### 1.5 Pan Detection

Energy is transferred to cookware when the induction system detects a suitable pan on the heating area. The digital display signals to communicate the Pan Detection process.

- When the unit is ON without any pan on the hob, the display shows the current temperature without a dot; the unit is in pan detection mode.
- As soon as a pan is put on the hob, the heating process is engaged and the display shows the current temperature followed by a blinking dot.
- However, if the unit is not detecting any pan, the current temperature is shown without a dot.

**NOTE:** Pan with a bottom diameter smaller than 5" (12 cm) is not detected by the system.

## 2 Components and Features

### 2.1 Application

The RTCSmp Install Hold-Line units are specially designed as built-in equipment for closed counters. These units are ideal for buffets, events and banqueting, providing constant and precise temperature to ensure top quality food presentations and appeal. The RTCSmp Install Hold-Line model offers four configuration options; a single generator can power up to four hotplates. Temperature adjustment within a large temperature range (122-212°F / 50-100°C) allows for flexibility and precise food temperature requirements. To guarantee the induction units' reliability and performance, please observe all safety, installation, and operation requirements mentioned in this manual.

### 2.1 Components and Features



Built with a robust construction, the RTCSmp Induction Hold-Line unit is modular and powerful with the revolutionary RTCSmp-Technology (Realtime Temperature Control System with Multi-Point sensing). The RTCSmp Technology monitors the energy supply, the state of the induction coil, power board, CPU, and the cooking zone in realtime. RTCSmp also limits the energy supply during peak load and its special control eliminates interference noises.

The RTCSmp Hold-Line models include a number of components which allow for optimal flexibility in designing an efficient kitchen. The unique features of each component are outlined below. See also chapter **3 Dimensions and Technical Specifications**.

#### Induction Generator:



Engineered specifically for heat retaining applications. | All connections are accessible from the front of the housing. | Closed aluminum housing with integrated cooling fan to keep electronics cool. | Integrated air guiding system to direct exhaust air out of the housing on its left and right sides.

#### Heat Retaining Plate:



Compact and flat profile to allow for flush mounted installations in shallow cabinets. | High impact Ceran glass-top with a highly visible digital display beneath to show the set and the current temperatures. | Included: Coil and Sensor Cables.

#### Operation Unit:



Each control switch consists of a chrome sheet metal cover with a built-in power switch, enclosed in a strong, polymer housing. | Control units are separately mounted; each comes with a 118" (3000mm) RJ-45 cable. | The control unit regulates the temperature in an increment of 5°F(1°C), from 122-212°F / 50-100°C. | Simple to operate. Adjust the temperature setting simply by turning the knob.

## 3 Dimensions and Technical Specifications

### 3.1 Rating Plate

The rating plate specifies important information such as model number, serial number, and electrical specifications. The rating plate is affixed to the bottom of the generator, by the connectors at the front.

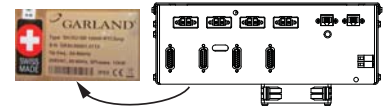

### 3.2 Nomenclature and Models

Series	Built-In	Power (Watt)	Model
HO = Hold Line	IN	450 (1 heat-retaining plate)	HO IN 450
		900 (2 heat-retaining plates)	HO IN 900
		1350 (3 heat-retaining plates)	HO IN 1350
		1800 (4 heat-retaining plates)	HO IN 1800

### 3.3 Dimensions

Component	Dimensions (width x length x height)
Generator Housing	11.93"x 12.28"x 5.31" (303 x 312 x 135mm)
Heat-Retaining Plate	12.68"x 12.68"x 2.95" (322 x 322 x 75 mm)
Ceran Glass	12.68"x 12.68"x 0.16" (322 x 322 x 4 mm)

### 3.4 Electrical Specifications

Model	Voltage	Power	Power Per Heating Plate
HOIN450/900/1350/1800	120 V AC / 1Ph	1800 W / 16A	450W
HOIN450/900/1350/1800	230 V AC / 1Ph	1800 W / 8A	450W

### 3.5 Operating Conditions

Max. Tolerance of Nominal Supply Voltage	+6 /-10 %
Supply frequency	50/60 Hz
Ingress Protection class	IP X0
Minimal Diameter of Induction Pan	5" (12cm)
Maximum Ambient Temperature	In Storage > -4°F to +158°F (-20°C to +70°C) In Operation >+ 41°F to +104°F (+5°C to +40°C)
Maximum Relative Air Humidity	In Storage > 10% to 90% In Operation > 30% to 90%
Set Temperature Range	122-212°F / 50-100°C
Maximum air flow: 56.50cfm / 96m <sup>3</sup> per hour and min. opening: 9.30 sq.in. / 6000mm <sup>2</sup> is required.	

### 3.6 Compliances

- **North American models:**  
ETL listed in compliance with UL 197, CSA C22.2 No.109, NSF-4. Complies with FCC part 18, ICES-001
- **CE models** comply with the latest European Norms:  
EN 60335-1, EN 60335-2-36, EN 62233 (EMC/EMV)

## 4 Installation

### IMPORTANT

- Kitchen designers and installation contractors are responsible for designing and installing correctly the appropriate support structures and ventilation system for the cooking equipment.
- When designing kitchen cabinets for the induction equipment, please take into account all installation requirements, including factors such as: ease of electrical installation, size of the power conductor, and length of the wires.
- The installation, including electrical installation, must be carried out by registered installation contractors only. The contractors are responsible for interpreting all instructions correctly and performing the installation in compliance with national and local regulations. The warning signs and rating plates on the cooking equipment must strictly be followed.
- Read ALL SECTIONS carefully, comply with all requirements listed and ensure all inspection is done by qualified personnel.
- Refer to the technical data given in chapter **3 Dimensions and Technical Specifications**.
- **Induction equipment that is not installed correctly will have warranty voided. See Warranty, p.2.**

### 4.1 Location

- The induction unit must be installed securely in closed counters. **IMPORTANT:** Allow easy access to unit and cable connections for maintenance and service.
- The heat retaining plate has to be mounted on a leveled and even counter surface.
- The generator can be placed in a separate cabinet. All the connectors are located at the front. **CLEARANCE** minimum 2.95”(75mm) for the connectors. Ensure the generator and connectors can be accessed easily for electrical installation and service.
- Do not place the induction unit on or near a hot surface or any heat producing equipment such as an oven or a deep fryer.
- Protect the induction unit from steam if the unit is placed next to high steam emitting equipment such as pasta cookers, steamers, and water bath.
- Allow easy access to the control knob(s).
- Keep the induction unit away from combustible materials, vapors or liquids.

### 4.2 Ventilation

Proper cool air intake and ventilation is essential to the reliability and functioning of the induction unit. Please ensure all requirements listed below are met:

- The air intake and exhaust openings of the Generator must not be blocked. **CLEARANCE:** minimum 1.57” (40mm).
- The maximum air flow is 56.50cfm (96m<sup>3</sup> per hour) and therefore a minimal opening of 9.30 sq.in. (6000 mm<sup>2</sup>) is required.
- An optimal air intake must not be restricted by the installation.

- Ensure the induction unit always gets cool air intake. If necessary, draw in fresh air supply through an air duct (not provided).
- When installing the built-in unit, ensure the intake air and exhaust air are conducted separately. The intake air and exhaust air must not mix. To avoid build-up of hot exhaust air inside the cabinet, draw the exhaust air out of the cabinet. Build up of hot exhaust air will cause the induction unit to reduce power or to switch-off. The air intake temperature must not exceed 104°F (40°C).
- We recommend drawing fresh intake air through an air intake vent with a removable air intake filter.
- It is highly recommended that an exhaust fan be installed into the cabinet at an appropriate location. This will force hot air out the cabinet and away from the induction unit. Consult an electrical or installation expert for the most appropriate location to install a cabinet exhaust fan.

### 4.3 Electrical Compartment Protection

To protect the equipment, isolate the unit and the wires in a separate electrical compartment inside the cabinet. The illustrations below show two installation versions.

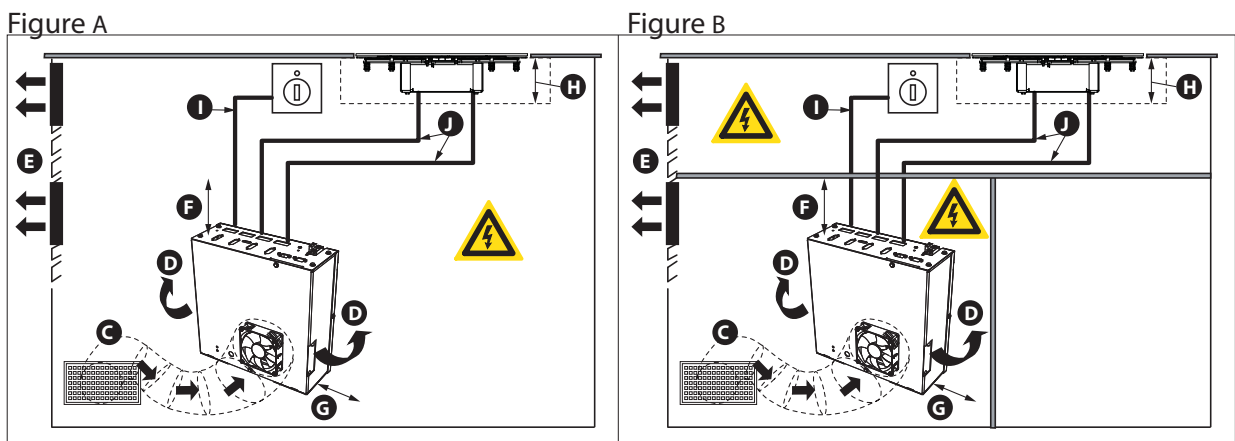

Figure (A) The unit is installed in one compartment and the wires are exposed.

Figure (B) The interior space of the cabinet is divided and the unit and the wires are protected inside separate compartments. Extra storage space is also created next to the electrical compartments.

- (C) **IMPORTANT** Fresh air intake through the fan. It is recommended to isolate the fresh air intake from the exhaust air via an air intake duct and filter the intake air with a removable air filter. (see example on right)
- (D) Hot air exhaust from the induction unit.
- (E) **IMPORTANT** Air exhaust opening installed on the cabinet. It is highly recommended to install a fan or fans on the cabinet to pull the hot exhaust air away from the electronic equipment. Buildup of hot exhaust air will cause the induction unit to reduce power or to switch-off. The air intake temperature must not exceed 40°C / 104°F.
- (F) **IMPORTANT** **Minimum clearance for electrical connections: 75mm / 2.95"**
- (G) **IMPORTANT** **Minimum clearance for air-exhaust outlets: 40mm / 1.57"**



(H) **IMPORTANT** Minimum clearance for heat plate under counter surface: 100mm / 3.94"

(I) Cable for operation unit connecting to the induction generator, MAX 300cm / 118".

(J) Cables for coil and sensors.

**IMPORTANT** Always route sensor and communication cables separately and away from the coil cables.

## 4.4 Configurations

One Induction Generator can power up to four (4) Heat Retaining Plates. You need to install two (2) control units for any configurations with 2 to 4 Heat Retaining Plates.

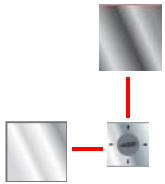
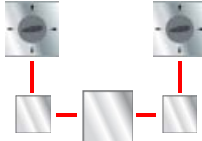
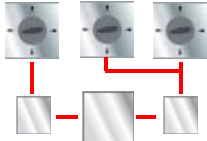
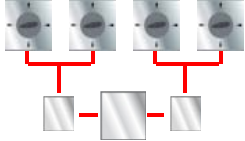
Model	Configuration (Heat Retaining Plate(s), Control Switch(s), and Induction Generator are shown)	
HO IN 450		<p>One switch controls one heat retaining plate.</p> <p>One (1) heat retaining plate, one (1) generator and one (1) control unit.</p>
HO IN 900		<p>Two switches; each controls only one heat retaining plate.</p> <p>Two (2) heat retaining plate, one (1) generator and two (2) control units.</p>
HO IN 1350		<p>Two switches; one switch controls one heat retaining plate and the other switch controls two plates.</p> <p>Three (3) heat retaining plate, one (1) generator and two (2) control units.</p>
HO IN 1800		<p>Two switches; each controls two heat retaining plates.</p> <p>Four (4) heat retaining plate, one (1) generator and two (2) control units.</p>

## 4.5 Dimensions and Installation

### 4.5.1 Heat Retaining Plate Installation

The Heat Retaining Plate is to be flush-mounted. A support frame or support structure has to be custom designed and built for housing the retaining plate(s).

#### 4.5.1.1 Dimensions: RTCSmp HOIN450/900/1350/1800 Heat Retaining Plate (measurements in mm and [inch])

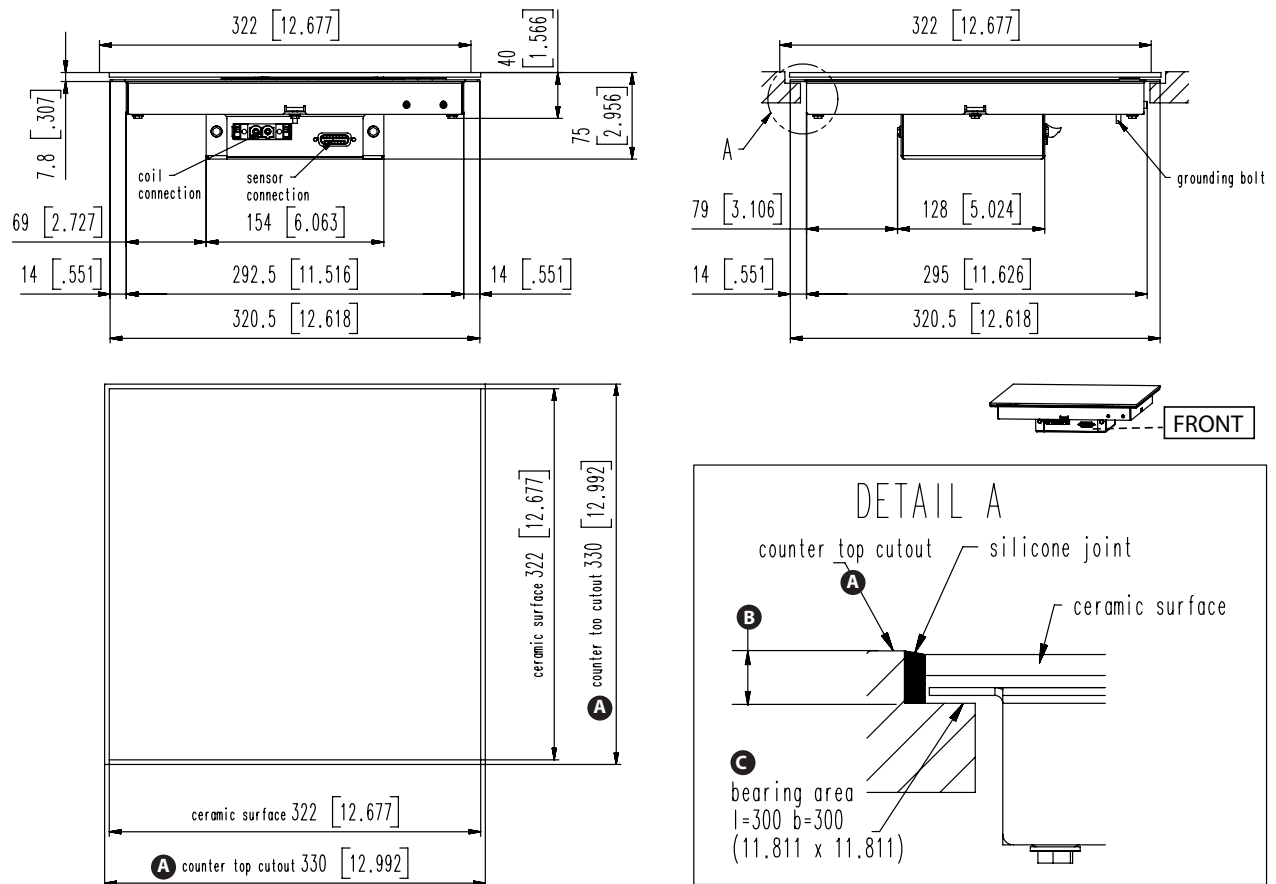

#### 4.5.1.2 Cut-Out Dimensions

- Please review carefully the dimensions in section **4.5.1.1**.
- Refer to **Detail A** in section **4.5.1.1**:
  - A.** Cut-out dimension on the counter surface: 330 x 330mm [12.99" x 12.99"].
 

**NOTE:** Dimensions include widths for silicone joints on all four (4) sides.

Consider adjusting cutout dimensions based on mounting methods, see 4.5.1.3.
  - B.** Recommended recess depth: minimum 8.00 to 8.64mm [0.315" to 0.34"].
  - C.** Body Clearance (width x depth x height): 300 x 300 x 100mm / 11.81" x 11.81" x 3.94".

### 4.5.1.3 Parallel Installation and Clearance

**NOTE:** The information provided below can only be used as a general guideline. Designers must consult their countertop suppliers when designing the appropriate support structure and clearance for the countertop and the installation.

- **Countertop Material and Spacing Requirement**

For structural strength and protection against water penetration, we recommend the followings:

- For stone countertop, keep a minimum gap of 4" [101.6mm] between cut-outs and provide reinforcement beam in-between units.
- For other countertop materials, the glass-tops can be put side by side, and the joints between glass-tops must be sealed with silicone to ensure the installation is water-tight.

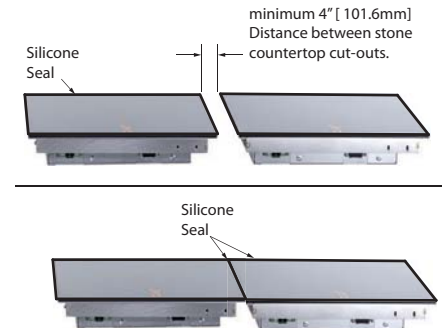

- A 4mm gap between glass-tops for silicone is recommended (Option 1). However, if no gap is desired for the installation, silicone sealant should be applied underneath the joint (Option 2). Ensure all NSF 4 requirements for food safety are met. (HO IN 3200 Heat Plates shown as an example.)

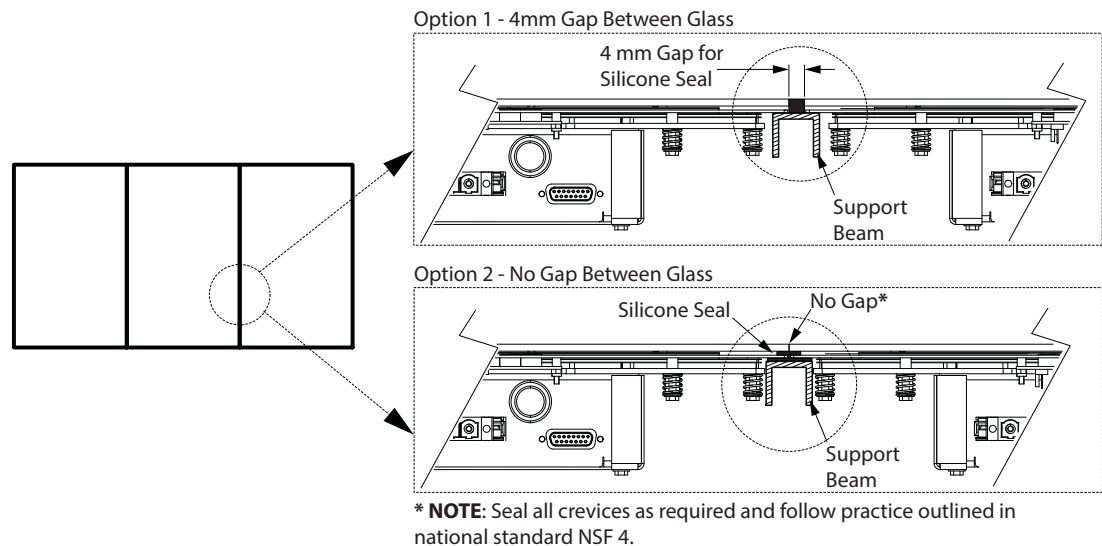

- **Heat Plates Configuration and Spacing Requirement**

The Heat Retaining Plates can be installed in a variety of arrangements. Some examples are:

- (A), (B), (C), and (D): The plates are placed in a row or in a square, with gaps or without gaps.
- (E) and (F): When installing two or more HO-IN units (each with one or more Heat Retaining Plates), a minimum gap of 75.0mm/ 2.95" between the edges of glass is required in between the groups of Heating Plates. (HO IN 3200 Heat Plates shown as an example.)

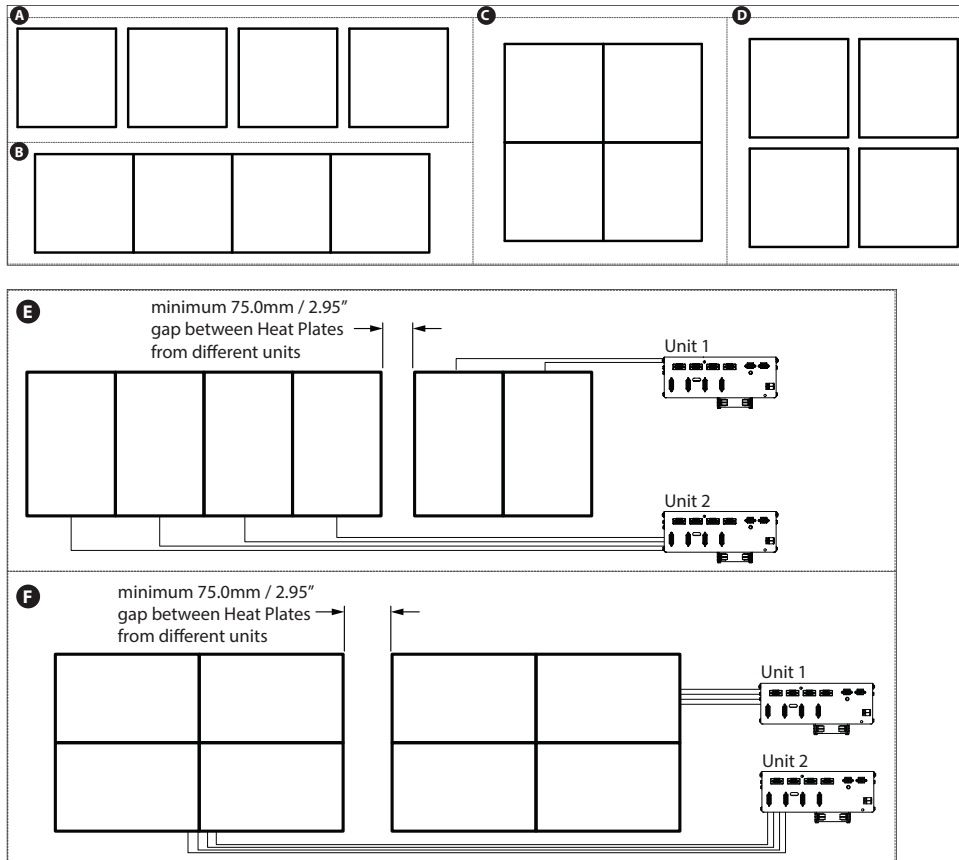

4.5.1.4 Installation Steps

**NOTE** Please pay attention to the orientation of the unit.

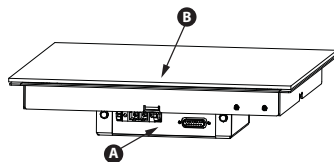

- A. The connectors are located at the FRONT of the unit.
- B. The digital temperature display underneath the Ceran glass is located at the CENTER FRONT of the unit.

**IMPORTANT** To protect the induction unit from water penetration, you must apply and bond the silicone adhesive properly to create a water-tight seal. Before you begin the installation, it is very important to use isopropyl alcohol (minimum 70%) or equivalent to clean the flange and the counter surfaces where the silicone adhesive will be applied.

**To install the Heat Retaining Plate:**

1. Apply dots of silicone adhesive PACTAN (not provide) all around the top of the step. This allows for leveling the unit. (PACTAN part number = 70000015.)
2. Carefully lower the Heat Retaining Plate into the opening.

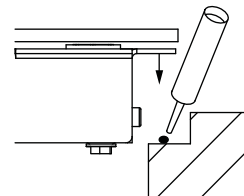

3. Center the unit within the cut-out.
4. Level and press the flange into the silicone at the same time. Ensure both the countertop and the hob(s) are leveled.
5. To provide a water tight seal, apply silicone adhesive completely around, filling any gaps between the unit and the counter-top surface. Carefully wipe up any excess silicone.

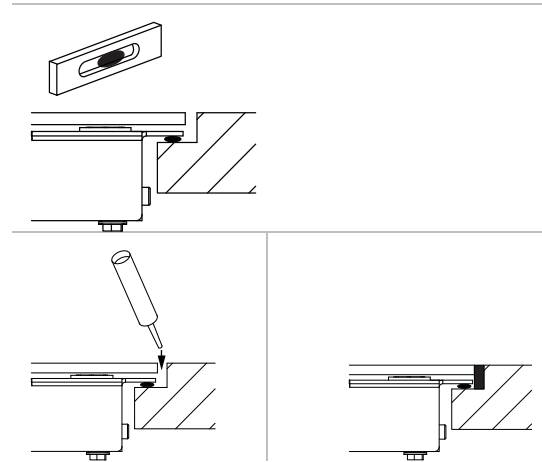

### 4.5.2 Control Unit Installation

The induction unit comes with up to two complete control units. The cable provided for each control is 118" (3000mm) long. There are No Green Indicator Lights on the control units for the RTCSmp Hold-Line models.

**NOTE** Install the control units **VERTICALLY** on the cabinet panel. There are two methods to install a control unit: front-mount or back-mount onto the panel. Installers are responsible for choosing the appropriate fasteners for the installation.

#### 4.5.2.1 Dimensions: Control Unit RTCSmp HOIN450/900/1350/1800

(Measurements in mm and [inch]. CAN/BUS denotes the potentiometer connection.)

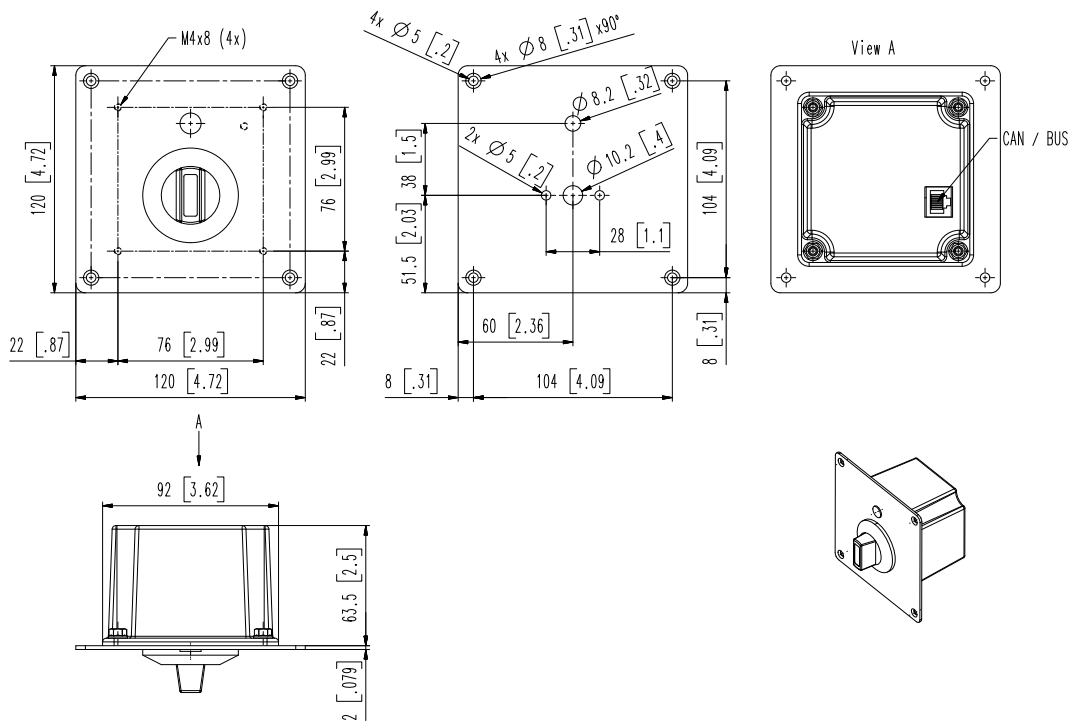

### 4.5.2.2 Front-Mount

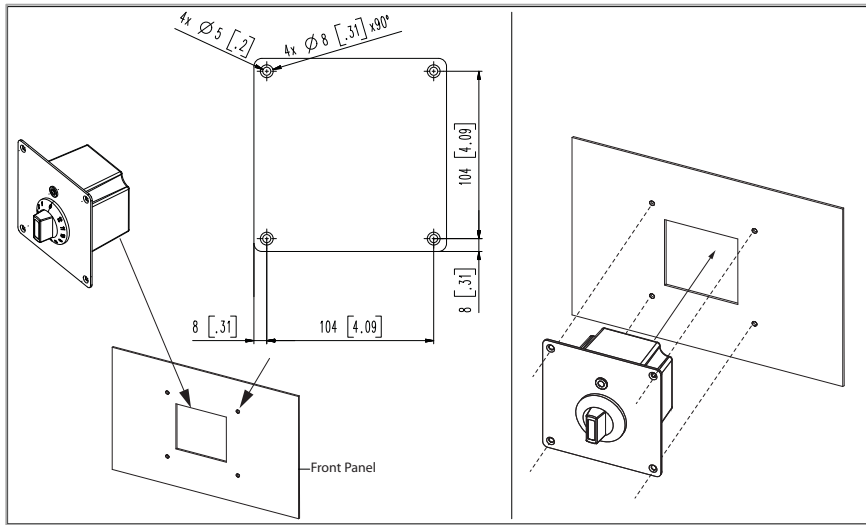

#### To mount the control unit onto the front of the panel:

1. Drill holes and make the cut-out using the dimensions and the actual unit provided.
2. Secure the control unit to the panel with fasteners.

Illustration: Measurements in mm and [inch].

### 4.5.2.3 Back-Mount

**NOTE** For this type of installation, the maximum thickness of the panel must not exceed 3mm or 12 gauge. This restriction ensures a proper grip on the knob.

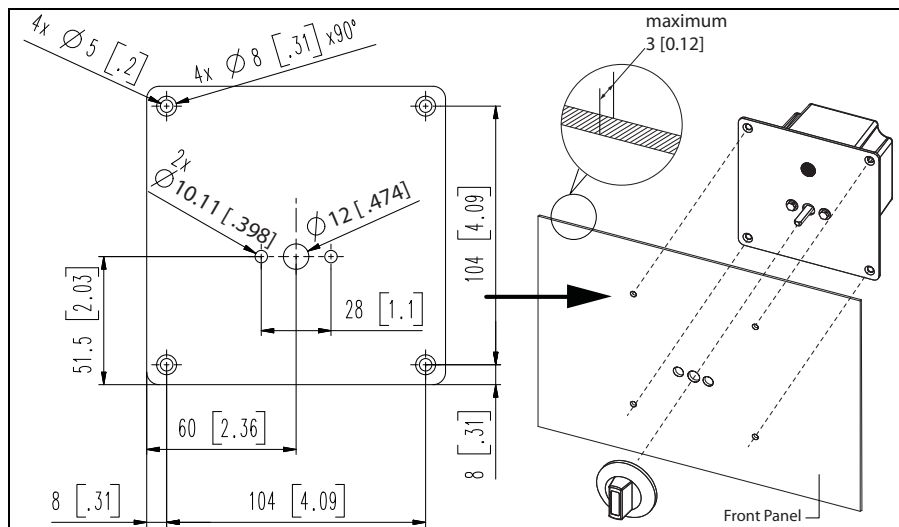

#### To mount the control unit from the back of the panel:

1. Drill holes on the panel using the dimensions provided.
2. Remove the plastic knob from the control unit and attach the control unit to the panel with fasteners as shown. **NOTE: DO NOT remove or loosen any screws on the control unit.**

Illustration: Measurements in mm and [inch].

## 4.5.3 Induction Generator Installation

### IMPORTANT

- All connectors are located at the FRONT of the Generator.
- **CLEARANCE** minimum 2.95"(75mm) in front of the connectors.
- Ensure the generator and connectors can be accessed easily for electrical installation and service.
- **CLEARANCE** minimum 1.57" (40mm) in front of the air-intake/exhaust outlets.

**4.5.3.1 Orientation**

The generator can be mounted in any orientation.

**IMPORTANT:** Consideration must be given to electrical connections, cooling (fresh air intake and exhaust) and service access.

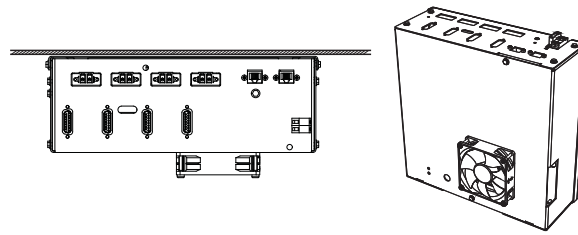

**4.5.3.2 Mounting Methods**

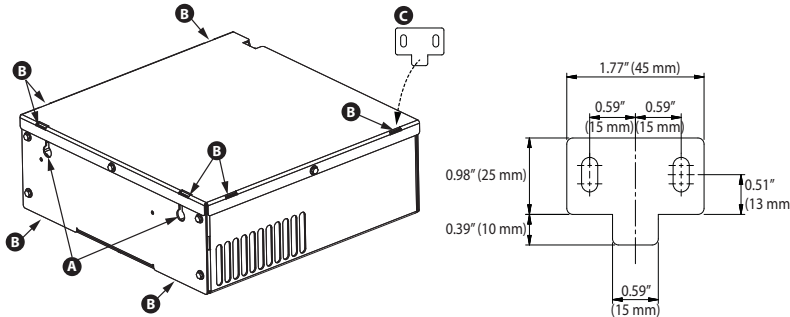

To install, use the holes (A) and/or the mounting brackets (C).

- (A) There are two holes on the back for installation.
- (B) Slots for inserting the mounting brackets.
- (C) Mounting brackets (provided).

**4.5.3.3 Dimensions: Induction Generator RTCSmp HOIN450/900/1350/1800**

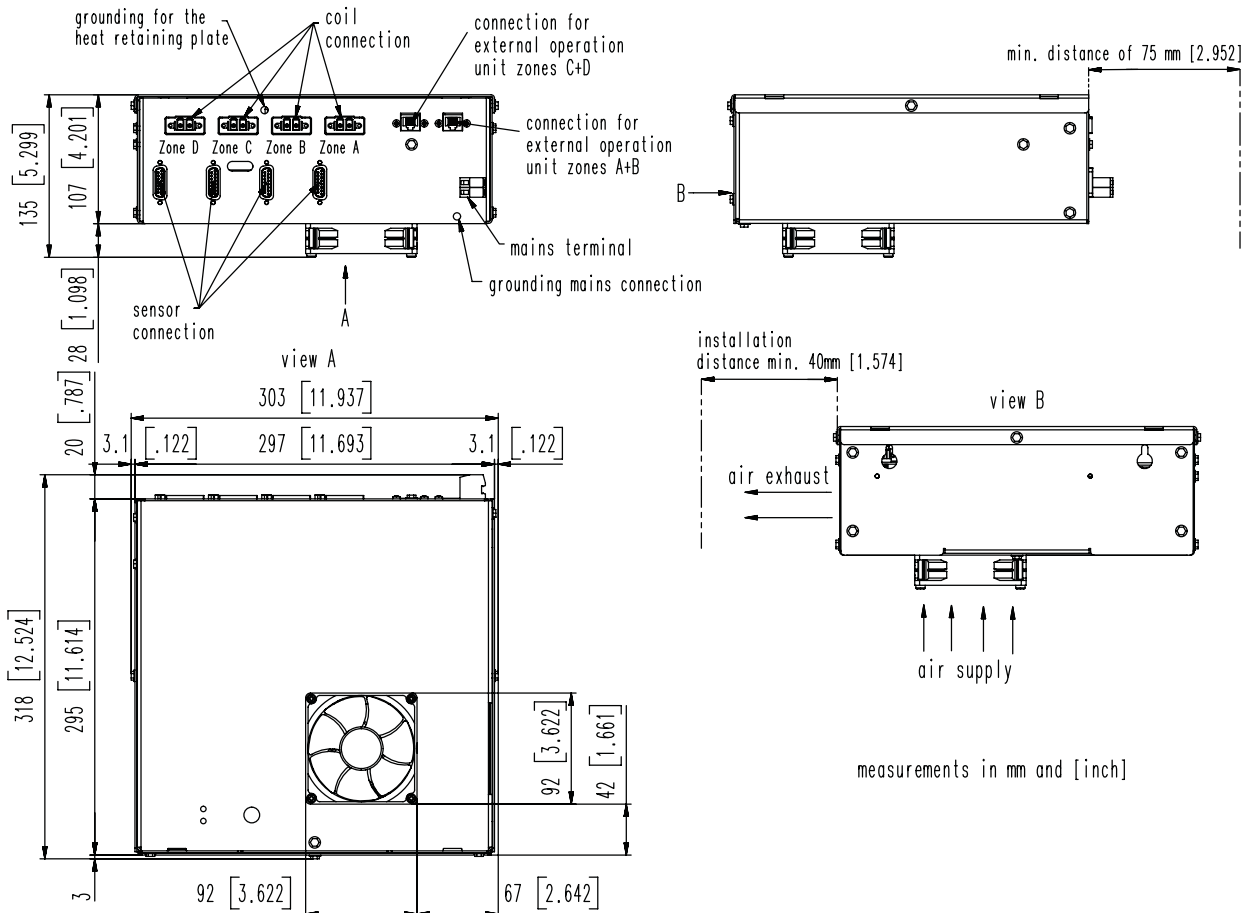

## 4.6 Electrical Installation

### IMPORTANT

- Refer to the electrical specifications in chapter **3 Dimensions and Technical Specifications AND the markings/instruction labels on the unit**. If the information differs between the data listed in the manual and the markings on the unit, always follow the markings on the unit.
- Check and ensure that the supply voltage and the line current match the specifications given on the rating plate. A stable mains supply must be provided.

#### CAUTION

Wrong voltage will damage the induction unit. Follow strictly the specifications on the rating plate.

- The electrical connections must satisfy the national and local electrical codes.
- If ground fault current protective switches are used, they must be provided with selective activation and designed for a minimum fault current of 30mA. Multiple generators with a mains connection must not be connected to a single fault current protective switch.
- Always route sensor and communication cables separately and away from the coil cables.
- To manage electromagnetic interference, excess cable length can be dressed and tied in a serpentine or S pattern, NOT coiled.

#### To setup the unit for operation:

1. Ensure the control knob is at the OFF-Position.

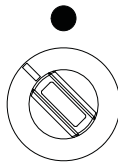

#### ON-Position

Any position where "0" / Line is not pointing straight up.

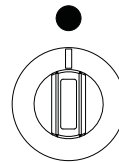

#### OFF-Position

"0" / Line is pointing straight up.

2. Remove all objects from the glass-top and check that the glass-top is neither cracked nor broken.

#### CAUTION

Do not continue if the glass-top is cracked or broken. Contact an authorized service agency for assistance.

## 3. Connecting the components:

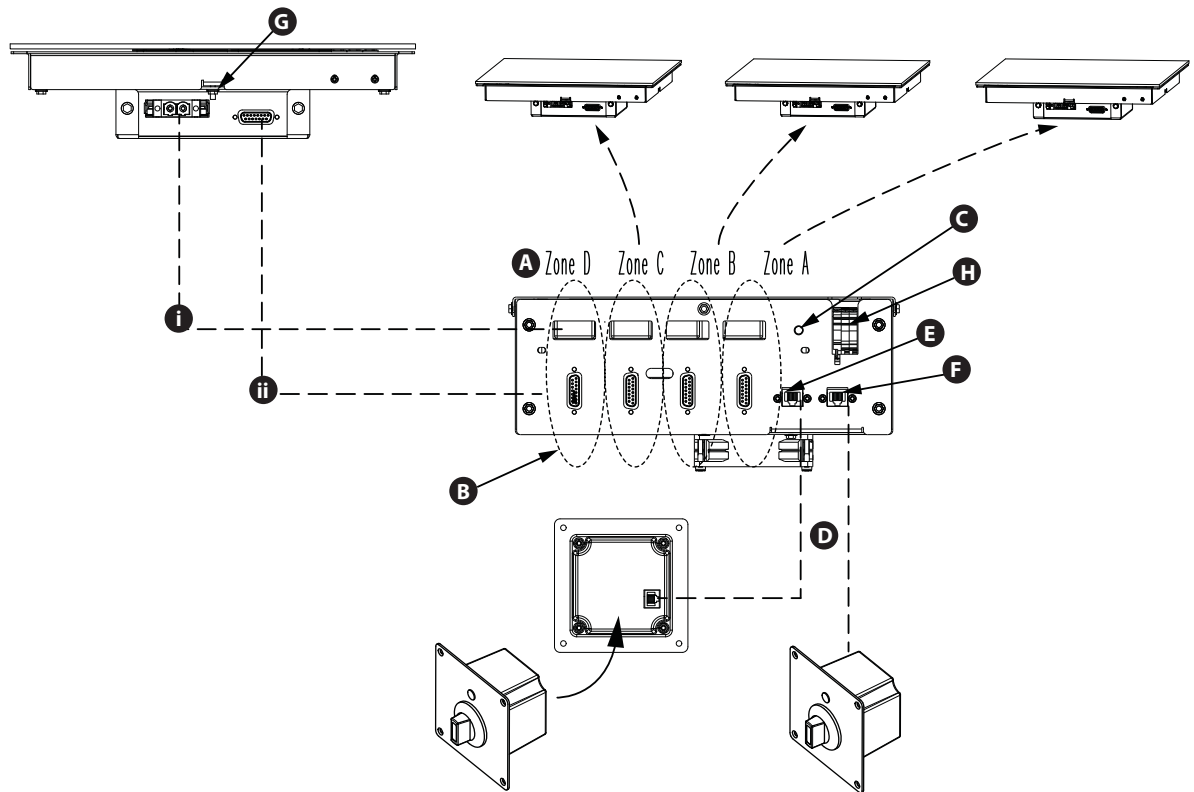

- A.** Each Induction Generator can connect up to four Heat Retaining Plates. Therefore, there are four control zones on a Generator: Zone A, Zone B, Zone C, and Zone D.

**IMPORTANT:** Connect **ONE** Heat Retaining **PLATE** to **ONE ZONE** only.

- Installing 1 Heat Retaining Plate, use any one of the zones.
- Installing 2 Heat Retaining Plates and only one control unit: use Zones A, B OR Zones C, D.
- Installing 2 Heat Retaining Plates and two control units: use Zones A, C OR Zones B, D.
- Installing 3 Heat Retaining Plates, with two control units, use any three of the four zones.

- B.** Within each zone, there are two types of connectors: **(i)** coil and **(ii)** sensor.

Use the coil cable to connect the coil connector on the Plate to the corresponding one on the Generator. Similarly, connect the sensor connectors with the sensor cable provided.

- C.** Secure the grounding cables of the Heat Retaining Plates.

- D.** Up to two Control Units can connect to one Generator. Use the RJ-45 cable(s) provided to connect the Control Unit(s) to the Generator.

- E.** Control Unit connected to the LEFT connector controls both Zones C and D.

- F.** Control Unit connected to the RIGHT connector controls both Zones A and B.

- G.** Connect each built-in frame to earth with the respective grounding bolts.

- H.** Connect the Generator to the power cable.

4. Connect the unit to the power supply.

5. Perform the Function Test. See chapter **5 Function Test**.

## 5 Function Test

### IMPORTANT

#### CAUTION

When the unit is in use, the cookware will warm up the glass-top. To avoid burn injuries, do not touch the glass-top.

- Remove all objects from the glass-top and verify that the glass-top is not cracked or broken.

#### CAUTION

Do not continue if the glass-top is cracked or broken. Immediately switch off the unit and if possible and safe, disconnect it from the power outlet. Contact a Factory Authorized Service agency.

- Before carrying out the function test, the user must understand how to operate the unit.
- Always use a pan or a chafing dish suitable for induction cooking, having a bottom diameter of at least 5"(12cm).
- See **6.1 Proper Induction Chafing Dish or Pan** and **6.2 Proper Placement of Chafing Dish or Pan on Single Hob**.
- NEVER LEAVE AN EMPTY PAN ON AN INDUCTION HOB.**

### To perform a function test:

- Put some water in the induction pan and place it in the center of the hob.
- Turn the control knob to select a temperature between 122-212°F (50-100°C).

The digital Display underneath the Ceran glass shows the selected temperature with point (eg.

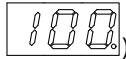

). Within 2 seconds, the display shows the actual temperature and the point blinks

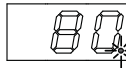

. This means energy is being transferred to the pan and the water is heated.

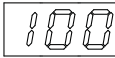
- Take the pan away from the hob and power transmission stops. The display shows the current temperature without point, for example .
- Place the pan back on the hob and the heating process starts again. The point blinks.
- Turn the control knob to the OFF-position and the power transmission stops. If the temperature is over 122°F (50°C), the display shows "hot". Otherwise, the display is off.

When the knob is in an ON-Position and the display remains off, check:

- Is the induction unit connected to the power supply?
- Is the control knob in an ON-Position?

If the point blinks but the pan is not heated up, or the display shows the temperature without a blinking point:

- Are you using a suitable pan or dish? See section **6.1 Proper Induction Chafing Dish or Pan**.
- Is the pan placed in the center of the heating area? See section **6.2 Proper Placement of Chafing Dish or Pan on Single Hob**.

For further assistance, see chapter **10 Troubleshooting** or call a Factory Authorized Service agency.

## 6 Operating Instructions

### IMPORTANT

- Induction units are more powerful, heat up pans quicker, and cook food faster than conventional cooking equipment. Your induction unit will require different use and care than other conventional equipment. Do not operate the induction equipment without reading this manual and follow all safety requirements. Refer to chapter **1 Safety Requirements**.
- This appliance is for professional use and shall be used only by qualified personnel.

### CAUTION

Do not put any empty cookware on the hob when the induction unit is ON. The induction unit heats up empty pans very quickly. Overheated empty pan can cause personal injury and damages to cookware and the induction unit. See **Warranty, p.2**.

To avoid overheating, always put food products or oil into the pan before turning the induction unit on.

- Induction unit offers short cooking time. When you turn the power level up, the temperature of the pan and its contents is changed quickly. Therefore especially when you heat up oil or grease, check the cooking process frequently to prevent the oil or grease from overheating and burning.
- **BROIL-DRY PROTECTION**  
The RTCSmp electronic temperature control monitors overheating at the pan base. When an overheated pan (overheated oil, empty pan) is detected, energy transfer from the generator to the pan will be stopped immediately. You must turn the unit off, let it cool down before re-starting the unit.

### 6.1 Proper Induction Chafing Dish or Pan

**IMPORTANT** Using unsuitable cookware on the induction unit can cause the unit to fail prematurely, void your warranty, or incur high service costs. Refer to **Warranty, p.2**.

- **IMPORTANT: CONDITION OF CHAFING DISH OR PAN**

Pans with layer separation (outward and inward bubbles), arching or partially detached bottoms **must be replaced**. When these pans are used, the sensors under the glass-top cannot detect temperature correctly. **These pans will overheat the sensors below and eventually will damage them.** Illustration below shows examples of good and bad pans in cross-sections.

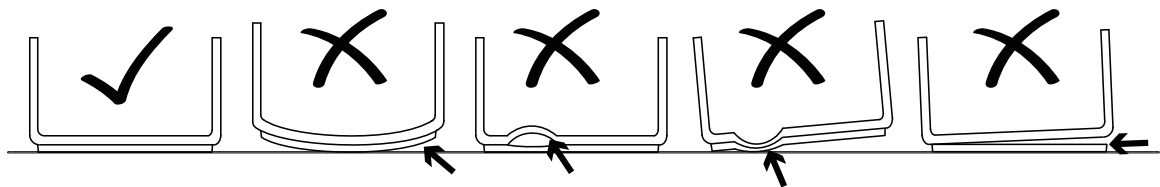

- **Material**

Use cookware made of conductive and magnetic materials. If the pan bottom attracts a magnet, the pan is suitable for induction cooking. Look for cookware that is labeled "suitable for induction" or is marked with an induction compatible symbol.



- **Size**

**Minimum size:** The bottom of the chafing dish or pan must have a diameter of at least 5" (12cm). Otherwise, the sensors will not sense the pan properly.

**Do not use oversized pans** on the induction unit. The bottom of the pan must fit the glass. When a hot, oversized pan covers the silicone joint underneath, the heat from the pan may dry out the silicone overtime and cause this water tight seal to break. The induction unit may fail eventually due to penetration of liquid through the broken silicone seal.

## 6.2 Proper Placement of Chafing Dish or Pan on Single Hob

Each Heat Retaining Plate of the RTCSmp HOIN450/900/1350/1800 models is considered to be one heat-zone. Each heat-zone is equipped with the latest RTCSmp sensor technology which enables temperature controls in realtime. To obtain optimal results from the sensors, you must place the pan in the center of the hob. The pan should always remain in the center for optimal performance.

**CAUTION** Pans and pots must not cover more than one cook zone at a time. Otherwise, electronic components of the induction unit can be damaged.

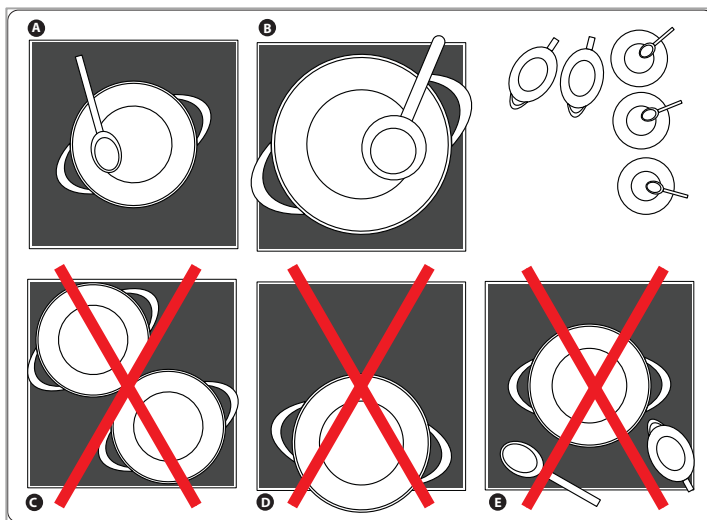

**DO**

**(A) and (B):** Place one pan on each hob, and each pan is placed in the center of the hob. Pan fits the glass.

**DO NOT**

**(C)** Place multiple pans in the same heat-zone.  
**(D)** Place part of the pan outside the hob. The pan should always remain in the center.  
**(E)** Place metallic objects on the hob when the induction unit is in operation.

## 6.3 Temperature Control and Display

### 6.3.1 Configurations and Temperature Control

One RTCSmp HOIN induction generator can control up to four heat retaining plates. Hence, four configurations are available, ranging from one to four heat retaining plates. For each configuration, one temperature control switch controls up to two heat retaining plates. When two heat retaining plates are connected to one switch, both plates would be set to the same set temperature.

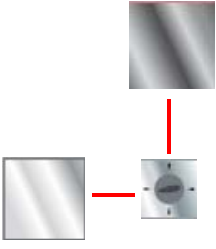
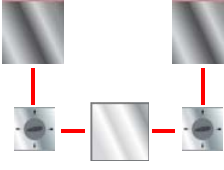
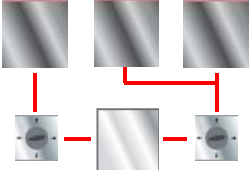
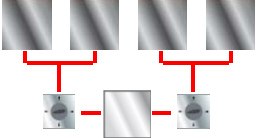
Model	Configuration (Heat Retaining Plate(s), Control Switch(s), and Induction Generator are shown)	
HO IN 450		One switch controls one heat retaining plate.
HO IN 900		Two switches; each controls only one heat retaining plate.
HO IN 1350		Two switches; one switch controls one heat retaining plate and the other switch controls two plates.
HO IN 1800		Two switches; each controls two heat retaining plates.

### 6.3.2 Set and Current Temperatures

Set the desired temperature by turning the control knob and the unit is **immediately ready** for operation. You can adjust the temperature in an increment of 5°F (1°C), from 122-212°F (50-100°C). The digital display underneath the Ceran glass shows the set temperature initially and then followed by the current/actual temperature.

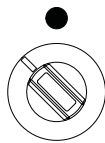

#### ON-Position

Any position where "0"/Line is not pointing straight up.

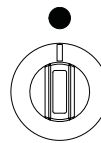

#### OFF-Position

"0" / Line is pointing straight up.

### 6.3.3 Digital Display

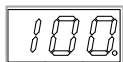

#### Temperature followed by a dot:

When you turn the control knob, the digital display shows the selected temperature with a dot. Within two (2) seconds, the display shows the actual temperature.

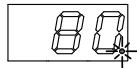

#### Temperature followed by a blinking dot:

The blinking dot indicates the induction zone is active and the current temperature is displayed. This means the system has detected a pan in the heating zone and energy is being transferred to the pan.

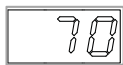

#### Temperature shown without a dot:

The display shows the actual temperature and the induction coil is dormant; no energy is being transferred from the system to the induction pan at the moment or the system cannot detect an induction pan.

**NOTE** Unit with more than one heat retaining plate (RTCSmp HOIN900/1350/1800):

To maximize efficiency with minimal resources, power cycles through the heat retaining plates at set intervals. This means when one plate is active and the temperature is shown with a blinking dot, the other plates lay dormant with temperatures shown without dots. This is normal. However, ensure you are using proper induction pans on the plates.

**To shutdown the unit**, simply turn the control knob to the OFF-position. If the ambient temperature is over 122°F (50°C), the display shows "hot". Otherwise, the display is off.

## 6.4 No Pan No Heat

When a temperature is chosen, the induction unit only transmits energy when a pan is placed in the heating zone. If you remove the pan from the heating zone, power transfer stops immediately. If the pan is put back in the heating zone, power is transferred to the pan again.

Note that pan with a bottom diameter smaller than 5"(12 cm) is not detected by the system.

After switching the unit off, there is no heat retained inside the unit.

## 6.5 When Unit is Not In Use

**Best Practice:** If the induction unit is not in use, ensure the control knob is in the 0 (OFF) position.

- Switch the unit OFF if you take the cookware away for a while. This will prevent the heating process to start automatically and unintentionally when a pan is placed back on the heating area. If any person needs to use the induction unit, he/she will have to turn the unit ON intentionally.

## 7 Cleaning

The cleaning of the Ceran glass is identical to cleaning other similar glass surfaces. You may use any regular glass cleaning products available from a hardware store.

### CAUTION

Ensure no liquid can get into the induction unit. Do not use hoses to clean or power wash the induction unit or its vicinity.



### IMPORTANT

- **DO NOT USE:** corrosive or abrasive cleaning agents, such as grill sprays, oven sprays, stain removers, rust removers, scouring powder, and rough sponges.
- Let the Ceran glass-top cool down before cleaning.
- Ensure to remove all residues of cleaning agents from the glass-top. Use a clean moist cloth to wipe off any such residues.

### IMPORTANT Air Intake Filter

We recommend using an air intake filter in your installation (see section **4.2 Ventilation**). **A dirty, blocked air intake filter can cause electronic damage to the induction unit.** Ensure you check and clean the filter at least once a week or as often as required.

### Glass Cleaning

1. Use razor blade scrapers or non-scratching sponges to remove all residues on the glass.
  - When scraping, ensure you angle your razor blade scraper at about 20° to 30° from the glass.
2. Wipe the glass clean with a damp cloth.

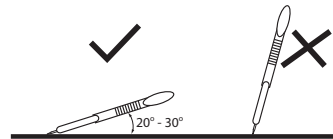

### Visual Inspection of Silicone Seal

Check the silicone seal around the glass. Call for service as soon as possible if you notice:

- Cracks on the silicone seal.
- The silicone seal comes away from the glass or moves when you press down on the seal.

When the silicone seal is broken, water penetration can cause the induction unit to fail, which may also lead to personal harm.

## 8 Maintenance

**CAUTION**

Maintenance and servicing work other than cleaning as described in this manual must be done by an authorized service personnel.

**Do not open the induction unit – dangerous electric voltage inside!**

The induction unit may only be opened by an authorized service personnel.

A good maintenance of the induction unit requires regular cleaning, care and servicing. The operator has to ensure all components relevant for safety are in perfect working order at all times.

**Best Practice:** The induction unit is to be examined once a year by an authorized technician.

## 9 Important Rules

**Six Simple rules to ensure reliable and repeatable performance of your induction unit:**

- Keep kitchen temperature below 105°F (40°C).
- Never place your induction units next to any grease generating or heat generating equipment.
- Clean the intake filter at least once a week or as often as required.
- Use only pans that fits the glass, do not use oversized pans.
- Never pre-heat the pan. Place the pan on the cooking area only when you are ready to cook.
- Do not use dented pans; it will cause damages to the electronics.

# 10 Troubleshooting



Do not open the induction unit – dangerous electric voltage inside!  
The induction unit may only be opened by an authorized service personnel.

## CAUTION

**STOP** and **DO NOT USE** the induction unit if any part of the unit is cracked or broken. Turn off the induction unit immediately and if possible and safe, disconnect the unit from the power supply. Do not touch any parts inside the unit.

## 10.1 Common causes for induction unit failure

One or more of the following conditions may affect the function or contribute to the failure of the induction unit:

- Using unsuitable cookware such as non-induction pans or oversized pans.
- High ambient temperature.
- Inadequate ventilation causing hot air to re-enter the induction unit through the air intake slots.
- Dirty air intake filter.
- Empty pans are left on the cook-top when the unit is ON.

### Symptoms

When a malfunction occurs, the induction unit may be in one of the following states:

- The induction unit stops working immediately.
- The induction unit continues to work in a power reduction mode.
- The induction unit continues to work as usual.

When the display shows an error code (e.g. E04), record the error code and contact your authorized service agency.

### Corrective steps

Use the following sections to locate the problem area(s) and to take only the corrective action(s) indicated. Ensure you exercise safety precautions at all time.

Only an authorized service technician would have the training and correct tools to diagnose the internal components accurately and thoroughly. Contact a Factory Authorized Service agency for assistance. For a list of Garland authorized service agencies, please visit our website [www.garland-group.com](http://www.garland-group.com).

## 10.2 Problems and Possible Causes

Problem	Possible Causes	Action To Take By Operator
<b>Pan does not heat, digital display is OFF (dark)</b>	No power supply.	Check the electrical supply, e.g. power cable plugged into the wall socket. Check primary fuses.
	Control knob is in OFF-position.	Turn control knob to an ON-position.
	Defective induction unit.	Ensure knob is in OFF-position and if possible and safe, disconnect the unit from the power supply. Contact your authorized service agency.
<b>Pan does not heat. If an error code is shown, see next section.</b>	Pan is too small.	Use a suitable pan with bottom diameter larger than 5" (12cm).
	Pan is not placed in the heating zone; pan is not detected by sensor.	Place the pan in the center of the heating zone.
	Unsuitable pan.	Select a pan recommended for the induction unit.
<b>Poor heating, digital display is ON (shining).</b>	Defective induction unit.	Ensure knob is in OFF-position and if possible and safe, disconnect the unit from the power supply. Contact your authorized service agency.
	Pan is not suitable.	Select a pan recommended for the induction unit. Then compare the results.
	Air-cooling system obstructed.	Verify that air inlet and outlet are not obstructed. Ensure the Intake Air Filter is clean.
	Ambient temperature is too high; the cooling system is not able to keep the induction unit in normal operating conditions.	Verify that no hot air is sucked in by the fan. Reduce the ambient temperature. The intake air temperature must be lower than 104°F (40°C).
<b>Unit does not react to control knob positions</b>	Defective induction unit.	Ensure knob is in OFF-position and if possible and safe, disconnect the unit from the power supply. Contact your authorized service agency.
	Defective control switch.	Ensure knob is in OFF-position and if possible and safe, disconnect the unit from the power supply. Contact your authorized service agency.
<b>Power/heating level seems to be reduced, <u>fan is working</u></b>	Air-cooling system is blocked. Internal fan is dirty.	Verify that air inlet and outlet are not obstructed. Ensure the Intake Air Filter is clean. Contact your authorized service agency.
<b>Power/heating level seems to be reduced, <u>fan does not work</u></b>	Defective fan or fan control.	Ensure knob is in OFF-position and if possible and safe, disconnect the unit from the power supply. Contact your authorized service agency.
<b>After a longer permanent operating time, Power/heating level seems to be reduced</b>	Overheated induction coil; cooking area is too hot. Overheated oil in pan. Pan is empty.	Switch the unit off. Safely remove pan. Wait until the heating zone has cooled down before turning the unit ON again.

**NOTE:** The fan starts when the ambient temperature in the control area exceeds 140°F/60°C. At heat temperatures higher than 167°F/75°C, the controller automatically reduces the power to keep the unit in normal operating conditions. The full power of the device is at heat sink temperature of 158°F/70°C, running freely again.

### 10.3 Troubleshooting with Error Codes (for Service Technicians)

To obtain the internal data for troubleshooting, you need an IR Adapter, proper connectors, and software. The table below is a reference guide. For further information and assistance, please contact Garland Technical Service.

Error Code	Reason	Things To Check
E01	Hardware overcurrent or coil is not connected(1)	Check the Chafing Dish or Pan material, Check wiring.
E02	Software overcurrent (1)	Check the Chafing Dish or Pan material.
E03	Heat sink overtemperature T > 85°C (1)	Check installation (Airflow).
E04	Empty cooking detektor Total failure of the sensor unit or sensor unit not connected (1)	Check sensor unit. Set point: 1080Ohm at 25°C
E05	Potentiometer defect or not connected (1)	Check the potentiometer wiring.
E06	Temperature inside the generator too high.T > 80°C (1)	Check installation (Airflow).
E10	Reduction KK temperature T > 75°C (2)	Check installation (Airflow).
E12	Reduction internal temperature T > 70°C (2)	Check installation (Airflow).
E20	Faulty or not connected heat sink temperature sensor (1)	Contact Garland.
E21	Board sensor defect (1)	Contact Garland.
E24	Temperature processor central unit > 100°C (1)	Check installation (Airflow).
E30	Heat retention plate sensor 1 over temperature or defect (1)	Check warming process. Check sensor 1 Set point: 1080Ohm at 25°C
E41	Heat retention plate sensor 2 over temperature or defect (1)	Check warming process. Check sensor 2 Set point: 1080Ohm at 25°C
E42	Heat retention plate sensor 3 over temperature or defect (1)	Check warming process. Check sensor 3 Set point: 1080Ohm at 25°C
E43	Reduction KK temperature T > 75°C (2)	Check installation (Airflow).

(1) Power supply is interrupted immediately.

(2) The unit works with reduced power.

## NOTES

# NOTES

## CORRECT DISPOSAL OF THIS PRODUCT



This marking  shown on the product indicates that the product should not be disposed as household waste or regular commercial waste. Instead it shall be handed over to the applicable collection point for the recycling of electrical and electronic equipment. By ensuring this product is disposed correctly, you will help prevent potential harm to the environment or human health, which could otherwise be caused by inappropriate waste handling of this product.

For more detailed information regarding recycling of the product, please contact your local city office, your waste disposal service or your equipment dealer.

**IMPORTANT** Induction units, sent for disposal, can be brought back into operation and their use should be avoided.

**NOTE** The unit is built with common electrical, electromechanical, and electronic parts. No batteries are used.

**NOTE** The owner and operator are responsible for the proper and safe disposal of the induction unit.

# **Garland** Installation & Operation Manual

---

GARLAND BUILT-IN TEMPERATURE CONTROLLED INDUCTION HOLD-LINE with RTCSmp TECHNOLOGY

Garland Commercial Ranges Ltd.  
1177 Kamato Road, Mississauga,  
Ontario, CANADA L4W 1X4

T. 1-905-624-0260  
F. 1-905-624-5669  
[www.garland-group.com](http://www.garland-group.com)

USA Sales, Parts and Service 1-800-424-2411  
Canadian Sales 1-888-442-7526  
Canada or USA Parts/Service 1-800-427-6668

