



***MCO HALF SIZE MODELS (electric)
MCO-E-5 FROM 2000 AND UP***

PARTS LIST

Toll Free Phone, (US & Canada): (800) 427-6668

Toll Free Fax, (US & Canada): (800) 361-7745

<http://www.garland-group.com>



MCO HALF SIZE MODELS (electric) MCO-E-5 FROM 2000 AND UP

Contents:

MCO-E-5 Master 200 Mechanical Control Panel W/Timer	Page 4
MCO-E-5 Master 300 Control Panel.....	Page 6
MCO-E-5 Master 450 Electronic Control W/Cook - N - Hold.....	Page 8
MCO-E-5 Master 470 Electronic Programmable Control.....	Page 10
MCO-E-5 Master 475 Electronic Programmable Control.....	Page 12
MCO-E-5 Elements & Components.....	Page 14
MCO-E-5 Door Components	Page 16
MCO-E-5 Oven Components	Page 18
MCO-E-5 Main Exterior	Page 20
MCO-E-5 Hood Interlock Components.....	Page 22
Revision History.....	Page 24

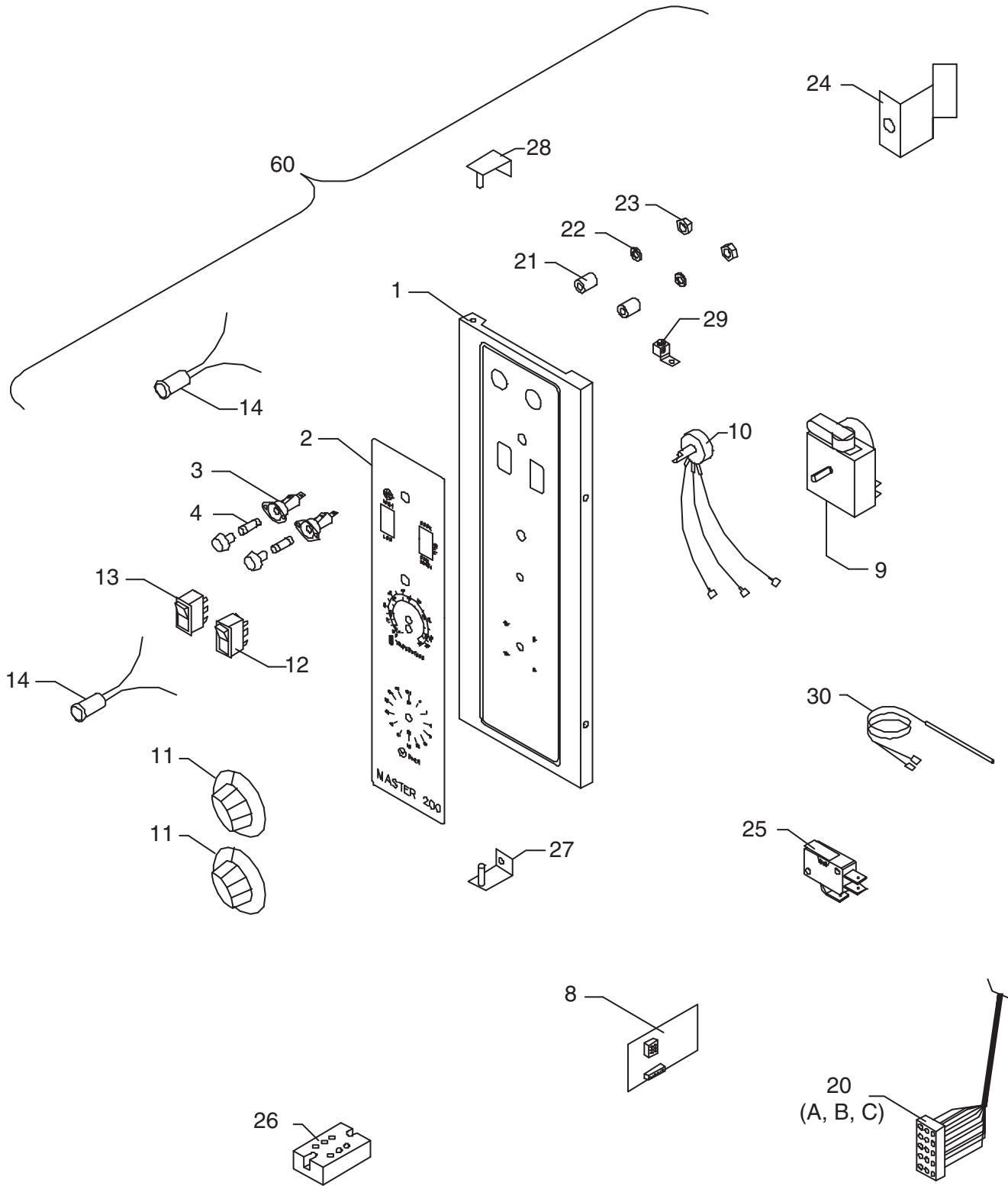

GARLAND PARTS IDENTIFICATION
MCO-E-5 MASTER 200 Mechanical Control Panel W/Timer

ITEM	PART #	DESCRIPTION	QTY	DATE	
				FROM	UP TO
1	1946619	Control Panel MCO-E-5 IM200	1		
2	1908528	Overlay MCO 200 WO/Light	1		
3	1774101	Fuse Holder 600V 30A HPG	2		
4	1130108	Fuse - 10 Amp 600V N.L.A.	2		7-May-03
	4513157	Fuse - 10 Amp 600V Time Delay		7-May-03	
8	1955501	Power Control Board - IM200, 150-500 DEG F	1		
9	1956002	Timer - 1 HR, 208/240V W/Alarm	1	25-Oct-02	
	1956001	Timer - 1 HR, 115V W/Alarm			25-Oct-02
10	1955601	Potentiometer - IM200 150-500DEG	1		
11	1765802	Fluted Knob W(2) Set Screws	2		
12	1955401	Switch Rocker ON-OFF-ON	1		
13	1955402	Switch Rocker ON-ON	1		
14	1270000	Amber Pilot Light 28V	1		9-Sep-00
	1936104	Indicator Lamp-Amber, 250V		9-Sep-00	
	1006493	Pilot Light Green 240V			9-Sep-00
	1936102	Indicator Lamp-Green, 250V		9-Sep-00	
20a	1804745	Harness Main IM200 MCO-E-5	1		
20b	1804741	Harness Main Panel IM200			
20c	1804747	Harness Door SW IM200 MCO-E-5			
21	1955701	Standoff - Nylon - 1/4X1/2X1	2		
22	1955801	Washer - Teflon - 7/16 OD	2		
23	8001502	Nut W/LWasher 6-32 KEP	2		
24	1768701	Probe Holder	1		
25	9006402	Switch Mini Snap Hi-Temp 15amp	1		
		Location: Door Switch on the Top Left Hand Corner			
26	1767801	Enclosed Terminal Block 3 Pole	1	30-Jan-02	
27	1382597	Control Panel Bracket Bottom	1		
28	1382502	Control Panel Bracket Top	1		
29	1028402	Ground Lug	1		
30	1773501	Enclosed Probe W/36" Leads	1		22-Jan-03
	9006800	Probe Tube		22-Jan-03	
31*	1382659	Installation / Operation Manual			
32*	1103307	Terminal Block Marking Strip	1	30-Jan-02	
33*	1807857	Wiring Diagram IM200 60HZ 208/240V 2SP			

Kits Available

50*	1957884	B/A MCO-E-5 IM200 Panel / Overlay Included Items: 1, 2, 3, & 4	1		
60	1957984	IM200 MCO-E-5 Control Panel - Included Items: 8, 9, 10, 11, 12, 13, 14, 20B, 21, 22, 23 & 50	1		

* NOT ILLUSTRATED

RECOMMENDED STOCK PARTS

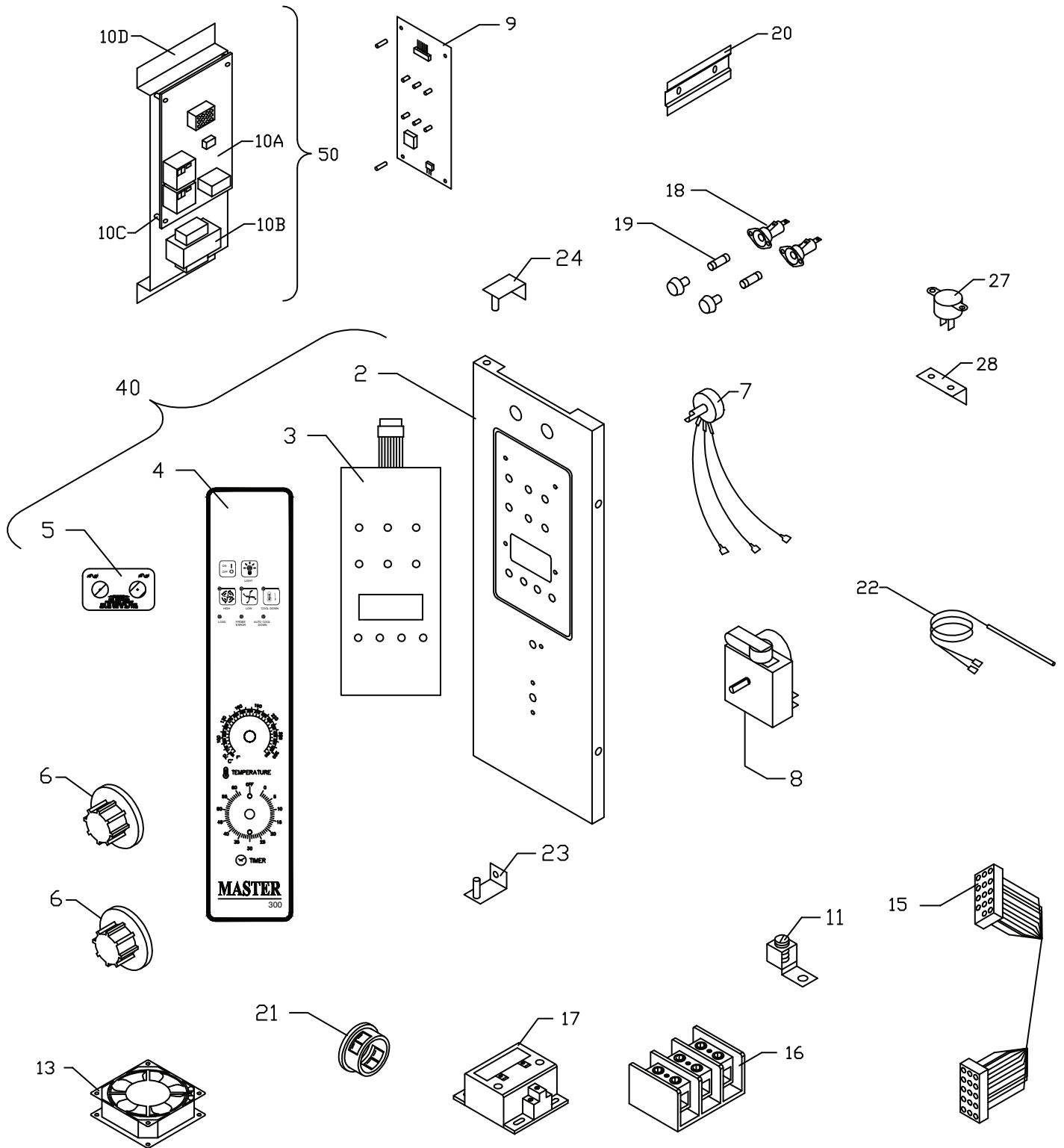

Master 300 Control (electric)

GARLAND PARTS IDENTIFICATION

MCO-E-5 Master 300 Control Panel

ITEM	PART #	DESCRIPTION	QTY	DATE	
				FROM	UP TO
2	1946694	Control Panel IM300	1		
3	1911701	Key Pad Fast Control	1		
4	1908514	Overlay MCO 300 WO/Light	1		
5	1908518	Overlay 10 Amps Fuse	1		
6	1765802	Fluted Knob W(2) Set Screws	2		
7	1911801	Potentiometer	1		
8	1285701	Mallory 1 Hr Timer 230V 50/60H	1		
9	1905701	Solid State 300 Digital Control	1		
10A	1916901	Relay Board	1		
10B	1917102	Transformer 208-240V	1		
10C	1767901	Teflon Spacers	4		
10D	1916801	Relay Board Assy Bracket	1		
11	1028400	Ground Lug	1		
13	1918202	Fan - 110MM, 208/240V		Oct/18/99	
15	1804728	Main Harness	1		
16	1193900	Terminal Block 3 Pole	1		
17	9005400	Mercury Contactor 208V/240V	1	Sept/9/99	
18	1130102	Fuse Holder	2		
19	1130103	Fuse SC-20 300V 20 Amp	2		
20	1911301	Relay Bracket Slide	2		
21	1028804	Snap Bushing .375 Dia	1		
	1028807	Snap Bushing .750 Dia	1		
22	1906001	Sensor Probe	1		
23	1382597	Control Panel Bracket Bottom	1		
24	1382502	Control Panel Bracket Top	1		
25*	1807829	Wiring Diagram Fast Control 208/240V 60HZ			
	1807843	Wiring Diagram 220/380/50HZ Manual - Export			
	1807831	W/D Fast Control 220/380-240/415 50 HZ-2 SP			
	1807830	W/D Fast Control 460V 60 HZ-2 SP			
26*	1382659	Installation / Operation Manual			
27	1955101	Switch Thermal Disc (Cooling Fan)	1		
28	1910901	Thermal Disc Bracket	1		

Kits Available

40	CK1957899	Kit MCO-E-5 - IM300 Overlay Include Items 2, 3, 4,5	1		
50	1908202	Relay Board Assembly - 208/240 V	1		28-Sep-99
	1917098	Relay Board Assembly - 208/240V	1	28-Sep-99	
	1917099	Relay Board Assembly - 120V			

* NOT ILLUSTRATED

RECOMMENDED STOCK PARTS

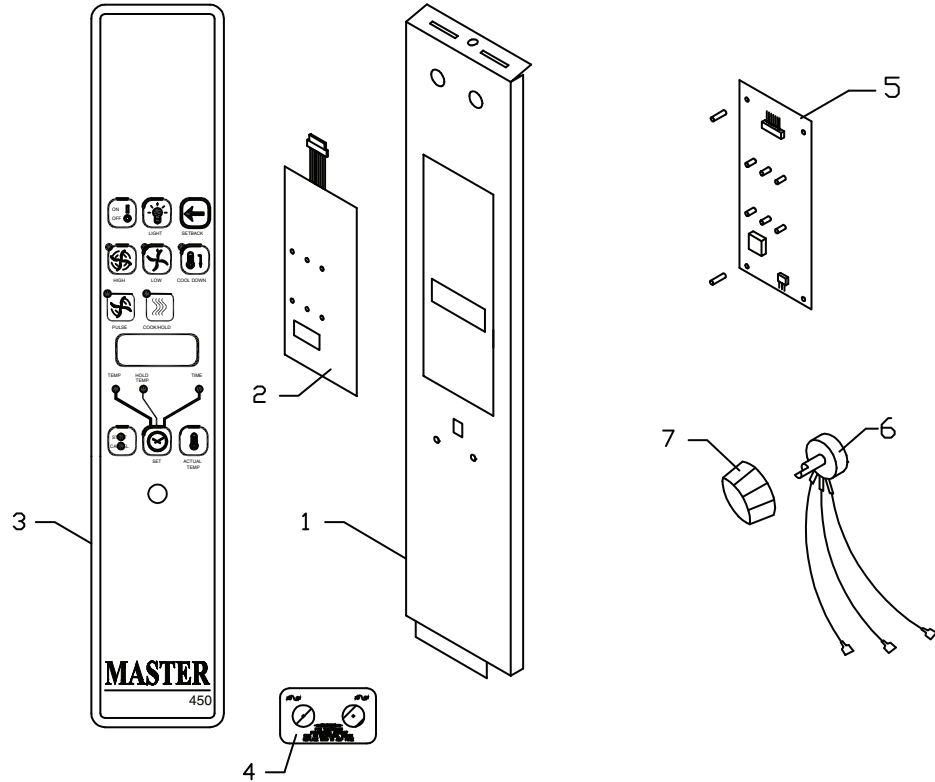
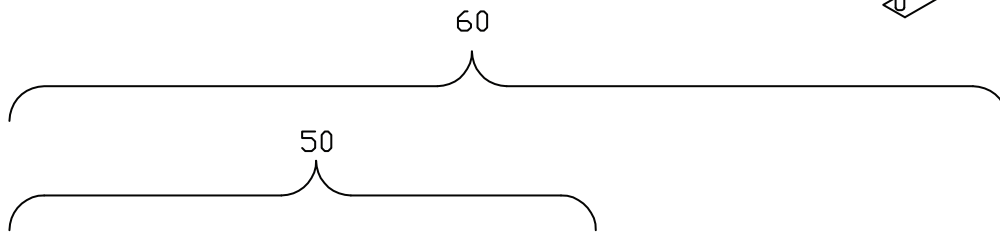
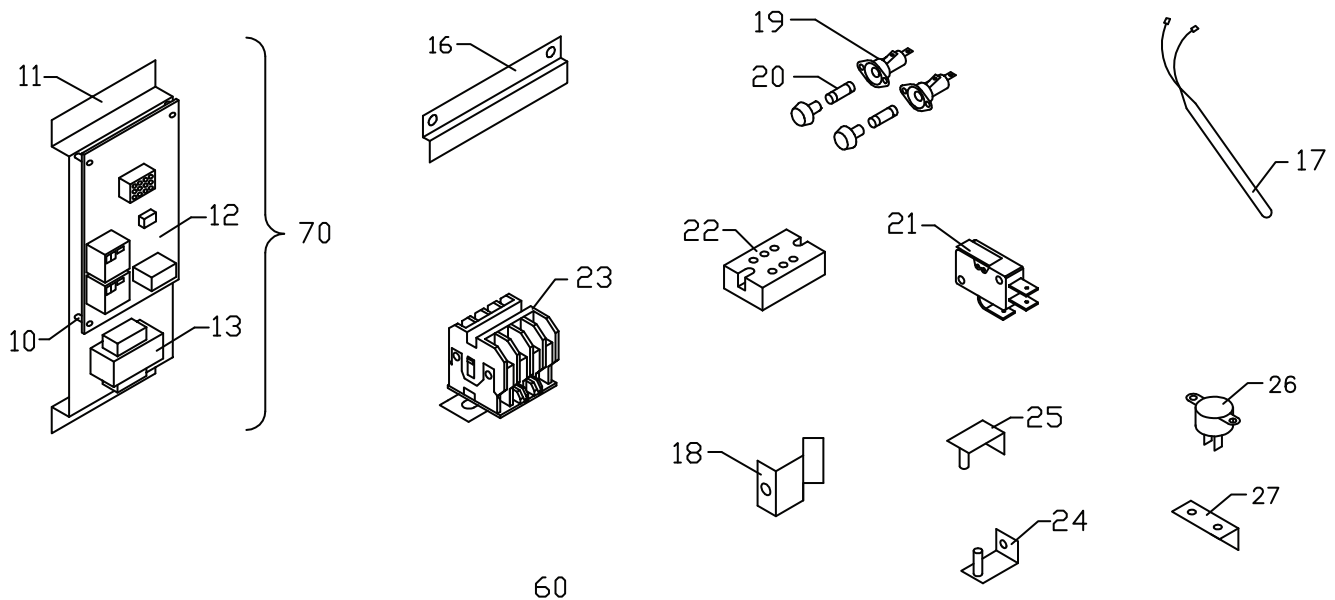

GARLAND PARTS IDENTIFICATION

MCO-E-5 Master 450 Electronic Control W/COOK - N - HOLD

ITEM	PART #	DESCRIPTION	QTY	DATE	
				FROM	UP TO
1	1946695	Control Panel	1		
2	1911701	Keypad Fast Control	1		
3	1908504	Overlay - 450 Control Without Light	1		
	1908503	Overlay - 450 Control With Light			
4	1908518	Overlay 10 Amps Fuse	1		
5	1905703	C&H 450 Control Deg. F.	1		
6	1911601	Encoder (For Spares)	1		
7	1720502	Fast Control Knob	1		
10	1767901	Nylon PCB Spacer	4		
11	1916801	Bracket - Relay Board	1		
12a	1916901	Relay Board PCB Assembly	1	14-Oct-99	
12b	1916903	Relay Board PCB Assembly - CE Models			
13a	1917198	Transformer 208/240V	1	9-Sep-99	
	1917102				9-Sep-99
13b	1917103	Transformer - 230V CE Models	1		
14*	1949565	Jumper - CE Relay Board	2	9-Sep-99	
15*	1949566	Jumper Asm - Transformer Leads	2	2-Jul-01	
16	1787302	Component Bracket Slide	2		
17	1773501	Enclosed Probe W/36" Leads	1		22-Jan-03
	9006800	Probe Tube	1	22-Jan-03	
18	1768701	Probe Holder	1		
19	1774101	Fuse Holder 600V 30A HPG	2		
20	1130108	Fuse - 10 Amp 600V N.L.A.	2		7-May-03
	4513157	Fuse - 10 Amp 600V Time Delay			7-May-03
21	9006401	Switch Mini Snap Hi-Temp 1 Amp Location: Door Switch on the Top Left Hand Corner	1	17-Jan-02	
22	1767801	Enclosed Terminal Block 3-Pole	1	30-Jan-02	
23	1860108	Terminal Block 5 Lug	1	30-Jan-02	
24	1382597	Control Panel Bracket Bottom	1		
25	1382502	Control Panel Bracket Top	1		
26	1955101	Switch Thermal Disc (Cooling Fan)	1		
27	1910901	Thermal Disc Bracket	1		
30*	1804730	Main Harness MCO-E-5	1		
31*	1804731	Door Harness MCO-E-5			
32*	1807845	Wiring Diagram 208/240 60HZ Electronic	1		
	1807846	Wiring Diagram 220/380 50HZ Electronic	1		
33*	1382659	Installation / Operation MCO-E5/25 US/CAN	1		
	1947424	Installation / Operation MCO-E5/25 CE Models			

Kits Available

50	CK1957897	Assembly Panel MCO-E-5 Included Items 1, 2, 3, 4	1		
60	1957997	Assembly Panel MCO-E-5 Included Items: 50, 5, 6, 7	1		
70	1917098	Relay Assembly 208/240V Included Items 10, 11, 12a, & 13a	1	28-Sep-99	
	1917097	Relay Board Assembly - CE Models Included Items 10, 11, 12b, 13b, 47*, 48*	1		

* NOT ILLUSTRATED

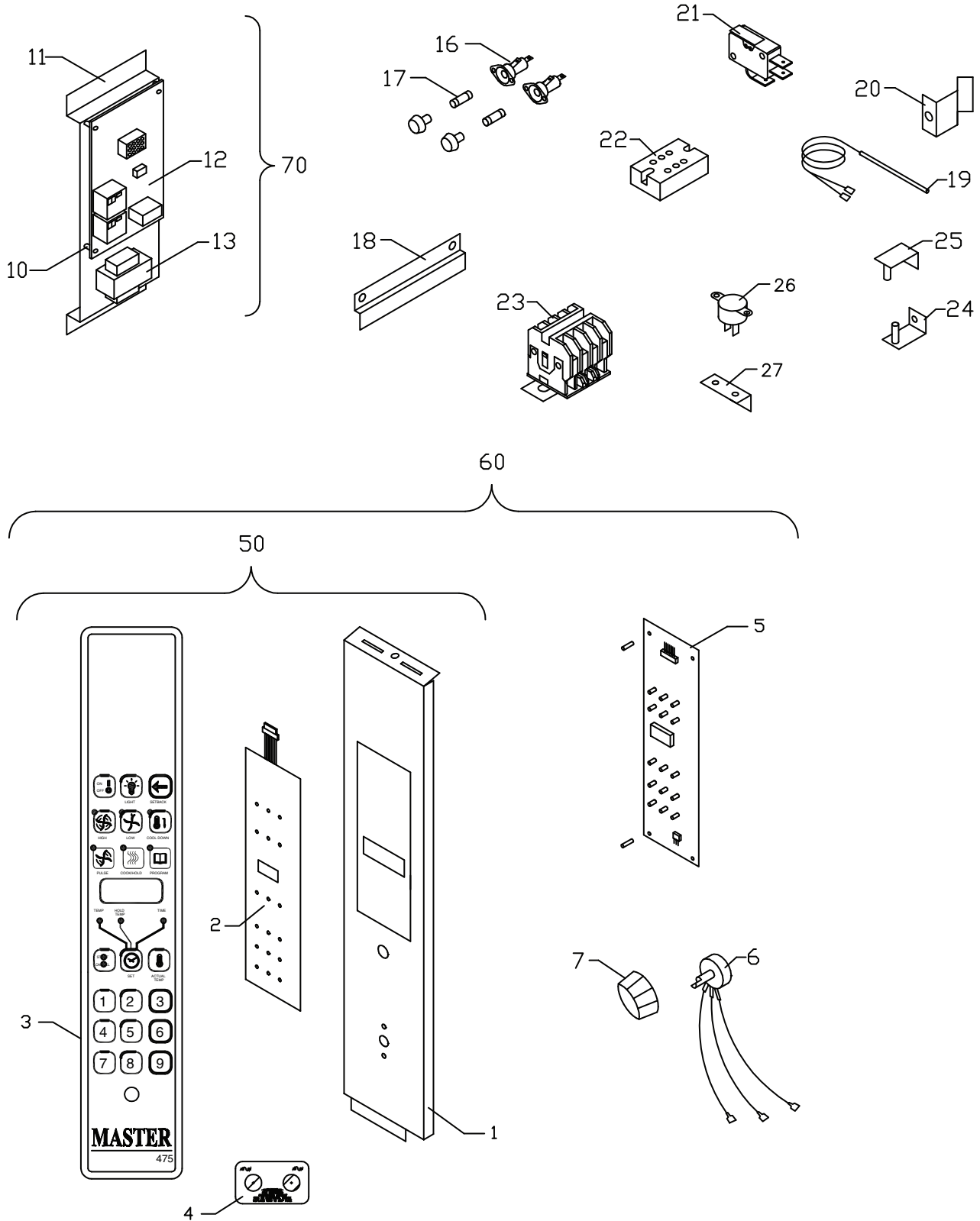

Master 470 Control (electric)

GARLAND PARTS IDENTIFICATION
MCO-E-5 MASTER 470 Electronic Programmable Control

ITEM	PART #	DESCRIPTION	QTY	DATE	
				FROM	UP TO
1	1946686	Control Panel MCO-E-5 IM475 ASSY	1		
2	1911702	Membrane - Chain Control Keypad	1		
3	1908525	Overlay 470 Chain W/O Light	1		
4	1908518	Overlay 10 AMP Fuse	1		
5	1905709	PCM Assembly - 470 Chain Controller	1		
6	1911601	Encoder (For Spares)	1		
7	1720502	Fast Control Knob	1		
10	1767901	Nylon PCB Spacer	4		
11	1916801	Bracket - Relay Board	1		
12a	1916901	Relay Board PCB Assembly	1		
12b	1916903	PCB Assembly CE			
13a	1917102	Transformer 208/240V	1		
13b	1917103	Transformer - 230V CE			
14*	1949565	Jumper -Relay Board - CE Units	1	9-Sep-99	
15*	1949566	Jumper Assembly - Transformer - CE Units	1	2-Jul-01	
16	1774101	Fuse Holder 600V 30A HPG	2		
17	1130108	Fuse - 10 Amp 600V N.L.A.	2		7-May-03
	4513157	Fuse - 10 Amp 600V Time Delay			7-May-03
18	1787302	Component Bracket Slide	1		
19	1773501	Enclosed Probe W/36" Leads	1		22-Jan-03
	9006800	Probe Tube			22-Jan-03
20	1768701	Probe Holder	1		
21	9006401	Switch Mini Snap Hi-Temp 1 Amp	1	17-Jan-02	
22	1767801	Enclosed Terminal Block 3 Pole	1	30-Jan-02	
23	1860108	Terminal Block 5 Lug	1	30-Jan-02	
24	1382597	Control Panel Bracket Bottom	1		
25	1382502	Control Panel Bracket Top	1		
26	1955101	Switch Thermal Disc (Cooling Fan)	1		
27	1910901	Thermal Disc Bracket	1		
30*	1804730	Main Harness MCO-E-5	1		
31*	1804731	Door Harness MCO-E-5	1		
32*	1807845	Wiring Diagram 208/240 60HZ Electronic	1		
	1807846	Wiring Diagram 220/380 50HZ Electronic			
	1807861	Wiring Diagram, TJ Cinnamons IM470			
33*	1382659	Installation & Operation Manual MCO-E5/25 US/CAN	1		
	1947424	Installation & Operation Manual MCO-E5/25 CE			

Kits Available

50	CK1957895	Kit-MCO-E-5 IM470 Mem./Overlay Included Items 1, 2, 3, 4	1		
60	CK197995	Kit-MCO-E-5-IM470 Control Includes Items 4, 5, 6, & 50	1		
70	197098	Relay Board Assembly -208/240V Includes Items: 10, 11, 12a, 13a	1		
	1917097	Relay Board Assembly -CE Models Includes Items 10, 11, 12b, 13b, 14, 15	1		

* NOT ILLUSTRATED

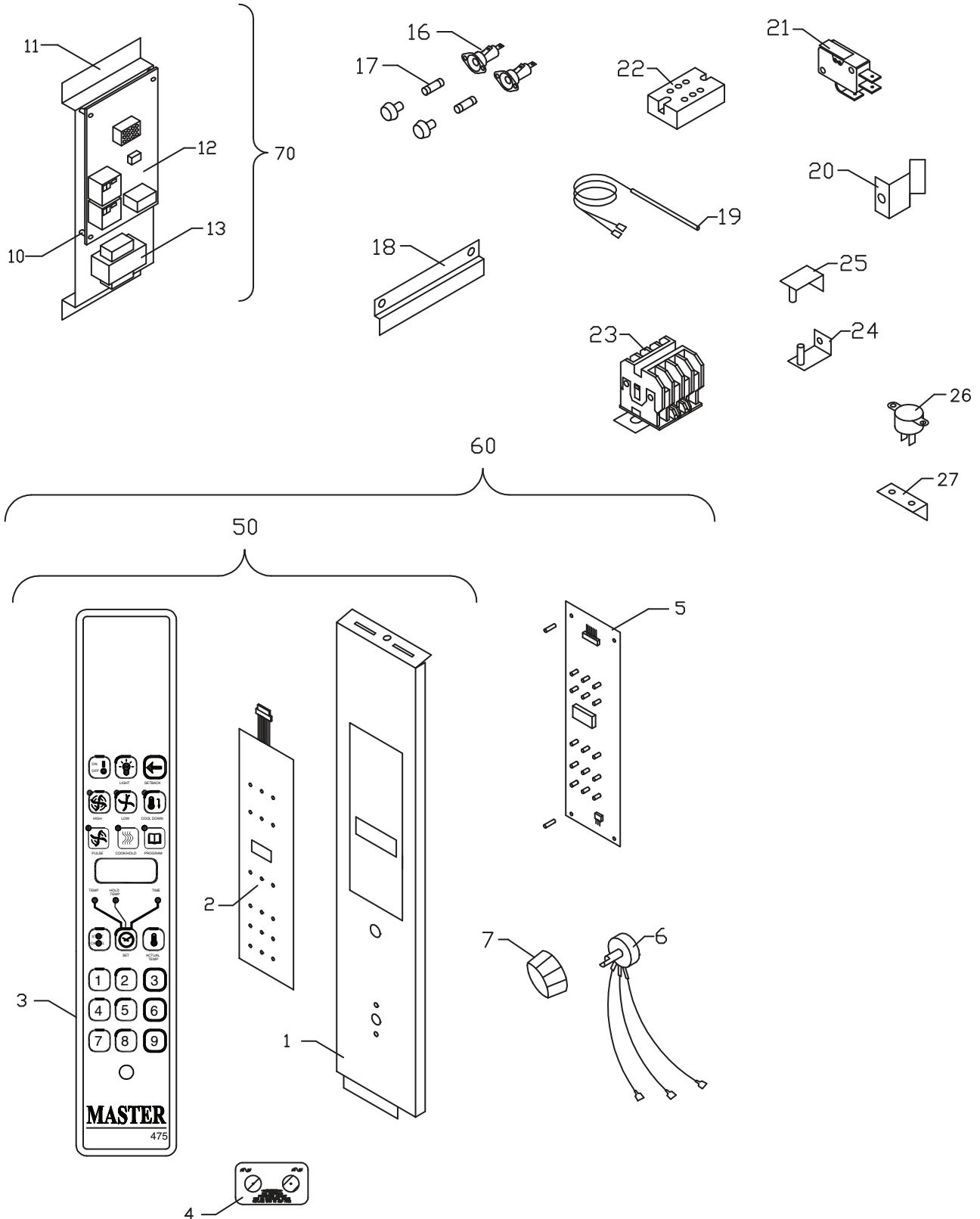

GARLAND PARTS IDENTIFICATION
MCO-E-5 Master 475 Electronic Programmable Control

ITEM	PART #	DESCRIPTION	QTY	DATE	
				FROM	UP TO
1	1946686	Control Panel MCO-E-5 IM475 ASSY	1		
2	1911702	Membrane - Chain Control Keypad	1		
3	1908520	Overlay - 475 Chain W/O Light	1		
4	1908518	Overlay 10 AMP Fuse	1		
5	1905708	PCB Assembly - Chain Controller			
6	1911601	Encoder (For Spares)	1		
7	1720502	Fast Control Knob	1		
10	1767901	Nylon PCB Spacer	4		
11	1916801	Bracket - Relay Board	1		
12a	1916901	Relay Board PCB Assembly	1		
12b	1916903	Relay Board Assembly - CE			
13a	1917198	Transformer 208/240V	1		
13b	1917103	Transformer 230V CE Models			
14*	1949565	Jumper - CE Relay Board		9-Sep-99	
15*	1949566	Jumper Assembly - Transformer CE		2-Jul-01	
16	1774101	Fuse Holder 600V 30A HPG	2		
17	1130108	Fuse - 10 Amp 600V N.L.A.	2		7-May-03
	4513157	Fuse - 10 Amp 600V Time Delay			7-May-03
18	1787302	Component Bracket Slide	2		
19	1773501	Enclosed Probe W/36" Leads	1		22-Jan-03
	9006800	Probe Tube			22-Jan-03
20	1768701	Probe Holder	1		
21	9006401	Switch - Mini Snap Hi Temp 1 Amp	1	17-Jan-02	
22	1767801	Enclosed Terminal Block 3 Pole	1		
23	1860108	Terminal Block 5 Lug	1	30-Jan-02	
24	1382597	Control Panel Bracket Bottom	1		
25	1382502	Control Panel Bracket Top	1		
26	1955101	Switch Thermal Discs (Cooling Fan)	1		
27	1910901	Thermal Disc Bracket	1		
30*	1804731	Door Harness MCO-E-5	1		
	1804730	Main Harness MCO-E-5	1		
31*	1807845	Wiring Diagram 208/240 60HZ Electronic	1		
	1807846	Wiring Diagram 220/380 50HZ Electronic			
32*	1382659	Installation / Operation MCO-E5/25 US/CAN	1		
	1947424	Installation / Operation MCO-E5/25 CE	1		

Kits Available

50	CK1957896	Kit MCO-E-5 IM475 Mem./Overlay Includes Items 1, 2, 3, 4	1		
	CK1957996	Kit-MCO-E-IM475 Control Panel Includes Items: 50, 5, 6, 7	1		
70	1917098	Relay Board Assembly - 208/240V Includes Items: 10, 11, 12a, 13a	1		
	1917097	Relay Board Assembly CE Incudes Items: 10, 11, 12b, 13b, 32*, 33*	1		

* NOT ILLUSTRATED

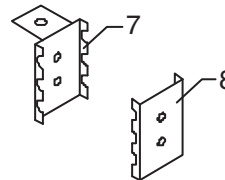
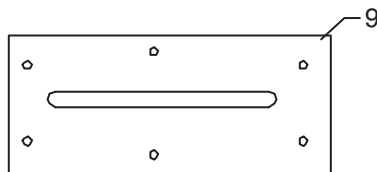
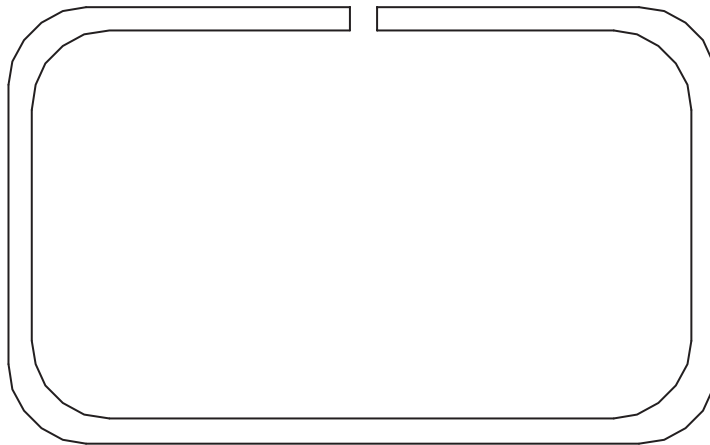
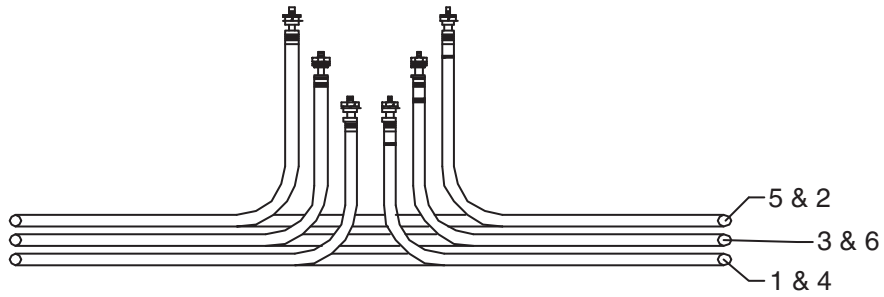

GARLAND PARTS IDENTIFICATION
MCO-E-5 Elements & Components

ITEM	PART#	DESCRIPTION	QTY	DATE	
				FROM	UP TO
1	1765101	Element Inner 208V 2500W	1		
		(IM) 200/450) 208V - 60Hz - (5.0 & 7.5Kw)	1		
		IM475 -208V - 60Hz - (5.0 & 7.5 Kw)	1		
		IM470 -208V- 60Hz - 5.0K	1		
2	1765102	Element Outer 208V 2500W	1		
		(IM) 200/450) 208V - 60Hz - (5.0 & 7.5Kw)	1		
		IM475 -208V - 60Hz - (5.0 & 7.5 Kw)	1		
		IM470 -208V- 60Hz - 5.0K	1		
3	1765111	Element Center 208V 2500W	1		
		IM 200/450 - 208V 60Hz - 7.5Kw Only	1		
		IM475 -208V - 60Hz - 7.5K	1		
		IM470 -208V- 60Hz - 7.5K	1		
4	1765109	Element Inner 240V 2500W	1		
		IM 200/450 - 240V 60Hz - (5.0 or 7.5Kw)	1		
		IM450 220/380V 50Hz (5.0 & 7.5kw) - CE Models	1		
		IM475 - 240V - 60Hz (5.0 & 7.5Kw)	1		
		IM475 220/380V 50Hz (5.0 & 7.5Kw)	1		
		IM470 - 240V -60Hz (5.0 & 7.5Kw)	1		
5	1765110	Element Outer 240V 2500W	1		
		IM 200/450 - 240V 60Hz - (5.0 or 7.5Kw)	1		
		IM450 220/380V 50Hz (5.0 & 7.5Kw) - CE Models	1		
		IM475 - 240V - 60Hz (5.0 & 7.5Kw)	1		
		IM475 220/380V 50Hz (5.0 & 7.5Kw)	1		
		IM470 - 240V -60Hz (5.0 & 7.5Kw)	1		
6	1765112	Element Center 240 Volt 2500W	1		
		IM 200/400 - 240V - 60Hz - 7.5 Kw only	1		
		IM475 - 240V - 60Hz 7.5	1		
		IM475 220/380V 50Hz 7.5Kw	1		
		IM470 - 240 -60Hz -7.5Kw	1		
		IM470 - 220/380V- 50Hz - 7.5Kw	1		
7	1765105	Element Holder With Flange	5		
8	1765106	Element Holder With Out Flange	5		
9	1765108	Element Oven Patch	1		

* NOT ILLUSTRATED

RECOMMENDED STOCK PARTS

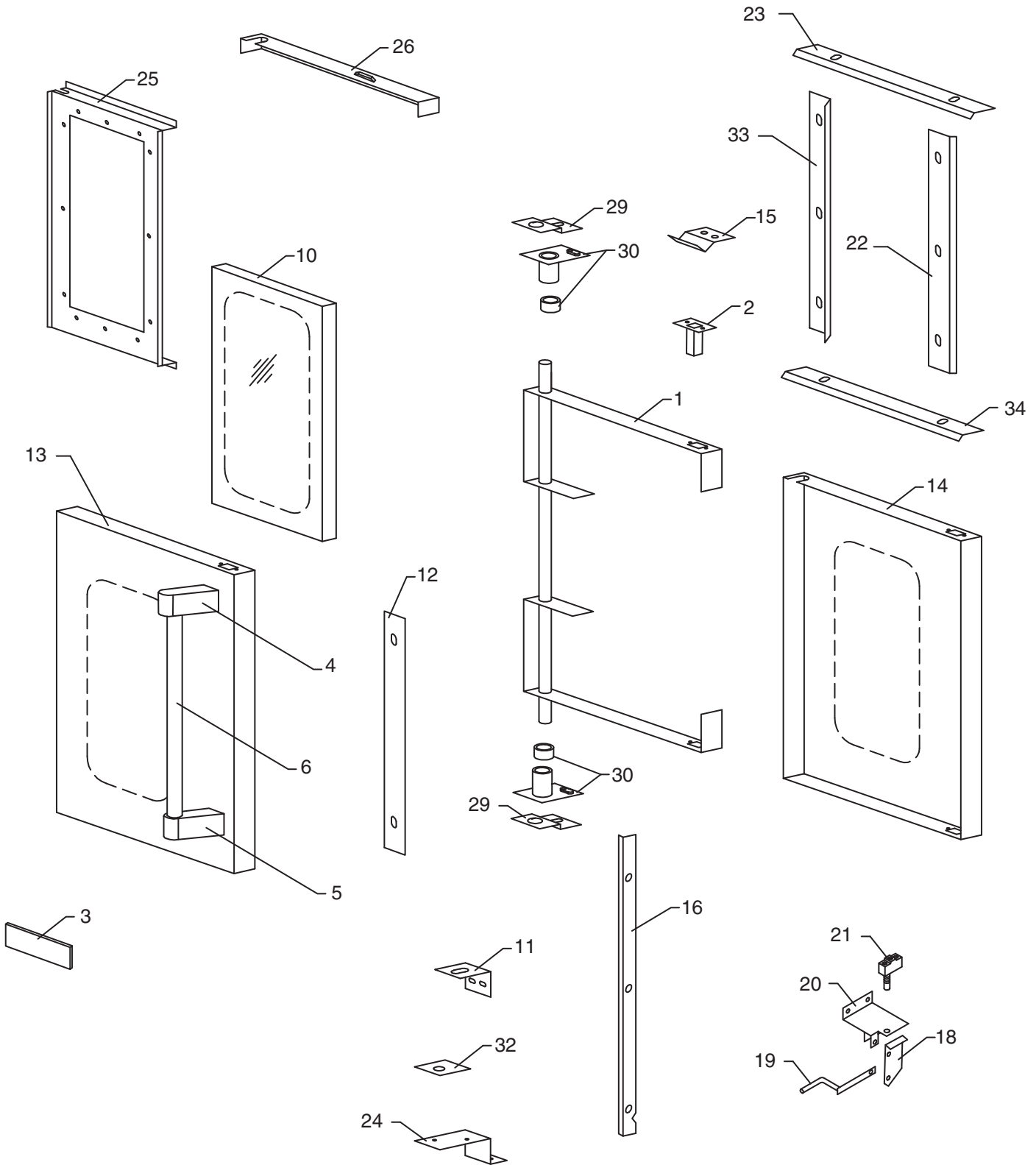

GARLAND PARTS IDENTIFICATION

MCO-E-5 Door Components

ITEM	PART #	DESCRIPTION	QTY	DATE	
				FROM	UP TO
1	1380896	Door Frame	1		18-Jun-99
	1946899	Door Frame	1	18-Jun-99	
2	CK1757998	Latch Bench Assembly	1	31-Jan-03	
3	1902918	7.5" Garland Nameplate	1		1-Oct-01
	3077100	Nameplate Garland 7-5/8		1-Oct-01	
4	1562604	Door Handle End Lt	1		
5	1562605	Door Handle End Rt - Bottom	1		
6	1664801	Door Handle	1		
10	1010999	Oven Door Window (3/16 Glass)	1		
11	1023801	Window Hold Down Strap	2		
12	1663201	Handle Backer Plate	1		
13	1770301	Door Panel	1		
14	1770396	Door Liner With Window	1		
	1770397	Door Liner Without Window			
15	1750501	Door Catch	1		
16	1769801	Right Side Trim	1		
18	1904002	Activating Bracket	1	23-Jun-98	
19	1904099	Activating Rod	1		
20	1904001	Micro Switch Bracket	1		
21	1019600	Door Safety Micro Switch	1		
22	1770101	Right Door Seal	1		
23	1770201	Top Door Seal	1		
24	1946804	Microswitch Bracket	1		
25	1582198	Front Frame 1/2 CO Weld Assembly	1		
26	1379901	Front Base Channel	1		
27*	1385499	Hinge Bracket Top Assembly	1		15-Apr-02
28*	1385498	Hinge Bracket Bottom Assembly	1		
29	1385500	Door Bearing Retainer Top	1		
	1385501	Door Bearing Retainer Bottom	1		
30	1385497	Hinge Bracket Assembly	2		
32	1946801	Microswitch Activator	1	18-Jun-99	
33	1770001	Left Door Seal	1		
34	1770202	Bottom Door Seal	1		
36*	8020203	Fastener - 1/4-20	2		
37*	8003800	Handle Set Screws	2		

Kits Available

50*	1770399	<i>MCO-E-5 Door With Window Includes Items: 1 to 14</i>			
60*	1770398	<i>MCO-E-5 Door Without Window Includes Items: 1 to 14</i>			

* NOT ILLUSTRATED

RECOMMENDED STOCK PARTS

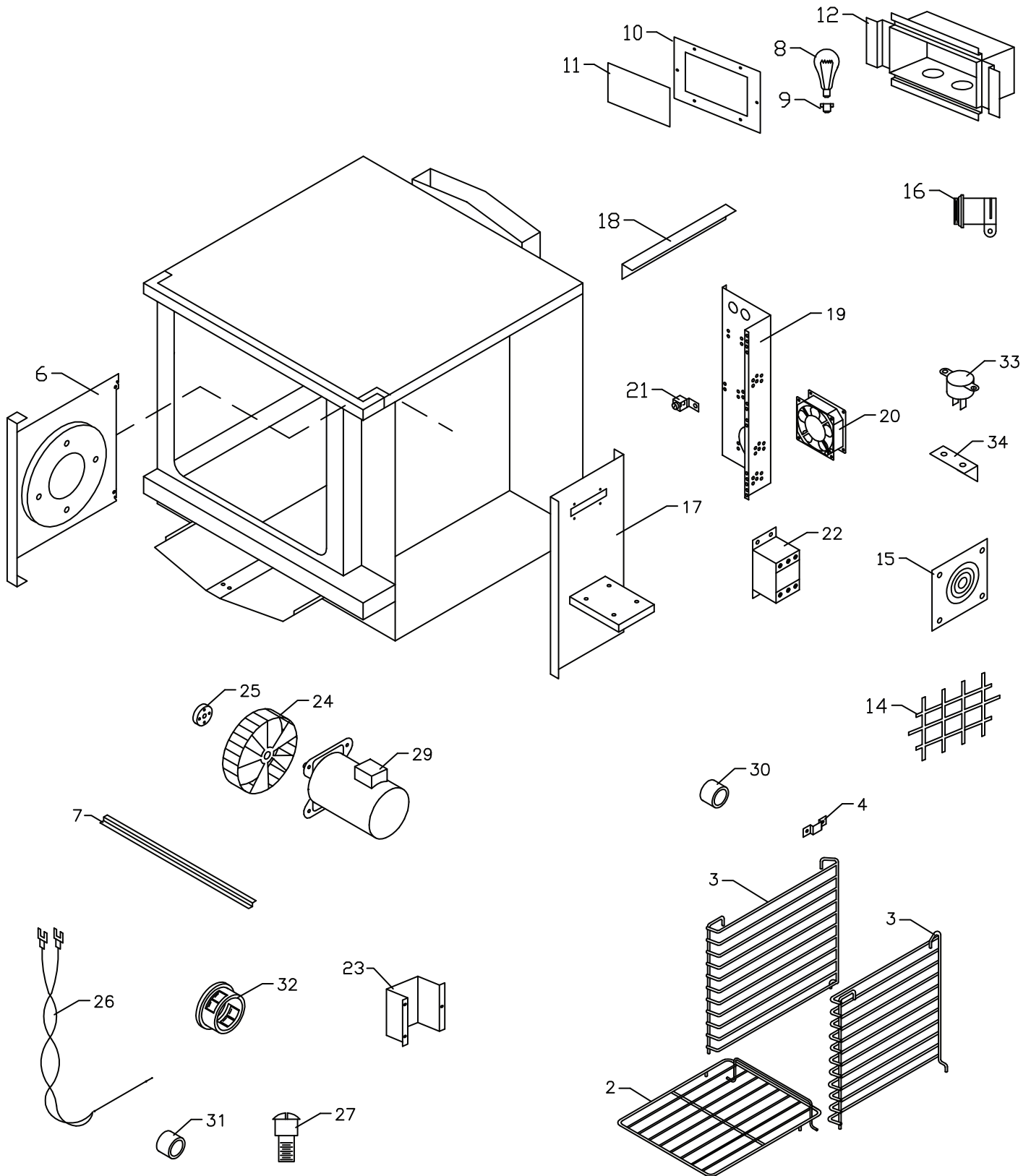

Oven Components (electric)

GARLAND PARTS IDENTIFICATION

MCO-E-5 Oven Components

ITEM	PART #	DESCRIPTION	QTY	DATE	
				FROM	UP TO
2	1766001	Oven Rack Std.	5		
		Oven Rack(TJ Cinnamon Only)			
		Oven Rack (Tim Horton Only)			
3	1766002	Rack Guide Std.	2		
	1846301	Rack Guide (TJ Cinnamon Only)			
	1766003	Rack Guide (Tim Horton Only)			
4*	1765202	Rack Mounting Clip	8		
5*	1770906	Oven Liner Left Side	1		
	1770909	Oven Liner Right Side			
	1770903	Oven Liner Back			
	1770913	Oven Liner Back With Light			
6	1765299	Air Baffle Electric	1	25-Jan-00	
7	1765601	Air Baffle Front Support	1		
8	1623900	Light Bulb 40W	2		
9	1025800	Lamp Socket - Porcelain	2		
10	1847203	TJ Light Glass Cover Frame	1		
11	1676902	TJ Light Glass Frosted	1		
12	1847202	TJ Light Box	1		
13*	1025900	Light Socket Gasket	2		
14	G02904-01P	Blower Inlet Cover	1		
15	1032504	Knock Out Plate GG	1		
	1032500	Knock Out Plate SS (Std & TJ)			
16	1028501	3/8 BX Straight Connector	1		
17	1772799	Motor Support	1		
18	1770501	Motor Support Spacer	1		
19	1769901	Screen	1		
20	1774001	Fan - 80MM, 230V AC 50/60HZ	1		
	1918202	Fan - 110MM, 208/240V		18-Oct-99	01-Dec-03
21	1028402	Ground Lug	1		
22	1637002	Contactactor 240V Coil	1	3-Oct-02	
23	1765501	Element Cover	1		
24	1765704	Blower Wheel Complete	1		
25	1765702	Wheel Puller	1		
26	9006800	Probe Tube	1	22-Jan-03	
27	1166901	10-24 X 1/2 Shoulder Bolt			
29	1773802	Motor 208/240V - 2 Speed	1	16-Nov-95	
30	1011201	Steel Tubing Chrome Spacer	2		
31	1765204	Rack Hold Down (Brass)	1		
32	1028800	Snap Bushing 1.000 Dia.	3		
	1028803	Snap Bushing 1.750 Dia.	1		
33	1955101	Switch Thermal Disc (Cooling Fan)	1		
34	1910901	Thermal Disc Bracket	1		
35*	1905901	Harness Control to Relay Board	1		

* NOT ILLUSTRATED

RECOMMENDED STOCK PARTS

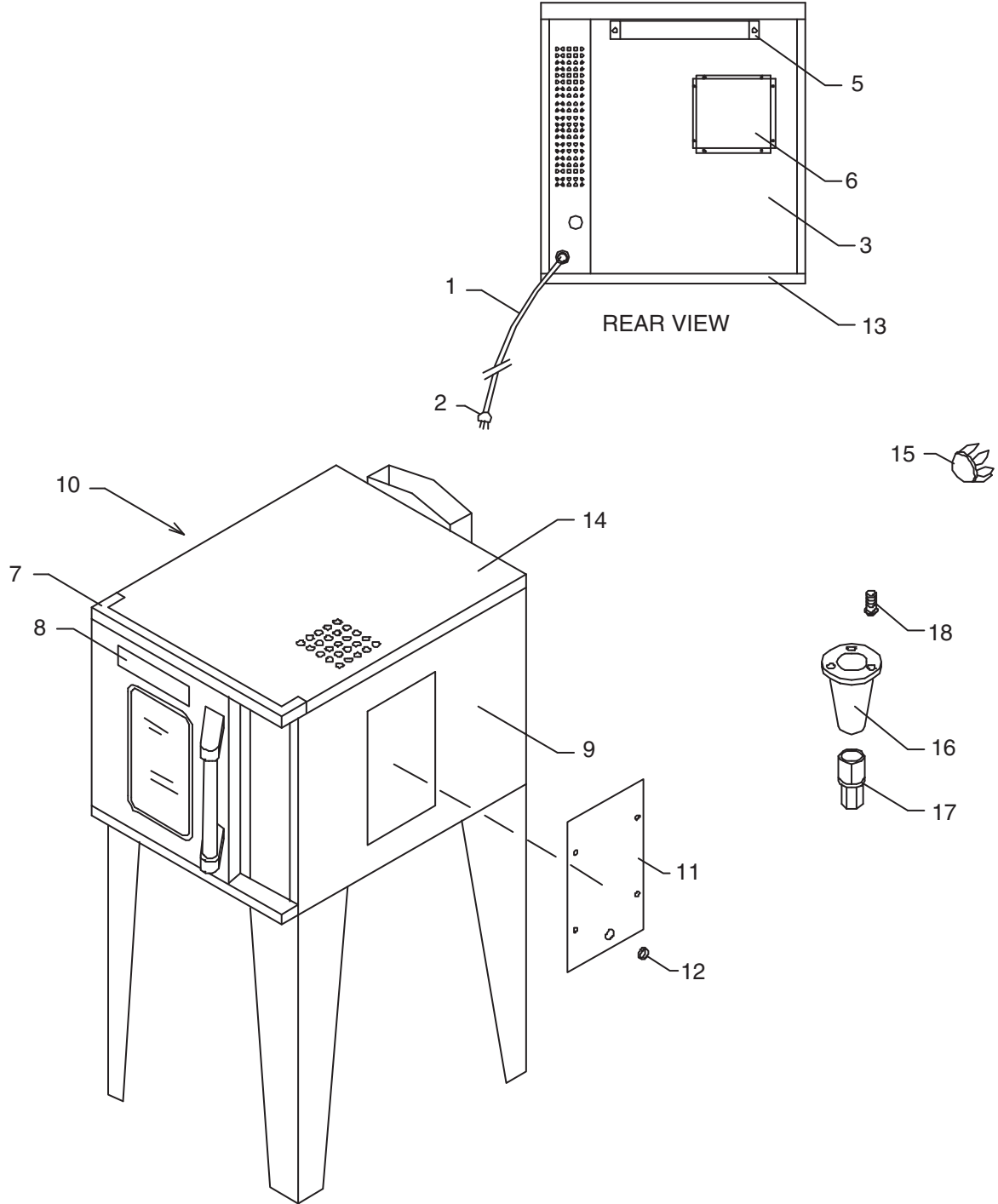

GARLAND PARTS IDENTIFICATION

MCO-E-5 Main Exterior

ITEM	PART #	DESCRIPTION	QTY	DATE	
				FROM	UP TO
1	1834505	8' Long Power Supply Cord 600V 40 Amps	1		
2	1834501	Plug 50 A 250 V	1		
	1834503	Plug 30A 3 Ph 250V	1		
3	1773301	Main Back AZ	1		
	1773302	Main Back SS	1		
	1773303	TJ Main Back AZ	1		
4*	1379103	Main Back Screen Cover - 6x18.5 (Std & TJ)	1		
	1379104	Main Back Screen SS 6x18.5	1		
5	1380200	Flue Box AZ (Std & TJ)	1	4-Jun-02	
	1380201	Flue Box SS	1		
	1380202	Flue Box GG-TJ	1		
6	1847201	Light Box Cover	1		
7	1385300	Main Top Front Veneer - S/S	1		
8	1902918	7.5 " Garland Nameplate	1		1-Oct-01
	3077100	Nameplate Garland 7-5/8	1	1-Oct-01	
9	1381405	Body Side Right SS	1		
10	1381402	Body Side Left SS	1		
11	1770401	Right Side Access Cover SS	1		
12	1143600	1" Nickel Plated Finger Ring	1		
13	1381898	Main Bottom Assembly	1		
14	1381397	Main Top Assembly SS	1		
15	1038000	Plug Button	1		
16	1027603	Standard 4" Leg Cone	4		
17	1150501	Bullet Leg	4		
18	8002413	Screws	12	26-Sep-00	

Kits Available

30*	CK00-002	4" Leg Kit	1		
-----	----------	------------	---	--	--

* NOT ILLUSTRATED

RECOMMENDED STOCK PARTS

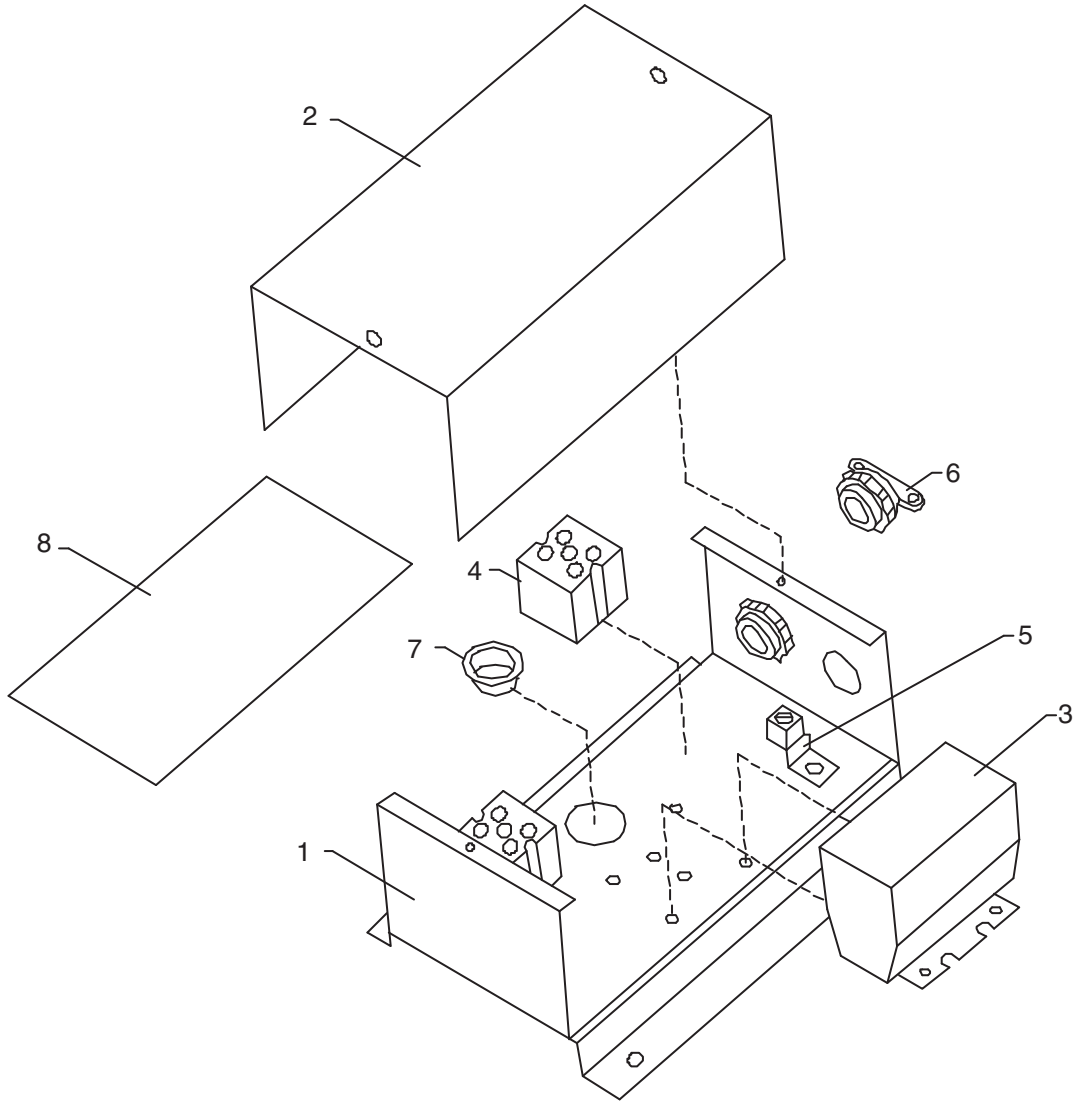

**GARLAND PARTS IDENTIFICATION
MCO-E-5 HOOD INTERLOCK COMPONENTS**

ITEM	PART #	DESCRIPTION	QTY	DATE	
				FROM	UP TO
1	1966101	Hood Interlock Relay Board	1		
2	1966102	Hood Interlock Relay Cover	1		
3	1772801	30 Amps Single Pole Contactor	1		
4	1772901	Mini 2 Pole Terminal Pole	1		
5	1028402	Ground Lug	1		
6	1028501	3/8 BX Straight Connector	1		
7	1028809	Snap Bushing .875 Dia.	1		
8	1772401	Label Card Control	1		
9*	1104300	Label Ground Symbol	1		
10*	1807859	Hood Interlock MCO-E-5 Diagram			

* NOT ILLUSTRATED

RECOMMENDED STOCK PARTS

GARLAND PARTS IDENTIFICATION

Revision History

REV. #	PAGE #	ITEM #	NOTE	DATE
0			Part List Book Completed	April 17/03
1	5	25	Part Location Added	May 5/03
	9	21		
2	5	4	Part# 1130108 (Fuse) Replaced by 4513157 (Fuse)	April 23/03
	9	20		
	11, 13	17		
3	16		Item 35 deleted	Dec 18/03
	17	35	Part # deleted (1750501)	
4	19	14	Part # Changed – Was 1014500	May 25/05
		20	Part # 1918201 deleted (Part # 1918202) Up to Date 1-Dec-2003 Added	
		33	Part # Changed – Was 1781302	
		33,34	New Description	
5	6,7	27,28	Switch Thermal Disc (Cooling Fan) And Bracket Part Numbers Added	Nov 16/05
	8,9	26,27		
	10,11			
	12,13		New Drawing	

Bulletin Related To This Parts List Book

Bulletin Number	Subject	Date
B-60-2001	Garland 1/2 size convection oven control panel field service kits	May 28/01

NOTES

NOTES

NOTES

 **GARLAND**[®]