



INSTALLATION AND OPERATION MANUAL

**GARLAND GAS & ELECTRIC
CLAMSHELL GRILLS
WITH PRODUCT RECOGNITION**

MODELS:

MWE3W

MWE3S

MWG3W



WARNING:

IMPROPER INSTALLATION, ADJUSTMENT, ALTERATION, SERVICE OR MAINTENANCE CAN CAUSE PROPERTY DAMAGE, INJURY OR DEATH. READ THE INSTALLATION, OPERATING AND MAINTENANCE INSTRUCTIONS THOROUGHLY BEFORE INSTALLING OR SERVICING THIS EQUIPMENT.

PLEASE READ ALL SECTIONS OF THIS MANUAL AND RETAIN FOR FUTURE REFERENCE.

THIS EQUIPMENT **MUST** BE INSTALLED AND COMMISSIONED BY A PROFESSIONAL, FACTORY-TRAINED TECHNICIAN.

THIS EQUIPMENT MUST BE OPERATED UNDER AN APPROVED HOOD SYSTEM ONLY.

NOTE: This manual pertains to all grill models listed above. The reader/operator must interpret its contents to applicable needs. If you have questions about any instructional materials pertaining to Garland grills, please contact our Customer Service Department at one of the phone numbers below.

MANUFACTURED EXCLUSIVELY FOR McDonald's BY
GARLAND COMMERCIAL INDUSTRIES, LLC
185 EAST SOUTH STREET FREELAND, PENNSYLVANIA 18224
TOLL FREE: (800) 446-8367 PHONE: (570) 636-1000 FAX: (570) 636-9874
E-mail: clamshell@garland-group.com
<http://www.garland-group.com>

CONTENTS

INTRODUCTION..... 4

WARRANTY..... 4

SAFETY..... 5

SHIPPING DAMAGE CLAIM PROCEDURE..... 6

CLEANING & MAINTENANCE 6

SPECIFICATIONS 8

INSTALLATION 12

INSTALLATION OF RELEASE MATERIAL..... 17

INSTALLATION OF SPLASH SHIELD 18

GRILL ACCESSORIES 19

OPERATING INSTRUCTIONS 20

DESCRIPTION OF GRILL CONTROL 21

POSSIBLE ERROR MESSAGES 21

OPERATING PROCEDURES 22

 General Overview:.....22

 To turn the grill on:22

 To Select a Menu item:.....22

 Menu Item Library.....22

 Indicator Lights.....23

 Standby Mode.....23

 To Exit the Standby Mode:23

 To Display the Current Temperatures23

 Cooking Procedures in manual Mode BREAKFAST.....23

 Cooking Procedures in manual Mode LUNCH.....23

 To Change the Cook Time for a Menu Item.....23

 AUTO Mode (Product Recognition) BREAKFAST24

 AUTO Mode (Product Recognition) LUNCH24

 Patty Placement24

PRODUCT RECOGNITION..... 24

PROGRAM LOGIC..... 25

CONTROL PROGRAMMING 26

 Programming Modes; System Setup26

 Programming Modes; Menu Items27

PROBE CALIBRATION 30

THERMOCOUPLE LOCATIONS 30

MENU ITEM PARAMETERS 31

PROGRAMMING: SYSTEM FUNCTION OPTIONS 32

TEMPERATURE CONVERSION CHART 33

INTRODUCTION

The Garland clamshell grill, manufactured exclusively for McDonald's, provides a method for efficient two-sided cooking, while accommodating a variety of products. The unit will also serve as a flat grill, and meets all of McDonald's standards for safety, efficiency, and cleanliness.

WARRANTY

This warranty covers defects in material and workmanship under normal use providing that:

- a) the equipment has not been accidentally or intentionally damaged, altered or misused.
- b) the equipment is properly installed, adjusted, operated and maintained in accordance with national and local codes and in accordance with the installation instructions provided with this product.
- c) the warranty serial number affixed to the appliance by us has not been defaced, obliterated or removed.
- d) an acceptable report for any claim under this warranty is supplied to us.

The equipment warranty coverage remains in force for two (2) years, (parts and labor), from the date the equipment is put into operation.

The Garland Group agrees to repair or replace, at it's option, any part that proves to be defective in material or workmanship at no charge for the part or normal labor.

We assume no responsibility for installation, adjustments, diagnosis, or normal maintenance such as: lubrication of springs or valves. We exclude failures caused by erratic voltage or gas supplies.

We assume no responsibility for travel costs beyond 100 miles round trip, travel other than overland, and overtime costs of repair.

We exclude broken glass, paint and porcelain finish, surface rust, gasket material, ceramic material, light bulbs and fuses from normal coverage.

We exclude damage or dysfunction caused by fire, flood, and like "Acts of God" that are beyond the control of The Garland Group.

The Garland Group's liability on a claim of warranty shall not exceed the price of the material and/or service, which caused the claim.

This warranty is limited and is in lieu of all other warranties, expressed or implied. The Garland Group, our employees, or our agents shall not be held liable for any claims of personal injury or consequential damage or loss.

This warranty gives you specific legal rights, and you may have other rights which vary from state to state.

SAFETY

THIS APPLIANCE IS FOR PROFESSIONAL USE AND SHALL BE USED ONLY BY QUALIFIED PERSONNEL.

WARNING: Accessible parts may become hot during use. Young children should be kept away. This appliance is not intended for use by persons (including children) with reduced physical, sensory or mental capabilities, or lack of experience and knowledge, unless they have been given supervision or instruction concerning use of the appliance by a person responsible for their safety.”

CAUTION: THIS EQUIPMENT MUST ONLY BE OPERATED UNDER AN APPROVED HOOD SYSTEM IN ACCORDANCE WITH LOCAL REGULATIONS IN FORCE.

DO NOT OPERATE THE GRILL UNLESS IT HAS BEEN COMMISSIONED (START-UP) BY A FACTORY AUTHORIZED SERVICE CENTER.

DO NOT operate the grill without reading this operation manual.

DO NOT operate the clamshell grill unless it has been properly installed and grounded.

DO NOT operate the clamshell grill unless all service and access panels are in place and fastened properly.

Means of disconnection, must be incorporated in the fixed wiring in accordance with local wiring rules (such as a switch, fuse, or circuit breaker). External equipotential bonding conductor provided on rear of appliance. Use as applicable, in accordance with local wiring rules.

The Garland clamshell grill is a semi-automatic cooking appliance. The upper platen is lowered automatically, following the manual, single-handed initiation of the cooking cycle, and raised automatically upon completion of the cooking cycle.

When two sided cooking, the area between the upper platen and the griddle plate should be regarded as a “danger zone”. During two sided cooking the operator must not be within this danger zone. When used as a flat grill, then this area is no longer a danger zone, the platens do not move. For whatever reason, be it cleaning, maintenance, normal operation, any exposed person must use extreme caution if within this danger zone. Temperatures on solid cooking surfaces are intended to operate above 120C (250F).

In two sided cooking the upper platen remains in the lowered position by nature of it’s own weight. It is not locked down. It can be raised by lifting of the handle on the front of the platen, which pivots the platen about its rear mounting point.

The clamshell grill must only be used for single and two sided cooking of foodstuffs in a McDonald’s store.

WARNING: To avoid serious personal injury: **DO NOT** attempt to repair or replace any part of the clamshell grill unless all main power supplies to the grill have been disconnected.

USE EXTREME CAUTION in setting up, operating and cleaning the clamshell grill to avoid coming in contact with hot grill surfaces or hot grease. Suitable protective clothing should be worn to prevent the risk of burns.

WARNING: This appliance must not be cleaned with a water jet. **DO NOT** apply ice to a HOT grill surface.

NOTE: All warning labels and markings on the grill, which call attention to further dangers and necessary precautions.

HAZARD COMMUNICATION STANDARD, (HCS) - The procedures in this manual include the use of chemical products. These chemical products will be printed in **bold face**, followed by the abbreviation **(HCS)** in the text portion of the procedure. See the Hazard Communication Standard, (HCS) manual for the appropriate Material Safety Data Sheet(s), (MSDS).

WARNING: After turning the master power switch to the START position, the grill will go through an initialization process. If the upper platens are in the lowered position they will return to their raised upper position.

MAINTENANCE - the platen support arms carriage block bearing bushes, the platen adjuster nuts, the platen support (shoulder) bolt and the cam follower should be checked annually for wear. Should there be any noticeable play in the bearing bushes and any visible wear on the platen adjuster nuts, platen support bolts or cam follower, then they must be replaced.

MAINTENANCE - the audible alarm that sounds at the end of a cook cycle is to advise the operator that the platen is about to move. The function of this device may be tested by pushing the left hand CANCEL button. If no sound is heard, ensure that the alarm volume is not set to low in SYSTEM SETUP. If there is still no sound then a service engineer should be called out to rectify the fault.

SERVICE AND CLEANING - The grill may be secured in the grill bay by the installer using two anchors that lock onto the front casters. If the grill is to be moved out of the bay for cleaning or service, remove the anchor from each caster by turning the knob counterclockwise to loosen the retainer. When the retainer is free of the caster, lay the assembly aside on the floor.

CLEANING - NEVER clean the grill, interior or exterior, using a high-pressure sprayer, water jet, or any other liquid sprayer.

NOTE: If anchors are present, the anchor assembly remains fastened to the back wall of the grill bay. After service or cleaning is complete, return the grill to its position in the bay and reattach the anchors by placing the retainer on the caster post and turning the knob clockwise to tighten. For safety reasons, the grill must be secured in the grill bay in this manner before operation can resume.

SHIPPING DAMAGE CLAIM PROCEDURE

Please note that the Garland equipment was carefully inspected and packed by skilled personnel before leaving the factory. The transportation company assumes full responsibility for safe delivery upon acceptance of the equipment. What to do if the equipment arrives damaged:

1. File a claim immediately regardless of the extent of damage.
2. Be sure to note, "visible loss or damage," on the freight bill or express receipt and have the person making the delivery sign it.
3. Concealed loss or damage: if damage is unnoticed until the equipment is unpacked, notify the freight company immediately, (within 15 days), and file a concealed damage claim.

CLEANING & MAINTENANCE



The following information is also available on the **McDonalds MRC Card 11A**.

Tools: McD Hi-Temp Grill Cleaner (HCS), McD All Purpose Super Concentrate (HCS), McD's NOSCRATCH™ Pad and Pad Holder, a suitable container, High-Temperature Pot Brush and Grill Cloth, Stainless Steel Pan Filled With Lukewarm Water, Protective Gloves, (to protect hands from heat), Grill Squeegee and Grill Scraper.

Warning: The upper platen surface and edges are very hot! To prevent burn injuries, use extreme caution when wiping down release sheets and platen edges.

Important: Frequently throughout the day, (at least 4 times per hour), thoroughly wipe down the release sheets and platen edges with a damp grill cloth.

1. Select Manual mode using the  button.

PRESS the  OR  arrow buttons until "CLEAN MODE" is displayed, (the control will maintain the proper cleaning temperature).

Repeat with the other control. "READY TO CLEAN" will be displayed and an audible alarm will sound when the grill is at the proper cleaning temperature.

Press the  GREEN pushbutton to display "OFF." The "OFF" position on the controller allows the operator to raise and lower the platen, (for clamshell grills), to alternate positions for cleaning of the platen edges.

2. Empty and replace the grease troughs. Grease troughs should be emptied and replaced consistent with store security policy.
3. Put on the protective gloves and wipe down the exposed surface of the release sheet with a damp grill cloth.

4. Remove the release sheet locking clips and bars. Clean the release sheets following the instructions provided by your local cleaning chemical supplier.
5. Scrape only the lower grill surface with the grill scraper, and squeegee any residue into the grease troughs with the grill squeegee.

Caution: Do not scrape or otherwise scratch the upper platens. The use of metal scrapers, abrasive pads, or wire brushes will permanently damage the surface of the upper platens.

6. Open one packet of McD Hi-Temp Grill Cleaner, (HCS), and empty the contents into a suitable container. (One packet cleans a 3ft. grill).
7. Firmly attach the McD NO-SCRATCH™ Pad to the pad holder.
8. Dip the NO-SCRATCH™ Pad into the grill cleaner.
9. Spread a light coating of grill cleaner over the entire platen surface, BACK, FRONT AND SIDE EDGES of all upper platens. DO NOT SCRUB WHILE APPLYING THE PRODUCT.
10. After applying the grill cleaner, lightly scrub the platen surfaces, BACK, FRONT AND SIDE EDGES with the NO-SCRATCH™ Pad until all the soil has been liquefied by the grill cleaner. For stubborn soils, apply additional grill cleaner and lightly scrub. DO NOT RINSE THE PLATENS AT THIS TIME.
11. Starting at the back of the lower grill, spread a light coating of grill cleaner over the entire surface. DO NOT SCRUB WHILE APPLYING THE PRODUCT.
12. After applying the grill cleaner, lightly scrub the grill surface with the NO-SCRATCH™ Pad until all the soil has been liquefied.

CLEANING & MAINTENANCE *continued*

13. Rinse the upper platens with a dripping wet grill cloth. RINSE PLATEN EDGE THOROUGHLY, THEN WIPE DOWN BACK EDGE OF PLATEN.
14. Carefully pour small quantities of lukewarm water onto the grill while brushing the surface, backsplash, and bullnose with a LONGLIFE™ pot brush or equivalent high-temperature brush. Continue until the water no longer boils away and the grill remains wet. Squeegee dry.

Caution: Ice, cold water, or large quantities of water must never be applied to the grill plate or upper platen. Severe damage to the grill will occur!

15. Clean the release sheets as follows:
16. Place the sheets on the lower grill. Scrub both sides of the sheets with the same McD NO-SCRATCH™ Pad used on the grill.

Note: It is generally not necessary to apply additional product to the NO-SCRATCH™ Pad. If the pad is not wet enough rewet with a small amount of water, if no cleaner is left.

- a. Rinse both sides of the sheets with a wet grill cloth.
- b. Rinse the lower grill by flooding the surface twice with lukewarm water. Squeegee after each rinse.

17. Wipe the lower grill surface, backsplash, bullnose, and hood with a clean, damp grill cloth.

AFTER CLEANING: Apply a thin coat of fresh shortening to the lower grill surface only. Wipe down the surrounding areas. Empty, wash, rinse, and replace the grease troughs.

Note: Repeat this procedure to clean additional grills.

Reverse NO-SCRATCH™ Pad, and use clean side.

CLEANING AFTER EACH RUN OF PRODUCT:

Using grill scraper, scrape grease on lower grill plate from front to back only. Do not scrape across the rear of the lower grill plate with grill scraper. Use wiper squeegee to clean release material sheet on upper platen in a downward motion.

Hold handle at a slight upward angle with wiper end facing downward. Do not press hard against the release material sheet to prevent scratching or tearing.

Push the grease at the rear of the lower grill plate into the grease cans using the wiper squeegee only. Do not use the grill scraper for this step.

Warning: Grill Temperatures will cause severe skin burns.

Use the grill cloth to clean back splash and bullnose areas as needed during operation.

Note: To increase life of release material sheet, wipe down with folded grill cloth four (4) times every hour.

SPECIFICATIONS

Dimensions: Models MWE3W, MWG3W

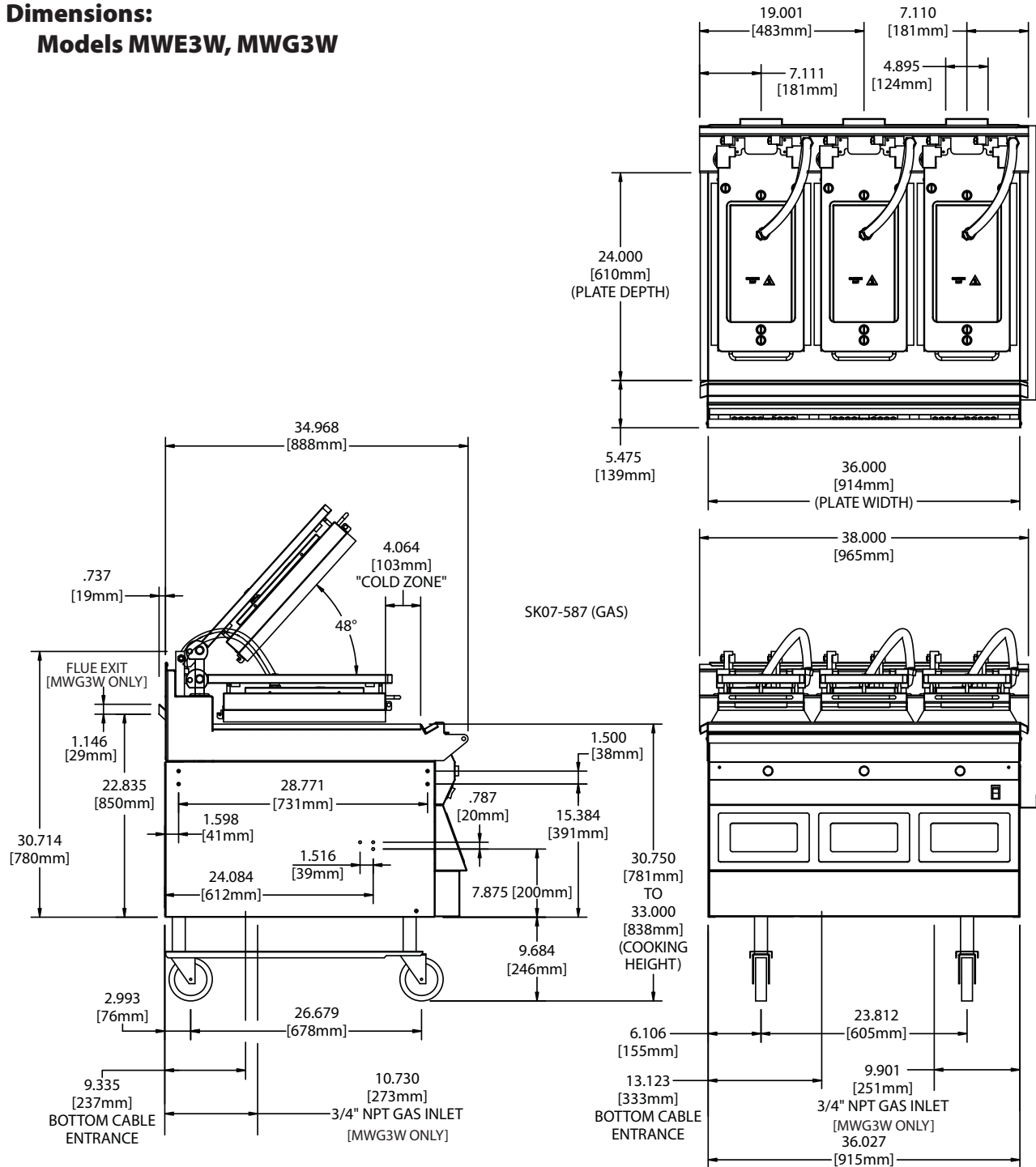

SPECIFICATIONS

Dimensions: Model MWE3S

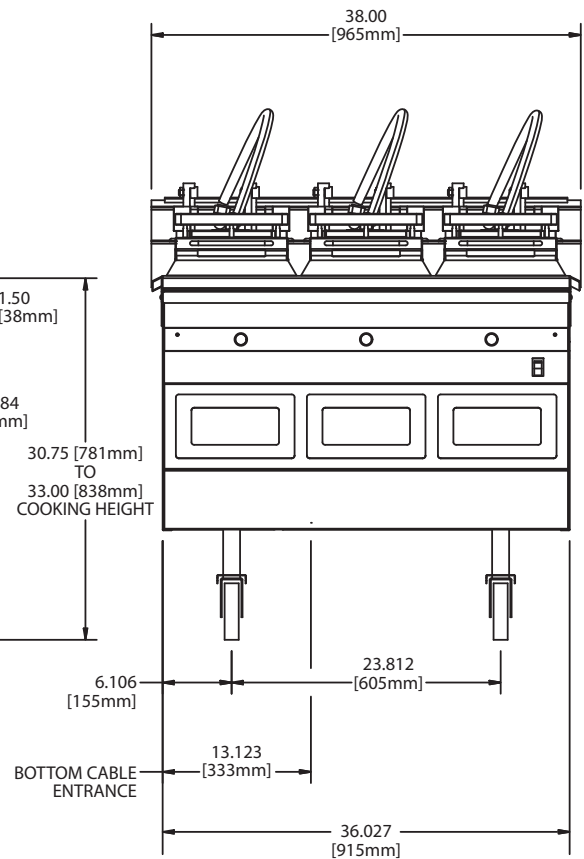
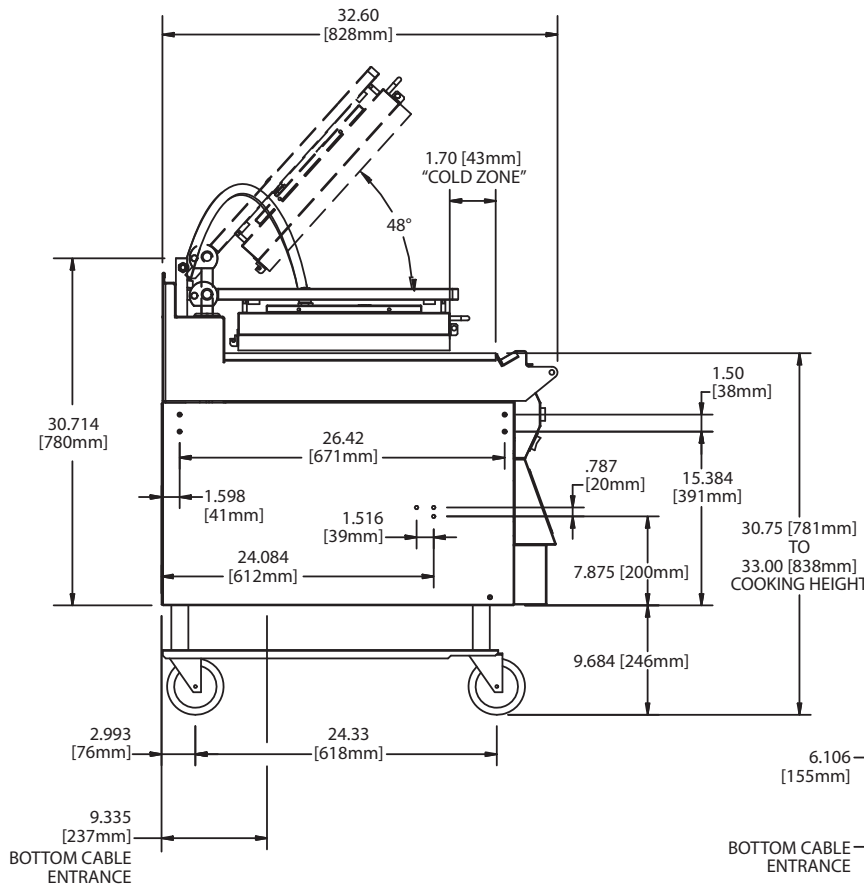
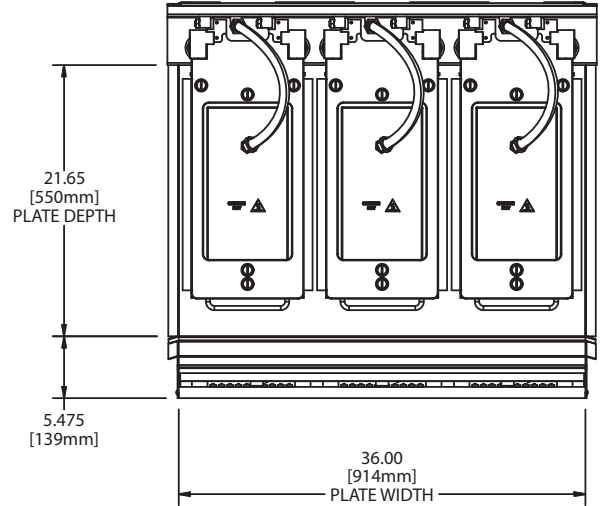

SPECIFICATIONS

Input Specifications, Electric Grills, United States:

(2) 50-AMP CIRCUITS & INTERLOCK	TOTAL kW LOAD	LOADING: (kW/PHASE)			NOMINAL AMPS PER LINE									NEMA RECEPTACLE REQUIRED
		208V / 220V / 240V			208V / 60Hz			220V / 60Hz			240V / 60Hz			
		L1/L2	L1/L3	L2/L3	L1	L2	L3	L1	L2	L3	L1	L2	L3	
INPUT 1	7.65	2.55	2.55	2.55	21.3	21.3	21.3	20.1	20.1	20.1	18.4	18.4	18.4	15-50R
INPUT 2	15.30	5.10	5.10	5.10	42.6	42.6	42.6	40.2	40.2	40.2	36.8	36.8	36.8	15-50R

INTERLOCK	HVAC Hood / Fire Suppression Interlock Circuit: 7 Amps / 120V / Single Phase	L21-20R
------------------	--	---------

Input Specifications, Electric Grills, Canada:

(1) 50-AMP CIRCUIT	TOTAL kW LOAD	LOADING: (kW/PHASE)			NOMINAL AMPS PER LINE						NEMA RECEPTACLE REQUIRED
		208V / 220V / 240V			208V / 60Hz			240V / 60Hz			
		L1/L2	L1/L3	L2/L3	L1	L2	L3	L1	L2	L3	
	22.95	7.65	7.65	7.65	63.9	63.9	63.9	55.2	55.2	55.2	15-50R

INTERLOCK	HVAC Hood / Fire Suppression Interlock Circuit: 7 Amps / 120V / Single Phase	L21-20R
------------------	--	---------

Input Specifications, Electric Grills, CE Approved Models MWE3W-CE, MWE3S-CE:

SUPPLY	TOTAL kW LOAD	LOADING: (kW/PHASE)			NOMINAL AMPS PER LINE			MENNEKES PLUG REQUIRED
		230V / 400V			230V / 400V			
		L1/L2	L1/L3	L2/L3	L1	L2	L3	
3N~ 400V 50Hz	22.7	7.60	7.60	7.60	33.0	33.0	33.0	Type 748

Input Specifications, Electric Grills, Export, Non-CE Models MWE3W, MWE3S:

SUPPLY	TOTAL kW LOAD	LOADING: (kW/PHASE)			NOMINAL AMPS PER LINE			MENNEKES PLUG REQUIRED
		230V / 400V			230V / 400V			
		L1/L2	L1/L3	L2/L3	L1	L2	L3	
220V 50Hz	22.7	7.60	7.60	7.60	34.5	34.5	34.5	Type 748
240V 50Hz	22.7	7.60	7.60	7.60	31.6	31.6	31.6	

Input Specifications, GAS Grills, Japan:

ELECTRICAL INPUT							
SUPPLY REQUIRED	TOTAL kW LOAD	LOADING: (kW/PHASE)			NOMINAL AMPS PER LINE		
		200V / 60Hz			200V / 60Hz		
		L1/L2	L1/L3	L2/L3	L1	L2	L3
SINGLE INPUT	9.01	3.0	3.0	3.0	26.0	26.0	26.0

GAS INPUT SAME AS NORTH AMERICA (see next page)

SPECIFICATIONS

Input Specifications, GAS Grills, North America:														
ELECTRICAL INPUT														
(1) 30-AMP CIRCUIT & INTERLOCK	TOTAL kW LOAD	LOADING: (kW/PHASE)			NOMINAL AMPS PER LINE									NEMA RECEPTACLE REQUIRED
		208V / 220V / 240V			208V / 60Hz			220V / 60Hz			240V / 60Hz			
		L1/L2	L1/L3	L2/L3	L1	L2	L3	L1	L2	L3	L1	L2	L3	
INPUT 1	10.0	3.25	3.25	3.25	28.0	28.0	28.0	26.3	26.3	26.3	24.0	24.0	24.0	15-30R
INTERLOCK	HVAC Hood / Fire Suppression Interlock Circuit: 7 Amps / 120V / Single Phase												L21-20R	
GAS INPUT														
GAS	MAX INPUT (NET) PER BURNER (BTU/H)	TOTAL INPUT RATING (BTU/H)	INJECTOR SIZE	AIR SHUTTER SETTING (MM)	SUPPLY PRESSURE (IN W.C.)	BURNER MANIFOLD PRESSURE (IN W.C.)								
NATURAL GAS	32,000	96,000	#35	4.8	3.5	3.5								
PROPANE	32,000	96,000	#43	4.8	3.5	10.0								

Input Specifications, GAS Grills, CE Approved Model MWG3W-CE:									
ELECTRICAL INPUT									
3N~ 400V 50Hz	TOTAL kW LOAD	LOADING: (kW/PHASE)			NOMINAL AMPS PER LINE			MENNEKES PLUG REQUIRED	
		L1/L2	L1/L3	L2/L3	L1	L2	L3		
	10.0	3.25	3.25	3.25	14.1	14.1	14.1	Type 748	
GAS INPUT									
GAS GROUP	MAX INPUT (NET) PER BURNER (kW)	TOTAL INPUT RATING (kW)	INJECTOR SIZE	AIR SHUTTER SETTING (mm)	SUPPLY PRESSURE (mbar)	BURNER PRESSURE (mbar)	VOLUMETRIC GAS RATE		
G20 NG	8.9	26.7	2.79mm (#35)	4.8	20/25	8.7	0.940 m ³ /h		
G25 NG			2.79mm (#35)	4.8	20	8.7			
G31 LPG	8.9	26.7	2.26mm (#43)	4.8	37/50	8.7	0.69 kg/h		
NET HEATING VALUE BY GAS GROUP									
G20			G25			G31			
34.02 MJ/m ³ ; 0.555 SG			29.25 MJ/m ³ ; 0.613 SG			88.0 MJ/m ³ (46.34 MJ/kg); 1.55 SG			
GAS CATEGORIES									
CATEGORY	DESTINATION COUNTRIES							SUPPLY PRESSURE (mbar)	
I _{2H}	AT, CH, CZ, DK, ES, FI, GB, IE, IS, IT, NO, PT, SE							20.0	
I _{2E}	DE, LU							20.0	
I _{2L}	NL							25.0	
I _{2ER}	FR							20.0 / 25.0	
I _{3P}	NL							30.0	
I _{3P}	BE, CH, CZ, ES, FR, GB, GR, IE, LU							37.0	
I _{3P}	BE, CH, DE, CZ, ES, FR, NL							50.0	

INSTALLATION & STARTUP

Installation Store Responsibilities:

- Ensure grill has been installed by a competent trained installation person.
- Ensure store readiness of utilities, product & personnel.
- Contacting your local Garland Factory Authorized Service Center for a start up date.
- Participate in the start up to ensure a successful start up and familiarity with the grill.
- Conduct training with your crew personnel to ensure maximum utilization of the grill.

Once the installation is complete as per the procedures below, a factory authorized service company MUST start up the grill according to Garland Commercial Industries start up standards.

A Start-Up DOES NOT include:

1. Uncrating the unit
2. Placing the unit in its position under the hood.
3. Leveling the grill on the floor under the hood.
4. Attaching the supply cord(s) unless supplied by the factory.
5. Making adjustments to the ventilation system.
6. Sheet metal work required due to improper hood application.
7. Adjusting the grill to achieve beef integrity that deviates from the McDonalds standard.

A start-up DOES include:

1. Verification of supply voltage and, if applicable gas supply.
2. Leak test and gas pressure check on gas grills.
3. Electrical safety check.
4. Verify operation of grill by allowing unit to attain set temperature.

5. Verify operation of platens, if applicable, and timer functions.
6. Ensure time out alarm is functional and platens raise (if applicable)
7. Set proper gas and verify with beef integrity check that two consecutive runs yield the approved beef integrity results as per McDonalds standards.
8. Conduct brief training to store manager on the operation of the grill.

Items included with the purchase of your new grill from Manufacturer:

1. Grill
2. Gas Hose (For gas grills only)
3. One (1) box containing:
 - a. Six (6) Teflon sheets
 - b. Three (3) Teflon front clips
 - c. Three (3) Rear rods.
4. One (1) box containing four (4) casters.

Items NOT INCLUDED from the manufacturer and should be purchased from the KES:

1. Electrical Cords
2. Flue Box
3. Grease traps & rails

THE FOLLOWING INSTALLATION PROCEDURE CAN BE PERFORMED BY A:

- FACTORY AUTHORIZED SERVICE CENTER
- AN APPROVED INSTALLATION PERSON APPROVED BY PURCHASER OF GRILL
- LICENSED INSTALLER CONTRACTED BY KES (KITCHEN EQUIPMENT SUPPLIER)

WARNING: PLEASE READ INSTALLATION INSTRUCTIONS CAREFULLY. FAILURE TO PERFORM THESE STEPS CAN RESULT IN EQUIPMENT FAILURE, DAMAGE AND / OR VOID OF WARRANTY.

INSTALLATION & STARTUP *(continued)*

1. Uncrate unit from crating material

IMPORTANT: RATING PLATE FOR THIS EQUIPMENT IS LOCATED IN TWO PLACES. ONE IS LOCATED INSIDE BACK PANEL ON LEFT SIDE, SECOND RATING PLATE LOCATED UNDER FRONT CONTROL PANEL IN CENTER.

CAUTION: Prior to installation, check the electrical supply to ensure input voltage and phase match the equipment voltage rating and phase. See data plate located rear left side of grill. Back panel removal is required.

NOTE: ENSURE THAT PLATENS ARE STRAPPED DOWN SECURELY THROUGH STEP 3 TO PREVENT PLATENS FROM RAISING. SEVERE DAMAGE MAY OCCUR.

CABLE TIES

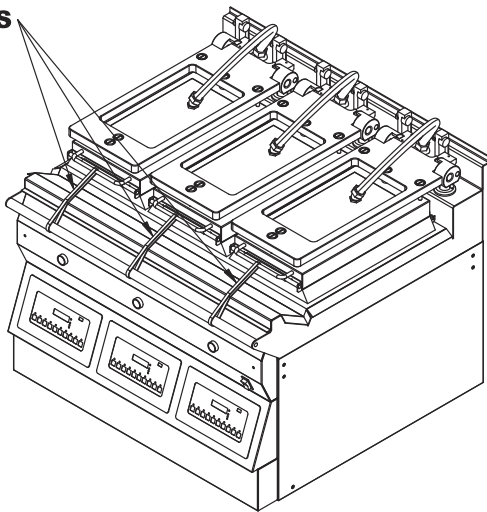

2. Tip unit over on its back. Install caster channels and casters as shown.

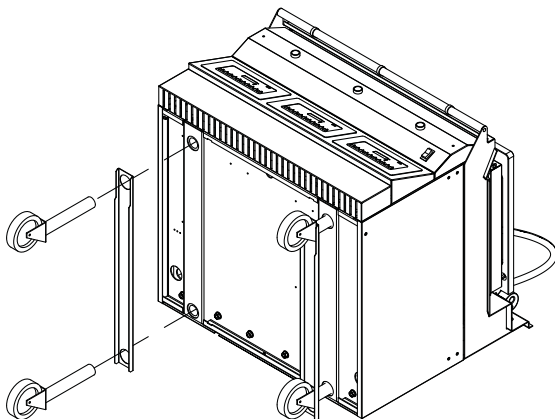

3. Carefully rotate grill back on its casters. Now you may cut and remove the platen securing straps.
4. Remove back body side and Install power cords per your country / area's specifications.

WARNING: Electrical appliances must be electrically grounded in accordance with local codes or in the absence of local codes, with national electric code ANSI/NFPA - latest version.

All electric connections must be made by a qualified, properly equipped technician.

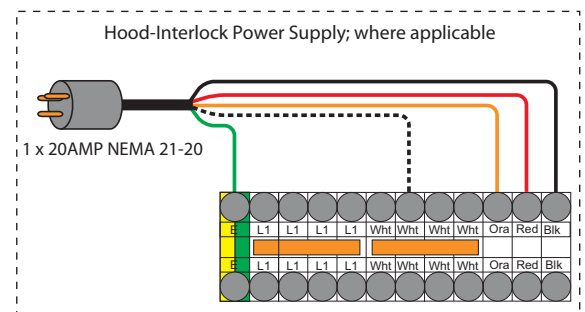
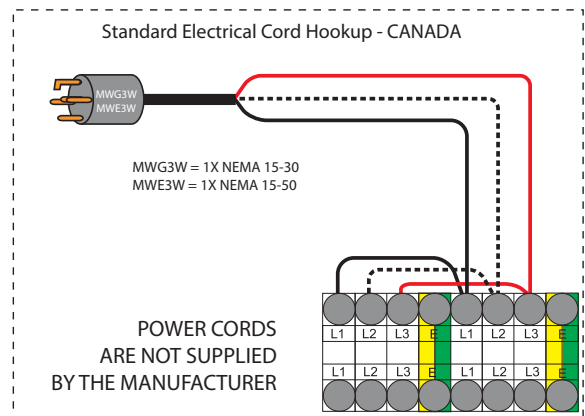
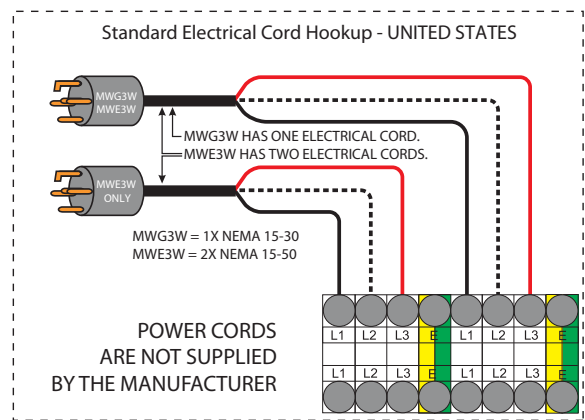

INSTALLATION & STARTUP *(continued)*

- GAS GRILL ONLY**, (for electric grills, skip to step 6 on the next page): Install the included quick-disconnect gas hose to the inlet fitting on the underside of the grill by threading a 3/4" NPT nipple into the elbow, then install the brass male quick-connect coupler included with the hose.

Connect the hose and ensure the sleeve snaps fully forward against the retaining ring.

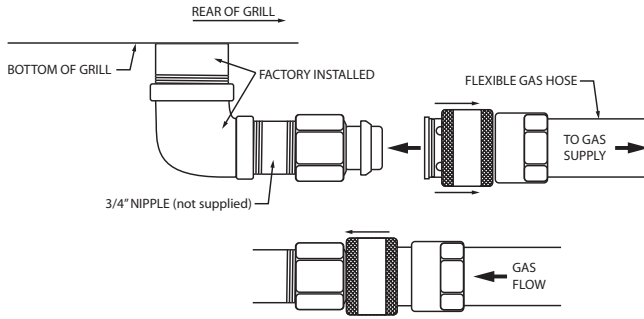

With the manual shut-off valve closed, install the other end of the hose to the gas supply.

- Install grease bucket rails as shown below:

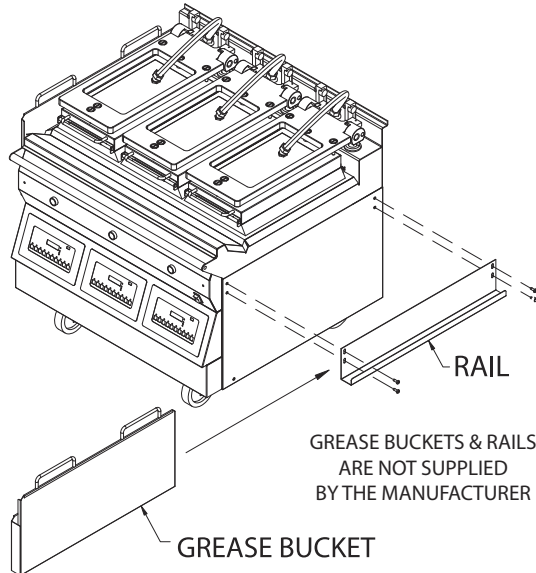

- Install flue box to back of grill.

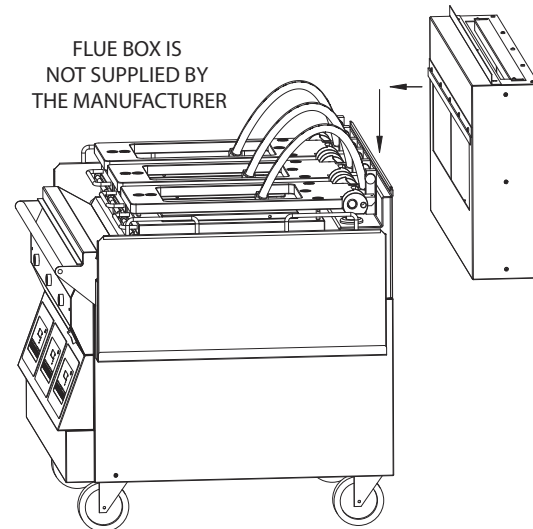

- Roll grill under hood. Grill must be level front to back, side to side and diagonally. Adjust casters accordingly to obtain final level.

INSTALLATION & STARTUP *(continued)*

Start Up Procedure

This Garland 3-platen grill comes with a Factory Start up at no additional charge. A start up is required to take place **BEFORE** the unit is put into operation. It is the end-user responsibility to schedule the start up with their local Factory Authorized Service Agent, or notify Garland Commercial Industries at 1-800-446-8367 should you need assistance scheduling.

A factory start up is a comprehensive grill check in which a factory certified technician will document all final settings programmed in the controller once various other performance checks are complete. The estimated time to complete a start up is approximately 2.5 – 3.5 hours. Please keep in mind this estimated time when scheduling the start up. After hours or overtime is not covered under warranty and will be billed at a charge which is the difference between the Garland Reimbursement rate and the Factory Authorized Service Centers overtime charges.

A factory startup is necessary to start the warranty period. The Authorized Service Center is required to complete the paperwork during the start up process, and send it to Garland Commercial Industries for reimbursement. At the time of receipt, Garland will start the warranty period which will conclude at the end of 2 years. You may contact your Kitchen Equipment Supplier or dial 1-866-735-1955 for more details regarding an optional 3rd year extended warranty plan.

Hood Type & Platen Height

With the platens in the raised position, measure the height from the front edge of the platen to the grill surface. Determine which type of hood the store has and check for hood type/platen height compatibility according to the table below:

HOOD TYPE	CORRECT PLATEN HEIGHT
Universal	18 ½" (470mm)
92 Series	17" (432mm)
GSC	18 ½" (470mm)

If the platen height is incompatible with the hood type, platen height must be adjusted by an authorized service agent.

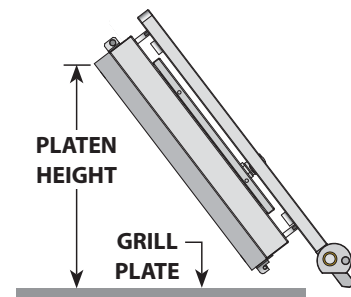

INSTALLATION & STARTUP *(continued)*

Document the Startup

All aspects of the Startup procedure must be documented using the Garland-issued form, part #4521780.

GARLAND CLAMSHELL GRILL START – UP FORM

ELECTRIC OR COMBINATION GAS / ELECTRIC

(FOR USE IN MODEL MWE3/MWG3 Series grills ONLY)

McDonald's _____ Certification ID # _____ Store # _____ Start-up Date _____
Located on Certification Sticker MM / DD / YY
 Address _____ City _____ Model # _____
 State / Province _____ Zip Code _____ Serial # _____

United States Canada International (List Country) _____ Telephone # _____

Grill Size & Type	Gas Type	Electric / 3-phase	Record Amps Per Line Each Contactor		
			Left	Center	Right
<input type="checkbox"/> 36" <input type="checkbox"/> 24"	Platen Locations: <input type="checkbox"/> L <input type="checkbox"/> C <input type="checkbox"/> R <input type="checkbox"/> Propane Gas <input type="checkbox"/> Natural Gas <input type="checkbox"/> Butane Gas <input type="checkbox"/> Other (please specify)	Actual Input _____ <input type="checkbox"/> 208 VAC <input type="checkbox"/> 380 VAC <input type="checkbox"/> 220 VAC <input type="checkbox"/> 400 VAC <input type="checkbox"/> 230 VAC <input type="checkbox"/> 415 VAC <input type="checkbox"/> 240 VAC	Line 1		
			Line 2		
			Line 3		

INSPECTION / OPERATIONAL CHECK

1. Ensure grill is installed in the proper type of gas exhaust hood with the proper air draw.	<input type="checkbox"/> OK
2. Ensure flu restrictors are fully opened or removed. Flue Box Supplied by KES Flu Restrictors located inside exhaust hood	<input type="checkbox"/> OK
3. Ensure bottom plate is leveled side to side / front to back / diagonally, in location, under hood. Adjust casters to attain level.	<input type="checkbox"/> OK
4. REMOVE GRILL FROM UNDER THE HOOD. Turn Power Switch ON, controller displays are active, Controller displays "OFF". Platen raises automatically?	<input type="checkbox"/> OK
5. Lower and raise Upper Platen and insure movement is smooth and continuous. Grease shafts accordingly with a FOOD GRADE LUBRICANT.	<input type="checkbox"/> OK
6. If upper platen elevation requires lowered to allow for clearance of hood, lower upper limit switch. Refer to Operations & Installation manual for platen heights.	<input type="checkbox"/> OK <input type="checkbox"/> Adjusted
7. Press the POWER ON button. Controller displays "PREHEAT - AM", platen lowers and alternately flashes "TOO COOL". Heat indicator lights are AMBER?	<input type="checkbox"/> OK
8. Press the AM / PM key. This will allow the unit to heat to: Platen-425°F(217°C), Grill-350°F(177°C).	L <input type="checkbox"/> OK / C <input type="checkbox"/> OK / R <input type="checkbox"/> OK
9. Verify that the grill has reached set temperature and begins timing down (15:00) soak.	L <input type="checkbox"/> OK / C <input type="checkbox"/> OK / R <input type="checkbox"/> OK
10. Close valve handle and verify the unit tries to ignite four (4) times. Unit locked out to Ignition Failure?	L <input type="checkbox"/> OK / C <input type="checkbox"/> OK / R <input type="checkbox"/> OK
11. GAS PRESSURE CHECKS (if applicable): Rated Incoming Pressure Natural Gas 6 – 14 Inches W.C. Actual Incoming _____ Propane / Butane Gas 11 – 14 Inches W.C. Actual Incoming _____ Rated Burner Pressure Natural Gas 3.5 Inches W.C. Actual Left _____ Center _____ Right _____ Propane / Butane Gas 10 Inches W.C. Actual Left _____ Center _____ Right _____	
12. Check micro amp reading to ensure operating micro amps ARE NO LESS THAN .8. Micro Amp reading should be between .8 – 1.6.	
13. Upper platen auto calibrates at temperatures: Platen-425°F(217°C), Grill-350°F(177°C)	<input type="checkbox"/> OK
14. Upon Completion of auto calibration, platen raised automatically, and display reads "READY" If upon completion of auto calibration process, upper platen does not raise, indicate message on controller. Check platen level and adjust reed switches. Cycle power and retry.	OK - <input type="checkbox"/> L / <input type="checkbox"/> C / <input type="checkbox"/> R Check Platen Level - <input type="checkbox"/> L / <input type="checkbox"/> C / <input type="checkbox"/> R Check Reed Switch - <input type="checkbox"/> L / <input type="checkbox"/> C / <input type="checkbox"/> R
15. Controller displays "Grill Ready In:" and counts down from 15:00.	L <input type="checkbox"/> OK / C <input type="checkbox"/> OK / R <input type="checkbox"/> OK
16. Select menu item "10:1 – CLAM". Verify set temperature is reached and LED lights turn GREEN.	L <input type="checkbox"/> OK / C <input type="checkbox"/> OK / R <input type="checkbox"/> OK
17. Initiate cook cycle by pushing the GREEN PUSHBUTTON. Platen lowers, and timing cycle begins.	L <input type="checkbox"/> OK / C <input type="checkbox"/> OK / R <input type="checkbox"/> OK
18. Ensure the stores pyrometer is accurate and calibrated using the ice bath method.	<input type="checkbox"/> OK
19. Perform PROBE CALIBRATION.	L <input type="checkbox"/> OK / C <input type="checkbox"/> OK / R <input type="checkbox"/> OK
20. Perform Platen Zeroing procedure.	L <input type="checkbox"/> OK / C <input type="checkbox"/> OK / R <input type="checkbox"/> OK
21. Perform REED Switch Calibration.	L <input type="checkbox"/> OK / C <input type="checkbox"/> OK / R <input type="checkbox"/> OK
22. Enter CALIBRATION menu and perform a "FORCE AUTO CAL"	L <input type="checkbox"/> OK / C <input type="checkbox"/> OK / R <input type="checkbox"/> OK
23. Assist or obtain assistance with store personnel for Beef Integrity Testing , testing product 10:1 and 4:1 until desired internal product temperatures are met.	L <input type="checkbox"/> OK / C <input type="checkbox"/> OK / R <input type="checkbox"/> OK
24. Record cook times, gap settings, and any gap calibrations used to obtain beef integrity.	L <input type="checkbox"/> OK / C <input type="checkbox"/> OK / R <input type="checkbox"/> OK
25. Record Calibration numbers below:	

Product Cook Times			Calibration numbers (from CALIBRATION MENU)				
	Product	Cook Time		Back Reed Cal	Front Reed Cal	Back Zero Cal	Front Zero Cal
LEFT	10:1						
	4:1						
CTR	10:1						
	4:1						
RIGHT	10:1						
	4:1						

Problems / Special Circumstances / Damage: _____

Submitted by:	Accepted by:
Name: _____	Name: _____
Service Agency: _____	Are you satisfied with the start-up procedure that has been performed? Please indicate any comments
Sub Agent: (If Applicable) _____	_____
Are you a factory certified technician? YES / NO	_____
Date of Certification / /	_____

White Copy – Factory Yellow Copy – Service Agency Pick Copy – Customer

Rev 2 P/N 4521780 W(070208)

INSTALLATION OF WRAP AROUND RELEASE MATERIAL MOUNTING BRACKETS

CAUTION: UPPER PLATEN IS EXTREMELY HOT. WARNING: ISOLATE POWER SOURCE TO PREVENT ELECTRICAL SHOCK.

1. Ensure Electrical Power is unplugged before proceeding to next step.
2. Loosen 2 screws from each side of the platen lid.
3. Position side bracket assemblies over screws and insert into place.

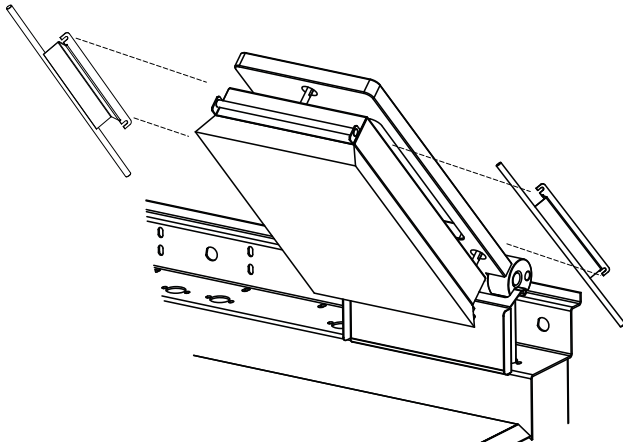

4. Retighten four (4) screws on the platen lid.

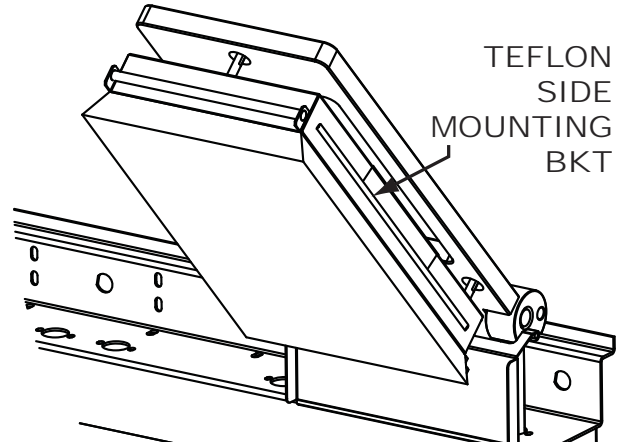

Part Number	Description	Qty Per Full Size (3P) Grill
4526334	Teflon Bracket, Side (3 Platen Grill)	6 Grill, 2 Platen
4527294	Teflon Clip w/ Flange	15 Grill, 5 Platen

INSTALLATION OF SPLASH SHIELD

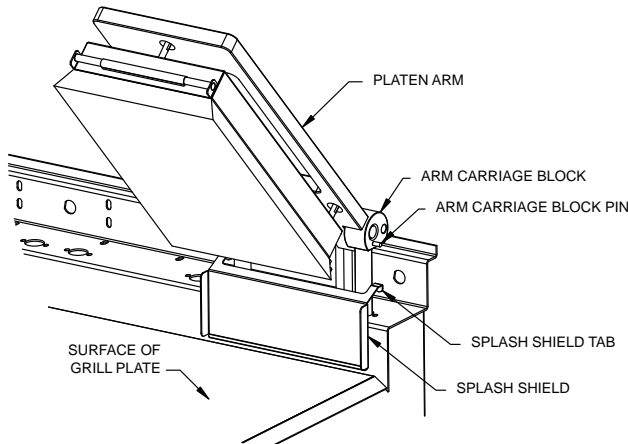

NOTE: SOME COMPONENTS OMITTED FOR CLARITY

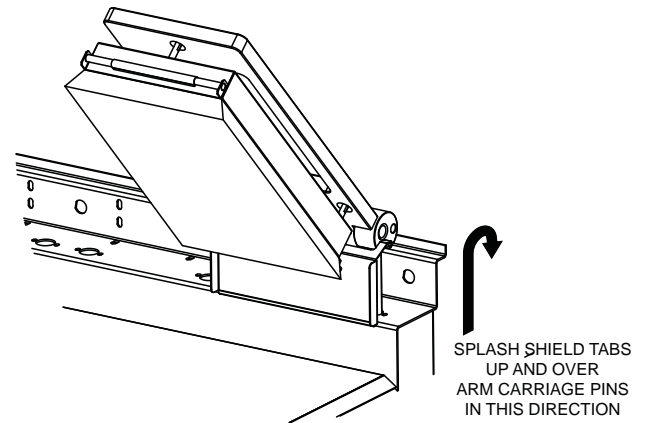

NOTE: SOME COMPONENTS OMITTED FOR CLARITY

INSTALLATION OF RELEASE MATERIAL

- Slide release material rod through hemmed end of the release material sheet.

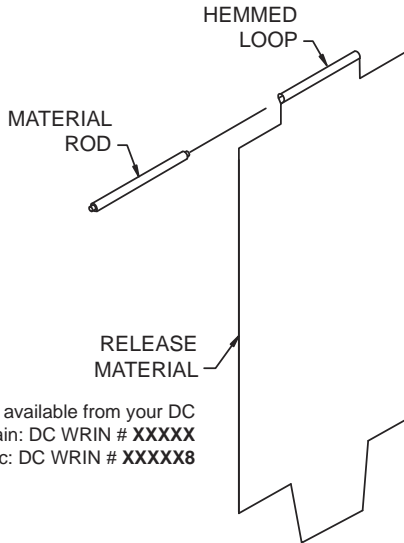

"Teflon Sheet" available from your DC
Saint Gobain: DC WRIN # XXXXX
Taconic: DC WRIN # XXXXX8

- Hook release material rod on brackets located at the rear of the upper platen.

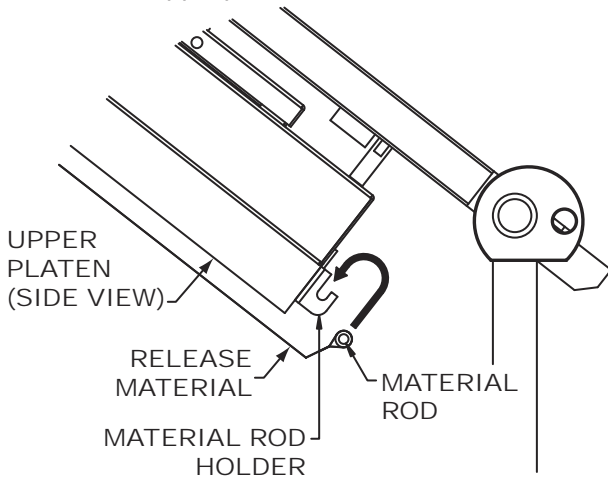

- Holding the bottom of the release material sheet in place, gently pull the sheet toward the front of the platen.

NOTE: Make sure release material fits smoothly over upper platen.

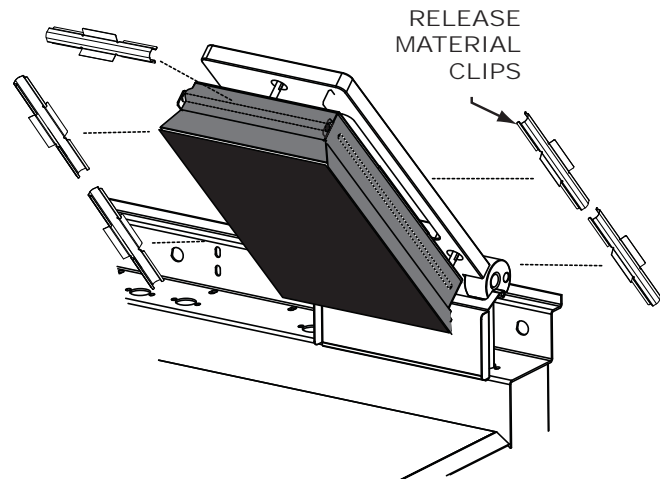
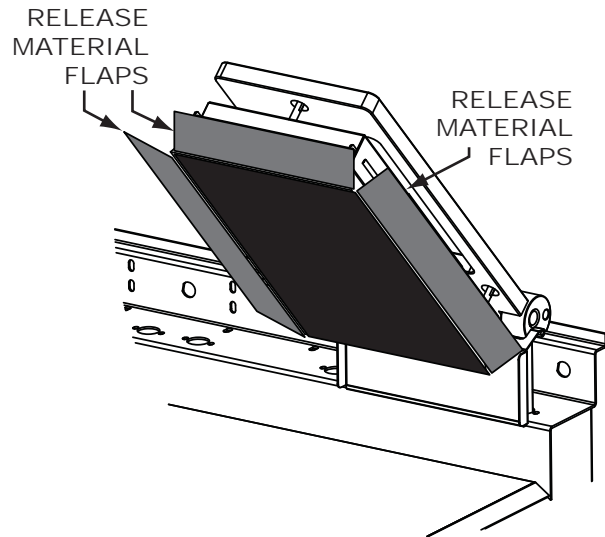

- Place five (5) locking clips over release material sheet and press into place over release material bar (2 ea sides, 1 front center).

NOTE: Failure to install the correct number of clips on the upper platen will cause the release material to be loose, and wear quickly. Ensure the correct placement of ALL clips to prevent premature wear and/or poor product quality.

- Check alignment and rightness of release material against upper platen.

GRILL ACCESSORIES

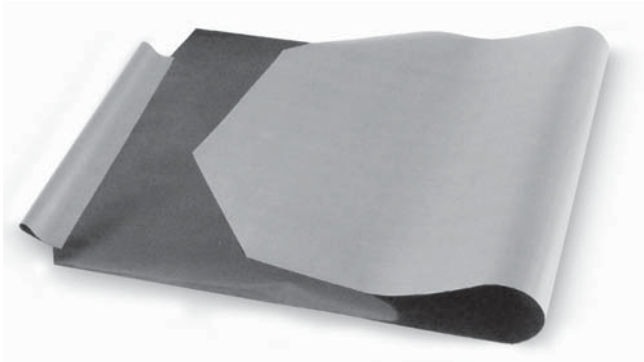

Teflon Sheet
Item 4521792 \$45.00 US (pack of 3)



Splash Shield
Item 4523492 \$30.00 US (each)



Teflon Sheet Rod
Item 4521355 \$18.72 US (each)



Splash Shield, Japan Type
Item 4525436 \$45.30 US (each)

Teflon Sheet Retaining Clip
Item 4527294 \$6.50 US (each)



Quick-Disconnect Gas Hose
Item 1591506 \$400.00 US (each)



Vapor Shield Complete (2 shown)
Item CK4525215 \$153.64 US (each)



OPERATING INSTRUCTIONS

GARLAND GAS & ELECTRIC CLAMSHELL GRILLS WITH PRODUCT RECOGNITION



DESCRIPTION OF GRILL CONTROL

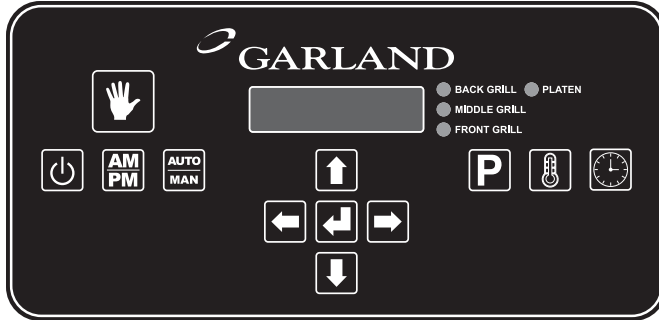

	Power Button – PRESSING and HOLDING the Power button for 2 seconds will either turn the controller on or off.
	AM/PM Button – In normal operating mode, toggles between the AM menu library and the PM menu library.
	AUTO/MAN Button – In normal operating mode, toggles between Automatic Product Recognition and Manual Cooking.
	Up Arrow Button – In any mode, increases the value of the flashing cursor character in the display
	Down Arrow Button – In any mode, decreases the value of the flashing cursor character in the display

	Right Arrow Button – In any mode, scrolls forward through a list
	Left Arrow Button – In any mode, scrolls backward through a list
	Enter Button – In the normal operating mode, this button is not active. In the Programming Mode, used to lock in the values shown on the display.
	Program Button – In the normal operating mode, pressing and holding the PROGRAM button for 3 seconds enters the Programming Mode.
	Temp Button – In the normal operating mode, displays the set temperature and the actual temperature.
	Speed Key – In the normal operating mode, used to change cook time. Also used to enter Probe Calibration Mode.
	Standby Button – In the normal operating mode, places the grill in Standby Mode.

POSSIBLE ERROR MESSAGES

GRILL PROBE ERROR – A grill temperature probe circuit error for temperature zone (Front, Middle, or Back) has occurred.

PLATEN PROBE ERROR – An upper platen temperature probe circuit error has occurred.

HEATER ERROR – Occurs when the controller does not detect a temperature rise in six (6) minutes.

HIGH TEMP – Occurs when the controller senses a temperature of 465° F (241° C).

CHECK REED SWITCH / USE FLAT COOK – One or more of the Reed Switches are out of adjustment. User will only be able to cook FLAT menu items.

ERROR COMMS - A communications error has occurred between the Motor Speed Control and the Main Control.

PLATEN NOT LEVEL – Occurs if the calibration difference between the front and rear is greater than maximum allowance. Product Recognition (Auto) and manual cooking is DISABLED. Flat Menu cooking is ONLY allowed.

CHECK PLATEN LEVEL – Occurs if the calibration difference between the front and rear is greater than the minimum allowance, but less than the maximum allowance. Product Recognition (Auto) is DISABLED. Perform If **CHECK PLATEN LEVEL** is displayed, perform the following steps:

1. PRESS AND HOLD the and buttons for 3 seconds. The control will display AUTO GAP FORCE.
2. PRESS the button. “NO” will flash on the display. PRESS the button to change it to “YES.”
3. PRESS the button. The platen will immediately lower and reset its internal measurements. Upon completion, the platen will rise. If the error message does not return continue operating normally. If the error message persists, call your local authorized service agent.

OPERATING PROCEDURES

General Overview:

The PRC grill control will allow for 2 functions, both described in detail in the following sections

The **“Normal Operating Mode”**, also known as the Cook Mode is the mode used during normal cooking. In the normal operating mode, the operator can start a cook cycle, cancel a cook cycle, view actual temperatures, scroll to another menu item, and enter the Programming Mode.

The **“Programming Mode”** is the mode in which the operator can program the controller’s various settings. To enter the programming mode, PRESS and HOLD 

There are currently 3 methods of cooking that can be utilized with the MWE3 Garland clamshell:

Standard Cooking – This is the cook method that utilizes a single gap setting for each menu item. The timer will count down according to the selected menu item.



Multi Stage Cooking – This method of cooking utilizes 2 different gap settings during the cook cycle. The timer will count down according to the selected menu item.

Product Recognition – The product recognition method of cooking uses the magnetic switches mounted on the upper platen arm assembly to determine the product being cooked. Using the PR feature, the operator simply selects the  button on the controller. This will allow the controller to know what product group to select from. When a cook cycle is initiated, the platen will come down and recognize the product being cooked. The cook timer will count down according to the time set for the recognized item. For more information on product Recognition, see the next section; “Product Recognition.”

To turn the grill on:

The Main Power Switch – Controls power to the grill and must be turned ON to start operation. The controller displays will be active. Upon successful power up checks, the controllers will displays “OFF”.



AM Operation – Teflon Sheets MUST be ON at this time and the grill surface should be free and clear of carbon.

Once the PRC displays “OFF” press . The PRC will go to PREHEAT mode and default to AM preheat temperatures. To preheat to PM temperatures, press and hold .

AM PREHEAT	PM PREHEAT
375°F (190°C) Upper Platen 275°F (135°C) Grill	425°F (218°C) Upper Platen 350°F (177°C) Grill

Upon reaching the AM or PM set temperature (whichever is selected), the grill will stabilize in temperature for fifteen (15) minutes. Once this time has elapsed, the grill will autocalibrate. Upon completion of autocalibration, the upper platens will raise to there normal position, and the PRC will display “READY”.

To Select a Menu item:

Scroll forward through the list of available menu items by pressing  repeatedly. Scroll backward through the list of available menu items by pressing  repeatedly.

Menu Item Library

The menu item library is loaded in the computer based upon the setting programmed in [CONFIGURE]->[GRILL REGION]. Each menu item consists of a function called [DISPLAY ACTIVE]. The settings in this function (AM, PM, AM/PM, No) determine what menu items are displayed when the  button is pressed.

Menu Item #	Menu Item	Display Active – Default
1	10:1 - CLAM	PM
2	4:1 - CLAM	PM
3	STRIP BACON - CLAM	AM/PM
4	SAUSAGE CLAM FZN	AM
5	MCRIB - CLAM	NO
6	STEAK - CLAM	AM/PM
7	GRILLED CHICKEN - FLAT	PM
8	FOLDED EGGS FLAT	AM
9	ROUND EGGS - FLAT	AM
10	CHICKEN FLAT BRD - FLAT	NO
11	10:1 FLAT	NO
12	4:1 - FLAT	NO
13	MCRIB - FLAT	NO
14	SAUSAGE FLAT FZN	NO
15	HOTCAKES - FLAT	NO
16	OPT MENU 1 - CLAM	NO
17	OPT MENU 2 - CLAM	NO
18	ANGUS 3:1 CLAM	NO
19	MUSHROOMS CLAM	NO
20	OPT MENU 5 - CLAM	NO
21	OPT MENU 6 - CLAM	NO
22	OPT MENU 7 - CLAM	NO
23	OPT MENU 1 - FLAT	NO
24	OPT MENU 2 - FLAT	NO
25	OPT MENU 3 - FLAT	NO
26	OPT MENU 4 - FLAT	NO

OPERATING PROCEDURES (continued)

Indicator Lights

The LED lights on the main control indicate the temperature status of each zone.

Electric grills have (4) zones per section , TOP, (platen), BACK GRILL, MIDDLE GRILL, and FRONT GRILL.

Gas grills have (2) zones per section , TOP, (platen), and GRILL.

RED – The zone(s) is “TOO HOT” (more than 79°F/43°C over set temperature) OR a heat zone failure has occurred.

AMBER – The zone(s) is calling for heat.

GREEN – The zone(s) is at or above set temperature, but below 79°F/43°C over set temperature.

Standby Mode



To enter the standby mode:

1. Press the  button. The upper platen will lower, and the grill will maintain a set temperature of Upper platen - 425° F (218°C), Grill Surface - 350° F (177°C).

To Exit the Standby Mode:





1. Press the  GREEN PUSHBUTTON. The upper platen will raise.

To display the current temperatures:

1. Press the  button and repeat for each zone to be displayed:
 1st key press – Front Set Point
 2nd key press – Front Actual
 3rd key press – Mid Set Point
 4th key press – Mid Actual
 5th key press – Back Set Point
 6th key press – Back Actual
 7th key press – Platen Set Point
 8th key press – Platen Actual
2. Pressing and holding the  button for five (5) seconds will display all of the current temperatures at once.

T### F###	T### GAS
M### B###	GAS B###
ELECTRIC DISPLAY	GAS DISPLAY

BREAKFAST IN MANUAL MODE





1. Select AM mode. Press and hold the  button.
2. Select Manual mode. Press and hold the the  button.
3. Select a product from the AM product library using the  or  arrow buttons.
4. Following McDonalds procedures for the item selected,

load product on the grill.







5. Press the  GREEN pushbutton to initiate a cook cycle.
6. Alarm will sound when the cook cycle is complete.
7. Remove product and clean grill to prepare for the next cook cycle.

LUNCH IN MANUAL MODE



Note: Switching from Breakfast to Lunch menu items will take approximately 10 minutes to heat to the appropriate temperatures.

1. Select PM mode. Press and hold the  button.
2. Select Manual mode. Press and hold the  button.
3. Select a product from the PM product library using the  or  arrow buttons.
4. Following the below lay pattern, load product on the grill.
5. Press the  GREEN pushbutton to initiate a cook cycle.
6. Alarm will sound when the cook cycle is complete
7. Remove product and clean grill to prepare for next cook cycle.

To Change The Cook Time for a Menu Item

1. Select AM or PM mode. Press and hold the  button.
2. Select Manual mode. Press and hold the  button.
3. Select a product using the  or  arrow buttons.
4. PRESS the  button to display the cook time.
5. Use the  and  buttons to change the cook time.
6. The control will automatically default back to the normal operating mode after 3 seconds.

BREAKFAST IN AUTO MODE

1. Select AM mode. Press and hold the  button.
2. Select Auto mode. Press and hold the  button. The control will display “AM / AUTOMATIC”
3. Following McDonalds procedures for the item selected, load product on the grill.
4. Press the  GREEN pushbutton to initiate a cook cycle.



OPERATING PROCEDURES *(continued)*

The platen will lower, and recognize the product that has been loaded on the grill.

5. Alarm will sound when the cook cycle is complete.
6. Remove product and clean grill to prepare for the next cook cycle.

LUNCH IN AUTO MODE



Note: Switching from Breakfast to Lunch menu items will take approximately 10 minutes to heat to the appropriate temperatures.

1. Select PM mode. Press and hold the  button.
2. Select Auto mode. Press and hold the  button. The control will display "PM / AUTOMATIC."
3. Following the lay patterns shown on the following page, load product on the grill.

4. Press the  GREEN pushbutton to initiate a cook cycle. The platen will lower, and recognize the product that has been loaded on the grill.
5. Alarm will sound when the cook cycle is complete
6. Remove product and clean grill to prepare for next cook cycle.

TRANSITION COOKING

Approximately 30 minutes before changing to the lunch menu, perform the following:

1. PRESS the  button (to display the upper platen temperature).
2. Press the  button.
3. The upper platen indicator will light (AMBER) and maintain the normal operating (set) temperature.

PRODUCT RECOGNITION





This Garland Clamshell grill is equipped with Product Recognition Controls (PRC). This new technology allows the user to simply start a cook cycle WITHOUT having to select a specific menu item. The PRC will recognize the product thickness by utilizing switches inside the upper platen and the magnets mounted on the platen arms. Once the PRC calculates the thickness of the product that's been loaded, it will look up product from the product range library (below), and automatically select that product.

MENU ITEM	MIN GAP	MAX GAP
Breakfast Library Recommended Ranges		
Strip Bacon	.010	.130
Sausage Clam	.210	.405
Steak Clam	.430	.480

MENU ITEM	MIN GAP	MAX GAP
Lunch Library Recommended Ranges		
10:1 Clam	.160	.345
4:1 Clam	.365	.560
Strip Bacon	.001	.130

While cooking in Automatic Mode, the platen will lower and rest on the top of the product. The platen arms will continue to move in a downward motion performing various calculations to measure the thickness of the product that has been placed. In the event "**Product Not Recognized**" or the wrong product is recognized, perform an Auto Forced Calibration. Performing an Auto Force Calibration will reset the platen to the grill surface.

TO PERFORM AUTO FORCED CALIBRATION

1. PRESS and HOLD the  and  buttons together. The control will display AUTO FORCE CAL - NO.
2. PRESS the  button. The "NO" will begin to flash.
3. PRESS the  button. The flashing "NO" will change to flashing "YES".
4. PRESS the  button. **The upper platen will immediately begin to lower and perform an auto calibration routine.**

PATTY PLACEMENT

This procedure for placement and removal of meat products on the clamshell grill should be followed as indicated below and as follows:

1. Each gray rectangle depicted below represents one cooking; the area beneath one upper platen.
2. Patties are generally placed two at a time from front to back of grill and right to left.
3. The **removal order** of the patties is shown in the diagrams **by the number shown** in the center of each patty.

NOTE: Patty placement procedures for International Markets may differ. Follow the recommendations of your local McDonald's authorities.

Maximum patty load per lane:

- 8 regular (10:1) patties
- 4 angus (3:1) patties (region and country applicable)
- 6 quarter-pound (4:1) patties
- 8 sausage patties
- 6 circular bacon

NOTE: Lay patties 2 at a time, from front to back:

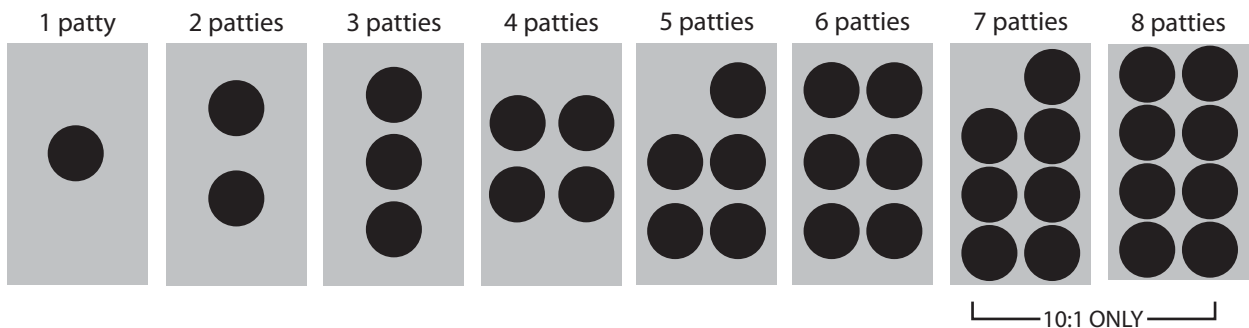

NOTE: Remove the patties in the number ordered shown below:

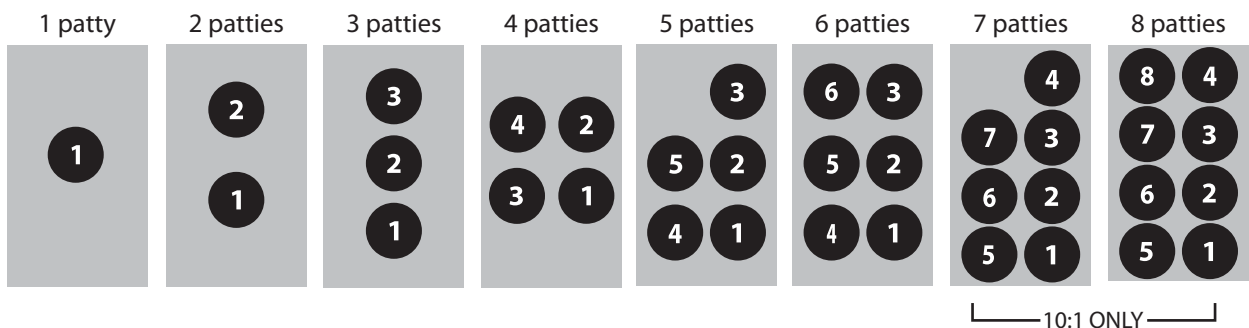

PROGRAM LOGIC

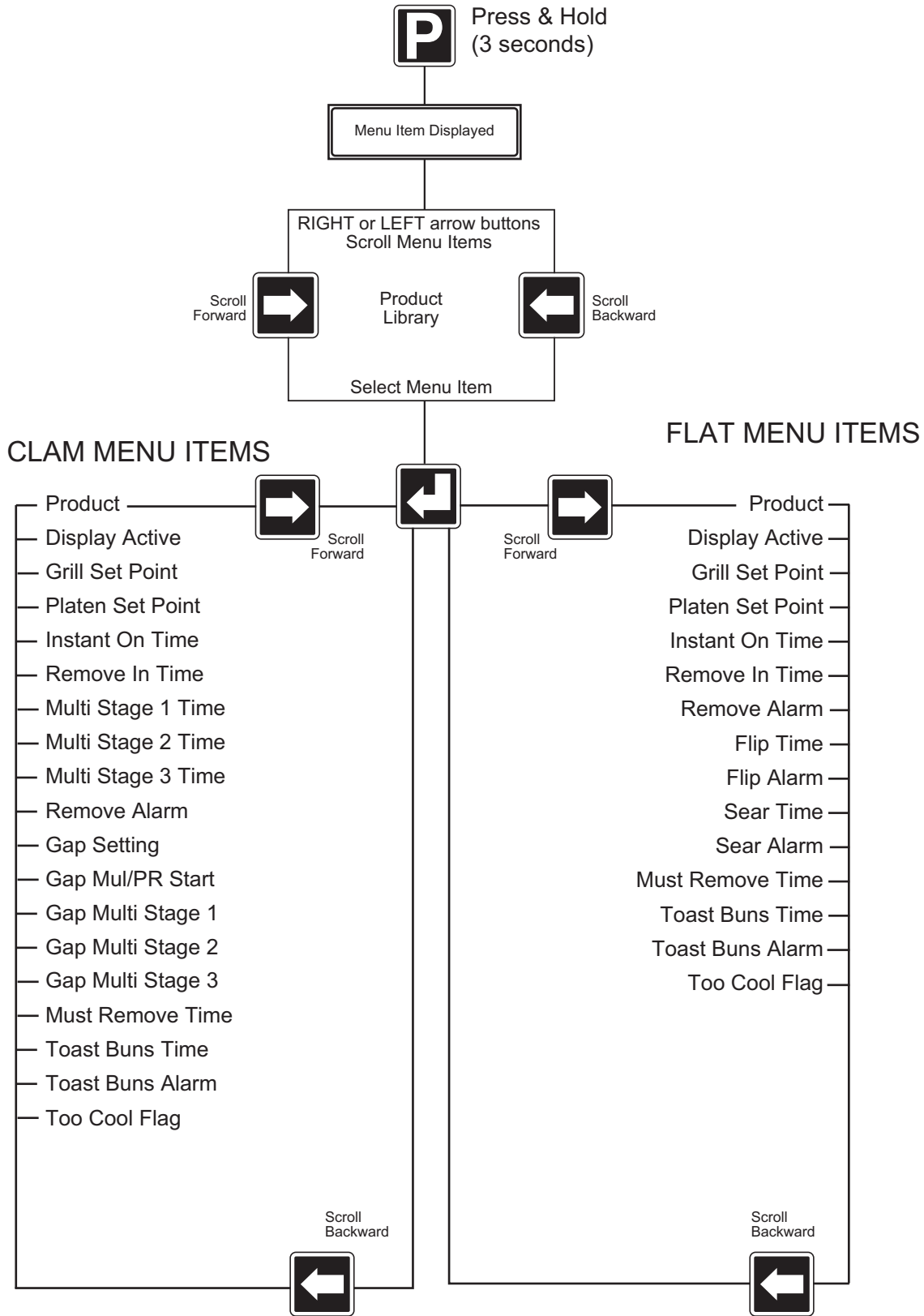











CONTROL PROGRAMMING

Programming Modes; System Setup







To Change the Temperature Display Units (Fahrenheit / Celcius)





The temperature display units (F or C) will change the way a temperature is displayed on the controller (F – Fahrenheit, C – Celcius)

1. With the controller display ON and either displaying the current menu item or displaying "OFF", PRESS and HOLD the  button for approximately 3 seconds. Controller will display previously selected menu item and its corresponding item number OR "Standby / Menu Item".
2. PRESS the  AND  arrow buttons TOGETHER. "CONFIGURE" will appear in the display.
3. PRESS the  arrow button. "Setup" will appear in the display
4. PRESS the  button. "Temperature Unit" will appear in the display.
5. PRESS the  button. The currently set temperature unit will flash.
6. PRESS the  OR  arrow buttons to change the flashing temperature unit.
7. PRESS the  button to save the new setting.
8. PRESS THE  2X to exit the program mode.

To Change the Time Display Units









Changing the Time Display Units will change the way timing cycles are displayed on the controller.

1. With the controller display ON and either displaying the current menu item or displaying "OFF", PRESS and HOLD the  button for approximately 3 seconds. Controller will display previously selected menu item and its corresponding item number OR "Standby / Menu Item".
2. PRESS the  AND  arrow buttons TOGETHER. "CONFIGURE" will appear in the display.
3. PRESS the  arrow button. "Setup" will appear in the display.
4. PRESS the  button. "Temperature Unit" will appear in the display.
5. PRESS the  1X. "Time Unit" will appear in the display.

6. PRESS the  button. The current time unit will flash.
7. PRESS the  OR  arrow buttons to change the flashing time unit.
For a complete listing of setup functions and their options, see page <?>.
8. PRESS the  button to save the new setting
9. PRESS THE  2X to exit the program mode.

To change the Key Chirp (Yes / No)

Changing the Key Chirp On or Off will either turn on or off the sound of the controller when a button is pressed.

1. With the controller display ON and either displaying the current menu item or displaying "OFF", PRESS and HOLD the  button for approximately 3 seconds. Controller will display previously selected menu item and its corresponding item number OR "Standby / Menu Item".
2. PRESS the  AND  arrow buttons TOGETHER. "CONFIGURE" will appear in the display.
3. PRESS the  arrow button. "Setup" will appear in the display
4. PRESS the  button. "Temperature Unit" will appear in the display.
5. PRESS the  repeatedly until "Key Chirp" appears in the display.
6. PRESS the  button. The currently set Key Chirp will flash.
7. PRESS the  OR  arrow buttons to change the flashing "YES" or "NO"
8. PRESS the  button to save the new setting.
9. PRESS THE 2X to exit the program mode.

To change the Audible

Changing the Audible Sound will change the way the controller sounds when a timing cycle has completed its countdown.

1. With the controller display ON and either displaying the current menu item or displaying "OFF", PRESS and HOLD the  button for approximately 3 seconds. Controller will display previously selected menu item and its corresponding item number OR "Standby / Menu Item".

CONTROL PROGRAMMING *(continued)*

2. PRESS the **↑** AND **↓** arrow buttons TOGETHER. "CONFIGURE" will appear in the display.
3. PRESS the **→** arrow button. "Setup" will appear in the display
4. PRESS the **→** button. "Temperature Unit" will appear in the display.
5. PRESS the **→** repeatedly until "Audible" appears in the display.
6. PRESS the **→** button. The currently set Audible will flash.
7. PRESS the **↑** OR **↓** arrow buttons to change the flashing audible options.
For a complete listing of setup functions and their options, see page <?>.
8. PRESS the **→** button to save the current setting.
9. PRESS THE **⏏** 2X to exit the program mode.

Programming Modes; Menu Items

To change the name of an existing menu item

1. Using the **→** or **←** button, select the menu item that requires a name change.
2. PRESS and HOLD the **⏏** button for approximately 3 seconds. Controller will display previously selected menu item and its corresponding item number.
3. PRESS and HOLD the **→** button.
4. To spell out the product name:
 - a. Use the **↑** or **↓** arrow buttons to scroll through the character library.
5. PRESS the **⏏** 2X to exit and return to normal operating mode.

Character Library:
 space ! " # \$ % & ' () * + , - . / 0 1 2 3 4 5 6 7 8 9 : ; < = > ? @ A B C D E F G H
 I J K L M N O P Q R S T U V W X Y Z [\] ^ _ ` a b c d e f g h i j k l m n o p q r
 s t u v w x y z

- b. PRESS **→** or **←** to scroll right or left.
- c. PRESS the **→** button to save the new menu item name.

To activate / deactivate a menu item in the Normal Operating mode library, or change its day-part (Defaults are listed on page 22 under 'Menu Item Library:')

1. PRESS and HOLD the **⏏** button for approximately 3 seconds. Controller will display previously selected menu item and its corresponding item number.
2. Using the **→** or **←** arrow buttons, select the menu item that requires activation / deactivation.
3. PRESS the **→** button. The controller will display "Product". The menu item will flash.
4. PRESS the **→** or **←** arrow buttons until "Display Active" is displayed on the controller.
5. PRESS the **→** button. The current setting will flash.
6. PRESS the **↑** or **↓** button to select a different setting.
7. PRESS the **→** button to save the new setting.
8. PRESS the **⏏** 2X to exit and return to normal operating mode.

To change the grill surface set point temperature











NOTE: Grill temperature set points are preset in the controller to the currently required standard. You should not change this set point to any temperature other than what is shown on page <?>.

1. Using the **→** or **←** arrow buttons, select the menu item that requires a temperature change.
2. PRESS and HOLD the **⏏** button for approximately 3 seconds. Controller will display previously selected menu item and its corresponding item number.
3. PRESS the **→** button. The controller will display "Product".
4. PRESS the **→** or **←** arrow buttons until "Grill SetPt" is displayed on the controller.
5. PRESS the **→** button. The current grill set temperature will begin to flash.
6. Using the **↑** or **↓** button, change the temperature set point to the new desired temperature.
7. PRESS the **→** button to save the new temperature set point.
8. PRESS the **⏏** 2X to exit and return to normal operating mode.











CONTROL PROGRAMMING *(continued)*

To change the grill upper platen set point temperature









NOTE: Grill temperature set points are preset in the controller to the currently required standard. You should not change this set point to any temperature other than what is shown on page <?>.

1. Using the  or  button, select the menu item that requires a temperature change.
2. PRESS and HOLD the  button for approximately 3 seconds. Controller will display previously selected menu item and its corresponding item number.
3. PRESS the  button. The controller will display "Product".
4. PRESS the  or  button until "Platen SetPt" is displayed on the controller.
5. PRESS the  button. The "PLATEN SET POINT" will begin to flash.
6. Using the  or  button, change the temperature set point to the new desired temperature.
7. PRESS the  button to save the new temperature.
8. PRESS the  2X to return to normal operating mode.











To Change the MUST REMOVE IN time

1. Using the  or  button, select the menu item that requires a cook time change.
2. PRESS and HOLD the  button for approximately 3 seconds. Controller will display previously selected menu item and its corresponding item number.
3. PRESS the  button. The controller will display "Product".
4. PRESS the  or  button until "Must Remove In" is displayed on the controller.
5. PRESS the  button. The seconds will begin to flash.
6. Using the  or  arrow buttons to change the Must Remove In time to the new desired time.
7. PRESS the  button to save the new time.
8. PRESS the  2X to return to normal operating mode.

To Change the Toast Buns time

1. Using the  or  button, select the menu item that requires a cook time change.
2. PRESS and HOLD the  button for approximately 3 seconds. Controller will display previously selected menu item and its corresponding item number.
3. PRESS the  button. The controller will display "Product".
4. PRESS the  or  button until "Toast Buns Time" is displayed on the controller.
5. PRESS the  button. The seconds will begin to flash.
6. Using the  or  button, change the Toast Buns Time to the new desired time.
7. PRESS the  button to save the new time.
8. PRESS the  2X to exit and return to normal operating mode.





























To Change the Toast Buns Alarm (Auto / Manual)

1. Using the  or  arrow buttons, select the menu item that requires a cook time change.
2. PRESS and HOLD the  button for approximately 3 seconds. Controller will display previously selected menu item and its corresponding item number.
3. PRESS the  button. The controller will display "Product".
4. PRESS the  or  button until "Toast Buns Alarm" is displayed on the controller.
5. PRESS the  button. The "AUTO" or "MANUAL" will begin to flash.
6. Using the  or  arrow buttons to change the "MANUAL" to "AUTO" or "AUTO" to "MANUAL".
7. PRESS the  button to save the new setting.
8. PRESS the  2X to exit and return to normal operating mode.









CONTROL PROGRAMMING *(continued)*

To Add NEW Menu Items







The following programming instructions serves as a GUIDE for programming the basic settings for CLAM menu items.

1. PRESS and HOLD the  button for approximately 3 seconds. Controller will display previously selected menu item and its corresponding item number.
2. PRESS the  or  button until "Opt menu # - CLAM" is displayed on the controller.
3. PRESS the  button. The controller will display "PRODUCT"
4. PRESS and HOLD the  button. The currently select menu item name will begin to flash.
5. To spell out the product name:
 - a. Use the  or  arrow buttons to scroll through the character library.
 - b. PRESS  or  to scroll right or left.
 - c. PRESS the  button to save the new menu item name.
6. PRESS the  button. "Display Active" will be displayed.
7. PRESS the  button. "NO" will begin to flash.
8. PRESS the  button. "NO" will change to "YES".
9. PRESS the  button to save the new setting.
10. PRESS the  button. "GRILL SETPT" will be displayed.
11. PRESS the  button. The temperature will begin to flash.
12. Using the  or  button, change the temperature set point to the new desired temperature.
13. PRESS the  button to save the new temperature set point.
14. PRESS the  button. "PLATSETPT" will be displayed.
15. PRESS the  button. The temperature will begin to flash.
16. Using the  or  button, change the temperature set point to the new desired temperature.
17. PRESS the  button to save the new temperature set point.
18. PRESS the  button until "GAP MULTI/PR START" appears in the display.
19. PRESS the  button. The gap setting will begin to flash.
20. Using the  and DOWN button, change the gap setting to the desired setting.
21. PRESS the  button to save the new gap setting.
22. PRESS the  button 2X to exit and return to the normal operating mode.

To Restore Factory Defaults for All Product Menu Items

1. With the controller display ON and either displaying the current menu item or displaying "OFF," PRESS and HOLD the  button for approximately 3 seconds. Controller will display previously selected menu item and its corresponding item number OR "Standby / Menu Item."
2. PRESS the  AND  arrow buttons TOGETHER. "CONFIGURE" will appear in the display.
3. PRESS the  arrow button. "Setup" will appear in the display
4. PRESS the  button. "Temperature Unit" will appear in the display.
5. PRESS the  button 6x. The controller will display "Reload Defaults – NO."
6. PRESS the  button. "NO" will begin to flash.
7. PRESS the  button. "NO" will change to "YES".
8. PRESS the  button. The system will Reload the MENU items to factory default settings.
9. Wait 15-20 seconds. The control then automatically returns to OFF mode.

To Restore Factory Defaults for All Functions

1. Ensure the main power is turned off by turning the main power switch to the OFF mode.
2. PRESS the  AND  arrow buttons TOGETHER, while cycling main power ON with the main power switch. The control will display "PASSWORD"
3. Within 3-5 seconds, press the following keys in this sequence:     
4. Upon successful completion, the controller will display FULL DEFAULTS
5. Wait 15-20 seconds. The control then automatically returns to OFF mode.

PROBE CALIBRATION

Monthly Calibration of Grill Temperature Zones

Tools: Digital Pyrometer with Surface Probe

Warning: PERSONAL INJURY FROM BURNS MAY RESULT WHEN COMING IN CONTACT WITH HOT COOKING SURFACES.

NOTE: Calibration of grills is done with release material sheets "OFF".

PLEASE FOLLOW THESE INSTRUCTIONS EXACTLY AS THEY APPEAR BELOW:

1. The upper platens and lower grill plate should be at operating temperatures to perform this calibration procedure. Press the or button to select a "CLAM" operation and allow the grill to reach the set temperature and stabilize, (approximately 30 minutes).
2. PRESS and HOLD the button for approximately 3 seconds, or until the controller will display: "PROBE CAL".
3. PRESS the button to display the first temperature zone to be calibrated. The first zone to be calibrated is "FRONT TEMP CAL". The zones are displayed in order of FRONT TEMP CAL, MIDDLE TEMP CAL, BACK TEMP CAL, TOP TEMP CAL.

MWE3W: The electric grill's thermocouple probes are located front to rear, as shown in the diagram to the right. Each upper platen has one thermocouple in the center.

MWG3W: The gas grill's thermocouple probes are located in the center of each lane, as shown in the diagram to the right. Each upper platen has one thermocouple in the center.

4. Select a heat zone display using the or buttons.
5. Allow at least 5 seconds for the pyrometer to respond and stabilize. Note the temperature on the pyrometer.
6. If the temperature on the grill control display does not match the temperature on the pyrometer, adjust the temperature on the grill control accordingly. The button will increase the displayed temperature in one, (1) degree increments. The button will decrease the displayed temperature in one, (1), degree Increments.

NOTE: During step 6, the control should be sounding a high-pitched tone. The temperature can only be adjusted if this tone is sounding. If the control is silent, the temperature will not change.

7. PRESS the button to lock the calibrated temperature into the controller.
8. Press the or button to select the next heat zone.
9. Move the pyrometer's surface probe to the newly selected heat zone and repeat steps 5, 6, and 7.
10. Repeat the procedure for each of the heat zones.
11. Continue to cycle through each heat zone repeating the sequence until all temperatures are within 1°.
12. Exit the program mode by pressing the button 2x. The controller will return to its previous state in the Normal Operating Mode.

THERMOCOUPLE LOCATIONS

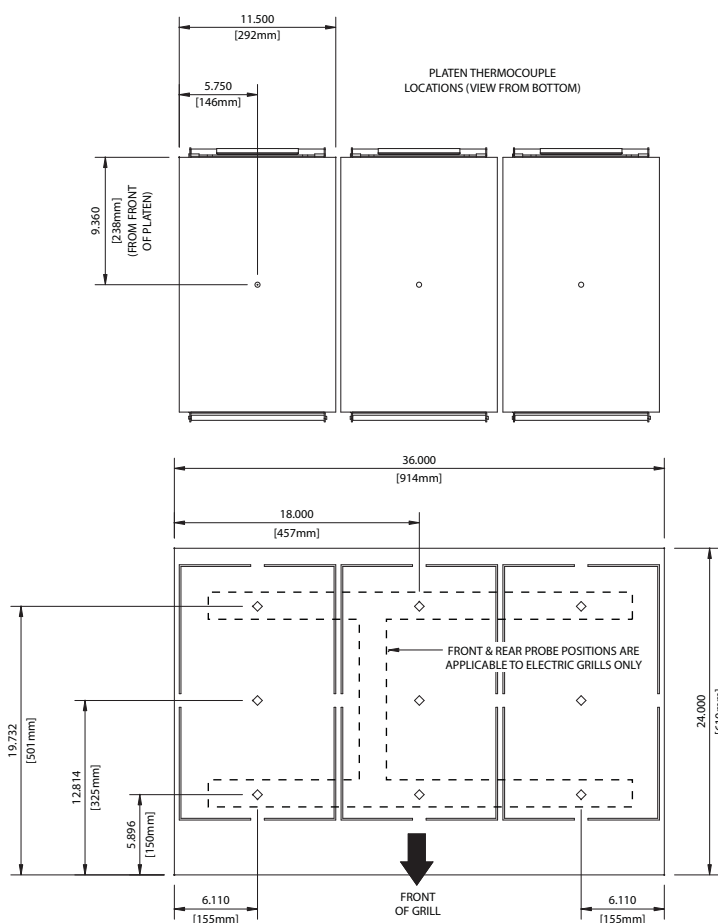

FACTORY DEFAULT SETTINGS (software version 202)

Clam Menu Items

Menu Item #	PRODUCT	DISPLAY ACTIVE	GRILL SET POINT	PLATEN SET POINT	INSTANT ON TIME	REMOVE IN TIME	MULTI STAGE TIME	REMOVE ALARM	GAP SETTING	GAP MULTI/PR START	GAP MULTI STAGE	MUST REMOVE IN TIME	TOAST BUNS IN TIME	TOAST BUNS ALARM	TOO COOL FLAG
1	10:1 - CLAM	PM	350°F (177°C)	425°F (217°C)	25	37	S1 5	AUTO	.255	.245	S1 .265	0	0	AUTO	NO
							S2 0				S2 0				
							S3 0				S3 0				
2	4:1 - CLAM	PM	350°F (177°C)	425°F (217°C)	30	107	S1 10	AUTO	.415	.400	S1 .425	0	0	AUTO	NO
							S2 ---				S2 ---				
							S3 ---				S3 ---				
3	STRIP BACON-CLAM	AM/PM	350°F (177°C)	425°F (217°C)	0	23	S1 ---	AUTO	.089	.089	S1 ---	0	0	AUTO	NO
							S2 ---				S2 ---				
							S3 ---				S3 ---				
4	SAUSAGE CLAM FZN	AM	350°F (177°C)	425°F (217°C)	0	82	S1 ---	AUTO	.350	.350	S1 ---	0	0	AUTO	NO
							S2 ---				S2 ---				
							S3 ---				S3 ---				
5	MCRIB - CLAM	NO	350°F (177°C)	425°F (217°C)	30	163	S1 ---	AUTO	.530	.530	S1 ---	0	0	AUTO	NO
							S2 ---				S2 ---				
							S3 ---				S3 ---				
6	STEAK-CLAM	AM/PM	350°F (177°C)	425°F (217°C)	0	104	S1 ---	AUTO	.415	.415	S1 ---	0	0	AUTO	YES
							S2 ---				S2 ---				
							S3 ---				S3 ---				
18	ANGUS 3:1 CLAM	PM	350°F (177°C)	425°F (217°C)	60	230	S1 ---	AUTO	.625	.625	S1 ---	0	0	AUTO	NO
							S2 ---				S2 ---				
							S3 ---				S3 ---				
19	MUSHROOM CALM	PM	350°F (177°C)	425°F (217°C)	60	104	S1 ---	AUTO	.415	.415	S1 ---	0	0	AUTO	YES
							S2 ---				S2 ---				
							S3 ---				S3 ---				
16 through 22	OPT MENU 1 through 7 CLAM	NO	0°F (0°C)	0°F (0°C)	0		S1 ---	AUTO	0	0	S1 ---	0	0	AUTO	
S2 ---	S2 ---														
S3 ---	S3 ---														

Flat Menu Items

	ITEM	DISPLAY ACTIVE	GRILL SET POINT	PLATEN SET POINT	INSTANT ON TIME	REMOVE IN TIME	FLIP TIME	SEAR TIME	ALARM - AUTO / MANUAL	SEAR ALARM - AUTO / MANUAL	FLIP ALARM - AUTO / MANUAL	MUST REMOVE IN TIME	TOAST BUNS TIME	TOAST BUNS ALARM - AUTO / MANUAL
7	GRILL CHICK-FLAT	PM	350°F (177°C)	425°F (217°C)	---	410	195	---	---	---	MANUAL	---	---	---
8	FOLDED EGGS-FLAT	AM	265 (130°C)	OFF	---	120	---	---	---	---	---	---	---	---
9	ROUND EGGS-FLAT	AM	265 (130°C)	OFF	---	150	---	---	---	---	---	---	---	---
10	CHICK F BRD-FLAT	NONE	350°F (177°C)	425°F (217°C)	---	100	---	---	---	---	---	---	---	---
11	10:1- FLAT	NONE	340 (171°C)	425°F (217°C)	---	125	75	20	---	MANUAL	AUTO	---	---	---
12	4:1-FLAT	NONE	365 (185°C)	425°F (217°C)	---	270	150	20	---	---	AUTO	---	---	---
13	McRIB-FLAT	NONE	365 (185°C)	425°F (217°C)	---	390	270	---	---	---	AUTO	---	---	---
15	HOTCAKES-FLAT	NONE	365 (185°C)	425°F (217°C)	---	140	90	---	---	---	AUTO	---	---	---
23 through 26	OPT MENU 1 through 4 - FLAT	NONE	---	---	---	---	---	---	---	---	---	---	---	---
	CLEAN MODE	AM/PM	325°F (163°C)	325°F (163°C)	---	---	---	---	---	---	---	---	---	---

TEMPERATURE CONVERSION

°C	°F	°C	°F	°C	°F	°C	°F	°C	°F
27	80	54	128	80	176	107	224	134	272
27	81	54	129	80	177	107	225	134	273
28	82	55	130	81	178	108	226	134	274
28	83	55	131	81	179	108	227	135	275
29	84	56	132	82	180	109	228	135	276
30	85	56	133	83	181	110	229	136	277
30	86	57	134	83	182	110	230	137	278
31	87	57	135	84	183	111	231	137	279
31	88	58	136	84	184	111	232	138	280
32	89	59	137	85	185	112	233	138	281
32	90	59	138	85	186	112	234	139	282
33	91	60	139	86	187	113	235	139	283
33	92	60	140	86	188	114	236	140	284
34	93	61	141	87	189	114	237	141	285
34	94	61	142	88	190	115	238	141	286
35	95	62	143	88	191	115	239	142	287
36	96	62	144	89	192	116	240	142	288
36	97	63	145	89	193	116	241	143	289
37	98	63	146	90	194	117	242	143	290
37	99	64	147	90	195	117	243	144	291
38	100	64	148	91	196	118	244	144	292
38	101	65	149	91	197	119	245	145	293
39	102	65	150	92	198	119	246	146	294
40	103	66	151	93	199	120	247	146	295
40	104	66	152	94	200	120	248	147	296
41	105	67	153	94	201	121	249	147	297
41	106	68	154	94	202	121	250	148	298
42	107	68	155	95	203	122	251	148	299
42	108	69	156	95	204	122	252	149	300
43	109	70	157	96	205	123	253	149	301
43	110	70	158	97	206	124	254	150	302
44	111	71	159	97	207	124	255	151	303
44	112	71	160	98	208	125	256	151	304
45	113	72	161	98	209	125	257	152	305
45	114	72	162	99	210	126	258	152	306
46	115	73	163	99	211	126	259	153	307
46	116	74	164	100	212	127	260	153	308
47	117	74	165	101	213	127	261	154	309
48	118	75	166	101	214	128	262	154	310
48	119	75	167	102	215	128	263	155	311
49	120	76	168	102	216	129	264	156	312
49	121	76	169	103	217	130	265	156	313
50	122	77	170	103	218	130	266	157	314
50	123	77	171	104	219	130	267	157	315
51	124	78	172	105	220	131	268	158	316
52	125	78	173	105	221	131	269	158	317
52	126	79	174	106	222	132	270	159	318
53	127	79	175	106	223	133	271	159	319

TEMPERATURE CONVERSION

°C	°F	°C	°F	°C	°F	°C	°F	°C	°F
160	320	187	368	213	416	240	464	267	512
161	321	187	369	214	417	241	465	267	513
161	322	188	370	214	418	241	466	268	514
162	323	188	371	215	419	242	467	268	515
162	324	189	372	216	420	242	468	269	516
163	325	189	373	216	421	243	469	269	517
163	326	190	374	217	422	243	470	270	518
164	327	191	375	217	423	244	471	271	519
164	328	191	376	218	424	244	472	271	520
165	329	192	377	218	425	245	473	272	521
166	330	192	378	219	426	246	474	272	522
166	331	193	379	219	427	246	475	273	523
167	332	193	380	220	428	247	476	273	524
167	333	194	381	221	429	247	477	274	525
168	334	194	382	221	430	248	478	274	526
168	335	195	383	222	431	248	479	275	527
169	336	196	384	222	432	249	480	276	528
169	337	196	385	223	433	249	481	276	529
170	338	197	386	223	434	250	482	277	530
171	339	197	387	224	435	241	483	277	531
171	340	198	388	224	436	241	484	278	532
172	341	198	389	225	437	252	485	278	533
172	342	199	390	226	438	252	486	279	534
173	343	199	391	226	439	253	487	279	535
173	344	200	392	227	440	253	488	280	536
174	345	201	393	227	441	254	489	281	537
174	346	201	394	228	442	254	490	281	538
175	347	202	395	228	443	255	491	282	539
176	348	202	396	229	444	256	492	282	540
176	349	203	397	229	445	256	493	283	541
177	350	203	398	230	446	257	494	283	542
177	351	204	399	231	447	257	495	284	543
178	352	204	400	231	448	258	496	284	544
178	353	205	401	232	449	258	497	285	545
179	354	206	402	232	450	259	498	285	546
179	355	206	403	233	451	259	499	286	547
180	356	207	404	233	452	260	500	287	548
181	357	207	405	234	453	261	501	287	549
181	358	208	406	234	454	261	502	288	550
182	359	208	407	235	455	262	503	288	551
182	360	209	408	236	456	262	504	289	552
183	361	209	409	236	457	263	505	290	553
183	362	210	410	237	458	263	506	290	554
184	363	211	411	237	459	264	507	291	555
184	364	211	412	238	460	264	508	291	556
185	365	212	413	238	461	265	509	292	557
186	366	212	414	239	462	266	510	292	558
186	367	213	415	239	463	266	511	293	559

Garland Installation & Operation Manual



Gas & Electric Clamshell Grills With Product Recognition

Garland Commercial Industries, LLC, 185 East South Street, Freeland, Pennsylvania 18224
Phone: +1 (570) 636-1000 • Fax: +1 (570) 636-9874
TOLL FREE Service Hotline: (800) 446-8367
<http://www.garland-group.com> • Email: qsrservice@garland-group.com



PART #4521777 (08/18/09)