

Operation Manual and Parts Directory

**Glas
tender®**

LC84

CONQUEST POST-MIX REMOTE SODA LINE CHILLER



Glastender, Inc. · 5400 North Michigan Road · Saginaw, MI · 48604-9780
800.748.0423 · 989.752.4275 · Fax 800.838.0888 / 989.752.4444 · www.glastender.com

INSPECTION AND LOCATION

Inspection Upon Arrival.....	1
Location of Remote Cooler.....	1
Removing the Top Cover.....	1

INSTALLATION

Electrical Hook-Up.....	2
Refrigeration Start-Up.....	2
Connection of Water Supply.....	2
Connection of “Product Out” Lines.....	2
Connection of “Product In” Lines.....	2
Connection of CO2 Cylinders.....	3
Start-Up of Dispensing System.....	3
Insulated Conduit.....	3

CLEANING AND MAINTENANCE

Water Level.....	4
Cleaning Hints.....	4
Water Bath Cleaning and Maintenance.....	4
Sanitizing Water Circuits.....	4
Sanitizing Syrup Circuits.....	4
Preventative Maintenance Schedule.....	5

TROUBLE SHOOTING PROCEDURES

Poor Carbonation.....	6
Bad Taste in Beverage.....	6
Noisy Carbonator Pump.....	6
Compressor Will Not Run.....	6
Compressor Runs But Stops.....	6
Compressor Runs But Will Not Cool.....	6
Carbonator Pump Motor Will Not Run.....	6
Carbonator Pump Motor Will Not Stop.....	6
Carbonator Pump Running In Wrong Direction.....	6
Circulating Pump Motor Will Not Run.....	6
Circulating Pump Running In Wrong Direction.....	6
Pump Leaking Water.....	6
Warm Beverage.....	6
Water Bath Freezing Completely.....	6
Noise In Water Bath.....	6

SPECIFICATIONS.....	7-8
---------------------	-----

TYPICAL INSTALLATION DIAGRAMS.....	9
------------------------------------	---

WIRING DIAGRAM.....	10
---------------------	----

LC84 COMPRESSOR AND RELATED PARTS.....	11 - 12
--	---------

WARRANTY.....	13
---------------	----

1. INSPECTION UPON ARRIVAL

- Immediately upon receipt of the unit, make a visual inspection of the carton to determine if there is evidence of damage. Following un-crating, make an inspection for signs of damage.
- If damage is found, notify the carrier immediately.
- The Transportation Company is liable for damage sustained during shipment but claims must be made with in 15 days.

2. LOCATION OF REMOTE COOLER

- Unit can be placed up to 150 ft. (45.7m.) from the dispensing station. The low profile design allows the unit to be located under counter.
- If unit is installed on the floor:
 - a) the cabinet must be sealed to the floor with an NSF listed silicon RTV applied around the entire periphery of the cabinet (see fig.1)
 - b) optional 6" legs must be installed to the cabinet bottom.
- If unit is installed on a countertop or shelf:
 - a) the cabinet must be sealed to the countertop or shelf with an NSF listed silicon RTV applied around the entire periphery of the cabinet. (see fig.1)
 - b) optional 4" legs must be installed to the cabinet bottom.
- Any location must have the ability to support the operating weight of the unit. (261 lbs./118 kg.)
- Avoid obstructions to the air intake and exhaust sections of the unit.
- Minimum clearance between the top, front, and back of and any obstruction is 12 in. (30.5cm.)
- Proper unrestricted airflow is essential.
- After the unit is in place, check to be sure it is level.

3. REMOVING THE FRONT COVER

- Remove the three-(3) screws in front of the unit, and two-(2) screws on top rear. (see fig.2)
- Lift cover up to disengage from rear of the unit, then pull forward.
- Do not remove the screws along the sides or back.

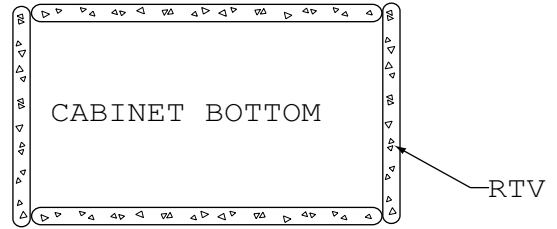

RTV TO FORM A TIGHT SEAL WHEN CABINET PLACED UP RIGHT

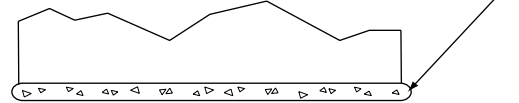

Fig. 1 Sealing Cabinet with RTV

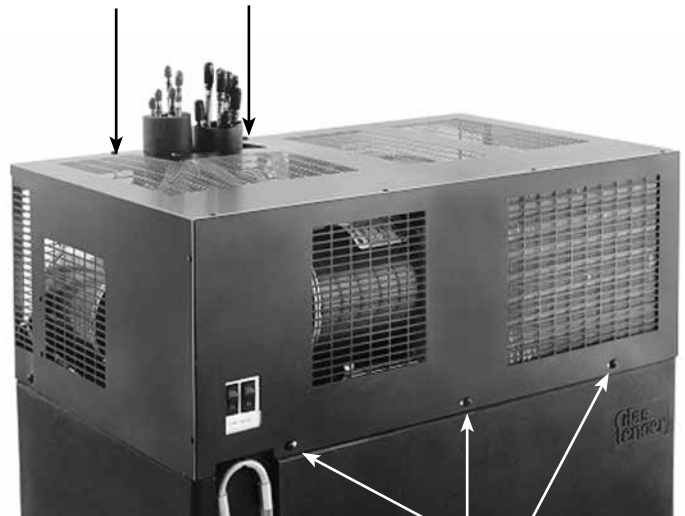

Fig. 2 Removal of Front Cover

1. ELECTRICAL HOOKUP

- Unit is supplied with a 20-amp line cord on the left rear of the unit.

NOTE: THIS UNIT REQUIRES 20 AMP CIRCUIT PROTECTION

- The main supply cord comes off the control box, located on the pump deck. The refrigeration power cord plugs into the back of the control box, also located on the pump deck.

2. REFRIGERATION START-UP

- Remove top cover. Locate the black plastic water bath fill-plug and remove it. (see fig.3)
- Fill the unit with clean water until water begins to come out of the overflow tube.
- Plug in main power cord and the condenser fan and compressor should start. (see fig. 3) If not, refer to “TROUBLESHOOTING PROCEDURES”.

NOTE: A small amount of water will flow out of the overflow tube until the ice is fully formed.

3. CONNECTION OF WATER SUPPLY

- Glastender, Inc. recommends that a 1/2” water line with shut-off valve be installed within 10-ft. (3 M.) of the unit. Incoming water pressure is not to be less than 20 P.S.I.

NOTE: If water pressure exceeds 60 P.S.I. or severely fluctuates, a water pressure regulator is required ahead of the brass pump to avoid flooding the Carbonator. This regulator is not supplied as standard equipment

- Before connecting water supply, drain approximately two gallons of water from supply to flush out foreign matter.
- It is recommended that a water filtering systems be installed to reduce “off” tastes and odors. Use a system that can filter out dirt particles 1 micron and larger. Also amoebic and giardial cysts, asbestos fibers and other similar contaminants.
- Connect water supply to the 3/8” barb of the fitting of the water-in tube. (see fig. 4, Labeled Water Supply)
- Secure with proper sized “O” clamps.

4. CONNECTION OF “PRODUCT OUT” LINES

- Install the insulated bundled tubes on the 3/8” barb fittings.

- Connect syrup out lines (3/8” male barb) to a color-coded conduit. (Note which numbered line goes to which colored tube.) (see fig. 4)
- Secure connections with proper sized “O” clamps.
- Connect the recirculating soda line (3/8” tubing) to the barbed fitting coming from the insulated pump. (see fig. 4) Labeled “Soda Return”.
- Connect the other 3/8” line to the barbed fitting on the soda coil. Labeled “Soda Out”.

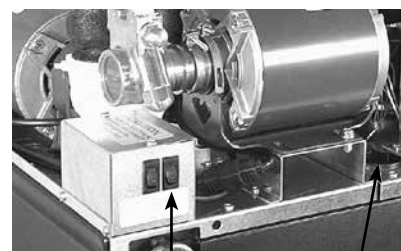

Fig. 3
Control Box Switches Filling the Water Bath

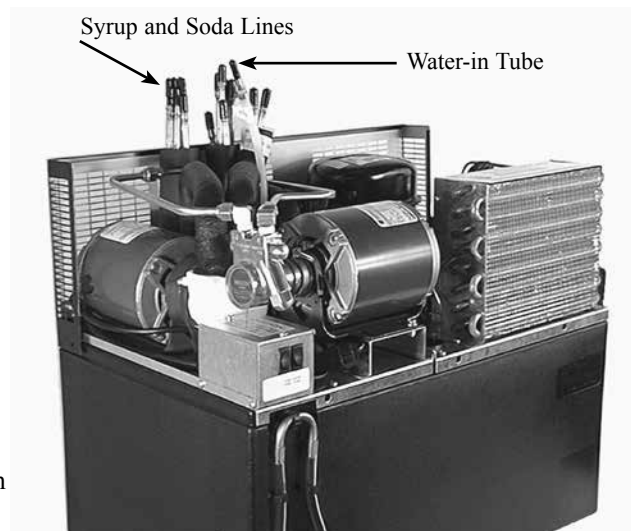

Fig. 4 Connection of Water in Line

5. CONNECTION OF “PRODUCT IN” LINES

- Install the 1/4” I.D. braided tubing from the syrup supply location to the 1/4” male barb connections on the unit. Use tie wraps to neatly bundle supply lines.
- Secure lines to product coils with “O” clamps.

6. CONNECTION OF CO2 CYLINDERS

- Mount the regulator assembly conveniently near the product supply and CO2 cylinder.
- Use either a regulator with a wall mounting bracket or mount directly to the cylinder.
- An extension tube is mounted to the carbonator tank with 1/4" barb fitting for ease of connection. Measure and cut a length of 1/4" I.D. braided flexible tubing to go from the CO2 regulator to the carbonator extension tube (labeled C02). (Leave enough line to go through the top cover of the unit.)
- Measure and cut 1/4" I.D. braided flexible tubing for each syrup gas line. Connect one end to the regulator manifold and the other end to syrup supply.

7. START-UP OF DISPENSING SYSTEM

- Open main water supply valve.
Purge air from carbonator by lifting relief valve.
- Turn on "CARB" switch. (see fig. 3)
- Close all CO2 regulators.
- Open the valve on the CO2 cylinder. (The high pressure gauge will read about 800 P.S.I.)
- Adjust the carbonator regulator to 100 P.S.I.
- Operate a valve until carbonated water flows freely (without spurting).
- Adjust the syrup regulator to 50 P.S.I.
- Adjust diet syrup regulator (if used) to 12 P.S.I.
- Check all connections for leaks.
- Insulate and tape all exposed refrigerated conduit lines.
- After refrigeration systems has cycled off once, turn on recirculating switch. (Full ice bank is required to cool tower.) Replace top cover.
- Follow standard brixing procedures.



Fig. 5 GLASTENDER TEMPLOCK Insulated Conduit

8. INSULATED CONDUIT (Figure 5)

- The GLASTENDER TEMPLOCK insulated tube conduit is recommended for this remote Post-Mix application. This manufactured conduit maximizes the cooling performance of the system.
- Conduit may be run under floors, over ceilings, under the counter or bar, and will not kink in an 18-inch radius around a corner.
- When conduit is to be run across ceilings or under counters, always place conduit straps every 3-ft. to prevent sagging.
- On runs through ceilings that are also used for air conditioning return ducts, check local fire codes. They may require that the conduit be covered with a fire rated metal flex duct.
- It is recommended that the chase protrude above the floor level a minimum of 2 inches and should be sealed off once the installation has been completed. By sealing off the floor chase, you eliminate the possibility of foreign matter being spilled into it, which could permeate the conduit.

1. WATER LEVEL

- Due to evaporation, it is necessary to periodically check the water level of the bath. Add water as required.
- A low water level results in noisy operation and reduces cooling capacity.

2. CLEANING HINTS

- Clean external cabinetry with mild soap and warm water.
- Do not use strong bleaches or detergents.
- Do not use steel wool, scouring pads, abrasives, etc.
- Do not use hot water; this may damage certain materials.
- The refrigeration condenser should be cleaned with a soft bristle brush or a vacuum cleaner.

3. WATER BATH CLEANING AND DRAINING

- Disconnect main power.
- Remove top cover.
- Remove drain tube holding clamps and drain water from bath.

Note: Because the water bath tank is well insulated, it may take hours for the ice to melt naturally. The ice can be melted faster by refilling the tank with warm water.

- Disconnect the refrigeration deck power cord from the control box.
- Remove six (6) hold-down screws (shipping screws).
- After ice has melted, lift out the refrigeration deck by its handles.
- Clean the evaporator coil with soap or detergent using a soft brush. Rinse with clean water.
- Remove the rear panel for easier access to this base. This is accomplished by removing 2 screws on each side and 4 screws across the back.
- Make sure CO₂, water and syrup supply are all shut off.
- Depressurize the carbonator by lifting its relief valve.
- Remove five (5) hold-down screws (shipping screws).
- Lift out motor and pump deck.

- Clean coils and inside of tank with soap or detergent and rinse with water.
- Replace motor and pump deck.
- Replace refrigeration deck. Plug cord from refrigeration deck back into control box.
- Replace rear panel.
- Replace drain tube in holding clamps making sure hole in plastic/copper elbow is on top.
- Refill tank until water comes out of the overflow tube.
- Replace top cover.

4. SANITIZING WATER CIRCUITS

- Turn on water and flush at least five gallons through entire system (plain and carbonated water circuits).
- Fill a five-gallon pressure tank with a mild cleaning solution (1 lb. baking soda to 5 gallon of water).
- Flush lines with this cleaning solution by connecting soda water line to outlet of tank (baking soda) and pressurize with CO₂.
- Fill a five-gallon pressure tank with a chlorine solution (1-½ oz. Clorox to 5 gallons of water).
- Flush lines with this chlorine solution to prevent mold and bacteria growth by connecting soda water line to outlet of tank (chlorine) and pressurizing with CO₂ Connect water lines to the dispenser.
- Flush entire system with potable water (suitable for drinking) to remove all trace of chlorine solution.

5. SANITIZING SYRUP CIRCUITS

- Uncouple syrup line from syrup container.
- Connect syrup line to tank filled with potable water (suitable for drinking). Pressurize at least 2 gallons of water through each syrup circuit.
- Connect 5-gallon pressure tank containing soda solution (1 lb. Baking soda to 5 gallons of water) and flush through syrup circuits.
- Repeat above procedure using chlorine solution (1-½ oz. Clorox to 5 gallons of water) to prevent mold and bacteria growth.
- Repeat above procedure using potable water (suitable for drinking) to flush system of all trace of chlorine solution.

<u>PREVENTIVE MAINTENANCE SCHEDULE</u>		
Daily	Syrup Tank Connectors	When Cleaning Tanks Rinse Both Quick Connects In Clean Warm Water.
Daily	Dispensing Valves	Wash Nozzle And Diffuser In Warm Soapy Water And Rinse In Warm Water
Daily	Dispensing Towers	Wash With Mild Detergent And Warm Water, Then Wipe Dry. Flush Drain With Warm Water
Twice Weekly	Dispensing Tower Brix Check	Follow Standard Brixing Instructions
Weekly	Remote Cooler	Wash With Mild Detergent And Wipe Dry
Weekly	System Pressures	Review Pressure Gauges For Proper Settings
Monthly	Remote Cooler Air Cooled Condenser	Clean Condenser With A Soft Bristled Brush Or Vacuum Cleaner
Every 6 Months	Syrup Lines	Follow "SANITIZING SYRUP CIRCUITS" Instructions
Every 6 Months	Water Lines	Follow "SANITIZING WATER CIRCUITS"
Every 6 Months	Water Bath	Follow "WATER BATH DRAINING AND CLEANING" Instructions
Every 6 Months	Lubrication	Lubricate Circulating And Carbonator Pump Coupling With 3-5 Drops Of SAE 20 Non-Detergent Oil

1. POOR CARBONATION

- Make sure faucet and nozzle are clean.
- Temperature of the soda water in cup affects the amount of carbonation retained in water. If drink is above 40 degrees F. only 92% is retained. When taking drink temperature, always dispense at least 16 ounces of product to get a true reading.
- Flooded carbonator caused by water being supplied at a higher pressure than the CO₂ pressure. Check pressure regulator system. Make sure it is at least 35 P.S.I. lower than CO₂ pressure. The CO₂ pressure should be 100 P.S.I.G.
- Any substance with an oil base will knock out carbonation. Make sure no pipe dope or compound is on any fitting. Always use teflon tape.
- Ice that is super cold will cause foaming problems and a loss of carbonation. Bring ice to melt temperature (28 degrees) before using.

2. BAD TASTE IN BEVERAGE

- Pipe compound or pipe dope can impart a taste to the water. Remove piping and clean joints. Replace piping using only teflon tape.
- Carbon dioxide (CO₂) gas is odorless, colorless, and tasteless. If CO₂ gas contains any oil or sludge from filling tanks, a bad taste could result.
- Soda water reacts to brass or copper and becomes toxic. Remove any brass or copper object coming in contact with soda water. Replace with polyethylene or stainless steel.

3. NOISY CARBONATOR PUMP

- Check to see that filter and/or strainer are not clogged, and water valve to unit is wires from switch. With switch in "ON" fully opened.
- Incoming water supply to unit should be 3/8" I.D. minimums.
- Be sure pump and pump motor are properly aligned and the clamp is tight.
- Broken vanes in pump requiring pump replacement.

4. NOISY RECIRCULATING PUMP

- Check for restrictions in recirculating lines.
- Be sure pump and pump motor are properly aligned and clamp is tight.
- Broken vanes in pump requiring pump replacement.

5. COMPRESSOR WILL NOT RUN

- Verify that switch is in "ON" position.
- Check all wire junctions and tighten any loose connections.
- Replace ice-bank control.

6. COMPRESSOR RUNS BUT STOPS

- Air-cooled: Clean condenser
- Water-cooled: Verify adequate water supply.

7. COMPRESSOR RUNS-WILL NOT COOL

- Check for refrigerant leaks
- Replace condenser.

8. CARBONATOR PUMP MOTOR WILL NOT RUN

- Check fuse and supply switch. Make sure switch is on.
- Check switch on beverage system by disconnecting power supply. Remove 2 wires from switch. With switch in "ON"
- Remove 2 wires from switch. With switch in "ON" position, connect continuity tester to both terminals of switch. If no continuity, replace switch.
- Check circulating pump to be sure it turns freely by hand. If not, replace it.
- With pump removed and proper voltage supplied to the motor and it fails to run, it is defective and must be replaced.

9. PUMP LEAKING WATER

- Check for worn seal. If so, replace pump
- Pump must be insulated properly to prevent condensation.

10. WARM BEVERAGE

- Check for defective circulating pump. If so, replace it.
- Check water bath temperature (30° +/-2) and level.
- Clean condensor coil at air intake.

11. WATER IN BATH FREEZING COMPLETELY

- Ice-bank control defective and must be replaced.

12. NOISE IN WATER BATH

- Water level in bath low. Refill to proper level.

1/3 HP Post-Mix Remote

LC84 CONQUEST



LC84 CONQUEST

STANDARD FEATURES

- Modular lift-out refrigeration system for easy in-field service
- High capacity refrigeration and recirculation for high volume and remote long distance installations
- CFC-free R134a refrigerant
- Light-weight, roto-molded water bath with drain
- Up to six (6) syrup circuits with recirculating soda and water
- Polyurethane foamed-in-place insulation
- Self-contained carbonation system



NOTE: Clearance of 12" required around unit for maintenance and air flow.

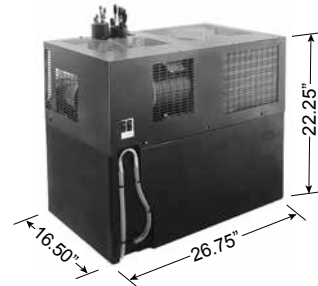

SPECIFICATIONS

Dimensions

- Height - 22.25" (56.5 cm)
- Width - 26.75" (67.9 cm)
- Depth - 16.50" (41.9 cm)

Circuits

- Six (6) syrup, plus soda and water

Electrical

- 115V/60 Hz/16.0 Amps
- 230V/50 Hz/8.0 Amps
- 20 amp circuit required
- Includes a 6-foot grounded cord

Refrigeration

- 1/3 HP, R134a refrigerant

Water Bath

- Roto-molded polyethylene

Insulation

- Polyurethane foamed-in-place

Ice Bank

- 35 lbs (15.9 kg)

Maximum Draw Rate

- 6 oz drinks - 460 at 4 per min
- 12 oz drinks - 253 at 2 per minute
- Based on a 40°F (4.4°C) or below dispensed drink, ambient and incoming syrup and water at a temperature of 75°F (23°C)

Recovery

- 3 six ounce drinks per minute

Pull Down

- 6.9 hours operational

Maximum Distance to Dispensers

- 150 ft (46 m)

Carbonator

- Integral cold carbonator

Carbonator Pump

- 100 gph (378 lph)

Carbonator Motor

- 1/3 HP (.25 kW)

Circulating Pump

- 70 gph (265 lph)

Circulating Motor

- 1/3 HP (.25 kW)

Shipping Weight

- 143 lbs (65 kg)

Operating Weight

- 261 lbs (119 kg)

Shipping Cube

- 9.8 cu ft (.278 cu m)

Options

- 4" Adjustable legs (up to 5-1/2")

SPECIFICATIONS

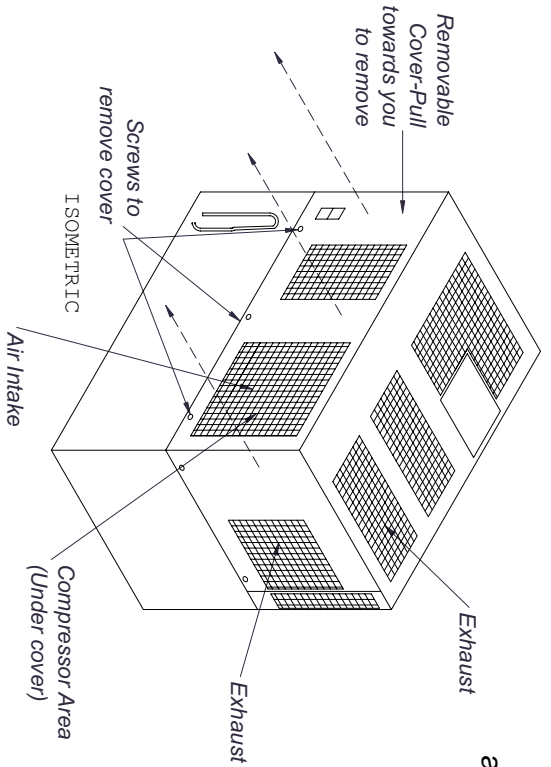

allow 20" clearance above unit to service compressor

note: compressor failure due to restriction or blockage of air flow will void warranty.

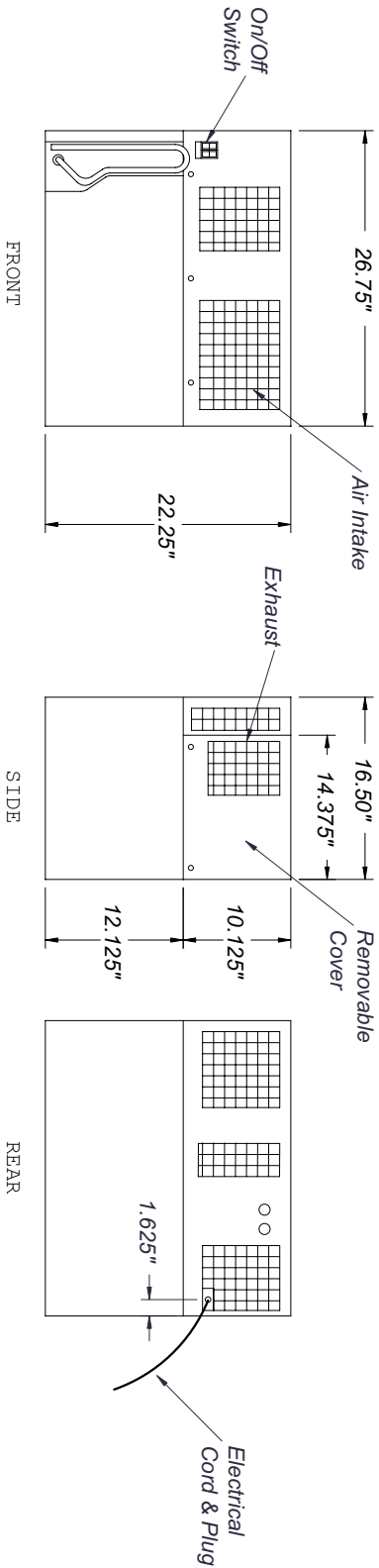
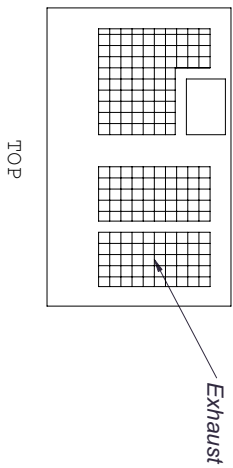

NOTE: Air flow & proper ventilation required for compressor
 12" gap on sides for ventilation & to remove cover,
 3" gap in rear for recirculation line hook-up, and 20"
 gap on top for ventilation and servicing.

Top, front, & sides are one piece and are removable for servicing the compressor.

Glas tender TYPICAL INSTALLATION DIAGRAMS

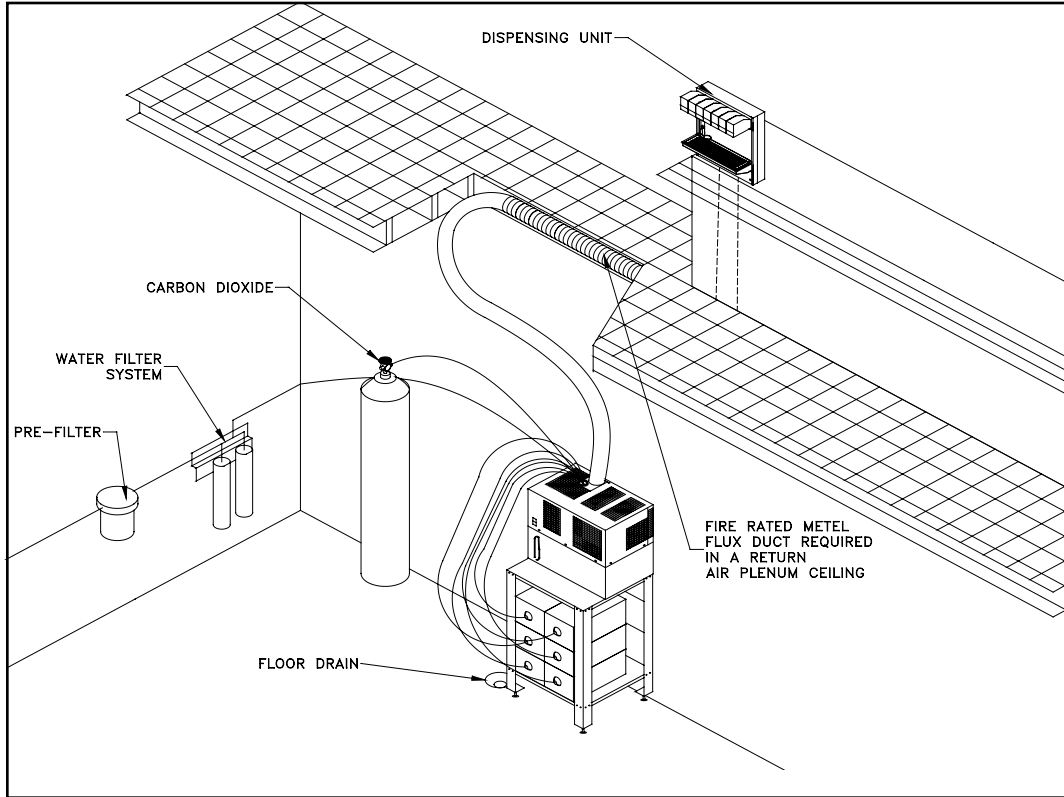

Typical Installation - Using bag-in-box syrup system

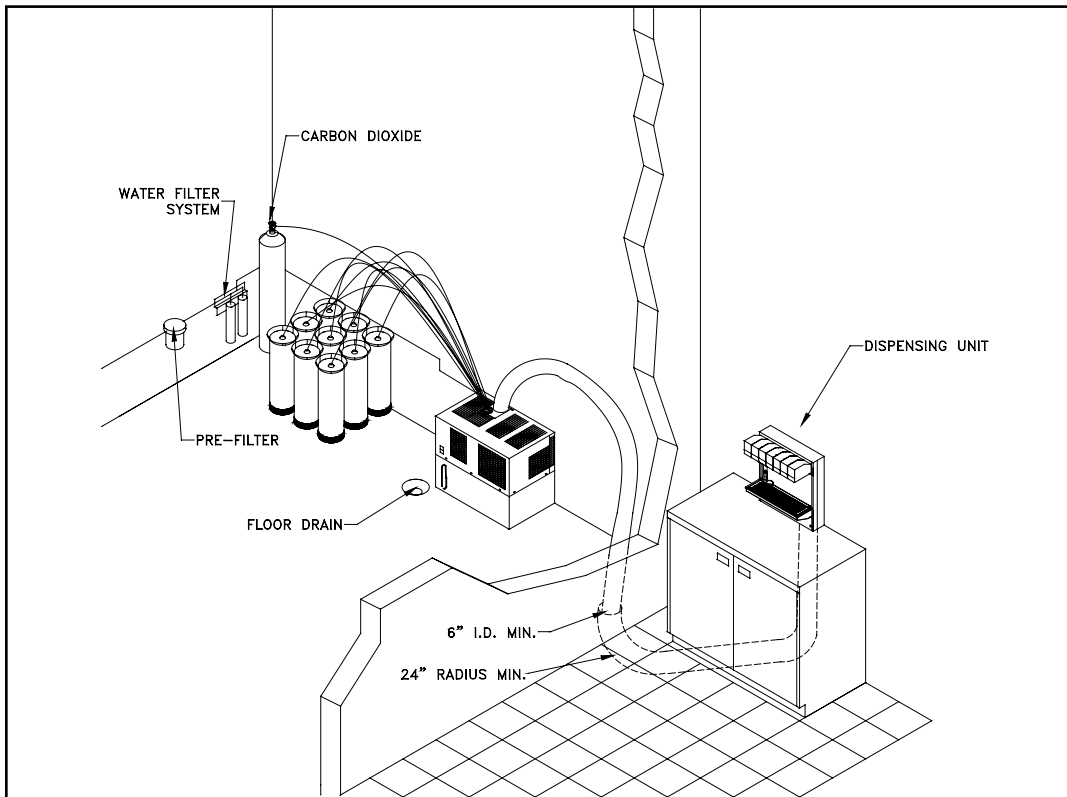

Typical Installation - Using product tank syrup system

WIRING DIAGRAM

115v/60hz 20 amp RECEPTICAL REQUIRED

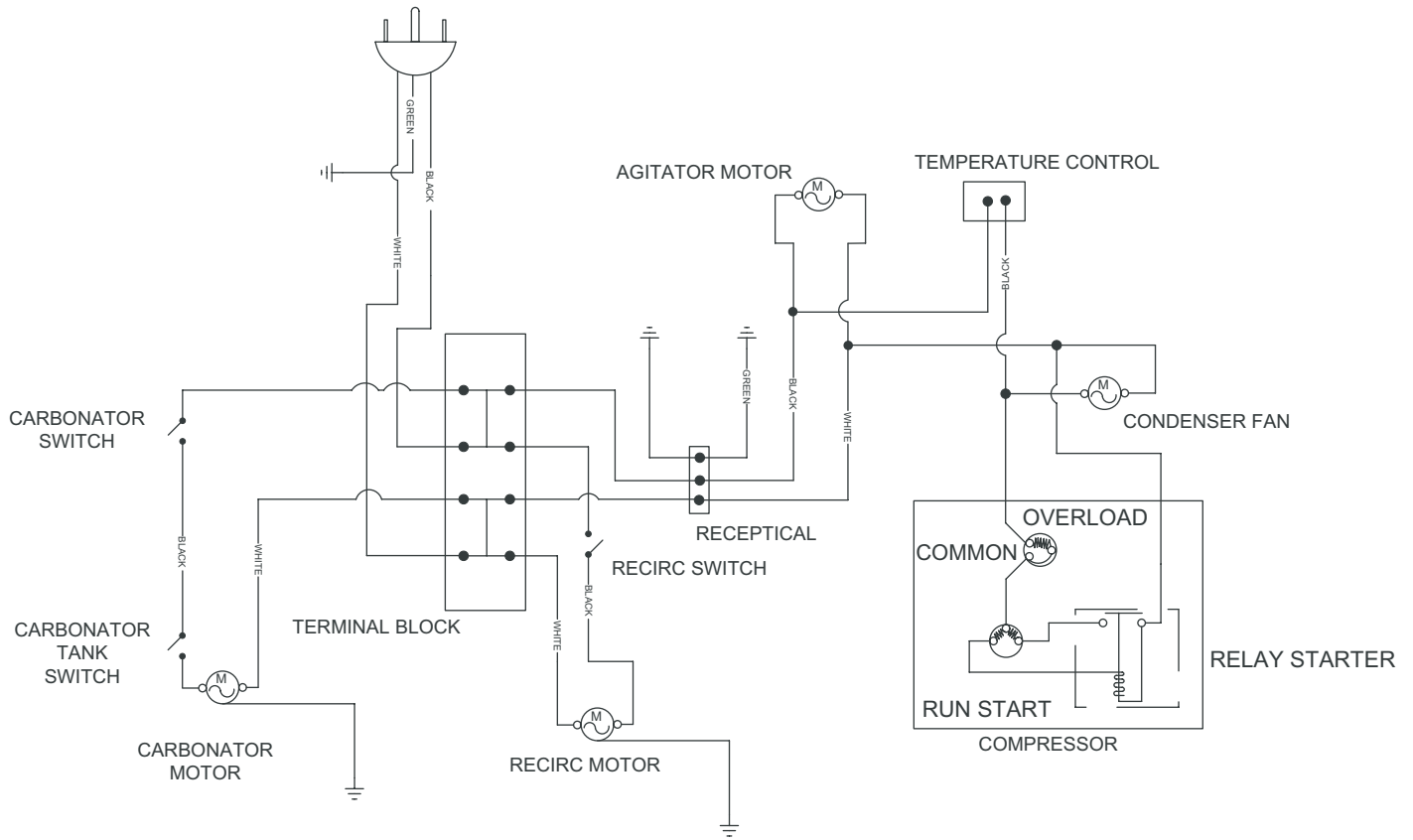

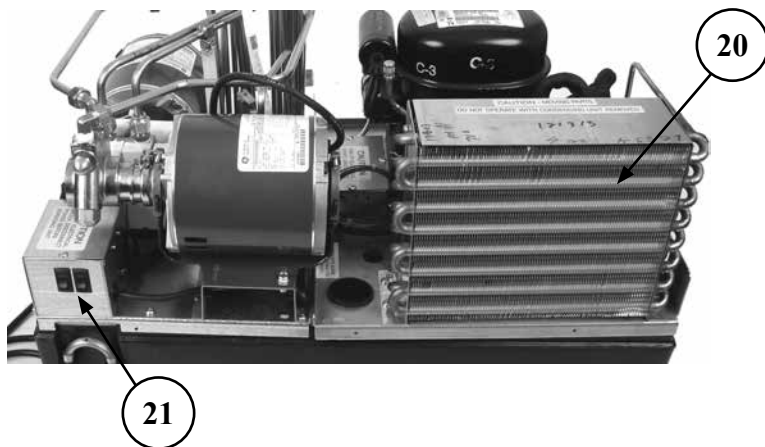
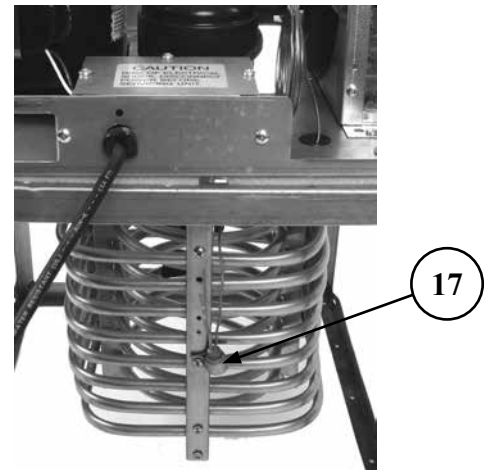
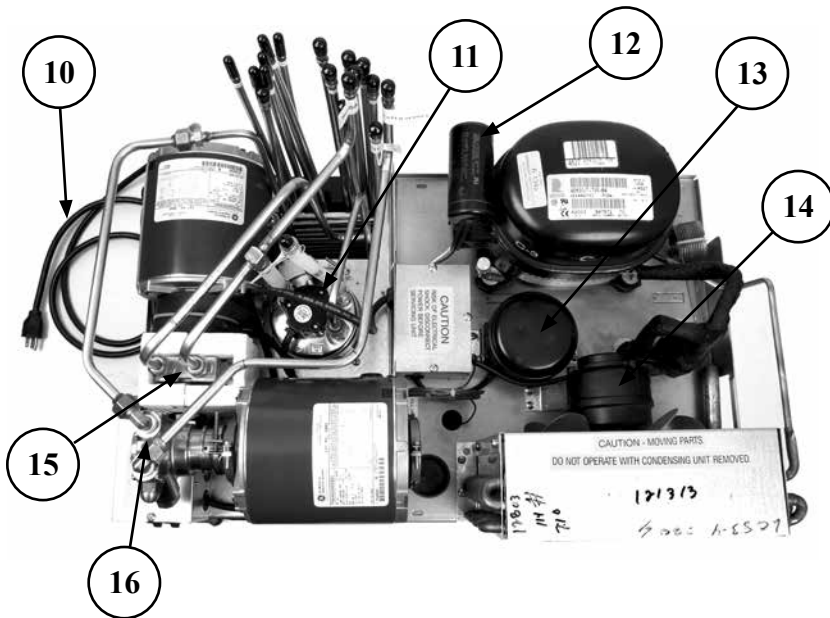
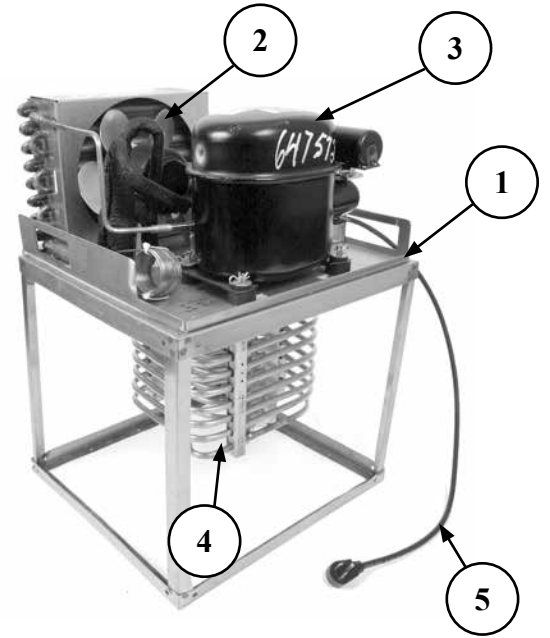
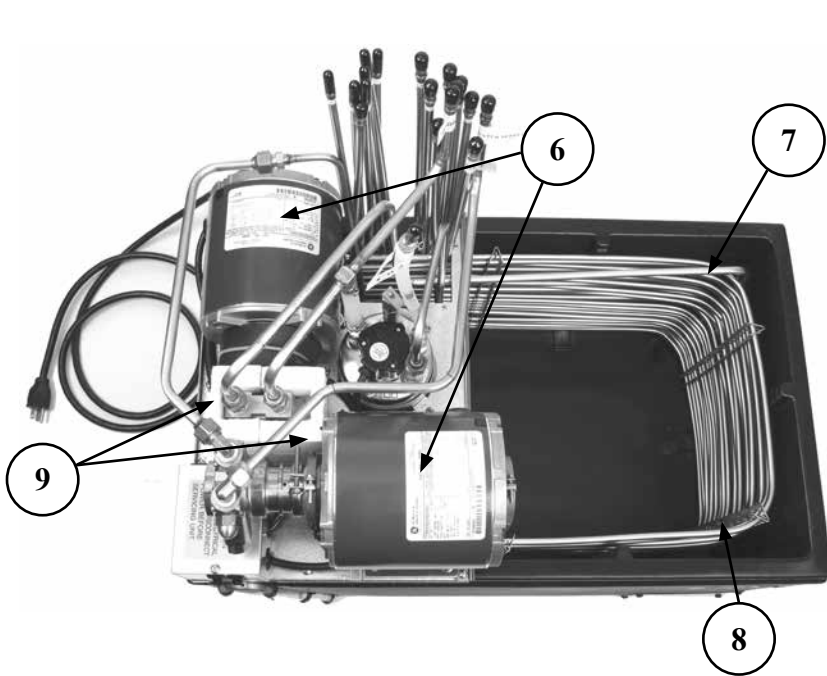

LC84 COMPRESSOR AND RELATED PARTS



<u>PART NO.</u>	<u>OLD PART NO.</u>	<u>DESCRIPTION</u>	<u>PRICE</u>
1. 09000416	GT-037436	Refrigeration Deck Assembly Complete	\$985.00
2. 09000299	GT-032805	Condenser Fan Blade	10.50
3. 06001439	GT-035014	1/3 HP Compressor R-134A	405.00
4. 09000291	GT-032598	Evaporator coil, LC83, 84 & 85, Copper	110.00
5. 06001313	GT-031400	Condensing unit power cord	20.00
6. 09000340	GT-035119	Recirculating pump	350.00
7. 09000257	GT-006552	Complete basket assembly	508.00
8. 09000482	GT-006554	Soda circuit only, tubing coil	139.00
9. 06001595		Insulation, pump, white, set of 2 pieces	9.00
10. 09000261	GT-031404	104" exterior power cord	20.00
11. 09000412	GT-037112	Carbonator tank, 115V	415.00
12. 09000479	GT-034114	Relay, compressor	20.00
09000480	GT-031211	Compressor overload	11.50
09000481	GT-032210	Compressor start capacitor	10.00
13. 09000338	GT-035116	Agitator motor, stainless steel shaft	170.00
14. 09000336	GT-035109	Condenser fan motor	85.00
09000463	GT-041306	Accumulator, cap tube assembly	40.00
15. 09000327	GT-034517	Soda Water pump	350.00
16. 09000328	GT-034518	Water pump	190.00
17. 09000304	GT-033208	Ice bank control	100.00
18. 09000410	GT-037110	Main cabinet tank	130.00
19. 09000395	GT-036135	Complete cover, black vinyl clad	78.00
20. 09000293	GT-032615	Condenser coil	125.00
21. 06001412	GT-033421	Rocker switch	4.00
06001409	GT-033304	Snap-in receptacle	5.00
09000436	GT-036497	Plug, black plastic, 1 3/4" hole	.50

APPLICABLE TO ALL PRODUCTS SOLD WITHIN THE UNITED STATES AND CANADA

Glastender, Inc. warrants all products to be free of defects in material and workmanship. One-year labor and parts warranty applies to all glasswashers, self-contained refrigeration models, and BDS model bottle disintegration units. In established areas, a start up is included with GT-24 and GT-30 model glasswashers. Warranty is effective for one year from the date of installation or up to 18 months from date of factory shipment, whichever occurs sooner. Glastender, Inc. will replace any part or assembly found defective under normal use and service.

For warranty labor claims beyond 15 months from the date of factory shipment, proof of date of installation or occupancy must be provided. Authorization for labor must be obtained from Glastender within the warranty period and prior to the service being performed.

Labor warranty applies to the United States and Canada only.

Remote refrigeration models and beer line chillers include a one-year parts warranty only. There is no labor warranty on these products.

Field replacement parts not covered under the original warranty include a 90-day part warranty from the date of installation.

FOUR YEAR ADDITIONAL COMPRESSOR WARRANTY: Glastender will warrant to the original user the compressor for all self-contained refrigeration models for an additional four years following the regular one-year warranty period. This plan applies to the compressor only.

A completed warranty claim form **MUST** accompany all returned defective parts or assemblies. Upon request, a defective part or assembly must be returned to Glastender, Inc., Saginaw, Michigan, with all transportation and delivery charges prepaid. Warranty repairs or replacements will be shipped FOB factory in Saginaw, Michigan. Reimbursement for applicable freight charges covers ground service only.

Glastender provides in-warranty repairs during a service company's regular working days and hours. There is no provision for payment of a premium rate during "overtime" hours. When warranty service is requested during other than normal working hours, the end user will be charged the premium portion of the overtime rate.

The warranty covers substantiated travel expenses for up to 2 hours / 100 miles round trip up to a maximum of \$150. Any additional costs due to installations that require extra work, time, or travel to gain access for service are the sole responsibility of the equipment purchaser. Any exceptions to these travel and access limitations must be pre-approved by a factory representative.

The warranty does not cover door gaskets, chemical tubing, pump squeeze tubing, and/or any equipment subjected to accidents, freight damage, alterations from the original design, improper power and/or plumbing hookups, improper chemical use, general misuse, or lack of routine required maintenance as determined by Glastender, Inc. Installation, normal control adjustments, general maintenance, correcting an installation error, or service calls that reveal the unit is functioning normally will not be reimbursed under warranty.

Condenser coils on self-contained refrigeration products must be cleaned regularly. Failure to provide adequate air flow to a refrigeration unit will void the warranty.

Glastender shall not be liable for loss of use, revenue, or profit, or for any other indirect, incidental, special, or consequential damage including, but not limited to, product spoilage or loss.

This warranty is conditioned upon Glastender receiving notice of any defect subject to this warranty within sixty (60) days of its discovery by the end user or dealer. All products are warranted only for the initial place of installation. Removal of a product automatically terminates this warranty.

SECOND YEAR EXTENDED PARTS & LABOR WARRANTY:

Glastender's one-year parts and labor warranty on self-contained refrigeration units, excluding beer line chillers, can be extended to two years with the purchase of a two year parts and labor warranty. Specify part number EWR2 (\$150 net price) when ordering.

EXPORT WARRANTY - One year parts only.

EXCLUSION OF WARRANTIES

EXCEPT AS PROVIDED ABOVE, GLASTENDER MAKES NO WARRANTIES, EXPRESS OR IMPLIED, INCLUDING, BUT NOT LIMITED TO, ANY IMPLIED WARRANTY OF MERCHANTABILITY, FITNESS FOR A PARTICULAR PURPOSE OR NON-INFRINGEMENT.

LIMITATION OF REMEDIES AND DAMAGES If Buyer makes a valid and timely claim as outlined above, Glastender's liability and Buyer's remedies under this agreement will be limited solely to labor charges authorized and/or replacement or credit, at Glastender's option, with respect to Products returned at Buyer's expense within thirty (30) days after warranty repair. **GLASTENDER'S LIABILITY WILL IN NO EVENT BE GREATER IN AMOUNT THAN THE PURCHASE PRICE OF THE RETURNED PRODUCTS. GLASTENDER WILL NOT BE LIABLE UNDER ANY CIRCUMSTANCE FOR CONSEQUENTIAL OR INCIDENTAL DAMAGES, INCLUDING, BUT NOT LIMITED TO, LABOR COSTS EXCEPT AS COVERED UNDER OUR WARRANTY, LOST PROFITS OR THE LOSS OF PERISHABLE PRODUCTS RESULTING FROM THE USE OF OR INABILITY TO USE OUR PRODUCTS OR FROM OUR PRODUCTS' INCORPORATION INTO OR BECOMING A COMPONENT OF ANY OTHER PRODUCT. NEITHER PARTY WILL HAVE ANY NEGLIGENCE OR OTHER TORT LIABILITY TO THE OTHER, OR TO ANY THIRD PARTY, ARISING FROM ANY BREACH OF THIS AGREEMENT.**

GOVERNING LAW - JURISDICTION

The terms and conditions of an order are to be governed and construed according to the laws of the State of Michigan, without regard to conflict of laws principles. Buyer hereby consents to the jurisdiction and venue of the courts located in Saginaw County, Michigan.

No representative, distributor, dealer, or any other person is authorized to modify this warranty. This warranty replaces all other written or verbal warranties.

NOTE: Glastender, Inc.'s policy of constant quality improvement means that prices, specifications, and policies are subject to change without notice. Questions regarding this warranty should be directed to Glastender's Warranty Administrator.

04-19-17

IMPORTANT!!**Attention Service Companies**

Please review the important warranty information on this page. If you believe a service call should be covered by the factory, please call the factory for authorization between 8AM and 5PM EST, Monday through Friday.