

Parts Catalog

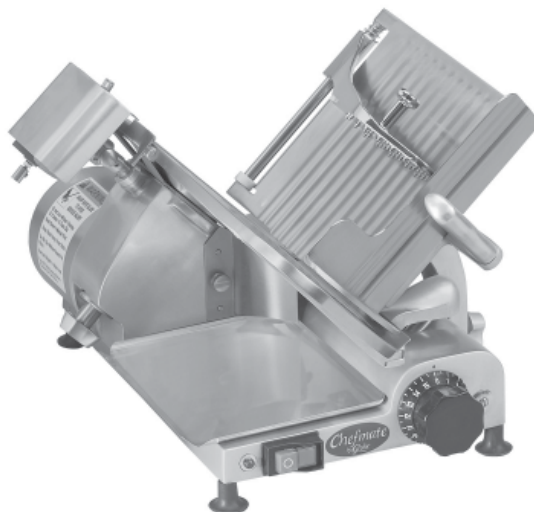

Model GC510

SLICING MACHINE

MODELS: GC510

11-10-22

IMPORTANT!

TO EXPEDITE SHIPMENT OF PARTS, ALWAYS SPECIFY MODEL, REV,
PART NUMBER, AND SERIAL NUMBER OF SLICER.

GLOBE FOOD EQUIPMENT COMPANY

2215 East River Rd.

Dayton, Ohio 45439

Parts Department

Toll Free 1-800-745-6238 • Fax (937) 290-0585

E-Mail: globeinfo@globeslicers.com

Website: www.globeslicers.com

Not for resale

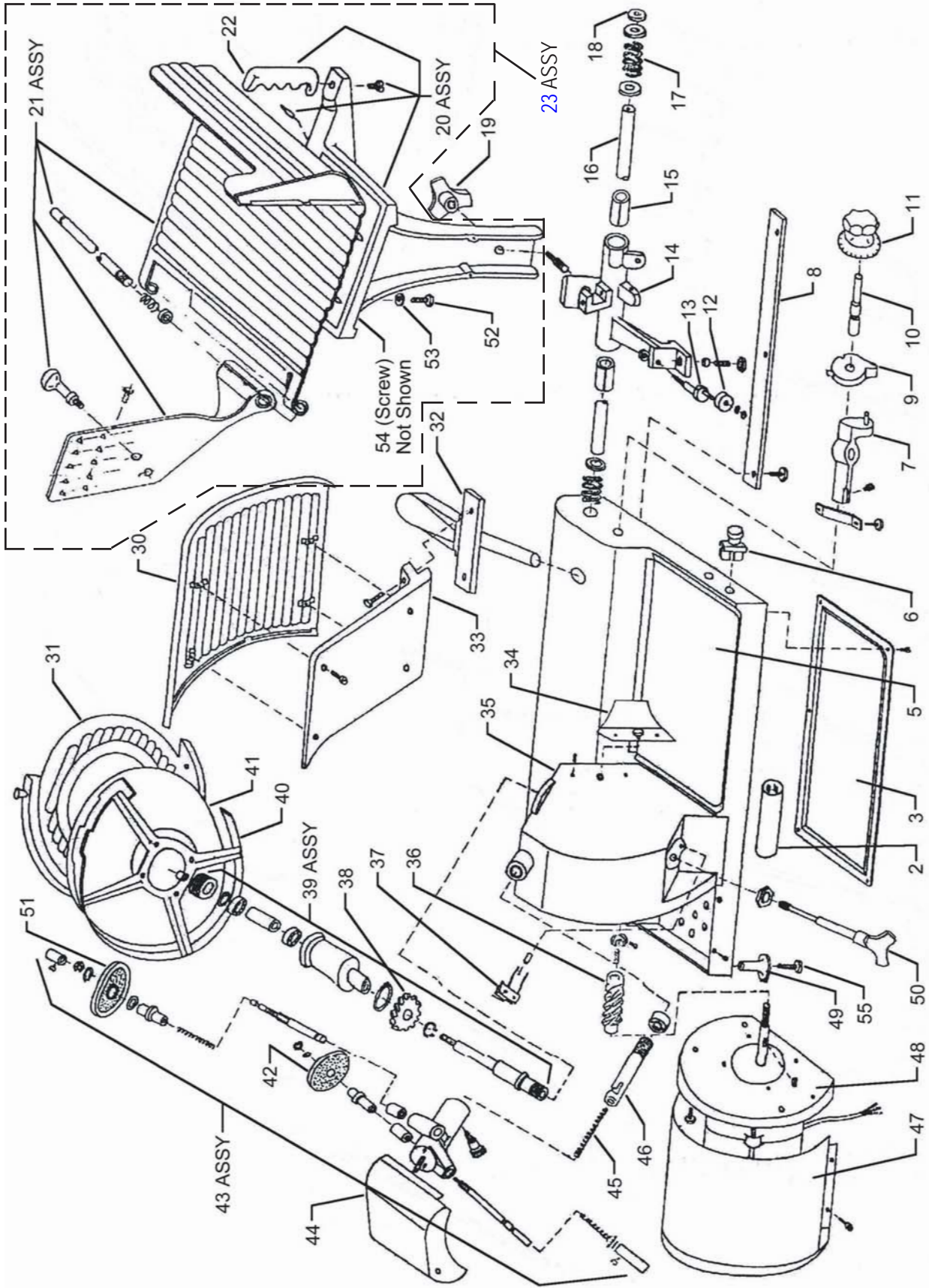

GC510 PARTS BREAKDOWN

GC510 PARTS LIST

Item Number	Part Number	Part Description
2	A16UF	Capacitor
3	A2509	Bottom Enclosure
5	A2501	Receiving Tray
6	AKJD17	On/Off Switch
7	A2518	Table Adjustment Cam Arm
8	A2513	Lower Support Bar
9	A2514	Indexing cam
10	A2519	Table Adjustment Knob Shaft
11	A150	Table Adjustment Knob
12	A2523	Roller
13	A2522	Roller Cam
14	A2525	Slide Assembly (Includes items 12, 13 & 15)
15	A2527	Slide Bushing
16	A2524	Upper Slide Bar
17	A2521	Slide Bar Spring
18	A2504	Slide Bar Washer
19	A2577	Chute Support Knob
22	A2583	Chute Assembly
30	A2535	Table
31	A2550	Knife Cover
32	A2532	Table Support Bracket
33	A2531	Table Support Bracket
34	A2505	Slice deflector
35	A2541	Gear Housing
36	A2564	Worm Gear
37	A1628	Microswitch
38	A293	Nylon Gear
39 ASSY	A2545	Bearing Assembly (Includes item 38)
40	A2555	Knife Rim Guard
41	A2544	Knife
42	A2666	Grinding Stone
43 ASSY	A2640	Sharpener Assembly (Includes items 42, 44 & 51)
44	A2645	Sharpener Cover
45	A2644	Sharpener Bracket Spring
46	A2691	Sharpener Bracket Spring
47	A2570	Motor Cover
48	A2560	Motor (Includes item 36)
49	A2503	Foot
50	A2710	Knife Cover Stud Knob
51	A2667	Truing Stone
55	A3002	Foot Screw
23 ASSY	A2580	Chute & Support Assembly (Includes items 20 ASSY, 21 ASSY, 52, 53 & 54)
20 ASSY	A2581	Chute Support Assembly (Includes item 22)
21 ASSY	A2585	Chute Handle
52	A3000	Chute Mounting Screw Short (2 Req'd)
53	A2579	Chute Mounting Screw Washer
54	A3001	Chute Mounting Screw Long

Electric diagram slicer GC510

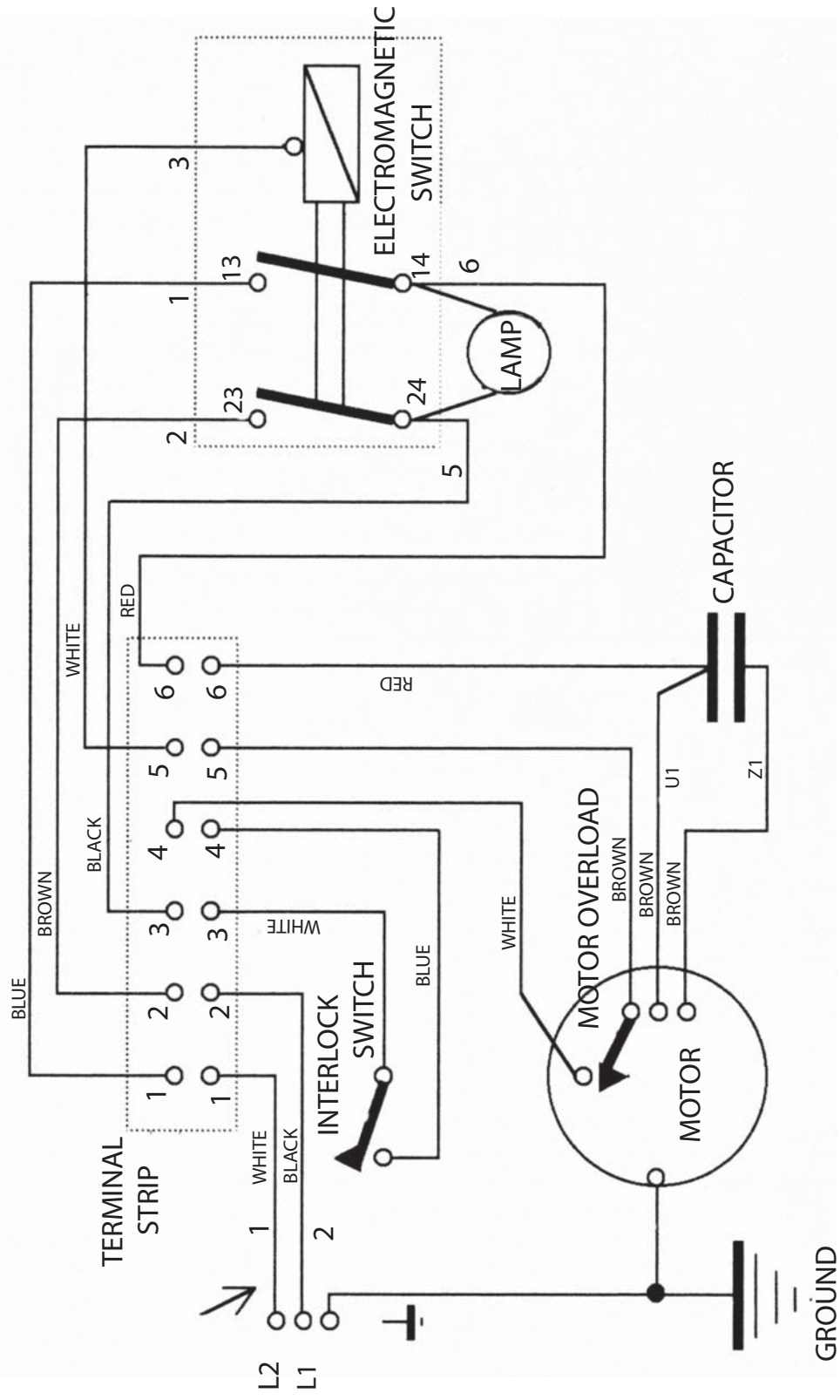

GLOBE FOOD EQUIPMENT COMPANY
 DAYTON, OHIO
 GC 510 WIRING DIAGRAM

JAN 28, 2002

