

# Crathco® Whipped Hot Chocolate Dispenser

## Operation and Instruction Manual

for

## Model HC-2

### Table of Contents

Introduction .....	1
Specifications.....	2
Installation and Start-Up Procedures.....	2
How to Dispense Hot Chocolate .....	3
Adjustments .....	3-4
Cleaning .....	4-5
Troubleshooting Guide .....	6-7
Rough-In Drawings .....	8
Exploded Views .....	9-10
Wiring Diagram .....	11
Parts List .....	12

**Prior authorization must be obtained  
from Grindmaster Corporation  
for all warranty claims.**



**GRINDMASTER™**  
CORPORATION

### **Grindmaster Corporation**

4003 Collins Lane  
Louisville, Kentucky 40245 USA  
(502) 425-4776 (800) 695-4500  
(800) 568-5715 (Technical Service)  
FAX (502) 425-4664  
[www.grindmaster.com](http://www.grindmaster.com)





# Introduction

We are pleased you have chosen Crathco's Whipped Hot Chocolate Dispenser for your hot chocolate service. You have chosen the finest engineered, most functionally sound and easy to operate piece of equipment available. The HC-2 is a manual push and hold dispense machine, producing 1 ounce of chocolate per second into any cup size. It will accommodate bag-in-boxes, cans or hoppers of chocolate syrup.

Inside the carton you should find:

- 1) HC-2 Whipped Hot Chocolate Machine
- 2) Plastic chocolate hopper (optional)
- 3) Drip tray
- 4) Operation and Instruction Manual

The HC-2 Whipped Hot Chocolate Dispenser is supplied complete with a 6 foot, 120V A.C. 3 wire cord and NEMA 5-20 plug. Plugging the unit into a NEMA 5-20R outlet (20 AMP receptacle) is the only electrical service required. Plumbing service requires a high temperature food grade water supply line. The water supply line is connected to a 1/4" male flare fitting in the rear of the unit. Installation should comply with the National Plumbing Code.

## HC-2 Hot Chocolate Dispenser Specifications

	Model HC-2
Finished Product Size	Variable due to manual push and hold button
Dispenser Rate	1 ounce per second
Drink Strength Ratio	Variable between 4:1 and 6:1 - factory set at 5:1
Hot Chocolate Dispenser Temperature	180 degrees F $\pm$ 5 degrees F
Production Capacity 120 degrees F water in 50 degrees F water in	(230) 5 oz. cups/hour (115) 5 oz. cups/hour
Power Requirement	1800 watts, 15 Amps
Electrical Service Plumbing Service	120 Volt a.c., 20 Amp. NEMA 5-20 outlet 0.75 GPM minimum, 30-75 PSI water supply line to 1/4" male flare fitting
Water Compartment	2 3/4 gallons
Initial Fill Time	Approximately 5 minutes
Dispenser Spout Clearance	6"
Overall Height	27"
Body Width	10 1/2"
Body Depth	17 1/2"
Product Compartment	10" H x 9" W x 10" D

# Installation and Start-Up Procedures

1. Remove all packing material around the chocolate dispenser.
2. Place the hot chocolate dispenser upright on a leveled table at location intended for operation.
3. Place the drip tray on the front of the dispenser; using the 2 locating tabs on the sides of the tray.

## Water Inlet Connection:

1. An experienced plumber or equipment installer should connect the dispenser to a properly sized water line. Water supply should be 0.75 GPM minimum, 30-75 PSI.
2. Installation should comply with the National Plumbing Code.
3. The water supply line connects to the male flare found on the rear of the unit, using a 1/4" female flare nut.
4. Copper or brass tubing or stainless steel braided teflon lined or similar high temperature food grade hose should be used for the water line. Include extra length of water supply line to allow room to move the unit for cleaning.
5. Hot or cold water hookup can be used. Hot water will increase the production of the dispenser.
6. Be sure to flush the supply line before making the connection to dispenser.
7. A shut-off valve and union should be in the supply line near the dispenser.

**Caution: Do not use low temperature plastic tubing for water supply line.**

## Start-Up Procedures:

1. Plug the hot chocolate dispenser into a 120V 20 AMP, NEMA 15-20 outlet. A 6 foot, 3 wire cord with NEMA 5-20 plug is required.
2. Fill the hot chocolate dispenser with water. With power and water supplies to the dispenser turned "On", the dispenser will automatically fill with water. The water tank holds 2 3/4 gallons. It takes approximately 5 minutes to initially fill the water tank because of the auto refill system employed with this dispenser. When the water tank is full of water, filling will stop and the water level will be maintained at this point.
3. The water in the tank will automatically heat up to dispensing temperature. A 30-40 minute initial heat-up time is required when the dispenser is connected to 50 degree F water. If a hot water hookup is used, heat-up time will be shorter.

# How to Dispense a Cup of Hot Chocolate

1. Make sure the dispenser is filled with water and up to temperature.
2. Load a hot chocolate bag-in-box or fill hopper with chocolate syrup.

# How to Dispense a Cup of Hot Chocolate (cont.)

## Bag-in-Box Loading Instructions

- a. Lift the tab located on top of the box.
- b. Pull out the tube assembly with the retainer ring.
- c. Secure the retainer ring on the leading edge of the cutout.  
(Refer to Figure A)
- d. Insert the product box on the product shelf with the top side down and with the hose assembly toward the front.
- e. Remove the stopper cap from the box tube assembly.  
(Refer to Figure B)
- f. Connect the box tube assembly over the pump inlet tube.
- g. Remove the pinch clamp from the box tube assembly.  
(Refer to Figure C)
- h. You are now ready to draw product.

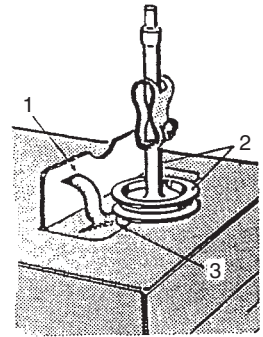

FIGURE A

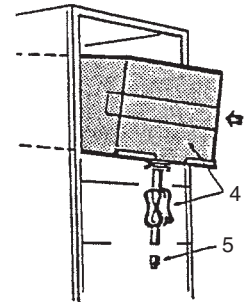

FIGURE B

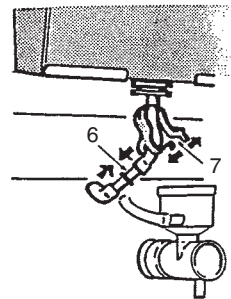

FIGURE C

3. Push and hold the dispense switch.

NOTE: It takes a few seconds to engage the hot chocolate pump rollers and to move the hot chocolate through the pump to the mixer assembly.  
(Refer to Figure D)

4. The dispenser is now ready for operation.

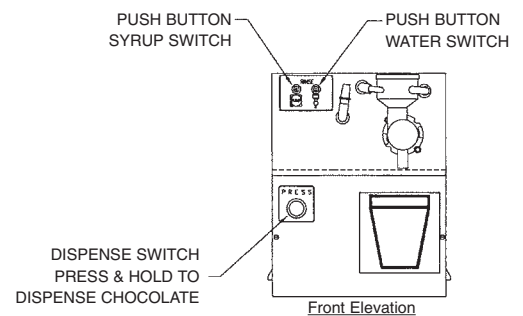

FIGURE D

## Adjustments

### Mix Ratio Adjustment:

The drink strength is adjustable from 4 parts water to 1 part chocolate to 6 parts water to 1 part chocolate. The dispenser is factory set at 5 parts water to 1 part chocolate.

1. Remove the hole plug.
2. Insert a screwdriver in the slot and turn clockwise for less water/stronger chocolate or counter clockwise for more water/weaker chocolate.  
(Refer to Figure E)

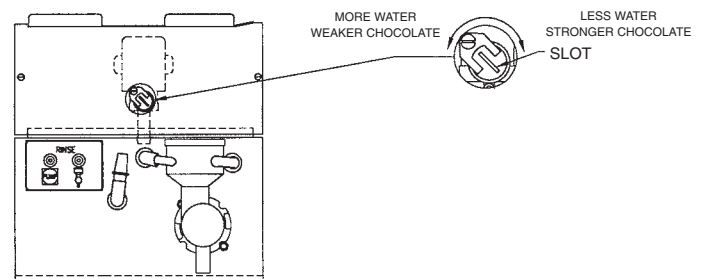

FIGURE E

## Thermostat Adjustment:



**WARNING:** Adjustments are to be done only by a qualified service technician. Water temperature setting is made in the top control section where electrically live parts are present. Your product supplier can be helpful in providing this expertise and making sure the correct dispense temperature is obtained.

Access to temperature adjustment is from the top.

To remove the top cover, remove the 2 screws and lift the cover off. Water temperature is factory set at 180 degrees F  $\pm$  5 degrees F.

Insert a screwdriver in the slot and turn clockwise to obtain a lower temperature and counterclockwise for a higher temperature (Refer to Figure F).

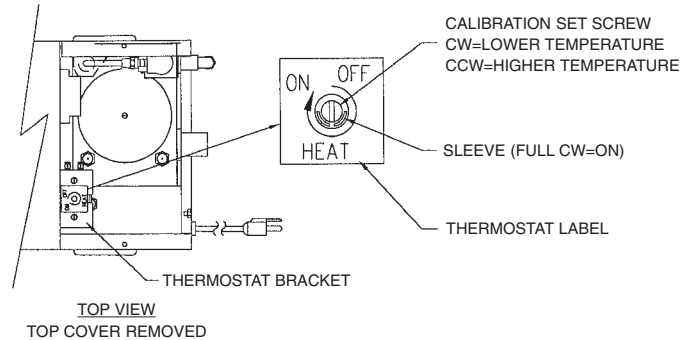

FIGURE F

## Cleaning

### Daily Cleaning

#### Mixing Chamber:

1. The stainless steel cabinet is kept clean with a damp cloth or a stainless steel cleaner.
2. Push the whipper rinse switch to flush until the water leaving the dispense spout is clear.

### Weekly Cleaning

#### Mixer:

(Refer to Figure G)

1. Disconnect the hoses to the mixer.
2. Lift off the cover.
3. Lift off the funnel cover.
4. Turn the whipping chamber clockwise and pull it off.
5. Pull off the whipping blade. Leave the backing washer on the metal shaft.
6. Wash all parts in mild soap. Rinse well and reassemble.

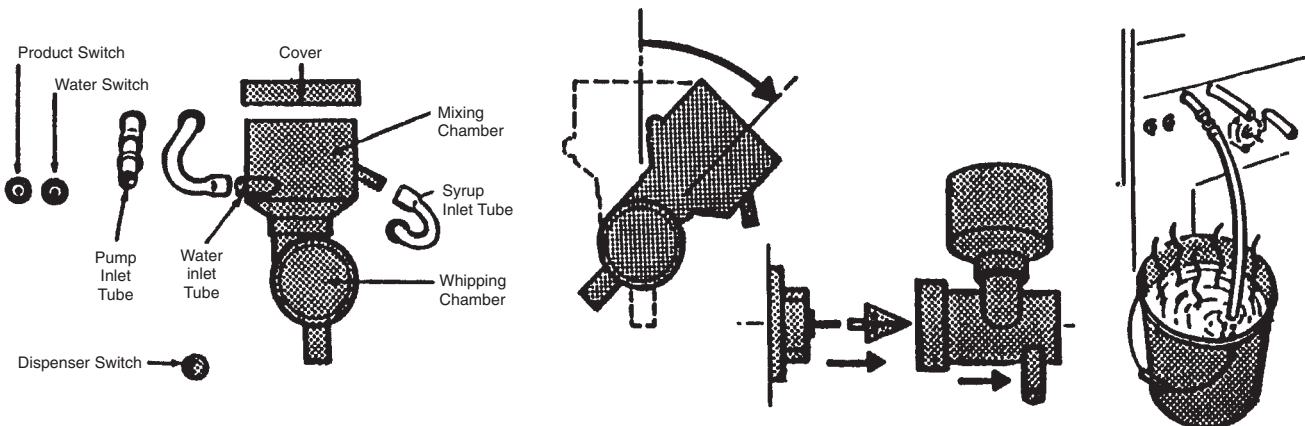

# Cleaning (cont.)

## Weekly Cleaning

### Syrup System:

1. Close the clamp on the product box tube and disconnect from the pump inlet.
2. Connect the cleaning tube to the pump inlet and drop the open end of the tube into a basin of hot, soapy water.
3. Push the pump rinse switch until clear water leaves the spout.
4. Repeat steps 3 with hot, clean water until there is no trace of soap.
5. Remove the cleaning tube and reconnect the pump inlet to the box tube. Open the clamp on the box tube.

NOTE: DO NOT UNDER ANY CIRCUMSTANCES USE CHLORINE BASE BLEACH OR CLEANING COMPOUNDS.

# Troubleshooting Guide

The following procedures must be performed by a qualified service technician.

Problem/Possible Cause	Service Check	Remedy
Consistent filling of water tank <ul style="list-style-type: none"> <li>Leaking fill solenoid valve</li> <li>Electrode lined up or faulty</li> <li>Faulty white common connection to ground</li> <li>Liquid level control faulty</li> </ul>	<ul style="list-style-type: none"> <li>Removing power to machine does not stop tank fill</li> <li>Jumper from C to high on probe side of board shuts fill off</li> <li>Jumper from COM on probe side of board to ground stops fill</li> <li>Jumper from High to COM on probe side of liquid level does not shut fill Off</li> </ul>	<ul style="list-style-type: none"> <li>Clean-replace fill valve</li> <li>Clean electrode rods. Check rods &amp; wiring; replace if necessary</li> <li>Tighten, clean, replace COM connection to ground</li> <li>Replace liquid level control</li> </ul>
Water not heating up <ul style="list-style-type: none"> <li>Thermostat Off</li> <li>Thermostat faulty</li> <li>Power relay faulty</li> <li>Heating element faulty</li> </ul>	<ul style="list-style-type: none"> <li>Visual</li> <li>Thermostat contacts do not close with sleeve clockwise and inner screw counter clockwise</li> <li>No voltage to heating element - 120V. across coil of relay does not pull in</li> <li>120V across heating element but no heat-element reads open with ohmeter</li> </ul>	<ul style="list-style-type: none"> <li>Turn thermostat sleeve clockwise</li> <li>Replace thermostat</li> <li>Replace power relay</li> <li>Replace heating element</li> </ul>
Nothing dispensed - water or chocolate - No whipper action <ul style="list-style-type: none"> <li>Dispense switch faulty</li> </ul>	<ul style="list-style-type: none"> <li>Switch reads open with ohmeter when switch is pushed</li> </ul>	<ul style="list-style-type: none"> <li>Replace switch</li> </ul>
No water dispensed or whipper action - Only chocolate is dispensed <ul style="list-style-type: none"> <li>Water switch faulty</li> </ul>	<ul style="list-style-type: none"> <li>Switch reads open with ohmeter when switch is in On position</li> </ul>	<ul style="list-style-type: none"> <li>Replace switch</li> </ul>
No water dispensed - Whipper works and chocolate is dispensed <ul style="list-style-type: none"> <li>Tank refill problem</li> <li>Kinked silicone tubing</li> <li>Dispense valve faulty</li> </ul>	<ul style="list-style-type: none"> <li>Check auto refill system</li> <li>Check tubing run to mixer assembly</li> <li>120V across input terminals on valve-no actuation</li> </ul>	<ul style="list-style-type: none"> <li>Clean-replace components</li> <li>Reroute tubing-unkink</li> <li>Replace coil or entire valve</li> </ul>
No whipper action - only water and chocolate are dispensed <ul style="list-style-type: none"> <li>Whipper motor faulty</li> </ul>	<ul style="list-style-type: none"> <li>120V across motor leads but motor does not run</li> </ul>	<ul style="list-style-type: none"> <li>Replace whipper motor</li> </ul>
No chocolate dispensed - Whipper works and some water is dispensed <ul style="list-style-type: none"> <li>No syrup to pump</li> <li>Kinked pump tubing</li> <li>Syrup pump faulty</li> </ul>	<ul style="list-style-type: none"> <li>Check syrup container</li> <li>Check tubing runs</li> <li>120V across pump motor leads, pump does not run; check for jammed rollers</li> </ul>	<ul style="list-style-type: none"> <li>Replenish syrup supply</li> <li>Unkink, reroute, replace</li> <li>Replace syrup pump-Unjam rollers</li> </ul>
Constant dispense - chocolate, water and whipper action <ul style="list-style-type: none"> <li>Dispense switch faulty</li> </ul>	<ul style="list-style-type: none"> <li>Switch reads closed with ohmeter with switch in the Off position</li> </ul>	<ul style="list-style-type: none"> <li>Replace switch</li> </ul>
Constant water dispense or drip <ul style="list-style-type: none"> <li>Dispense valve faulty</li> </ul>	<ul style="list-style-type: none"> <li>Dispense or drip continues with power Off</li> </ul>	<ul style="list-style-type: none"> <li>Clean, rebuild; replace dispense valve</li> </ul>

## Troubleshooting Guide (cont.)

Problem/Possible Cause	Service Check	Remedy
Chocolate is dispensed or constantly dripping <ul style="list-style-type: none"><li>• Syrup pump rollers not engaging silicone tubing</li><li>• Pump tubing faulty</li></ul>	<ul style="list-style-type: none"><li>• Check for syrup pump rollers in “storage” position or weak springs</li><li>• Check for holes in tubing or loose connections to break vacuum</li></ul>	<ul style="list-style-type: none"><li>• Rotate pump to engage rollers or replace pump</li><li>• Replace pump tubing-check connections</li></ul>

If you still need help, call our Technical Service Department at (800) 568-5715 (USA or Canada) or 1-502-425-4776, Monday through Friday, 8 am - 6 pm EST, or an authorized service center in your area. Please have the model and serial numbers ready so that accurate information can be given.

Prior authorization must be obtained from Grindmaster Corporation’s Technical Services Department for all warranty claims.

# Rough-In Drawings

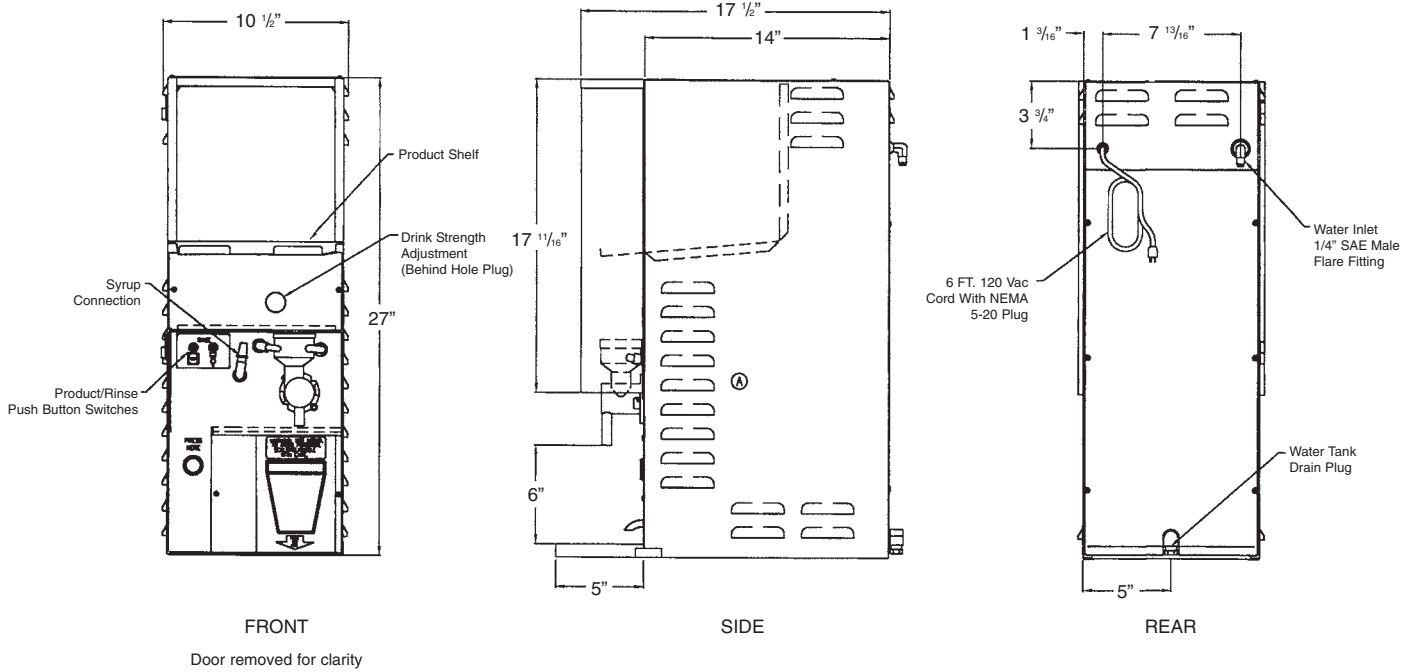

## UTILITIES

### Water Connection

- 1.) Hot or Cold Supply
- 2.) .75 GPM Minimum Flow At Unit  
30 to 70 PSIG

### Electric

- 1.) 120 AC, 20 Amp Service Required
- 2.) 1800 Watt Tank Heater, 15 Amp  
Total Load, Approx.

# Exploded View Whipper Assembly

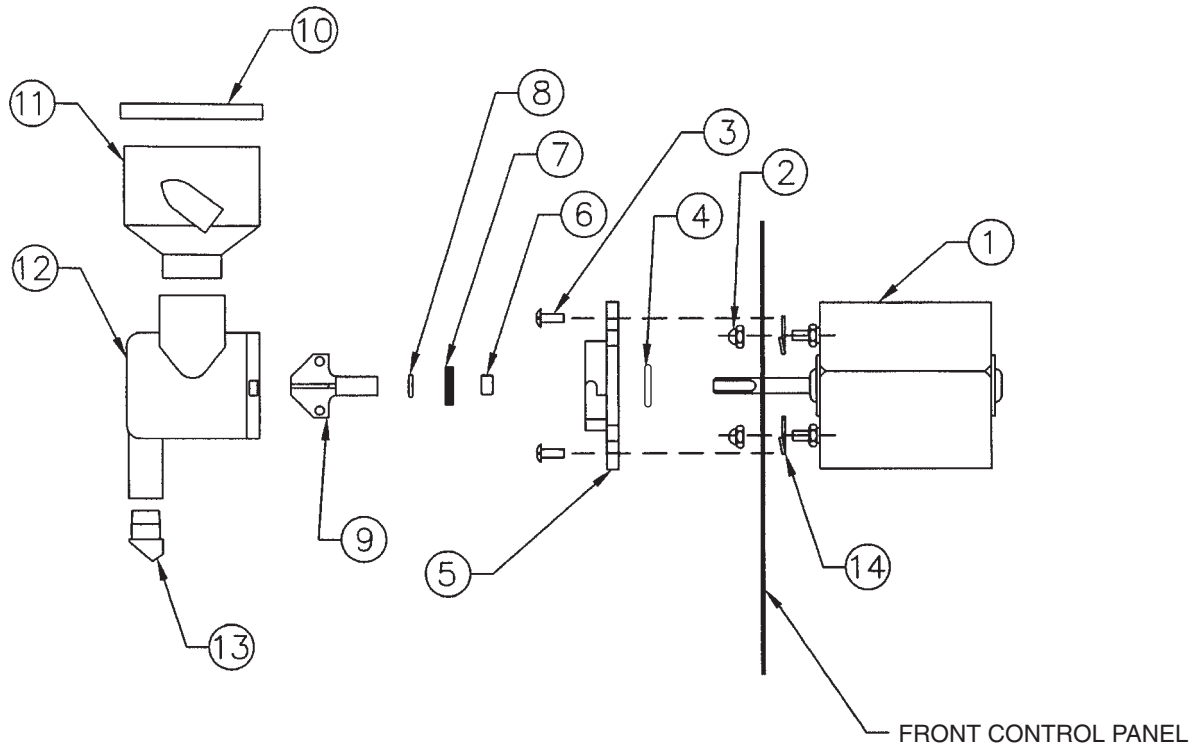

ITEM NUMBER	PART NUMBER	QTY	DESCRIPTION
1	<a href="#">A533-023</a>	1	Whipper Motor
2	601051	2	#8-32 Acorn Nut
3	A539-115	2	#6-32 x 1/4" Truss Head Screw
4	A548-066	1	Washer, Slinger
5	A548-063	1	Base, Self-Locating Whipper
6	<a href="#">A551-058</a>	1	Bearing, 1/4 ID x 5/16 OD x 3/16
7	<a href="#">A544-034</a>	1	Seal, 0.250 x 0.616 x 3/16
8	<a href="#">A544-033</a>	1	O-Ring, 0.250 x 0.070
9	<a href="#">A548-065</a>	1	Blade, 4 Blade Whipper w/Stop
10	<a href="#">A548-067</a>	1	Whipper Cover
11	<a href="#">A548-078</a>	1	Whipper Funnel
12	<a href="#">A548-062</a>	1	Chamber, GM Whipper
13	<a href="#">A548-064</a>	1	Restrictor, Angle Outlet
14	603008	2	#6 Spring Lock Washer

Drawing # [A720-036](#) Rev. B

# Exploded View Pump

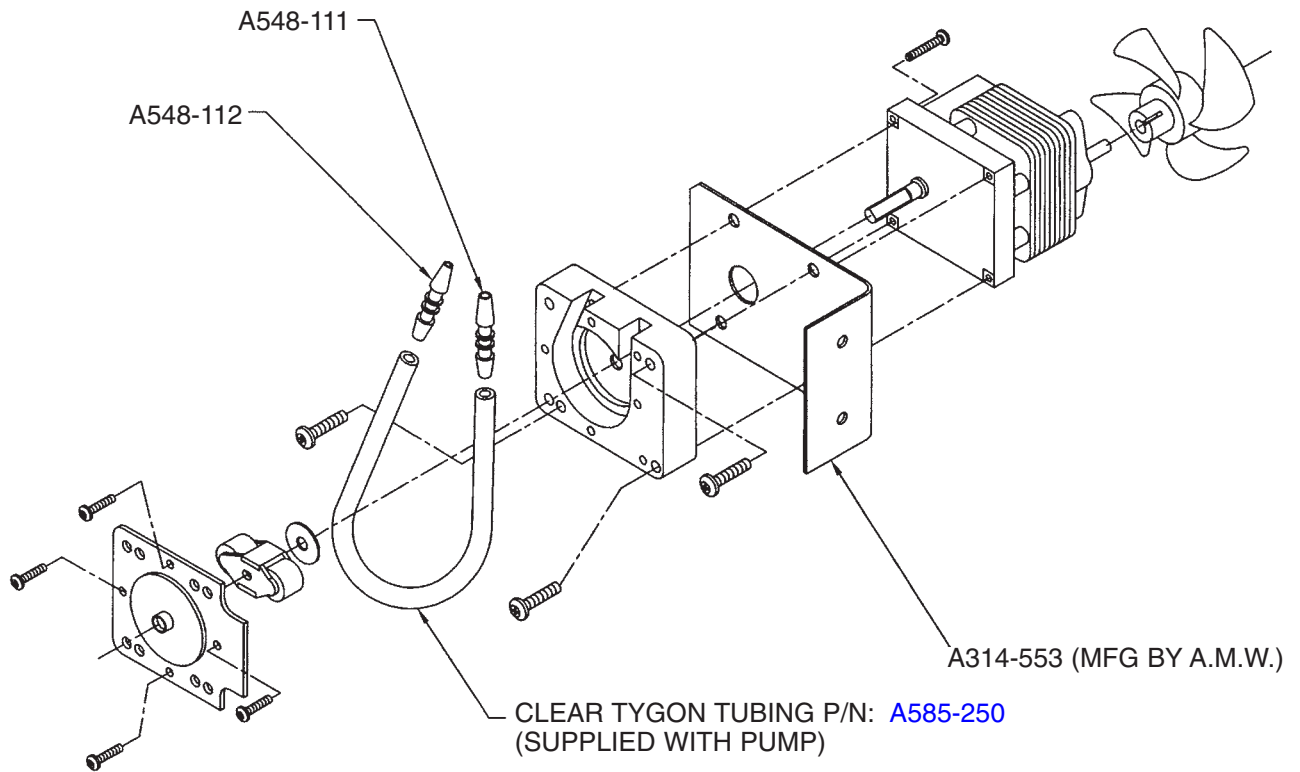

Drawing # A0903-028 Rev. Rel

# Wiring Diagram 120V With Portion Control (Option 5)

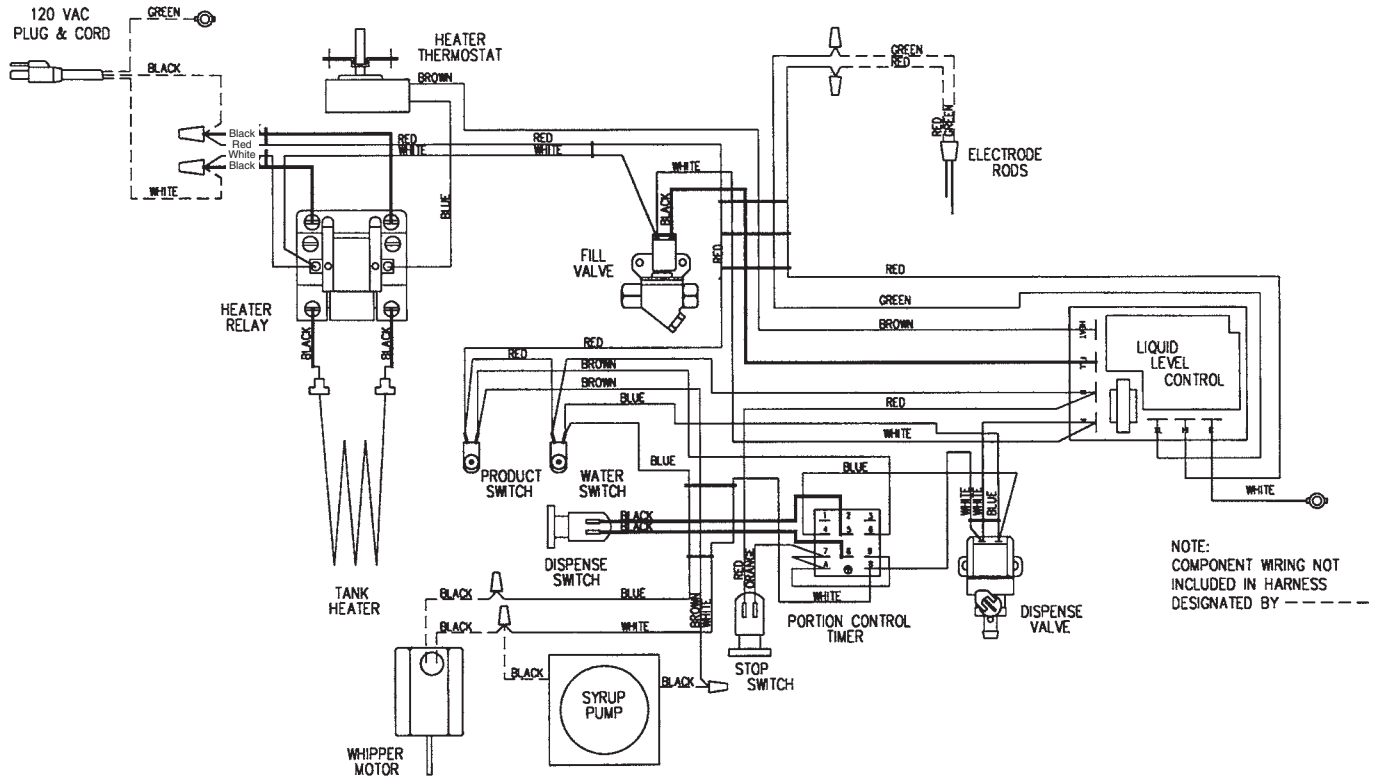

Drawing # 091-329

# HC-2 Parts List

PART NO.	DESCRIPTION
515067	515074 Power Cord
549-006	Liquid Level Control
712-046	Thermostat
712-018	Electrode Assembly
515027	Power Relay 25/30 Amp 115V Coil
535-058	Heater
537-025	Water Fill Valve
537-009	Fill Valve Repair Kit
537-033	Coil for Fill Valve
537-022	0.5GPM Flow Disc for Fill Valve
720-024	Heater Tank Fill Tube-Outlet from Fill Valve
550-089	Wiring Harness
537-109	Dispense Valve
531-009	Dispense Relay Manual
537-016	Repair Kit for GS56 Dispenser Valve
537-030	Adjustable Gate for Dispenser Valve
515001	Product -- Rinse Button
531-029	Dispense Switch
533-040	Hot Chocolate Pump
548-111	Hose Barb Plastic 0.250" x 0.250" Fitting
548-112	Hose Barb Plastic 0.250" x 0.312" Fitting
533-023	Whipper Motor
548-066	Slinger Washer
548-063	Self-Locating Whipper Base
551-058	1/4" ID 5/16" OD x 3/16" Bearing
544-034	0.250" x 0.616" x 0.188" Seal
544-033	0.250" x 0.070" O-Ring
548-065	4 Blade Whipper W/Stop
548-067	Whipper Cover
548-078	Whipper Funnel
548-062	GM Whipper Chamber
548-064	Angle Outlet Restrictor
720-036	Whipper Assembly
585-250	Clear Tygon Tubing (12-1/2")
585-048	Syrup Dispense Tubing (15")
585-049	Water Outlet Tube (3-1/2")
585-045	Water Dispense Tube (6")
585-039	Overflow Tube (1/2" OD x 24")
585-047	Cleaning Tube (1/2" OD x 12")
511005	1-1/8" cp. Hole Plug for Dispense Valve
Optional:	
530-021	K2K-30-661 Portion control Timer NCC
531-033	HC Red Stop Switch Button

