



GRINDMASTER®

Operator Manual

PrecisionBrew™ Coffee Brewers



**Model shown:
PBC-2A2**



Activate your warranty now at
<http://gmcw.com/warranty-registration>



Table of Contents

Safety Information.....	2	Cleaning.....	10
Installation.....	4	Maintenance	11
Start up.....	5	Special Control Functions	12
Operation	6	Troubleshooting Guide.....	13
Adjustments	6	Thermistor Chart	20
Control Features.....	7	Parts Diagram and List.....	20
Air-Heated Shuttle Lighting ...	8	Wiring Diagram.....	51
Programming	8		

Thank you for purchasing this quality brewer. For your safety and the safety of others, read all warnings and the operator manual before installing or using the product. Properly instruct all operators. Keep training records. For future reference, record serial number here:

Grindmaster-Cecilware

4003 Collins Lane, Louisville, KY 40245 USA
Phone: 502.425.4776 Toll Free: 800.695.4500
Fax: 502.425.4664
Web: gmcw.com Email: info@gmcw.com

Grindmaster-Cecilware provides the industry's BEST warranty. Visit gmcw.com for warranty terms and conditions.



Safety Information

Important Safety Information



This is the safety alert symbol. It is used to alert you to potential personal injury hazards. Obey all safety messages that follow this symbol to avoid possible injury or death.

For your safety and the safety of others, read all warnings and the operator manual before installing or using the product.

DANGER: This term warns the user of imminent hazard that will result in serious injury or death.

WARNING: This term refers to a potential hazard or unsafe practice, which could result in serious injury or death.

CAUTION: This term refers to a potential hazard or unsafe practice, which could result in minor or moderate injury.

NOTICE: This term refers to information that needs special attention or must be fully understood.

WARNING

To reduce risk of electrical shock, do not remove access panels. No user-serviceable parts inside. Repair should be done by authorized service personnel only.

The appliance is not intended for outdoor use.

Do not clean with pressurized water, pressure washer, spray nozzle, or use in an area where pressurized cleaning water may be used. This appliance is IP20 rated, and shall not be cleaned with pressurized water.

Cleaning and maintenance shall be made only by properly trained persons with supervision.

Do not remove shuttle or basket while product is brewing.

This appliance is not intended for use by persons with reduced physical, sensory, or mental capabilities, or lack of experience and knowledge, unless they have been given supervision or instruction concerning use of the appliance by a person responsible for their safety.

Children should be supervised to ensure that they do not play with the appliance.

Do not alter or deform the power cord or plug in any way! Altering or deforming the plug may cause electrical shock, damage unit, and will void warranty.

To reduce risk of explosion or fire, do not use near combustibles.

Installation of this appliance should be performed by authorized service personnel only. Improper installation could result in electrocution.

This equipment is provided with a power switch located on the back of the machine. The power switch only switches power to the control circuit. Heating elements are not controlled by the power switch and must be considered live at all times unless the branch circuit is disconnected. Disconnect power at branch circuit before servicing.

Electrically ground the chassis.

Never use the ground conductor as a neutral. This could cause electrocution.

Dangerous electric voltages are present near adjustable components. All adjustments should be performed by qualified service personnel only.

Dangerous voltages and hot surfaces are present inside the machine. Maintenance should only be performed by qualified service personnel.

To reduce the risk of electrical shock, unplug the power cord before repairing or replacing any internal components of the unit. Before any attempt to replace a component, be sure to check all electrical connections for proper contact. Only a qualified service technician should perform electrical and mechanical adjustments or repairs.

Do not place any potentially flammable materials on or near brewer or server base at any time.

⚠ CAUTION

For safe and proper operation, the appliance must be placed in a stable, vertical position.

To reduce risk of serious burns or scalding, do not place hand or other body parts under dispenser or container while product is brewing.

Always unplug unit or disconnect from power supply before servicing.

Hot liquid in brew basket could cause burns. Remove with care.

Warmers and surfaces are hot and can cause burns.

Do not transport brewer without draining water tank(s) first.

Water used for brewing coffee is very hot. Use caution when brewing, pouring, or transporting coffee. Accidental spills may result in severe burns.

Always confirm that the coffee grind profile and Brew Selection settings allow for safe operation without overflowing the brew basket and allow for safe draining of the brew basket after the end of the brew cycle.

Brew basket contains very hot water until the drip is completed. Early removal of a dripping basket could result in burns.

Hot liquids and surfaces are present in this equipment. To avoid burns, use caution when cleaning. Rinse hot parts with cold water before cleaning. Use gloves or a heavy cloth when removing hot parts from brewer.

Water in tank is very hot. Draining of tank should be performed by a qualified service technician. Use caution when draining tank. Accidental spills may result in severe burns.

NOTICE

Use only on a circuit that is properly protected and capable of providing adequate power.

Follow national and local electrical codes.

Do not use extension cord.

This equipment must be installed in compliance with applicable Federal, State and/or Local plumbing codes having jurisdiction. This product requires an approved backflow prevention water device, such as a double check valve, to be installed between the machine and the water supply.

The person installing this appliance is responsible for ensuring that electric and water connections meet the requirements of the national electric code, national plumbing code, and any local ordinances. Incoming pressure should be greater than 30 psi and not more than 80 psi (207-552 KPa).

Double brewers only are provided with dual independent heating tanks. The L1 leg of single phase double brewers is routed through a circuit breaker to prevent the possibility of overloading the branch circuit in the event of both heating elements activate at the same time.

Model	Item No.	Description
PBC-1A2	1004-001	Coffee brewer, single virtual sightglass, air heated shuttle
PBC-2A2	1004-003	Coffee brewer, double virtual sightglass, air heated shuttle
PBC-1W2	1004-002	Coffee brewer, single sightglass, warmer shuttle
PBC-2W2	1004-004	Coffee brewer, double sightglass, warmer shuttle
PBC-1V2	1004-005	Coffee brewer, single, vacuum shuttle without stand
PBC-2V2	1004-006	Coffee brewer, double vacuum shuttle without stand
PBC-1VS2	1004-007	Coffee brewer, single vacuum shuttle with stand
PBC-2VS2	1004-008	Coffee brewer, double vacuum shuttle with stand

Model Acronym Key			
PBC = PrecisionBrew™ Coffee	-1 = One brew head	A = Air heated shuttle	1 = 120 volt (corded)
	-2 = Two brew heads	W = Warmer heated shuttle	2 = 240 volt (field wired)
		V = Vacuum server w/o stand	3 = 240 volt 3 phase (field wired)
		VS = Vacuum server with stand	
RAS = Remote Air warmer stand	1 = 120 volt		
RWS = Remote warmer stand	2 = 240 volt		

Installation

Unpacking Instructions

Carefully unpack the machine and inspect immediately for shipping damage. The packaging may contain unattached parts. Your machine was shipped in a carton designed to give it maximum protection in normal handling. It was thoroughly inspected before leaving the factory. In case of damage, contact the shipper, not Grindmaster-Cecilware.

NOTICE: The person installing this appliance is responsible for ensuring that electric and water connections meet the requirements of the national electric code, national plumbing code, and any local ordinances.

The electrical input connections can be made from either the bottom conduit hole or the back panel conduit hole. Plug the unused hole with the hole plug provided.

The water connection is on the back of the machine. Use only the swivel fitting provided which matches the inlet valve threaded flare fitting.

Mechanical Installation

NOTICE: This brewer should be installed by a knowledgeable and experienced commercial equipment installer.

1. Inspect unit to see if any damage occurred in shipment.
2. Remove the brewer from the packing material and attach its legs.
3. Position the brewer on a strong, stable table or counter, at least 2" away from walls or other appliances.
4. With bubble level, check to see that the brewer is level on countertop. Check the level front to back and side to side. Adjust the legs to the correct level.

Water Hook-up

NOTICE: This equipment must be installed in compliance with applicable Federal, State and/or Local plumbing codes having jurisdiction. This product requires an approved backflow prevention water device, such as a double check valve, to be installed between the machine and the water supply. Incoming pressure should be greater than 30 psi and not more than 80 psi (207-552 KPa).

Note: To prevent excessive pressure drop through water line, use the shortest length water line which will allow for moving the machine on the counter for servicing operations. Excessive length of water line will reduce the flow of water to the machine.

1. The water line enters on the rear of the brewer. Use the right hand opening for water.
2. Use 1/4" copper or flexible water line to prevent strain. Do not use low temperature plastic tubing. The connection to the fill valve is 1/4" flare.
3. Prior to installing the brewer, flush out the water line by running approximately 1 gal. (4L) of water into a pail. This will ensure no sediment from a new installation can get in the brewer.
4. Water line pressure must be from 30 to 80 psi (207-552 kPa).
5. Hot (up to 140°F / 60°C) or cold water may be used. Hot water offers faster recovery between brews.
6. Make sure brewer is unplugged. Connect the water line to the brewer with the hose connector.
7. Install a shut-off valve near the brewer.
8. Installing a filtering system can improve the taste of brewed coffee and extend the life of the brewer. If your water has high calcium (lime), chlorine, or iron content, this is especially important. The filter should be the lime inhibiting type if cold water is used. Contact your local water treatment professional regarding the type of filter you should use based on water quality and volume of water used.

Electrical Hook-up and Start-up Procedure

⚠ WARNING: ELECTRIC SHOCK HAZARD!

Installation of this appliance should be performed by authorized service personnel only. Improper installation could result in electrocution.

⚠ WARNING: ELECTRIC SHOCK HAZARD!

This equipment is provided with a power switch located on the back of the machine. The power switch only switches power to the control circuit. Heating elements are not controlled by the power switch and must be considered live at all times unless the branch circuit is disconnected.

NOTICE: This equipment must be installed in compliance with applicable Federal, State and/or Local electrical codes having jurisdiction. Do not use extension cords. Make sure that the outlet the brewer plugs into is grounded.

The brewer is designed to operate at the specified voltage on the nameplate. If the voltage is too low, the solenoid valves may or may not work or longer recovery time will be experienced. The brewer may be permanently damaged if the voltage is too high.

1. The electric ratings for your brewer are printed on its nameplate.
2. The brewer should be connected to its own circuit

with a fused disconnect switch or a circuit breaker near the brewer.

Important: Means shall be provided to ensure all pole disconnection from the supply. Such means shall be one of the following: a supply cord fitted with plug, or a switch that is directly connected to the supply terminals and has a contact separation of at least 1/8" (3mm) in each pole.

3. Attach the appropriately sized cord to the brewer with a cord grip for the 3/4" conduit (1-1/8" diameter) electric input opening. The cord may enter through the rear or bottom on the left side of the brewer. Use an oil resistant cord such as type SO, SOO, SAO, STOO, SEO, SJO, SJOO, SJTO, SJTOO, SJEO, HSO, HSOO, HSJO, or HSJOO. Alternatively, flexible conduit and type THHN wires may be used. Use only copper conductors.
4. All models except for cord provided models are considered Field Wired. Standard connection is 1 Phase 2 wire + ground. No neutral is needed except for units rated 120 volts. Heating elements and the universal power supply are powered directly from line voltage.

NOTICE: Double brewers only are provided with dual independent heating tanks. The L1 leg of single phase double brewers is routed through a circuit breaker to prevent the possibility of overloading the branch circuit in the event of both heating elements activate at the same time.

The universal power supply provides 24vdc to all control components (solenoids, lights, valves, motors, etc.). The chassis must be grounded. A ground connection is provided next to the terminal block.

⚠ WARNING: ELECTROCUTION HAZARD!

This appliance is IP20 rated, and shall not be cleaned with pressurized water.

⚠ WARNING: ELECTROCUTION HAZARD!

Never use the ground conductor as a neutral. This could cause electrocution.

Start up

⚠ WARNING: ELECTRIC SHOCK HAZARD

This machine is equipped with a power switch on the back of the machine which disconnects the low voltage power supply circuits only. Heating circuits are always powered on when the branch circuit is on.

Disconnect power at branch circuit before servicing.

1. Flip power supply to machine "ON" at the branch supply disconnect. Then flip power switch located on the back of the machine to the "ON" position and allow the water tank to fill. The display on the front should illuminate and machine may make a subtle hissing sound while filling.

Note: A watchdog circuit monitors the fill valve "ON" time. If the "ON" time exceeds 3.5 minutes continuously, the brewer will display message "ER1" and cease operation. Normal initial fill time on some models exceeds 3.5 minutes. Turn off power to brewer and turn back on; this will reset the controller and allow brewer to complete filling.

2. Once the brewer is full, it will take 15 to 60 minutes to heat, depending on model, input voltage, starting water temperature, and number of brew heads.
3. Insert the brew basket(s) and place a shuttle under the basket(s). Brew at least one batch from each side. Check the level in the container to be sure the brew volume is correct. Remember that when using

coffee, the level will be lower. Do this for all batch sizes. The water must be hot to check the levels. If adjustments are needed, see the **Adjustments** section of this manual.

⚠ CAUTION: HOT LIQUID HAZARD

Do not transport brewer without draining water tank(s) first.

Operation

▲ CAUTION: HOT LIQUID HAZARD

Water used for brewing coffee is very hot. Use caution when brewing, pouring, or transporting coffee. Accidental spills may result in severe burns.

1. Insert a 14" X 6" Grindmaster coffee filter into the brew basket.
2. Pour the proper amount of fresh coffee grounds into the brew basket and level by gently shaking. Slide the brew basket into the brew basket rails and select batch size. Follow corporate recommendations for amount of coffee and grind. A full shuttle is 1.5 gallons (5.7L). A full vacuum shuttle is 1.6 gallons (6.0L).
3. Place an empty server under the brew basket. Turn on the warmer if available. If the shuttle is not warm, allow the warmer to heat the shuttle. A short brew of only water will speed this. A cold shuttle will significantly lower the temperature of the brewed coffee.
4. The brewer will only brew if the minimum brew temperature setting has been reached. See "water temp" icon in the tools setting and adjust minimum temperature setting as desired. Note: tank temperature is sensed at the bottom of the hot water tank so there is usually a reserve of hot water available for proper brewing after initial heatup.
5. Brewer will not brew when:
 - a) BREW TEMPERATURE TOO LOW - wait until tank is heated to temperature setpoint. Note: each brew head has its own heating tank which is controlled independently. On double head brewers, the right side tank receives preference to full power heating; followed by the left side tank.
 - b) BREW BASKET NOT DETECTED.

c) BREW BASKET HAS NOT BEEN REMOVED SINCE LAST BREW - remove basket, empty previously brewed grounds and grind a new batch into brew basket.

d) SERVER NOT IN PLACE - place appropriate Server in place under brew basket until presence switch is activated.

6. Press the brew arrow on the LCD display for the appropriate brew head and the LCD display will lead you through the above steps to initiate the brew sequence.

▲ CAUTION: HOT LIQUID HAZARD

Always confirm that the coffee grind profile and Brew Selection settings allow for safe operation without overflowing the brew basket and allow for safe draining of the brew basket after the end of the brew cycle.

7. During the brew cycle, a countdown timer will indicate the remaining time left for the brew cycle. Following the BREW cycle will be a countdown of DRIPPING time which shows the time remaining until the brew basket lock will release. Discard the grounds and filter only after visible dripping stops and the basket lock plunger has released. Always use caution when removing the brew basket to prevent potential splashing of hot water which could be trapped from a clogged brew basket outlet.

▲ CAUTION: HOT LIQUID HAZARD

Brew basket contains very hot water until the drip is completed. Early removal of a dripping basket could result in burns.

8. The shuttle may be placed on remote warming stations. Use caution when moving a full shuttle.

Adjustments

▲ WARNING: ELECTRIC SHOCK HAZARD! Dangerous electric voltages are present near adjustable components. All adjustments should be performed by qualified service personnel only.

All adjustments to machine are accessible through the front display. Refer to specifics below and the Programming Routine section. All values are preset at the factory and may vary brewer to brewer.

Temperature Adjustment

Tank temperature can be adjusted from 170°F – 205°F (77°C – 96°C) through the front display. See **Programming** section for procedure.

This brewer can be set for maximum water temperature of 205°F (96°C). The boiling point of water is lower as altitude increases. The setpoint temperature of the brewer should be maintained below the boiling point at a given elevation. Refer to the chart below for recommended maximum setpoint for given altitudes.

Adjustments (continued)

Altitude		Approximate Boiling Point		Recommended Max. Temperature	
(ft)	(m)	°F	°C	°F	°C
0	0	212	100	205	96.1
500	152	211.1	99.5	204	95.6
1000	305	210.2	99.0	203	95.0
1500	457	209.3	98.5	202	94.4
2000	610	208.4	98.0	201	93.9
2500	762	207.5	97.5	200	93.3
3000	914	206.6	97.0	199	92.8
3500	1067	205.7	96.5	199	92.8
4000	1219	204.8	96.0	198	92.2
4500	1372	203.9	95.5	197	91.7
5000	1524	203	95.0	196	91.1
5500	1676	202	94.4	195	90.6
6000	1829	201.1	93.9	194	90.0
6500	1981	200.2	93.4	193	89.4
7000	2134	199.3	92.9	192	88.9
7500	2286	198.3	92.4	191	88.3

Control Features

Pre-infusion: Controls the initial coffee grounds wetting and the first dwell time after the initial wetting. Pulse brews are the series of pulses after the Pre-infusion process.

Brew Countdown Timer: After the start of a brew the LCD display will countdown the remaining time left in the brew process. The countdown will include all OFF periods programmed in the Pre-infusion and the pulses.

Energy Savings Mode: If enabled, when the brewer is idle for a selectable time of 1-12 hours, this feature will allow the water tank to lower its holding temperature to 60°C (140°F). The display will scroll through background images while in this mode. To exit energy savings mode, press the display and the unit will start reheating to brewing temperature.

Air-Heated Shuttle Lighting



Backlighting Lighting Color sequences:

If freshness timer setting is “ON”:

- Red while brewing
- Solid Green backlighting: After brewing for 80% of freshness timer setting
- Solid Yellow backlighting: Final 20% remaining in the freshness timer
- Solid Red backlighting: Freshness timer elapsed

If freshness timer setting is “OFF”:

Backlighting randomly cycles colors as long as the shuttle is on the brewer while heater is “ON”

Error states:

Flashing Blue: Fan not spinning

Flashing Red: Air heater over-temp

Flashing Green: Air temperature thermistor out of range

Programming

Default brewing interface passcode is 1234.

Default service menu passcode is 4003.

USB programming is one of the ways a user can change the default recipes. After the recipes are updated using the touch screen user interface, the programs can be uploaded to a USB (Universal Serial Bus) drive by means of the USB port on the front top of the brewer above the center of the screen. The uploaded USB drive then can be used to transfer the recipes and settings to other machines reducing the setup time of future unit. The USB transfer ability allows for standardized programs between locations and simplifies service technician's work.

The USB drive must have a type-A connection, have USB 2.0 capability, and a minimal 2 GB of storage space.



SOFTWARE INFORMATION TRANSFER:

To upload or download settings, recipes, or images: Select USB icon in the LCD display.

Default passcode & passcode setup: Select Passcode icon under Settings on LCD display.

Programming (continued)

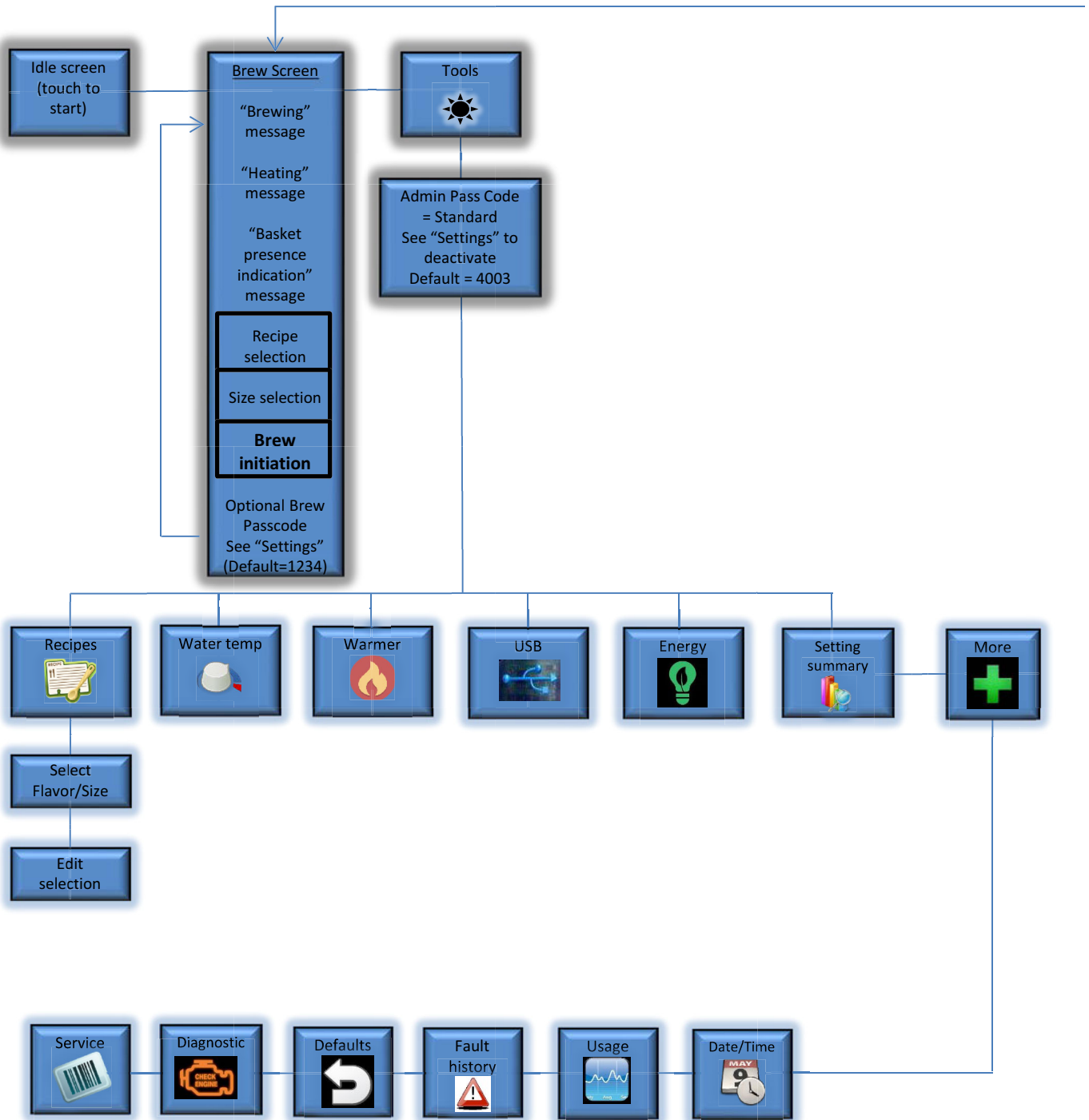

Cleaning

▲ CAUTION: BURN HAZARD

Hot liquids and surfaces are present in this equipment. To avoid burns, use caution when cleaning. Rinse hot parts with cold water before cleaning. Use gloves or a heavy cloth when removing hot parts from brewer.

NOTICE: All sanitizing agents in the food zone must comply with US Food and Drug Administration regulation 21 CFR 178.1010 "Sanitizing Solutions" and US Environmental Protection Agency 40 CFR 18.940 "Tolerance exemptions for active and inert ingredients for use in antimicrobial formulations (Food-contact surface sanitizing solutions)". Sanitize all food dispensing units periodically. All parts to be sanitized must be cleaned first. Cleaning and sanitizing frequency must follow state and local health department regulations.

After Each Brew:

1. Dispose of grounds and rinse brew basket.
2. Rinse shuttles with hot water and empty completely.
3. Fill shuttles with hot water.
4. Open shuttles and empty contents completely by opening the faucet.

Every Day:

1. Wash brew basket with warm soapy water. The wire basket is removable to aid cleaning.
2. Remove spray head(s) located above brew basket(s), using gloves or a heavy towel. Wash off coffee oils and clean any plugged holes.
3. Clean shuttles with warm soapy water and a soft towel.
4. Wipe exterior of brewer with a damp cloth. Do not use abrasives which will scratch surface.
6. If shuttles are to be left on the warmer all night, fill with water to avoid coffee oil burn-in.

Weekly or Bi-Weekly, Depending on Use:

1. Fill shuttles with one gallon, 2/3 full, of hot water.
2. Pour the recommended concentration of urn cleaner into the shuttle liners (Excessive amounts of cleaner will attack the stainless steel).
3. Gently wipe the plastic liner with a soft cloth soaked in urn cleaner to remove coffee residues. Do not use anything which will scratch the plastic shuttle liner. A good urn cleaner such as "Urn Clean" will remove coffee oils and mineral deposits from both plastic and stainless steel without harsh scrubbing.
4. Remove the knurled nut at the top of the gauge glass and clean the glass with a small bottle brush.
5. Pour out the contents of the shuttle.
6. Remove the handle assembly of the shuttle faucet by unscrewing the plastic bonnet nut.
7. Gently wash the faucet seat cup with a soft cloth and warm soapy water.

8. Wash the faucet shank with a bottle brush.
9. Clean the warmer and bottom of shuttle surfaces. These surfaces must be clean for proper heat transfer.
10. Polish the exterior of the brewer with stainless steel cleaner. Use the appropriate cleaner for brass, copper, or vinyl if these optional finishes are provided.

Cleaning and Sanitizing Vacuum Shuttle and

Stand:

1. Cleaning and sanitizing lid assembly:
 - a) Remove lid from unit, fully submerge it in cleaning solution. Using a clean cloth, wipe the unit thoroughly.
 - b) Using supplied brush, clean mixing tube thoroughly.
 - c) Rinse with clean water.
 - d) Submerge in sanitizing solution for 5 minutes then air dry completely.
2. Cleaning and sanitizing body assembly:
 - a) Remove unit from the base. (Only when using 2503-002.)
 - b) Completely fill the unit with cleaning solution. Using a clean cloth, wipe the unit thoroughly.
 - c) Rinse unit thoroughly with fresh water.
 - d) Remove faucet, shank, and sight gauge from unit and place in cleaning solution.
 - e) Open lid on the bottom of the unit and remove silicone tube (tank to faucet tube) and place in cleaning solution for cleaning.
 - f) Reassemble unit.
 - g) Fully fill unit with sanitizing solution for 5 minutes and drain through fully opened faucet.
 - h) Wipe outside of the unit with a clean cloth moistened with sanitizing solution.
 - i) Place unit on rack upside down to thoroughly air-dry.
3. Cleaning stand assembly and tray:
 - a) Remove tray and tray top and place in cleaning solution. Using a clean cloth, clean tray and tray top thoroughly.
 - b) Wipe outside of the stand with a clean cloth moistened with sanitizing solution.
 - c) Place parts on rack to thoroughly air-dry.
4. Cleaning the faucet assembly and silicone tube:
 - a) Using supplied brush, clean silicone tube, sight gauge tube, and shank assembly.
 - b) Rinse parts and place in sanitizing solution for 5 minutes, remove, and air dry.
 - c) Remove top from faucet and use brush to clean inside, rinse, and place in sanitizing solution for 5 minutes.
 - d) Remove and air dry.
5. When all pieces are completely dry reassemble for use.

Maintenance

▲ WARNING: ELECTRICAL AND BURN HAZARD

Dangerous voltages and hot surfaces are present inside the machine. Maintenance should only be performed by qualified service personnel.

▲ CAUTION: BURN HAZARD

Water in tank is very hot. Draining of tank should be performed by a qualified service technician. Use caution when draining tank. Accidental spills may result in severe burns.

To Drain the Water Tank

NOTICE: Always empty tank(s) before shipping.

NOTE: Brewer may contain over 6 gallons (23L) of hot water.

1. Prepare a heat resistant container to drain tank water into.
2. Disconnect power to brewer.
3. Remove the front access panel.
4. Pinch or clamp the silicone drain hose and remove hose plug.
5. Place hose over drain and release clamp.
6. Allow the tank to drain completely.

NOTE: It may be necessary to pinch the hose and stop the water before container is full. Carefully reinstall hose plug, then empty container. Repeat steps 4-6 completely to drain tank.

Remove Brew Valve

Remove Brew or Bypass valve (Note: the dispense valves incorporate a ¼ turn bayonet style mounting; use care when handling):

1. Disconnect power to machine.
2. Using an appropriate vessel to hold hot water, safely drain the water tank to a level below the solenoid level by operating the manual hot water tap until the water tap does not flow. This will be the indication that the tank is drained below the level of the solenoid valves.
3. Remove top cover.
4. Gently disconnect the electrical leads from the valve coil.
5. Gently remove the Silicone rubber tube from the valve inlet.
6. Gently twist the valve clockwise ¼ turn and remove the valve.

To Remove the Heater

1. Disconnect power and remove top cover of brewer.
2. Disconnect wire leads to heater, thermistor, level probe, and ground wires.
3. Remove tank cover by loosening retaining nuts. Cover is lifted up with heater attached. Heater is then removed.
4. Replace heater with sealing washers in same configuration. When tightening nuts, hold element so it does not twist.
5. Replace tank cover, ensuring O-ring seal is good.
6. Replace heater wires. Be sure all electrical connections are secure. Ensure silicone rubber insulator sleeves are re-positioned to protect the heater terminals.
7. Replace top cover of brewer and connect power cord to outlet.

Removing water inlet valve:

1. Turn off water supply to inlet valve.
2. Disconnect swivel fitting from inlet valve.
3. Remove front splash panel.
4. Using an appropriate container, drain the hot water tank completely.
5. Disconnect wires from inlet valve.
6. Remove hose clamp from silicone rubber tube at the inlet valve.
7. Remove silicone rubber tube from valve.
8. Remove (2) valve retaining screws.
9. Remove valve.
10. Installation is reverse order; Note: ensure hose clamp is properly replaced to prevent the possibility of the silicone rubber hose blowing off during a fill sequence.

Special Control Functions

Reset factory defaults:

Select Tools / More / More / Defaults buttons on LCD display

Control schematic

⚠ WARNING: ELECTRICAL AND BURN HAZARD

Dangerous voltages and hot surfaces are present inside the machine. Maintenance should only be performed by qualified service personnel.

Main Control Board description

USB connection used for:

1. Reprogramming software
2. Loading / Saving recipes / settings
3. Loading images

Programming enable switch:

LCD display ribbon cable connection

CR2032 Coin cell battery for real-time clock backup

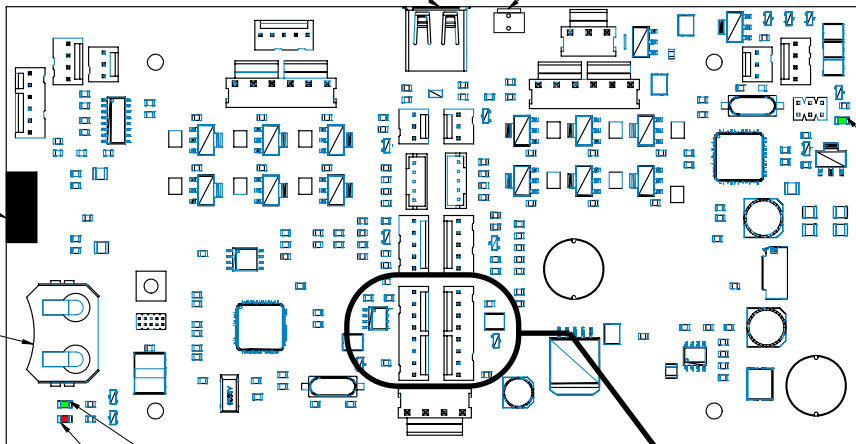

Green LED: Input / Output operation:

1. Blinks green at 1 Hz if OK
2. Solid green or off indicates a malfunction has occurred

Green LED: User Interface processor indicator:

1. Blinks at 1 Hz if operating properly
2. Solid green while programming

Red LED: User Interface processor indicator:

1. Solid RED if an error has occurred
2. Also Solid RED while programming

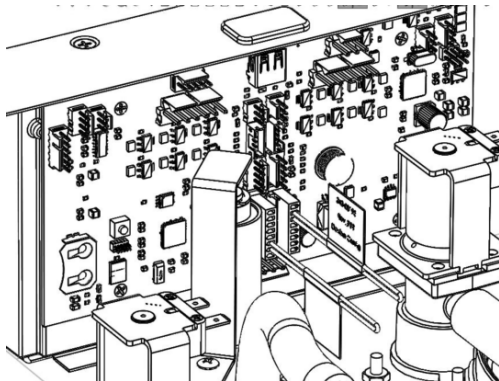

343-00195 Jumper configuration schematic

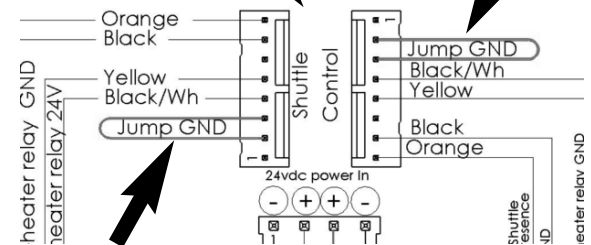

Models with Jumpers included in harness

Note: All Coffee brewers require configuration jumpers applied as shown. Configuration jumpers are provided from the factory either built into the main wiring harness, or as separate jumpers (p/n 343-00195) depending on the model. Ensure these jumpers are replaced if a control board is replaced. If jumpers are not replaced, the machine will default to "Tea brewer" functionality.

Troubleshooting Guide

▲ WARNING: To reduce the risk of electrical shock, unplug the power cord before repairing or replacing any internal components of the unit. Before any attempt to replace a component, be sure to check all electrical connections for proper contact. Only a qualified service technician should perform electrical and mechanical adjustments or repairs.

The following pages are provided to help determine the cause of problems with operation of the brewers and to indicate the appropriate solution for the problems. For each problem, the possible causes should be checked in the order shown until the exact nature of the problem is determined.

The following procedures must be performed by a qualified service technician. Disconnect power to machine before servicing.

Before you call for help, please read the following:

Error Messages				
PROBLEM	POSSIBLE CAUSE	SERVICE CHECK	SOLUTION	
Display does not illuminate	• Branch circuit is disconnected	• Check branch circuit	• Turn on power at branch circuit	
	• Power switch on back of machine is in OFF position	• Check power switch	• Flip power switch up to the ON position	
	• Control circuit breaker has tripped	• Check circuit breaker	• Press plunger on circuit breaker located next to the power switch on the back of the unit	
	• Universal power supply is faulty	• Check universal power supply input and output voltage Input voltage should read AC line voltage DC output should read 24vdc	• Replace power supply if needed	
	• Power supply connections are disconnected	• Check power supply connections	• Ensure connections are made at both the power supply and the controller input	
	• Control to LCD display ribbon cable connection is faulty	• Check ribbon cable connections to both display and control board	• ** Re-seat ribbon cable connections as shown on page 18. (note: ribbon cable provides all power and communication to display)	
	• Faulty display	• Perform all other checks first	• Replace display only if all other checks do not resolve the issue	

Troubleshooting Guide (continued)

▲ WARNING: To reduce the risk of electrical shock, unplug the power cord before repairing or replacing any internal components of the unit. Before any attempt to replace a component, be sure to check all electrical connections for proper contact. Only a qualified service technician should perform electrical and mechanical adjustments or repairs.

Brewing problems			
PROBLEM	POSSIBLE CAUSE	SERVICE CHECK	SOLUTION
Display shows Tea images	• Coffee configuration jumpers are not on control	• Check for configuration jumpers	• Refer to page 11 sketch for information
LCD display indicates “no brew basket detected” when basket is installed	• Brew basket is rotated to left or right instead of straight in	• Check brew basket orientation	• Brew basket must be installed straight to allow brew basket detection circuit to operate
Water distribution over coffee bed is not uniform	• Magnetic spray head is missing	• Remove brew basket and observe if spray head is intact	• Replace spray head if missing
	• Spray head is dirty or has mineral buildup	• Remove magnetic spray head and check for clogged spray pattern holes	• Clean or delime the spray head and replace
Filling / water leakage problems			
PROBLEM	POSSIBLE CAUSE	SERVICE CHECK	SOLUTION
Water dripping from spray head when power is off	• Weeping water inlet valve	• Check for water weeping from overflow opening on spray dome (not brew valve)	• Replace valve (non-serviceable item)
	• Weeping brew or bypass valves	• Observe for leakage at dispense valves	• Remove brew basket and spray head and look for water weeping from brew valve outlets on bottom of spray dome replace valves if needed
	• Residual water in spray head	• Check spray head for clogging	• Clean spray head to remove any coffee or lime buildup which may restrict the spray head
Overfilling water tank only when power is on	• Water level probe is coated with lime	• Check level probe	• Carefully remove level probe from retaining grommet and remove any deposits
	• Level probe electrical connection is faulty	• Check level probe connections	• Ensure level probe connections are good at the level probe, tank ground, and control board connections

Troubleshooting Guide (continued)

▲ WARNING: To reduce the risk of electrical shock, unplug the power cord before repairing or replacing any internal components of the unit. Before any attempt to replace a component, be sure to check all electrical connections for proper contact. Only a qualified service technician should perform electrical and mechanical adjustments or repairs.

Filling / water leakage problems (continued)

PROBLEM	POSSIBLE CAUSE	SERVICE CHECK	SOLUTION
Water tank does not refill	• Power is not supplied to the machine	• Check power connections	• Ensure the branch circuit is on, the power switch on the back of the machine is on, and the circuit breaker next to the power switch is not tripped
	• Water supply is turned off to machine	• Verify water supply is on and active	• Check water supply to machine is turned on if necessary, verify that water supply is actually on by removing the water inlet connection to verify flow
	• Faulty fill valve	• Check if fill valve electrical input is ok • Check electrical connections at both fill valve and control board	• Replace valve if valve is receiving 24vdc input • Correct electrical connections

Heating problems

PROBLEM	POSSIBLE CAUSE	SERVICE CHECK	SOLUTION
Water tank does not heat but display indicates "heating"	• Heater circuit breaker has tripped		Reset circuit breaker on back of machine by pressing plunger
	• Solid state relay connections are faulty	• Check Relay connections	• Ensure Solid State Relay connections are good at control and relay located on bottom of tank (Confirm Polarity is correct)
	• Solid state relay is faulty	• Check DC input voltage input and line voltage output at SSR. Note that SSR has a LED indicator which illuminates when the SSR receives a signal to turn the heater on	• Replace the SSR if the SSR DC input voltage is 3.3 volts and the SSR output voltage is receiving line voltage

Troubleshooting Guide (continued)

▲ WARNING: To reduce the risk of electrical shock, unplug the power cord before repairing or replacing any internal components of the unit. Before any attempt to replace a component, be sure to check all electrical connections for proper contact. Only a qualified service technician should perform electrical and mechanical adjustments or repairs.

Heating problems (continued)

PROBLEM	POSSIBLE CAUSE	SERVICE CHECK	SOLUTION
Water tank does not heat but display indicates "heating" (continued)	• Solid state relay is not secured to bottom of tank properly	• Check to ensure SSR is secured to bottom of tank properly for proper heat sinking to the tank	• Tighten retaining screw snug but not over-tightened
	• Tank water level is too low which is disabling heating circuit	• Check if water level circuit is functioning properly by dispensing water from the hot water tap into an appropriate container	• Resolve water level circuit issue if machine is not refilling properly
	• Faulty heating element	• Check for voltage across heating element	• Replace heating element if needed
	• Hi-limit temperature switch has tripped	• Press reset button on hi-limit switch located on top of the hot water tank	• Tripping of the hi-limit switch indicates a fault condition. Monitor machine to determine root cause of tripping of the hi-limit switch
	• Control board watchdog timer has tripped to protect the machine from filling or heating errors	• Reset power to machine by powering down from power switch on back of machine	• If resetting power resolves the issue, monitor machine to determine root cause. Intermittent loss of water supply (i.e. facility maintenance) can cause nuisance tripping of the watchdog timer
	• Heater terminal screws are loose	• Check heater terminal screws for tightness	• Tighten screws while supporting screw tab to prevent torqueing of the heater cold pin to prevent damage to the heater
	• Faulty control board	• Perform all other checks	• Replace control board only if all other checks are determined OK

Troubleshooting Guide (continued)

⚠ WARNING: To reduce the risk of electrical shock, unplug the power cord before repairing or replacing any internal components of the unit. Before any attempt to replace a component, be sure to check all electrical connections for proper contact. Only a qualified service technician should perform electrical and mechanical adjustments or repairs.

Heating problems (continued)			
PROBLEM	POSSIBLE CAUSE	SERVICE CHECK	SOLUTION
Water tank boils intermittently (steam exits brew basket during heating)	<ul style="list-style-type: none"> Water temperature set point is too high for the operating elevation 	<ul style="list-style-type: none"> Determine operating elevation and compare to the chart below 	<ul style="list-style-type: none"> To prevent boiling, adjust water tank temperature at least 3 degrees below the boiling temperature for the operating elevation (see programming section for adjustment details)
Air heated shuttle is backlit but air heater is not heating	<ul style="list-style-type: none"> Air heater is blocked with debris Air heater fan is faulty or blocked 	<ul style="list-style-type: none"> Inspect fan for proper operation. Observe LCD display for fan failure indication 	<ul style="list-style-type: none"> Clean air heater and reset hi-limit thermostat Replace fan if needed
Brew volume too large or too small	<ul style="list-style-type: none"> Coffee bed absorbs brew volume which results in less volume than actual programmed brew volume Portion size on touchpad was not selected correctly Total dispensed brew volume setting is too high Spray head is clogged Brew valves are clogged with lime deposits 	<ul style="list-style-type: none"> Review programmed time settings for the desired brew volume Check total brew volume setting in programming for the specific recipe which is considered too high Visually inspect the spray head for coffee residue or lime buildup Visually inspect brew valves for signs of debris 	<ul style="list-style-type: none"> Account for coffee bed absorption in dispensed brew volume Adjust settings to desired values Reduce volume setting and confirm the setting is saved to memory Clean if needed Replace or clean valve if needed

Troubleshooting Guide (continued)

▲ WARNING: To reduce the risk of electrical shock, unplug the power cord before repairing or replacing any internal components of the unit. Before any attempt to replace a component, be sure to check all electrical connections for proper contact. Only a qualified service technician should perform electrical and mechanical adjustments or repairs.

PROBLEM	POSSIBLE CAUSE	SERVICE CHECK	SOLUTION
Brew volume is erratic	<ul style="list-style-type: none"> Inlet water pressure is low or erratic during the brew sequence 	<ul style="list-style-type: none"> Check if water flow to machine is restricted or is being affected by other equipment operating from the same line 	<ul style="list-style-type: none"> Correct water supply to ensure water flow rate is sufficient (30-80psi on a minimum ¼" ID water line). Note: Long water lines may provide adequate static pressure but will cause a large pressure drop and restricted flow
Brew cycle will not start	<ul style="list-style-type: none"> Coffee shuttle is not in place Brew basket is not in place Minimum water temperature defined in programming has not been reached 	<ul style="list-style-type: none"> Ensure the proper coffee container is in place and detected Ensure the brew basket is in place and the handle is not off to either side Allow water tank to reach minimum temperature 	<ul style="list-style-type: none"> Install Coffee shuttle on machine in correct position Handle must be installed straight for the presence switch to detect the basket Alter minimum water tank temperature of disable low temp / no brew if desired to avoid delays
Shuttle backlighting is not working	<ul style="list-style-type: none"> Shuttle is not seated on machine 	<ul style="list-style-type: none"> Check shuttle placement 	<ul style="list-style-type: none"> Re-seat shuttle onto shelf
Coffee agitation is not working	<ul style="list-style-type: none"> Mixing pill is missing or misplaced in coffee shuttle Mixing motor is faulty Mixing motor connections are faulty 	<ul style="list-style-type: none"> Inspect inside of shuttle for missing or misplaced mixing pill Inspect agitation motor for rotation by applying 24 vdc to input terminals Inspect motor connections at both the disconnect, and heater control board 	<ul style="list-style-type: none"> Replace mixing pill and ensure mixing pill is centered in the shuttle liner and that it has a good magnetic couple to the drive magnet Replace motor if this test does not activate the motor Re-make the motor electrical connections

Troubleshooting Guide (continued)

⚠ WARNING: To reduce the risk of electrical shock, unplug the power cord before repairing or replacing any internal components of the unit. Before any attempt to replace a component, be sure to check all electrical connections for proper contact. Only a qualified service technician should perform electrical and mechanical adjustments or repairs.

** Ribbon cable connections must be made per the sketch below:

Silver contacts "UP" as shown for Controller

Note: Control ribbon cable latch slides as shown by arrow to open or close

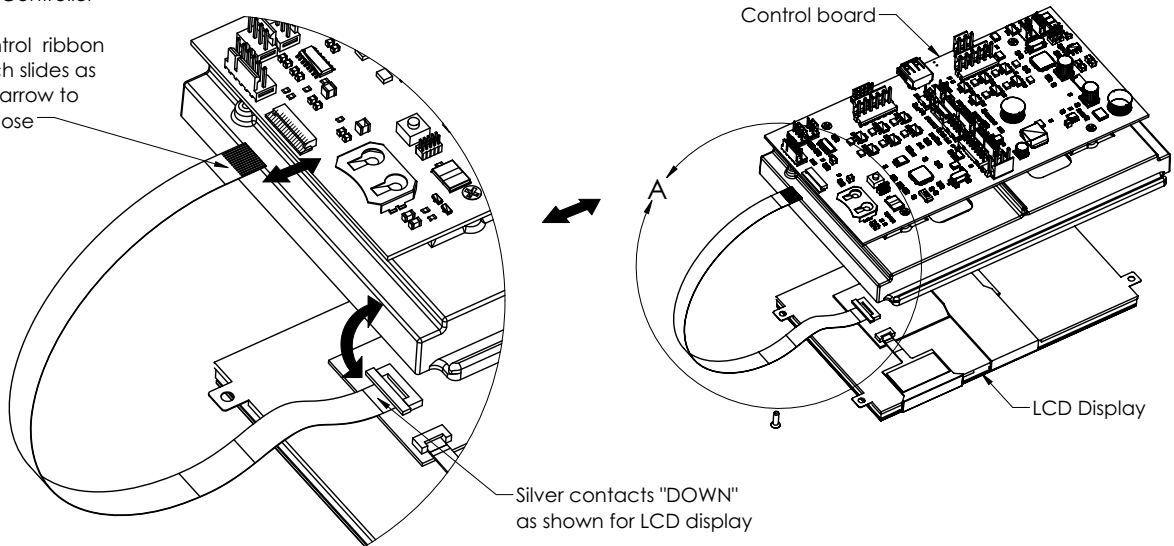

Note: Display ribbon cable latch rotates as shown by arrow to open or close

LCD communication ribbon cable orientation

If you still need help, call Grindmaster-Cecilware Technical Service Department, (502) 425-4776 or (800) 695-4500 (USA & Canada only) (Monday through Friday 8 AM - 6 PM EST). Please have the model and serial number ready so that accurate information can be given.

Prior authorization must be obtained from Grindmaster-Cecilware for all warranty claims.

Grindmaster-Cecilware provides the industry's BEST warranty. Visit our website at gmcw.com for warranty terms and conditions.

Thermistor Chart

Resistance chart showing the ohm value of the thermistor at the appropriate temperature.

THERMISTOR CURVE FOR PART # 61128						
°C	°F	RESISTANCE (OHMS)		°C	°F	RESISTANCE (OHMS)
0	32	16325		60	140	1244
5	41	12697		65	149	1041
10	50	9951		70	158	875
15	59	7856		75	167	740
20	68	6246		80	176	628
25	77	5000		85	185	535
30	86	4028		90	194	458
35	95	3266		95	203	393
40	104	2663		100	212	339
45	113	2185		105	221	294
50	122	1802		110	230	255
55	131	1493				

Parts Diagram and List

Labels

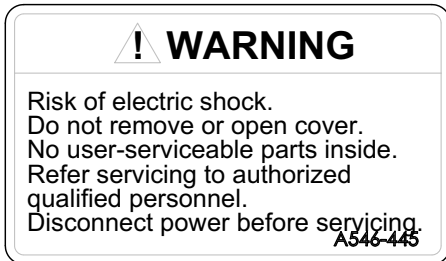

A546-445: Located on the front splash panel and top cover



71949: Located on the brew basket



A546-321: Located on the front splash panel or shuttle support shelf on heated shuttle models



A92572: Located on the coffee server

Parts Diagram and List (continued)

Brew baskets – Plastic and SS

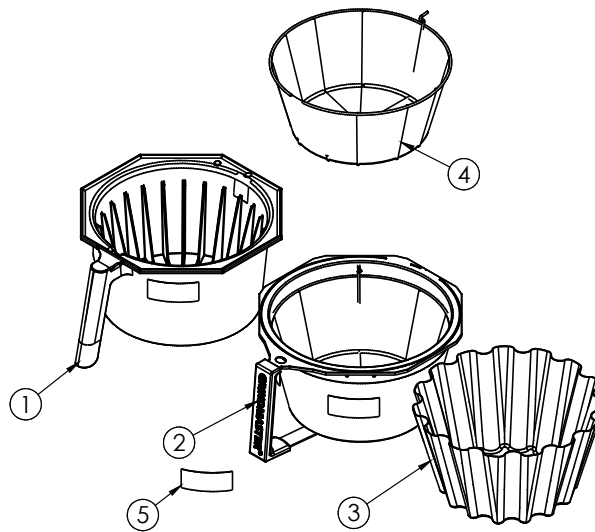

ITEM NO.	PART NUMBER	DESCRIPTION
1	230-00199	Basket, Coffee with warning label
2	230-00173	BREW BASKET, COFFEE, SS
3	ABB2.0WP	Filter papers, 14" X 6"
4	A542074	BB2.0 COLUMBIA WIRE BASKET EPO
5	71949	DECAL, CAUTION BREW BASKET

Parts Diagram and List (continued)

1004-001 Top level panels

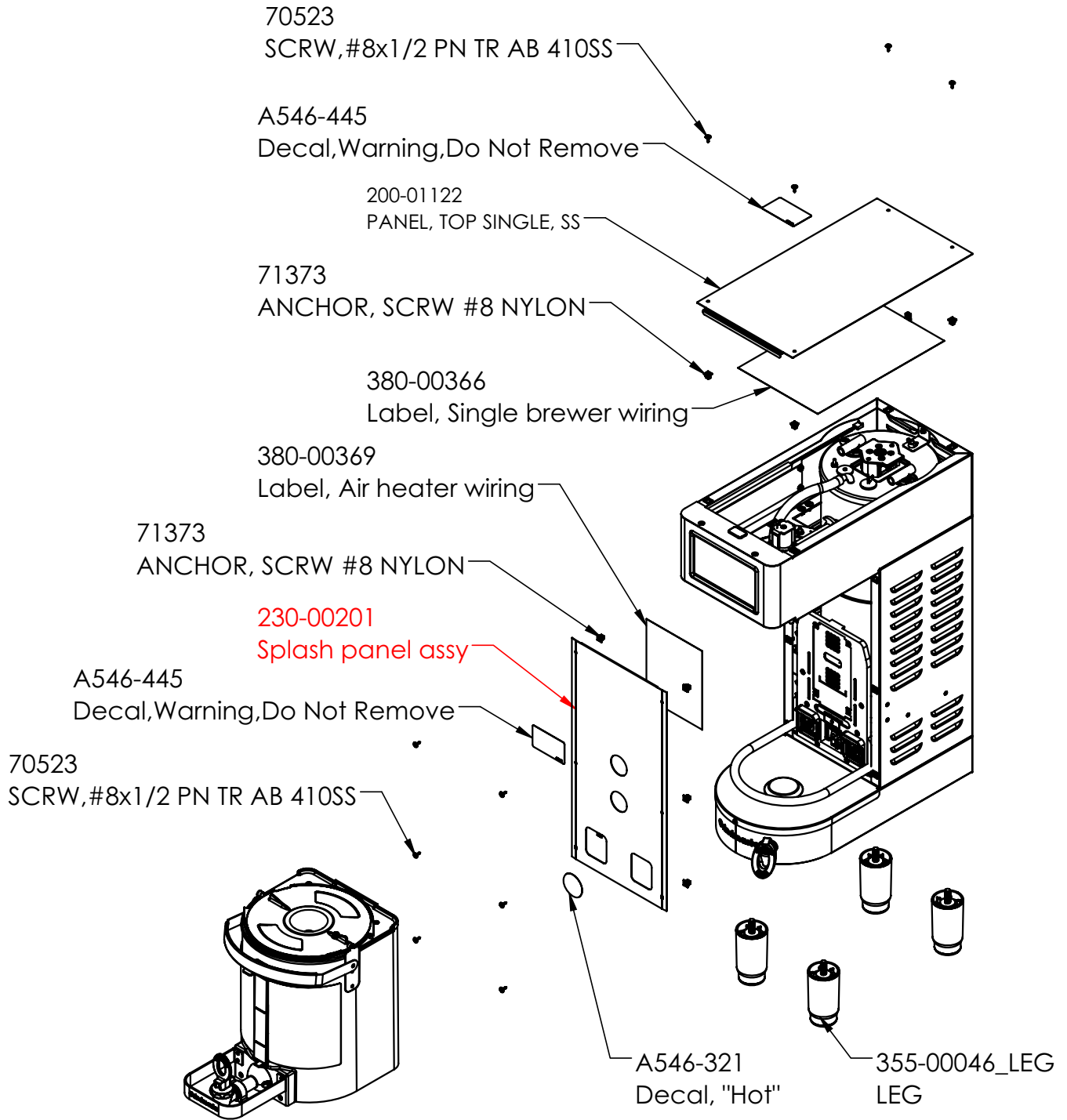

Parts Diagram and List (continued)

1004-002 Top level panels

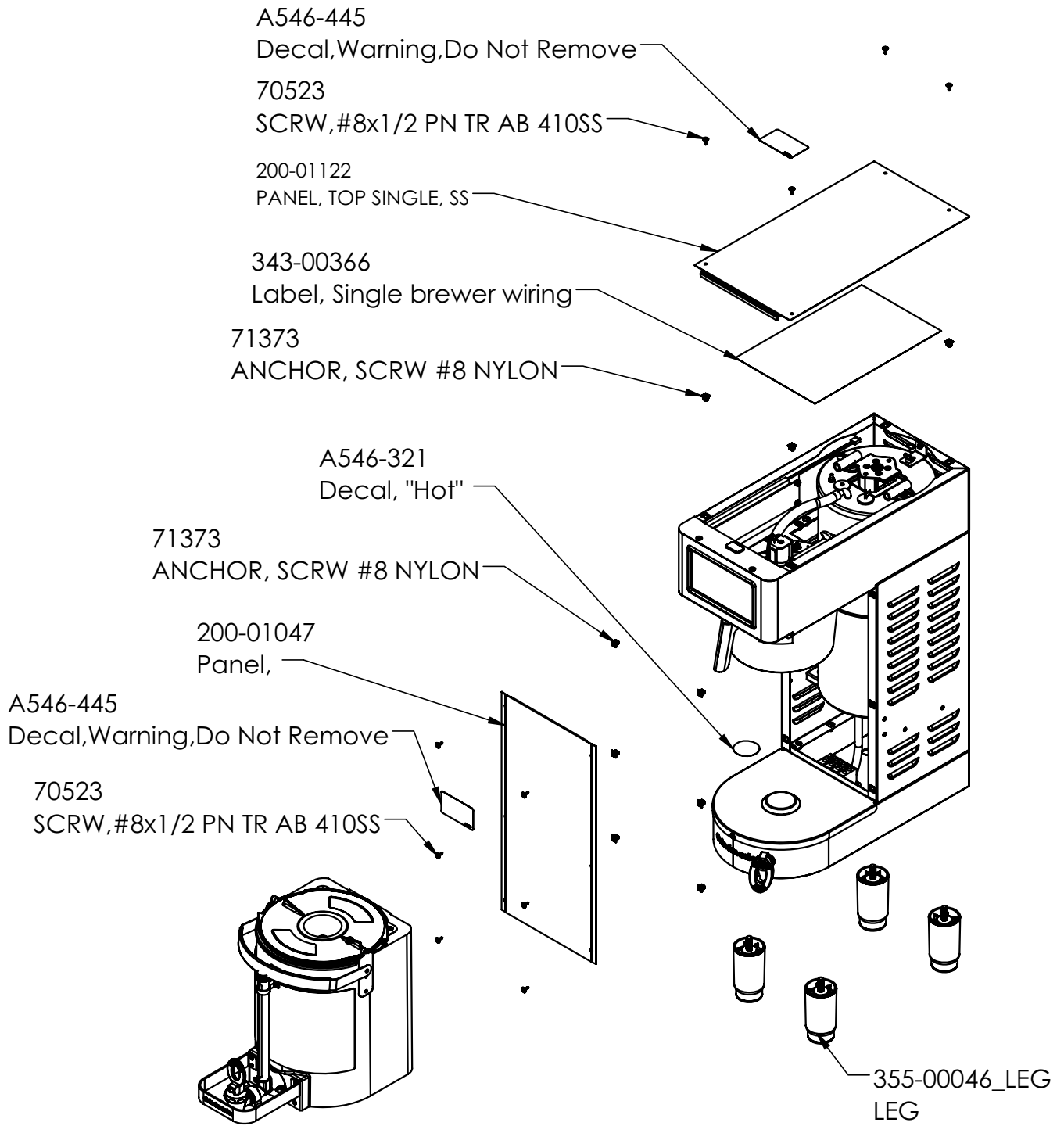

Parts Diagram and List (continued)

1004-003 Top level panels

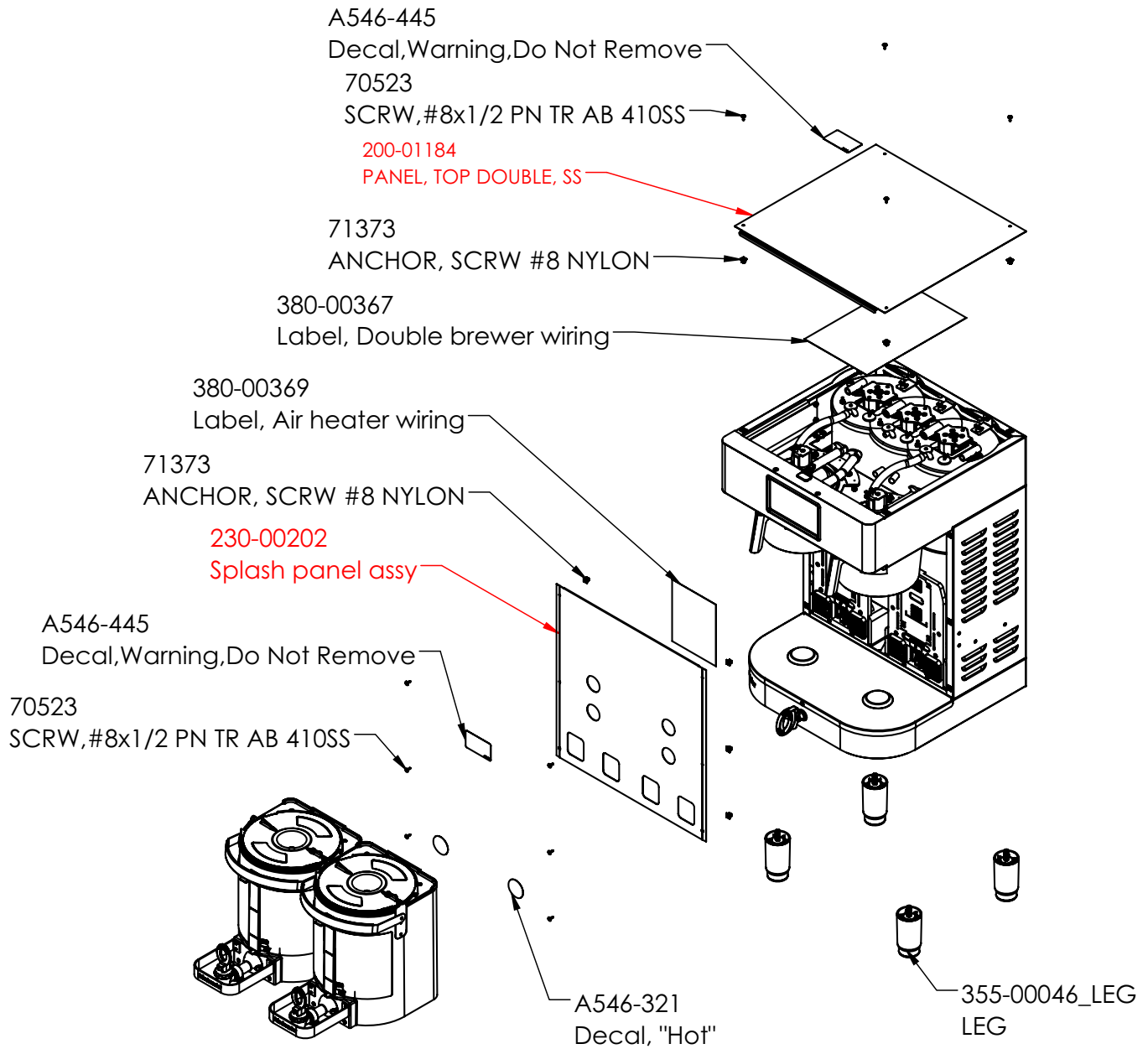

Parts Diagram and List (continued)

1004-004 Top level panels

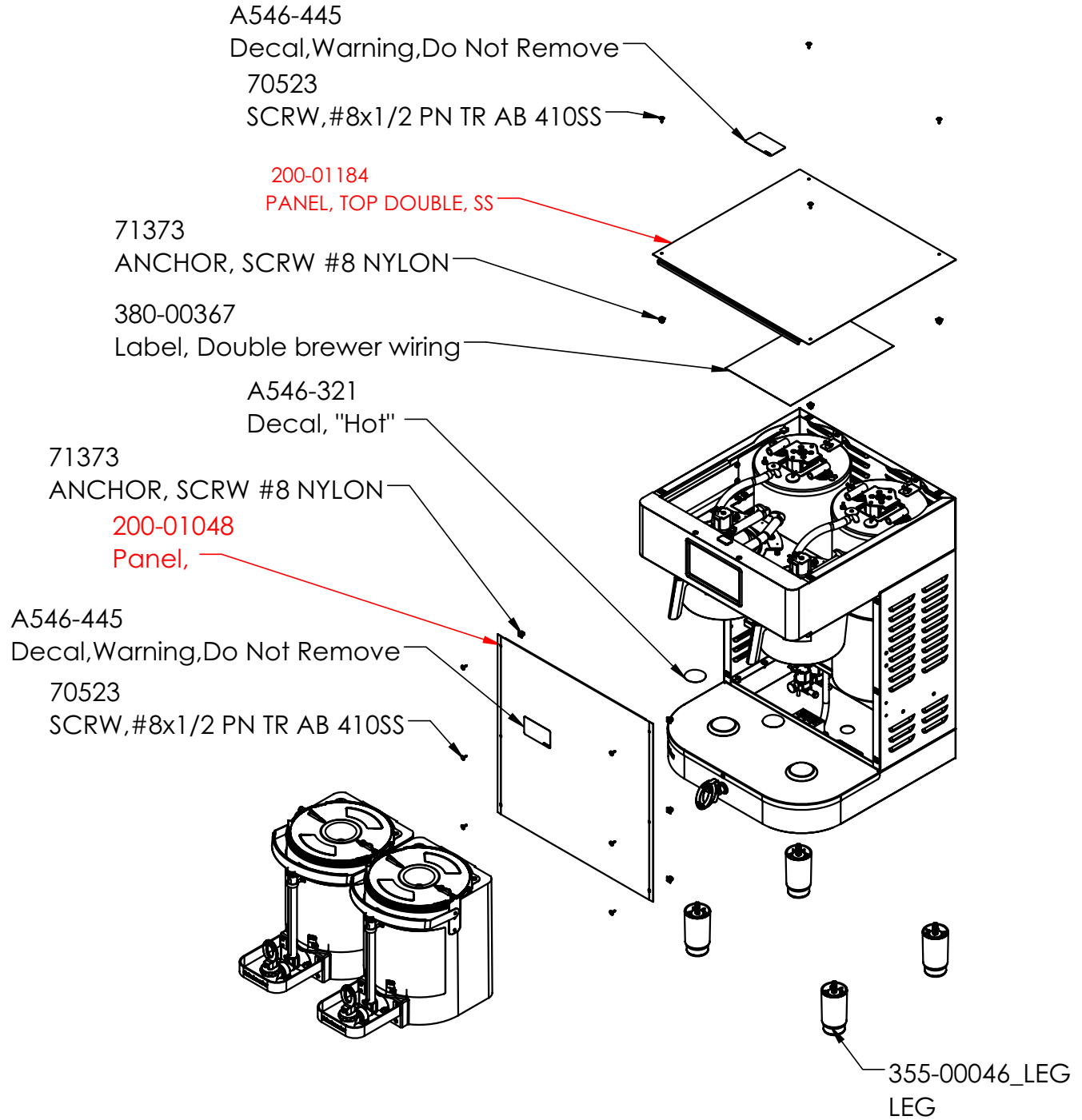

Parts Diagram and List (continued)

1004-005 Top level panels

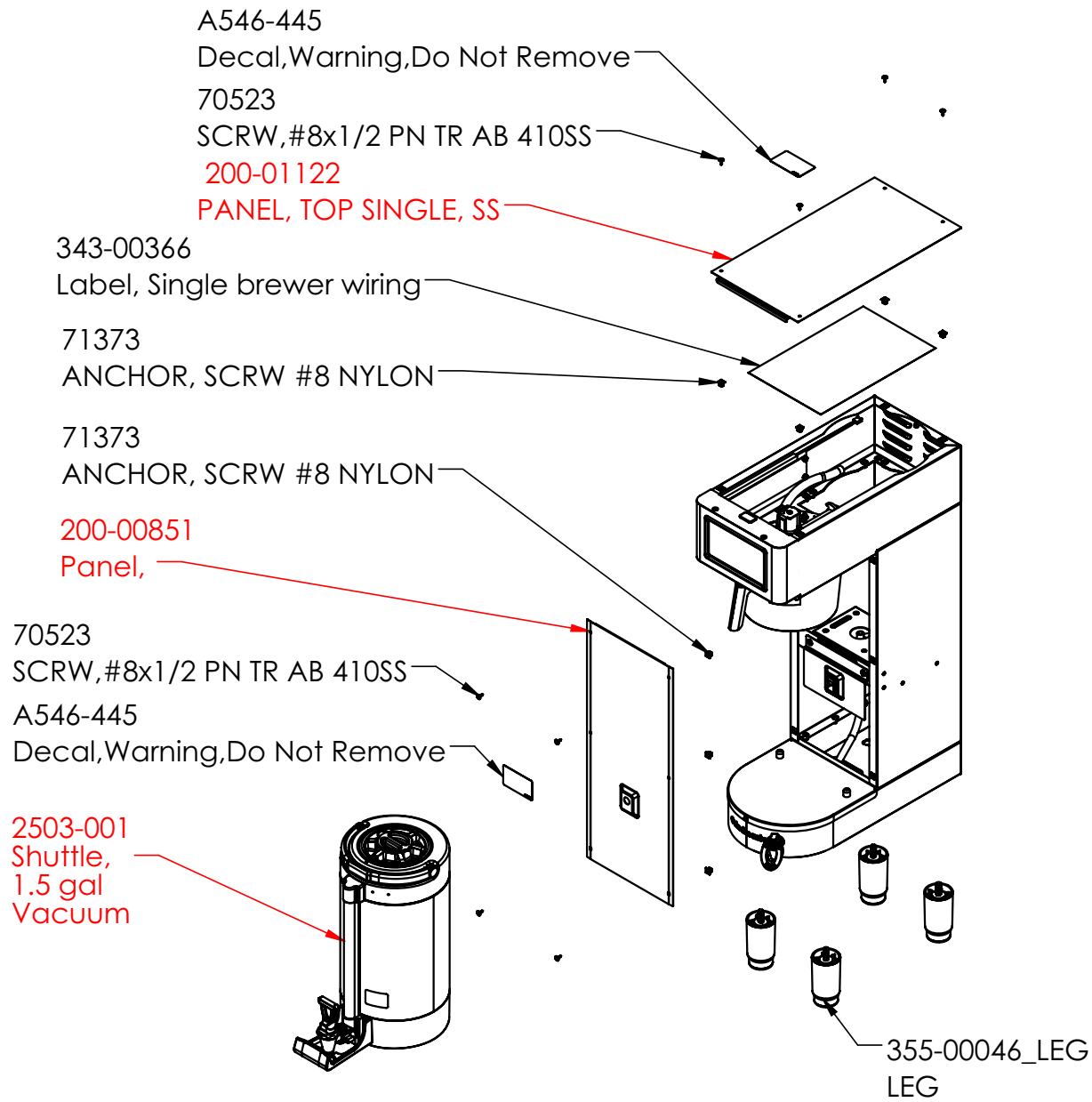

Parts Diagram and List (continued)

1004-006 Top level panels

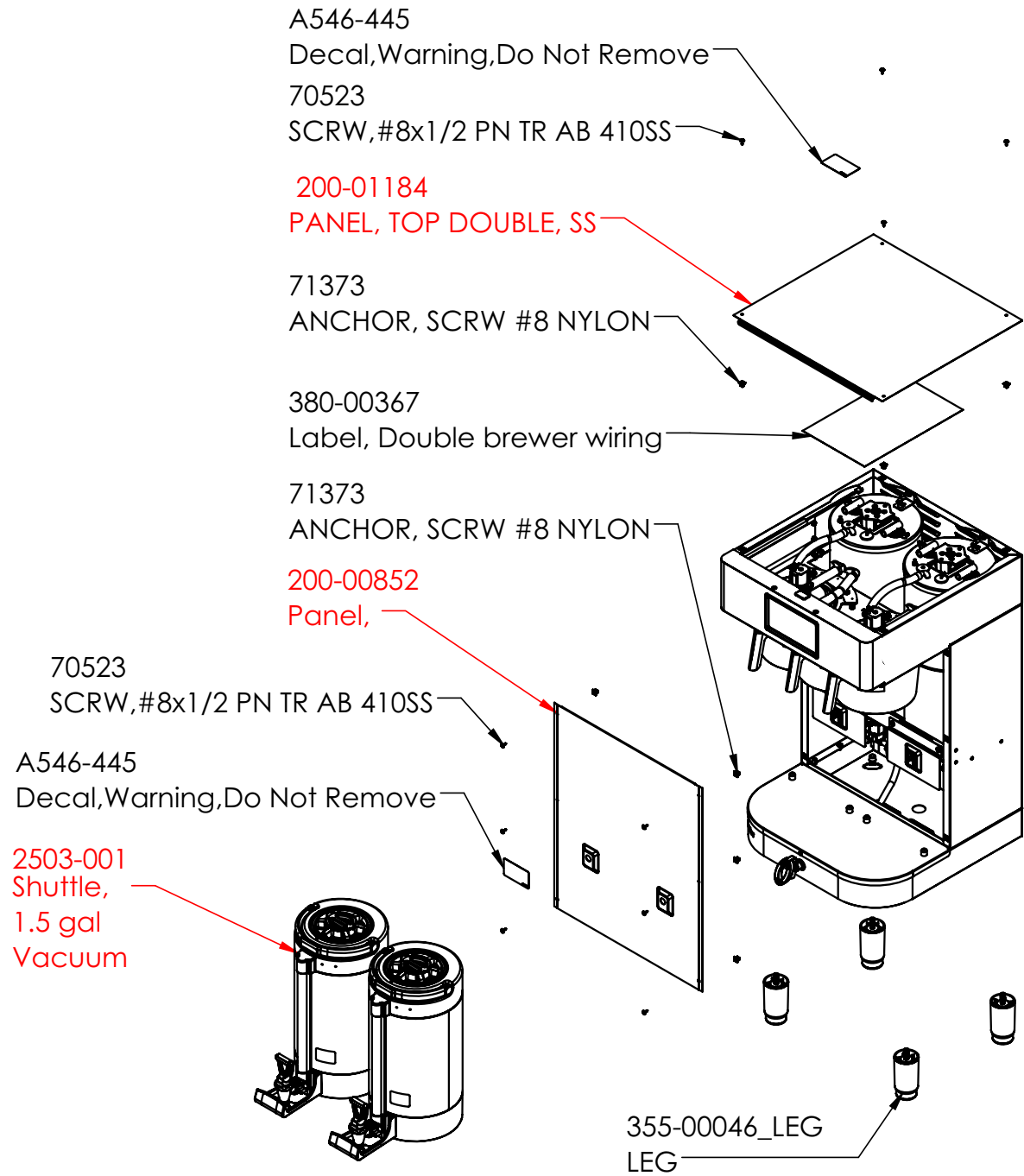

Parts Diagram and List (continued)

230-00143 Top chassis assy-Single

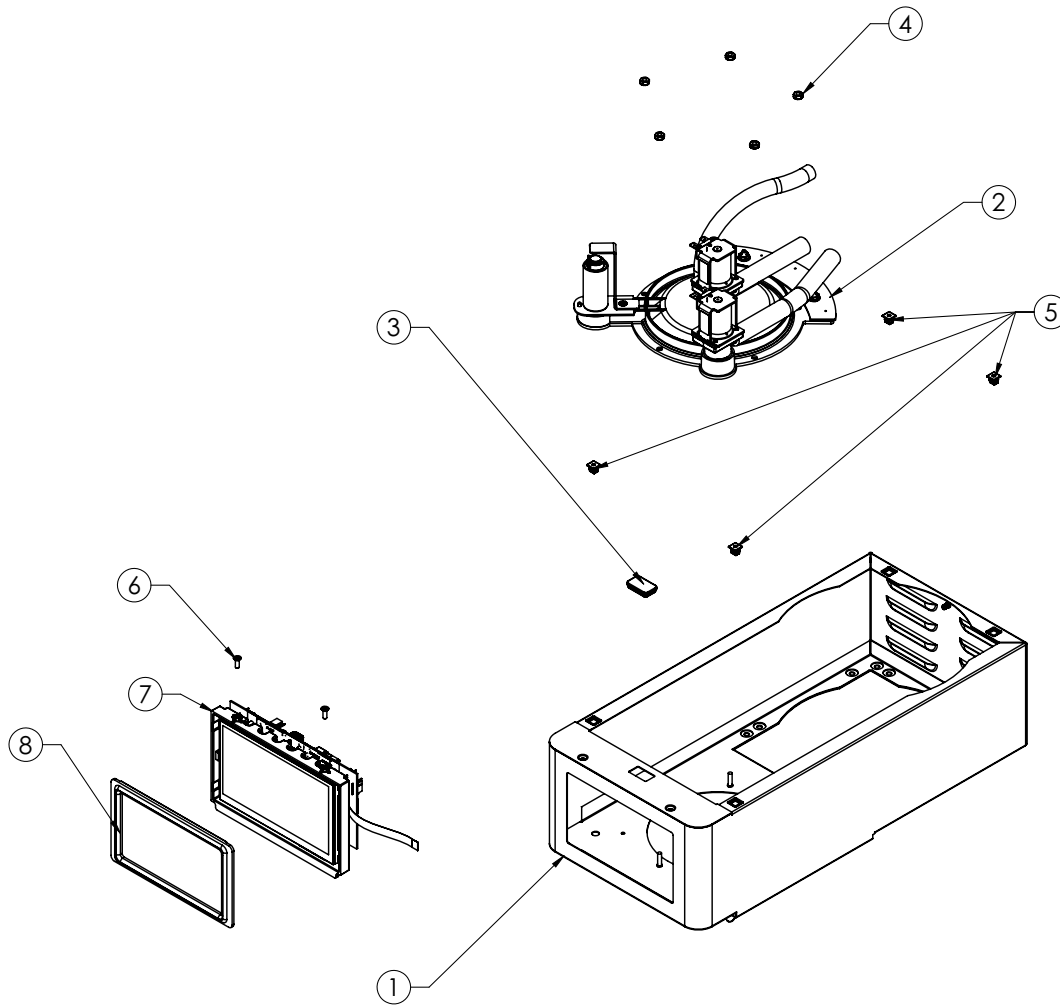

ITEM NO.	PART NUMBER	DESCRIPTION	230-00143 QTY.
1	200-01594	TOP WELDMENT, SS SINGLE W/O SIDELIGHT	1
2	230-00099	Assy, Single brewer dome	1
3	210-00475	Cover, Rubber USB	1
4	71129	NUT, 8-32 KEPS SS	5
5	71373	ANCHOR, SCRW #8 NYLON	4
6	72045	Scrw, #8 x 1/2" type B SS FHP	2
7	230-00166	Control assembly, Coffee & Tea	1
8	290-00116	GASKET, 7" TRIM	1

Parts Diagram and List (continued)

230-00166 Display assembly

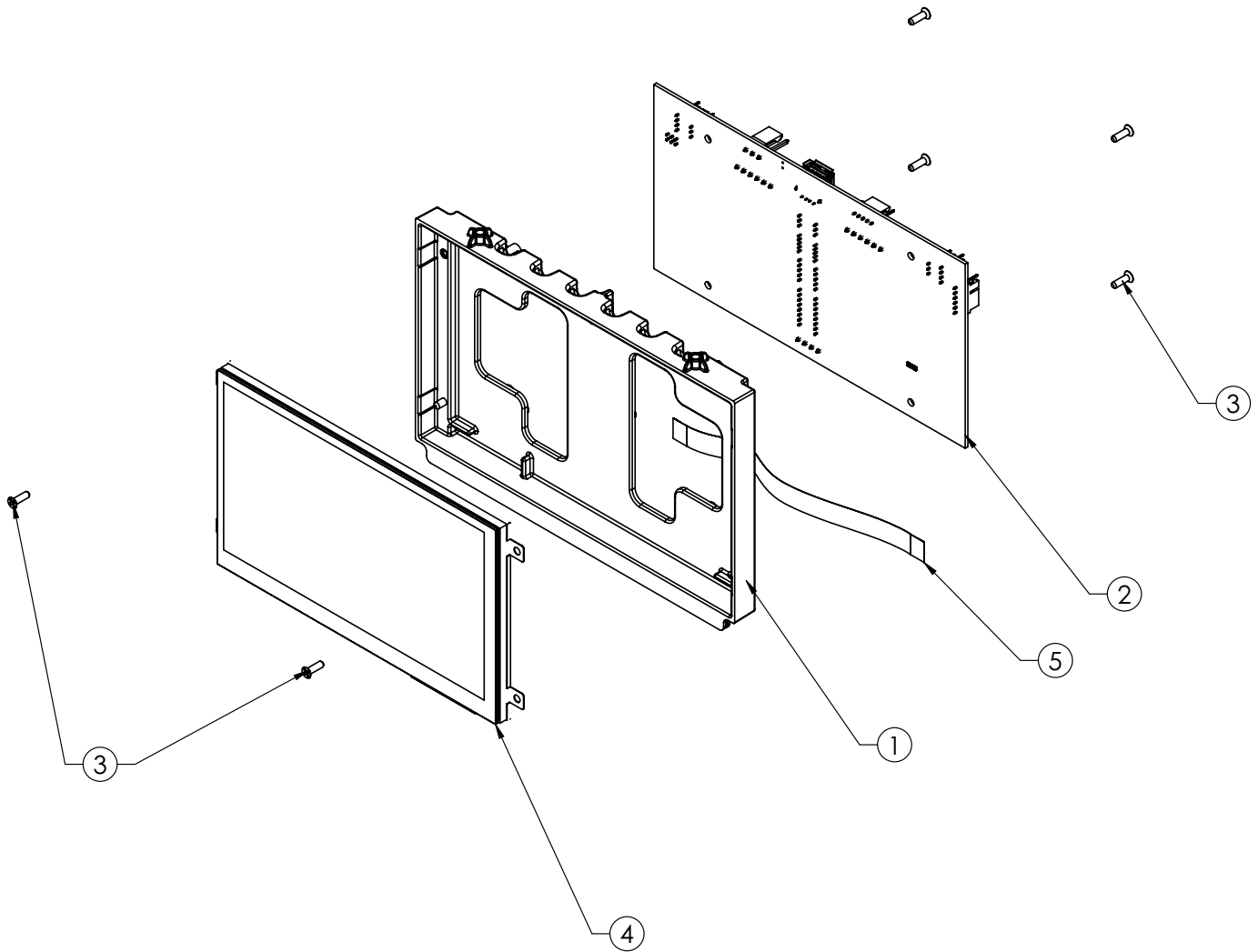

ITEM NO.	PART NUMBER	DESCRIPTION	QTY.
1	210-00588	BRACKET, 7" DISPLAY	1
2	349-00036	Control, Coffee brewer	1
3	72042	Screw, Type A #4x3/8" FH PH SS	6
4	345-00041	DISPLAY, 7" BACK MOUNT	1
5	343-00114	RIBBON CABLE, 3.5 INCH LCD	1

Parts Diagram and List (continued)

230-00099 Dome assembly

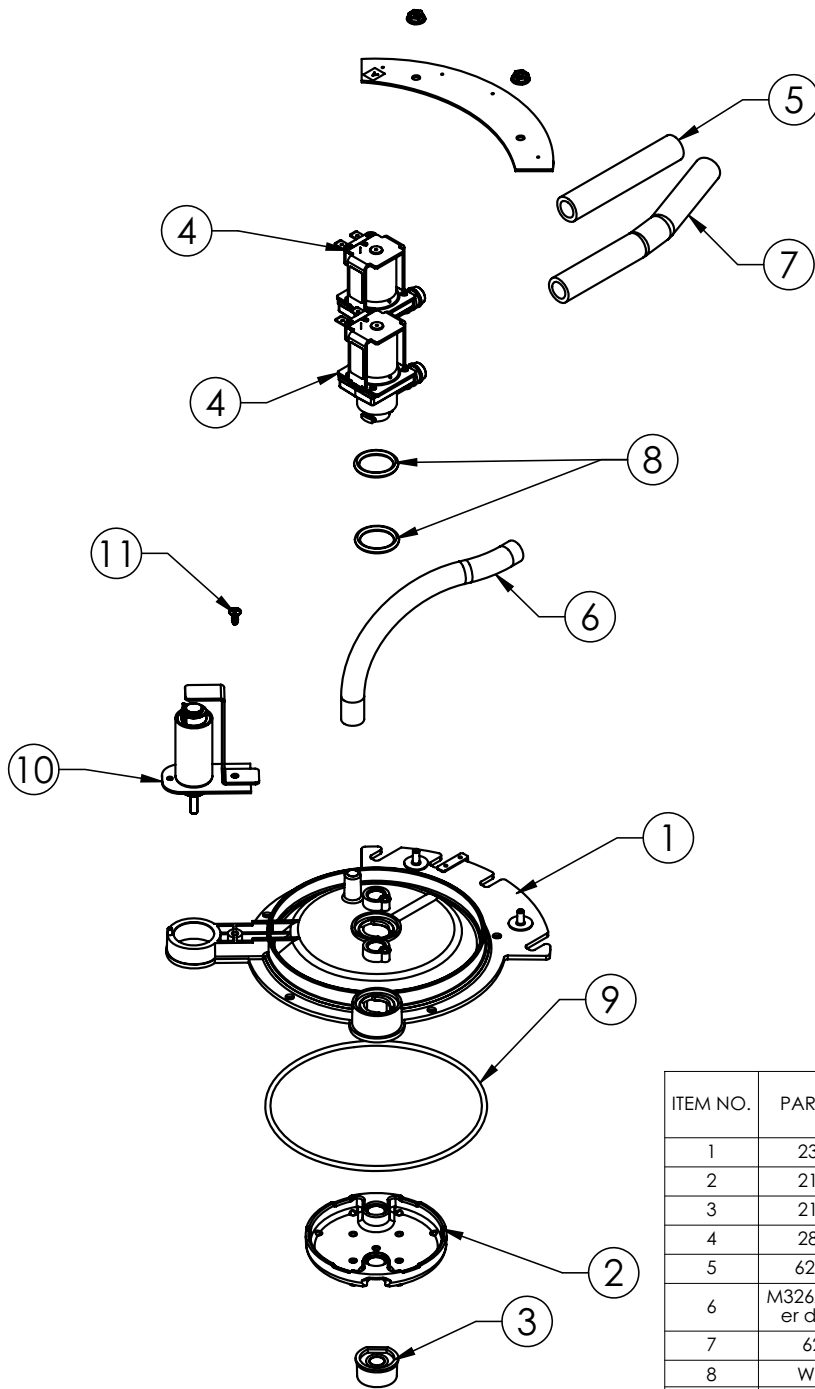

ITEM NO.	PART NUMBER	Dome assy/QT Y.	DESCRIPTION
1	230-00153	1	Dome assembly
2	210-00480	1	Sprayhead, Molded brewer
3	210-00479	1	Nozzle, Bypass
4	280-00089	2	Valve, 24vdc bayonet dump
5	62271_4.5L	1	Tubing, Tank to brew valve
6	M326AL_8L_Brew er dome vent	1	Tubing, Tank vent
7	62271_7L	1	Tubing, Tank to bypass
8	W0340022	2	O-RING, #213
9	290-00088	1	O-ring, 2-255 silicone rubber
10	230-00200	1	Assy,Lock solenoid with bracket
11	350-00131	1	SCREW, #8 X 3/8, HI-LO, PH TH SS
12	348-00043	1	Control-Brewer position sensor
13	350-00070	2	Nut, #10 stud speed
14	350-00084	2	SCREW, 4-24 X 3/8, HI-LO, PH PH SS

Parts Diagram and List (continued)

230-00102 Tank assembly

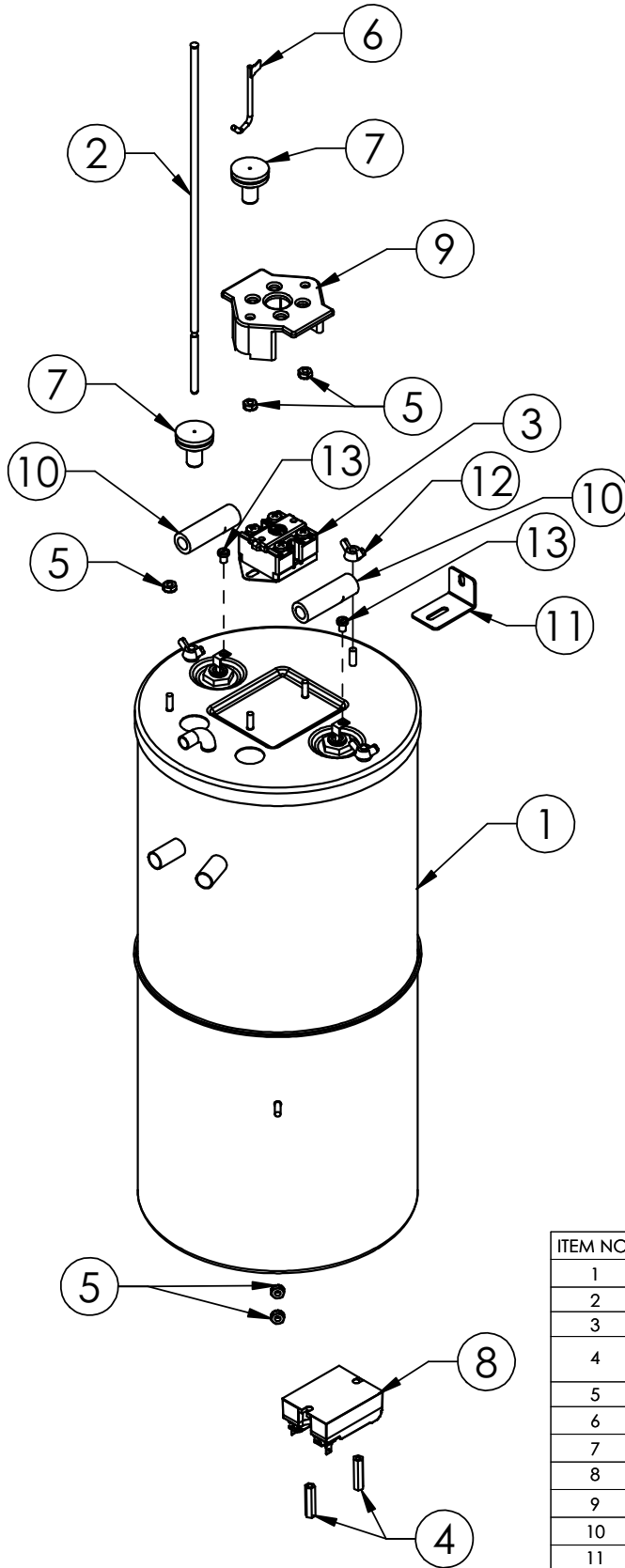

ITEM NO.	PART NUMBER	QTY.	DESCRIPTION
1	230-00118	1	TANK ASSY, HOT WATER
2	61128	1	PROBE, THERMISTOR 12"
3	321-00023	1	Thermostat, 66TM 40A manual reset
4	351-00024	2	Spacer, 8-32 x 1/4" hex x 1"L
5	71129	5	NUT, 8-32 KEPS SS
6	61108	1	PROBE, WATER LEVEL, SS
7	290-00105	2	GROMMET, PROBE, LEVEL SENSOR
8	346-00033	1	Relay, 50A solid state
9	210-00601	1	Insulator, Tank terminal
10	63665	2	Insulator, Heater terminal
11	200-01259	1	Bracket, Tank retaining
12	A540-203	1	# 10-24 WING NUT, SS
13	P079A	2	Screw, 10-32 x 1/4 SL HD Brass

Parts Diagram and List (continued)

230-00107 Single heated shuttle chassis assembly

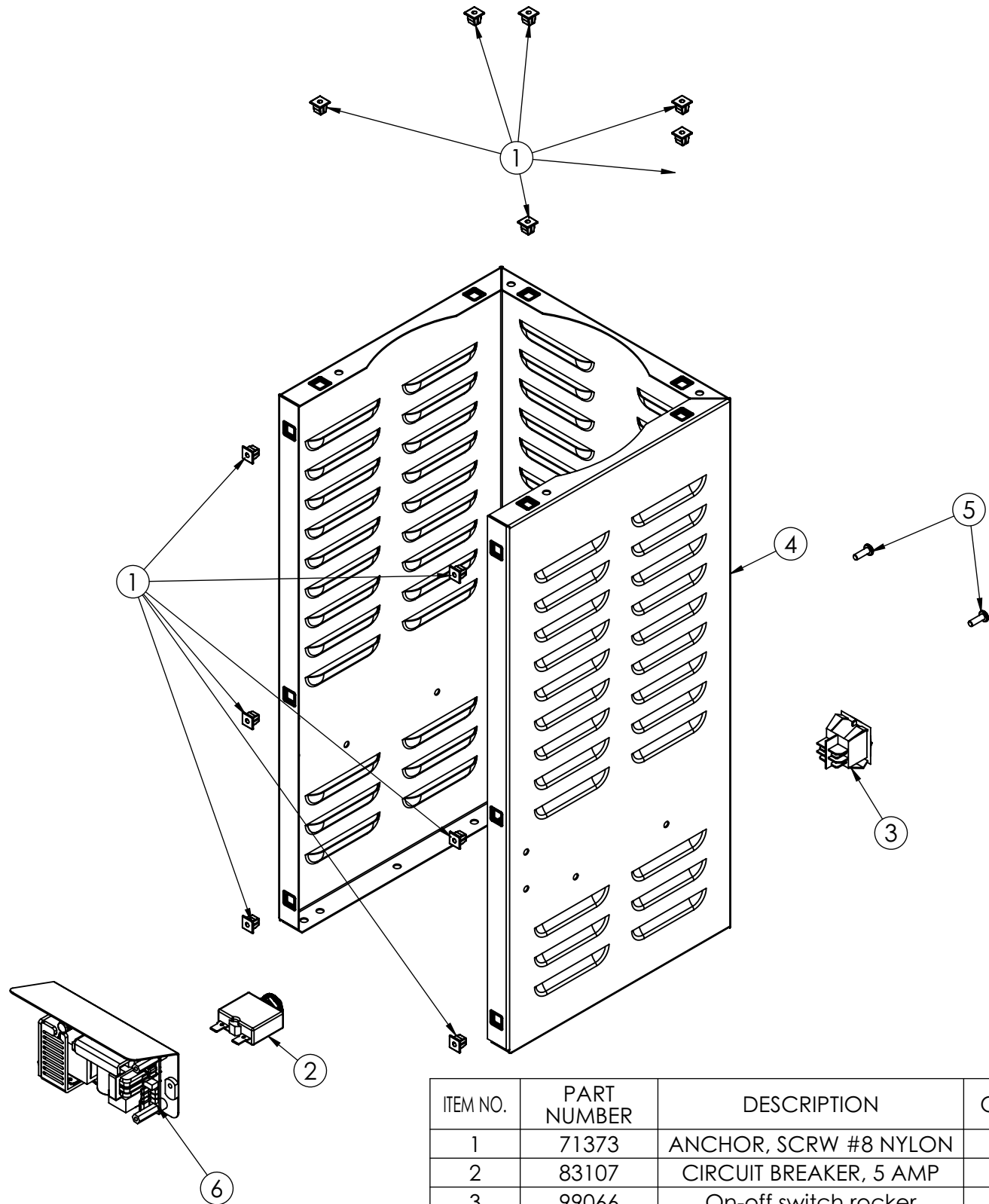

ITEM NO.	PART NUMBER	DESCRIPTION	QTY.
1	71373	ANCHOR, SCRW #8 NYLON	12
2	83107	CIRCUIT BREAKER, 5 AMP	1
3	99066	On-off switch rocker	1
4	200-00843	Tower, Single shuttle SS	1
5	07044-02	SCR #8-32X1/2" PH FIL ZNC	2
6	230-00196	Assy, Power supply	1

Parts Diagram and List (continued)

230-00108 Double heated shuttle chassis assembly

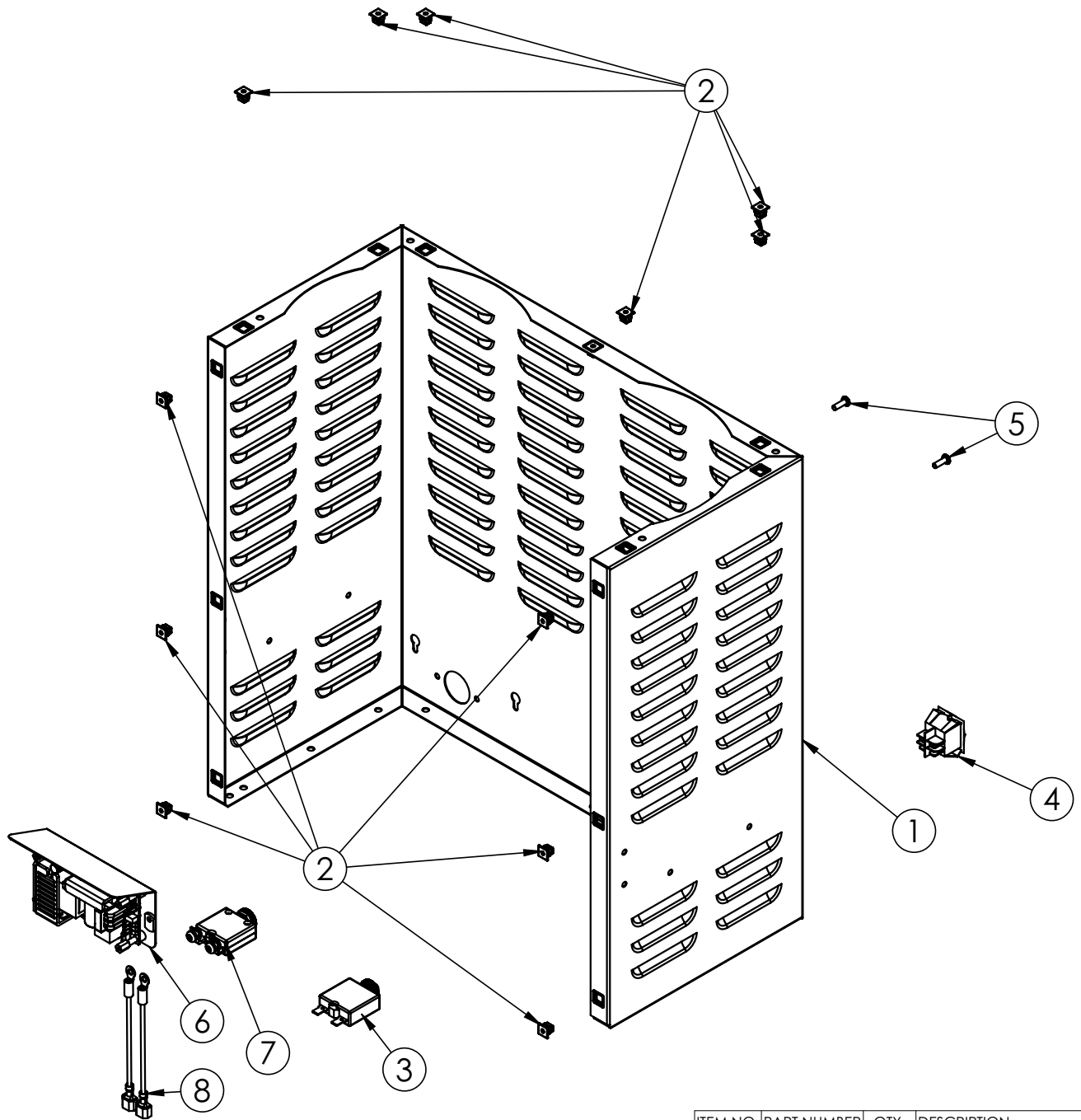

ITEM NO.	PART NUMBER	QTY.	DESCRIPTION
1	200-00844	1	Wrap, Double shuttle
2	71373	13	ANCHOR, SCRW #8 NYLON
3	346-00035	1	CIRCUIT BREAKER, 4 AMP
4	99066	1	On-off switch rocker
5	07044-02	2	SCR #8-32X1/2" PH FIL ZNC
6	230-00196	1	Assy, Power supply
7	346-00057	1	Circuit Breaker, 40A thermal
8	343-00352	1	Harness,Circuit breaker adapter

Parts Diagram and List (continued)

230-00109 Single vacuum shuttle chassis

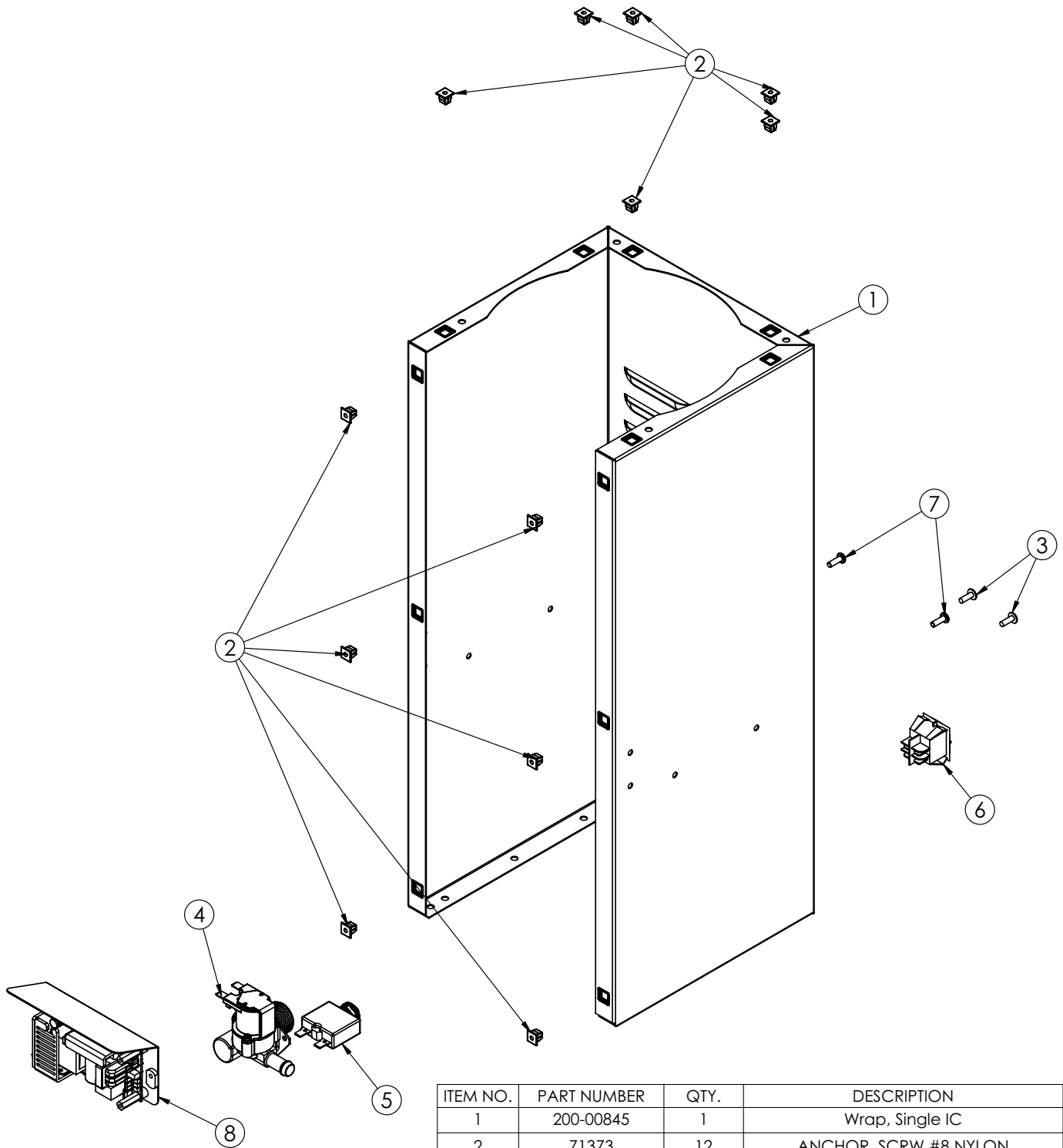

ITEM NO.	PART NUMBER	QTY.	DESCRIPTION
1	200-00845	1	Wrap, Single IC
2	71373	12	ANCHOR, SCRW #8 NYLON
3	99309	2	Screw M4-0.7 x 12 PH PN MS SS 304
4	280-00066	1	Valve, RPE 24VDC Single 6L/min
5	83107	1	CIRCUIT BREAKER, 5 AMP
6	99066	1	On-off switch rocker
7	07044-02	2	SCR #8-32X1/2" PH FIL ZNC
8	230-00196	1	Assy, Power supply

Parts Diagram and List (continued)

230-00110 Double vacuum shuttle chassis

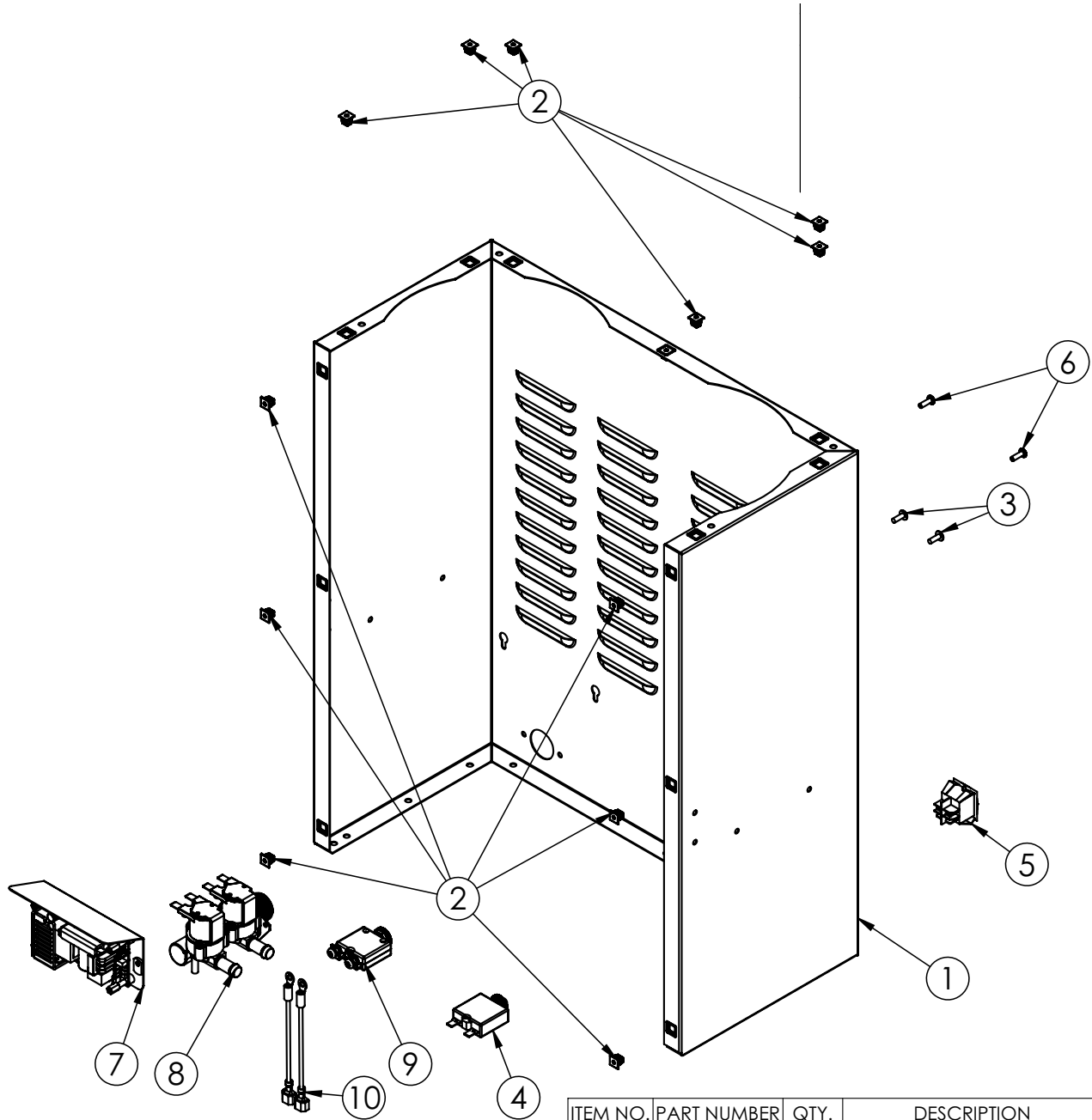

ITEM NO.	PART NUMBER	QTY.	DESCRIPTION
1	200-00846	1	Wrap, Double IC
2	71373	13	ANCHOR, SCRW #8 NYLON
3	99309	2	Screw M4-0.7 x 12 PH PN MS SS 304
4	346-00035	1	CIRCUIT BREAKER, 4 AMP
5	99066	1	On-off switch rocker
6	07044-02	2	SCR #8-32X1/2" PH FIL ZNC
7	230-00196	1	Assy, Power supply
8	280-00065	1	Valve, 24VDC dual 6 l/min inlet
9	346-00057	1	Circuit Breaker, 40A thermal
10	343-00352	1	Harness, Circuit breaker adapter

Parts Diagram and List (continued)

230-00196 Power supply assembly

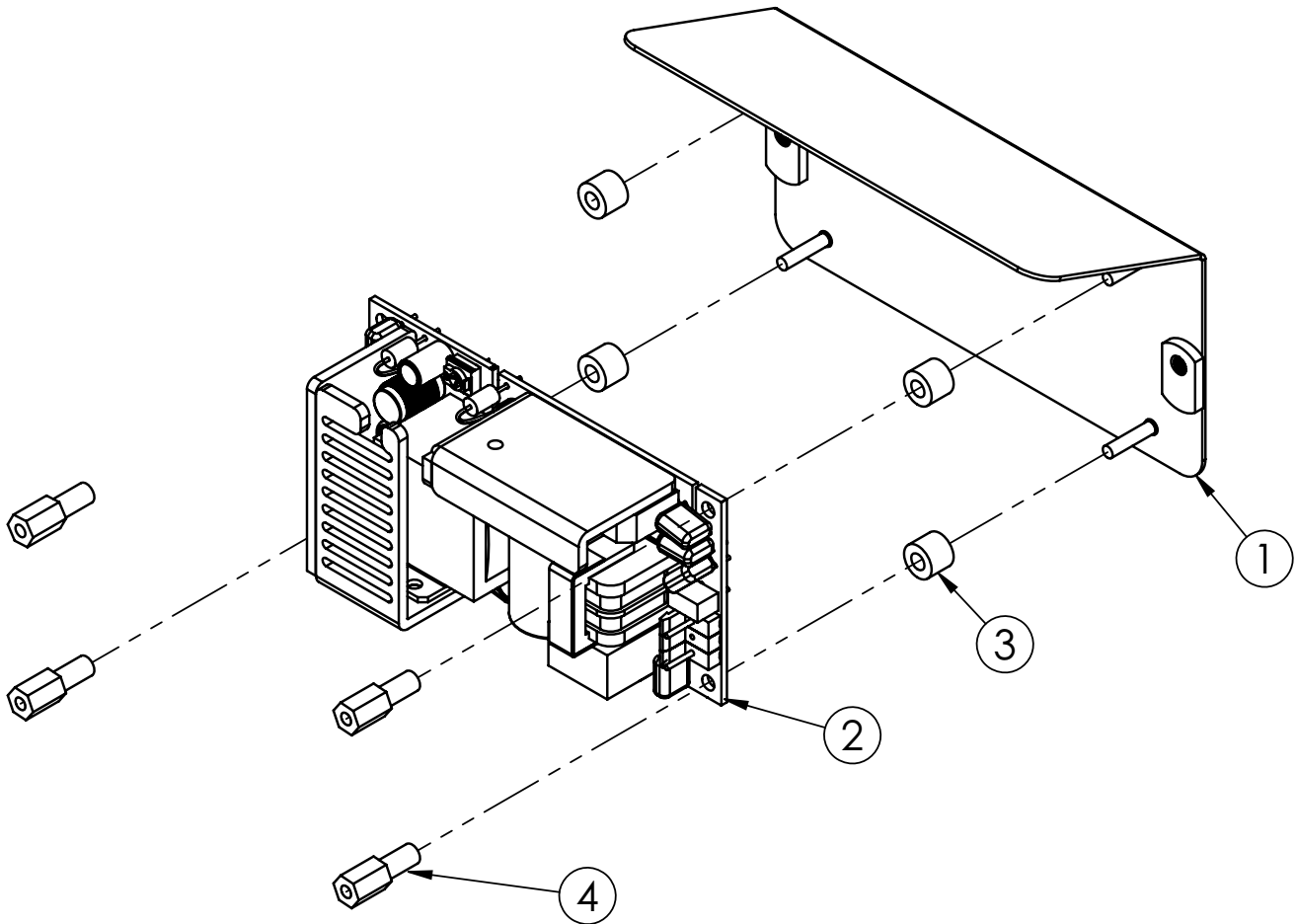

ITEM NO.	PART NUMBER	QTY.	DESCRIPTION
1	200-01332	1	Bracket, Power supply drip weldment
2	346-00036	1	Power supply, CUI 24vdc
3	356-00052	4	Spacer, #6ID x 5/16OD x 1/4L n
4	356-00062	4	Standoff,4-40x0.75 Aluminum

Parts Diagram and List (continued)

230-00105 Single base assembly

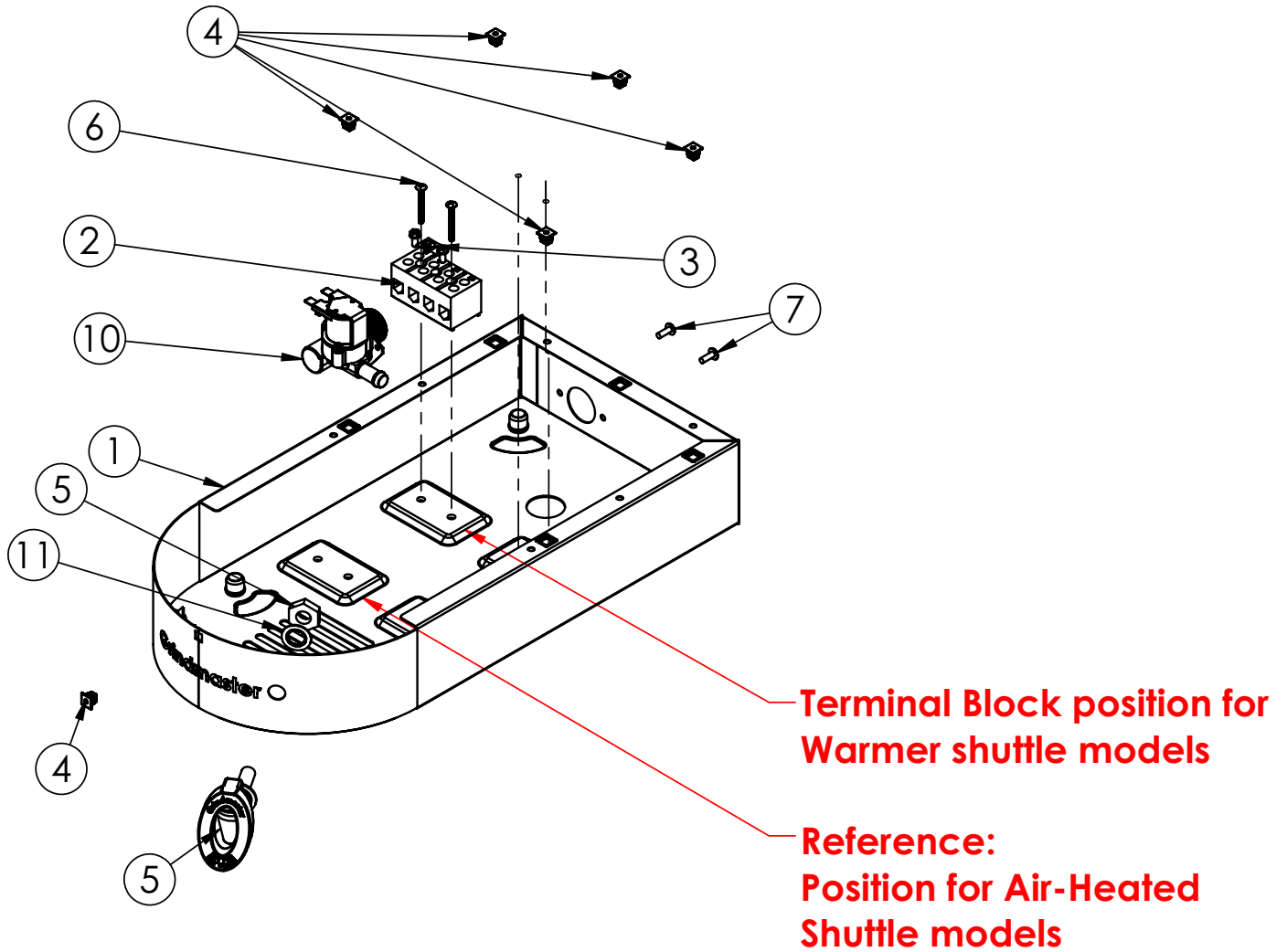

ITEM NO.	PART NUMBER	DESCRIPTION	QTY.
1	230-00137	WRAP ASSY, BASE, SINGLE, STAINLESS	1
2	A531-035	TERM BLOCK, 4 POS., 85 AMPS 6	1
3	10073	Label, Ground Symbol	1
4	71373	ANCHOR, SCRW #8 NYLON	6
5	280-00072	Faucet, Hot water valve	1
6	A601018	SCREW, #6-32X1-1/4 PH HEAD	2
7	99309	Screw M4-0.7 x 12 PH PN MS SS 304	2
8	71160	CLIP, SIPHON HOSE-BLK W/ ADHSV	2
9	0076	SCR, 8-32 X 3/8 HEX HD, GRN	2
10	280-00066	Valve, RPE 24VDC Single 6L/min	1
11	A541-020	Washer, 1/2 Int tooth L/W,410 S/S	2

Parts Diagram and List (continued)

230-00106 Double base assembly

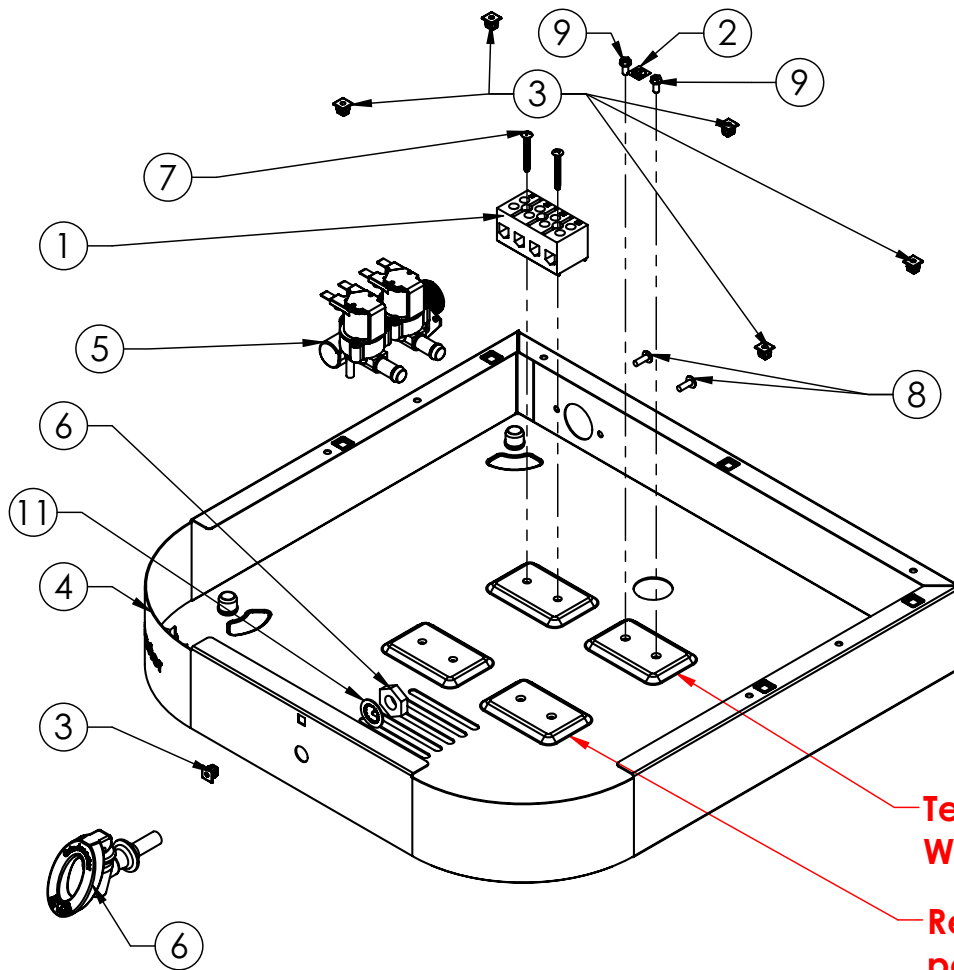

Terminal Block position for Warmer shuttle models

Reference: Terminal Block position for Air-Heated Shuttle models

ITEM NO.	PART NUMBER	DESCRIPTION	QTY.
1	A531-035	TERM BLOCK, 4 POS., 85 AMPS 6	1
2	10073	Label, Ground Symbol	1
3	71373	ANCHOR, SCRW #8 NYLON	7
4	230-00139	WRAP ASSY, BASE, DOUBLE, STAINLESS	1
5	280-00065	Valve, 24VDC dual 6 l/min inlet	1
6	280-00072	Faucet, Hot water valve	1
7	A601018	SCREW, #6-32X1-1/4 PH HEAD	2
8	99309	Screw M4-0.7 x 12 PH PN MS SS 304	2
9	0076	SCR, 8-32 X 3/8 HEX HD, GRN	2
10	71160	CLIP, SIPHON HOSE-BLK W/ ADHSV	2
11	A541-020	Washer, 1/2 Int tooth L/W,410 S/S	1

Parts Diagram and List (continued)

230-00113 Single IC base assembly

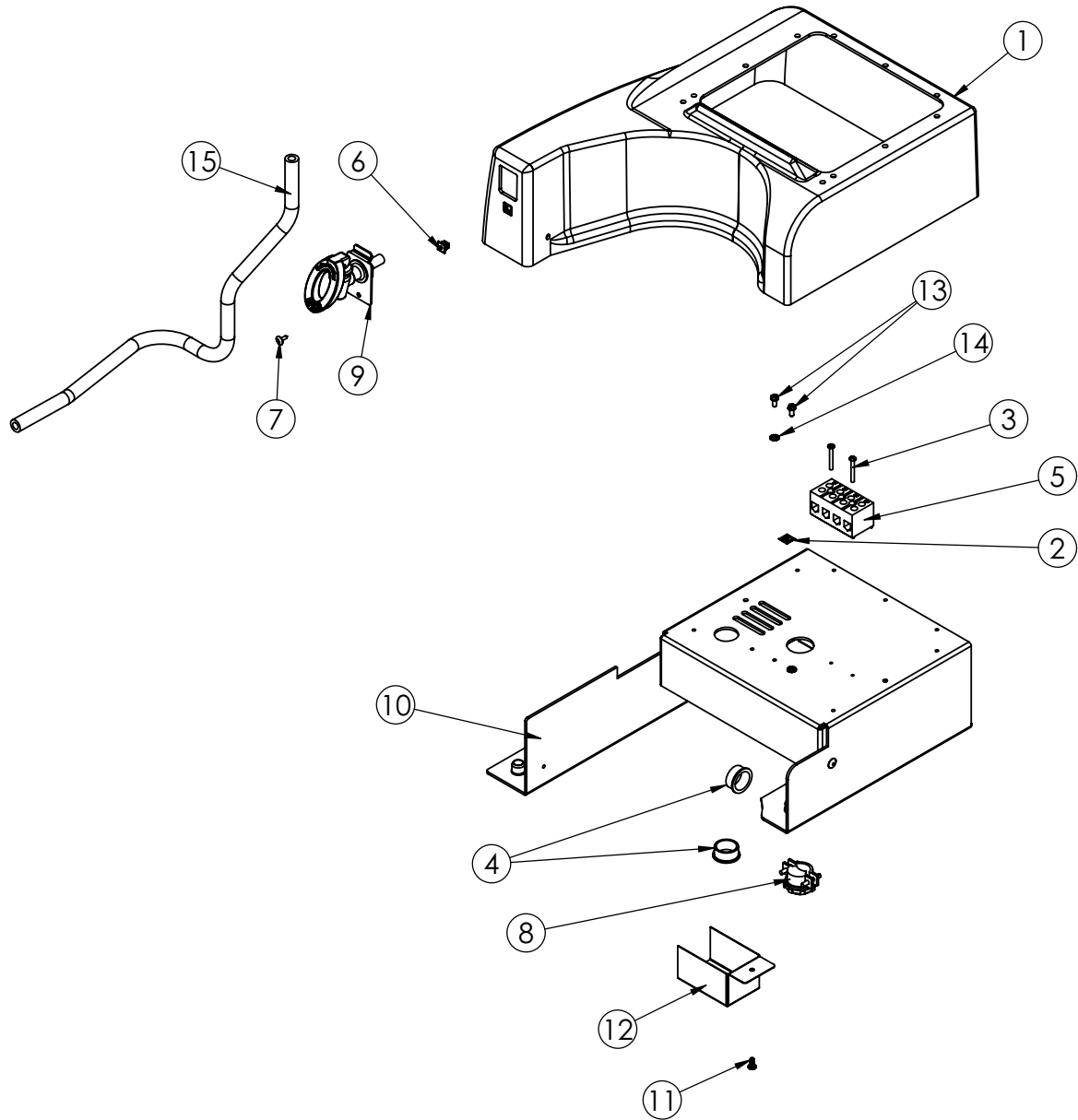

ITEM NO.	PART NUMBER	DESCRIPTION	QTY.
1	210-00500	Cover, Single IC base	1
2	10073	Label, Ground Symbol	1
3	A539-110	Screw, 6-32 x 1-1/8 PH PN HD MS 18-8 SS	2
4	60382	Bushing, Snap 1" Heyco	2
5	A531-035	TERM BLOCK, 4 POS., 85 AMPS 6	1
6	71373	ANCHOR, SCRW #8 NYLON	1
7	70523	SCRW, #8x1/2 PN TR AB 410SS	1
8	07920	Connector, 3/4 conduit	1
9	230-00132	Assy, Faucet with mounting bracket	1
10	230-00145	BRACKET ASSY, BASE, SINGLE	1
11	61303	Screw, #8 x 3/8 black trilobe	1
12	200-01112	SHROUD, TUBE	1
13	0076	SCR, 8-32 X 3/8 HEX HD, GRN	2
14	61187	WSH #8 EXT STR LCK	2
15	71155_IC faucet tube	24" 71155 tubing	1

Parts Diagram and List (continued)

230-00114 Double IC assembly

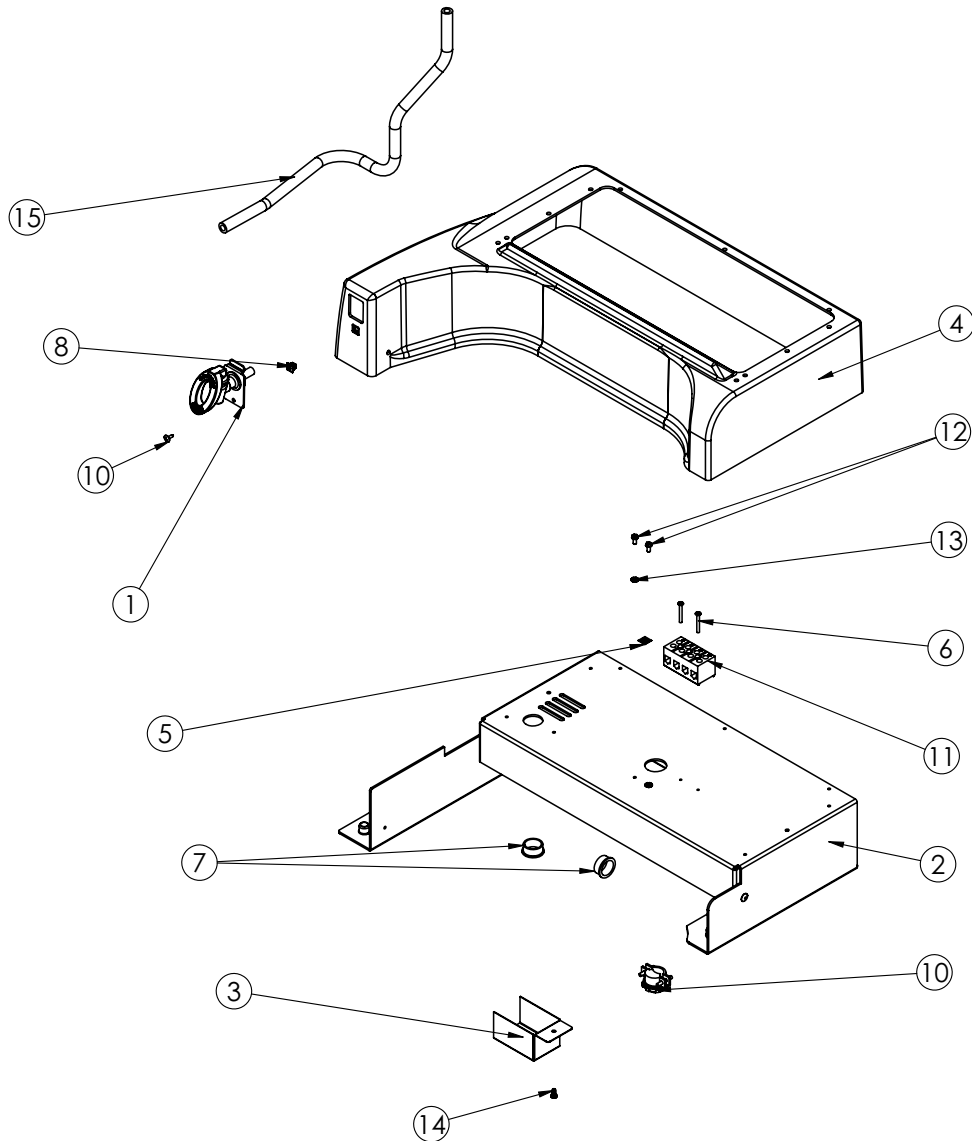

ITEM NO.	PART NUMBER	DESCRIPTION	230-00114/QTY.
1	230-00132	Assy, Faucet with mounting bracket	1
2	230-00146	BASE ASSY, DOUBLE	1
3	200-01112	SHROUD, TUBE	1
4	210-00501	Cover, Double IC base	1
5	10073	Label, Ground Symbol	1
6	A539-110	Screw, 6-32 x 1-1/8 PH PN HD MS 18-8 SS	2
7	60382	Bushing, Snap 1" Heyco	2
8	71373	ANCHOR, SCRW #8 NYLON	1
10	70523	SCRW, #8x1/2 PN TR AB 410SS	1
10	07920	Connector, 3/4 conduit	1
11	A531-035	TERM BLOCK, 4 POS., 85 AMPS 6	1
12	0076	SCR, 8-32 X 3/8 HEX HD, GRN	2
13	61187	WSH #8 EXT STR LCK	2
14	61303	Screw, #8 x 3/8 black trilobe	1
15	71155_IC faucet tube	24" 71155 tubing	1

Parts Diagram and List (continued)

230-00148 Presence switch bracket

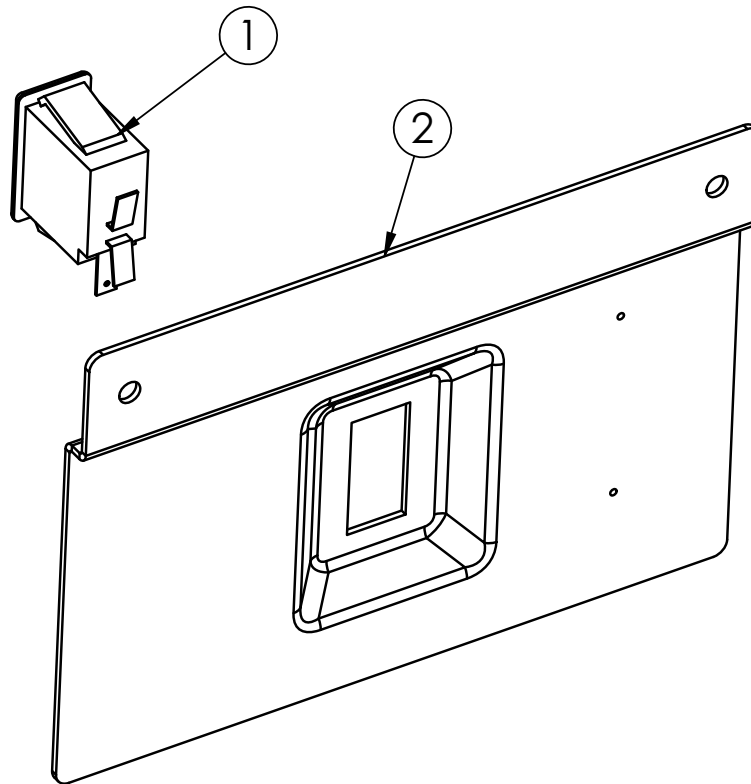

ITEM NO.	PART NUMBER	QTY.	DESCRIPTION
1	a531-025	1	SWITCH, PNL MNT INTERLOCK
2	200-01128	1	Bracket, Vacuum shuttle presence switch

Parts Diagram and List (continued)

230-00121 Single shuttle shelf with mixer

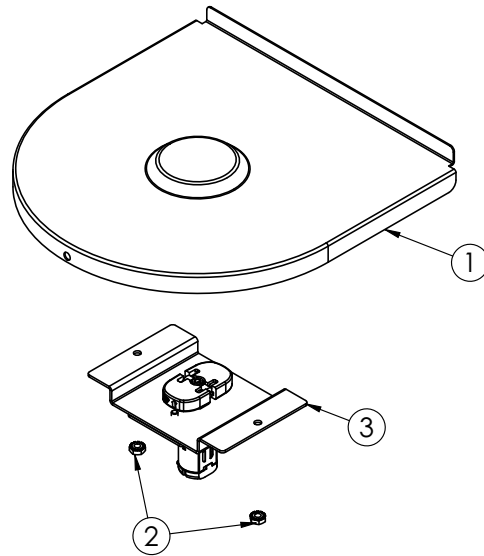

ITEM NO.	PART NUMBER	QTY.	DESCRIPTION
1	200-00894	1	Weldment, Single shuttle shelf
2	71129	3	NUT, 8-32 KEPS SS
3	230-00128	1	Assy, Stirrer motor

230-00122 Double shuttle shelf with mixers

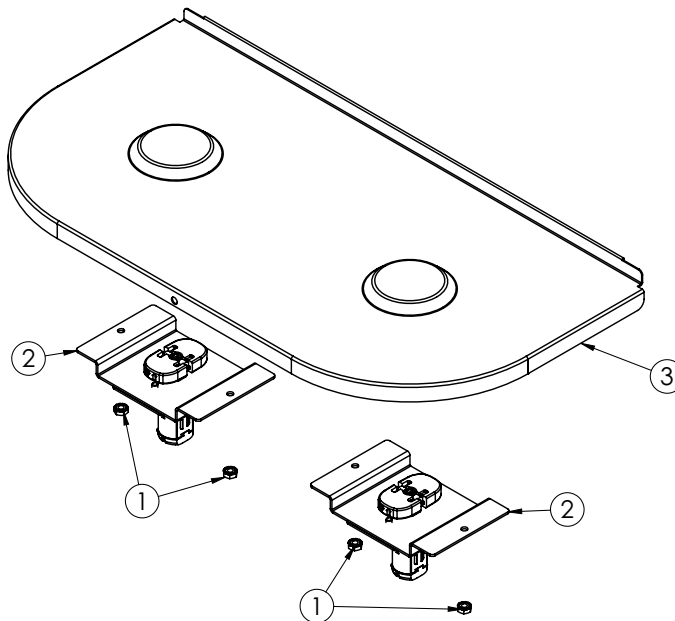

ITEM NO.	PART NUMBER	QTY.	DESCRIPTION
1	71129	5	NUT, 8-32 KEPS SS
2	230-00128	2	Assy, Stirrer motor
3	200-00895	1	Weldment, Double shuttle shelf

Parts Diagram and List (continued)

230-00149 Shuttle shelf with warmer

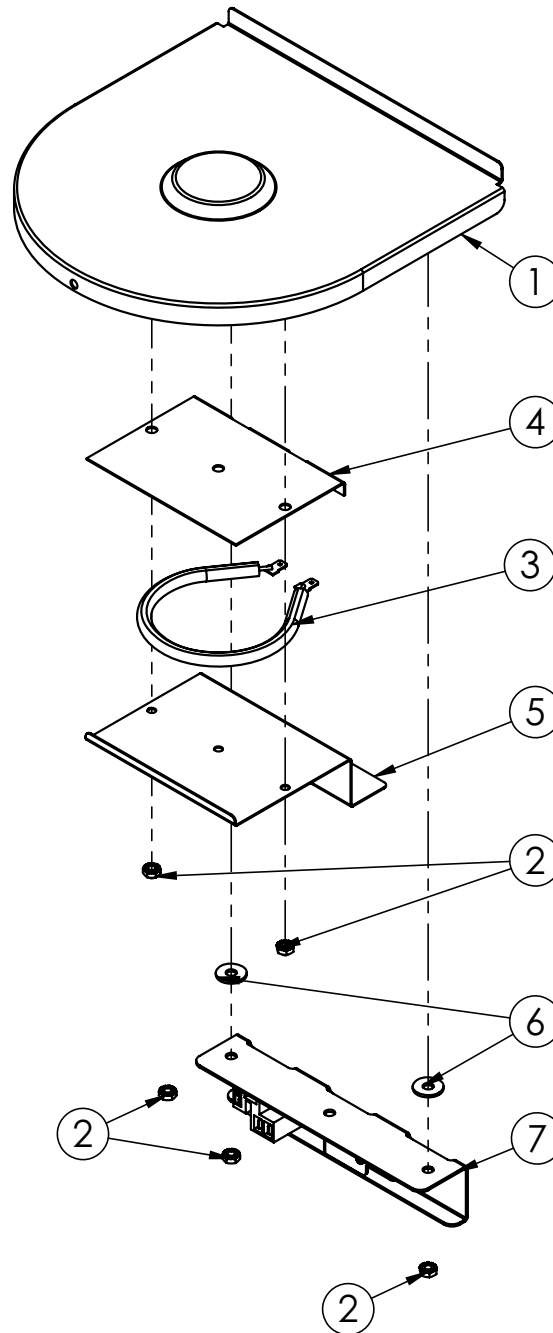

ITEM NO.	PART NUMBER	QTY.	DESCRIPTION
1	200-00894	1	Weldment, Single shuttle shelf
2	71129	5	NUT, 8-32 KEPS SS
3	72029	1	HEATER, WARM 100W 240V
4	200-01118	1	Warmer heat sink
5	200-01117	1	Warmer keeper
6	61334	2	WASHER, SLINGER
7	230-00192	1	Assy, Warmer interlock switch

Parts Diagram and List (continued)

230-00192 Warmer interlock switch assembly

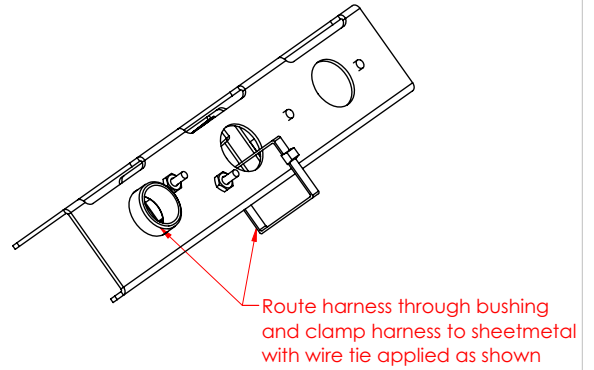
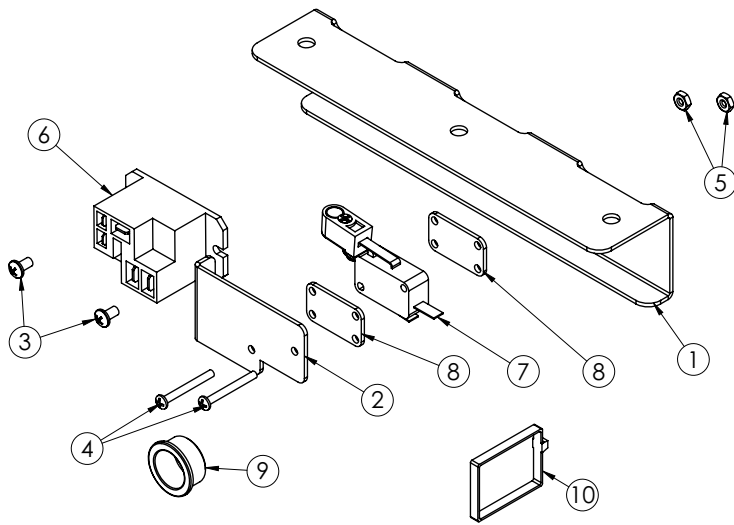

ITEM NO.	PART NUMBER	QTY.	DESCRIPTION
1	200-01304	1	Bracket, Warmer interlock switch
2	200-01311	1	Bracket, Interlock switch protector
3	P182A	2	SCR #6-32 X 1/4 PH PN SS
4	350-00134	2	SCREW, #4-40 X 1 PH PN MS SS, 18-8 SS
5	71128	2	Nut, 4-40 SS
6	71450	1	Relay,
7	72043	1	Assy, GNB basket out switch
8	200-01428	2	Spacer, microswitch
9	88031	1	SNAP BUSHING, HEYCO #2096
10	W0630802	1	Wire tie, 5" Nylon

Parts Diagram and List (continued)

230-00130 Shuttle shelf - vacuum shuttle

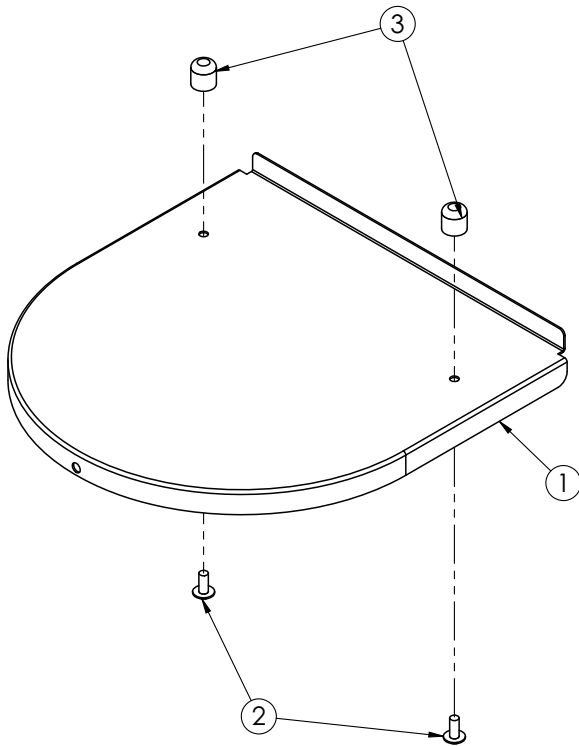

ITEM NO.	PART NUMBER	QTY.	DESCRIPTION
1	200-00896	1	Panel, Single IC shelf
2	A539-413	2	SCREW, 10-24 x 3/8" PHILIPS
3	A320-143	2	Air Pot Stopper

230-00121 Double shelf - vacuum shuttle

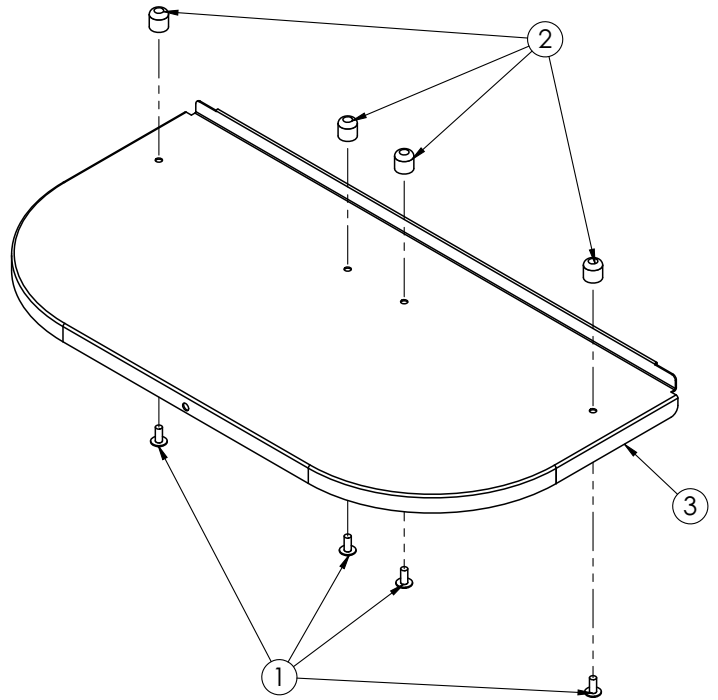

ITEM NO.	PART NUMBER	QTY.	DESCRIPTION
1	A539-413	4	SCREW, 10-24 x 3/8" PHILIPS
2	A320-143	4	Air Pot Stopper
3	200-00897	1	Panel, Double IC shelf

Parts Diagram and List (continued)

230-00126 Air heater assembly

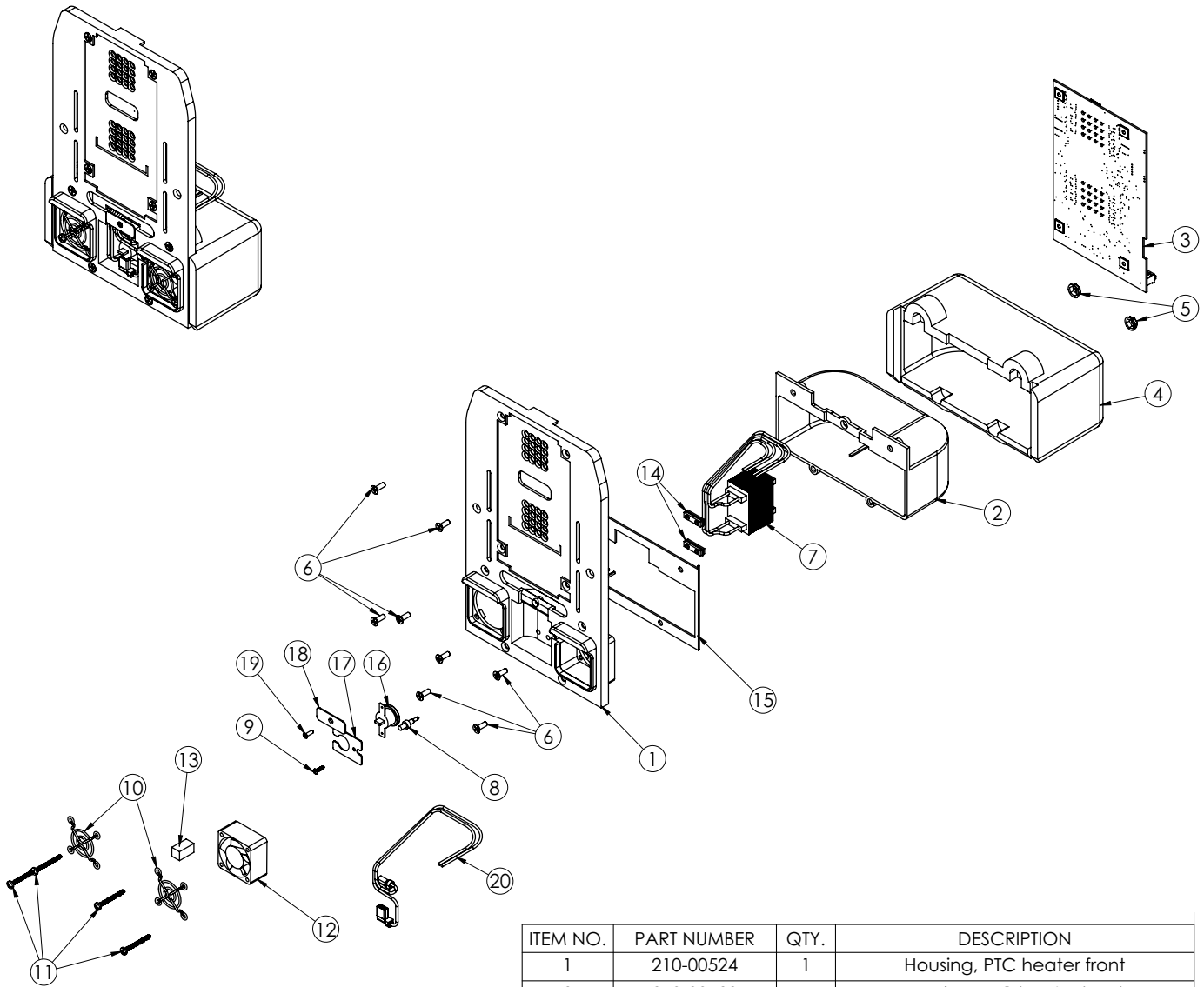

ITEM NO.	PART NUMBER	QTY.	DESCRIPTION
1	210-00524	1	Housing, PTC heater front
2	210-00523	1	Housing, PTC heater back
3	349-00048	1	Control, Shuttle heater
4	322-00019	1	Insulation, Air heater
5	350-00070	2	Nut, #10 stud speed
6	72045	8	Scrw, #8 x 1/2" type B SS FHP
7	320-00070	1	HEATER, 150W 120-240V PTC AIR
8	321-00026	1	Thermistor- 30Kohm minature
9	350-00072	1	SCREW, 4-24 X 3/8, HI-LO, PH PN SS
10	356-00050	2	Fan guard, 40mm SS wire
11	350-00044	4	SCREW, #6 X 1.25"L, HI-LO, PH PN HD
12	260-00032	1	Fan assy, 40mm x 20mm 24vdc hi-temp
13	W0670008	1	Strip, Rubber, Trim-Lok, 0.7" lg
14	210-00672	2	Gasket, PTC heater lead
15	290-00132	1	Gasket, Air heater shells
16	A536-023	1	Thermostat, Manual reset 105C cutout
17	200-01256	1	BRKT, MANUAL RESET T-STAT
18	200-01297	1	Bracket, Air heater wire retainer
19	72042	1	Screw, Type A #4x3/8" FH PH SS
20	343-00193	1	Harness, Air heater hi-limit

Parts Diagram and List (continued)

230-00123 Drain hose assembly

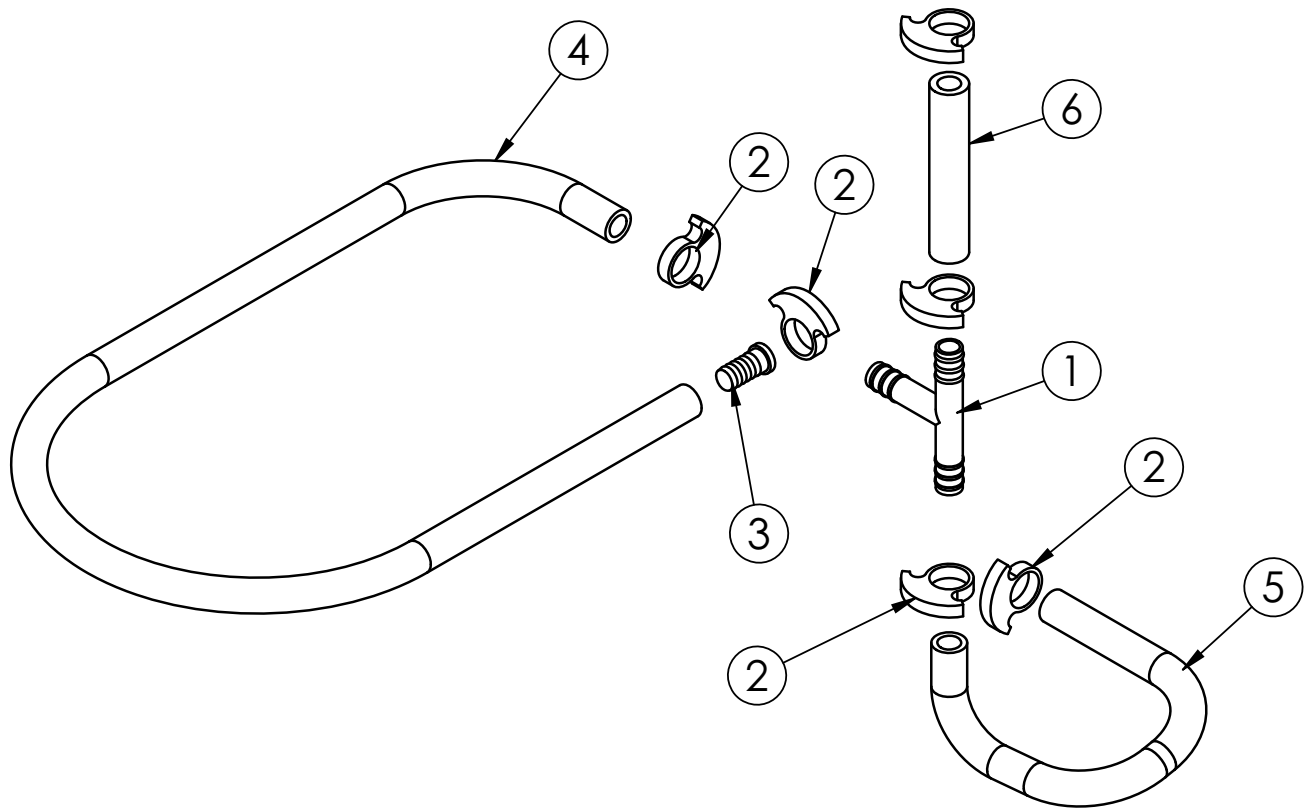

ITEM NO.	PART NUMBER	QTY.	DESCRIPTION
1	61152	1	TEE, 7/16 X 7/16 X 7/16 BARBED
2	07327	6	CLAMP, HOSE 21/32 ID
3	61232	1	PLUG, 3/8 BARBED SS
4	M326AL_Brewer drain tube	1	28" M326A tubing
5	M326AL_Brewer fill tube	1	Tubing, Brewer fill
6	326AL-Tank to Tee	1	3-1/4" M326A tubing

Parts Diagram and List (continued)

2503-006 Air heated shuttle assembly

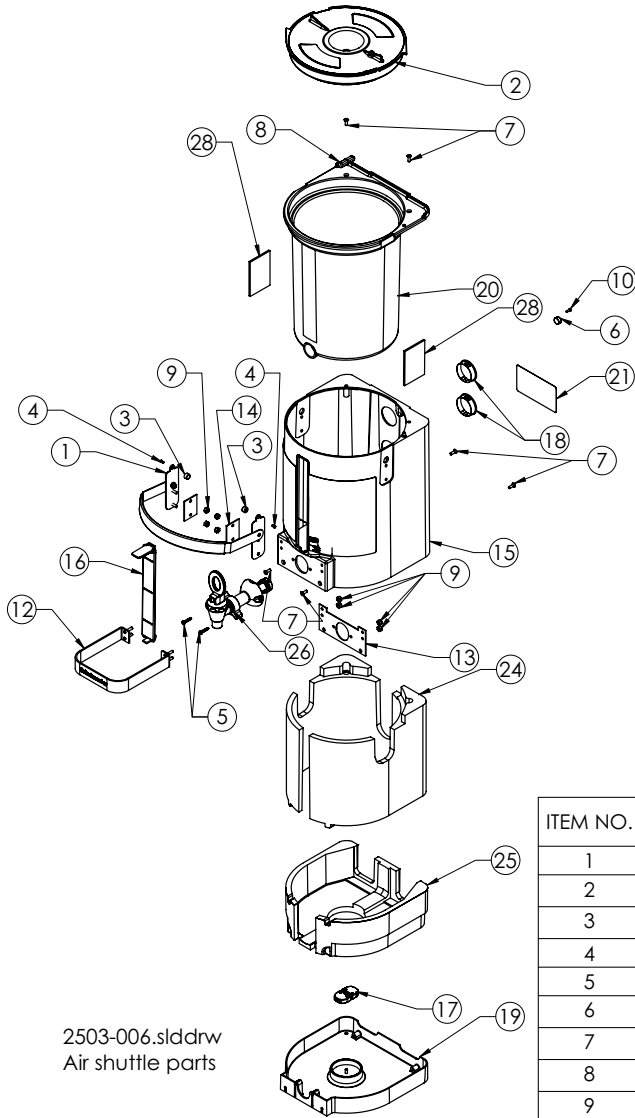

2503-006.slddrw
Air shuttle parts

ITEM NO.	PART NUMBER	2503-006/QTY.	DESCRIPTION
1	230-00136	1	HANDLE ASSEMBLY, SHUTTLE
2	230-00161	1	Shuttle cover assembly
3	210-00692	2	Stopper, Shuttle cover
4	350-00135	2	SCR, #4-40 X 1/4" PH FH MS SS
5	350-00083	2	SCREW, #6-19 X 3/4"L, HI-LO, PH PN HD
6	71499	1	Magnet, 1/2OD x 1/4W
7	72045	6	Scrw, #8 x 1/2" type B SS FHP
8	356-00040	1	Magnet, Stirrer
9	71261	8	NUT, 8-32 ESNA 18-8 SS
10	72042	1	Screw, Type A #4x3/8" FH PH SS
11	370-00015	4	Adhesive disc, 3/4" double sided
12	200-01086	1	Shuttle handle assembly
13	200-01081	1	Brace, Shuttle faucet
14	200-01080	2	Bracket, Shuttle handle
15	210-00527	1	Shuttle housing, air heated
16	210-00529	1	Lens, Shuttle front
17	230-00127	1	Magnet, Stirrer assembled
18	354-00013	2	Plug, Heyco #1316 clear
19	210-00530	1	Base, Shuttle molded
20	210-00474	1	Reservoir, Coffee shuttle
21	00800	1	TAG, SERIAL
22	380-00335	1	Wrap,Air heat shuttle
23	A92572	1	Decal, "warning" contents are...
24	322-00016	1	Insulation, Shuttle upper
25	322-00040	1	Insulation, Coated lower shuttle
26	280-00064	1	Faucet assy, without sightglass
27	230-00195	1	Packaging, Coffee Shuttle
28	W90155	2	3 inch

Parts Diagram and List (continued)

2503-007 Warmer shuttle assembly

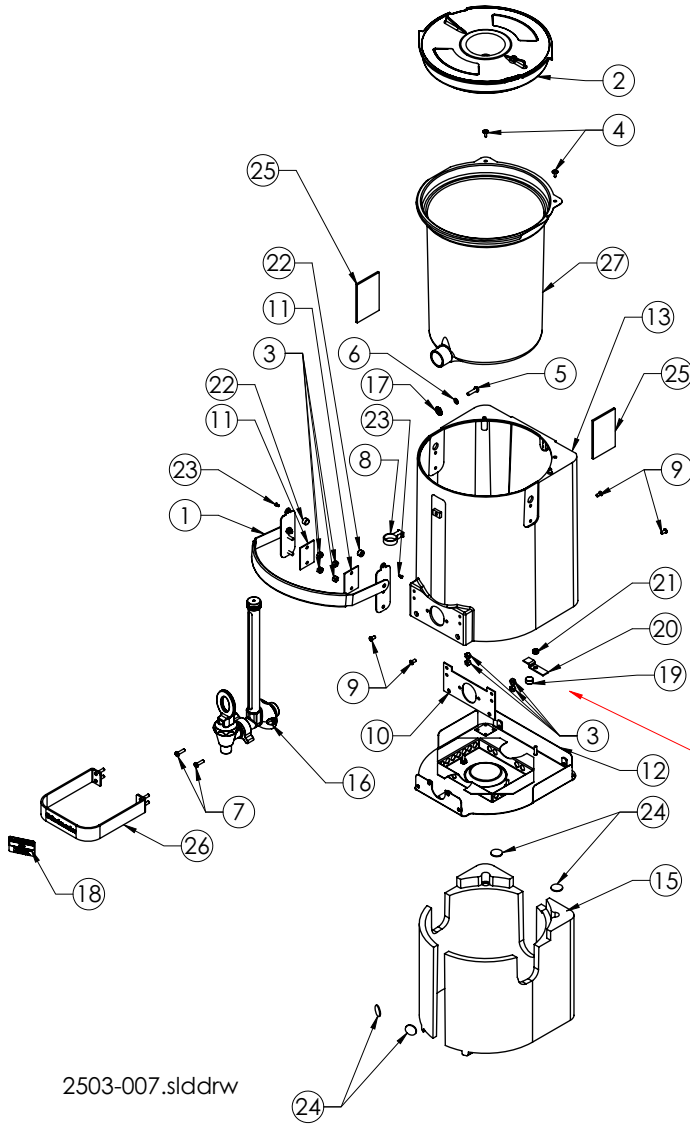

2503-007.slddrw

Assembly note:
Apply a Pea sized volume of RTV Silicone rubber between bracket and magnet to securely lock magnet in-place per magnet orientation fixture

ITEM NO.	PART NUMBER	2503-007	QTY.	DESCRIPTION
1	230-00136	1	1	HANDLE ASSEMBLY, SHUTTLE
2	230-00161	1	1	Shuttle cover assembly
3	71261	8	8	NUT, 8-32 ESNA 18-8 SS
4	70523	2	2	SCRW,#8x1/2 PN TR AB 410SS
5	0077	1	1	Screw, 10-24 x 3/4 SS PH PHD
6	07301-04	1	1	WASHER, #10 SAE FLAT
7	61305	2	2	SCR, #8-32 X 5/8 PH PN BLK SS
8	A522030D	1	1	BRACKET, SIGHT GLASS
9	71177	4	4	SCR, #8-32 X 3/8 PH FH UC
10	200-01081	1	1	Brace, Shuttle faucet
11	200-01080	2	2	Bracket, Shuttle handle
12	200-01088	1	1	SHUTTLE BASE ASSEMBLY, HEATED
13	210-00593	1	1	Housing, Sightglass chassis
14	00800	1	1	TAG, SERIAL
15	322-00016	1	1	Insulation, Shuttle upper
16	280-00070	1	1	Faucet assy, Sightglass
17	A603016	1	1	#10 INT/EXT PLATED LOCK WASHER
18	A92572	1	1	Decal, "warning" contents are...
19	220-00346	1	1	Magnet, 1/2OD x 1/4W coated
20	200-01183	1	1	Clamp, Magnet
21	71129	1	1	NUT, 8-32 KEPS SS
22	210-00692	2	2	Stopper, Shuttle cover
23	350-00135	2	2	SCR, #4-40 X 1/4" PH FH MS SS
24	370-00015	4	4	Adhesive disc, 3/4" double sided
25	W90155	2	2	3 inch
26	200-01086	1	1	Shuttle handle assembly
27	200-01114	1	1	Shuttle liner weldment, SS

Parts Diagram and List (continued)

Vacuum shuttles with and without stand

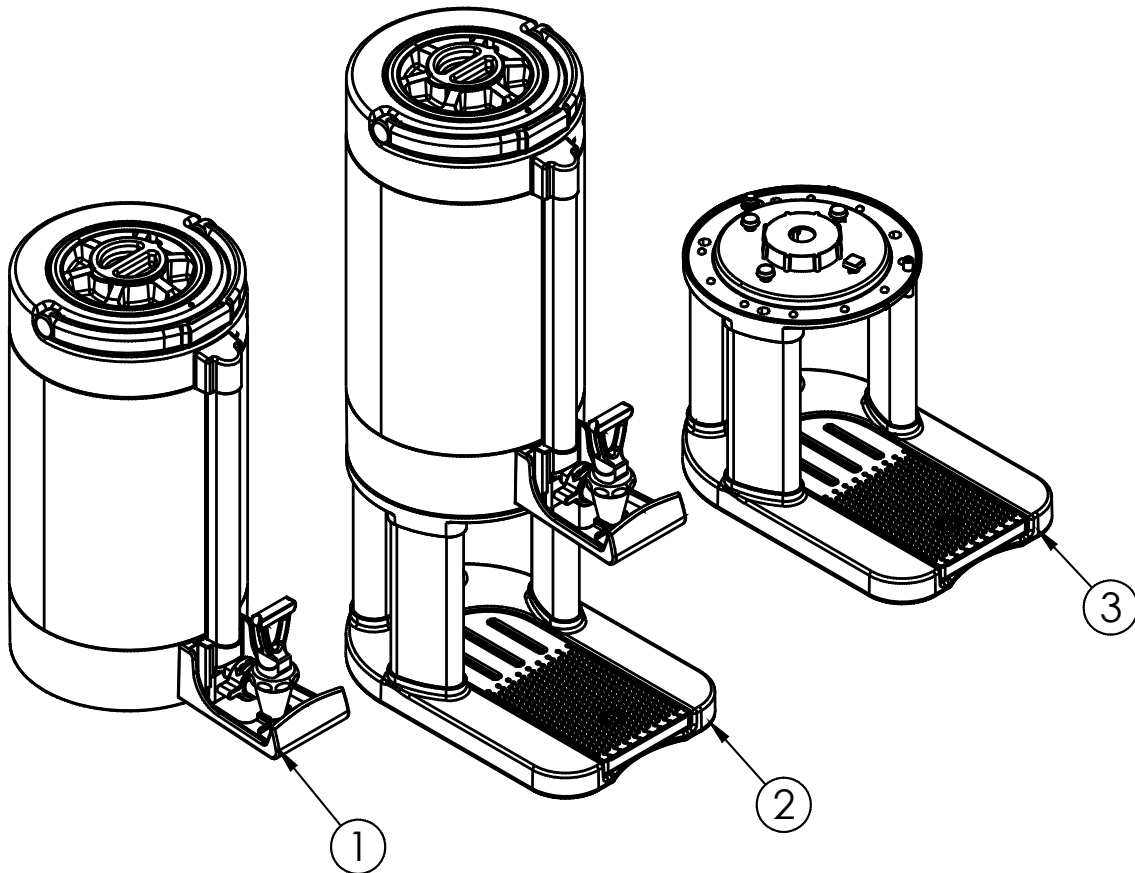

ITEM NO.	PART NUMBER	QTY.	DESCRIPTION
1	2503-001	1	Shuttle, 1.5 gal Vacuum
2	2503-002	1	Shuttle, 1.5 gal vacuum with stand
3	2503-003	1	Stand, 1.5 gal vacuum shuttle

Wiring Diagram (continued)

380-00369 Air heater controls

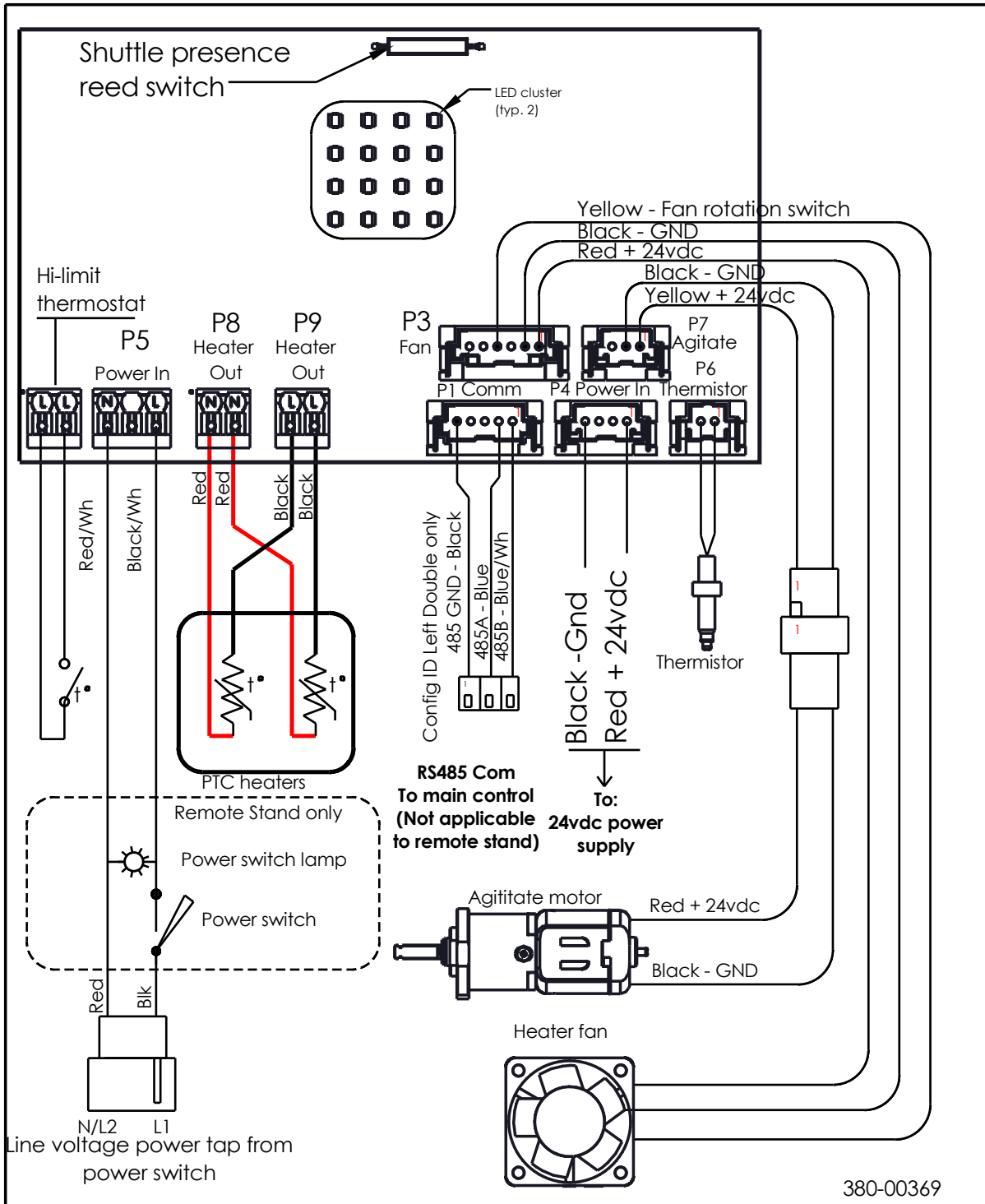

Grindmaster-Cecilware

4003 Collins Lane, Louisville, KY 40245 USA
Phone: 502.425.4776 Toll Free: 800.695.4500
Fax: 502.425.4664
Web: gmcw.com Email: info@gmcw.com

©2019 Grindmaster-Cecilware
Printed in USA



0219 Form # BW-341-01
Part # 390-00117