

OPERATOR MANUAL

IMPORTANT INFORMATION, KEEP FOR OPERATOR

This manual provides information for:

MODELS D SERIES: D, DT, DL, DLT & DISCONTINUED MODELS MW/D & MW/DT *Domestic* STEAM JACKETED KETTLE

- Stainless Steel
- Direct Steam Heated



**THIS MANUAL MUST BE RETAINED FOR FUTURE REFERENCE.
READ, UNDERSTAND AND FOLLOW THE INSTRUCTIONS AND
WARNINGS CONTAINED IN THIS MANUAL.**

FOR YOUR SAFETY

Do not store or use gasoline or other flammable vapors and liquids in the vicinity of this or any other appliance.

POST IN A PROMINENT LOCATION

Instructions to be followed in the event user smells gas. This information shall be obtained by consulting your local gas supplier. As a minimum, turn off the gas and call your gas company and your authorized service agent. Evacuate all personnel from the area.

WARNING

Improper installation, adjustment, alteration, service or maintenance can cause property damage, injury or death. Read the installation, operating and maintenance instructions thoroughly before installing or servicing this equipment.

NOTIFY CARRIER OF DAMAGE AT ONCE

It is the responsibility of the consignee to inspect the container upon receipt of same and to determine the possibility of any damage, including concealed damage. Unified Brands suggests that if you are suspicious of damage to make a notation on the delivery receipt. It will be the responsibility of the consignee to file a claim with the carrier. We recommend that you do so at once.

Manufacture Service/Questions 888-994-7636.

Information contained in this document is known to be current and accurate at the time of printing/creation. Unified Brands recommends referencing our product line websites, unifiedbrands.net, for the most updated product information and specifications.

PART NUMBER 121007, REV. D (10/12)

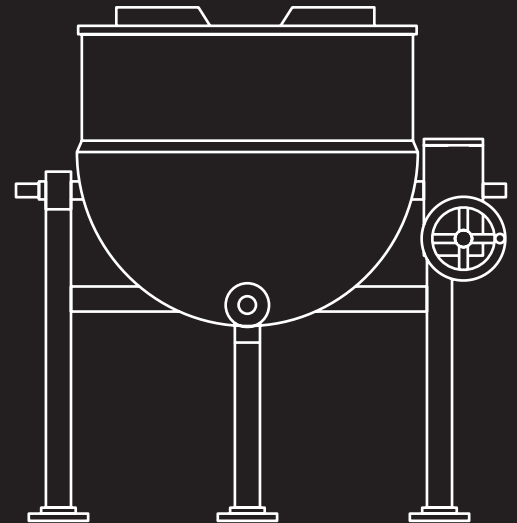

1055 Mendell Davis Drive
Jackson, MS 39272
888-994-7636, fax 888-864-7636
unifiedbrands.net

IMPORTANT - READ FIRST - IMPORTANT

- CAUTION:** BE SURE ALL OPERATORS READ, UNDERSTAND AND FOLLOW THE OPERATING INSTRUCTIONS, CAUTIONS, AND SAFETY INSTRUCTIONS CONTAINED IN THIS MANUAL.
- WARNING:** THIS UNIT IS INTENDED FOR USE IN THE COMMERCIAL HEATING, COOKING AND HOLDING OF WATER AND FOOD PRODUCTS, PER THE INSTRUCTIONS CONTAINED IN THIS MANUAL. ANY OTHER USE COULD RESULT IN SERIOUS PERSONAL INJURY OR DAMAGE TO THE EQUIPMENT AND WILL VOID WARRANTY.
- CAUTION:** SHIPPING STRAPS ARE UNDER TENSION AND CAN SNAP BACK WHEN CUT.
- CAUTION:** UNIT WEIGHS 190 TO 270 LBS (85 TO 125 KG). FOR SAFE HANDLING, INSTALLER SHOULD GET HELP AS NEEDED, OR USE MATERIALS HANDLING EQUIPMENT (E.G., FORK LIFT, DOLLY OR PALLET JACK) TO REMOVE THE UNIT FROM THE SKID AND MOVE IT TO THE PLACE OF INSTALLATION.
- WARNING:** KETTLES MUST BE INSTALLED BY PERSONNEL QUALIFIED TO WORK WITH PLUMBING. IMPROPER INSTALLATION CAN RESULT IN INJURY TO PERSONNEL AND/OR DAMAGE TO EQUIPMENT.
- WARNING:** AVOID ANY EXPOSURE TO ESCAPING STEAM. STEAM CAN CAUSE SEVERE BURNS.
- WARNING:** TAKE EXTREME CARE TO KEEP HOT CONTENTS FROM SPILLING OR SPLASHING ON ANYONE. DO NOT STAND DIRECTLY IN FRONT OF KETTLE BODIES WHEN THEY ARE BEING TILTED.
- WARNING:** AVOID ALL DIRECT CONTACT WITH HOT EQUIPMENT SURFACES. DIRECT SKIN CONTACT COULD RESULT IN SEVERE BURNS.
- WARNING:** AVOID ALL DIRECT CONTACT WITH HOT FOOD OR WATER IN KETTLES. DIRECT CONTACT COULD RESULT IN SEVERE BURNS.
- CAUTION:** DO NOT OVER FILL THE KETTLE WHEN COOKING, HOLDING OR CLEANING. KEEP LIQUIDS A MINIMUM OF 2-3" (5-8 CM) BELOW THE KETTLE BODY RIM TO ALLOW CLEARANCE FOR STIRRING, BOILING AND SAFE PRODUCT TRANSFER.
- WARNING:** TAKE SPECIAL CARE TO AVOID CONTACT WITH HOT KETTLE BODY OR HOT PRODUCT WHEN ADDING INGREDIENTS, STIRRING OR TRANSFERRING PRODUCT TO ANOTHER CONTAINER.
- WARNING:** WHEN TILTING KETTLE FOR PRODUCT TRANSFER:
- 1) WEAR PROTECTIVE OVEN MITT AND PROTECTIVE APRON.
 - 2) USE CONTAINER DEEP ENOUGH TO CONTAIN AND MINIMIZE PRODUCT SPLASHING.
 - 3) PLACE CONTAINER ON STABLE, FLAT SURFACE, AS CLOSE TO KETTLE AS POSSIBLE.
 - 4) STAND TO LEFT OR RIGHT SIDE OF KETTLE (DEPENDING ON TILTING HANDLE PLACEMENT) WHILE POURING. DO NOT STAND DIRECTLY IN POUR PATH OF HOT CONTENTS.
 - 5) POUR SLOWLY, MAINTAIN CONTROL OF KETTLE BODY HANDLE AT ALL TIMES, AND RETURN KETTLE BODY TO UPRIGHT POSITION AFTER CONTAINER IS FILLED OR TRANSFER IS COMPLETE.
 - 6) DO NOT OVERFILL CONTAINER. AVOID DIRECT SKIN CONTACT WITH HOT CONTAINER AND ITS CONTENTS.
- CAUTION:** KEEP FLOORS IN FRONT OF KETTLE WORK AREA CLEAN AND DRY. IF SPILLS OCCUR, CLEAN IMMEDIATELY, TO AVOID SLIPS OR FALLS.
- WARNING:** FAILURE TO CHECK SAFETY VALVE OPERATION PERIODICALLY COULD RESULT IN PERSONAL INJURY AND/OR DAMAGE TO EQUIPMENT.
- WARNING:** WHEN TESTING, AVOID ANY EXPOSURE TO THE STEAM BLOWING OUT OF THE SAFETY VALVE. DIRECT CONTACT COULD RESULT IN SEVERE BURNS.

IMPORTANT - READ FIRST - IMPORTANT

WARNING: TO AVOID INJURY, READ AND FOLLOW ALL PRECAUTIONS STATED ON THE LABEL OF THE WATER TREATMENT COMPOUND.

CAUTION: MOST CLEANERS ARE HARMFUL TO THE SKIN, EYES, MUCOUS MEMBRANES AND CLOTHING. PRECAUTIONS SHOULD BE TAKEN. WEAR RUBBER GLOVES, GOGGLES OR FACE SHIELD AND PROTECTIVE CLOTHING. CAREFULLY READ THE WARNINGS AND FOLLOW THE DIRECTIONS ON THE LABEL OF THE CLEANER TO BE USED.

CAUTION: USE OF ANY REPLACEMENT PARTS OTHER THAN THOSE SUPPLIED BY GROEN OR ITS AUTHORIZED DISTRIBUTORS CAN CAUSE OPERATOR INJURY AND DAMAGE TO THE EQUIPMENT, AND WILL VOID ALL WARRANTIES.

IMPORTANT: SERVICE PERFORMED BY OTHER THAN FACTORY AUTHORIZED PERSONNEL WILL VOID WARRANTIES.

Table of Contents

Important Operator Warnings	page 2-3
References	page 4
Equipment Description	page 5
Inspection & Unpacking	page 6
Installation	page 7
Initial Start-Up	page 8
Operation	page 9
Cleaning	page 10-11
Maintenance	page 12
Sequence of Operation	page 13
Troubleshooting	page 14
Parts List	page 15-18
Bucket Steam Trap	page 19
Installation Diagram Chair for Wall Mount Kettles	page 20
Service Log	page 21

References

KLENZADE SALES CENTER
ECOLAB. Inc.
370 Wabasha
St. Paul, Minnesota 55102
800/352-5326 or 612/293-2233

NSF INTERNATIONAL
798 N. Dixboro Rd.
P.O. Box 130140
Ann Arbor, Michigan 48113-0140

ZEP MANUFACTURING CO.
1310-T Seaboard Industrial Blvd.
Atlanta, Georgia 30318

Equipment Description

STANDARD CAPACITIES, GALLONS					
Model	20	40	60	80	100
D	•	•	•		
DT	•	•			
DL, DLT	•	•	•	•	
MW/D, MW/DT	•	•	•	•	•

OPTIONAL DRAW-OFFS AVAILABLE*			
Model	1-1/2"	2"	3"
DT (20 or 40 Gallon)	•	•	
DLT (All Sizes)	•	•	
MW/DT (All Sizes)	•	•	•

*2" or 3" ONLY provided on current production.



The Groen D Series are deep type, tilting kettles with direct steam-heated 2/3 jackets. The stainless steel kettles have welded, reinforced rims and butterfly shaped pouring lips. The liner and pouring lip of all kettles are 316 stainless steel. They are ASME shop-inspected, and are registered with the National Board. The kettles have a 180 emery grit interior finish and a bright semi-deluxe exterior finish.

Every unit requires a remote steam source. The steam supply is controlled by an inlet valve, and enters the jacket through one trunnion directly into the jacket. Steam pressure forces condensate out a dip tube through the other trunnion. Both steam and condensate lines are concealed within the support structures of the various models. The table to the left shows the standard kettle sizes for each model.

These kettles operate safely and efficiently at various steam pressures above five PSI, with upper pressure limits assured by the provided safety valve. Operation also requires a globe valve on the steam inlet and a strainer, steam trap, and check valve on the condensate outlet. These may be ordered from Groen as optional equipment.

D Series kettles are emptied by tilting, but optional tangent draw-offs are available. The standard draw-off is two inch outer diameter stainless steel, with compression disc valve and a removable stainless steel strainer that has 1/4 inch perforations. Strainers with 1/8 inch or no perforations are also available. The table on the left shows the sizes of draw-offs which can be furnished with each model. When equipped with a tangent draw-off the designation "T" is added to the model designation.

The kettles in this series employ a worm and gear tilting mechanism, which is completely enclosed.

D Series kettles are mounted in three ways. Model D is suspended in a stainless steel yoke on a pedestal base. The outer circumference of the base is flanged down for proper sealing to the floor. Model DL is supported by a tubular, stainless steel tri-leg frame with adjustable floor flanges. The discontinued wall-mounted model MW/D had a supporting frame enclosed in a stainless steel, drip-proof housing. The frame hung on an in-wall carrier which was purchased as an option.

Other options include:

1. No. 31 lift-off cover (for kettles smaller than 60 gallons)
2. No. 51 cover with counter-balancing actuator (for 40 gallon and larger kettles)
3. Fill faucets with swing spout
4. Gallon Master water meter
5. TRI-BC basket cooking system
6. Kettle brush kit
7. Operating pressures up to 90 PSIG

Inspection & Unpacking

CAUTION

SHIPPING STRAPS ARE UNDER TENSION AND CAN SNAP BACK WHEN CUT. AVOID NAILS AND SPLINTERS WHEN REMOVING KETTLES FROM WOODEN CRATES. WEAR SAFETY GLASSES.

CAUTION

UNIT WEIGHS 215 TO 295 LBS (98 TO 134 KG). FOR SAFE HANDLING, INSTALLER SHOULD GET HELP AS NEEDED, OR USE MATERIALS HANDLING EQUIPMENT (e.g., FORK LIFT, DOLLY OR PALLET JACK) TO REMOVE THE UNIT FROM THE SKID AND PLACE IT FOR INSTALLATION.

The kettle will arrive completely assembled and wrapped in protective plastic, strapped and bolted on a heavy skid, enclosed in a crate. Immediately on receipt remove the box and plastic wrap, and inspect the unit for damage. Report any damage or an incorrect shipment to the delivery agent.

Write down the model number, serial number and installation date, and keep this information for future reference. Space for these entries is provided at the top of the Service Log in the back of this manual.

When installation is to begin, cut the straps holding the unit on the skid. Lift the unit straight up off of the skid.

Installation

WARNING
THIS UNIT MUST BE INSTALLED BY PERSONNEL QUALIFIED TO WORK WITH PLUMBING. IMPROPER INSTALLATION CAN CAUSE INJURY TO PERSONNEL AND/OR DAMAGE TO EQUIPMENT.

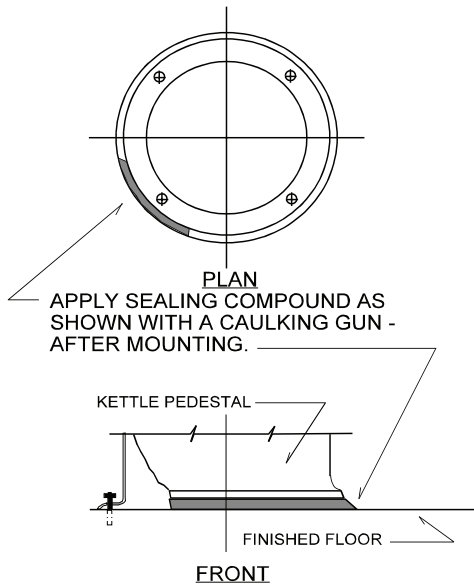

For proper sanitation, continuous seal is required between pedestals or flanges and the mounting surface.

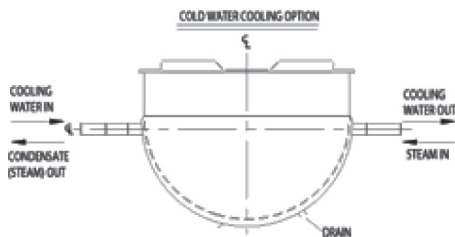

1. Installation under a ventilation hood is recommended. Consult local codes.
2. Install and anchor the kettle on a level surface.
3. If the steam supply pressure is greater than the maximum working pressure stamped on the nameplate, you must install a pressure reducing valve in the steam supply line near the kettle.
4. Connect the steam supply line to the steam inlet fitting. Include a steam control valve and an appropriate safety valve. To obtain the full heating capability of the kettle, the steam supply line must be as large as the steam inlet fitting.
5. The safety valve is preset to relieve jacket pressure that exceeds its rated limit. Do not try to adjust the valve setting, and do not allow the valve outlet or lever to be blocked.
6. Connect the kettle condensate return line to the boiler return line, or to a drain. A suitable steam trap, strainer, and check valve must be installed on the left side kettle trunnion (viewed from the front). (See piping diagram, Page 19).
7. Any mechanical change must be approved by the Groen Food Service Engineering Department.

FLOOR MOUNTED MODELS ONLY:

1. Install the unit on a level surface. Ensure that there is adequate clearance at the sides and rear, as required by the specification drawings. Anchor the pedestal or legs securely to the floor.
2. Apply a continuous bead of clear silicone sealant (No. 732 or equivalent) to the junction between the pedestal or leg flange and the surface, as shown in the illustration at left. Fill all cracks and crevices, and wipe excess away.

COLD WATER COOLING OPTION: See image at left.

DISCONTINUED WALL MOUNTED MODELS ONLY:

1. Install a “chair carrier” in the wall to which the unit will be attached, following the instructions pertaining to anchoring and location. See diagram on page 20.
2. Stub in the steam supply line and condensate return line so that they will be aligned with the appropriate fittings when the unit is mounted.
3. Mount the unit on the protruding studs of the chair carrier.
4. Apply a continuous bead of clear silicone sealant (No. 732 or equivalent) to the junction between the frame housing and the wall. Fill all cracks and crevices, and wipe away the excess.

Initial Start-Up

IMPORTANT
BE SURE ALL OPERATORS READ,
UNDERSTAND AND FOLLOW THE
OPERATING INSTRUCTIONS, CAUTIONS
AND SAFETY INSTRUCTIONS CONTAINED
IN THIS MANUAL.

WARNING
AVOID ANY EXPOSURE TO ESCAPING
STEAM, WHICH CAN CAUSE SEVERE BURNS.



Now that the kettle has been installed, you should test it to ensure that it is operating correctly.

1. Remove all literature and packing materials from inside and outside of the unit. Clean out any material that might clog the tangent draw-off valve, if present.
2. Pour a small amount of water into the kettle.
3. Open the steam inlet valve.
4. When the water begins to boil, inspect all of the fittings to ensure that there are no leaks.
5. Check the safety valve by lifting its lever far enough to let steam escape. Then let it snap back into place to reseat the valve so that it will not leak.
6. Shut down the unit by closing the steam inlet valve.
7. Operate the tilting mechanism and draw-off valve to confirm that they function through the whole range of normal operation.

If the unit functions as described above, it is ready for use. If the unit does not function as intended, contact your local Groen Certified Service Agency.

Operation

WARNING
AVOID EXPOSURE TO ESCAPING STEAM,
WHICH CAN CAUSE SEVERE BURNS.

CAUTION
DO NOT OVERFILL THE KETTLE WHEN
COOKING, HOLDING OR CLEANING. KEEP
LIQUIDS AT LEAST 2-3" (5-8 cm) BELOW
THE KETTLE BODY RIM TO ALLOW
CLEARANCE FOR STIRRING, BOILING
PRODUCT AND SAFE TRANSFER.

WARNING
WHEN TILTING KETTLE FOR PRODUCT
FOR PRODUCT TRANSFER:

- 1) WEAR PROTECTIVE OVEN MITT AND PROTECTIVE APRON.
- 2) USE CONTAINER DEEP ENOUGH TO CONTAIN AND MINIMIZE PRODUCT SPLASHING.
- 3) PLACE CONTAINER ON STABLE, FLAT SURFACE, AS CLOSE TO KETTLE AS POSSIBLE.
- 4) STAND TO LEFT OR RIGHT SIDE OF KETTLE WHILE POURING – NOT DIRECTLY IN POUR PATH OF HOT CONTENTS.
- 5) POUR SLOWLY, MAINTAIN CONTROL OF KETTLE AT ALL TIMES, AND RETURN KETTLE BODY TO UPRIGHT POSITION AFTER CONTAINER IS FILLED OR TRANSFER IS COMPLETE.
- 6) DO NOT OVERFILL CONTAINER. AVOID DIRECT SKIN CONTACT WITH HOT CONTAINER AND ITS CONTENTS.

WARNING
AVOID ALL DIRECT CONTACT WITH
HOT FOOD OR WATER IN THE KETTLE.
DIRECT CONTACT COULD RESULT IN
SEVERE BURNS. TAKE CARE TO AVOID
CONTACT WITH HOT KETTLE BODY OR HOT
PRODUCT. WHEN ADDING INGREDIENTS,
STIRRING OR TRANSFERRING PRODUCT
TO ANOTHER CONTAINER.



Before operating a cold kettle, open the petcock at the bottom of the jacket to drain any water left by condensing steam. Close the petcock before you open the steam inlet valve. Draining this water decreases the “hammering” you hear when steam enters a cold jacket.

To heat the kettle, open the steam inlet valve. Adjusting the inlet valve allows the operator to control the heating rate. Opening the valve more allows steam to flow into the jacket faster, and thereby heats the product faster.

The kettle operates efficiently with steam pressures from five PSI to the maximum working pressure for which the kettle was designed. The maximum allowable pressure is stamped on the kettle nameplate. It is 25 PSI for standard units.

Once a day, while there is still steam pressure in the jacket, bleed off any entrapped air and double check the operation of the safety valve. Pull out on its chain, or lift the lever far enough to let steam escape. Then let it snap back into place to reseal the valve so that it will not leak.

TILTING THE KETTLE:

To transfer product or empty the kettle: turn the handwheel counterclockwise. The kettle will hold its position when you stop turning the wheel. If the tilting mechanism seems to be locked, do not use force to free the kettle. Call for assistance from your Groen Certified Service Agency, or refer to the Troubleshooting section of this manual.

OPTIONAL COLD WATER COOLING: (Reference Typical Piping Arrangement Drawings)

Sequence of Operation for Heating

1. Close Water Inlet Valve, Kettle Drain Valve, and Water Outlet Valve
2. Open Condensate Outlet Valve
3. Open Steam Inlet Valve

Sequence of Operation for Cooling

1. Close Steam Inlet Valve and Condensate Outlet Valve
2. Open Water Outlet Valve
3. Open Water Inlet Valve

Sequence of Operation for Heating after Cooling

1. Close Water Inlet Valve and Water Outlet Valve
2. Open Kettle Drain Valve until jacket is empty
3. Open Condensate Outlet Valve
4. Open Steam Inlet Valve

Cleaning

CAUTION

NEVER LEAVE A CHLORINE SANITIZER IN CONTACT WITH STAINLESS STEEL SURFACES FOR LONGER THAN 30 MINUTES. LONGER CONTACT CAN CAUSE CORROSION.

CAUTION

MOST CLEANERS ARE HARMFUL TO THE SKIN, EYES, MUCOUS MEMBRANES AND CLOTHING. PRECAUTIONS SHOULD BE TAKEN TO WEAR RUBBER GLOVES, GOGGLES OR FACE SHIELD AND PROTECTIVE CLOTHING. CAREFULLY READ THE WARNINGS AND FOLLOW LABEL DIRECTIONS.



A. Suggested Cleaning Supplies

1. A high quality detergent and sanitizer, or a combination cleaning-sanitizing agent.
2. Kettle brushes in good condition.
3. Brush suitable for cleaning the tangent draw-off port (if kettle has optional tangent).
4. Use a good sanitizer
5. Film remover

B. Procedure

1. Clean food-contact surfaces as soon as possible after use. If the unit is in continuous use, thoroughly clean and sanitize the interior and exterior at least once every 12 hours.
2. Scrape and flush out food residues. Be careful not to scratch the kettle with metal implements.
3. Prepare a hot solution of the detergent/ cleaning compound as instructed by the supplier.
4. Clean the unit thoroughly, inside and outside.
5. Rinse the kettle thoroughly with hot water, then drain completely.
6. As part of the daily cleaning program, clean soiled external and internal surfaces.
7. To remove stuck materials, use a brush, sponge, cloth, plastic or rubber scraper, or plastic wool with the cleaning solution. To reduce effort required in washing, let the detergent solution sit in the kettle and soak into the residue. Do not use abrasive materials or metal tools that might scratch the surface. Scratches make the surface harder to clean and provide places for bacteria to grow. Do not use steel wool, which may leave particles in the surface and cause eventual corrosion and pitting.
8. The outside of the unit maybe polished with a stainless steel cleaner such as "Zepper" from Zep Manufacturing Co.
9. When equipment needs to be sanitized, use a solution equivalent to one that supplies 200 parts per million available chlorine. Obtain advice on sanitizing agents from your supplier of sanitizing products. Following the supplier's instructions, apply the agent after the unit has been cleaned and drained. Drain and thoroughly rinse off the sanitizer.
10. It is recommended that each piece of equipment be sanitized just before use.
11. If there is difficulty removing mineral deposits or a film left by hard water or food residues, clean the kettle thoroughly and use a deliming agent, like Groen Delimer/Descaler (Part Number [114800](#)), in accordance with the manufacturer's directions. Rinse and drain the unit thoroughly before further use.

Cleaning

CAUTION
NEVER LEAVE A CHLORINE SANITIZER
IN CONTACT WITH STAINLESS STEEL
SURFACES FOR LONGER THAN 30
MINUTES. LONGER CONTACT CAN
CAUSE CORROSION.



Use a brush, sponge, cloth, plastic or rubber scraper, or plastic wool to clean.



Don't use metal implements or steel wool when cleaning.

12. If cleaning problems persist, contact your cleaning product representative for assistance. The supplier has a trained technical staff with laboratory facilities to serve you.

13. If your unit is equipped with a tangent draw-off valve, disassemble it and clean the draw-off port and each valve part with a brush.

NOTICE: DO NOT MIX THE PARTS OF DIFFERENT DRAW-OFF ASSEMBLIES WHEN CLEANING. THE PARTS ARE NOT INTERCHANGEABLE.

Maintenance

WARNING

WHEN USING THE EQUIPMENT OR TESTING, AVOID ANY EXPOSURE TO THE STEAM BLOWING OUT OF THE SAFETY VALVE. SEVERE BURNS CAN RESULT ON EXPOSED SKIN. FAILURE TO CHECK SAFETY VALVE OPERATION PERIODICALLY COULD RESULT IN PERSONAL INJURY AND/OR DAMAGE TO EQUIPMENT.

CAUTION

USE OF ANY REPLACEMENT PARTS OTHER THAN THOSE SUPPLIED BY GROEN OR AN AUTHORIZED SUPPLIER WILL VOID ALL WARRANTIES AND COULD INJURE THE OPERATOR OR DAMAGE THE EQUIPMENT.



NOTICE: Contact an authorized representative when repairs are required.

PERIODIC MAINTENANCE

A Maintenance & Service Log is provided at the back of this manual with the warranty information. Each time maintenance is performed on your Groen kettle, enter the date on which the work was done, what was done, and who did it. File the log with the warranty.

Periodic inspection will minimize equipment down time and increase the efficiency of operation. The following points should be checked:

1. Once a day, with pressure in the jacket, check the operation of the safety valve. Lift the lever of the safety valve until steam is released. Then release the lever and let the valve snap shut. If the lever does not activate, or there is no evidence of discharge, or the valve leaks, immediately discontinue use of the kettle and contact a qualified Groen service representative.
2. At least once every 90 days, inspect fittings and valves for signs of damage or wear. Regularly examine trunnion packings and valve seats for wear, and replace them when necessary.

NOTE: Service performed by other than factory authorized personnel will void all warranties.

3. Lubricate trunnions and gears with a good grade of high temperature grease. Grease trunnions at least once every 60 days, and grease gears when inspection shows that they are dry.
4. If the kettle cover has an actuator, lubricate it every 90 days.

NOTE: Use only Calcium Complex Nr. 2 Grease, which is available from Groen (Part No. [093703](#)).

Sequence of Operation

The following “action-reaction” outline is provided to help the user understand the function of the equipment.

When the steam inlet valve is opened, steam flows into the jacket at a pressure determined by the boiler system or by the pressure reducing valve that serves the kettle.

In the jacket, steam transfers heat to the kettle as it condenses into water. The steam trap allows condensate (water) to leave the jacket, while it holds steam in. When the steam is shut off, condensation produces a vacuum in the jacket, but the check valve in the condensate return line keeps water from flowing back into the jacket.

Troubleshooting

Your Groen kettle will operate smoothly and efficiently if properly maintained. However, the following is a list of checks to make in the event of a problem. If the actions suggested do not solve the problem, call your qualified Groen Service Representative. For the phone number of the nearest agency, call your area Groen representative or the Groen Parts and Service Department. If an item on the list is followed by an X, the work should be done by a qualified service representative.

WARNING

USE OF ANY REPLACEMENT PARTS OTHER THAN THOSE SUPPLIED BY GROEN OR THEIR AUTHORIZED DISTRIBUTORS CAN CAUSE INJURY TO THE OPERATOR AND DAMAGE TO THE EQUIPMENT AND WILL VOID ALL WARRANTIES.

TO AVOID INJURY FROM SPLASHING OR SPILLING HOT CONTENTS, EMPTY THE KETTLE THROUGH THE DRAW-OFF OR BY BAILING BEFORE ANY WORK IS DONE ON THE TILTING MECHANISM.

SYMPTOM	WHO	WHAT TO CHECK <small>X indicates items which must be performed by an authorized technician.</small>
Kettle will not heat.	User	a. That the steam inlet valve is open. b. That the steam supply line is turned on. c. That the condensate return valve is open. d. That the boiler is operating properly. Steam should be supplied at a pressure greater than five PSI.
	Auth Service Rep Only	e. Steam supply line for blockage. X f. Condensate return line for blockage. X g. Steam trap operation. X
Safety valve leaks a small amount of steam.	User	a. For contamination that prevents seating the valve. With substantial pressure in the jacket, lift the valve lever briefly all the way up, to blow the valve clean then let it snap back down to seat the valve.
	Auth Service Rep Only	b. Safety valve for defects. Defective valve MUST be replaced with an identical valve. X
Safety valve leaks a large amount of steam.	Auth Service Rep Only	a. Steam supply pressure. X b. Safety valve for defects. Defective valve MUST be replaced with an identical valve. X
Pipe fitting leaks.	User	a. Is the fitting tight?
	Auth Service Rep Only	b. If the leak is at a trunnion, and tightening the packing gland does not stop the leak, replace the packing. X
Kettle is hard to tilt.	Auth Service Rep Only	a. Tilting gear and worm for the presence of any contamination and for proper alignment and lubrication. X
Kettle makes a banging noise when steam is turned on.	User	Drain water from the jacket by opening the petcock at the bottom of the kettle before admitting steam into the jacket. Close the petcock before opening the steam valve.

Parts List

Key	Description	Part No.
1	GEAR, WORM - D-20-40-60-80	012022
2	STEAM GLAND - D-20-40-60-80	012120
3	PACKING, 10 RING - D-20-40-60-80	114824
4	NUT, PACKING - D-20-40-60-80	012122
5	ENCLOS. TILT MECH. D-20-40-60-80	139043
6	GREASE FITTING, 90 DEG.	012195
7	CARRIER ASSY GEAR D-20-40-60-80	137880
8	SAFETY VALVE (CAUTION: PRESSURE AND FLOW RATE OF REPLACEMENT VALVE MUST BE THE SAME AS ORIGINALLY PROVIDED.)	
-	3/4" SAFETY VALVE (50 PSIG)	005587
-	1/2" SAFETY VALVE (50 PSIG)	097005
9	TEE, CHROME PLATED, 3/4 NPT	012075
10	LOCKWASHER, 3/8"	005618
11	SCREW CAP HEX 3/8-16 X 3/4	005611
12	BEARING, ROLLER	002790
13	WORM	12026
14	SHAFT	003129
15	HANDWHEEL WITH HANDLE	139152
16	HANDWHEEL SHAFT	003130
17	COLLAR	137246
18	GREASE FITTING, 45 DEG	012099
19	CASTING TRUNNION RACE- 20-40-60-80	012113
20	DRAW-OFF VALVE, 2" (COMPLETE)	009046
-	DRAW-OFF VALVE, 3" (COMPLETE)	012262
-	HANDLE FOR 2" TDO VALVE	009029
-	HANDLE FOR 3" TDO VALVE	012209
-	STEM FOR 2" VALVE	009048
-	STEM FOR 3" VALVE	001908
-	WING NUT FOR 2" VALVES	009028
-	BONNET FOR 2"	009047
-	BONNET FOR 3"	003925
-	HEX NUT FOR 2"	009354
-	HEX NUT FOR 3"	003927
21	PETCOCK, JACKET DRAIN	012070
22	STAND ASSEMBLY (CALL GROEN FOR PART NO.)	

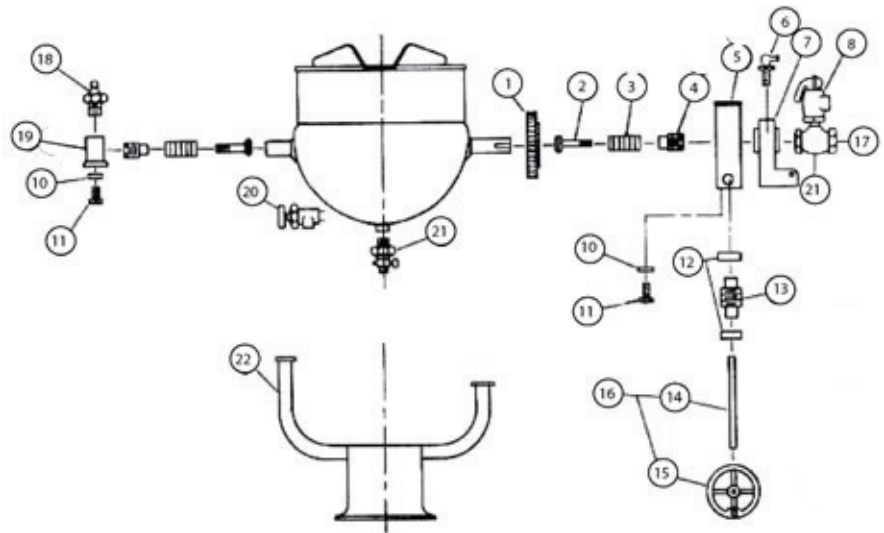

Models D, DT DL and DLT (after May 2002)

Parts List

Key	Description	Part No.
1	GEAR, WORM - D-10 -20 -30	012023
2	GEAR, WORM - D-40 -60 -80	012022
3	STEAM GLAND - D-10 -20 -30	012227
4	STEAM GLAND - D-40 -60 -80	012120
5	PACKING, 6 RING - D-10 -20 -30	012230
6	PACKING, 6 RING - D-40 -60 -80	114824
7	NUT, PACKING - D-10 -20 -30	012228
8	NUT, PACKING - D-40 -60 -80	012122
9	ENCLOS. TILT MECH. D-10 -20 -30	014075
10	ENCLOS. TILT MECH. D-40 -60 -80	014076
11	GREASE FITTING, 90 DEG.	012195
12	CARRIER ASSY, GEAR D-10 -20 -30	014077
13	CARRIER ASSY GEAR D-40 -60 -80	014079
14	SAFETY VALVE (CAUTION: PRESSURE AND FLOW RATE OF REPLACEMENT VALVE MUST BE THE SAME AS ORIGINALLY PROVIDED)	
-	¾" SAFETY VALVE	005587
-	½" SAFETY VALVE	097005
15	TEE, CHROME PLATED, ¾ NPT	012075
16	LOCKWASHER, 3/8"	005618
17	SCREW CAP HEX 3/8-16 X 3/4	005611
18	BEARING, ROLLER	002790
19	WORM	012026
20	SHAFT	003129
21	HANDWHEEL WITH HANDLE	012061
22	HANDWHEEL & SHAFT (COMPLETE)	003130
23	GREASE FITTING, 45 DEG	012099
24	CASTING TRUNNION RACE- D-10 -20 -30	012109
25	CASTING TRUNNION RACE - D-40 -60 -80	012113
26	DRAW-O VALVE, DAIRY 1½" (COMPLETE)	009000
-	DRAW-O VALVE, DAIRY, 2" (COMPLETE)	009046
-	DRAW-O VALVE, DAIRY, 3" (COMPLETE)	012262
-	HANDLE FOR 1½" OR 2" DAIRY VALVE	009029
-	HANDLE FOR 3" DAIRY VALVE	012209
-	STEM FOR 1½" VALVE	009027

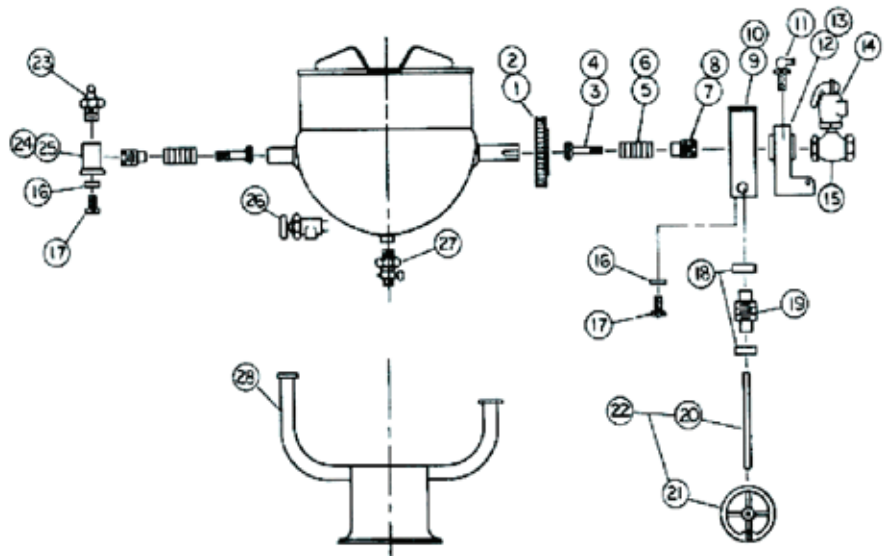

Models D, DT, DL and DLT (January 1974 - May 2002)

-	STEM FOR 2" VALVE	009048
-	STEM FOR 3" VALVE	001908
-	WING NUT (WITH 001908)	-
-	WING NUT FOR 1½" AND 2" VALVES	009028
-	DRAW-O VALVE, PLUG, NEW STYLE, 1½"	009737
-	DRAW-O VALVE, PLUG, OLD STYLE, 1½"	009734
-	DRAW-O VALVE, PLUG, OLD STYLE, 2"	009735
27	PETCOCK, JACKET DRAIN	012070
-	BONNET FOR 1½"	009024
-	BONNET FOR 2"	009047
-	BONNET FOR 3"	003925
-	HEX NUT FOR 1½"	008911
-	HEX NUT FOR 2"	009354
-	HEX NUT FOR 3"	003927
28	STAND ASSEMBLY (CALL GROEN FOR PART NO.)	

Parts List

Key	Description	Part No.
1	STEAM GLAND 10-20-30 PRE-FEB 1961	001235
2	STEAM GLAND 40-60-80 PRE-FEB 1961	001211
3	PACKING	001234
4	PACKING GLAND 10-20-30 PRE-FEB 1961	001231
5	PACKING GLAND 40-60-80 PRE-FEB 1961	001236
6	TRUNNION NUT 10-20-30 PRE-FEB 1961	001232
7	TRUNNION NUT 40-60-80 PRE-FEB 1961	001237
8	7½" D. WORM GEAR 1-5/8" BORE 1947-51	012064
9	7½" D. WORM GEAR 2" BORE 1947-51	012063
10	GEAR HOUSING 1-5/8" HOLE - SPECIAL ORDER	012107
11	GEAR HOUSING 2" HOLE - SPECIAL ORDER	012111
12	GEAR HOUSING COVER (1¾" HOLE)	012050
13	GEAR HOUSING COVER (2-1/8" HOLE)	012051
14	NO. 10-24 X ½" ROUND HEAD SS SCREW	012065
15	ALEMITE GREASE FITTING (STRAIGHT)	012100
16	TRUNNION RACE (1-5/8" HOLE)	012109
17	TRUNNION RACE (2" HOLE)	012113
18	3/8 LOCKWASHER	005618
19	3/8 - 16 N.C. X ¾" LONG HEX CAP SCREW	005611
20	STEAM GLAND (1-5/8" TRUNNION)	012227
21	STEAM GLAND (2" TRUNNION)	012120
22	PACKING (7-RING)(1-5/8" TRUNNION)	012230
23	PACKING (7-RING)(2" TRUNNION)	002424
24	1-5/16" O.D. PACKING NUT	012228
25	1-5/8" O.D. PACKING NUT	012122
26	8½" DIA. WORM GEAR (1-5/8" BORE)	012023
27	8½" DIA. WORM GEAR (2" BORE)	012022
28	45° ALEMITE GREASE FITTING	012099
29	STEEL WORM SINGLE RH	012062
30	THRUST BEARING	006052
31	STEEL WORM SINGLE RH	012026
32	THRUST BEARING	012045
33	HANDWHEEL	012061
34	SHAFT	012004
35	SAFETY VALVE	011004
36	JACKET DRAIN PETCOCK	012070
37	STAND ASSEMBLY FOR D-10	011210
38	STAND ASSEMBLY FOR D-20	011220
39	STAND ASSEMBLY FOR D-30	011230

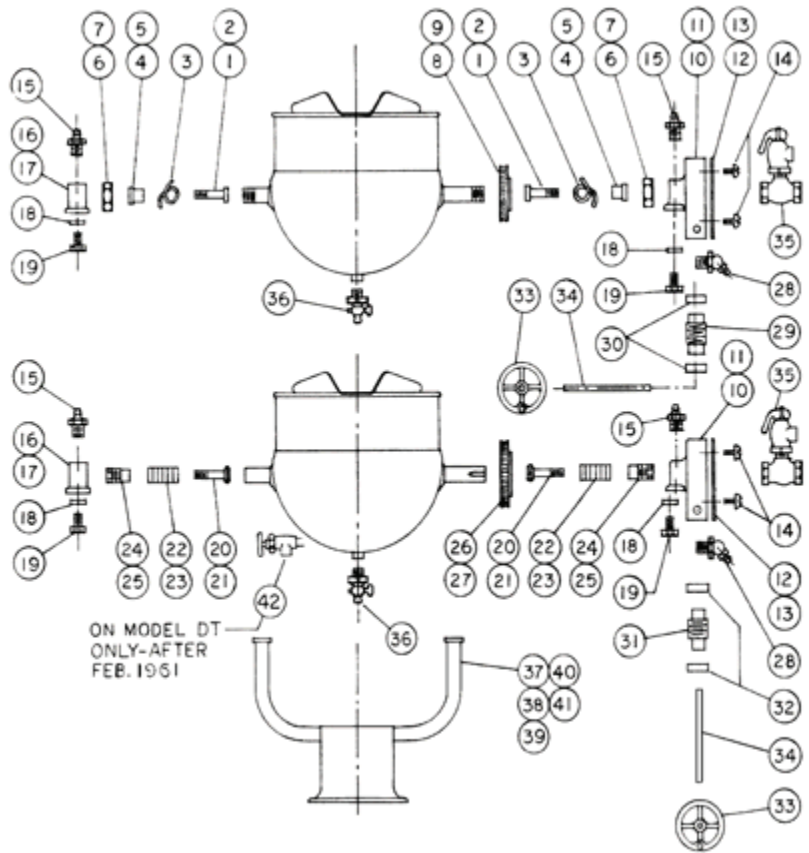

Models D, DT, DL, and DLT (before January 1974)

40	STAND ASSEMBLY FOR D-40	011240
41	STAND ASSEMBLY FOR D-60	011250
-	DRAW-OFF VALVE 1½" (COMPLETE)	009000
42	DRAW-OFF VALVE 2" (COMPLETE)	009046
-	DRAW-OFF VALVE 3" (COMPLETE)	012262
-	HANDLE FOR 1½" OR 2" TDO VALVE	009029
-	STEM FOR 1½" VALVE	009027
-	STEM FOR 2" VALVE	009048
-	STEM FOR 3" VALVE	001908
-	WING NUT FOR 1½" AND 2" VALVES	009028
-	BUCKET TRAP ½"	004183
-	BUCKET TRAP ¾"	004050
-	LOW WATER CUT-OFF 115V	010412
-	LOW WATER CUT-OFF 220V	010410
-	SNAP BUSHING	000453
-	DRAW-OFF VALVE PLUG 1½"	009737
-	DRAW-OFF VALVE PLUG 2"	009735

Parts List

Key	Description	Part No.
1	STEAM GLAND	009585
2	RING SET, PACKING (4-RING)	009588
3	WASHER, PACKING	009567
4	SPRING, TRUNNION	012403
5	RETAINER, SPRING	009587
6	RING, TRU-ARC	009586
7	BEARING, OILITE	009569
8	RACE, TRUNNION	009570
9	CASTING (NOT AVAIL. - CALL SERVICE DEPT. FOR CONVERSION KIT)	
10	"O" RING, 2.5 ID X 2.875 OD	012304
11	SCREW, HEX HEAD CAP (PRIOR TO 01/1974)	005699
12	WASHER, LOCK 3/8" (PRE-JANUARY 1974)	005702
13	BEARING, THRUST (PRE-JANUARY 1974)	012045
14	WORM, 3/4" BORE	012026
15	RUBBER GROMMET	007245
16	HANDWHEEL/SHAFT ASSEMBLY	012006
17	HANDWHEEL ASSEMBLY	012061
18	FITTING, GREASE (PRE-JANUARY 1974)	012099
19	GEAR, 92 TEETH	012022
20	SCREW, HEX SOCKET SET	012060
21	CLOSE NIPPLE (PRIOR TO JANUARY 1974)	013206
22	FULL COUPLING (PRIOR TO JANUARY 1974)	004250
23	FITTING, 90 DEGREE, GREASE	012195
24	PETCOCK, JACKET DRAIN	012070
25	SAFETY VALVE-DUPLICATE PROVIDED VALVE	-
26	VALVE, SWING CHECK 1/2 NPT	004187
27	TRAP, BUCKET WITH STRAINER 1/2"	004183
28	VALVE, ANGLE 3/8 IPS	012848
29	VALVE, ANGLE 1/2 IPS	012849
30	VALVE, ANGLE 3/4 IPS	012850
31	COUPLER, 1/2" VALVE STEM	012723
32	COUPLER, 3/8" VALVE STEM	012683
33	COUPLER, 3/4" VALVE STEM	012724
34	EXTENSION, VALVE STEM	012722
35	HEX NUT, 3/8 -11 NC	007272
36	PLAIN WASHER, 3/8"	007273
37	SLEEVE, VALVE STEM	002976
38	HANDLE, BLACK, 3 DIA	009029
39	HANDWHEEL, VALVE, WITH INSERT	001148
40	STEAM GLAND FOR 2" TRUNNION	012020
41	RING SET, PACKING	002424

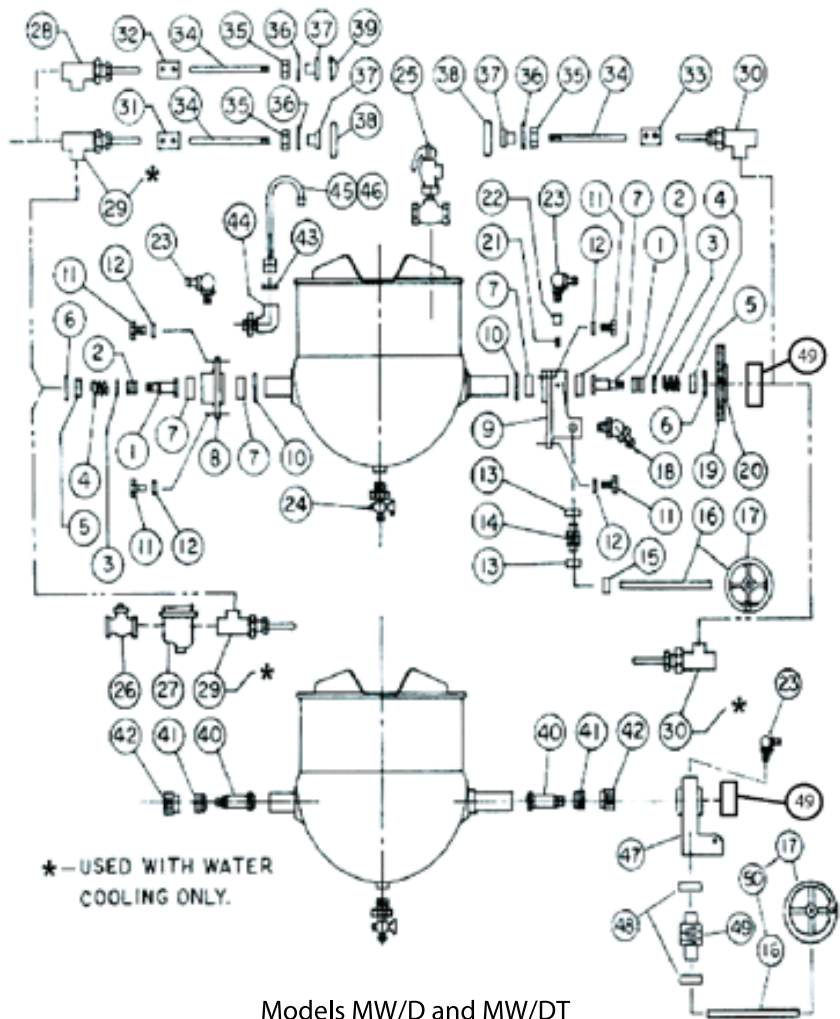

Models MW/D and MW/DT

42	NUT, PACKING FOR 2" TRUNNION	012122
43	"O" RING	010887
44	BODY/NUT, SWIVEL OUTLET	009860
45	SPOUT GOOSENECK SWIVEL 20	009861
46	SPOUT GOOSENECK SWIVEL 40-80.	009862
47	CARRIER ASSEMBLY GEAR	014079
48	BEARING, ROLLER	002790
-	DRAW-O VALVE 2" (COMPLETE)	009046
-	DRAW-O VALVE 3" (COMPLETE)	012262
-	HANDLE FOR 2" VALVE	009029
-	HANDLE FOR 3" VALVE	012209
-	STEM FOR 2" VALVE	009048
-	STEM FOR 3" VALVE	001908
-	WING NUT (WITH 001908)	-
-	Y-STRAINER, 1/2"	004181
49	COLLAR	137246

Bucket Steam Trap

Key	Description	Qty.	Part No.
1	GATE VALVE	1	004180
2	900 REDUCING STREET ELBOW	1	010666
3	CLOSE NIPPLE	3	008877
4	FEMALE UNION	1	004186
5	BUCKET STEAM TRAP*	1	004183
6	SWING CHECK VALVE	1	004187
7	GLOBE VALVE	1	004222
8	CLOSE NIPPLE	2	008238
9	FEMALE UNION	1	005516
10	900 STREET ELBOW	1	008347

* NOTE: FOR THERMOSTATIC STEAM TRAP USE
PART # 010250

Steam Inlet Size	Steam Outlet Size	Models Used On
¾" I.P.S.	¾" I.P.S.	D, DT - 20, 40, 60, DL, DLT - 20, 40, 60, 80

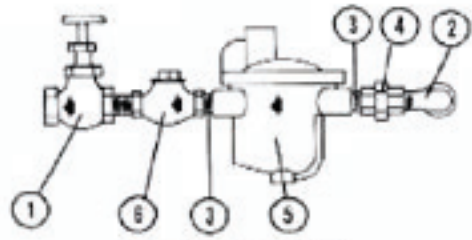

Condensate Outlet Piping

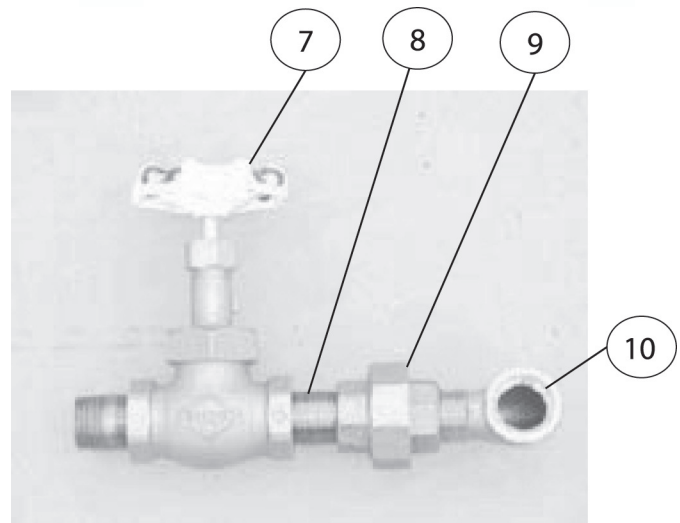

Steam Inlet Piping

Installation Diagram Chair for Discontinued Wall Mounted Kettles

GAL CAP	20	40	60	80
Liter	75	150	230	305
A	25-1/2"	31-1/2"	35-1/2"	39-1/2"
MM	647	800	901	1003
B	23-1/2"	29-1/2"	33-1/2"	37-1/4"
MM	597	749	851	946

NOTES:

1. 6" -13 LB. CHANNEL
2. SPACER SLEEVES SHOULD BE CUT TO PROPER LENGTH ON INSTALLATION TO SUIT FINISHED WALL THICKNESS
3. 7/8" DIAMETER HOLE FOR ANCHOR BOLTS ON CENTER LINE
4. FINISHED FLOOR
5. DIMENSIONS FOR KETTLES WITH 2" TDO ONLY.
6. DUE TO CONTINUED PRODUCT IMPROVEMENT, DESIGNS ARE SUBJECT TO CHANGE WITHOUT NOTICE. CHECK WITH FACTORY FOR CURRENT DESIGN.

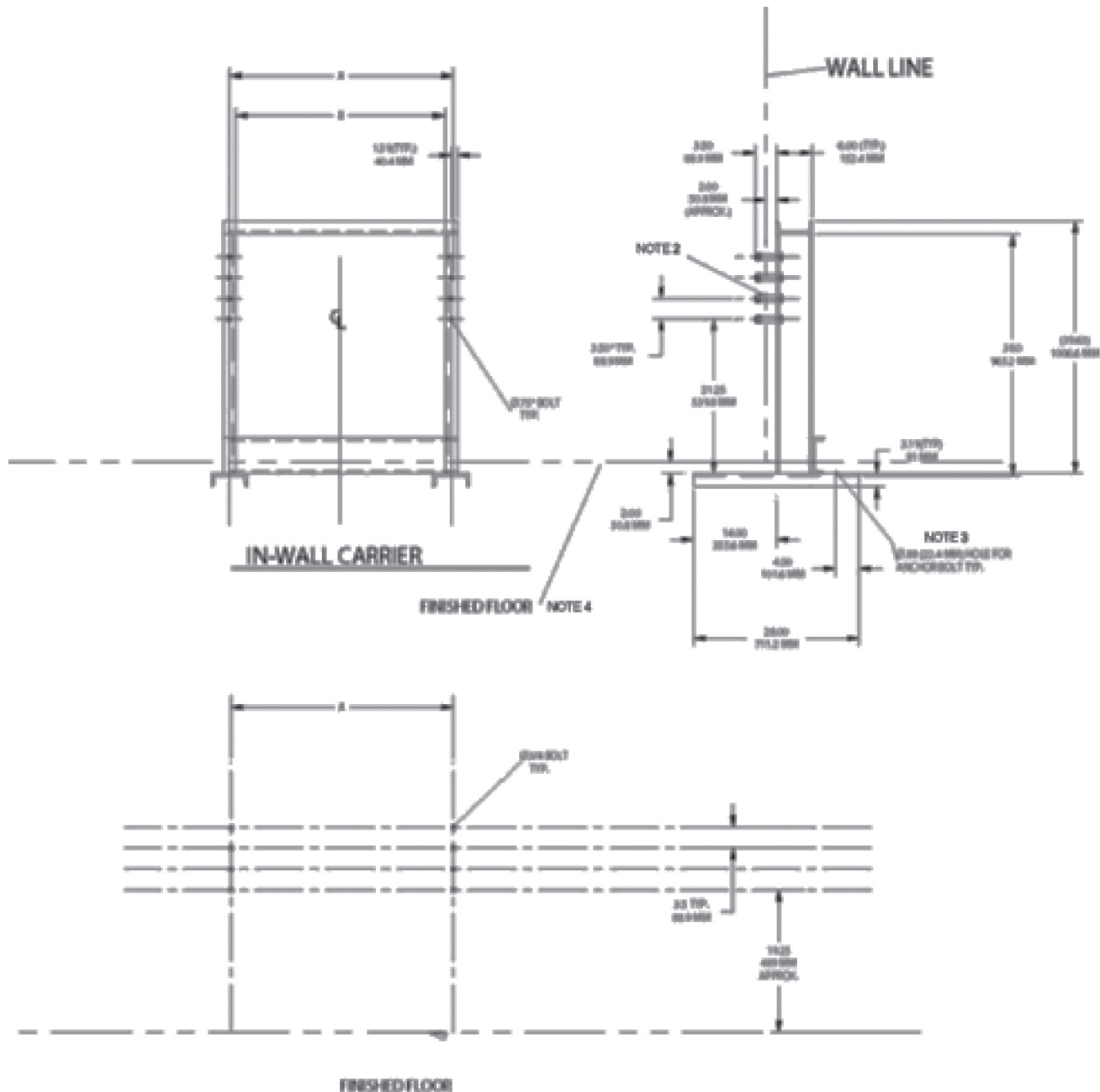



1055 Mendell Davis Drive • Jackson MS 39272
888-994-7636 • 601-372-3903 • Fax 888-864-7636
unifiedbrands.net