

IMPORTANT INFORMATION \* KEEP FOR OPERATOR \* IMPORTANT INFORMATION

## OPERATOR MANUAL

Part Number 121023

OM-HFP

DOMESTIC

**MODELS:** HFP/1,HFP/1E,  
MW/HFP/1,MW/HFP/1E  
HFP/2, HFP/2E MW/HFP/2,  
MW/HFP/2E

### Braising Pans

*Stainless Steel  
Manual Tilting Gas  
Heated*



Model HFP/1



Model HFP/2



THIS MANUAL MUST BE RETAINED FOR FUTURE REFERENCE. READ, UNDERSTAND AND FOLLOW THE INSTRUCTIONS AND WARNINGS CONTAINED IN THIS MANUAL.

#### WARNING

DO NOT STORE OR USE GASOLINE OR OTHER FLAMMABLE VAPORS AND LIQUIDS IN THE VICINITY OF THIS OR ANY OTHER APPLIANCE.

#### POST IN A PROMINENT LOCATION

INSTRUCTIONS TO BE FOLLOWED IN THE EVENT USER SMELLS GAS. THIS INFORMATION SHALL BE OBTAINED BY CONSULTING YOUR LOCAL GAS SUPPLIER. AS A MINIMUM, TURN OFF THE GAS AND CALL YOUR GAS COMPANY AND YOUR AUTHORIZED SERVICE AGENT. EVACUATE ALL PERSONNEL FROM THE AREA.

#### WARNING

IMPROPER INSTALLATION, ADJUSTMENT, ALTERATION, SERVICE OR MAINTENANCE CAN CAUSE PROPERTY DAMAGE, INJURY OR DEATH. READ THE INSTALLATION, OPERATING AND MAINTENANCE INSTRUCTIONS THOROUGHLY BEFORE INSTALLING OR SERVICING THIS EQUIPMENT.

 **GROEN**®



**IMPORTANT — READ FIRST — IMPORTANT**

- CAUTION:** SHIPPING STRAPS ARE UNDER TENSION AND CAN SNAP BACK WHEN CUT.
- CAUTION:** UNIT WEIGHS 370 TO 560 LB. (165 TO 255 KG). FOR SAFE HANDLING, INSTALLER SHOULD OBTAIN HELP AS NEEDED, OR EMPLOY APPROPRIATE MATERIALS HANDLING EQUIPMENT (SUCH AS A FORKLIFT, DOLLY, OR PALLET JACKET) TO REMOVE THE UNIT FROM THE SKID AND MOVE IT TO THE PLACE OF INSTALLATION.
- WARNING:** INSTALLATION OF THE BRAISING PAN MUST BE DONE BY PERSONNEL QUALIFIED TO WORK WITH GAS AND ELECTRICITY. IMPROPER INSTALLATION CAN RESULT IN INJURY TO PERSONNEL AND/OR DAMAGE TO EQUIPMENT.
- WARNING:** THIS UNIT IS DESIGNED FOR COMMERCIAL USE. NEVER USE HOME OR RESIDENTIAL GRADE GAS CONNECTIONS. THEY DO NOT MEET GAS CODES AND COULD BE HAZARDOUS.
- DANGER:** ELECTRICALLY GROUND THE UNIT AT THE TERMINAL PROVIDED. FAILURE TO GROUND UNIT COULD RESULT IN ELECTROCUTION AND DEATH.
- WARNING:** KEEP THE APPLIANCE AREA FREE AND CLEAR OF COMBUSTIBLE MATERIALS.
- CAUTION:** BE SURE ALL OPERATORS READ, UNDERSTAND AND FOLLOW THE OPERATING INSTRUCTIONS, CAUTIONS AND SAFETY INSTRUCTIONS CONTAINED IN THIS MANUAL.
- CAUTION:** KEEP FLOORS IN BRAISING PAN WORK AREA CLEAN AND DRY. IF SPILLS OCCUR, CLEAN IMMEDIATELY TO AVOID THE DANGER OF SLIPS OR FALLS.
- WARNING:** WHEN TILTING BRAISING PAN FOR PRODUCT TRANSFER:
- 1) USE CONTAINER DEEP ENOUGH TO CONTAIN AND MINIMIZE PRODUCT SPLASHING.
  - 2) PLACE CONTAINER ON STABLE, FLAT SURFACE, AS CLOSE TO PAN AS POSSIBLE.
  - 3) STAND TO SIDE OF PAN WHILE POURING - NOT DIRECTLY IN POUR PATH OF HOT CONTENTS.
  - 4) RETURN PAN BODY TO LEVEL POSITION AFTER CONTAINER IS FILLED OR TRANSFER IS COMPLETE.
  - 5) DO NOT OVER FILL CONTAINER. AVOID DIRECT SKIN CONTACT WITH HOT CONTAINER AND ITS CONTENTS.
- WARNING:** DO NOT HEAT AN EMPTY PAN FOR MORE THAN 5 MINUTES AT A SETTING HIGHER THAN 300°F.
- WARNING:** IF THE PAN CONTAINS ITEMS IN SAUCE OR MELTED FAT, THEY CAN SLIDE FORWARD SUDDENLY DURING TILTING AND CAUSE THE HOT LIQUID TO SPLASH OUT.
- WARNING:** AVOID ALL DIRECT CONTACT WITH HOT FOOD OR WATER IN THE PAN. DIRECT CONTACT COULD RESULT IN SEVERE BURNS.
- WARNING:** KEEP WATER AND SOLUTIONS OUT OF CONTROLS AND BURNERS. NEVER SPRAY OR HOSE THE CONTROL CONSOLE, OR ELECTRICAL CONNECTIONS.
- CAUTION:** MOST CLEANERS ARE HARMFUL TO THE SKIN, EYES, MUCOUS MEMBRANES AND CLOTHING. PRECAUTIONS SHOULD BE TAKEN TO WEAR RUBBER GLOVES, GOGGLES OR FACE SHIELD AND PROTECTIVE CLOTHING. CAREFULLY READ THE WARNINGS AND FOLLOW THE DIRECTIONS ON THE LABEL OF THE CLEANER TO BE USED.
- WARNING:** THE CONTROL BOX IS NOT WATERPROOF. TAKE CARE TO KEEP WATER AND CLEANING SOLUTIONS OUT OF THE BOX. NEVER HOSE OR SPRAY ELECTRICAL CONTROLS, CONNECTIONS OR CONTROL CONSOLE.
- WARNING:** BEFORE REPLACING ANY PARTS, DISCONNECT THE UNIT FROM THE ELECTRIC POWER SUPPLY AND CLOSE THE MAIN GAS COCK. ALLOW FIVE MINUTES FOR UNBURNED GAS TO VENT.
- CAUTION:** USE OF ANY REPLACEMENT PARTS OTHER THAN THOSE SUPPLIED BY GROEN OR AUTHORIZED DISTRIBUTORS CAN CAUSE INJURY TO THE OPERATOR AND DAMAGE TO THE EQUIPMENT AND WILL VOID ALL WARRANTIES.
- IMPORTANT:** Service performed by other than factory authorized personnel will void all warranties.

**Table of Contents**

<b>IMPORTANT OPERATOR WARNINGS (READ FIRST)</b>	<b>2</b>
<b>EQUIPMENT DESCRIPTION</b>	<b>4</b>
<b>INSPECTION AND UNPACKING</b>	<b>6</b>
<b>INSTALLATION</b>	<b>7</b>
<b>INITIAL START-UP</b>	<b>8</b>
<b>OPERATION</b>	<b>9</b>
<b>SEQUENCE OF OPERATION</b>	<b>11</b>
<b>CLEANING</b>	<b>12</b>
<b>MAINTENANCE</b>	<b>14</b>
<b>REFERENCES</b>	<b>14</b>
<b>TROUBLESHOOTING</b>	<b>15</b>
<b>PARTS LIST</b>	<b>18</b>
<b>DIAGRAMS &amp; SCHEMATICS</b>	<b>23</b>
<b>MAINTENANCE LOG</b>	<b>26</b>

# OM-HFP

## Equipment Description

Groen Gas Heated Braising Pans provide a stainless steel pan equipped with patented heat transfer fins, burner/combustion chamber, hand-operated tilting mechanism, thermostatic controls, and hinged cover. The Braising Pan serves as braising unit, griddle, fry pan, oven, kettle, bain-marie, or food warmer and server, and it can be adapted for use as a steamer.

The pan body is made from heavy-duty stainless steel welded into one solid piece, with a polished interior and exterior. A pouring lip is welded to the front wall. The cooking surface is a stainless steel clad plate fitted with welded heat transfer fins which assure uniform heat transfer over the entire surface. The gas burner/combustion chamber supplies the heat.

An easily-operated worm and gear mechanism tilts the pan and provides precise control for pouring or dumping the contents of the pan. This hand-wheel controlled mechanism is located in a stainless steel console to the right of the pan body. To assist cleaning, the pan body can be tilted past the vertical position. When the pan is tilted, the burners shut off automatically.

The thermostat provides automatic control of cooking temperature. Operating the thermostat dial on the front of the control console turns the heat on or off and sets the pan temperature.

A vented, heavy gauge, one-piece, stainless steel cover with a condensate drip shield on the rear edge is standard on the Braising Pan. A fully enclosed, spring type actuator counter-balances the cover to keep it in either the opened or closed position. The cover opens to the back and is hinged to the frame, so it moves independently of the pan body.

The basic models differ in their mounting and their ignition systems. Models HFP/1, HFP/1E, HFP/2, and HFP/2E are mounted on an open-leg frame fabricated from tubular stainless steel. MW/HFP/1, MW/HFP/1E, MW/HFP/2, and MW/HFP/2E are designed to be wall-mounted with side support arms and a splashback.

Models HFP/1, HFP/2, MW/HFP/1, and MW/HFP/2 have a standing-flame pilot light that ignites the main burner. Models HFP/1E, HFP/2E, MW/HFP/1E, and MW/HFP/2E have ignition systems that use a hot surface igniter.

Model	Pan Dimensions		Ignition
	L to R	Depth	
HFP/1-2 MW/HFP/1-2	24 5/8" (62.5cm)	7" (18cm)	Flame
HFP/1E-2 MW/HFP/1E-2	24 5/8" (62.5 cm)	7" (18cm)	Spark
HFP/1-3 MW/HFP/1-3	31 5/8" (80 cm)	7" or 9" (18 or 23cm)	Flame
HFP/1E-3 MW/HFP/1E-3	31 5/8" (80 cm)	7" or 9" (18 or 23cm)	Spark
HFP/1-4 MW/HFP/1-4	41 5/8" (1.06m)	7" or 9" (18 or 23cm)	Flame
HFP/1E-4 MW/HFP/1E-4	41 5/8" (1.06m)	7" or 9" (18 or 23cm)	Spark
HFP/2-2 MW/HFP/2-2	24 5/8" (62.5cm)	7" or 9" (18 or 23cm)	Flame
HFP/2E-2 MW/HFP/2E-2	24 5/8" (62.5 cm)	7" or 9" (18 or 23cm)	Coil
HFP/2-3 MW/HFP/2-3	31 5/8" (80 cm)	7" or 9" (18 or 23cm)	Flame
HFP/2E-3 MW/HFP/2E-3	31 5/8" (80 cm)	7" or 9" (18 or 23cm)	Coil
HFP/2-4 MW/HFP/2-4	41 5/8" (1.06m)	7" or 9" (18 or 23cm)	Flame
HFP/2E-4 MW/HFP/2E-4	41 5/8" (1.06m)	7" or 9" (18 or 23cm)	Coil

Options available with the listed models are:

1. Fill faucet with swing spout.
2. Caster mounting kit.
3. Fold-down work tray (pan support) mounted on left or right side.
4. 2" Tangent draw-off
5. Model REJ Steamer Insert set.
6. Steamer pan Carrier.
7. Quick gas disconnect with restraining cable.



**Optional Tangent Draw-Off**

Performance Data

OLD MODELS	FIRING RATE	NEW MODELS	FIRING RATE
HFP/1-2 HFP/1E-2	73,000 BTU/hr	HFP/2-2 HFP/2E-2	80,000 BTU/hr
HFP/1-3 HFP/1-E-3	90,000 BTU/hr	HFP/2-3 HFP/2E-3	104,000 BTU/hr
HFP/1-4 HFP/1E-4	120,000 BTU/hr	HFP/2-4 HFP/2E/4	144,000 BTU/hr
MW/HFP/1-2 MW/HFP/1E-2	62,000 BTU/hr	MW/HFP/2-2 MW/HFP/2E-2	80,000 BTU/hr
MW/HFP/1-3 MW/HFP/1E-3	90,000 BTU/hr	MW/HFP/2-3 MW/HFP/2E-3	104,000 BTU/hr
MW/HFP/1-4 MW/HFP/1E-4	120,000 BTU/hr	MW/HFP/2-4 MW/HFP/2E-4	144,000 BTU/hr

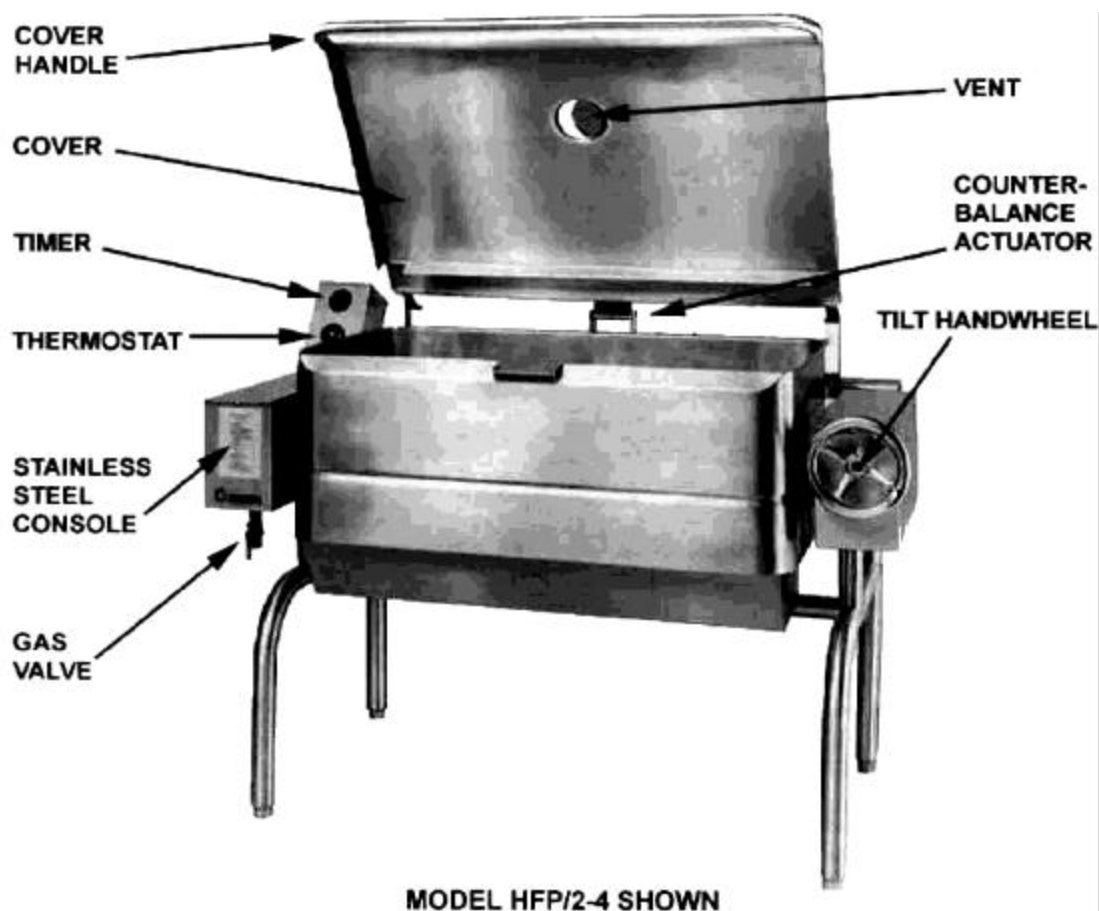

**NOTE:** MW/HFP/1 or MW/HFP/2 Braising Pan is similar to above pan, but is without legs. Wall brackets are provided. Some console dimensions are changed, but basic information and parts apply.

## OM-HFP

### Inspection and Unpacking

The unit will arrive completely assembled, wrapped in protective plastic on a heavy skid, in a heavy cardboard carton. Immediately upon receipt, inspect the carton for damage. Report any apparent shipping damage or an incorrect shipment to the delivery agent.

When installation is to begin, get someone to assist in removing the carton. Lift it straight up and away from the unit. **Do not simply raise it and push backwards - you will break the cover assembly vent handle.** Write down the model number, serial number, and installation date of your unit, and keep this information for future reference. Space for these entries is provided at the top of the Service Log in this manual.

Cut the straps holding the unit on the skid, and lift the unit straight up off the skid.

**CAUTION**  
**SHIPPING STRAPS ARE UNDER TENSION**  
**AND CAN SNAP BACK WHEN CUT.**

**UNIT WEIGHS 370 TO 560 LB (170 TO 255**  
**KG). FOR SAFE HANDLING, INSTALLER**  
**SHOULD OBTAIN HELP AS NEEDED, OR**  
**EMPLOY APPROPRIATE MATERIALS**  
**HANDLING EQUIPMENT (SUCH AS A**  
**FORKLIFT, DOLLY, OR PALLET JACKET)**  
**TO REMOVE THE UNIT FROM THE SKID**  
**AND MOVE IT TO THE PLACE OF**  
**INSTALLATION.**

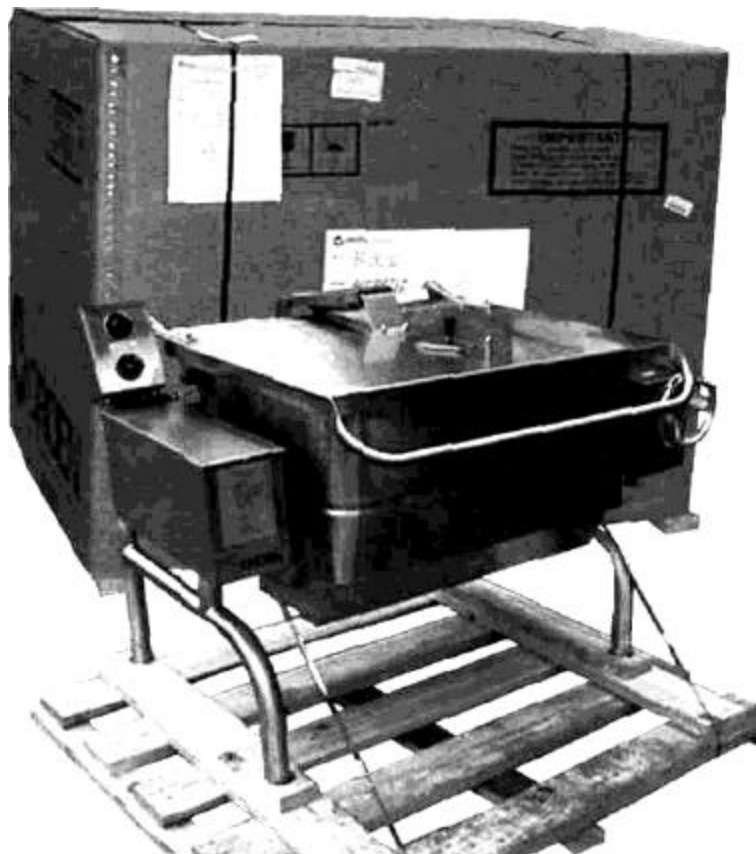

**The unit is strapped to a skid, and shipped in a heavy cardboard carton.**

## Installation

The Braising Pan should be installed in a ventilated room for efficient performance. Items which might obstruct or restrict the flow of air for combustion and ventilation must be removed. The area directly around the braising pan must be cleared of all combustible material.

**WARNING**  
**INSTALLATION OF THE BRAISING PAN MUST BE DONE BY PERSONNEL QUALIFIED TO WORK WITH GAS AND ELECTRICITY. IMPROPER INSTALLATION CAN RESULT IN INJURY TO PERSONNEL AND/OR DAMAGE TO EQUIPMENT.**

1. Installation on combustible floors is allowed, with a minimum clearance to combustible and noncombustible construction of six inches at the rear, and zero inches at the sides. will be attached, following the accompanying instructions regarding anchoring and location.
2. Install the unit under a vent hood.
3. For Open Leg Models (HFP/1, HFP/1E, HFP/2, HFP/2E):  
 Level the unit by adjusting the bullet feet or floor flanges on the legs. Be sure the tilting mechanism has been turned all the way to the horizontal position. Check levelness with a spirit level set on the bottom of the pan body. Anchor the rear legs securely to the floor if floor flanges are ordered or required.
4. Wall-Mounted Models (MW/HFP/1, MW/HFP/1E, MW/HFP/2, MW/HFP/2E)
  - a. Install the provided "chair carrier" frame in the wall to which the pan

- b. Stub in the electrical service and service and gas supply line so that they will be aligned with the control console on the left side of the pan once the pan is mounted.
- c. Mount the pan on the protruding studs of the chair carrier. **Make sure** the bottom of the pan body is level, before you proceed to the next step. To prevent sanitation problems, seal the junction between pan and the wall with an NSF-approved material such as "Silastic"

5. Complete the piping to the gas service by using  $\frac{1}{2}$  inch IPS pipe or approved equivalent.

**WARNING:**  
**THIS UNIT IS FOR COMMERCIAL USE. NEVER USE HOME OR RESIDENTIAL GRADE GAS CONNECTIONS. THEY DO NOT MEET GAS CODES AND COULD BE HAZARDOUS.**

6. For a unit on casters, complete connection to the gas supply with connectors that comply with the standard for Connectors for Moveable Gas Appliances, ANSI Z21.69a-latest edition. Restrain movement of the unit by attaching a cable or chain to the eyelet (provided at the back of the frame) and anchoring the cable or chain to the wall or floor. Make the length and location of the cable such that the unit cannot pull on the gas connection while the cable is connected.
7. The gas connection must be made with a quick disconnect device compliant with ANSI Z21.41b - latest edition.

### Typical Multi-Unit Chair Carrier

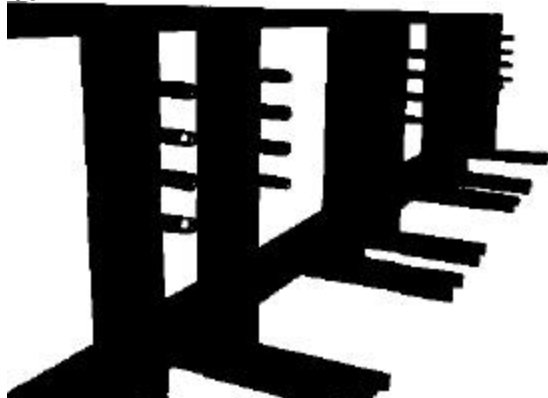

## OM-HFP

8. For models with hot surface ignition, provide 115 VAC, 60 HZ, 1 phase, 5 AMP electrical service through the rear of the electrical console. Local codes and/or The National Electrical Code should be observed in accordance with ANSI/NFPA70, latest edition. AN ELECTRICAL GROUND IS REQUIRED. The electrical schematic is located on the inside of the service panel. **In Canada**, provide electrical service in accordance with the Canadian Electrical Code, CSA-C22.1 Part 1 and/or local codes.
9. The installation must conform with local codes or with the American National Standard Z223, latest edition, National Fuel Gas Code. The pan should be installed in an adequately ventilated room with a provision for adequate air supply to the unit. The best ventilation will use a vent hood and exhaust fan. DO NOT obstruct the flue or vent duct after installation. **In Canada**, installation must conform to CAN/CGA B149 Installation Codes for Gas Appliances and Equipment and/or local codes.
10. Adequate space for proper servicing and operation is required. DO NOT block any air intake spacings to the combustion chamber or obstruct air flow.
11. After the pan has been connected to the gas supply, check all gas joints for leaks. A soap solution or other suitable leak detector should be used. **Do not use flame to check for leaks.**
12. The appliance and its individual shutoff valve must be **protected** from the gas supply piping system during any pressure testing of that system at test pressures **in excess of 1/2 PSI (3.45 kPa)**. The appliance can be **isolated** from the gas supply piping system by closing its individual manual shutoff valve during any pressure testing of the gas supply piping system.

## Initial Start-Up

Now that your Braising Pan has been installed, you should test it to ensure that the unit is operating correctly.

1. Remove literature and packing materials from the interior and exterior of the unit.
2. Put enough water into the pan to cover the bottom to a depth of  $\frac{1}{2}$  inch. With the pan body in the horizontal position, note how the water lies in the pan, to confirm that the pan was leveled properly during installation.
3. Following "To Start Pan" instructions for your pan model, begin heating the water at a thermostat setting of 235°F. At this setting, heating should continue until the water boils.

4. To shut down the unit, turn the thermostat dial to "OFF".

**WARNING**  
**WATER IS EXTREMELY HOT AND CAN CAUSE SEVERE BURNS. AVOID CONTACT WITH HOT WATER WHEN EMPTYING UNIT.**

5. Turn the tilting handwheel clockwise to pour out the water and to confirm that the pan body can be tilted smoothly from horizontal to vertical.

If the unit functions as described above, it is ready for use. If it does not, contact your local Groen Authorized Service Agency.

## Operation

### A. Controls

Operator controls for the Braising Pans are:

1. The thermostat dial, located on the control console to the left of the pan body. This dial is used to turn the thermostat on or off and to set the thermostat for pan temperatures between 175° and 425°F.
2. The main supply gas valve, installed on the gas line to the unit.
3. For HFP/1, MW/HFP/1, HFP/2, and MW/HFP/2, the manual valve is on the Combination Gas Control Valve, which is located under the pan on the gas line to the burner manifold. This valve selects settings of "OFF", "PILOT", or "ON" for the Combination Control.

4. Mechanical 0-60 minute bell timer.

### B. Operating Procedure

**WARNING**  
**KEEP THE APPLIANCE AREA FREE AND CLEAR OF COMBUSTIBLE MATERIALS.**

**CAUTION**  
**BE SURE ALL OPERATORS READ, UNDERSTAND AND FOLLOW THE OPERATING INSTRUCTIONS. CAUTIONS AND SAFETY INSTRUCTIONS CONTAINED IN THIS MANUAL.**

**KEEP FLOORS IN BRAISING PAN WORK AREA CLEAN AND DRY. IF SPILLS OCCUR, CLEAN IMMEDIATELY TO AVOID THE DANGER OF SLIPS OR FALLS.**

**HFP/1 WITH THERMOPILE IGNITION**

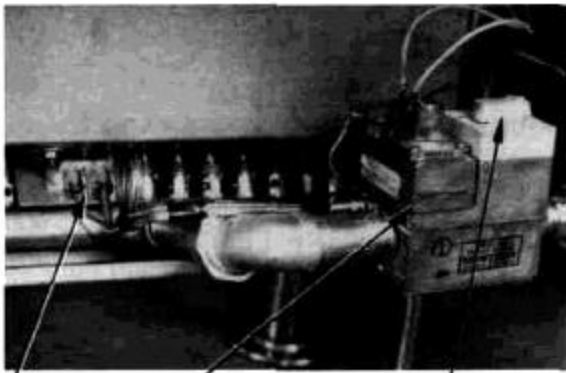

**PILOT BURNER    COMBINATION GAS CONTROL VALVE    SELECTOR KNOB**

**HFP/1 WITH ELECTRONIC SPARK IGNITION**

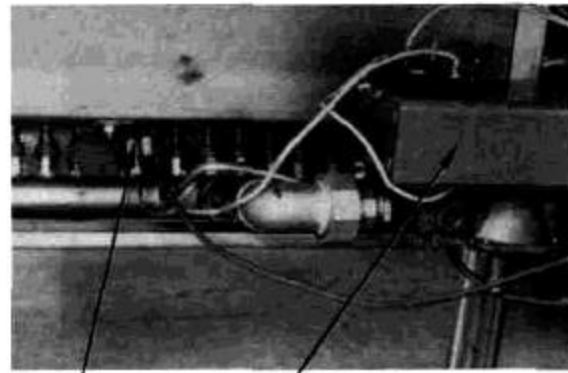

**PILOT BURNER    GAS CONTROL VALVE ASSEMBLY**

**HFP/2 WITH THERMOPILE IGNITION**

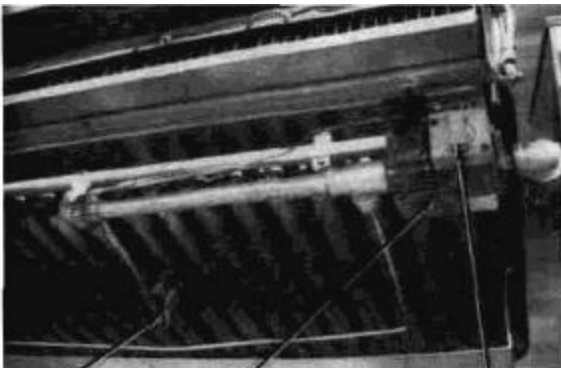

**PILOT BURNER    COMBINATION GAS CONTROL VALVE    SELECTOR KNOB**

**HFP/2 WITH GLOW COIL IGNITION**

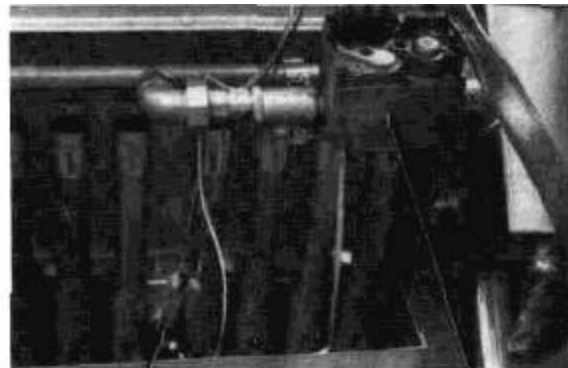

**IGNITION ASSEMBLY    GAS CONTROL VALVE**

# OM-HFP

## 1. For Models with standing-Flame Pilot

### a. To Start Pan

- (1) Set thermostat to "OFF".
- (2) Light gas pilot.
  - (a) Set knob on Combination Gas Control Valve to "OFF" by depressing the knob slightly and turning it clockwise.
  - (b) Turn the main supply gas valve ON (parallel to the gas pipe).
  - (c) Tilt the pan, so the pilot burner is easier to reach.
  - (d) Hold a lighted match at the pilot burner, while you depress the knob on the Combination Control and turn it counter-clockwise to the "PILOT" position. Continue to hold the knob down for 60 seconds.
  - (e) Release the knob. The pilot flame should stay lighted.
  - (f) Turn the knob counterclockwise to "ON".
- (3) Turn the thermostat dial to the desired temperature.

<p><b>CAUTION</b> <b>DO NOT HEAT AN EMPTY PAN FOR MORE THAN FIVE MINUTES AT A SETTING HIGHER THAN 300° F.</b></p>
---

### b. To Shut Off Pan

- (1) Set the thermostat dial to "OFF".
- (2) To turn off the gas pilot, depress the knob on the Combination Control and turn it clockwise to "OFF".

### c. To Relight Pilot

- (1) Close the main supply gas valve.
- (2) Set the thermostat to "OFF".
- (3) Depress the knob on the Combination Control and turn it clockwise to "OFF".
- (4) Wait 5 minutes, then proceed as instructed at "To Start Pan" above.

## 2. For Models with Hot Surface Ignition

### a. To Start Pan

- (1) DO NOT attempt to light the burner with a flame.
- (2) Turn on the electrical service to the unit.
- (3) Turn the main supply gas valve ON (handle parallel to the gas pipe).
- (4) Turn the thermostat dial to the desired temperature setting.

### b. To Turn Off Pan

- (1) Set the thermostat to "OFF".
- (2) For a prolonged shut-off period:
  - (a) Set the thermostat to "OFF".
  - (b) Turn the main gas valve OFF (handle at right angles to the gas pipe).
  - (c) Disconnect the electrical power from the unit.

### c. If Power Fails

- 1) Do not try to operate the unit until power is restored.
- 2) When power is restored, follow directions under "To Start Pan."

<p><b>WARNING</b> <b>WHEN TILTING BRAISING PAN FOR PRODUCT TRANSFER:</b></p>
<p>1) USE CONTAINERS DEEP ENOUGH TO CONTAIN AND MINIMIZE PRODUCT SPLASHING.</p>
<p>2) PLACE CONTAINER ON A STABLE, FLAT SURFACE, AS CLOSE TO THE BRAISING PAN AS POSSIBLE.</p>
<p>3) STAND TO THE SIDE OF THE PAN WHILE POURING – NOT DIRECTLY IN THE POUR PATH OF HOT CONTENTS.</p>
<p>4) RETURN PAN BODY TO UPRIGHT POSITION AFTER CONTAINER IS FILLED OR TRANSFER IS COMPLETE.</p>
<p>5) DO NOT OVERFILL CONTAINER. AVOID DIRECT SKIN CONTACT WITH HOT CONTAINER AND CONTENTS.</p>

## 3. To Tilt Either Model

Turn the tilting handwheel clockwise to tilt the pan body, or counterclockwise to return the pan body to horizontal.

**4. To Move a Unit on Casters**

The unit must be anchored with a cable or chain to avoid accidentally breaking or pulling loose the gas connection. When the unit is to be moved, first turn off and disconnect the gas connection.

Disconnect the cable from its anchor point on the floor or wall. Anchor the unit again as soon as it is in its new operating location or returned to the previous location. Turn on the gas supply and check for leaks with a soap solution. If leaks are found, do not operate the equipment. Call for service.

**5. To Preheat the Pan**

- a. For best braising or frying results, preheat pan before you put in any food.
- b. To get an even temperature across the pan, preheat at a setting of 300 °F or less for 15 minutes or through several on-off cycles of the burner.

**CAUTION**  
**DO NOT HEAT AN EMPTY PAN FOR MORE THAN FIVE MINUTES AT A SETTING HIGHER THAN 300°F. DAMAGE TO THE PAN COULD RESULT.**

**C. Cooking**

- 1. To simmer or slowly heat an item, set the dial at 210 °F or lower. Put the cover down to minimize moisture loss, or leave it up to help dry or reduce the product. Set the thermostat higher to cook or drive off moisture faster. You may adjust the thermostat to any setting to cook the item exactly as required.

- 2. Leave the cover vent open to let excess steam escape. For long simmering operations, you may wish to close the vent to retain moisture.



**WARNING**  
**STEAM CAN CAUSE BURNS. AVOID ESCAPING STEAM WHEN RAISING COVER.**

- 3. To check progress when the cover is closed, lift the handle of the vent cover slightly, and move it quickly to either side.
- 4. Standing to one side of the pan (to avoid the steam that will be released) grasp the nearer corner of the cover handle and raise the cover. The cover will stay in the open position until you push it down.

**WARNING**  
**ITEMS IN SAUCE OR MELTED FAT CAN SLIDE FORWARD SUDDENLY DURING TILTING AND SPLASH THE HOT LIQUID.**

- 5. To pour or dump product, remove grease, or assist cleaning, first raise the cover, then tilt the pan forward by turning the tilting handwheel. When you stop turning the wheel, the pan body will hold its position.
- 6. To set the bell timer, turn knob clockwise past five minutes, and set the desired time.

**Sequence of Operation**

The following "action-reaction" outline is provided to help the user understand how the equipment functions.

**A. Models with Standing Pilot (Thermopile System)**

When the operator presses down the knob on the Combination Gas Control Valve and turns it to "Pilot", gas is admitted to the pilot burner. Depressing the knob in this position overrides the automatic control, which otherwise shuts off all gas supply when the

thermopile is cold. Lighting and maintaining the pilot flame for sixty seconds heats the thermopile to operating temperature, so the thermopile begins to provide electric current at 750 millivolts. Electricity from the thermopile powers the control circuit and the Combination Gas Control Valve. When the thermopile begins operating at full capacity, the knob may be released.

When the knob is turned to "ON", the automatic valve for the main burner is able to open. Setting the thermostat to call for heat causes the thermostat to send a signal to the valve, which opens and admits gas to the main burner. Gas from the main burner is ignited by the pilot flame. When the pan reaches the set temperature, the thermostat switch opens, stopping the signal to the main burner valve and causing the valve to close. When the pan cools below the set temperature, the thermostat switch closes and starts another heating cycle. On-off cycling continues and maintains the pan at the desired temperature.

### **B. Models with Hot Surface Ignition**

When the operator sets the desired temperature on the thermostat dial, the thermostat switch closes and causes electric current to heat the hot surface igniter. When the coil gets hot enough to ignite gas, a sensor built into the coil signals the automatic gas control valve, which admits gas to the burner. Gas flowing from the burner is ignited by the hot surface igniter. A separate sensor detects flame at the burner and sends a signal that turns off electric power to the hot surface igniter. If flame is not sensed within 30 seconds, a timer shuts off the gas flow.

When the pan reaches the set temperature, the thermostat switch opens, stopping the signal to the gas control valve and causing the valve to close.

When the pan cools below the set temperature, the thermostat switch closes and starts another heating cycle. On-off cycling continues and maintains the pan at the desired temperature.

### **C. All Models**

The thermostat controls heating by alternately calling for flames at the full capacity of the main burner and then signaling the control to shut the burner off completely, because the control works in this "all or nothing" way, the pan will heat as fast as it can until it reaches the set temperature, no matter what that temperature is. Turning the thermostat dial to a higher setting will cause heating to continue longer, until the pan reaches the higher temperature, but it cannot make the pan heat any faster.

The pans are protected from overheating by the high-limit thermostat. If the pan temperature rises above 425°F, the high-limit thermostat causes the automatic gas control valve to close. When the pan cools, the thermostat automatically resets and permits normal operation to continue.

Turning the tilting handwheel turns a worm gear, which turns a gear wheel on one of the trunnions that support the pan body. Turning the gearwheel produces the tilting action.

**NOTE:** Neither model will heat (operate) when the braising pan has been tilted 10° or more from horizontal.

## Cleaning

### WARNING

**KEEP WATER AND SOLUTIONS OUT OF CONTROLS AND BURNERS. NEVER SPRAY OR HOSE THE CONTROL CONSOLE OR ANY ELECTRICAL CONNECTIONS.**

1. Before any cleaning operation, shut off the burner by turning the thermostat dial to "OFF". If water or cleaning solution will be sprayed, unplug the unit from the electric power source, or shut off the power at the circuit breaker or fuse panel.

2. Clean all food-contact surfaces soon after use, before the pan has cooled completely. If the unit is in continuous use, thoroughly clean and sanitize both interior and exterior at least once every 12 hours.



**CAUTION**

**MOST CLEANERS ARE HARMFUL TO THE SKIN, EYES, MUCOUS MEMBRANES AND CLOTHING. PRECAUTIONS SHOULD BE TAKEN TO WEAR RUBBER GLOVES, GOGGLES OR FACE SHIELD AND PROTECTIVE CLOTHING. CAREFULLY READ THE WARNINGS AND FOLLOW THE DIRECTIONS ON THE LABEL OF THE CLEANER TO BE USED.**

3. Scrape or rinse out large amounts of food residues, then wash the inside of the pan body with a mixture of hot water and soap or an appropriate detergent, such as Mikro-Quat from ECOLAB. Follow the detergent supplier's recommendations on strength of the solution to use. Rinse the pan thoroughly with hot water and drain completely.

4. To remove materials stuck to the equipment, use a brush, sponge, cloth, plastic or rubber scraper, or plastic wool along with the detergent or soap solution. To minimize the effort required in washing, let the detergent solution sit in the pan and soak into the residue, or heat the detergent solution briefly in the pan. Do NOT use any abrasive materials or metal implement that might scratch the surface, because scratches make the pan hard to clean and provide places for bacteria to grow. Do NOT use steel wool, which may leave particles imbedded in the pan surface and cause eventual corrosion and pitting.

5. As part of the daily cleaning program, clean all external and internal surfaces that may have been soiled. Remember to check such parts as the underside of the cover, control console, etc.

6. Controls and the control console may be cleaned with a damp cloth.

7. The exterior surface of the unit may be polished with a recognized stainless steel cleaner, such as "Zepper" from Zep Manufacturing Co.

8. If the equipment needs to be sanitized, use a sanitizing solution equivalent to one that supplies 200 parts per million available chlorine. Obtain advice on the best sanitizing agent from

your supplier of sanitizing products. Following the supplier's instructions, apply the sanitizing agent after the unit has been cleaned and drained. Rinse off the sanitizer thoroughly.

**NOTICE**

**NEVER LEAVE A CHLORINE SANITIZER IN CONTACT WITH STAINLESS STEEL SURFACES LONGER THAN 30 MINUTES. LONGER CONTACT CAN CAUSE CORROSION.**

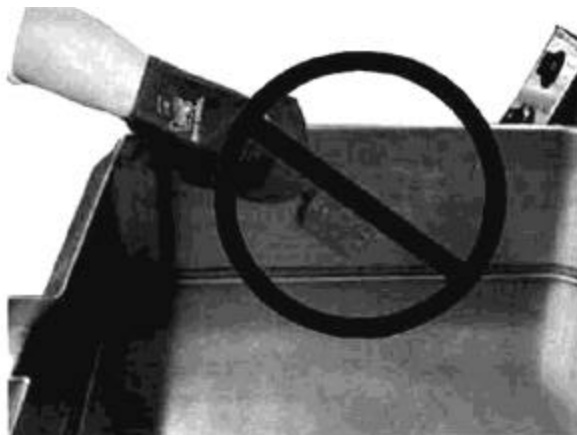

**Don't use metal implements or steel wool to clean the braising pan.**

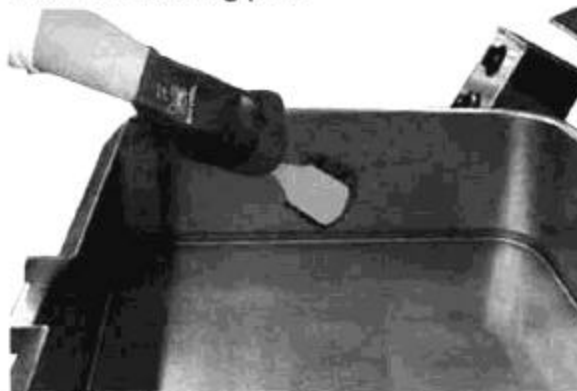

**Use a brush, cloth, sponge or other non-abrasive tool for cleaning.**

9. If there is difficulty removing mineral deposits or a film left by hard water or food residues, clean the pan thoroughly and then use a deliming agent, like Lime-Away from ECOLAB, in accordance with the manufacturer's directions. Rinse and drain the unit before further use.

10. If especially difficult cleaning problems persist, contact your cleaning product representative for assistance. The supplier has a trained technical staff with laboratory facilities to serve you.

## Maintenance

Your Braising Pan is designed to require minimum maintenance, but certain parts may need replacement after prolonged use. After installation, no user adjustment should be necessary. If a service need arises, only authorized personnel should perform the work.



**WARNING**  
**ELECTRIC POWER ALWAYS SHOULD BE SHUT OFF BEFORE WORK IS DONE ON INTERNAL COMPONENTS.**

Service personnel should check the unit at least once a year. This periodic maintenance should include inspecting electrical wires and connections, cleaning the inside of the control

console, and possible adjustment of the pilot light. At least twice a year, grease the two trunnion bearings.



**WARNING**  
**DISCONNECT ELECTRICAL POWER FROM THE UNIT BEFORE ATTEMPTING TO GREASE THE TRUNNION BEARINGS.**

A Service Log is provided with the warranty information at the back of this manual. Each time service is performed on your Groen equipment, enter the date on which the work was done, what was done, and who did it. Keep the manual with the equipment for quick and easy reference.

## References

American Gas Association Laboratories  
8501 East Pleasant Valley Rd.  
Cleveland, Ohio 44131

Z223.1-1984      *National Fuel Gas Code*

American National Standards Institute  
1403 Broadway  
New York, New York 10018

Canadian Gas Association  
55 Scarsdale Road  
Don Mills, Ontario M3B 2 R3

ECOLAB, INC.  
370 Wabasha  
St. Paul, Minnesota 55102

National Fire Protection Association  
60 Battery March Park Quincy,  
Massachusetts 02269

NFPA/54      *Installation of Gas Appliances & Gas Piping*

NFPA/70      *The National Electrical Code*  
NFPA/96      *Ventilating Hoods*

National Sanitation Foundation  
3475 Plymouth Road  
Ann Arbor, Michigan 48106

Underwriters Laboratories, Inc. 333  
Pfungsten Road Northbrook, Illinois  
60062

ZEP Manufacturing  
1390 Lunt Avenue  
Elk Grove Village, Illinois 60007

## Troubleshooting

Your Groen Braising Pan will operate smoothly and efficiently if properly maintained. However, the following is a list of checks to make in the event of a problem. If the actions suggested do not solve the problem, call your qualified Groen Service Representative. For the phone number of the nearest agency, call your area Groen representative or the Groen Parts and Service Department. If an item on the list is followed by **X**, the work should only be performed by a qualified service representative.

**WARNING**

**BEFORE REPLACING ANY PARTS, DISCONNECT THE UNIT FROM THE ELECTRICAL POWER SUPPLY AND CLOSE THE MAIN GAS VALVE. ALLOW FIVE MINUTES FOR GAS TO VENT. USE OF ANY REPLACEMENT PARTS OTHER THAN THOSE SUPPLIED BY GROEN OR THEIR AUTHORIZED DISTRIBUTORS CAN CAUSE INJURY TO THE OPERATOR AND DAMAGE TO THE EQUIPMENT AND WILL VOID ALL WARRANTIES.**

**Important: Service performed by other than factory authorized personnel will void all warranties.**

SYMPTOM	WHO	WHAT TO CHECK
<b>X</b> indicates items which must be performed by an authorized technician.		
<b>A. All Models</b>		
Pan is hard to tilt.	Auth Service Rep Only	Gears for foreign materials, lubrication, and alignment. <b>X</b>
Burners will not light	User	a. That the main gas supply valve is open (handle is in line with the gas pipe) b. Gas supply to the building. c. That the pan body is horizontal.
	Auth Service Rep Only	d. Thermostat operation. The thermostat should click when the dial is rotated to settings above and below the temperature of the pan. <b>X</b>
Pan continues to heat after it reaches desired temperature	User	a. Thermostat dial setting
	Auth Service Rep Only	b. Thermostat calibration. <b>X</b> c. Thermostat operation. The thermostat should click when the dial is rotated to settings above and below the temperature of the pan. <b>X</b>
Pan stops heating before reaching desired temperature.	User	a. Thermostat dial setting.
	Auth Service Rep Only	b. Thermostat calibration. <b>X</b> c. Thermostat operation. The thermostat should click when the dial is rotated to settings above and below the temperature of the pan. <b>X</b>
Pan heats unevenly	User	a. That the pan body is horizontal. b. That the pan is preheated properly in accordance with the instructions in the operation section of this manual.

# OM-HFP

**Important: Service performed by other than factory authorized personnel will void all warranties.**

SYMPTOM	WHO	WHAT TO CHECK
		X indicates items which must be performed by an authorized technician.

## **B. Models with Thermopile Ignition System**

Pilot will not light.	User	a. Lighting procedure, to ensure that the instructions in the Operation section of this manual are followed
	Auth Service Rep Only	b. That the pilot gas supply line is purged of air. <b>X</b> c. Pilot gas adjustment screw, to ensure that it is open. <b>X</b> d. Pilot tubing and orifice for clogging. <b>X</b>
Pilot flame goes out when Combination Control knob is released.	Auth Service Rep Only	a. Pilot gas adjustment. <b>X</b> b. Are connections from Powerpile generator to Pilotstat power unit and Powerpile operator clean and secure? <b>X</b> c. Are open and closed circuit output voltages of the generator in the acceptable range shown by the charts in the manual for the W720 Systems Tester? <b>X</b> d. Resistance of the Pilotstat power unit. <b>X</b> e. If an appropriate meter is not available, replace first the generator, than the power unit. <b>X</b>
Pan will not heat, and pilot light is out	User	a. Is the Combination Gas Control Valve knob turned ON? b. Check the pilot tubing and orifice for clogging.
	Auth Service Rep Only	c. Are connections from Powerpile generator to Pilotstat power unit and Powerpile operator clean and secure? <b>X</b> d. Are Open and closed circuit output voltages of the generator in the acceptable range shown by the charts in the manual for the W720 Systems Tester? <b>X</b> e. If an appropriate meter is not available, replace the generator. <b>X</b>
Pan will not heat, but pilot light is burning.	Auth Service Rep Only	a. That high-limit thermostat switch is closed. <b>X</b>

**Important: Service performed by other than factory authorized personnel will void all warranties.**

SYMPTOM	WHO	WHAT TO CHECK X indicates items which must be performed by an authorized technician.
---------	-----	---

**C. Models with Coil Ignition System (Refer to Schematic)**

Burner does not come on, and glow coil does not heat.	User	a. That electric power is being supplied to the unit.
	Auth Service Rep Only	b. For 115V input to the control module. <b>X</b> c. For a 24V supply at the transformer. <b>X</b> d. For 24V between pins "2" and "4" of the control module. If not present, check the thermostat/high-limit circuit for open thermostat switches. <b>X</b> e. Voltage supply to the igniter. Remove the igniter plug from the control module receptacle and read voltage across the igniter receptacle pins. If 115V is present, replace the igniter. If 115V is not present, replace the control module. <b>X</b> f. Voltage across the terminals of the main gas valve solenoid. If 24 VAC is present, replace the gas valve assembly. If not, replace the control module. <b>X</b>
Burner does not come on, but the igniter heats.	Auth Service Rep Only	a. Voltage across the terminals of the gas valve solenoids. If 24 VAC is present, replace the gas valve assembly. If not, replace the control module. <b>X</b> b. Ground connection of module terminal "12" (green wire) for firm attachment. <b>X</b> c. Flame sensing probe and wire "11" (blue) for a short to ground. If found, correct the short or replace the probe. <b>X</b> d. For a short to ground at 24V source. If the transformer is shorted, correct the short and replace the control module. <b>X</b> e. After the transformer has been replaced, check the flame sensing function. If flame sensing is not working, reverse the 115V or 24V leads on the control transformer side. <b>X</b>

**OM-HFP**

**Parts List - HFP/1 & HFP/1E Models**

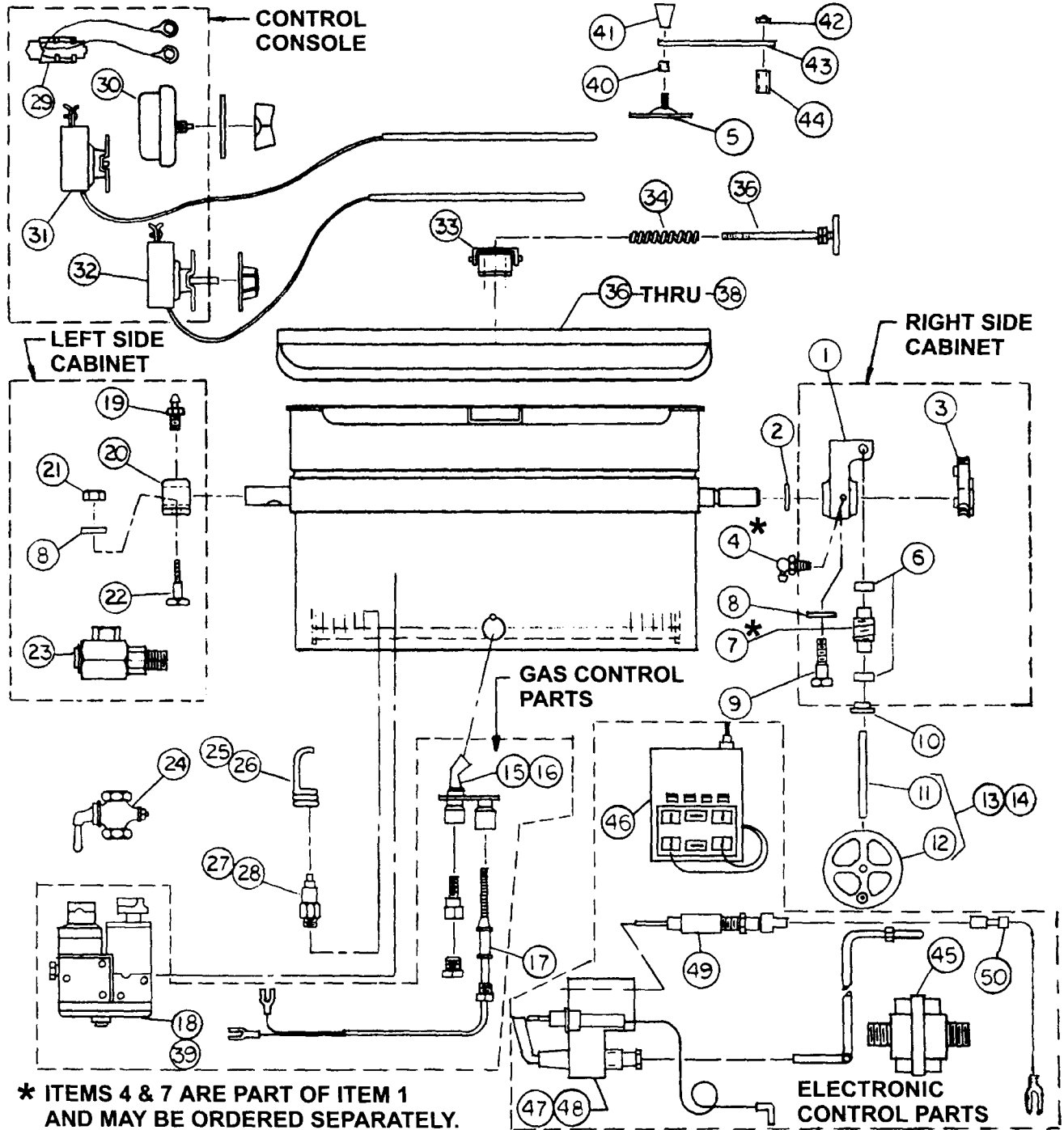

**Parts List - HFP/1 & HFP/1 Models**

To order parts, contact your authorized Groen Service Agency. Supply the model designation, part description, part number, quantity, and, where applicable, voltage and phase.

Key	Description	Part No.	Key	Description	Part No.
1	Casting Gear Carrier	014079	27	Burner Tip, Natural Gas	001133
2	Retaining Ring	012826	28	Burner Tip, Propane	017765
3	Gear Sector, Worm	009829	29	Mercury Switch 7 Clip	007517
4	Grease Fitting, 90 Degree	012195	30	Timer, 0-60 Minute	001154
5	Cover, Vent, with Weld Stud	003265	31	Thermostat, High Limit, 425 Deg.	013481
6	Thrust Bearing	002790	32	Thermostat, Operating	041700
7	Worm, 3/4 inch Bore	012026	33	Actuator, Complete	014085
8	Lockwasher, 3/8 inch	005618	34	Spring, Actuator	012533
9	Screw, Hex Head 3/8-16 N.C. x 5/8"	005449	35	Rod Assembly Spring	012524
10	Bushing	000453	36	Cover Assembly, HFP/1-2	014030
11	Shaft, 3/4 x 15	003123	37	Cover, Size 3	048819
12	Handwheel and Handle Assembly	012061	38	Cover, Size 4	048818
13	Handwheel and Shaft	003130	39	Valve, Gas Control, Natural Gas	002648
14	Handwheel and Shaft Assy. Mil only	012006	40	Spacer, Short Front	002378
15	Pilot Burner, Natural Gas	001125	41	Knob, Plastic	002408
16	Pilot Burner, Propane	001129	42	Nut, Dome	005471
17	Thermopile	001126	43	Arm, Vent Cover	002377
18	Valve, Gas Control, Propane	002649	44	Spacer, Long Rear	002378
19	Grease Fitting, Straight	012100	45	Transformer, Step-down 120/24V	074839
20	Bearing, Two inch Trunnion	013488	46	Gas Valve	079801
21	Nut, Hex Head 3/8-16 NC x 1 1/2	005619		Ignition Control Unit (for LP gas add 079802)	079803
22	Screw, Hex Head 3/8-16 NC x 1 1/2	005615			
23	Swivel Joint	076680	47	Burner Proven Pilot, Natural Gas	003325
24	Gas Valve, 3/4 IPS	008172	48	Burner Proven Pilot, Propane Gas	003326
25	Flame Spreader, Natural Gas	013489	49	Sensing Probe, Pilot Flame	003328
26	Flame Spreader, Propane	014391	50	Lead, Probe, 30 Inch	003329

Parts List - HFP/2 & HFP/2E Models

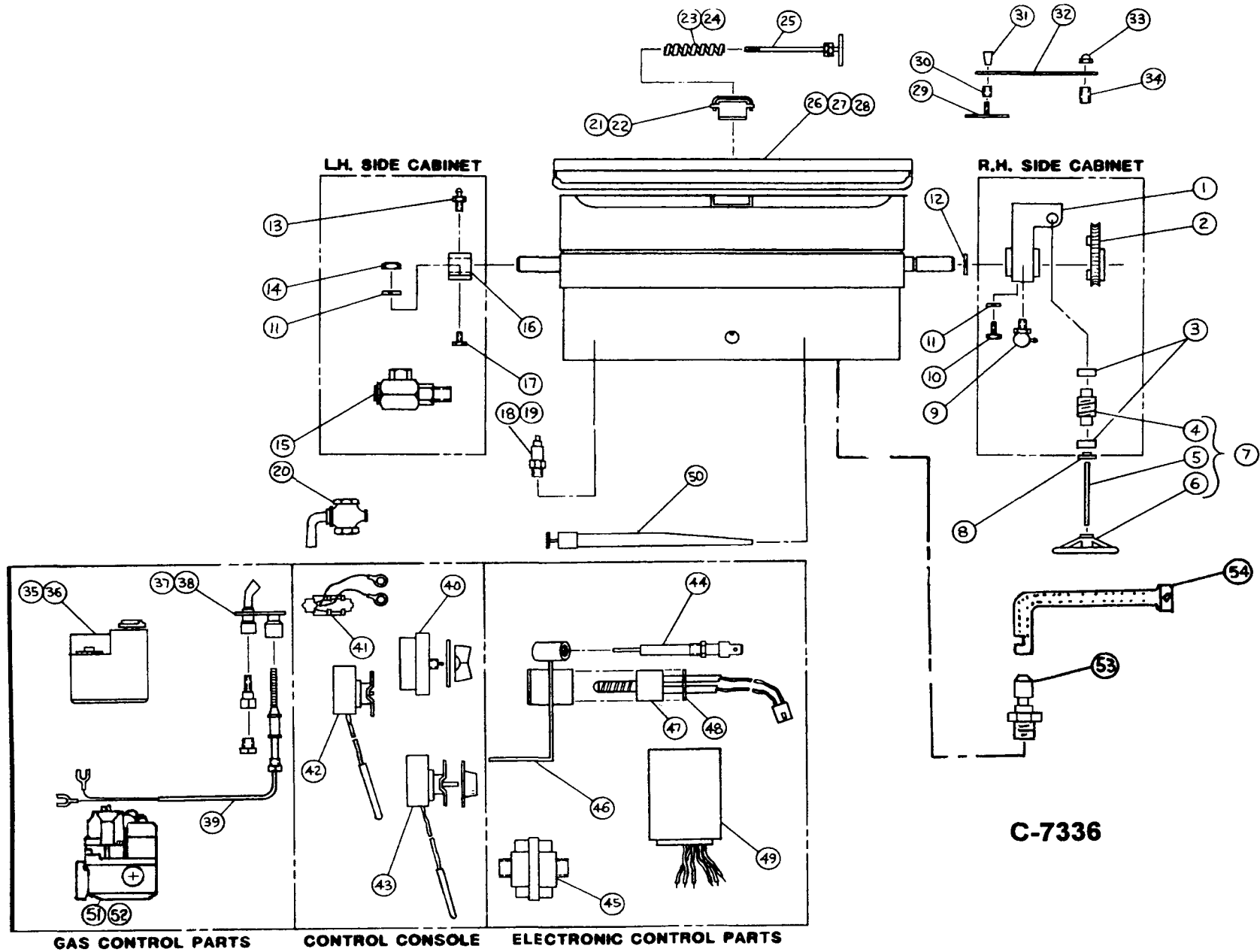

**Parts List - HFP/2 & HFP/2E Models**

To order parts, contact your authorized Groen Service Agency. Supply the model designation, part description, part number, quantity, and, where applicable, voltage and phase.

Key	Description	Part No.	Key	Description	Part No.
1	Gear Carrier Assembly (Casting)	014079	31	Knob - Plastic	002408
2	Worm Gear Sector	009829	32	Arm - Vent Cover	002377
3	Thrust Bearing	002790	33	Nut - Acorn	005471
4	Worm Gear (Single R.H.)	012026	34	Spacer - Long	012733
5	Handwheel Shaft (15 3/8" long)	003123	35	Gas Control Valve - Nat. Stnd. Plt.	002648
6	Handwheel Assembly	012061	36	Gas Control Valve - Prop. Stnd. Plt	002649
7	Handwheel Shaft & Worm Assy.	049868	37	Pilot - Burner (Natural)	001125
8	Bushing - Snap	000453	38	Pilot - Burner (Propane)	001129
9	90° Alemite Grease Fitting	012195	39	Thermopile	001126
10	Hex Head Screw 3/8" -16 x1" long	005612	40	Timer - Minute Cycle (0-60)	001154
11	Washer - Lock 3/8"	005618	41	Tilt Switch & Clip	007517
12	Retaining Ring - external (2")	012826	42	Thermostat (425°F)	013481
13	Alemite Grease Fitting (straight)	012100	43	Thermostat (100°F to 450°F)	041700
14	Nut - Hex 3/8-16	003566	44	Sensing Probe	003328
15	Swivel Joint	076680	45	Transformer 120/24V (before 5/91)	074839
16	Trunnion Race (Casting)	013488		Transformer 120/24V (after 6/91)	074839
17	Hex Head Screw 3/8" -16 x 1 1/2" lg.	005615	46	Bracket - Carborundum	066013
18	Orifice #54 (Natural Gas)	045897	47	Igniter	054285
19	Orifice #65 (Propane Gas)	050047	48	Retaining Clip	012947
20	Gas Valve (Brass)	008127	49	Ignition Sys Ctrl (coil) before 5/91	088252
21	Actuator Bracket Assy (size 2) 7"	074627		Ignition Sys Ctrl (coil) after 4/1991	088252
	Actuator Bracket Assy (size 2) 9"	074630	50	Burner Tube	051619
22	Actuator Bracket Assy (size 3-4) 7"	014085	51	Gas Valve Natural (coil)	049555
	Actuator Bracket Assy (size 3-4) 9"	014085	52	Gas Valve Propane (Coil)	049557
23	Spring (size 2)	012413	53	Orifice Ignition Tube	See Table
24	Spring (size 3 & 4)	012533	54	Ignition Tube Size 2	073190
25	Spring Rod Assembly	012524		Ignition Tube Size 3	055008
26	Cover Assembly (size 2)	014030		Ignition Tube Size 4	046406
27	Cover Assembly (size 3)	048798		24 V Igniter	088252
28	Cover Assembly (size 4)	046450		115 V RAM H1 Control	088253
29	Vent Cover with Stud	003265		24 V RAM H-4 Control	088254
30	Spacer - Short	002378			

## Parts List - Fuel Gas Conversion

(For conversion of a natural gas unit to propane or a propane model to natural gas)

### Model: HFP/1 and HFP/1E

#### HFP/1 WITH STANDING PILOT

#### HFP/1 E WITH SPARK IGNITION

DESCRIPTION	QTY	NAT GAS	LP GAS	DESCRIPTION	QTY	NAT GAS	LP GAS
Orifice/Pilot	1	001125	001129	Pilot Burner	1	003750	003751
Orifice/Burner	*	001133	017765	Orifice/Burner	*	001133	017765
Flame Spreader	*	013489	014391	Flame Spreader	*	013489	014391
Gas Valve	1	002648	002649	Gas Valve	1	079801	
				Spring Valve	1		079802
New Serial Plate	1	065658	065658	New Serial Plate	1	065658	065658

**NOTE:** Above parts for spark are for units with separate ignition box. If unit is older, it will have the valve and ignition boxes together. If this is the case, replace both the valve (079801) and ignition box (079803). Then add the spring (079802).

### Model: HFP/2 and HFP/2E

#### HFP/2 WITH STANDING PILOT

#### HFP/2E WITH HOT SURFACE IGNITION

DESCRIPTION	QTY	NAT GAS	LP GAS	DESCRIPTION	QTY	NAT GAS	LP GAS
Pilot Burner	1	001125	001129	Glow Coil	1	054285	054285
Orifice/Burner	*	045897	050047	Orifice/Burner	*	045897	050047
Gas Valve	1	002648	002649	Gas Valve	1	049555	049557
Serial Plate	1	065658	065658	Serial Plate	1	065658	065658

#### \*Burner Orifice "Quantity" Chart

Model	Size 2	Size 3	Size 4
HFP/1	18	28	38
HFP/2	13	15	18

# Diagrams and Schematics Thermopile Ignition System — HFP/2 Models

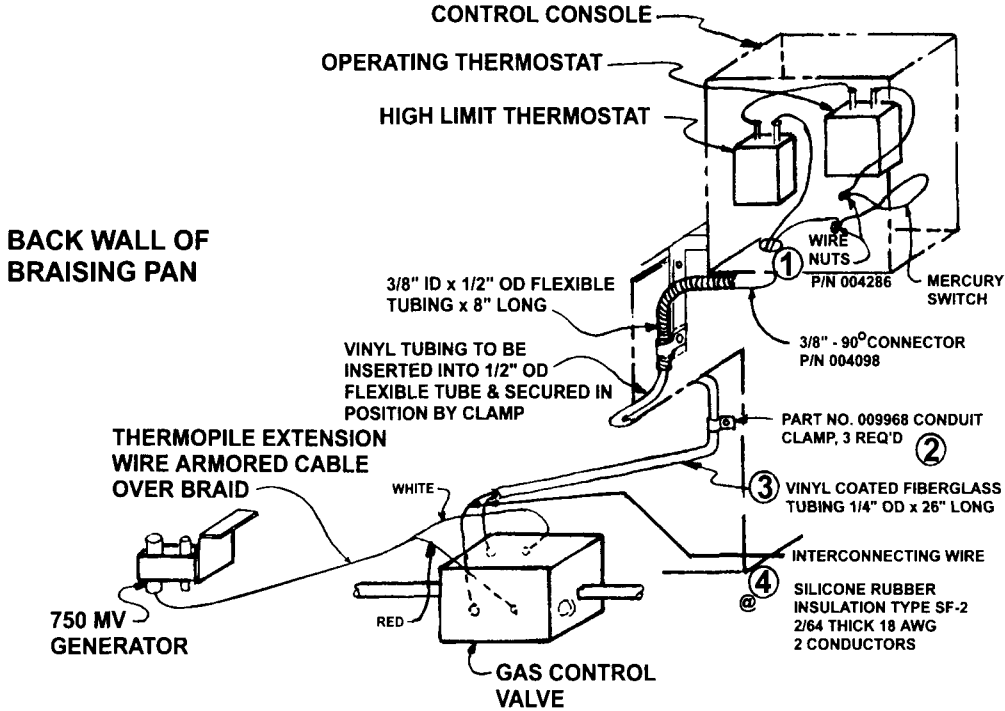

## Wiring Diagram - HFP/1 Models

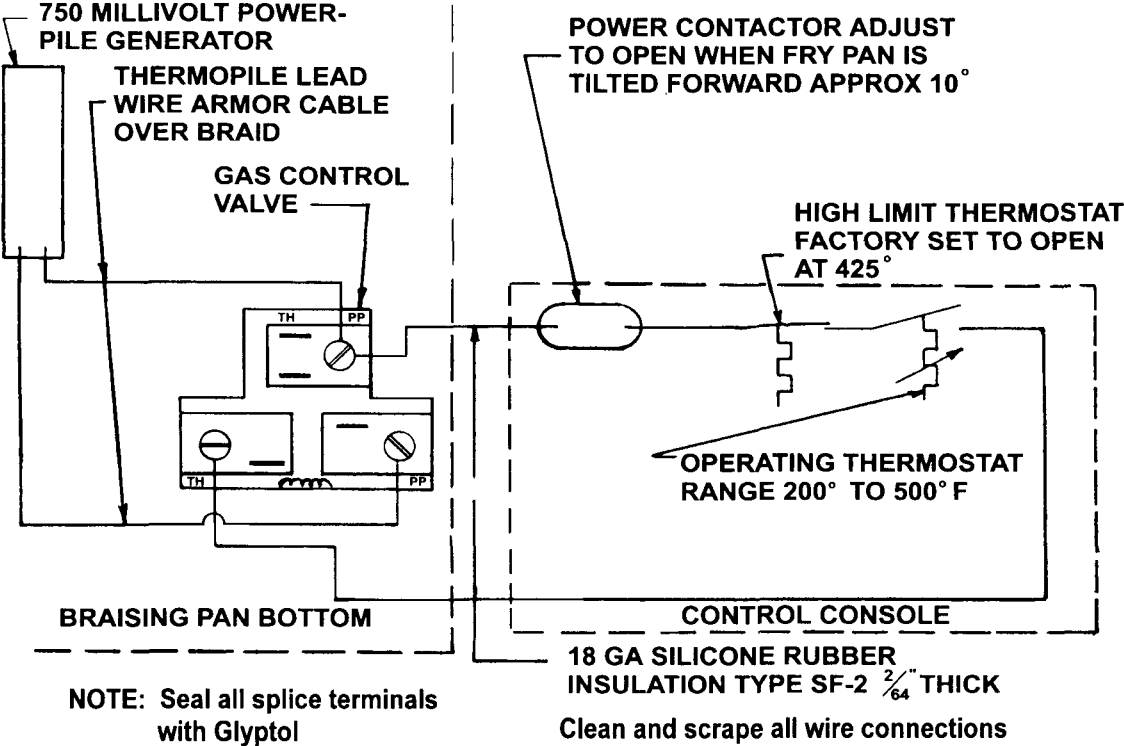

# OM-HFP

## Electronic Coil Ignition System HFP/2E Models (Before May 1991)

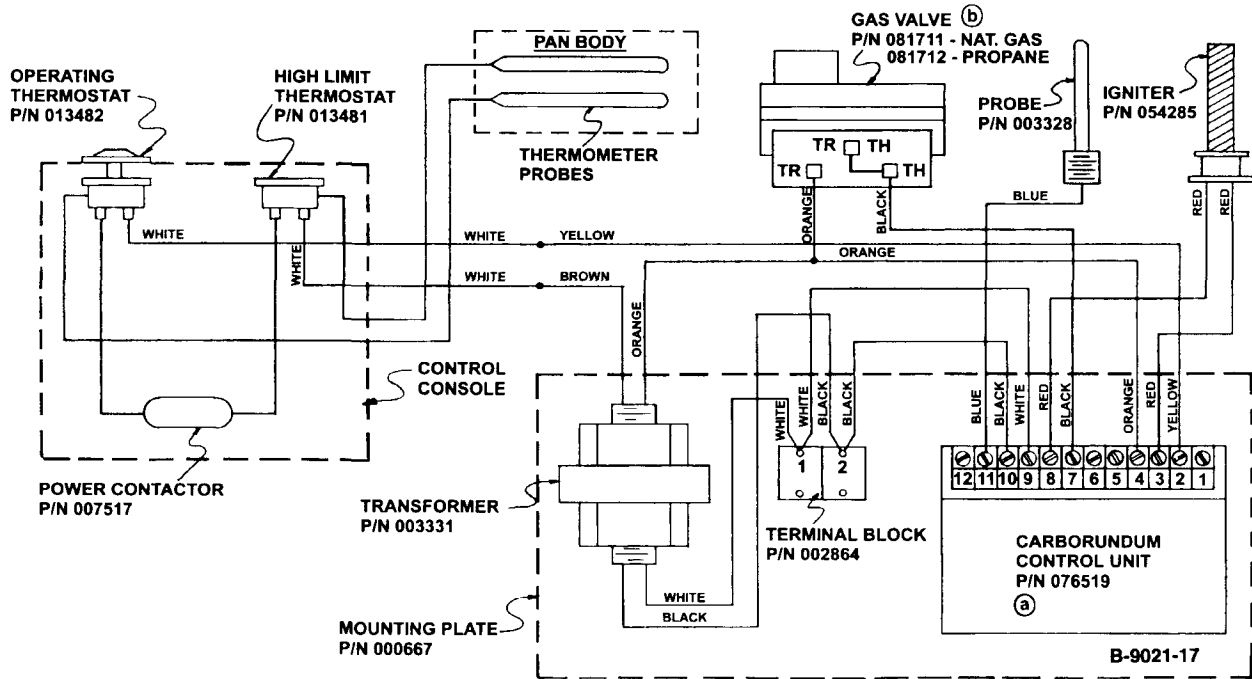

## Electronic Coil Ignition System HFP/2E Models (After April 1991)

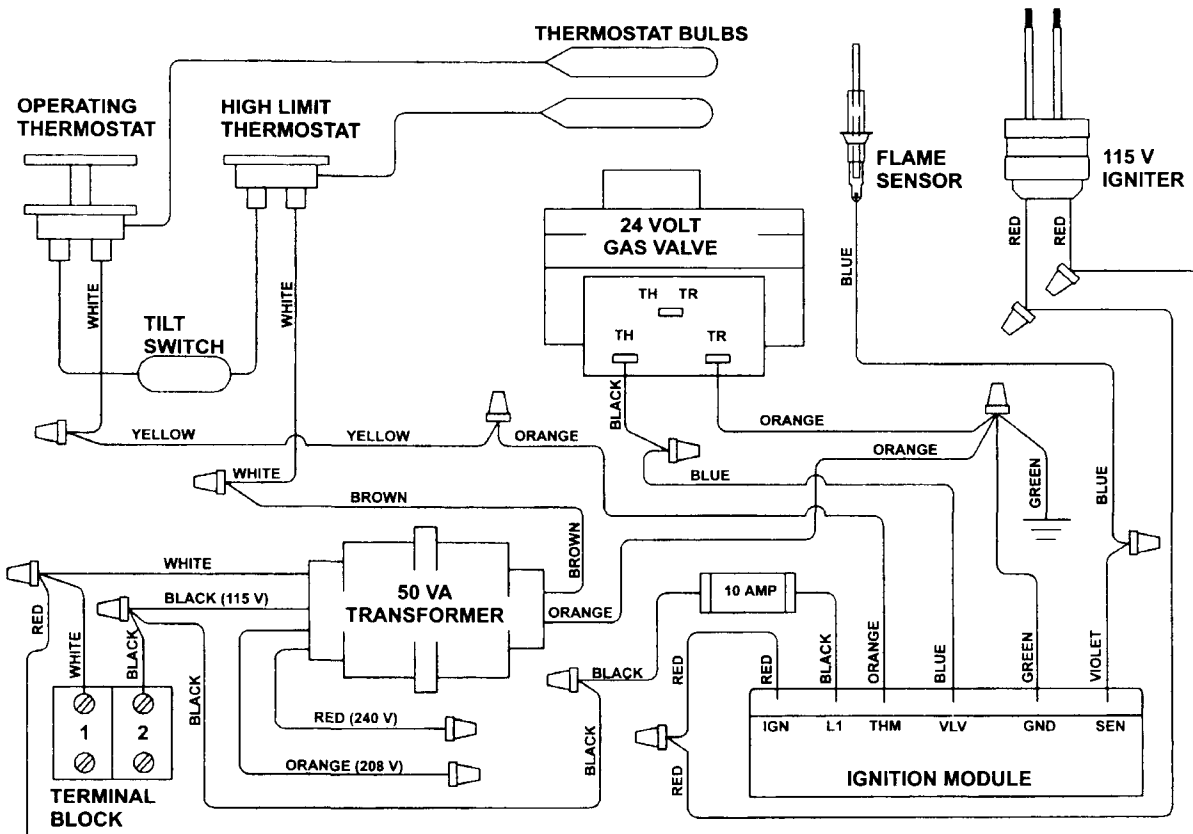





**To Commercial Purchasers \*****(Domestic U.S., Hawaii &  
Canadian Sales Only)**

Groen Foodservice Equipment ("Groen Equipment") has been skillfully manufactured, carefully inspected and packaged to meet rigid standards of excellence. Groen warrants its Equipment to be free from defects in material and workmanship for (12) twelve months with the following conditions and subject to the following limitations.

- I. This parts and labor warranty is limited to Groen Equipment sold to the original commercial purchaser/users (but not original equipment manufacturers), at its original place of installation in the continental United States, Hawaii and Canada.
- II. Damage during shipment is to be reported to the carrier, is not covered under this warranty, and is the sole responsibility of purchaser/user.
- III. Groen, or an authorized service representative, will repair or replace, at Groen's sole election, any Groen Equipment, including but not limited to, draw-off valves, safety valves, gas and electric components, found to be defective during the warranty period. As to warranty service in the territory described above, Groen will absorb labor and portal to portal transportation costs (time & mileage) for the first twelve (12) months from date of installation or fifteen (15) months from date of shipment from Groen.
- IV. This warranty does not cover boiler maintenance, calibration, periodic adjustments as specified in operating instructions or manuals, and consumable parts such as scraper blades, gaskets, packing, etc., or labor costs incurred for removal of adjacent equipment or objects to gain access to Groen Equipment. This warranty does not cover defects caused by improper installation, abuse, careless operation, or improper maintenance of equipment. This warranty does not cover damage caused by poor water quality or improper boiler maintenance.
- V. **THIS WARRANTY IS EXCLUSIVE AND IS IN LIEU OF ALL OTHER WARRANTIES, EXPRESSED OR IMPLIED, INCLUDING ANY IMPLIED WARRANTY OF MERCHANTABILITY OR FITNESS FOR A PARTICULAR PURPOSE, EACH OF WHICH IS HEREBY EXPRESSLY DISCLAIMED. THE REMEDIES DESCRIBED ABOVE ARE EXCLUSIVE AND IN NO EVENT SHALL GROEN BE LIABLE FOR SPECIAL, CONSEQUENTIAL OR INCIDENTAL DAMAGES FOR THE BREACH OR DELAY IN PERFORMANCE OF THIS WARRANTY.**
- VI. Groen Equipment is for commercial use only. If sold as a component of another (O.E.M.) manufacturer's equipment, or if used as a consumer product, such Equipment is sold AS IS and without any warranty.

**\* (Covers All Foodservice Equipment Ordered After October 1,1995)**