



# OPERATOR MANUAL

IMPORTANT INFORMATION, KEEP FOR OPERATOR

888-994-7636, fax 888-864-7636  
unifiedbrands.net

THIS MANUAL MUST BE RETAINED FOR FUTURE REFERENCE. READ, UNDERSTAND AND FOLLOW THE INSTRUCTIONS AND WARNINGS CONTAINED IN THIS MANUAL.

**WARNING** Improper installation, adjustment, alteration, service or maintenance can cause property damage, injury or death. Read the installation, operating and maintenance instructions thoroughly before installing or servicing this equipment.

**NOTIFY CARRIER OF DAMAGE AT ONCE** It is the responsibility of the consignee to inspect the container upon receipt of same and to determine the possibility of any damage, including concealed damage. Groen suggests that if you are suspicious of damage to make a notation on the delivery receipt. It will be the responsibility of the consignee to file a claim with the carrier. We recommend that you do so at once.

**Manufacture Service/Questions 888-994-7636.**

This manual provides information for:

## STEAM JACKETED KETTLE MODELS TDB(C)-20/24/40/48 (C,A) (CE) INTERNATIONAL

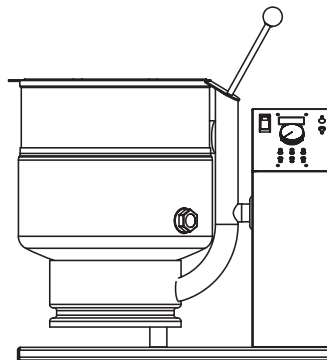

KLENZADE SALES CENTER ECOLAB, Inc.  
370 Wabasha  
St. Paul, Minnesota 55102

### REFERENCES

NSF INTERNATIONAL  
798 N. Dixboro Rd.  
P.O. Box 130140  
Ann Arbor, Michigan 48113-0140

NATIONAL FIRE PROTECTION ASSOCIATION  
60 Battery March Park  
Quincy, Massachusetts 02269

NFPA/70 - The National Electric Code

UNDERWRITERS LABORATORIES, INC.  
333 Pfingsten Road  
Northbrook, Illinois 60062

ZEP MANUFACTURING COMPANY  
1310-T Seaboard Industrial Boulevard  
Atlanta, Georgia 30318

### EQUIPMENT DESCRIPTION



The TDB and TDBC units are table top, tilting, steam jacketed kettle with an electronically controlled, self-contained, electrically-heated steam supply and appropriate controls, mounted on a sturdy base. The kettle is available in 20, 24, 40 or 48 quart (18.8, 22.6, 37.6 or 45.3 liters) capacities.

The body of the kettle is constructed of stainless steel, welded into one solid piece. The kettle is furnished with a reinforced rim and a butterfly shaped pouring lip. It has a steam jacket rated for working pressures up to 50 psi (345 kPa, 3.45 bar). Kettle finish is 180 emery grit on the inside and bright semi-deluxe on the outside. A tilt handle on the TDB and a hand wheel crank on the TDBC kettle allows the operator to manually tilt the kettle body in a controlled manner. Pour height accepts pans up to 4 " (10 cm) high on a table top.

A built-in steam generator, sized for the kettle capacity and heated by electricity, delivers steam into the jacket. "Airless" operation of the steam jacket permits uniform, efficient heating at temperatures as low as 150°F (65.5°C) and as high as 295°F (146°C). In addition to the electronic temperature control, the unit has a tilt cut-off switch, low water cut-off, safety valve, and high-limit pressure switch as safety features. A heating indicator light, pressure gauge, and sight glass are provided for monitoring kettle operation.

A single electrical connection is required for installation. The unit may be ordered for use with 230 VAC, 1 Phase, 50 Hz, or 400 VAC, 3 Phase, 50 Hz power.

Options available include:

1. Kit, cover and holder (P/N 128609, 20/24 qt - P/N 139806, 40/48 qt).
2. One-piece, lift-off cover (P/N 128003, 20/24 qt - P/N 128002, 40/48 qt).
3. Holder for Lift-off cover (P/N 133837).
4. Basket insert (P/N 001159, 20/24 qt - P/N 001161, 40/48 qt).
5. Lip Strainer (P/N 005187, 20/24 qt - P/N 005186, 40/48 qt).
6. Stand that supports the unit and holds a pan in position for filling (Model TS/9).



Information contained in this document is known to be current and accurate at the time of printing/creation. Reference our product line website for the most updated product information and specifications. © 2023 Electrolux Professional, Inc. All Rights Reserved.

## IMPORTANT - READ FIRST - IMPORTANT

**IMPORTANT:** THIS APPLIANCE IS MARKED “CE” ON THE BASIS OF COMPLIANCE WITH EMC AND LOW VOLTAGE DIRECTIVE.

**WARNING:** BEFORE REPLACING ANY PARTS, DISCONNECT THE UNIT FROM THE ELECTRIC POWER SUPPLY.

**CAUTION:** BE SURE ALL OPERATORS READ, UNDERSTAND AND FOLLOW THE OPERATING INSTRUCTIONS, CAUTIONS, AND SAFETY INSTRUCTIONS CONTAINED IN THIS MANUAL.

**WARNING:** THIS UNIT IS INTENDED FOR USE IN THE COMMERCIAL HEATING, COOKING AND HOLDING OF WATER AND FOOD PRODUCTS, PER THE INSTRUCTIONS CONTAINED IN THIS MANUAL. THIS EQUIPMENT IS NOT FOR CONTINUOUS MASS PRODUCTION OF FOOD PRODUCTS OR ANY OTHER USE COULD RESULT IN SERIOUS PERSONAL INJURY OR DAMAGE TO THE EQUIPMENT AND WILL VOID WARRANTY.

**WARNING:** KETTLE MUST BE INSTALLED BY PERSONNEL QUALIFIED TO WORK WITH ELECTRICITY AND PLUMBING. IMPROPER INSTALLATION CAN RESULT IN INJURY TO PERSONNEL AND/OR DAMAGE TO EQUIPMENT.

**DANGER:** ELECTRICALLY GROUND THE UNIT AT THE TERMINAL PROVIDED. FAILURE TO GROUND UNIT COULD RESULT IN ELECTROCUTION AND DEATH.

**WARNING:** AVOID ALL DIRECT CONTACT WITH HOT EQUIPMENT SURFACES. DIRECT SKIN CONTACT COULD RESULT IN SEVERE BURNS.

**WARNING:** AVOID ALL DIRECT CONTACT WITH HOT FOOD OR WATER IN THE KETTLE. DIRECT CONTACT COULD RESULT IN SEVERE BURNS.

**CAUTION:** DO NOT OVER FILL THE KETTLE WHEN COOKING, HOLDING OR CLEANING. KEEP LIQUIDS A MINIMUM OF 2-3” (5-8 cm) BELOW THE KETTLE BODY RIM TO ALLOW CLEARANCE FOR STIRRING, BOILING AND SAFE PRODUCT TRANSFER.

**WARNING:** TAKE SPECIAL CARE TO AVOID CONTACT WITH HOT KETTLE BODY OR HOT PRODUCT WHEN ADDING INGREDIENTS, STIRRING OR TRANSFERRING PRODUCT TO ANOTHER CONTAINER.

**WARNING:** WHEN TILTING KETTLE FOR PRODUCT TRANSFER:

- 1) USE CONTAINER DEEP ENOUGH TO CONTAIN AND MINIMIZE PRODUCT SPLASHING.
- 2) PLACE CONTAINER ON STABLE, FLAT SURFACE, AS CLOSE TO KETTLE AS POSSIBLE.
- 3) DO NOT OVER FILL CONTAINER. AVOID DIRECT SKIN CONTACT WITH HOT CONTAINER AND ITS CONTENTS.

**CAUTION:** KEEP FLOORS IN FRONT OF KETTLE WORK AREA CLEAN AND DRY. IF SPILLS OCCUR, CLEAN IMMEDIATELY, TO AVOID SLIPS OR FALLS.

**WARNING:** FAILURE TO CHECK PRESSURE RELIEF VALVE OPERATION PERIODICALLY COULD RESULT IN PERSONAL INJURY AND/OR DAMAGE TO EQUIPMENT.

**WARNING:** DO NOT CONNECT ANY PIPING TO THE PRESSURE RELIEF VALVE. IT MUST BE FREE TO VENT STEAM AS NEEDED. TO AVOID BURNS FROM THE VENTED STEAM THE VALVE DISCHARGE SHOULD POINT DOWNWARD. IMPROPER INSTALLATION WILL VOID WARRANTY.

**WARNING:** DO NOT STAND OR APPLY UNNECESSARY WEIGHT OR PRESSURE ON THE KETTLE FRONT OR POURING LIP. THIS COULD RESULT IN THE OVERLOAD AND FAILURE OF THE TILT MECHANISM, AND POSSIBLE SERIOUS INJURY AND BURNS TO THE OPERATOR AND OTHERS.

**NOTICE:** DO NOT USE A CLEANING, DE-LIMING, OR DEGREASER AGENT THAT CONTAINS ANY SULFAMIC ACID, CHLORIDE, HYDROCHLORIC ACID, POTASSIUM AND SODIUM HYDROXIDE OR THAT IS ALKALINE. IF CONTENTS OF ANY PRODUCT IS UNCLEAR, CONSULT THE MANUFACTURER.

**NOTICE:** NEVER LEAVE SANITIZER IN CONTACT WITH STAINLESS STEEL SURFACES LONGER THAN 10 MINUTES. LONGER CONTACT CAN CAUSE CORROSION.

**WARNING:** WHEN TESTING, AVOID ANY EXPOSURE TO THE STEAM BLOWING OUT OF THE PRESSURE RELIEF VALVE. DIRECT CONTACT COULD RESULT IN SEVERE BURNS.

**WARNING:** TO AVOID INJURY, READ AND FOLLOW ALL PRECAUTIONS STATED ON THE LABEL OF THE WATER TREATMENT COMPOUND.

**WARNING:** KEEP WATER AND SOLUTIONS OUT OF CONTROLS AND ELECTRICAL EQUIPMENT. NEVER USE A WATER JET SPRAY, HIGH PRESSURE HOSE OR STEAM TO CLEAN KETTLE SURFACES.

**CAUTION:** MOST CLEANERS ARE HARMFUL TO THE SKIN, EYES, MUCOUS MEMBRANES AND CLOTHING. PRECAUTIONS SHOULD BE TAKEN. WEAR RUBBER GLOVES, GOGGLES OR FACE SHIELD AND PROTECTIVE CLOTHING. CAREFULLY READ THE WARNINGS AND FOLLOW THE DIRECTIONS ON THE LABEL OF THE CLEANER TO BE USED.

**CAUTION:** USE OF ANY REPLACEMENT PARTS OTHER THAN THOSE SUPPLIED BY THE MANUFACTURER OR AN AUTHORIZED DISTRIBUTOR CAN CAUSE OPERATOR INJURY AND DAMAGE TO THE EQUIPMENT, AND WILL VOID ALL WARRANTIES.

**IMPORTANT:** SERVICE PERFORMED BY OTHER THAN FACTORY AUTHORIZED PERSONNEL WILL VOID WARRANTIES.

**WARNING:** DO NOT HEAT AN EMPTY KETTLE. EXCESSIVE STEAM PRESSURE COULD DEVELOP.

**NOTICE:** IT IS RECOMMENDED THAT AN INSTANT-READ THERMOMETER BE USED TO CHECK THE INTERNAL TEMPERATURE THROUGHOUT THE COOKING PROCESS AND AFTER THE COOKING PROCESS HAS BEEN COMPLETED TO ENSURE THE FOOD HAS BEEN COOKED SUFFICIENTLY.

**CAUTION:** THIS APPLIANCE CAN BE USED BY CHILDREN AGED FROM 8 YEARS AND ABOVE AND PERSONS WITH REDUCED PHYSICAL, SENSORY OR MENTAL CAPABILITIES OR LACK OF EXPERIENCE AND KNOWLEDGE IF THEY HAVE BEEN GIVEN SUPERVISION OR INSTRUCTION CONCERNING USE OF THE APPLIANCE IN A SAFE WAY AND UNDERSTAND THE HAZARDS INVOLVED.

**CAUTION:** CHILDREN SUPERVISED ARE NOT TO PLAY WITH THIS APPLIANCE.

**CAUTION:** CLEANING AND USER MAINTENANCE SHALL NOT BE MADE BY CHILDREN WITHOUT SUPERVISION.

## PERFORMANCE DATA

Models	Kettle Capacity	Jacket Capacity	Kettle Body Diameter	Kettle Body Depth	Base Width	Base Depth
TDB/TDBC-20 (C,A)	5 Gal. (20 Qt.)	7 Qt	14 inches	11 inches	24 inches	16 inches
	18.9 liter	6.6 liter	356 mm	279 mm	610 mm	406 mm
TDB/TDBC-24 (C,A)	6 Gal. (24 Qt.)	7 Qt	14 inches	12-1/2 inches	24 inches	16 inches
	22.7 liter	6.6 liter	356 mm	318 mm	610 mm	406 mm

TDB/TDBC-40 (C,A)	10 Gal. (40 Qt.)	9 Qt	16-1/2 inches	14-1/4 inches	28 inches	16 inches
	37.8 liter	8.5 liter	419 mm	362 mm	711 mm	406 mm
TDB/TDBC-48 (C,A)	12 Gal. (48 Qt.)	9 Qt	16-1/2 inches	16-1/2 inches	28 inches	16 inches
	45.4 liter	8.5 liter	419 mm	419 mm	711 mm	406 mm

## INSPECTION & UNPACKING

- CAUTION:** SHIPPING STRAPS ARE UNDER TENSION AND CAN SNAP BACK WHEN CUT. TAKE CARE TO AVOID PERSONAL INJURY OR DAMAGE TO THE UNIT BY STAPLES LEFT IN THE WALLS OF THE CARTON.
- CAUTION:** THIS UNIT IS VERY HEAVY. INSTALLER SHOULD OBTAIN HELP AS NEEDED TO LIFT THIS WEIGHT SAFELY.

The unit will arrive in a heavy wooden crate and will be bolted or banded to a skid. Immediately upon receipt, inspect the carton carefully for exterior damage.

Carefully cut any polyester straps around the carton and detach the sides of the box from the skid. Pull the carton up off the unit.

Thoroughly inspect the unit for concealed damage. Report any shipping damage or incorrect shipments to the delivery agent.

Write down the model number, serial number, and installation date, and retain this information for future reference. Space for these entries is provided at the top of the Service Log at the back of this manual. Keep this manual on file and available for operators to use.

When installation is to begin, carefully cut any straps which hold the unit on the skid. Lift the unit straight up off the skid. Examine packing materials to be sure loose parts are not discarded with the materials.



## INSTALLATION

**WARNING:** INSTALLATION OF THE KETTLE MUST BE DONE BY A CERTIFIED ELECTRICIAN OR AUTHORIZED REPRESENTATIVE QUALIFIED TO WORK WITH ELECTRICITY. IMPROPER INSTALLATION CAN RESULT IN INJURY TO PERSONNEL AN/OR DAMAGE TO EQUIPMENT.

**DANGER:** ELECTRICALLY GROUND THE UNIT AT THE TERMINAL PROVIDED. FAILURE TO GROUND UNIT COULD RESULT IN ELECTROCUTION AND DEATH.

**CAUTION:** BEFORE ANY ELECTRICAL CONVERSION, VERIFY THAT THE BRANCH CIRCUIT WIRING IS ADEQUATE TO HANDLE ANY INCREASE AMPERAGE REQUIREMENTS. REFER TO THE ELECTRICAL SPECIFICATIONS LISTED BELOW.

**WARNING:** DO NOT CONNECT ANY PIPING TO THE PRESSURE RELIEF VALVE. THE VALVE MUST BE FREE TO VENT STEAM AS NEEDED. IMPROPER INSTALLATION WILL VOID THE WARRANTY! THE ELBOW ATTACHED TO THE SAFETY VALVE MUST POINT TO THE FLOOR. INSTALLATION WILL VOID THE WARRANTY! THE ELBOW ATTACHED TO THE SAFETY VALVE MUST POINT TO THE FLOOR.

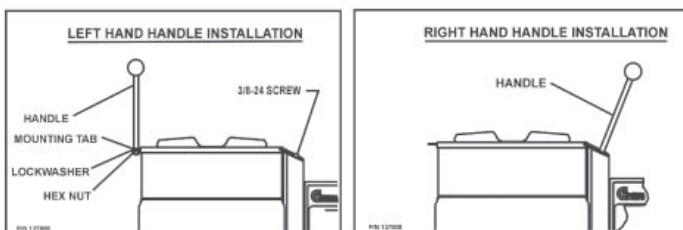

Figure 1



Figure 2

The kettle is provided with complete internal wiring and is ready for immediate connection. Wiring diagrams are provided in this manual and on the inside of

the control housing service panel. Any mechanical or electrical changes must be approved by the Food Service Engineering Department.

The completed unit has been operated at the factory to test all controls and heater elements.

1. Set the kettle in place and level it. The base should be securely fastened to a table or work surface. Four 3/8-16 N. C. threaded couplings are provided in the base of unit. Installation under ventilation hood is recommended.
2. Once the unit is anchored to mounting surface, apply a small bead of silicone caulk around the perimeter of the kettle base and seal joint.
3. Confirm that the jacket water level is at the mid point of sight glass. If the level is low, follow the instructions under "Jacket Filling and Water Treatment," in this manual.
4. The open end of the elbow on the outlet of the pressure relief valve must face downward. If it does not, turn it to the correct position.
5. Provide electrical power specified on the equipment electrical information plate.
6. Bringing the electrical service through the entrance at the rear of the support housing with one inch conduit, making a watertight connection with the incoming lines.
7. Electrically protective earth ground the unit at the terminal provided (figure 1).
8. This unit is fitted with an equipotential terminal in accordance with national regulations and CE directives. Locate this marking for equipotential terminal connection (figure 2).
9. Check the following to confirm that your kettle is properly installed:
  - Room for cleaning and servicing
  - The kettle is level
  - The correct amount of water is in the kettle jacket
  - Pressure relief valve is pointed down
  - Unit is connected with a waterproof supply of the proper voltage, phase and amperage rating

### TDB(C) ELECTRICAL SPECIFICATIONS

**WARNING:** USE COPPER WIRE RATED AT LEAST 75°C (UNDER "ELECTRICAL SPECIFICATIONS").

ELECTRICAL SUPPLY CONNECTION REQUIREMENTS			20/24 QUARTS 19/23 LITERS			40/48 QUARTS 38/45 LITERS		
Voltage	Phase	Neutral	kW	Amps	Min. Wire Gauge	kW	Amps	Min. Wire Gauge
230	1	YES	7.8	33	10 AWG (6 mm <sup>2</sup> )	13.3	57	8 AWG (10 mm <sup>2</sup> )
400	3 N	YES	7.8	11.2	14 AWG (2.5 mm <sup>2</sup> )	13.3	19	14 AWG (2.5 mm <sup>2</sup> )

## INITIAL START-UP

**IMPORTANT:** BE SURE ALL OPERATORS READ, UNDERSTAND AND FOLLOW THE OPERATING INSTRUCTIONS, CAUTIONS, AND SAFETY INSTRUCTIONS CONTAINED IN THIS MANUAL.

**WARNING:** AVOID ALL DIRECT CONTACT WITH HOT SURFACES. DIRECT SKIN CONTACT COULD RESULT IN SEVERE BURNS. AVOID ALL DIRECT CONTACT WITH HOT FOOD OR WATER IN THE KETTLE. DIRECT CONTACT COULD RESULT IN SEVERE BURNS.

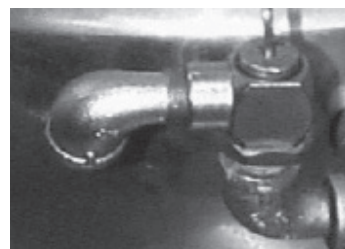

The open end of the pressure relief valve elbow must face downward.

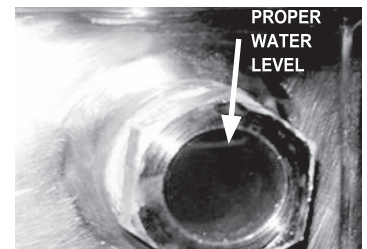

Correct water level.



Now that the kettle has been installed, you should test it to ensure that the unit is operating correctly.

1. Remove all literature and packing materials from inside and outside of the unit.
2. If the unit is equipped with a draw-off valve (product outlet), clean out any material which might clog or damage the draw-off.
3. Confirm that the tilting mechanism is operating properly by tilting the kettle through its full range. Then return the kettle to the upright position.
4. Turn on the electrical service to the unit.
5. Pour 1-2 (.95-1.89 liters) quarts of water into the kettle.
6. Following "To Start Kettle" instructions in the "Operation" section of this manual, begin heating the water at the highest thermostat setting. The heating indicator light should come on immediately, and heating should continue until the water boils.
7. To shut down the unit, turn the power switch to "OFF".

If the unit functions as described above, it is ready for use. If the unit does not function as intended, first recheck power supply connections and, if necessary, contact your local Certified Service Agency.

## OPERATION

### WARNING: WHEN TILTING KETTLE:

- 1) WEAR PROTECTIVE OVEN MITT AND PROTECTIVE APRON.
- 2) USE DEEP CONTAINER TO CONTAIN AND MINIMIZE PRODUCT SPLASHING.
- 3) PLACE CONTAINER ON STABLE, FLAT SURFACE, AS CLOSE TO KETTLE AS POSSIBLE.
- 4) STAND TO RIGHT OF KETTLE WHILE POURING — NOT DIRECTLY IN POUR PATH OF HOT CONTENTS.
- 5) POUR SLOWLY, MAINTAINING CONTROL OF KETTLE, AND RETURN KETTLE BODY TO UPRIGHT POSITION AFTER CONTAINER IS FILLED OR TRANSFER IS COMPLETE.
- 6) DO NOT OVERFILL CONTAINER. AVOID SKIN CONTACT WITH HOT CONTAINER AND ITS CONTENTS.

WARNING: DO NOT EMPTY CONTENTS FROM KETTLE UNTIL PRESSURE REDUCES OR READS APPROXIMATELY ATMOSPHERIC PRESSURE.

WARNING: OPENING TANGENT DRAW OFF (TDO) VALVE WILL LEAD TO THE DISCHARGE OF HOT CONTENTS.

WARNING: AVOID ALL DIRECT CONTACT WITH HOT SURFACES AND HOT FOOD OR WATER IN THE KETTLE. DIRECT CONTACT COULD RESULT IN SEVERE BURNS.

CAUTION: DO NOT OVERFILL THE KETTLE WHEN COOKING, HOLDING OR CLEANING. KEEP LIQUIDS AT LEAST 2-3" (5-8 CM) BELOW THE KETTLE RIM TO ALLOW CLEARANCE FOR STIRRING, BOILING AND SAFE PRODUCT TRANSFER.

WARNING: AVOID ALL DIRECT CONTACT WITH HOT FOOD OR WATER IN THE KETTLE. DIRECT CONTACT COULD RESULT IN SEVERE BURNS.

CAUTION: HEATING AN EMPTY KETTLE MAY CAUSE THE RELEASE OF STEAM FROM THE PRESSURE RELIEF VALVE.

CAUTION: DO NOT TILT KETTLE BODY WITH COVER OR BASKET INSERT IN PLACE. COVER MAY SLIDE OFF, CAUSING INJURY TO OPERATOR.

CAUTION: ANY POTENTIAL USER OF THE EQUIPMENT MUST BE TRAINED IN SAFE AND CORRECT OPERATING PROCEDURES.

WARNING: KEEP AREA AROUND KETTLE FREE AND CLEAR OF ALL COMBUSTIBLE MATERIALS.



Classic Control



Advanced Control

## CONTROLS

### 1. Classic Control (-C) Models

- a. Lighted Power ON switch located on the control console. Controls main power to the unit.
- b. The temperature knob, located on the control console, is used to set the kettle heat values between 1 and 10.
- c. Heating indicator light located on the control console, lights when the controller energizes the heating elements and will cycle on and off once the unit reaches set temperature. If the unit is tilted, the heating elements will be disabled and the light will turn off until the unit is returned to the cooking position.
- d. A LOW WATER indicator light, located on the control console, illuminates when the jacket water falls below acceptable levels. When lit, the heating elements are disabled and will not function until the jacket water is refilled using the procedure in this manual.
- e. Crank tilt - a handle controls the worm and gear mechanism that smoothly tilts the kettle body and holds it in the desired position.

### 2. Advanced Control (-A) Models

- a. Lighted Power ON switch located on the control console. Controls main power to the unit.
- b. The temperature knob, located on the control console, is used to set the kettle heat values between 1.0 and 10.0. The current setting will be reflected on the display.
- c. Heating indicator light located on the control console, lights when the controller energizes the heating elements and will cycle on and off once the unit reaches set temperature. If the unit is tilted, the heating elements will be disabled and the light will turn off until the unit is returned to the cooking position.
- d. A LOW WATER indicator light, located on the control console, illuminates when the jacket water falls below acceptable levels. When lit, the heating elements are disabled and will not function until the jacket water is refilled using the procedure in this manual.
- e. SET TnnP Mode - Allows power to the controller without the kettle heating; the kettle will heat once the LOW TEMP, MANUAL or HIGH TEMP button is selected.
- f. LOW TEMP Button – Used to set operating temperature of the kettle at a preset low intensity (default = 2.0). Can be pressed at any time during operation of the unit to change the set temperature to the preset value except when there is an active TIMER enabled.
- g. MANUAL Mode button – Enables the user modify the desired cooking temperature of the kettle (between 1.0 and 10.0) using the temperature knob and display (default = 5.0). The operator will press the MANUAL button and set the desired temperature using the temperature knob and display. Once the desired temperature is reached, the user may

- either press the MANUAL button again or wait 5 seconds and the set temperature will be accepted by the controller and locked in. After the set temperature is accepted, it may be changed at any time by pressing the MANUAL button and resetting the temperature using the same process above.
- h. HIGH TEMP button – Used to set operating temperature of the kettle at a preset high intensity (default = 7.0). Can be pressed at any time during operation of the unit to change the set temperature to the preset value except when there is an active TIMER enabled.
  - i. TIMER button - once the appropriate set temperature is selected using the HIGH TEMP, MANUAL or LOW TEMP buttons; a countdown timer can be set to remind the user when the cooking process is completed.
    1. Range – 1 minute to 10 hours
    2. When the timer expires:
      - a. the set temperature will automatically change to the LOW TEMP setting and will continue at this setting until the user changes the temperature via MANUAL or HIGH TEMP buttons
      - b. An audible alarm will notify the user that attention is required, the alarm will continue to sound until the user presses the TIMER button.
    3. An active timer can be cancelled by pressing and holding the TIMER button for 5 secs.
    4. Set temp can be changed during an active timer by pressing the MANUAL button and adjusting the set temp using the Temperature knob and display.
    5. HIGH TEMP and LOW TEMP presets cannot be used to change the setpoint once a TIMER has started.
  - j. READY alarm – The control will sound 3 beeps when the unit has reached within 20 degrees of set point during pre-heat and when a higher set temperature is selected.
  - k. Crank tilt - a handle controls the worm and gear mechanism that smoothly tilts the kettle body and holds it in the desired position.
- e. Press the MANUAL button and turn the temperature knob to the desired setting using the display (if a temperature is not selected after the MANUAL button is pressed, the kettle will default to a heat setting of 5.0). The heating indicator light indicates that the kettle is heating, and cycling of the on and off indicates that the kettle is being held at the set temperature. Once in each cycle the contactors in the support housing will make a clicking sound. This is normal.

3. To Transfer Product or Empty Kettle:

- a. TDB: The kettle is designed and manufactured to be tilted in a controlled manner. Grasp the insulated plastic ball firmly. Maintain a firm grip on handle when tilting, while keeping the kettle body in a tilted position and slowly return the kettle body to an upright position. DO NOT release handle when kettle is partly tilted. It will impact in either the upright or fully tilted position and may cause burns.
- b. TDBC: The kettle is tilted using its crank tilt hand wheel. Turning the crank clockwise tilts the kettle; counter-clockwise returns it to an upright position. The kettle will remain in any cranked position.

4. To Stop Kettle Heating:

- a. Turn temperature dial to OFF.
- b. For a prolonged shut-down:
  - 1) Follow the procedure above.
  - 2) Disconnect electric power from the unit.

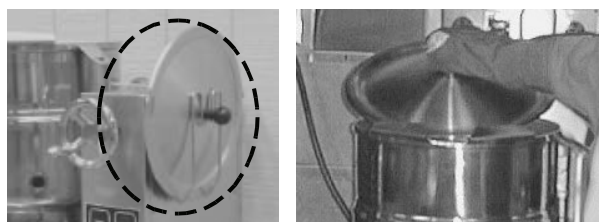

Lift the rear of the lid first.

**OPERATING PROCEDURE**

1. To Start Kettle Heating with Classic Controls:

- a. EVERY DAY make sure that the jacket water level in the middle of the sight glass. If the level is too low, see “Jacket Filling and Water Treatment” in this manual.
- b. Check the pressure/vacuum gauge. If the gauge does not show -20 to -30 inches of mercury (Hg) vacuum or a range of -0.7 to -1.0 Bar, see “Jacket Vacuum” in this manual.
- c. Turn on the electrical power to the unit.
- d. Turn on the main power switch on the control face.
- e. Turn the temperature knob to the desired setting. The heating indicator light indicates that the kettle is heating, and cycling of the on and off indicates that the kettle is being held at the set temperature. Once in each cycle the contactors in the support housing will make a clicking sound. This is normal.

2. To Start Kettle Heating with Advanced:

- a. EVERY DAY make sure the jacket water level is above the mid-point of the round sight glass. If the level is too low, see “Jacket Filling” and “Water Treatment” in this manual.
- b. Check the pressure gauge. If the gauge does not show -20 to -30 inches of mercury (Hg) vacuum or a range of -0.7 to -1.0 Bar, see “Jacket Filling” and “Water Treatment” in this manual.
- c. Turn on the electrical power to the unit.
- d. Turn on the main power switch on the control face, controller will show SET TnnP in the display.

**USE OF COMMON ACCESSORIES**

1. Lift-Off Cover:

- a. As with stock pot cooking, an optional cover can speed up the heating of water and food products. It helps retain heat and reduces the heat and humidity in the kitchen. A cover can reduce some product cook times and help maintain the temperature, color and texture of products held or simmered for longer periods.
- b. Be sure the handle is secure on the lift-off cover before using. ALWAYS use the handle to place or remove cover from the kettle. Wear protective oven mitts and apron.
- c. When putting the cover on the kettle, position it on top of kettle rim, with its flat edge facing the pouring lip.
- d. When removing cover:
  - 1) Firmly grasp plastic handle.
  - 2) Lift rear edge (farthest from operator) 1-2” (3-5 cm) to allow any steam and water vapor to escape the cooking vessel. Wait 2-3 seconds.
  - 3) Tilt cover to 45-60° angle and allow any hot condensate or product to roll off cover back into kettle.
  - 4) Remove cover, ensuring that any remaining hot condensate or product does not drip on operator, floor or work surfaces.
  - 5) Place cover on safe, flat, sanitary, out-of-the-way surface, or return to kettle rim.

## 2. Basket Insert

An optional kettle basket insert can assist in cooking water-boiled products including eggs, potatoes, vegetables, shell fish, pasta and rice. The nylon mesh liner must be used when cooking product smaller than the mesh size of the basket, which is approximately 1/4" (6 mm). This includes rice and small pasta shapes. Tips for use:

- Allow for the water displacement of the basket and product to be cooked. This may mean only filling the kettle half full of water. Test the basket and product displacement with the kettle OFF, and with cold water in the kettle.
- Load baskets on a level, stable work surface.
- Lift loaded baskets with both hands. Get help from another person if the basket is too heavy for safe handling.
- Slowly lower product into kettle.
- When removing baskets with cooked product, lift straight up, ensuring basket bottoms clear the kettle rim and pouring lip. Wear protective oven mitts and protective apron.
- Allow hot water to fully drain from product before moving basket away from the kettle. Do not rest baskets on kettle rim or pouring lip. If baskets are too heavy for individual to lift and safely move, get help. Remove product immediately from basket into another container, being sure to avoid contact with hot product and hot basket or...
- Place baskets with food on a stable, flat surface, inside a solid steamer or bake pan, to catch any remaining hot water draining from product.

## CLEANING

**WARNING: KEEP WATER AND SOLUTIONS AWAY FROM CONTROLS AND ELECTRICAL EQUIPMENT. NEVER SPRAY THE SUPPORT HOUSING OR ELECTRICAL CONNECTIONS.**

**CAUTION: MOST CLEANERS ARE HARMFUL TO THE SKIN, EYES, MUCOUS MEMBRANES, AND CLOTHING. PRECAUTIONS SHOULD BE TAKEN. WEAR RUBBER GLOVES, GOGGLES OR FACE SHIELD, AND PROTECTIVE CLOTHING. READ THE WARNINGS AND FOLLOW THE DIRECTIONS ON THE LABEL OF THE CLEANER CAREFULLY.**

**CAUTION: NEVER LEAVE A SANITIZER IN CONTACT WITH STAINLESS STEEL SURFACES LONGER THAN 30 MINUTES. LONGER CONTACT CAN CAUSE CORROSION.**

**WARNING: AVOID DIRECT CONTACT WITH HOT SURFACES. DIRECT SKIN CONTACT COULD RESULT IN SEVERE BURNS.**



Use a brush, sponge, cloth, plastic or rubber scraper, or plastic wool to clean.



Don't use metal implements or steel wool when cleaning.



### SUGGESTED CLEANING SUPPLIES

- Cleaner, such as Klenzade HC-10 or HC-32 from ECOLAB, Inc. or equivalent.
- Kettle brushes in good condition
- Sanitizer such as Klenzade XY-12.
- Film remover such as Klenzade LC-30.

## PRECAUTIONS

Before cleaning, shut off the kettle by turning the main power switch to "OFF," and shut off all electric power to the unit at a remote switch, such as the circuit breaker.

## PROCEDURE

- Clean food-contact surfaces as soon as possible after use. If the unit is in continuous use, thoroughly clean and sanitize the interior and exterior at least once every 12 hours.
- Scrape and flush out food residues. Be careful not to scratch the kettle with metal implements.
- Prepare a hot solution of the detergent/cleaning compound as instructed by the supplier. Clean the unit thoroughly. A cloth moistened with cleaning solution can be used to clean controls, housings, and electrical conduits.
- Rinse the kettle and draw-off valve parts thoroughly with hot water, then drain completely.
- As part of the daily cleaning program, clean soiled external and internal surfaces. Remember to check the sides of the unit and control housing, underside of cover, etc.
- To remove burnt on foods, use a brush, sponge, cloth, plastic or rubber scraper, or plastic wool with the cleaning solution. To reduce effort required in washing, let the detergent solution sit in the kettle and soak into the residue. Do NOT use abrasive materials or metal tools that might scratch the surface. Scratches make the surface harder to clean and provide places for bacteria to grow. Do NOT use steel wool, which may leave particles in the surface and cause eventual corrosion and pitting.
- The outside of the unit may be cleaned with a warm water (100°F or less) spray. Do not use a high pressure spray.
- The outside of the unit may be polished with a stainless steel cleaner such as "Zepper" from Zep Manufacturing Co.
- When equipment needs to be sanitized, use a solution equivalent to one that supplies 200 parts per million available chlorine. Obtain advice on sanitizing agents from your supplier of sanitizing products.
- It is recommended that each piece of equipment be sanitized just before use.
- Clean the kettle thoroughly. If there is difficulty removing mineral deposits or a film left by hard water or food residues, then use a de-liming agent, following manufacturer directions.
- Rinse and drain the unit thoroughly before further use.
- If cleaning problems persist, contact your cleaning product representative for assistance. The supplier has a trained technical staff with laboratory facilities to serve you.

## MAINTENANCE

**WARNING: AVOID ANY EXPOSURE TO THE STEAM BLOWING OUT OF THE PRESSURE RELIEF VALVE. SEVERE BURNS CAN RESULT ON EXPOSED SKIN. FAILURE TO CHECK PRESSURE RELIEF VALVE OPERATION PERIODICALLY COULD RESULT IN PERSONAL INJURY AND/OR DAMAGE TO EQUIPMENT.**

**CAUTION: KEEP GREASE AWAY FROM ELECTRICAL PARTS LOCATED NEAR THE GEARS.**

**WARNING: TO AVOID INJURY, READ AND FOLLOW ALL PRECAUTIONS STATED ON THE LABEL OF THE WATER TREATMENT COMPOUND.**

**WARNING: USE OF ANY REPLACEMENT PARTS OTHER THAN THOSE SUPPLIED BY THE MANUFACTURER OR THEIR AUTHORIZED DISTRIBUTORS CAN CAUSE INJURY TO THE OPERATOR AND DAMAGE TO THE EQUIPMENT AND WILL VOID ALL WARRANTIES.**

**CAUTION: INSURE ELECTRICAL POWER IS REMOVED AND THE GAS IS TURNED OFF AT THE SHUTOFF VALVE PRIOR TO PERFORMING ANY MAINTENANCE ON THIS KETTLE.**

**WARNING: THIS KETTLE IS DESIGNED TO BE WATER RESISTANT. FAILURE TO FOLLOW PROPER MAINTENANCE PROCEDURES MAY VOID THE WARRANTY.**

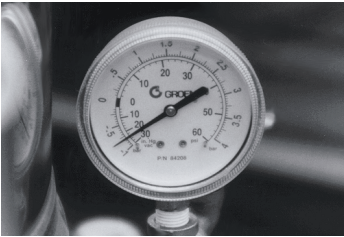

The pressure gauge should show a vacuum of -20 to -30 inches of mercury (Hg) vacuum or a range of -0.7 to -1.0 Bar when the kettle is cold.

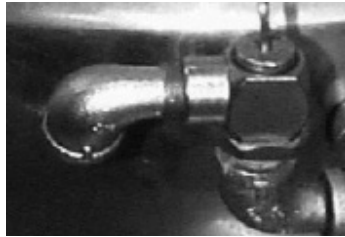

The open end of the pressure relief valve elbow must face downward.

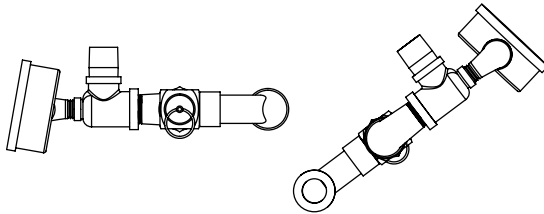

The pressure relief valve is located directly behind the pressure/vacuum gauge.

## PERIODIC MAINTENANCE

**NOTICE:** Contact an authorized representative when repairs are required.

A Maintenance & Service Log is provided at the back of this manual. Each time maintenance is performed on your kettle, enter the date on which the work was done, what was done, and who did it. Keep this manual on file and available for operators to use. Periodic inspection will minimize equipment down time and increase the efficiency of operation. The following points should be checked:

[BY OPERATOR]

1. Check the pressure/vacuum gauge every day. The gauge should show a vacuum of -20 to -30 inches of mercury (Hg) vacuum or a range of -0.7 to -1.0 Bar, see "Jacket Vacuum" in this manual.
2. Also check the jacket water level every day. It should be between the marks on the gauge glass. If the level is low, see "Jacket Filling and Water Treatment" in this manual.
3. Carefully test the pressure relief valve at least twice each month. With the kettle operating at 15 psi (105 kPa, 1.1 bar), pull the test lever and let it snap back to its closed position. If there is little discharge (mostly air), and the pressure gauge drops back to 0 psi (0 kPa, 0 bar), allow the pressure to build back to 5 psi (35 kPa, 0.34 bar) and repeat the procedure. (Tip: Using a screwdriver or other implement to pull the ring will help you avoid contact with the steam.)

[BY SERVICE TECHNICIAN]

4. Electrical wiring should be kept securely connected and in good condition.
5. The inside of the support housing should be kept clean.
6. At least twice a year, grease the two trunnion bearings. The bearings are located within the kettle support housing. Remove the access panels from the support housing with a screwdriver to gain access to the grease fittings. Use a lithium-based, multi-purpose grease. When the access panels are removed, the mounting bolts for the trunnion bearings and tilt switch can also be checked for tightness.
7. On the crank-tilt models, the gear housing has fittings for proper lubrication of moving parts. Because the gears do not run in oil, periodic lubrication with grease is necessary. Frequency of lubrication will depend on operating conditions, but the service should be performed at least once every six months.
8. Use a #2 grade LGI lithium grease to add grease through Zerk fittings on gear housing until it flows out of the bearings around the trunnion shaft.
9. Place liberal amounts of grease on the gear to cover the arc that is in contact with the worm gear.

10. Keep electrical wiring and connections in good condition.

11. Keep the inside of the control console clean and dry.

## JACKET VACUUM/REMOVING AIR FROM JACKET

When the kettle is cold, a positive pressure reading on the pressure/vacuum gauge or a reading near 0 psi (0 kPa, 0 bar) indicates that there is air in the jacket. Air in the jacket acts as an insulator, and slows kettle heating.

To remove air:

1. Start the unit. (Be sure there is water or product in the kettle when heating).
2. When the pressure/vacuum gauge reaches a positive pressure reading of 5 psi (35 kPa, 0.34 bar), release the trapped air and steam by pulling up the safety valve ring for about five seconds. Repeat this step three or four times. Then let the pull ring snap back into the closed position.
3. If there is little discharge (mostly air), and the pressure gauge drops back to 0 psi (0 kPa, 0 bar), allow the pressure to build back to 5 psi (35 kPa, 0.34 bar) and repeat the procedure.
4. Once steam has been vented from the jacket as described in b, above, remove the hot water from the kettle and replace it with cold. This will condense steam in the kettle jacket, and the pressure gauge should show -20 to -30 inches of mercury (Hg) vacuum or a range of -0.7 to -1.0 Bar. If it does not, or if the vacuum is leaking down, contact an authorized service agency to correct the problem.

## PRESSURE RELIEF VALVE

At least twice a month, test the pressure relief valve. Test the valve with the kettle operating at 15 PSI (105 kPa, 1.1 bar), by holding the test ring for at least five seconds. Then release the ring and permit the valve to snap shut. If the ring does not activate, if there is no discharge, or if the valve leaks, stop using the kettle immediately and contact a authorized service representative.

## JACKET FILLING

The jacket was charged at the factory with the proper amount of treated water. You may need to restore this water, either because it was lost as venting steam or by draining. If you are replacing water lost as steam, use distilled water. If you are replacing treated water that ran out of the jacket, prepare more treated water as directed in "Water Treatment Procedure," below.

1. Allow the kettle to cool completely. The procedure will be easier with the kettle under vacuum (pressure gauge reading below zero).
2. Allow the kettle to cool completely. Remove the elbow and pressure relief with an open-end wrench or crescent wrench. Pour in the distilled or treated water. Using a funnel will help you in this process. Continue adding water until the water level rises to the center of the round sight glass.
3. Position a funnel in the opening and fill it with properly treated water.
4. Apply teflon tape in a clockwise pattern and reinstall the pressure relief.
5. Air that gets into the jacket during the filling operation must be removed, because it will make heating less efficient. Follow the procedure in Jacket Vacuum/Removing Air From Jacket above, to restore a negative pressure reading.

## WATER TREATMENT

1. Obtain water treatment compound and a pH test kit from your authorized parts distributor.
2. Fill a mixing container with the measured amount of water required. (See table). Distilled water is recommended.

Model	Kettle Capacity	Jacket Capacity
TDB/TDBC-20	20 qt (5 gal), 18.9 liter	7 quart, 6.6 liter
TDB/TDBC-24	24 qt (6 gal), 22.7 liter	7 quart, 6.6 liter
TDB/TDBC-40	40 qt (10 gal), 37.8 liter	9 quart, 8.5 liter
TDB/TDBC-48	48 qt (12 gal), 45.4 liter	9 quart, 8.5 liter

- Hang a strip of pH test paper on the rim of the container, with about 1 inch of the strip below the surface of the water.
- Measure the water treatment compound (One way to do this is to add the compound from a measuring cup.)
- Stir the water continuously, while you slowly add water treatment compound, until the water reaches a pH between 10.5 and 11.5. Judge the pH by frequently comparing the test strip color with the color chart provided in the pH test kit. If you are color blind use an electroanalytical instrument to measure the pH level or have a person who is not color blind read the test strip color level.
- Record the exact amounts of water and treatment compound used. These amounts may be used again, if the same water sources and compound are used in the future. However, it is best to check the pH each time treated water is prepared.

## SEQUENCE OF OPERATION

The following “action-reaction” outline is provided to help understand how the kettle works.

When the operator starts up the kettle by turning the power switch “ON” and heat knob from “OFF” to a desired setting, the control relay closes. This lights up the heating indicator light and causes the contactors to close, allowing power to flow to heating elements.

When the temperature of the steam jacket reaches the value corresponding to the heat setting, the control relay opens. This turns off the heating indicator light and causes the contactors to open, stopping the power to the heaters.

As soon as the controller senses that the kettle is cooling below the set point, the control relay closes, the heating indicator light comes on, the contactors close, and the heaters come on again. On-off cycling continues, keeping the kettle at the set temperature.

This is why the heating indicator light cycles on and off during normal operation. Every time the kettle is tilted, the tilt cut-off switch interrupts the power supply to the heaters, so that the heating elements will not operate while not submerged in the jacket water.

If steam pressure greater than 50 psi (345 kPa, 3.45 bar) is generated in the jacket, the safety valve will open and relieve the excess pressure.

If the jacket water level gets too low before the heating elements overheat, the high-limit control will open and shut off power to the elements until the kettle cools.

Setting the power switch dial to “OFF” shuts down all control and heating circuits.

The kettle has the following safety features:

- Low water cutoff relay that will remove power from control and contactors until the jacket water level is corrected.
- High limit pressure switch, set to open at about 46 psi (317 kPa, 3.17 bar) and to shut down the heat until jacket pressure is decreased.
- Pressure relief valve, which will release steam if jacket pressure exceeds 50 psi (345 kPa, 3.45 bar).
- Tilt switch, which shuts off all heat when the kettle is tilted.

## REPLACEMENT PARTS

To order parts, contact your Authorized Service Agent. Supply the model designation, serial number, part description, part number, quantity, and when applicable, voltage and phase.

## CONTACT US

If you have questions pertaining to the content in this manual, contact Groen at 888-994-7636.

## TROUBLESHOOTING

This unit is designed to operate smoothly and efficiently if properly maintained. However, the following is a list of checks to make in the event of a problem. Wiring diagrams are found at the end of this manual. When in doubt, turn unit off and call for service at 888-994-7636. If an item on the check list is marked with (X), it means that the work should be done by an Authorized Service Agent.

SYMPTOM	WHO	WHAT TO CHECK
Display not lit (Advanced)	User	a. That power supply is on.
	Authorized Service Rep Only	b. Fuses, accessible by removing caps on the side of the control box. c. For loose or broken wires. X d. Temperature controller functioning, by listening for a click when the switch opens or closes and verifying LEDs on back of board. X e. Contactor functioning. X
PROB in display (Advanced)	Authorized Service Rep Only	a. For loose or broken wires or damaged/failed RTD probe. X b. PCB board malfunction/failure
HI in display (Advanced)	Authorized Service Rep Only	a. For loose or broken wires or damaged/failed RTD probe. X b. PCB board malfunction/failure
Kettle is hard to tilt	Authorized Service Rep Only	a. Gears for foreign materials, and lubrication. X b. Gears for alignment. X c. Worn gears or broken gears. X
Kettle will not heat, and heating indicator will not come on	User	a. Electric power supply to the unit. (Check the circuit breaker.) b. Water level in jacket.
	Authorized Service Rep Only	c. Control circuit fuses. Replace a blown fuse only with a fuse of the same AMP rating. X d. For loose or broken wires. X e. Tilt cut-off switch. X f. That pressure switch is open. X g. Operation of temperature control. X h. Low water cutoff. X
Kettle will not heat, but heating indicator comes on	Authorized Service Rep Only	a. Temperature control calibration and offsets. X b. Heater elements with ohmmeter for ground short or open element. If element is defective, call service. X
Kettle continues heating after it reaches the desired temperature	User	a. Control knob setting.
	Authorized Service Rep Only	b. Temp control circuit for short. X c. Temp control operation. The contacts should click when the dial is rotated above and below the setting for the temperature of the kettle. X d. Contactor, to determine whether it is energized or stuck. X
Kettle stops heating before it reaches the desired temperature	User	a. Control knob setting.
	Authorized Service Rep Only	b. Temp control calibration and offsets. X c. Temp control operation. The contacts should click when the dial is rotated above and below the setting for the temperature of the kettle. X
Kettle heats slowly	User	a. For air in the jacket. See “Jacket Vacuum” in the “Maintenance” section of this manual.
	Authorized Service Rep Only	b. Heater elements with ohmmeter for ground short or open element. If an element is defective, call service. X c. Voltage of main power source. X
Pressure Relief Valve pops	User	a. For air in the jacket. See “Jacket Vacuum” in the “Maintenance” section of this manual.
	Authorized Service Rep Only	b. Pressure switch setting. X c. Temp control operation. The contacts should click when the dial is rotated above and below the setting for the temperature of the kettle. X d. Pressure relief valve. If the valve pops at pressures below 49 PSI, replace it. e. ontactor, to determine whether it is energized. X
Safety valve leaks a small amount of steam when kettle is operating	User	a. For contamination that prevents seating of the valve. With full pressure in the jacket, pull the lever all the way briefly to blow the valve clean, then let the lever snap back to seat the valve.
	Authorized Service Rep Only	b. Safety valve for defects. Replace any defective valve with an identical valve. X

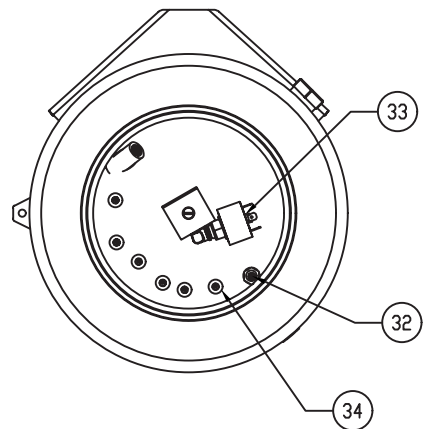
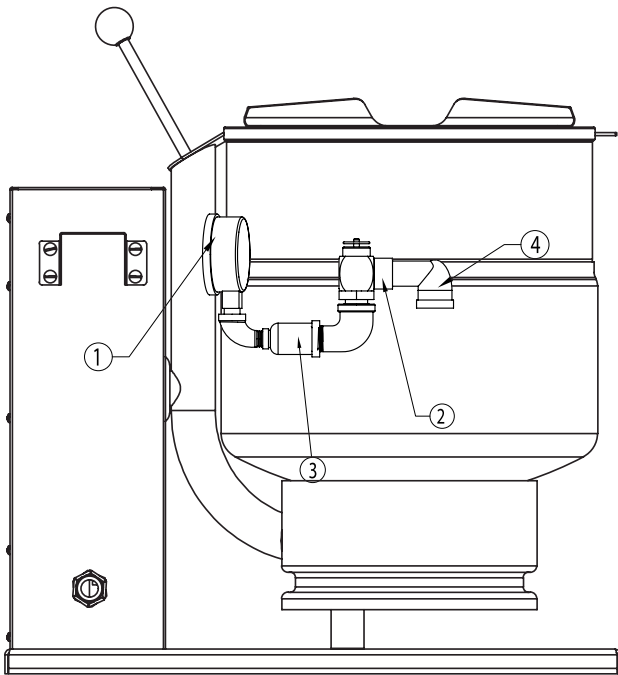
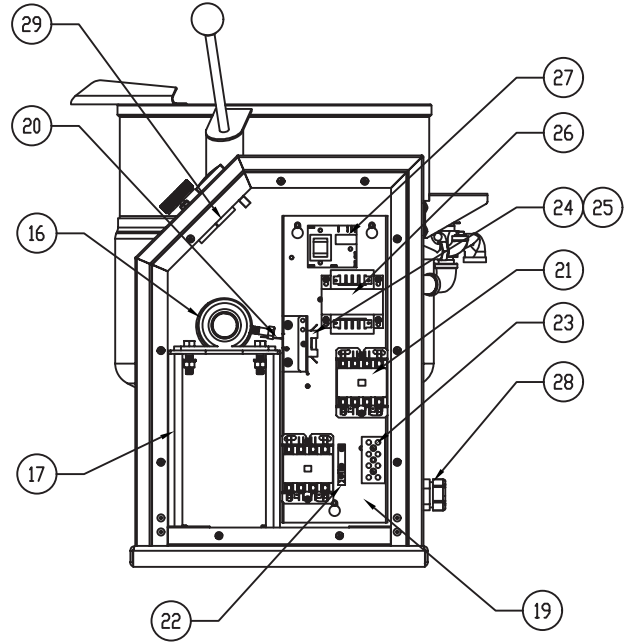
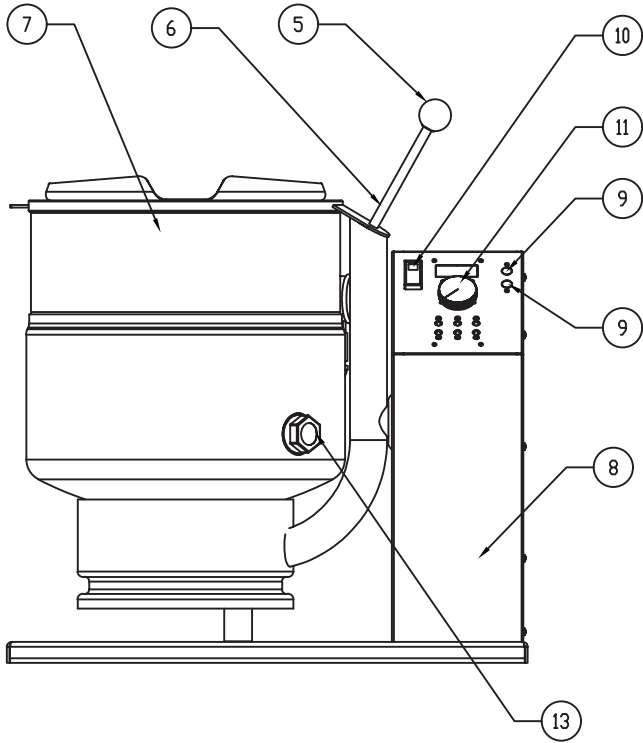

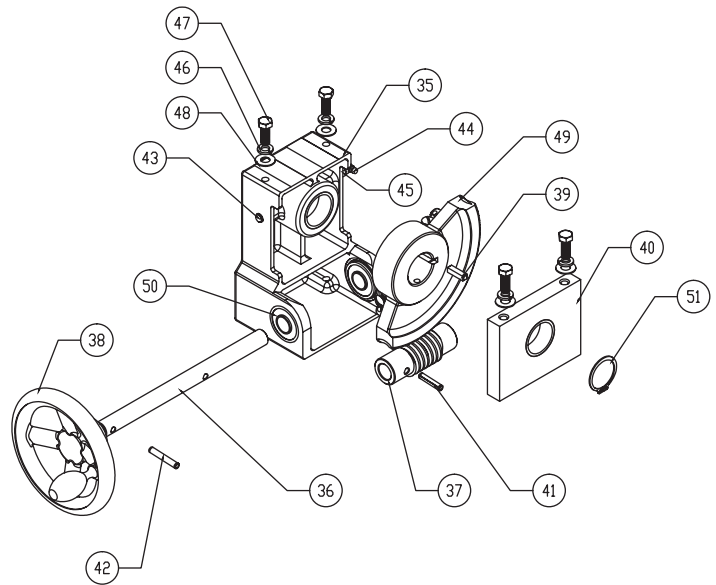
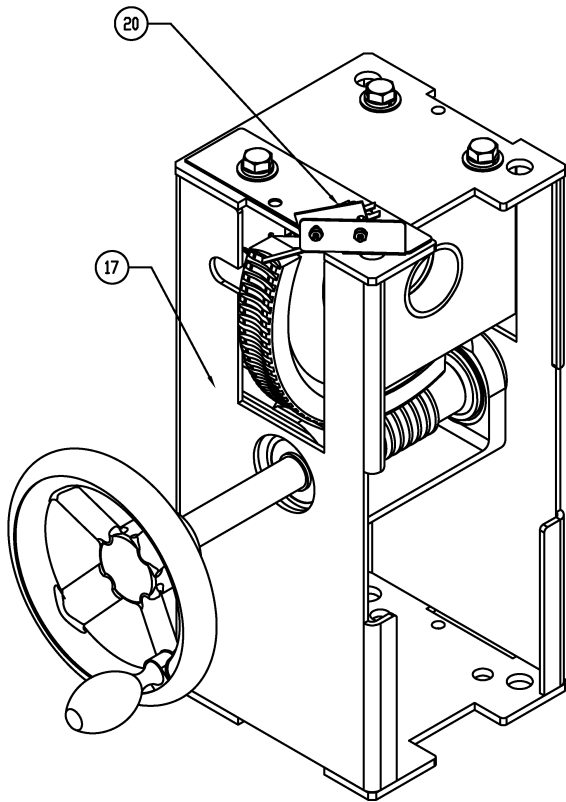
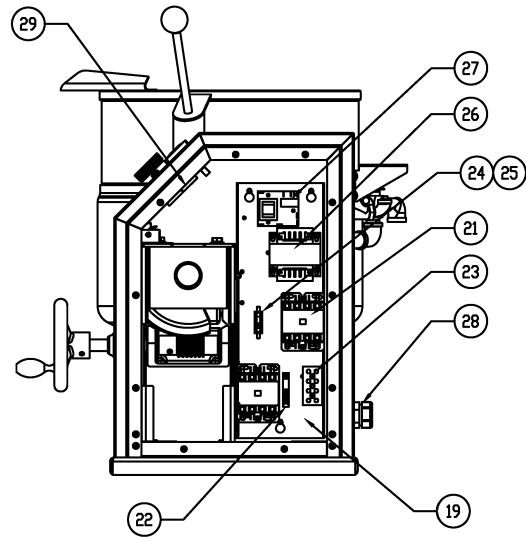
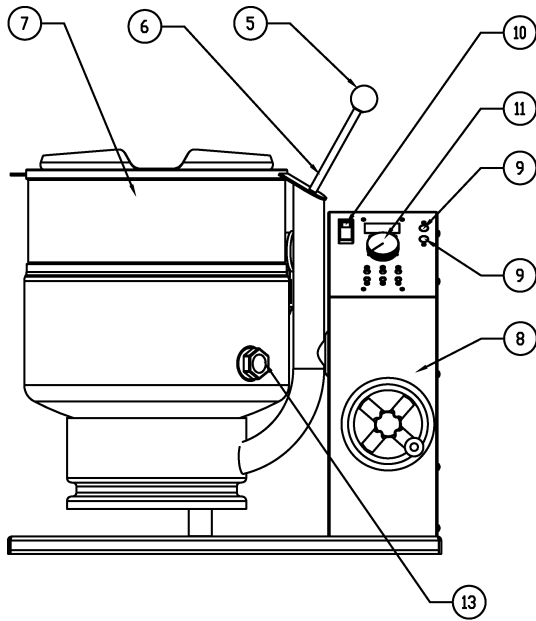

# Parts List

To order parts, contact your Authorized Service Agent. Supply the model designation, serial number, part description, part number, quantity, and when applicable, voltage and phase.

Key	Description	Part No.
1	PRESSURE GAUGE	084208
2	SAFETY VALVE	097005
3	ASSY, WATER FILL SUB	<a href="#">137438</a>
4	ELBOW 90 DEG STREET 1/2 NPT CHROME	010108
5	KNOB	<a href="#">175095</a>
6	HAND & BALL KNOB ASSEMBLY	012694
7	KETTLE BODY ASSEMBLY, 20 QT	175062
7a	KETTLE BODY ASSEMBLY, 20 QT, 480V	175061
7b	KETTLE BODY ASSEMBLY, 24 QT	175067
7c	KETTLE BODY ASSEMBLY, 24 QT, 480V	175068
7d	KETTLE BODY ASSEMBLY, 40 QT	<a href="#">175072</a>
7e	KETTLE BODY ASSEMBLY, 40 QT, 480V	175071
7f	KETTLE BODY ASSEMBLY, 48 QT	175084
7g	KETTLE BODY ASSEMBLY, 48 QT, 480V	175085
8	BASE & PEDESTAL ASSEMBLY - 20/24QT HAND TILT	174752
8a	BASE & PEDESTAL ASSEMBLY - 40/48QT HAND TILT	175362
8b	BASE & PEDESTAL ASSEMBLY - 20/24QT CRANK TILT	175358
8c	BASE & PEDESTAL ASSEMBLY - 40/48QT CRANK TILT	175296
9a	LIGHT, AMBER	<a href="#">116384</a>
9b	LIGHT, RED	<a href="#">116383</a>
10	POWER SWITCH	177910
11A	2" ALUMINUM KNOB, CLASSIC CONTROL	<a href="#">175095</a>
11B	2" ALUMINUM KNOB, ADVANCED & C2T	<a href="#">174829</a>
12	NUT, ROTARY SHAFT SEAL(NOT SHOWN)	<a href="#">101145</a>
13	SIGHT GLASS	<a href="#">108554</a>
14	LIGHT MOUNT BRACKET(NOT SHOWN)	175222
15	LIGHT MOUNT SPACER(NOT SHOWN)	175221
16	HAND TILT MECHANISM ASSEMBLY	<a href="#">137741</a>
17	PEDESTAL WELDMENT - HAND TILT	140321
-	PEDESTAL WELDMENT - CRANK TILT	174630
18	ELECTRICAL MOUNT ASSEMBLY(CRANK TILT) - 208/240V	175229
18a	ELECTRICAL MOUNT ASSEMBLY - 480V	175579
19	ELECTRICAL MOUNT ASSEMBLY(HAND TILT) - 208/240V	175439
19a	ELECTRICAL MOUNT ASSEMBLY - 480V	175440
20	TILT SWITCH	002982
21	CONTACTOR	<a href="#">148102</a>
22	GROUND TERMINAL	<a href="#">129714</a>
23	TERMINAL BLOCK	003888
24	FUSE HOLDER	077854
25	FUSE, 3 AMP	77853
26	TRANSFORMER, 208/240V	<a href="#">137441</a>
26a	TRANSFORMER, 480V	<a href="#">137694</a>

Key	Description	Part No.
27	WATER LEVEL BOARD	<a href="#">122192</a>
28	CONNECTOR	<a href="#">140416</a>
29	CLASSIC CONTROL	<a href="#">174843</a>
30A	ADVANCED CONTROL	<a href="#">174837</a>
30B	C2T CONTROL	<a href="#">176895</a>
31	RTD PROBE(NOT SHOWN)	<a href="#">175429</a>
32	PRESSURE SWITCH	177794
33	ELECTRODE WATER LEVEL	015589
34	ELEMENT - 20/24 208/240V	001706
34a	ELEMENT - 20/24 480V	010996
34b	ELEMENT - 40/48 208/240V	011094
34c	ELEMENT - 40/48 480V	011088
x	CRANK TILT MECHANISM ASSEMBLY	-
35	GEAR CARRIER ASSEMBLY	<a href="#">124741</a>
36	HANDWHEEL SHAFT	<a href="#">122374</a>
37	WORM GEAR	<a href="#">128001</a>
38	HANDWHEEL ASSEMBLY	<a href="#">124719</a>
39	KEY, 1/4 SG X 1"	<a href="#">122371</a>
40	BEARING BACK ASSEMBLY	<a href="#">128021</a>
41	ROLL PIN .25 X 1.25	012614
42	ROLL PIN .25 X 1.625	<a href="#">128036</a>
43	PLUG PIPE	010286
44	FITTING, GREASE 90	012195
45	BRASS FITTING, 1/8 NPT	175231
46	WASHER, SPLIT LOCK 3/8	005618
47	SCREW, 3/8-16 X 1 HEX HEAD	005612
48	WASHER, FLAT 3/8	005830
49	GEAR SECTOR ASSEMBLY	<a href="#">128028</a>
50	BEARING ROLLER	002790
51	RETAINING RING, 1.5"	<a href="#">124764</a>
52	COVER ELEMENT HOUSING	003141
53	STATION COVER	175237
54	DECAL OPERATING INSTRUCTIONS - CLASSIC CTRL	<a href="#">175298</a>
55	DECAL OPERATING INSTRUCTIONS - ADVANCED CTRL	<a href="#">175610</a>
x	HARNES, HIGH VOLTAGE	<a href="#">149945</a>
x	HARNES, CONTROL, TDB	175289
x	HARNES, ELEMENT	<a href="#">148718</a>
x	FERRITE BEAD (NOT SHOWN)	<a href="#">175836</a>
x	OVERLAY, C2T	176892
x	CORE PROBE, TDB-20 & 24, C2T	176677
x	CORE PROBE, TDB-40 & 48, C2T	176678
x	BRACKET, CORE PROBE, TDB-20 & 24, C2T	176658
x	BRACKET, CORE PROBE, TDB-40 & 48, C2T	176659
x	BRACKET ASSEMBLY, CORE PROBE STORAGE	177091
x	SOCKET, PANEL MOUNT ASSY, CORE PROBE, C2T	176925
x	CAP, SOCKET, PANEL MOUNT, CORE PROBE, C2T	176927
x	WIRE HARNES, CONTROL, CORE PROBE, C2T	176920
x	HARNES, CONTROL, TDB, C2T	177262

x- Item not depicted/called out in drawing or photograph

# Wiring Diagram

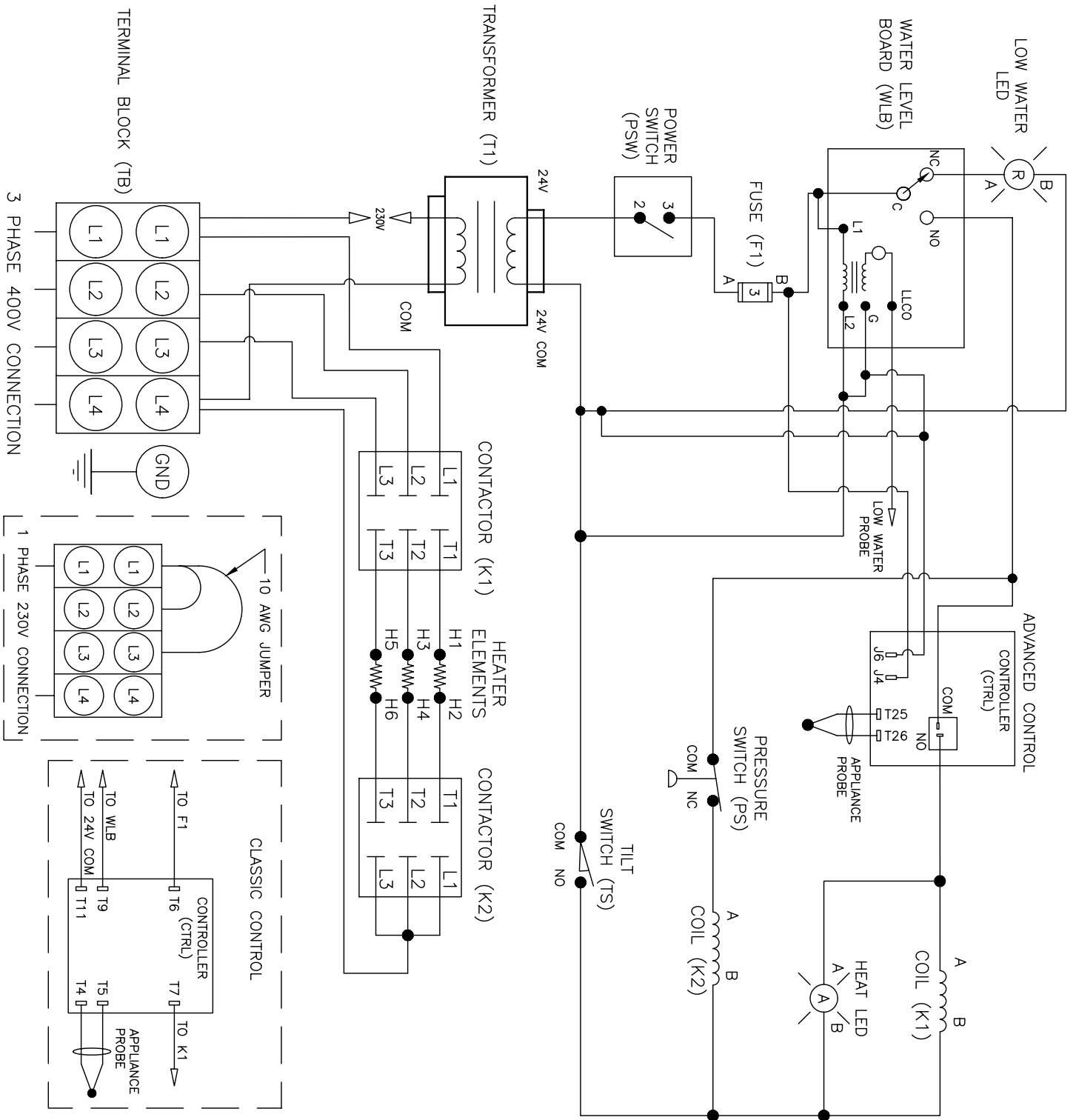

TDB & DEE (CE) CLASSIC/ADVANCED P/N 177796 REV. B

