



OPERATOR MANUAL

IMPORTANT INFORMATION, KEEP FOR OPERATOR

888-994-7636, fax 888-864-7636
unifiedbrands.net

THIS MANUAL MUST BE RETAINED FOR FUTURE REFERENCE. READ, UNDERSTAND AND FOLLOW THE INSTRUCTIONS AND WARNINGS CONTAINED IN THIS MANUAL.

FOR YOUR SAFETY Instructions to be followed in the event user smells gas. This information shall be obtained by consulting your local gas supplier. As a minimum, turn off the gas and call your gas company and your authorized service agent. Evacuate all personnel from the area.

WARNING Improper installation, adjustment, alteration, service or maintenance can cause property damage, injury or death. Read the installation, operating and maintenance instructions thoroughly before installing or servicing this equipment.

NOTIFY CARRIER OF DAMAGE AT ONCE It is the responsibility of the consignee to inspect the container upon receipt of same and to determine the possibility of any damage, including concealed damage. Groen suggests that if you are suspicious of damage to make a notation on the delivery receipt. It will be the responsibility of the consignee to file a claim with the carrier. We recommend that you do so at once.

Manufacture Service/Questions 888-994-7636.

This manual provides information for:

STEAM JACKETED KETTLE MODELS TDH(C)-20/24/40/48 (C,A) (CE) INTER- NATIONAL

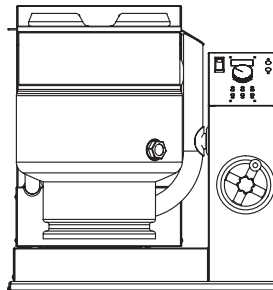

REFERENCES

CSA INTERNATIONAL
8501 East Pleasant Valley Road
Cleveland, Ohio 44131

NSF INTERNATIONAL
798 N. Dixboro Rd.
P.O. Box 130140
Ann Arbor, Michigan 48113-0140

UNDERWRITERS LABORATORIES, INC.
333 Pflugsten Road
Northbrook, Illinois 60062

KLENZADE SALES CENTER ECOLAB, Inc.
370 Wabasha
St. Paul, Minnesota 55102

NATIONAL FIRE PROTECTION ASSOCIATION
60 Battery March Park
Quincy, Massachusetts 02269

NFPA/54 - Installation Gas Appliances & Piping
NFPA/70 - The National Electric Code

ZEP MANUFACTURING COMPANY
1310-T Seaboard Industrial Boulevard
Atlanta, Georgia 30318

EQUIPMENT DESCRIPTION

TDH and TDHC models are stainless steel, steam-jacketed, table top mounted kettles with a self-contained, gas heated steam source. The TDHC has a crank tilt hand wheel, and the TDH has a handle that allows the operator to manually tilt the kettle. The kettle body is welded into one solid piece and furnished with a reinforced rim and welded-in "butterfly" shaped pouring lip. The interior of the kettle is polished to a 180 emery grit finish, and the exterior is given a bright high buff finish. This has a steam jacket rated for working pressures up to 50 PSI (345k, 3.45 bars).

The self-contained steam source is heated by propane or natural gas and is equipped with electronic ignition. Charged at the factory with chemically pure water containing rust inhibitors, the steam source provides kettle temperatures of 150°F (65°C) to approximately 295°F (146°C).

Controls for the TDHC unit include a crank tilt handwheel, thermostat, pressure gauge, pressure relief valve, low water cut-off, On/Off switch, indicator lamp, gas regulator valve, and water level sight glass. Controls for the TDH are the same as the above, with the exception of the crank tilt hand wheel.

The gas supply shuts off automatically when the kettle is tilted.

The unit must be specified for use with natural gas (G20) or propane (G31). For other gas types, consult factory. Service connections are required for gas and 115V electricity.

Options available include:

1. One-piece, Lift-off cover
2. Holder for Lift-off Cover
3. Basket insert
4. Rice Strainer
5. Stand that supports the unit and holds a pan in position for filling
6. Water fill swing faucet
7. 316 stainless steel interior (must be indicated on initial order)



Information contained in this document is known to be current and accurate at the time of printing/creation. Reference our product line website for the most updated product information and specifications. © 2023 Electrolux Professional, Inc. All Rights Reserved.

IMPORTANT - READ FIRST - IMPORTANT

IMPORTANT: THESE APPLIANCES MUST BE INSTALLED BY A COMPETENT PERSON IN CONFORMITY WITH THE INSTALLATION AND SERVICING INSTRUCTIONS AND NATIONAL REGULATIONS IN FORCE AT THE TIME. PARTICULAR ATTENTION MUST BE PAID TO THE FOLLOWING (CE):

I. E. E. REGULATIONS FOR ELECTRICAL INSTALLATIONS

ELECTRICITY AT WORK REGULATIONS

GAS SAFETY (INSTALLATION & USE REGULATIONS

HEALTH AND SAFETY AT WORK ACT

FIRE PRECAUTIONS ACT

LOCAL AND NATIONAL BUILDING REGULATIONS

DETAILED RECOMMENDATIONS ARE CONTAINED IN INSTITUTE OF GAS ENGINEERS PUBLISHED DOCUMENTS: IGE/UP/1, IGE/UP/2, BS6173 AND BS5440 (CE).

THESE APPLIANCES HAVE BEEN CE-MARKED ON THE BASIS OF COMPLIANCE WITH THE GAS APPLIANCE DIRECTIVE, EMC AND LOW VOLTAGE DIRECTIVE FOR THE COUNTRIES, GAS TYPES AND PRESSURES AS STATED ON THE DATA PLATE.

WARNING: FAILURE TO DISCONNECT POWER BEFORE SERVICING COULD RESULT IN ELECTROCUTION AND DEATH.

WARNING: IMPROPER INSTALLATION, ADJUSTMENT, ALTERATION, SERVICE OR MAINTENANCE CAN CAUSE PROPERTY DAMAGE, INJURY OR DEATH. READ THE INSTALLATION, OPERATING AND MAINTENANCE INSTRUCTIONS THOROUGHLY BEFORE INSTALLING OR SERVICING THIS EQUIPMENT.

WARNING: THE UNIT MUST BE INSTALLED BY PERSONNEL QUALIFIED TO WORK WITH GAS, ELECTRICITY AND PLUMBING. UNIT MUST BE INSTALLED IN ACCORDANCE WITH ALL APPLICABLE CODES.

WARNING: DO NOT ATTACH THE UNIT TO A TYPE "B" VENT. IT COULD CAUSE FIRE OR PROPERTY DAMAGE.

WARNING: DO NOT CONNECT ANY PIPING TO THE PRESSURE RELIEF VALVE. IT MUST BE FREE TO VENT STEAM AS NEEDED. TO AVOID BURNS FROM THE VENTED STEAM THE VALVE DISCHARGE SHOULD POINT DOWNWARD.

DANGER: ELECTRICALLY GROUND THE UNIT AT THE TERMINAL PROVIDED. FAILURE TO GROUND THE UNIT COULD RESULT IN ELECTROCUTION AND DEATH.

CAUTION: BE SURE ALL OPERATORS READ, UNDERSTAND AND FOLLOW THE OPERATING INSTRUCTIONS, CAUTIONS AND SAFETY INSTRUCTIONS CONTAINED IN THIS MANUAL.

CAUTION: DO NOT OVERFILL THE KETTLE WHEN COOKING, HOLDING OR CLEANING. KEEP LIQUIDS A MINIMUM OF 2-3" (5-8 CM) BELOW THE KETTLE BODY RIM TO ALLOW CLEARANCE FOR STIRRING, BOILING AND SAFE TRANSFER OF PRODUCT.

CAUTION: KEEP FLOORS IN FRONT OF KETTLE WORK AREA CLEAN AND DRY. IF SPILLS OCCUR, CLEAN IMMEDIATELY TO AVOID SLIPS OR FALLS.

WARNING: KEEP WATER AND SOLUTIONS OUT OF CONTROLS AND BURNERS. NEVER USE A HIGH PRESSURE HOSE TO CLEAN KETTLE SURFACES.

CAUTION: MOST CLEANERS ARE HARMFUL TO THE SKIN, EYES, MUCOUS MEMBRANES AND CLOTHING. TAKE PRECAUTIONS: WEAR RUBBER GLOVES, GOGGLES OR FACE SHIELD AND PROTECTIVE CLOTHING. CAREFULLY READ WARNINGS AND FOLLOW DIRECTIONS ON CLEANER LABELS.

WARNING: DO NOT STAND ON OR APPLY UNNECESSARY WEIGHT OR PRESSURE ON THE KETTLE FRONT OR POURING LIP. THIS COULD RESULT IN THE OVERLOAD AND FAILURE OF THE TILT MECHANISM, AND POSSIBLE SERIOUS INJURY AND BURNS TO THE OPERATOR AND OTHERS.

NOTICE: NEVER LEAVE A SANITIZER IN CONTACT WITH STAINLESS STEEL SURFACES LONGER THAN 30 MINUTES. LONGER CONTACT CAN CAUSE CORROSION.

WARNING: FAILURE TO PERIODICALLY CHECK PRESSURE RELIEF VALVE OPERATION COULD RESULT IN PERSONAL INJURY AND/OR DAMAGE TO EQUIPMENT.

WARNING: WHEN TESTING, AVOID EXPOSURE TO THE STEAM BLOWING OUT OF THE PRESSURE RELIEF VALVE. DIRECT CONTACT COULD RESULT IN SEVERE BURNS.

WARNING: TO AVOID INJURY, READ AND FOLLOW ALL PRECAUTIONS STATED ON THE LABEL OF THE WATER TREATMENT COMPOUND.

WARNING: BEFORE REPLACING ANY PARTS, DISCONNECT THE UNIT FROM THE ELECTRIC POWER SUPPLY AND CLOSE THE MAIN GAS VALVE. ALLOW FIVE MINUTES FOR GAS TO VENT.

CAUTION: USE OF ANY REPLACEMENT PARTS OTHER THAN THOSE SUPPLIED BY THE MANUFACTURER OR AUTHORIZED DISTRIBUTORS CAN CAUSE INJURY TO THE OPERATOR AND DAMAGE TO THE EQUIPMENT AND WILL VOID ALL WARRANTIES.

WARNING: KEEP AREA AROUND KETTLE FREE AND CLEAR OF ALL COMBUSTIBLE MATERIALS. FAILURE TO DO SO COULD RESULT IN FIRE OR PROPERTY DAMAGE.

CAUTION: HEATING AN EMPTY KETTLE MAY CAUSE THE RELEASE OF STEAM FROM THE PRESSURE RELIEF VALVE.

IMPORTANT: SERVICE PERFORMED BY OTHER THAN FACTORY AUTHORIZED PERSONNEL WILL VOID ALL WARRANTIES.

NOTICE: IT IS RECOMMENDED THAT AN INSTANT-READ THERMOMETER BE USED TO CHECK THE INTERNAL TEMPERATURE THROUGHOUT THE COOKING PROCESS AND AFTER THE COOKING PROCESS HAS BEEN COMPLETED TO ENSURE THE FOOD HAS BEEN COOKED SUFFICIENTLY.

CAUTION: THIS APPLIANCE CAN BE USED BY CHILDREN AGED FROM 8 YEARS AND ABOVE AND PERSONS WITH REDUCED PHYSICAL, SENSORY OR MENTAL CAPABILITIES OR LACK OF EXPERIENCE AND KNOWLEDGE IF THEY HAVE BEEN GIVEN SUPERVISION OR INSTRUCTION CONCERNING USE OF THE APPLIANCE IN A SAFE WAY AND UNDERSTAND THE HAZARDS INVOLVED.

CAUTION: CHILDREN SUPERVISED ARE NOT TO PLAY WITH THIS APPLIANCE.

CAUTION: CLEANING AND USER MAINTENANCE SHALL NOT BE MADE BY CHILDREN WITHOUT SUPERVISION.

CAUTION: FOR APPLIANCES INTENDED FOR USE AT ALTITUDES EXCEEDING 2,000 M, THE MAXIMUM ALTITUDE WILL BE STATED OR MARKED ON APPLIANCE.

PERFORMANCE DATA

Model	Firing Rate, BTU/hr
TDH-20, TDHC-20, TDH-24, TDHC-24	28,000
TDH-40, TDHC-40, TDH-48, TDHC-48	48,800

Model	Firing Rate, BTU/hr
TDH-20, TDHC-20, TDH-24, TDHC-24	28,000
TDH-40, TDHC-40, TDH-48, TDHC-48	48,800

Injector Diameters	TDH-20	TDH-40
G20 Nat. Gas	0.94 mm	1.09 mm
No. of Orifices	8	12
G25 Nat. Gas	1.09 mm	1.19 mm
No. of Orifices	8	12
G31 Nat. Gas	0.57 mm	0.66 mm
No. of Orifices	8	12

Model	Kettle Capacity	Jacket Capacity	Kettle Body Diameter	Kettle Body Depth	Base Width	Base Depth
TDH-20 (C,A) TDHC-20 (C,A)	5 Gal. (20 Qt.)	6 Qt	14 inches	11 inches	28 inches	24 inches
	19 liter	5.7 liter	356 mm	279 mm	711 mm	610 mm
TDH-24 (C,A) TDHC-24 (C,A)	6-Gal. (24 Qt.)	6 Qt	14 inches	12-1/2 inches	28 inches	24 inches
	23 liter	5.7 liter	356 mm	318 mm	711 mm	610 mm
TDH-40 (C,A) TDHC-40 (C,A)	10 Gal. (40 Qt.)	12 Qt	16-1/2 inches	14-1/2 inches	28 inches	26-3/4 inches
	38 liter	11.4 liter	419 mm	368 mm	711 mm	680 mm
TDH-48 (C,A) TDHC-48 (C,A)	12 Gal. (48 Qt.)	12 Qt	16-1/2 inches	16 inches	28 inches	26-3/4 inches
	45 liter	11.4 liter	419 mm	406 mm	711 mm	680 mm

Gas Pressure Adjustment		TDH-20	TDH-40
G20, G25 Natural Gas	mbar	8.75	8.75
	in w.c.	3.5	3.5
G31 Propane Gas	mbar	25	25
	in w.c.	10	10

INSPECTION & UNPACKING

CAUTION: SHIPPING STRAPS ARE UNDER TENSION AND CAN SNAP BACK WHEN CUT. TAKE CARE TO AVOID PERSONAL INJURY OR DAMAGE TO THE UNIT BY STAPLES LEFT IN THE WALLS OF THE CARTON.

CAUTION: THIS UNIT WEIGHS BETWEEN 214 AND 240 POUNDS (98 TO 109 KG) DEPENDING ON SIZE. INSTALLER SHOULD USE PROPER EQUIPMENT TO LIFT SAFELY.

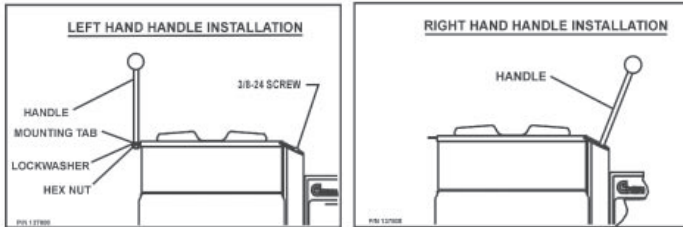

Figure 1



Figure 2

The unit arrives completely assembled, except for the tilting handle on hand tilt models which is shipped inside the kettle. The unit is strapped on a skid and in a heavy carton. Inspect the carton carefully for damage. Open the container and check the unit for hidden damage. Report shipping damage or shipment errors to the delivery agent.

Write down the model number, serial number, and installation date for your unit at the top of the Service Log at the end of this manual. Keep this manual with the unit.

To remove the kettle from the box, cut any straps from around the box. Detach the box sides from the skid. Pull the box up off the unit, taking care to avoid damage or injury from any staples left in the box walls. When installation is to begin, cut the straps holding the kettle on the skid, and lift the kettle straight up off the skid. Examine the packing materials to make sure no loose parts are discarded with the materials. On hand tilt models, the tilting handle may be screwed into its socket. Attach handle to the kettle on left side or right side as shown below.

INSTALLATION

WARNING: THE UNIT MUST BE INSTALLED BY PERSONNEL WHO ARE QUALIFIED TO WORK WITH GAS, ELECTRICITY AND PLUMBING. IMPROPER INSTALLATION CAN CAUSE INJURY TO PERSONNEL AND/OR DAMAGE TO THE EQUIPMENT. THE UNIT MUST BE INSTALLED IN ACCORDANCE WITH APPLICABLE CODES. THE UNIT MUST BE INSTALLED BY A LICENSED PLUMBER OR GAS FITTER WHEN INSTALLED WITHIN THE COMMONWEALTH OF MASSACHUSETTS.

DANGER: ELECTRICALLY GROUND THE UNIT AT THE TERMINAL PROVIDED. FAILURE TO GROUND UNIT COULD RESULT IN ELECTROCUTION AND DEATH.

WARNING: THIS UNIT IS FOR COMMERCIAL USE. DO NOT USE HOME OR RESIDENTIAL GRADE GAS CONNECTIONS. THEY DO NOT MEET GAS CODES AND COULD BE HAZARDOUS.

For efficient performance the kettle must be installed in a well-ventilated area. Items which might restrict or obstruct the flow of air for combustion and ventilation must be removed. The area directly around the appliance must be free of combustible materials.

1. Installation can be on a combustible or noncombustible floor. Clearances should be per table below.

	MINIMUM CLEARANCE FROM COMBUSTIBLE WALLS	RECOMMENDED CLEARANCES
Left Side	1 in. (25 mm)	1 in. (25 mm)
Right Side	0 in. (0 mm)	12-16 in. (305-406 mm) for servicing
Rear	1 in. (25 mm)	3 in. (76 mm) for faucet bracket

2. We recommends installation of the unit under a vent hood. The base must be fastened to a working surface or stand.
3. Complete the piping to the gas service main using ½ inch IPS (1/2" BSPT) pipe or an approved equivalent.
4. Provide 230 VAC, 50 Hz, 1 Phase, 1 Amp or 40W electric service. The wiring must be executed in accordance with regulations IEE Regulation For Electrical Installations and Electricity at Work Regulations. AN ELECTRICAL GROUND IS REQUIRED. Equipotential (Figure 2) and protective (Figure 1) earth ground terminals are provided. The electrical schematic is located on the inside of the service panel and in this manual.
5. Electrical connection to the unit must be water resistant sealtite conduit type or equal and utilize the water resistant conduit fitting provided on the unit.
6. The installation must conform with local codes or in accordance to recommendations are contained in the Institute of Gas Engineers publications IGE/UP/1, IGE/UP/2, BS6173 & BS5440. The kettle should be installed in an adequately ventilated room with provision for adequate air supply. The best ventilation will employ a vent hood and exhaust fan with no direct connection between the vent duct and the kettle flue. DO NOT obstruct the flue or vent duct after installation.
7. PRESSURE TEST WARNING
 - a. Test pressure exceeding ½ PSIG (3.45 kPa). During pressure testing of the gas supply piping system at pressures exceeding ½ PSIG (3.45), the appliance and its individual shutoff valve must be disconnected from the gas supply piping system.
 - b. Test pressure equal to or less than ½ PSIG (3.45 kPa). During pressure testing of the gas supply piping system at pressures equal to or less than ½ PSIG, the kettle must be isolated from the gas supply piping system by closing its individual manual shutoff valve.
8. Adequate space for proper servicing and operation is required. DO NOT block any air intake spacings to the combustion chamber or obstruct air flow.
9. After the kettle has been connected to the gas supply, check all gas joints for leaks. A soap solution or other suitable gas leak detector should be used. Do not use flame when checking for leaks.
10. Once the unit is anchored to a mounting surface, apply a small bead of silicone caulk around the perimeter of the kettle base and seal the joint.
11. Make sure the water level is correct in the jacket, by confirming that the level is near the middle of the sight glass. If the water level is low, follow the instructions in Jacket Filling and Water Treatment in the Maintenance section of this manual.
12. Check to be sure that the open end of the elbow on the outlet of the pressure relief valve is directed downward. Be sure to read and follow the instructions on the attached pressure relief valve tag.

INITIAL START-UP

IMPORTANT: BE SURE ALL OPERATORS READ, UNDERSTAND AND FOLLOW THE OPERATING INSTRUCTIONS, CAUTIONS, AND SAFETY INSTRUCTIONS CONTAINED IN THIS MANUAL.

WARNING: DO NOT STAND ON OR APPLY UNNECESSARY WEIGHT OR PRESSURE ON THE KETTLE FRONT OR POURING LIP. THIS COULD RESULT IN THE OVERLOAD AND FAILURE OF THE TILT MECHANISM, AND POSSIBLE SERIOUS INJURY AND BURNS TO THE OPERATOR AND OTHERS.

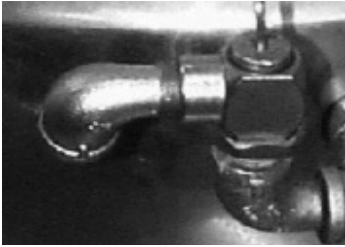

The open end of the pressure relief valve elbow must face downward.

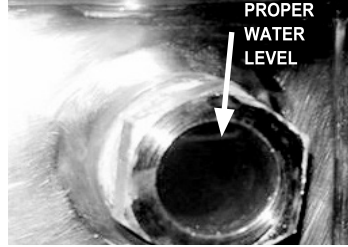

Correct water level.

After the kettle has been installed, the installer should test to ensure that it is operating correctly.

1. Remove literature and packing materials from inside and outside of the unit.
2. Add water to the kettle to a depth of at least one inch.
3. Make sure the supplies of gas and electric power are on.
4. Follow the “To Start Kettle Heating” instructions in the Operation section of this manual. Begin heating the water at the highest thermostat setting. The indicator light should come on and heating should continue until the water boils.
5. To turn off the unit, follow “To Stop Kettle Heating” in the Operation Section of this manual.

If the kettle functions as described, it is ready for use. If the unit does not operate as designed, contact an authorized Service Agent.

OPERATION

WARNING: WHEN TILTING KETTLE:

- 1) WEAR PROTECTIVE OVEN MITT AND PROTECTIVE APRON.
- 2) USE DEEP CONTAINER TO CONTAIN AND MINIMIZE PRODUCT SPLASHING.
- 3) PLACE CONTAINER ON STABLE, FLAT SURFACE, AS CLOSE TO KETTLE AS POSSIBLE.
- 4) STAND TO RIGHT OF KETTLE WHILE POURING — NOT DIRECTLY IN POUR PATH OF HOT CONTENTS.
- 5) POUR SLOWLY, MAINTAINING CONTROL OF KETTLE, AND RETURN KETTLE BODY TO UPRIGHT POSITION AFTER CONTAINER IS FILLED OR TRANSFER IS COMPLETE.
- 6) DO NOT OVERFILL CONTAINER. AVOID SKIN CONTACT WITH HOT CONTAINER AND ITS CONTENTS.

WARNING: AVOID ALL DIRECT CONTACT WITH HOT SURFACES AND HOT FOOD OR WATER IN THE KETTLE. DIRECT CONTACT COULD RESULT IN SEVERE BURNS.

CAUTION: DO NOT OVERFILL THE KETTLE WHEN COOKING, HOLDING OR CLEANING. KEEP LIQUIDS AT LEAST 2-3” (5-8 CM) BELOW THE KETTLE RIM TO ALLOW CLEARANCE FOR STIRRING, BOILING AND SAFE PRODUCT TRANSFER.

WARNING: AVOID ALL DIRECT CONTACT WITH HOT FOOD OR WATER IN THE KETTLE. DIRECT CONTACT COULD RESULT IN SEVERE BURNS.

CAUTION: HEATING AN EMPTY KETTLE MAY CAUSE THE RELEASE OF STEAM FROM THE PRESSURE RELIEF VALVE.

CAUTION: DO NOT TILT KETTLE BODY WITH COVER OR BASKET INSERT IN PLACE. COVER MAY SLIDE OFF, CAUSING INJURY TO OPERATOR.

CAUTION: ANY POTENTIAL USER OF THE EQUIPMENT MUST BE TRAINED IN SAFE AND CORRECT OPERATING PROCEDURES.

WARNING: KEEP AREA AROUND KETTLE FREE AND CLEAR OF ALL COMBUSTIBLE MATERIALS. DO NOT ATTEMPT TO LIGHT ANY BURNER WITH A FLAME.



Classic Control



Advanced Control

CONTROLS

1. Classic Control (-C) Models

- a. The manual gas shut-off valve supplies inlet gas to the unit.
- b. Lighted Power ON switch located on the control console. Controls main power to the unit.
- c. The temperature knob, located on the control console, is used to set the kettle heat values between 1 and 10.
- d. Heating indicator light located on the control console, lights when the controller sends call to open the main gas valve and will cycle on and off once the unit reaches set temperature. If the unit is tilted, the main gas valve will be disabled and the light will turn off until the unit is returned to the cooking position.
- e. A LOW WATER indicator light, located on the control console, illuminates when the jacket water falls below acceptable levels. When lit, the main gas valve is disabled and will not function until the jacket water is refilled using the procedure in this manual.
- f. On Crank tilt (TDHC) units, a handwheel controls the worm and gear mechanism that smoothly tilts the kettle body and holds it in the desired position.

2. Advanced Control (-A) Models

- a. The manual gas shut-off valve supplies inlet gas to the unit.
- b. Lighted Power ON switch located on the control console. Controls main power to the unit.
- c. The temperature knob, located on the control console, is used to set the kettle heat values between 1.0 and 10.0. The current setting will be reflected on the display.
- d. Heating indicator light located on the control console, lights when the controller sends call to open the main gas valve and will cycle on and off once the unit reaches set temperature. If the unit is tilted, the main gas valve will be disabled and the light will turn off until the unit is returned to the cooking position.
- e. A LOW WATER indicator light, located on the control console, illuminates when the jacket water falls below acceptable levels. When lit, the main gas valve is disabled and will not function until the jacket water is refilled

using the procedure in this manual.

- f. SET TnnP Mode - Allows power to the controller and gas to the pilot without the kettle heating; the kettle will heat once the LOW TEMP, MANUAL or HIGH TEMP button is selected.
- g. LOW TEMP Button – Used to set operating temperature of the kettle at a preset low intensity (default = 2.0). Can be pressed at any time during operation of the unit to change the set temperature to the preset value except when there is an active TIMER enabled.
- h. MANUAL Mode button – Enables the user modify the desired cooking temperature of the kettle (between 1.0 and 10.0) using the temperature knob and display (default = 5.0). The operator will press the MANUAL button and set the desired temperature using the temperature knob and display. Once the desired intensity is displayed, the user may either press the MANUAL button again or wait 5 seconds and the set temperature will be accepted by the controller and locked in. After the set temperature is accepted, it may be changed at any time by pressing the MANUAL button and resetting the temperature using the same process above.
- i. HIGH TEMP button – Used to set operating temperature of the kettle at a preset high intensity (default = 7.0). Can be pressed at any time during operation of the unit to change the set temperature to the preset value except when there is an active TIMER enabled.
 1. TIMER button - once the appropriate set temperature is selected using the HIGH TEMP, MANUAL or LOW TEMP buttons; a countdown timer can be set to remind the user when the cooking process is completed. Range – 1 minute to 10 hours
 2. When the timer expires:
 - a. the set temperature will automatically change to the LOW TEMP setting and will continue at this setting until the user changes the temperature via MANUAL or HIGH TEMP buttons
 - b. An audible alarm will notify the user that attention is required, the alarm will continue to sound until the user presses the TIMER button.
 3. An active timer can be cancelled by pressing and holding the TIMER button for 5 secs.
 4. Set temp can be changed during an active timer by pressing the MANUAL button and adjusting the set temp using the Temperature knob and display.
 5. HIGH TEMP and LOW TEMP presets cannot be used to change the setpoint once a TIMER has started.
- j. READY alarm – The control will sound 3 beeps when the unit has reached within 20 degrees of set point during pre-heat and when a higher set temperature is selected.
- k. On Crank tilt (TDHC) units, a handwheel controls the worm and gear mechanism that smoothly tilts the kettle body and holds it in the desired position.

OPERATING PROCEDURE

1. To Start Kettle Heating:
 - a. EVERY DAY make sure that the jacket water level in the middle of the sight glass. If the level is too low, see “Jacket Filling and Water Treatment” in this manual.
 - b. Check the pressure/vacuum gauge. If the gauge does not show 20 to 30 inches of mercury (Hg) vacuum (that is a reading of 20 to 30 below 0 atmospheric pressure), see “Jacket Vacuum” in this manual.
 - c. DO NOT attempt to light any burner with a flame.
 - d. Open the main supply gas valve (handle in line with the pipe).
 - e. Turn the switch to ON.
 - f. Set heat using instructions above.

2. To Stop Kettle Heating:
 - a. Turn the switch OFF.
 - b. Turn the manual gas valve OFF (handle a right angle to gas line).
 - c. Disconnect the units electrical power.
3. To Relight Kettle:
 - a. Close main gas supply valve.
 - b. Set on-off switch to OFF.
 - c. Wait five minutes, then proceed as directed under To Start Kettle Heating.
4. If electric power fails, do not attempt to operate the unit. When power is restored, proceed as directed in To Start Kettle Heating.
5. To Transfer Product or Empty Kettle:
 - a. Crank Tilt Kettles: The kettle body is tilted using the crank tilt handwheel. Turning the crank counter-clockwise tilts the kettle body; clockwise returns it to an upright position. The kettle body will remain in any tilted position.
 - b. Hand Tilt Kettles: The kettle is designed to be tilted in a controlled manner. Grasp the insulated plastic ball firmly. Maintain a firm grip on the handle when tilting, keeping the kettle body in a tilted position or SLOWLY returning the kettle body to an upright position.

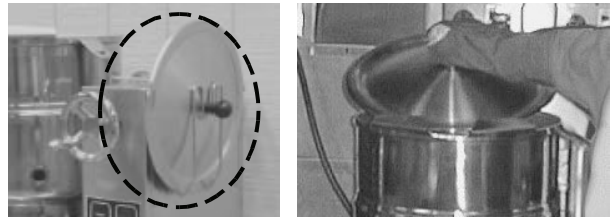

Lift the rear of the lid first.

USE OF COMMON ACCESSORIES

1. Lift-Off Cover:
 - a. As with stock pot cooking, an optional lift off cover will speed up the heating of water and food products. A cover helps retain heat in the cooking vessel and reduces the amount of heat and humidity released into the kitchen. Use of a cover can reduce some product cook times and help maintain the temperature, color and texture of products being held or simmered for extended periods.
 - b. Make sure the plastic ball handle is secure on the lift off cover before using. ALWAYS use the plastic handle to place or remove cover from the kettle. Wear protective oven mitts and a protective apron.
 - c. When putting the cover on the kettle, position it on top of kettle rim, with its flat edge facing the pouring lip.
 - d. When removing cover:
 - 1) Firmly grasp plastic handle
 - 2) Lift rear edge (farthest from operator) 1-2” (3-5 cm) to allow any steam and water vapor to escape the cooking vessel. Wait 2-3 seconds.
 - 3) Tilt cover to 45-60° angle and allow any hot condensate or product to roll off cover back into kettle.
 - 4) Remove cover, ensuring that any remaining hot condensate or product does not drip on operator, floor or work surfaces.
 - 5) Place cover on safe, flat, sanitary, out-of-the-way surface, or return to kettle rim. Cover may also be placed in the optional holder for cover as shown in the photograph.
2. Basket Insert:
 - a. An optional kettle basket insert can assist in cooking water-boiled

products including eggs, potatoes, vegetables, shell fish, pasta and rice. The nylon mesh liner must be used when cooking product smaller than the mesh size of the basket, which is approximately 1/4" (6 mm). This includes rice and small pasta shapes.

b. Tips For Use:

- 1) Allow for the water displacement of the basket and product to be cooked. This may mean only filling the kettle half full of water. Test the basket and product displacement with the kettle OFF, and with cold water in the kettle.
- 2) Load basket on a level, stable work surface.
- 3) Lift the loaded basket with both hands. Get help from another person if the basket is too heavy for safe handling. Then slowly lower product into kettle.
- 4) When removing basket with cooked product, lift basket straight up, ensuring bottom of basket clears the rim and pouring lip of the kettle. Wear protective oven mitts and protective apron.
- 5) Allow hot water to fully drain from product, before moving basket away from the kettle. Do not rest kettle basket on kettle rim or pouring lip. If basket is too heavy for individual to lift and safely move, get help from another person. Remove product immediately from basket into another container, being sure to avoid contact with hot product and hot basket or place basket with food on stable, flat surface, setting it inside a solid steamer or bake pan, to catch any remaining hot water draining from product.

PRECAUTIONS

Before cleaning, shut off the kettle by turning the main power switch to "OFF," and shut off all electric power to the unit at a remote switch, such as the circuit breaker.

PROCEDURE

1. Clean food-contact surfaces as soon as possible after use. If the unit is in continuous use, thoroughly clean and sanitize the interior and exterior at least once every 12 hours.
2. Scrape and flush out food residues. Be careful not to scratch the kettle with metal implements. (For DHT models only: After flushing the kettle, close the draw-off valve.)
3. Prepare a hot solution of the detergent/ cleaning compound as instructed by the supplier. Clean the unit thoroughly. A cloth moistened with cleaning solution can be used to clean controls, housings, and electrical conduits.
4. Rinse the kettle and draw-off valve parts thoroughly with hot water, then drain completely.
5. As part of the daily cleaning program, clean soiled external and internal surfaces. Remember to check the sides of the unit and control housing, underside of cover, etc.
6. To remove burnt on foods, use a brush, sponge, cloth, plastic or rubber scraper, or plastic wool with the cleaning solution. To reduce effort required in washing, let the detergent solution sit in the kettle and soak into the residue. Do NOT use abrasive materials or metal tools that might scratch the surface. Scratches make the surface harder to clean and provide places for bacteria to grow. Do NOT use steel wool, which may leave particles in the surface and cause eventual corrosion and pitting.
7. The outside of the unit may be cleaned with a warm water (100°F or less) spray. Do not use a high pressure spray.
8. The outside of the unit may be polished with a stainless steel cleaner such as "Zepper" from Zep Manufacturing Co.
9. When equipment needs to be sanitized, use a solution equivalent to one that supplies 200 parts per million available chlorine. Obtain advice on sanitizing agents from your supplier of sanitizing products.
10. It is recommended that each piece of equipment be sanitized just before use.
11. Clean the kettle thoroughly. If there is difficulty removing mineral deposits or a film left by hard water or food residues, then use a de-liming agent, following manufacturer directions.
12. Rinse and drain the unit thoroughly before further use.
13. If cleaning problems persist, contact your cleaning product representative for assistance. The supplier has a trained technical staff with laboratory facilities to serve you.

CLEANING

WARNING: KEEP WATER AND SOLUTIONS AWAY FROM CONTROLS AND ELECTRICAL EQUIPMENT. NEVER SPRAY THE SUPPORT HOUSING OR ELECTRICAL CONNECTIONS.

CAUTION: MOST CLEANERS ARE HARMFUL TO THE SKIN, EYES, MUCOUS MEMBRANES, AND CLOTHING. PRECAUTIONS SHOULD BE TAKEN. WEAR RUBBER GLOVES, GOGGLES OR FACE SHIELD, AND PROTECTIVE CLOTHING. READ THE WARNINGS AND FOLLOW THE DIRECTIONS ON THE LABEL OF THE CLEANER CAREFULLY.

CAUTION: NEVER LEAVE A SANITIZER IN CONTACT WITH STAINLESS STEEL SURFACES LONGER THAN 30 MINUTES. LONGER CONTACT CAN CAUSE CORROSION.

WARNING: AVOID DIRECT CONTACT WITH HOT SURFACES. DIRECT SKIN CONTACT COULD RESULT IN SEVERE BURNS.



Use a brush, sponge, cloth, plastic or rubber scraper, or plastic wool to clean.



Don't use metal implements or steel wool when cleaning.



CLEANING CORE PROBE

Remove all food soil from core probe by wiping entire core probe and cable assembly with warm detergent solution and a clean cloth. Remove detergent solution by wiping core probe and cable assembly with clean rinse water and a cloth. Allow core probe and cable assembly to air dry. Do not immerse core probe. Hand wash only and immediately let air dry.

SUGGESTED CLEANING SUPPLIES

1. Cleaner, such as Klenzade HC-10 or HC-32 from ECOLAB, Inc. or equivalent.
2. Kettle brushes in good condition
3. Sanitizer such as Klenzade XY-12.
4. Film remover such as Klenzade LC-30.

MAINTENANCE

WARNING: AVOID ANY EXPOSURE TO THE STEAM BLOWING OUT OF THE PRESSURE RELIEF VALVE. SEVERE BURNS CAN RESULT ON EXPOSED SKIN. FAILURE TO CHECK PRESSURE RELIEF VALVE OPERATION PERIODICALLY COULD RESULT IN PERSONAL INJURY AND/OR DAMAGE TO EQUIPMENT.

CAUTION: KEEP GREASE AWAY FROM ELECTRICAL PARTS LOCATED NEAR THE GEARS.

WARNING: TO AVOID INJURY, READ AND FOLLOW ALL PRECAUTIONS STATED ON THE LABEL OF THE WATER TREATMENT COMPOUND.

WARNING: USE OF ANY REPLACEMENT PARTS OTHER THAN THOSE SUPPLIED BY THE MANUFACTURER OR THEIR AUTHORIZED DISTRIBUTORS CAN CAUSE INJURY TO THE OPERATOR AND DAMAGE TO THE EQUIPMENT AND WILL VOID ALL WARRANTIES.

CAUTION: INSURE ELECTRICAL POWER IS REMOVED AND THE GAS IS TURNED OFF AT THE SHUTOFF VALVE PRIOR TO PERFORMING ANY MAINTENANCE ON THIS KETTLE.

WARNING: THIS KETTLE IS DESIGNED TO BE WATER RESISTANT. FAILURE TO FOLLOW PROPER MAINTENANCE PROCEDURES MAY VOID THE WARRANTY.

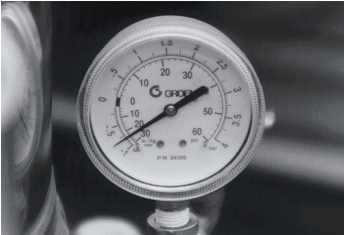

The pressure gauge should show a vacuum of -20 to -30 inches of mercury (Hg) vacuum or a range of -0.7 to -1.0 Bar when the kettle is cold.

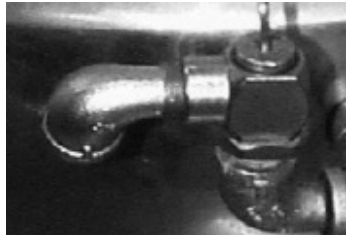

The open end of the pressure relief valve elbow must face downward.

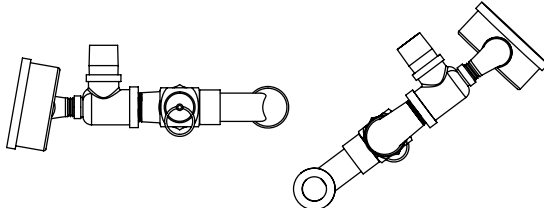

The pressure relief valve is located directly behind the pressure/vacuum gauge.

PERIODIC MAINTENANCE

NOTICE: Contact an authorized representative when repairs are required.

A Maintenance & Service Log is provided at the back of this manual. Each time maintenance is performed on your kettle, enter the date on which the work was done, what was done, and who did it. Keep this manual on file and available for operators to use. Periodic inspection will minimize equipment down time and increase the efficiency of operation. The following points should be checked:

JACKET VACUUM/REMOVING AIR FROM JACKET

When the kettle is cold, a positive pressure reading on the pressure/vacuum gauge or a reading near 0 psi (0 kPa, 0 bar) indicates that there is air in the jacket. Air in the jacket acts as an insulator, and slows kettle heating.

To remove air:

1. Start the unit. (Be sure there is water or product in the kettle when heating).
2. When the pressure/vacuum gauge reaches a positive pressure reading of 5 psi (35 kPa, 0.34 bar), release the trapped air and steam by pulling up the safety valve ring for about five seconds. Repeat this step three or four times. Then let the pull ring snap back into the closed position.
3. If there is little discharge (mostly air), and the pressure gauge drops back to 0 psi (0 kPa, 0 bar), allow the pressure to build back to 5 psi (35 kPa, 0.34 bar) and repeat the procedure.
4. Once steam has been vented from the jacket as described in b, above, remove

the hot water from the kettle and replace it with cold. This will condense steam in the kettle jacket, and the pressure gauge should show -20 to -30 inches of mercury (Hg) vacuum or a range of -0.7 to -1.0 Bar. If it does not, or if the vacuum is leaking down, contact an authorized service agency to correct the problem.

PRESSURE RELIEF VALVE

At least twice a month, test the pressure relief valve. Test the valve with the kettle operating at 15 PSI (105 kPa, 1.1 bars), by holding the test ring for at least five seconds. Then release the ring and permit the valve to snap shut. If the ring does not activate, if there is no discharge, or if the valve leaks, stop using the kettle immediately and contact a authorized service representative.

GREASE / LUBRICATION

1. Hand Tilt Models

At least twice a year, grease the two trunnion bearings. The bearings are located within the kettle support housing. Remove the access panels from the support housing with a screwdriver to gain access to the grease fittings. Use a lithium-based, multi-purpose grease. When the access panels are removed, the mounting bolts for the trunnion bearings and tilt switch can also be checked for tightness. When finished, reassemble access panels to support housing.

2. Crank Tilt Models

The gear housing has been fitted for proper lubrication of moving parts. Since the gears do not run in oil, periodic lubrication with grease is essential. Frequency of lubrication depends on operating conditions, but should occur at least once every six months. The use of a Number Two grade LGI lithium grease is recommended. Add grease through the Zerk fittings on the gear housing until grease flows out of the bearings around the trunnion shaft. Place a liberal amount of grease on the gear to cover the arc that is in contact with the worm gear.

JACKET FILLING AND WATER TREATMENT

The jacket was charged at the factory with the proper amount of treated water. You may need to restore this water, either because it was lost as venting steam or by draining. If you are replacing water lost as steam, use distilled water. If you are replacing treated water that ran out of the jacket, prepare more treated water as directed in "Water Treatment Procedure," below.

1. If you are replacing water lost as steam, use distilled water. Do not use tap water. If you are replacing treated water that was drained from the jacket, prepare more treated water as directed below.
2. Allow the kettle to cool completely. Remove the elbow and pressure relief with an open-end wrench or crescent wrench. Pour in the distilled or treated water. Using a funnel will help you in this process. Continue adding water until the water level rises to the center of the round sight glass.
3. Apply teflon tape in a clockwise pattern and reinstall the pressure relief.
4. Air that gets into the jacket during the filling operation must be removed, because it will make heating less efficient. Follow the procedure in Jacket Vacuum/Removing Air From Jacket above, to restore a negative pressure reading.

WATER TREATMENT PROCEDURE

1. Obtain water treatment compound and a pH test kit from your Groen Service Agent.
2. Fill a mixing container with the measured amount of water required. Use only distilled water.

Model	Kettle Capacity	Jacket Capacity
TDH-20 (C,A), TDHC-20 (C,A)	5 gal (20 qt), 19 liter	6 quart, 5.7 liter
TDH-24 (C,A), TDHC-24 (C,A)	6 gal (24 qt), 23 liter	6 quart, 5.7 liter
TDH-40 (C,A), TDHC-40 (C,A)	10 gal (40 qt), 38 liter	12 quart, 11.4 liter
TDH-48 (C,A), TDHC-48 (C,A)	12 gal (48 qt), 45 liter	12 quart, 11.4 liter

- Hang a strip of pH test paper on the rim of the container, with about 1 inch of the strip below the surface of the water.
- Measure the water treatment compound. One way to do this is to add the compound from a measuring cup.
- Stir the water continuously, while you slowly add treatment compound, until the water has a pH between 10.5 and 11.5. Judge the pH by frequently comparing the test strip color with the color chart provided in the test kit. Caution: Do not add excess amount of treatment compound. Excess amount could cause extensive corrosion.
- Record the exact amounts of water and treatment compound needed. These amounts may be used again, if the same water sources and compound are used. However, it is best to check the pH each time treated water is prepared.

SEQUENCE OF OPERATION

The following “action-reaction” outline is provided to help understand how the kettle works.

- When the power switch is turned on, it starts the spark igniter and opens the automatic valve for the pilot burner. The spark ignites a pilot flame, which heats the sensor. The sensor then sends a signal to turn off the spark. The flame thereafter acts as a standing pilot until the power is turned off.
- If the pilot flame is not sensed within 90 seconds after spark begins, a timer shuts down the entire operation. To attempt a second trial for ignition, turn off the power switch. Check the gas supply valves and wait five minutes before trying again by switching power on. If you cannot establish a pilot flame in four tries, close all valves, turn off the power, and contact an authorized Service Agency.
- When the operator sets a temperature on the controller, it causes the automatic valve to admit gas to the main burner, where it is ignited by the pilot flame. When the kettle reaches the set temperature, the relay switch opens. This stops the signal to the gas control valve and shuts off gas to the main burner. The pilot flame remains lit. When the kettle cools below the set temperature, the relay switch closes and starts another cycle. On and off cycling continues and maintains the kettle at the desired temperature. This action is indicated by the Heat indicator light.

The kettle has the following safety features in addition to the 90-second ignition timer:

- Low water cutoff relay that will shut off gas supplies to all burners until the jacket water level is corrected.
- Pressure switch, set to open at about 46 PSI (345 kPa, 3.17 bars) and to shut down the burners until jacket pressure is decreased.
- Pop safety valve, which will release steam if jacket pressure exceeds 50 PSI (345 kPa, 3.45 bars).
- Tilt switch, which shuts off all burners when the kettle is tilted.
- Gas pressure regulator built into the gas control valve.

REPLACEMENT PARTS

To order parts, contact your Authorized Service Agent. Supply the model designation, serial number, part description, part number, quantity, and when applicable, voltage and phase.

CONTACT US

If you have questions pertaining to the content in this manual, contact Groen at 888-994-7636.

TROUBLESHOOTING

This unit is designed to operate smoothly and efficiently if properly maintained. However, the following is a list of checks to make in the event of a problem. Wiring diagrams are found at the end of this manual. When in doubt, turn unit off and call for service at 888-994-7636. If an item on the check list is marked with (X), it means that the work should be done by an Authorized Service Agent.

SYMPTOM	WHO	WHAT TO CHECK X indicates items which must be performed by authorized technician.
Display not lit (Advanced & C2T only)	User	a. That power supply is on.
	Auth Service Rep Only	b. Fuses, accessible by removing caps on the side of the control box. c. For loose or broken wires. X d. Temperature controller functioning, by listening for a click when the switch opens or closes and verifying LEDs on back of board. X e. Contactor functioning. X
PROB in display (Advanced & C2T only)	Auth Service Rep Only	a. For loose or broken wires or damaged/failed RTD probe. X b. PCB board malfunction/failure
HI in display (Advanced & C2T only)	Auth Service Rep Only	a. For loose or broken wires or damaged/failed RTD probe. X b. PCB board malfunction/failure
	User	a. Gears for foreign materials, and lubrication.
Kettle is hard to tilt	Auth Service Rep Only	b. Gears for alignment. X c. Worm gears or broken gears. X
	User	a. Temperature Controller dial setting.
Kettle continues heating after it reaches the desired temperature	Auth Service Rep Only	b. Temperature Controller calibration and offset. X c. Temperature Controller operation. The Temperature Controller should click when the dial is rotated to settings above and below the temperature of the kettle. X
	User	a. Temperature Controller dial setting.
Kettle stops heating before it reaches the desired temperature	Auth Service Rep Only	b. Temperature Controller calibration and offset. X c. Temperature Controller operation. The Temperature Controller should click when the dial is rotated to settings above and below the temperature of the kettle. X
	User	a. For air in the jacket. See "Jacket Vacuum" in the Maintenance b. Temperature Controller dial setting.
Safety Valve pops open	Auth Service Rep Only	c. For defective Temperature Controller. The relay should click when the dial is rotated to settings above and below the temperature of the kettle. If defective, replace. X d. For defective safety valve. If the valve pops at pressures below 49 PSI, replace. X
	User	a. That the main gas supply valve is open. (handle is in line with gas pipe). b. Gas supply to the building. c. That the kettle body is not tilted.
Burners will not light	Auth Service Rep Only	d. Temperature Controller operation. The relay should click when the dial is rotated to settings above and below the temperature of the kettle. X e. That tilt limit switch is closed when body is not tilted. X
	User	a. AC voltage between terminals on secondary side of transformer. If it is not 24 Volt, replace the transformer. X b. That the high tension cable is firmly attached and in good condition. If cracked or brittle, replace. X c. Pilot electric ceramic for crack or break. X d. Pilot spark gap. Regap. X
System does not produce a spark	Auth Service Rep Only	a. That the pilot valve is securely connected to terminals. X b. For 24 VAC at terminals PV and PV/MV. If 24V is not present, replace the ignition control module. X c. That gas pressure is at least 3.5" W.C. (8.7818 ub). For gas at the pilot. If it is not flowing: (1) Check the pilot gas line for kinks and obstructions. X (2) Clean orifice, if necessary. X (3) Check magnetic operator for pilot valve on gas valve. Repair or replace as necessary. X d. That the pilot spark gap is located in the pilot gas stream. If not, adjust or replace the pilot burner. X e. For drafts. Shield the pilot burner, if necessary. X
Spark is present but the pilot will not light	Auth Service Rep Only	a. For 24 V between terminals MV and PV/MV while pilot is burning. If 24V is not present, replace the ignition control module. X b. That gas pressure is at least 3.5" W.C. (8.7818 ub). X c. Electrical connections of the main valve to terminals, to assure that they are securely attached. Check magnetic operator for main valve on gas valve. Repair or replace as necessary. X
Pilot lights, but main burner will not come on and spark does not stay on	Auth Service Rep Only	a. Check for bad burner ground. If necessary, repair with high temperature wire. X b. Pilot burner ceramic insulator for cracks. X c. That cable is not grounded out. If it is, correct the ground-out condition or replace cable. X d. For proper gas pressure. X e. Clean pilot assembly, or replace if necessary. X f. Tighten all mechanical and electrical connections. X g. If the pilot flame is weak, increase pilot orifice size. X h. Replace ignition control module. X
Pilot lights, but main burner will not come on, the spark stays on	Auth Service Rep Only	a. Check burner ground for bad wire or connection. Replace if necessary with high temperature wire. X b. Check for low gas supply pressure. If necessary, replace ignition control module. X
Main burner comes on but will not stay on	Auth Service Rep Only	a. Check burner ground for bad wire or connection. Replace if necessary with high temperature wire. X b. Check for low gas supply pressure. If necessary, replace ignition control module. X

Key	Qty	Description	Part No.
1	1	KETTLE BODY ASSY	CONSULT FACTORY
2	1	GLASS, SITE ROUND	108554
3	1	GAS VALVE, CE MARK, G20	160776
3A	1	GAS VALVE, CE MARK, G31	160796
4	1	1/2" NPT TO 1/2" BSPT ADAPTER	116392
5	1	2" ALUMINUM KNOB	175095
6	1	VALVE, 1/4" SWING, CHECK	096915
7	1	GAUGE	084208
8	1	POWER SWITCH	177910
9	1	CONTROL, CLASSIC	174843
10	1	VALVE PRESSURE RELIEF	097005
11	2	LIGHT, AMBER	116384
12	1	ROTARY SHAFT SEAL	101145
13	1	SWITCH, PRESSURE (NOT SHOWN)	096963
14	1	SHAFT, HANDLE	018963
15	1	RING, 1/2"	012692
16	1	BALL, RED	012691
17	1	ELECTRODE, WATER LEVEL (NOT SHOWN)	074623

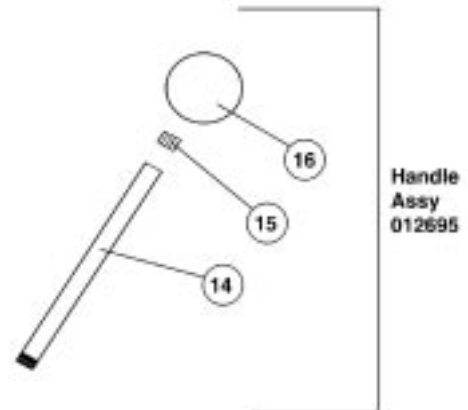
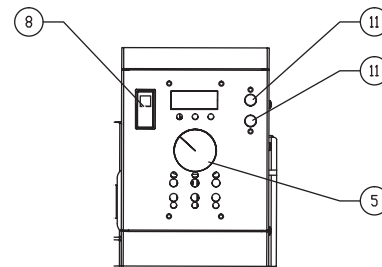
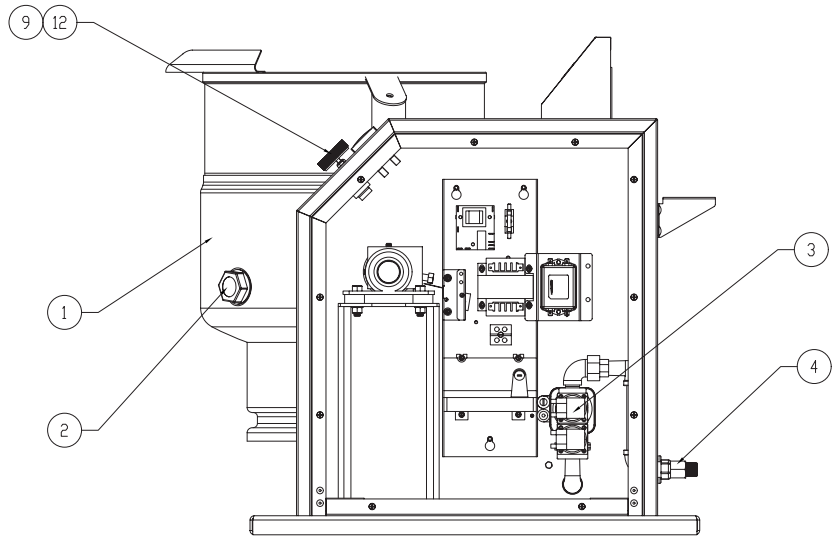

Key	Qty	Description	Part No.
1	1	KETTLE BODY ASSY	CONSULT FACTORY
2	1	GLASS, SITE ROUND	108554
3	1	GAS VALVE, CE MARK, G20	160776
3A	1	GAS VALVE, CE MARK, G31	160796
4	1	1/2" NPT TO 1/2" BSPT ADAPTER	116392
5	1	2" ALUMINUM KNOB	174829
6	1	VALVE, 1/4" SWING, CHECK	096915
7	1	GAUGE	084208
8	1	POWER SWITCH	177910
9A	1	CONTROL, ADVANCED	174837
10	1	VALVE PRESSURE RELIEF	097005
11	2	LIGHT, AMBER	116384
12	1	ROTARY SHAFT SEAL	101145
13	1	SWITCH, PRESSURE (NOT SHOWN)	096963
14	1	SHAFT, HANDLE	018963
15	1	RING, 1/2"	012692
16	1	BALL, RED	012691
17	1	ELECTRODE, WATER LEVEL (NOT SHOWN)	074623

x- Item not depicted/called out in drawing or photograph

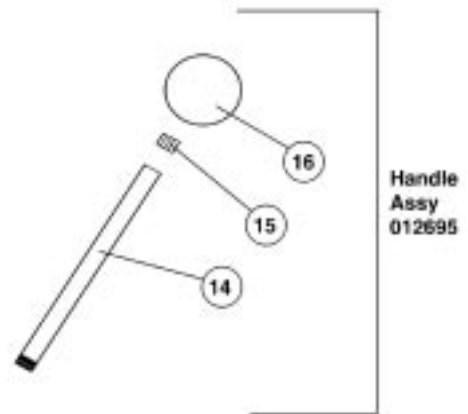
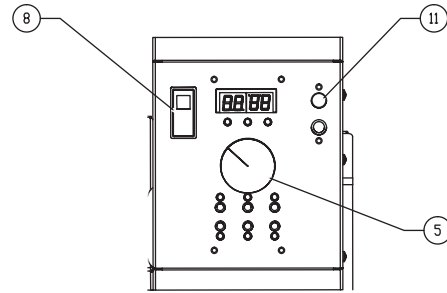
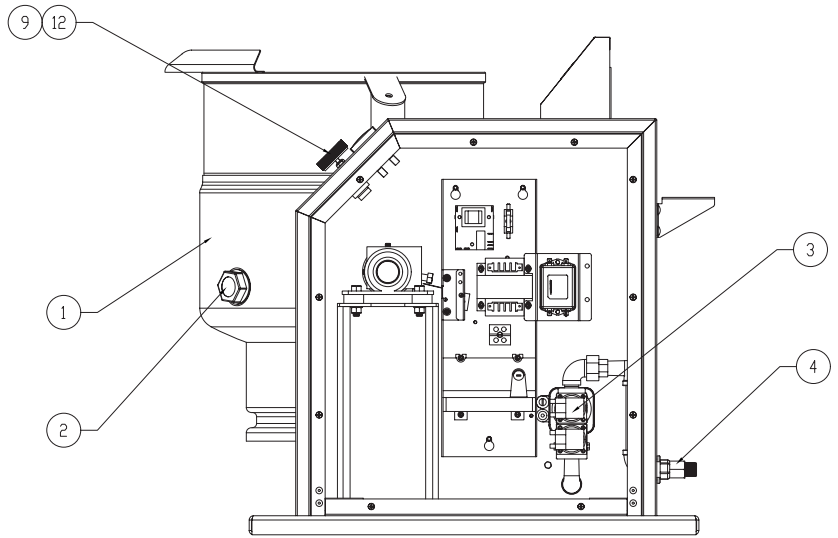

Parts List

Key	Description	Part No.
1	NIPPLE, 3/8" NPT X 2"	005679
2	UNION, 3/8" NPT	005686
3	MANIFOLD, 5- AND 6-GALLON	137757
3	MANIFOLD, 10- AND 12-GALLON	137056
4	PILOT	097024
5	TUBE, PILOT	135487
6	PILOT ORIFICE SPUD NATURAL GAS	098648
6	PILOT ORIFICE SPUD PROPANE GAS	098647
7	FITTING, COMPRESSION 90 (NOT SHOWN)	004584
8	ORIFICE SEE TABLE BELOW	-

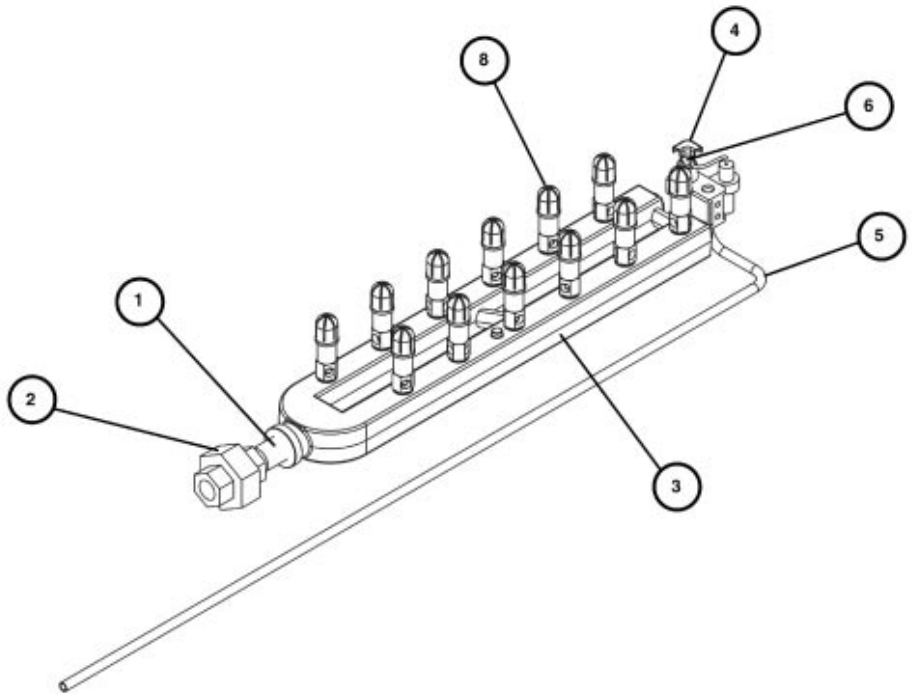

Model	# of Orifices	Natural Gas	Propane Gas	Altitude
THD-20 TDHC-20	8	137758	137756	0 - 2000 ft.
TDH-24 TDHC-24	8	137758	137756	0 - 2000 ft.
TDH-40 TDHC-40	12	135543	137756	0 - 2000 ft.
TDH-48 TDHC-48	12	135543	137756	0 - 2000 ft.

Key	Description	Part No.
1	WELDMENT, BASE	137060
2	WELDMENT, PEDESTAL	124735
3	WELDMENT, BASE SUPPORT	124729
4	WASHER LOCK 1/2" S.S.	005657
5	SCREW, HEX HD 1/2-13 X 1 1/4"	005623
6	NUT HEXAGON 1/2" - 13	005603
7	SCREW TRUSS HD 1/4-20 X 1/2 S.S.	012700
8	ASM, CABINET WELD	174762
9	SHROUD BURNER WELD ASM	135526
10	SHIELD, PILOT	135524
11	BURNER BRACKET WELD ASM.	135527
12	BRACKET, BURNER SUPPORT	137353
13	SCREW, TRUSS HD #8-32 X 3/8"	005764
14	SCREW, HED HD 1/4"-20 X 1/2"	005608
15	WASHER LOCK 1/4"	005655
16	SCREW HEX HD CAP 1/4"-20 X 1-1/2"	005469
17	NUT HEXAGON KEPS 1/4" - 20	012940
18	PLATE SHROUD WELD ASM	137680
19	SEAL TRUNNION	137005
20	PLATE, SHROUD WELD ASM (5/6-QT)	137700
20	PLATE, SHROUD WELD ASM (10/12-QT)	137380
21	GASKET, 3/8" THK X 1/2" WIDE, 6" CENTER	137588
22	E-RING, 1.875" DIA	138357
23	FAUCET BRACKET	137738
24	GROMMET 7/8" ID X 1-5/8" OD	007400
25	COVER, CABINET	175309
26	SCREW, 10-32 X 1/2" COMBI HEAD	137766
27	CONNECTOR STRAIGHT 3/8" SEALTITE	001669
28	HARNESS ASM	137006
29	HARNESS ASM HIGH VOLTAGE	137546
30	STRAP CABLE TY-RAP	011093
31	SEALANT RTV #732, GREY	001711

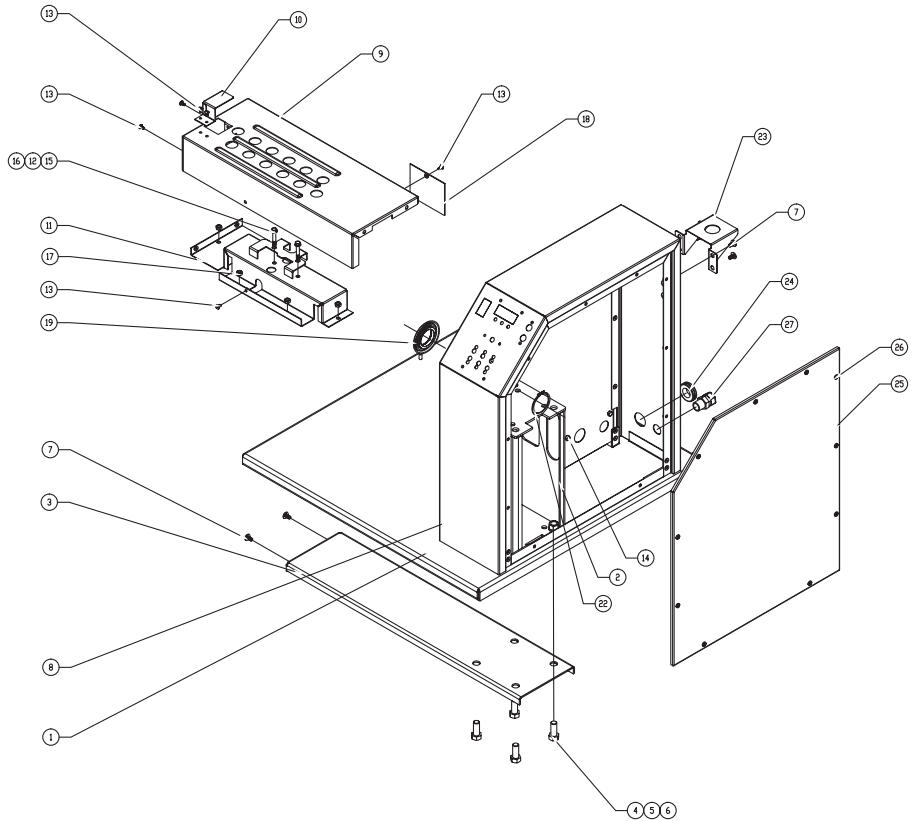

Key	Description	Part No.
1	WELDMENT, BASE	137060
2	WELDMENT, PEDESTAL	174792
3	WELDMENT, BASE SUPPORT	124729
4	WASHER LOCK 1/2" S.S.	005657
5	SCREW, HEX HD 1/2-13 X 1 1/4"	005623
6	NUT HEXAGON 1/2" - 13	005603
7	SCREW TRUSS HD 1/4-20 X 1/2 S.S.	012700
8	ASM, CABINET WELD	174799
9	SHROUD BURNER WELD ASM	135526
10	SHIELD, PILOT	135524
11	BURNER BRACKET WELD ASM.	135527
12	BRACKET, BURNER SUPPORT	137353
13	SCREW, TRUSS HD #8-32 X 3/8"	005764
14	SCREW, HED HD 1/4"-20 X 1/2"	005608
15	WASHER LOCK 1/4"	005655
16	SCREW HEX HD CAP 1/4"-20 X 1-1/2"	005649
17	NUT HEXAGON KEPS 1/4" - 20	012940
18	PLATE SHROUD WELD ASM	137680
19	SEAL TRUNNION	137005
20	PLATE, SHROUD WELD ASM (5/6-QT)	137700
20	PLATE, SHROUD WELD ASM (10/12-QT)	137380
21	GASKET, 3/8" THK X 1/2" WIDE, 6" CENTER	137588
22	E-RING, 1.875" DIA	138357
23	FAUCET BRACKET	137738
24	GROMMET 7/8" ID X 1-5/8" OD	007400
25	COVER, CABINET	175309
26	SCREW, 10-32 X 1/2" COMBI HEAD	137766
27	CONNECTOR STRAIGHT 3/8" SEALTITE	001669
28	HARNESS ASM	137006
29	HARNESS ASM HIGH VOLTAGE	137546
30	STRAP CABLE TY-RAP	011093
31	SEALANT RTV #732, GREY	001711
32	O-RING #018	138359
33	E-RING, 1.00"	138356
34	COLLAR, SHAFT SEAL, .750"	138354
35	SEAL, SHAFT 1.00"	136088

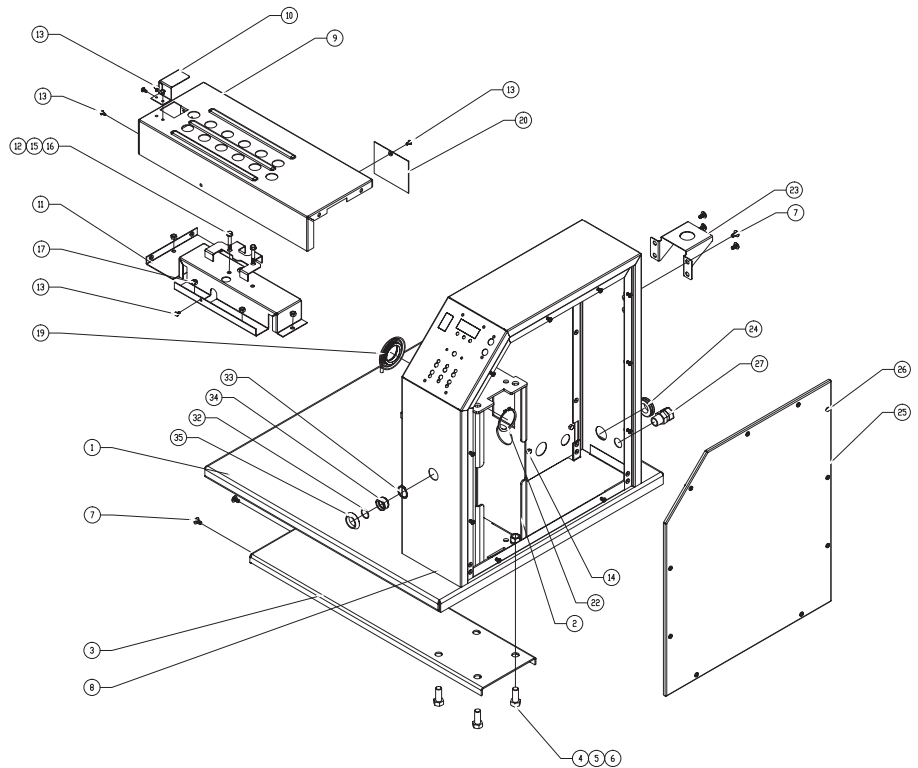

Key	Description	Part No.
1	SPACER, PILLOW BLOCK	137692
2	PILLOW BLOCK	002989
3	STOP, MANUAL TILT	137697
4	KEY, 1/4 SQ X .5" LG	137746
5	COLLAR SET 1-1/2" ID X 2-1/4" OD X 3/4" THK	003118
6	SCREW HEX HD CAP 3/8"-16 X 1-1/2"	005615
7	WASHER FLAT 3/8"	005830
8	NUT HEX 3/8"-16	005619
9	NUT HEX 5/16"-18	005602
10	SCREW SET SOCKET	086617
11	SCREW SET SOCKET	003400
12	SCREW HEX HD CAP 5/16"-18 X 1"	005613

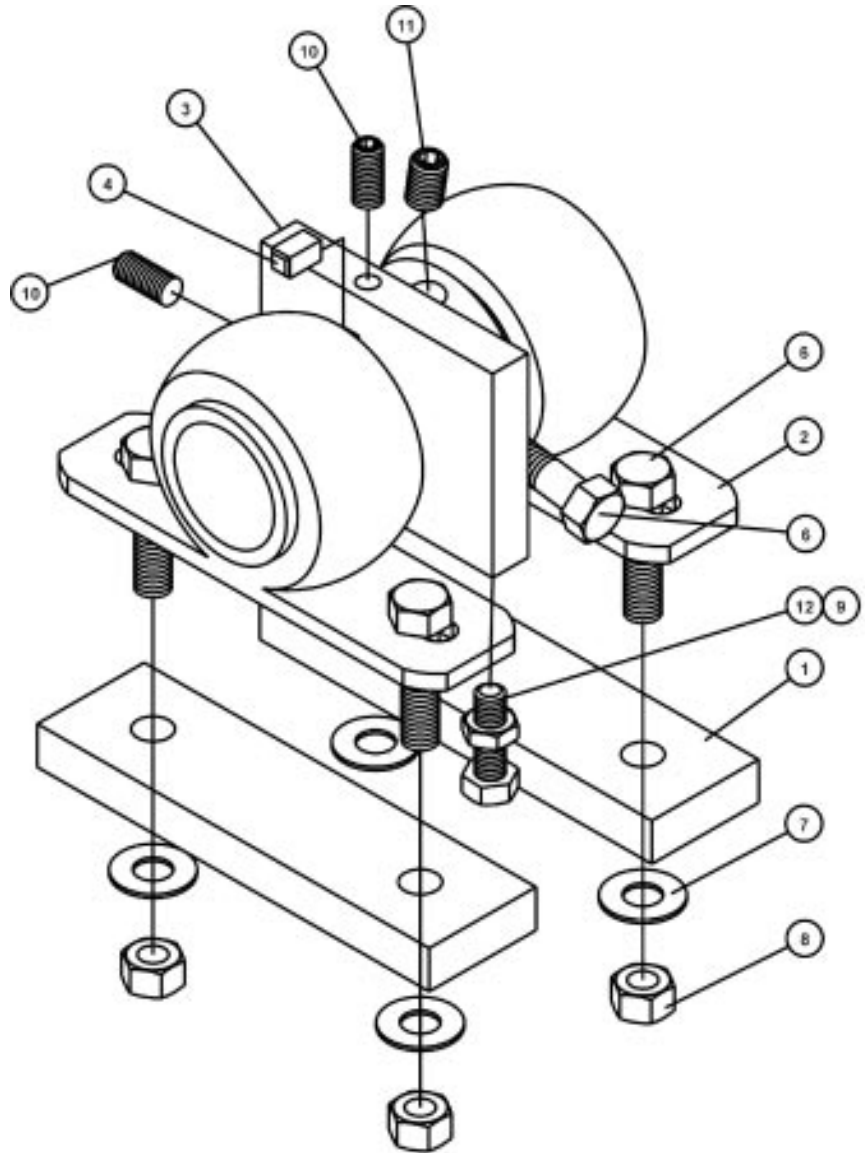

Key	Description	Part No.
1	ASSEMBLY, GEAR CARRIER	124741
2	SHAFT, WORM	122374
3	GEAR, WORM	128001
4	ASSEMBLY, GEAR SECTOR	128028
5	ASSEMBLY, BEARING BLOCK	128021
6	KEY, 1/4 SQ X 1" LG.	122371
7	RETAINING RING 1.500	124764
8	ASSEMBLY, HANDWHEEL	124719
9	PIN, ROLL 1/4" X 1.63 LG.	128036
10	WASHER, FLAT 3/8"	005830
11	WASHER, LOCK 3/8"	005618
12	SCREW, 3/8-16 X 1" HEX HD	005612
13	PIN, ROLL 1/4" X 1.25" LG.	012614

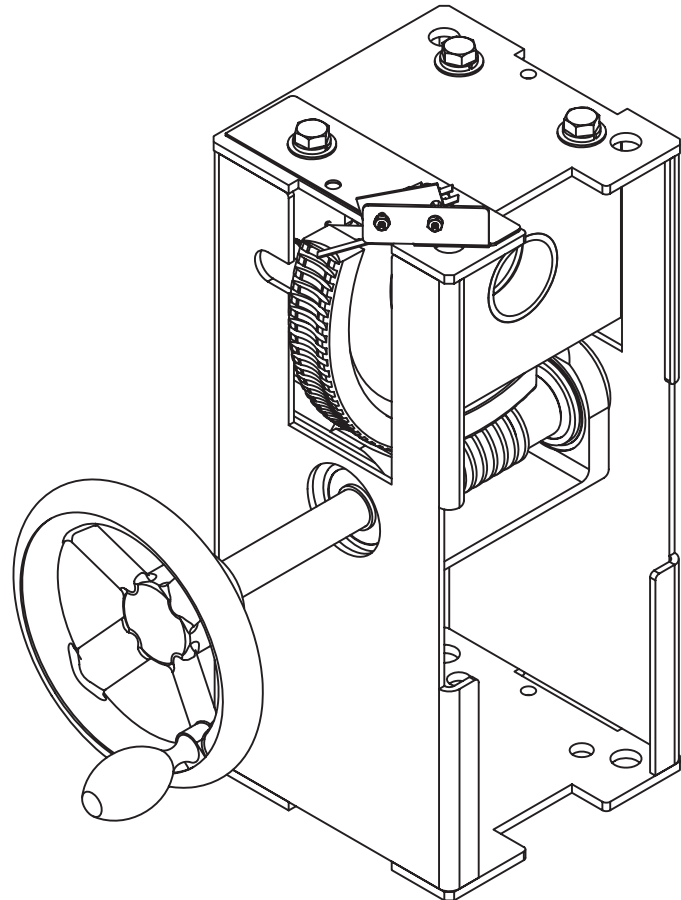
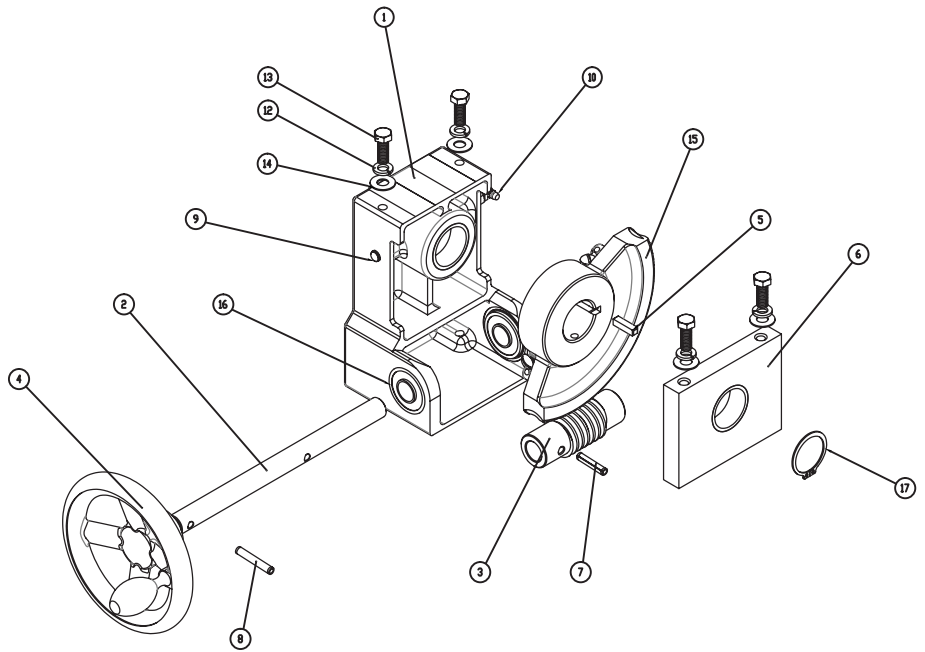

Parts List

Key	Qty	Description	Part No.
1	1	PRESSURE SWITCH	096963
2	1	RTD PROBE	175429
3	1	WATER LEVEL ELECTRODE	015589
4	1	BRACKET	137736
5	1	COVER (NOT SHOWN)	003141
6	1	GASKET, BOTTOM COVER	137969
7	1	SCREW, 1/4-20 X 1 1/2	012597
8	1	GASKET, BOTTOM COVER SCREW	137968

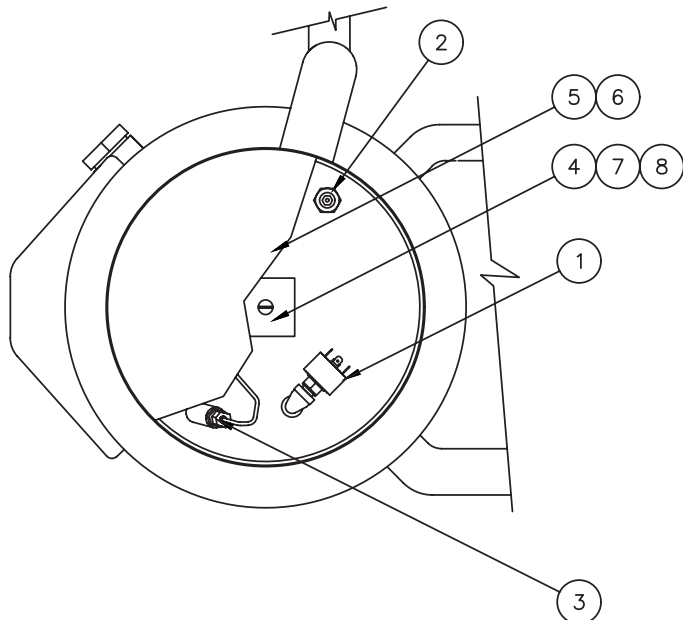

Key	Description	Part No.
1	GAUGE, COMPOUND PRESSURE W/ DUAL	084208
2	VALVE, PRESSURE RELIEF 50 PSI	097005
3	ASSY, WATER FILL SUB	137438
4	ELBOW 90 DEG STREET 1/2 NPT CHROME	010108

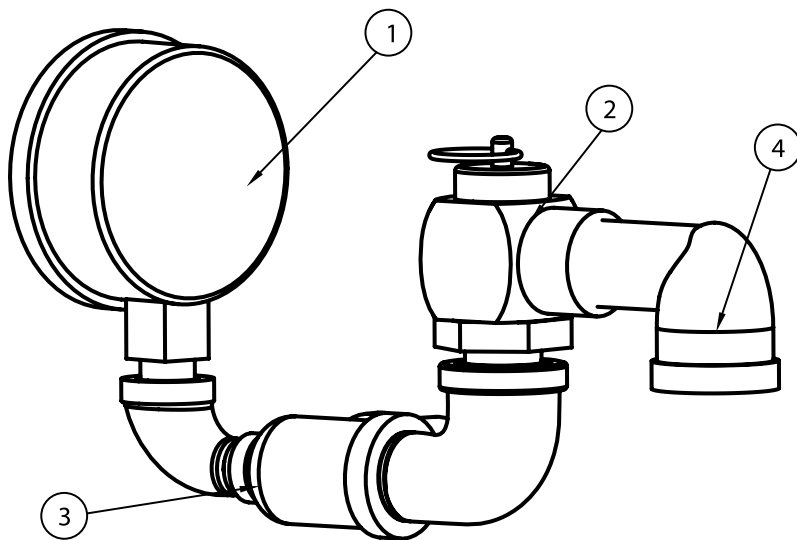
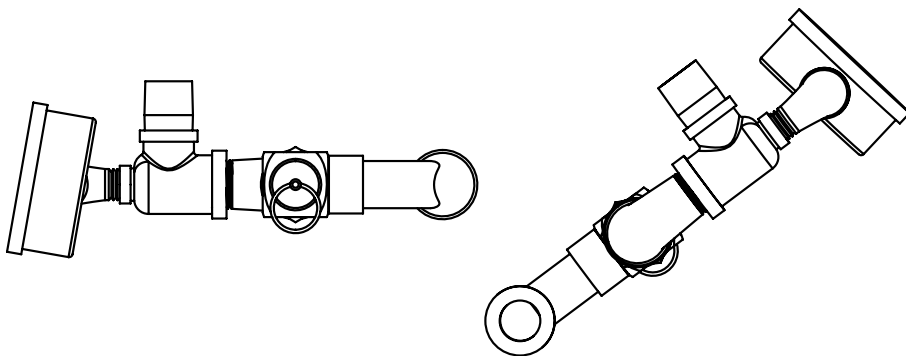

Key	Qty	Description	Part No.
1	1	ELEC. MOUNTING BRACKET	140420
2	1	CONTROL, WATER LEVEL, 24V	122192
3	1	MICRO SWITCH	002982
4	1	TERMINAL BLOCK, TWO POLE	003887
5	1	IGNITION MODULE	154059
6	1	FUSE, HOLDER, TYPE 3 AG	077854
7	1	FUSE, THREE AMP TYPE 3 AG	077853
8	1	SCREW, 6-32 X 3/8 LG (FOR #6)	009697
9	3	P.C. BOARD MOUNTING POST	099901
10	5	SCREW, 8 X 3/8 LG, HEX SLOT (FOR #5 AND #17)	069789
11	1	SCREW, #8-32 X 1-1/4 RND HEAD (FOR #4)	005056
12	2	SCREW, ROUND HEAD 4-40 X 3/4 LG. (FOR #3)	003122
13	1	BARRIER INSULATION (FOR #3)	003490
14	2	WASHER SHAKEPROOF LOCK, #6 (FOR #3)	005715
15	2	NUT, HEX 4-40 (FOR #3)	003121
16	1	TRANSFORMER, CE, 208/230/460 TO 24V	148899
17	1	LUG, GROUND	129714
18	1	BRACKET, EMI FILTER	177861
19	1	EMI FILTER	177768

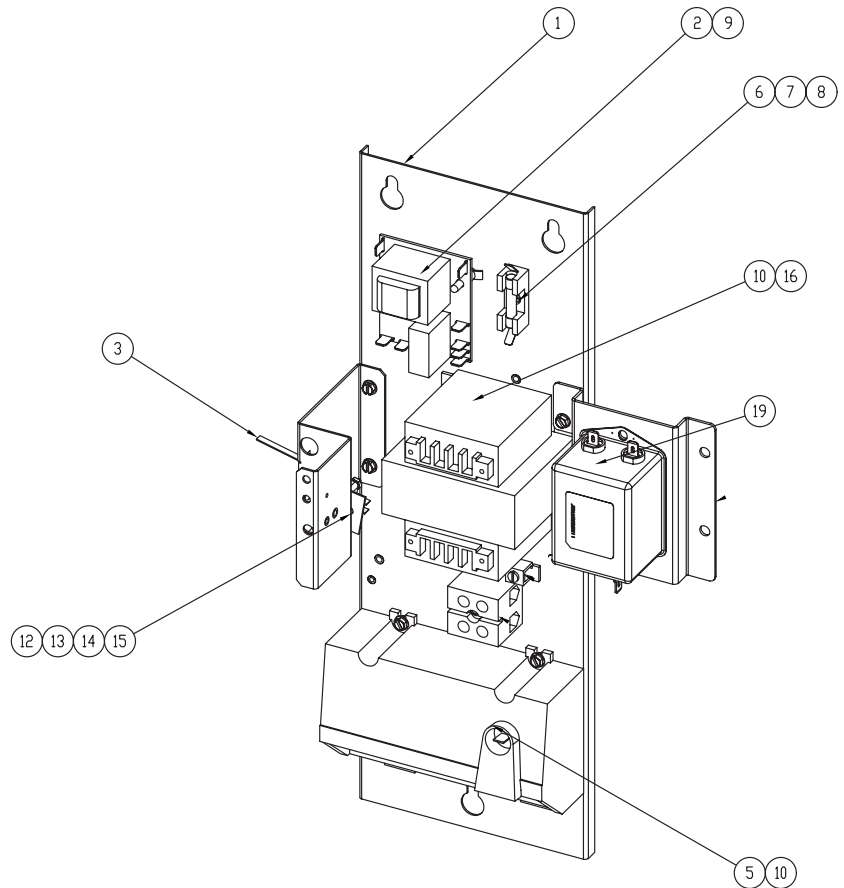

Key	Qty	Description	Part No.
1	1	ELEC. MOUNTING BRACKET	175323
2	1	CONTROL, WATER LEVEL, 24V	122192
3	1	TERMINAL BLOCK, TWO POLE	003887
4	1	IGNITION MODULE	154059
5	1	FUSE, HOLDER, TYPE 3 AG	077854
6	1	FUSE, THREE AMP TYPE 3 AG	077853
7	1	SCREW, 6-32 X 3/8 LG (FOR #6)	009697
8	3	P.C. BOARD MOUNTING POST	099901
9	5	SCREW, 8 X 3/8 LG, HEX SLOT (FOR #5 AND #17)	069789
10	1	SCREW, #8-32 X 1-1/4 RND HEAD (FOR #4)	005056
12	1	TRANSFORMER, CE, 208/230/460 TO 24V	148899
13	1	LUG, GROUND	129714
14	1	BRACKET, EMI FILTER	177861
15	1	EMI FILTER	177768
x	1	SCREW, ROUND HEAD 4-40 X 3/4 LG. (FOR #3)	003122
x	1	BARRIER INSULATION (FOR #3)	003490
x	1	WASHER SHAKEPROOF LOCK, #6 (FOR #3)	005715
x	1	NUT, HEX 4-40 (FOR #3)	003121

x- Item not depicted/called out in drawing or photograph

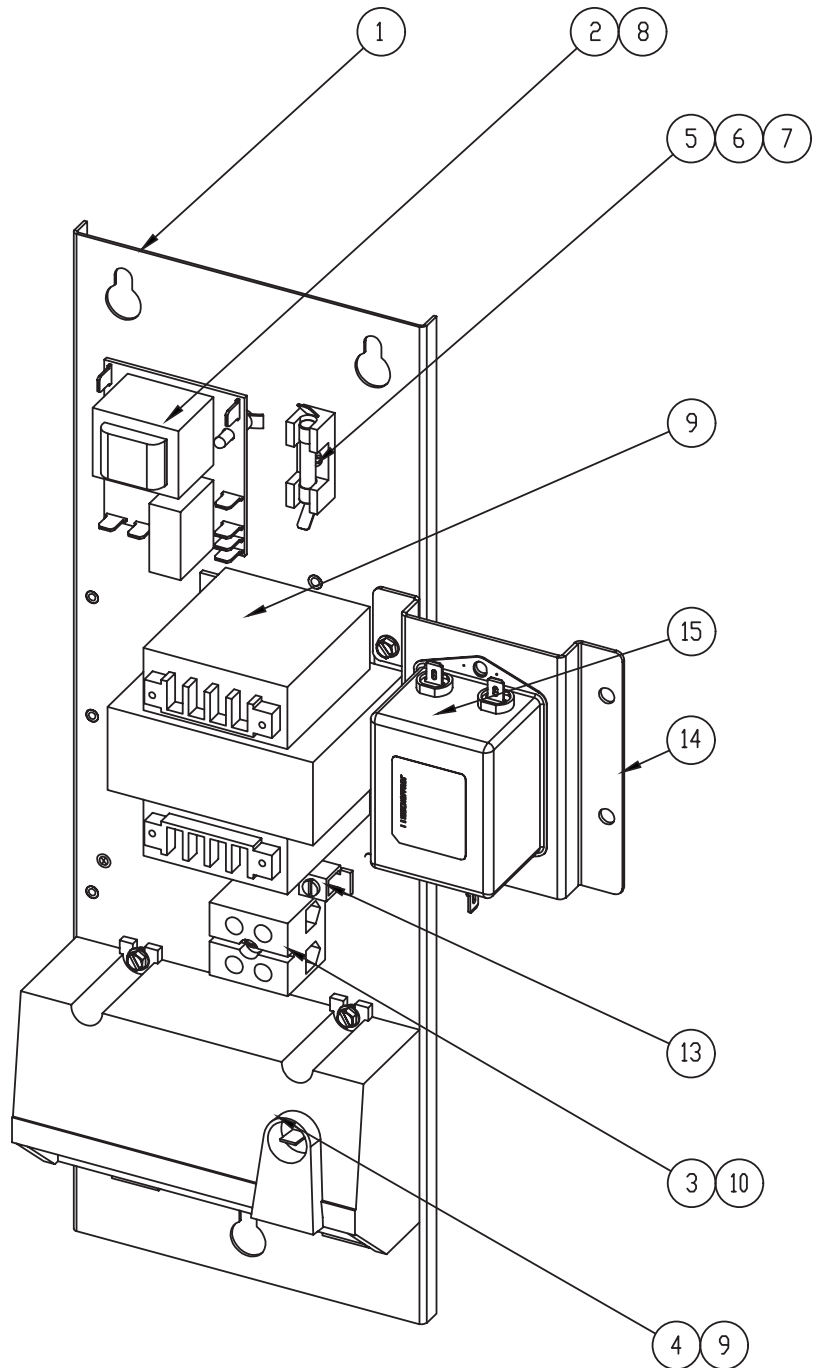

Wiring Diagram

